

| | | |
|--|---|---|
| Subject code : CE 2401 |  VSA Educational and Charitable Trust's Group of Institutions, Salem – 636 010 Department of Civil Engineering | Chapter |
| Name of the subject : DESIGN OF REINFORCED CONCRETE & BRICK MASONRY STRUCTURES | | Reference details : |
| Date of deliverance : | | Design of RC Elements, Mr. N . krishnaraju |

Unit II – water tank

Underground rectangular tanks – Domes – Overhead circular and rectangular tanks – Design of staging and foundations-Design as per BIS Codal Provisions.

Aim:

As per the IS Code requires underground water tank, dome & over head circular and rectangular tank with staging and foundation to be designed to ensure stability and satisfies the BIS codal provisions.

WATER TANKS

In general there are three kinds of water tanks-tanks resting on ground, underground tanks and elevated tanks.

The tanks resting on ground like clear water reservoirs, settling tanks, aeration tanks etc. are supported on the ground directly. The walls of these tanks are subjected to pressure and the base is subjected to weight of water and pressure of soil. The tanks may be covered on top.

The tanks like purification tanks, Imhoff tanks, septic tanks, and gas holders are built underground. The walls of these tanks are subjected to water pressure from inside and the earth pressure from outside. The base is subjected to weight of water and soil pressure. These tanks may be covered at the top.

Elevated tanks are supported on staging which may consist of masonry walls, R.C.C. tower or R.C.C. columns braced together. The walls are subjected to water pressure. The base has to carry the load of water and tank load. The staging has to carry load of water and tank. The staging is also designed for wind forces.

From design point of view the tanks may be classified as per their shape-rectangular tanks, circular tanks, intze type tanks. Spherical tanks conical bottom tanks and suspended bottom tanks.

Design requirement of concrete

In water retaining structures a dense impermeable concrete is required therefore, proportion of fine and course aggregates to cement should be such as to give high quality concrete.

Concrete mix weaker than M200 is not used. The minimum quantity of cement in the concrete mix shall be not less than 300 kg/m³.

The design of the concrete mix shall be such that the resultant concrete is sufficiently impervious. Efficient compaction preferably by vibration is essential. The permeability of the thoroughly compacted concrete is dependent on water cement ratio. Increase in water cement ratio increases permeability, while concrete with low water cement ratio is difficult to compact. Other causes of leakage in concrete are defects such as segregation and honey combing. All joints should be made water-tight as these are potential sources of leakage.

| | | |
|--|---|---|
| Subject code : CE 2401 |  VSA Educational and Charitable Trust's Group of Institutions, Salem – 636 010 Department of Civil Engineering | Chapter |
| Name of the subject : DESIGN OF REINFORCED CONCRETE & BRICK MASONRY STRUCTURES | | Reference details : |
| Date of deliverance : | | Design of RC Elements, Mr. N . krishnaraju |

Design of liquid retaining structures is different from ordinary R.C.C, structures as it requires that concrete should not crack and hence tensile stresses in concrete should be within permissible limits.

A reinforced concrete member of liquid retaining structures is designed on the usual principles ignoring tensile resistance of concrete in bending. Additionally it should be ensured that tensile stress on the liquid retaining face of the equivalent concrete section does not exceed the permissible tensile strength of concrete as given in table

1. For calculation purposes the cover is also taken into concrete area.

Cracking may be caused due to restraint to shrinkage, expansion and contraction of concrete due to temperature or shrinkage and swelling due to moisture effects. Such restraint may be caused by –

- (i) The interaction between reinforcement and concrete during shrinkage due to drying.
- (ii) The boundary conditions.
- (iii) The differential conditions prevailing through the large thickness of massive concrete.

Use of small size bars placed properly, leads to closer cracks but of smaller width. The risk of cracking due to temperature and shrinkage effects may be minimized by limiting the changes in moisture content and temperature to which the structure as a whole is subjected. The risk of cracking can also be minimized by reducing the restraint on the free expansion of the structure with long walls or slab founded at or below ground level, restraint can be minimized by the provision of a sliding layer. This can be provided by founding the structure on a flat layer of concrete with interposition of some material to break the bond and facilitate movement.

In case length of structure is large it should be subdivided into suitable lengths separated by movement joints, specially where sections are changed the movement joints should be provided.

Where structures have to store hot liquids, stresses caused by difference in temperature between inside and outside of the reservoir should be taken into account.

The coefficient of expansion due to temperature change may be taken as $11 \times 10^{-6}/^{\circ}\text{C}$ and coefficient of shrinkage may be taken as 450×10^{-6} for initial shrinkage and 200×10^{-6} for drying shrinkage.

3. Joints in Liquid Retaining Structures. Joints are classified as given below.

(a) **Movement Joints.** There are three types of movement joints.

(i) **Contraction Joint.** It is a movement joint with deliberate discontinuity without initial gap between the concrete on either side of the joint. The purpose of this joint is to accommodate contraction of the concrete. The joint is shown in Fig. 1(a).

| | | |
|--|---|---|
| Subject code : CE 2401 |  VSA Educational and Charitable Trust's Group of Institutions, Salem – 636 010 Department of Civil Engineering | Chapter |
| Name of the subject : DESIGN OF REINFORCED CONCRETE & BRICK MASONRY STRUCTURES | | Reference details : |
| Date of deliverance : | | Design of RC Elements, Mr. N . krishnaraju |

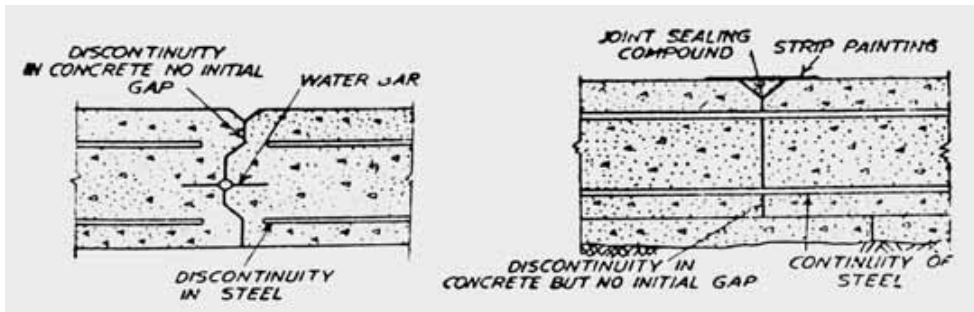

(a)

(b)

Fig 1.

A contraction joint may be either complete contraction joint or partial contraction joint. A complete contraction joint is one in which both steel and concrete are interrupted and a partial contraction joint is one in which only the concrete is interrupted, the reinforcing steel running through as shown in Fig. 1(b).

(ii) **Expansion Joint.** It is a joint with complete discontinuity in both reinforcing steel and concrete and it is to accommodate either expansion or contraction of the structure. A typical expansion joint is shown in Fig. 2.

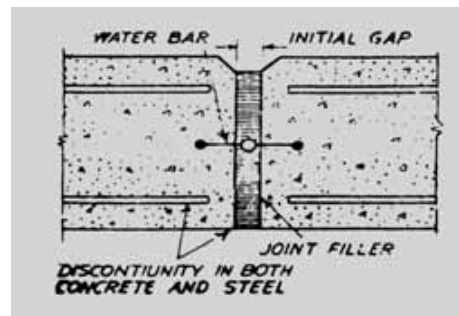



Fig. 2

This type of joint requires the provision of an initial gap between the adjoining parts of a structure which by closing or opening accommodates the expansion or contraction of the structure.

(iii) **Sliding Joint.** It is a joint with complete discontinuity in both reinforcement and concrete and with special provision to facilitate movement in plane of the joint. A typical joint is shown in Fig. 3. This type of joint is provided between wall and floor in some cylindrical tank designs.

(b) **Construction Joint.** This type of joint is provided for convenience in construction. Arrangement is made to achieve subsequent continuity without relative movement. One application

| | | |
|--|---|---|
| Subject code : CE 2401 |  VSA Educational and Charitable Trust's Group of Institutions, Salem – 636 010 Department of Civil Engineering | Chapter |
| Name of the subject : DESIGN OF REINFORCED CONCRETE & BRICK MASONRY STRUCTURES | | Reference details : |
| Date of deliverance : | | Design of RC Elements, Mr. N . krishnaraju |

of these joints is between successive lifts in a reservoir wall. A typical joint is shown in Fig. 4.

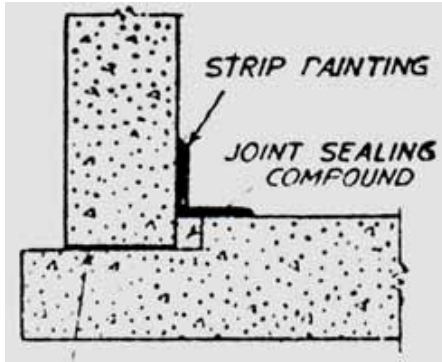

PREPARED SLIDING SURFACE
OR RUBBER PAO

Fig.3

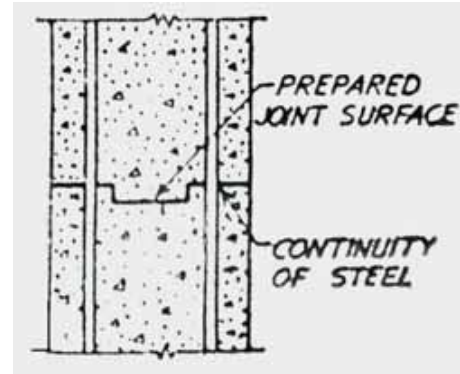

Fig.4

The number of joints should be as small as possible and these joints should be kept from possibility of percolation of water.

(c) **Temporary Open Joints.** A gap is sometimes left temporarily between the concrete of adjoining parts of a structure which

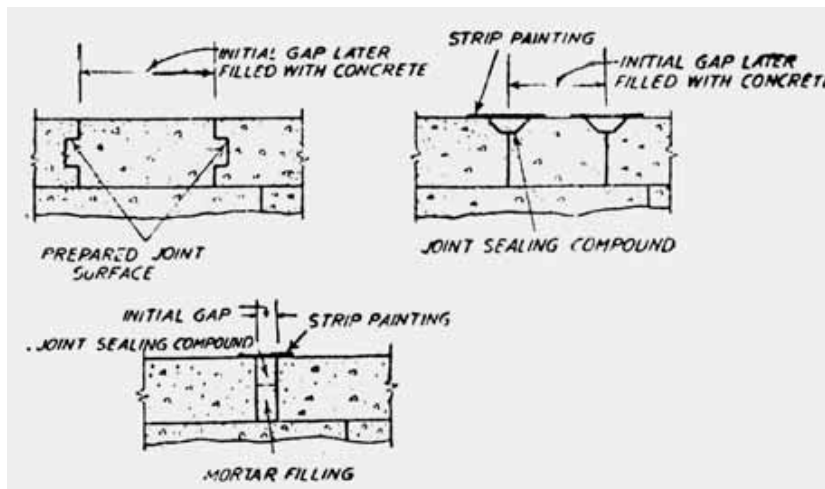



Fig. 5 Temporary open joints

after a suitable interval and before the structure is put to use, is filled with mortar or concrete completely as in Fig. 5(a) or as shown in Fig. 5 (b) and (c) with suitable jointing materials. In the first case width of the gap should be sufficient to allow the sides to be prepared before filling.

| | | |
|--|---|---|
| Subject code : CE 2401 |  VSA Educational and Charitable Trust's Group of Institutions, Salem – 636 010 Department of Civil Engineering | Chapter |
| Name of the subject : DESIGN OF REINFORCED CONCRETE & BRICK MASONRY STRUCTURES | | Reference details : |
| Date of deliverance : | | Design of RC Elements, Mr. N . krishnaraju |

Spacing of Joints. Unless alternative effective means are taken to avoid cracks by allowing for the additional stresses that may be induced by temperature or shrinkage changes or by unequal settlement, movement joints should be provided at the following spacings:-

(a) In reinforced concrete floors, movement joints should be spaced at not more than 7.5 m apart in two directions at right angles. The wall and floor joints should be in line except where sliding joints occur at the base of the wall in which correspondence is not so important.

(b) For floors with only nominal percentage of reinforcement (smaller than the minimum specified) the concrete floor should be cast in panels with sides not more than 4.5 m. (c) In concrete walls, the movement joints should normally be placed at a maximum spacing of 7.5 m. in reinforced walls and 6m. in unreinforced walls. The maximum length desirable between vertical movement joints will depend upon the tensile strength of the walls, and may be increased by suitable reinforcement. When a sliding layer is placed at the foundation of a wall, the length of the wall that can be kept free of cracks depends on the capacity of wall section to resist the friction induced at the plane of sliding. Approximately the wall has to stand the effect of a force at the place of sliding equal to weight of half the length

of wall multiplied by the co-efficient of friction.

(d) Amongst the movement joints in floors and walls as mentioned above expansion joints should normally be provided at a spacing of not more than 30 m. between successive expansion joints or between the end of the structure and the next expansion joint; all other joints being of the construction type.

(e) When, however, the temperature changes to be accommodated are abnormal or occur more frequently than usual as in the case of storage of warm liquids or in uninsulated roof slabs, a smaller spacing than 30 m should be adopted, that is greater proportion of movement joints should be of the expansion type). When the range of temperature is small, for example, in certain covered structures, or where restraint is small, for example, in certain elevated structures none of the movement joints provided in small structures up to 45m. length need be of the expansion type. Where sliding joints are provided between the walls and either the floor or roof, the provision of movement joints in each element can be considered independently.

4. General Design for Requirements (I.S.I)

1. **Plain Concrete Structures.** Plain concrete member of reinforced concrete liquid retaining structures may be designed against structural failure by allowing tension in plain concrete as per the permissible limits for tension in bending. This will automatically take care of failure due to cracking. However, nominal reinforcement shall be provided, for plain concrete structural members.

| | | |
|--|---|---|
| Subject code : CE 2401 |  VSA Educational and Charitable Trust's Group of Institutions, Salem – 636 010 Department of Civil Engineering | Chapter |
| Name of the subject : DESIGN OF REINFORCED CONCRETE & BRICK MASONRY STRUCTURES | | Reference details : |
| Date of deliverance : | | Design of RC Elements, Mr. N . krishnaraju |

2. Permissible Stresses in Concrete.

(a) **For resistance to cracking.** For calculations relating to the resistance of members to cracking, the permissible stresses in tension (direct and due to bending) and shear shall conform to the values specified in Table 1. The permissible tensile stresses due to bending apply to the face of the member in contact with the liquid. In members less than 225 mm. thick and in contact with liquid on one side these permissible stresses in bending apply also to the face remote from the liquid.

(b) **For strength calculations.** In strength calculations the permissible concrete stresses shall be in accordance with Table 1. Where the calculated shear stress in concrete alone exceeds the permissible value, reinforcement acting in conjunction with diagonal compression in the concrete shall be provided to take the whole of the shear.

Table 1
Permissible concrete stresses in calculations relating to resistance to cracking

| Grade of concrete | Permissible stress in kg/cm ² | | Shear (= Q/bjd) |
|-------------------|--|----------------|---------------------|
| | Tension | | |
| | Direct | Due to Bending | |
| M 150 | 11 | 15 | 15 |
| M 200 | 12 | 17 | 17 |
| M 250 | 13 | 18 | 19 |
| M 300 | 15 | 20 | 22 |
| M 350 | 16 | 22 | 25 |
| M 400 | 17 | 24 | 27 |

3. Permissible Stresses in Steel

(a) **For resistance to cracking.** When steel and concrete are assumed to act together for checking the tensile stress in concrete for avoidance of crack, the tensile stress in steel will be limited by the requirement that the permissible tensile stress in the concrete is not exceeded so the tensile stress in steel shall be equal to the product of modular ratio of steel and concrete, and the corresponding allowable tensile stress in concrete.

(b) **For strength calculations.** In strength calculations the permissible stress shall be as follows:

- (i) Tensile stress in member in direct tension 1000 kg/cm²
- (ii) Tensile stress in member in bending on liquid retaining face of members or face away from liquid for members less than 225 mm thick. 1000 kg/cm²

| | | |
|--|---|---|
| Subject code : CE 2401 |  VSA Educational and Charitable Trust's Group of Institutions, Salem – 636 010 Department of Civil Engineering | Chapter |
| Name of the subject : DESIGN OF REINFORCED CONCRETE & BRICK MASONRY STRUCTURES | | Reference details : |
| Date of deliverance : | | Design of RC Elements, Mr. N . krishnaraju |

- | | | |
|-------|---|-------------------------|
| | On face away from liquid for members 225 mm. or more in thickness. | 1250 kg/cm ² |
| (iii) | Tensile stress in shear reinforcement, For members less than 225 mm thickness | 1000 kg/cm ² |
| | For members 225 mm or more in thickness | 1250 kg/m ² |
| (iv) | Compressive stress in columns subjected to direct load. | 1250 kg/cm ² |

Note 1. Stress limitations for liquid retaining faces shall also apply to:

- Other faces within 225 mm of the liquid retaining face.
- Outside or external faces of structures away from the liquid but placed in water logged soils upto the level of highest subsoil water level.

Note 2. The permissible stress of 1000 kg/cm² in (i), (ii) and (iii) may be increased to 1125 kg/cm² in case of deformed bars and in case of plain mild steel bars when the cross reinforcement is spot welded to the main reinforcement.

4. Stresses due to drying Shrinkage or Temperature Change.

- Stresses due to drying shrinkage or temperature change may be ignored provided that –
 - the permissible stresses specified above in (ii) and (iii) are not otherwise exceeded.
 - adequate precautions are taken to avoid cracking of concrete during the construction period and until the reservoir is put into use.
 - recommendation regarding joints given in article 8.3 and for suitable sliding layer beneath the reservoir are complied with, or the reservoir is to be used only for the storage of water or aqueous liquids at or near ambient temperature and the circumstances are such that the concrete will never dry out.
- Shrinkage stresses may however be required to be calculated in special cases, when a shrinkage co-efficient of 300×10^{-6} may be assumed.
- When the shrinkage stresses are allowed, the permissible stresses, tensile stresses to concrete (direct and bending) as given in Table 1. may be increased by 33 per cent.

5. Floors

(i) **Provision of movement joints.** Movement joints should be provided as discussed in article 3.

(ii) **Floors of tanks resting on ground.** If the tank is resting directly over ground, floor may be constructed of concrete with nominal percentage of reinforcement provided that it is certain that the ground will carry the load without appreciable subsidence in any part and that the concrete floor is cast in panels with sides not more than 4.5 m. with contraction or expansion joints between. In such cases a

| | | |
|--|---|---|
| Subject code : CE 2401 |  VSA Educational and Charitable Trust's Group of Institutions, Salem – 636 010 Department of Civil Engineering | Chapter |
| Name of the subject : DESIGN OF REINFORCED CONCRETE & BRICK MASONRY STRUCTURES | | Reference details : |
| Date of deliverance : | | Design of RC Elements, Mr. N . krishnaraju |

screed or concrete layer less than 75 mm thick shall first be placed on the ground and covered with a sliding layer of bitumen paper or other suitable material to destroy the bond between the screed and floor concrete.

In normal circumstances the screed layer shall be of grade not weaker than M 100, where injurious soils or aggressive water are expected, the screed layer shall be of grade not weaker than M 150 and if necessary a sulphate resisting or other special cement should be used.

(iii) Floor of tanks resting on supports

(a) If the tank is supported on walls or other similar supports the floor slab shall be designed as floor in buildings for bending moments due to water load and self weight.

(b) When the floor is rigidly connected to the walls (as is generally the case) the bending moments at the junction between the walls and floors shall be taken into account in the design of floor together with any direct forces transferred to the floor from the walls or from the floor to the wall due to suspension of the floor from the wall. If the walls are non-monolithic with the floor slab, such as in cases, where movement joints have been provided between the floor slabs and walls, the floor shall be designed (only for the vertical loads on the floor).

(c) In continuous T-beams and L-beams with ribs on the side remote from the liquid, the tension in concrete on the liquid side at the face of the supports shall not exceed the permissible stresses for controlling cracks in concrete. The width of the slab shall be determined in usual manner for calculation of the resistance to cracking of T-beam, L-beam sections at supports.

(d) The floor slab may be suitably tied to the walls by rods properly embedded in both the slab and the walls. In such cases no separate beam (curved or straight) is necessary under the wall, provided the wall of the tank itself is designed to act as a beam over the supports under it.

(e) Sometimes it may be economical to provide the floors of circular tanks, in the shape of dome. In such cases the dome shall be designed for the vertical loads of the liquid over it and the ratio of its rise to its diameter shall be so adjusted that the stresses in the dome are, as far as possible, wholly compressive. The dome shall be supported at its bottom on the ring beam which shall be designed for resultant circumferential tension in addition to vertical loads.

6. Walls

(i) Provision of Joints

(a) **Sliding joints at the base of the wall.** Where it is desired to allow the walls to expand or contract separately from the floor, or to prevent moments at the base of the wall owing to fixity to the floor, sliding joints may be employed.

(b) The spacing of vertical movement joints should be as discussed in article 8.3 while the majority of these joints may be of the partial or complete contraction type, sufficient joints of the expansion type should be provided to satisfy the requirements given in article

| | | |
|--|---|---|
| Subject code : CE 2401 |  VSA Educational and Charitable Trust's Group of Institutions, Salem – 636 010 Department of Civil Engineering | Chapter |
| Name of the subject : DESIGN OF REINFORCED CONCRETE & BRICK MASONRY STRUCTURES | | Reference details : |
| Date of deliverance : | | Design of RC Elements, Mr. N . krishnaraju |

(ii) Pressure on Walls.

(a) In liquid retaining structures with fixed or floating covers the gas pressure developed above liquid surface shall be added to the liquid pressure.

(b) When the wall of liquid retaining structure is built in ground, or has earth embanked against it, the effect of earth pressure shall be taken into account.

(iii) Walls or Tanks Rectangular or Polygonal in Plan.

While designing the walls of rectangular or polygonal concrete tanks, the following points should be borne in mind.

- a) In plane walls, the liquid pressure is resisted by both vertical and horizontal bending moments. An estimate should be made of the proportion of the pressure resisted by bending moments in the vertical and horizontal planes. The direct horizontal tension caused by the direct pull due to water pressure on the end walls, should be added to that resulting from horizontal bending moments. On liquid retaining faces, the tensile stresses due to the combination of direct horizontal tension and bending action shall satisfy the following condition

$$\frac{t'}{t} + \frac{\sigma'_{ct}}{\sigma_{ct}} \leq 1$$

where

- t' = calculated direct tensile stress in concrete.
 t = permissible direct tensile stress in concrete (Table 1)
 σ'_{ct} = calculated tensile stress due to bending in concrete.
 σ_{ct} = permissible tensile stress due to bending in concrete.

(d) At the vertical edges where the walls of a reservoir are rigidly joined, horizontal reinforcement and haunch bars should be provided to resist the horizontal bending moments even if the walls are designed to withstand the whole load as vertical beams or cantilever without lateral supports.

(c) In the case of rectangular or polygonal tanks, the side walls act as two-way slabs, whereby the wall is continued or restrained in the horizontal direction, fixed or hinged at the bottom and hinged or free at the top. The walls thus act as thin plates subjected triangular loading and with boundary conditions varying between full restraint and free edge. The analysis of moment and forces may be made on the basis of any recognized method.

(ii) Walls of Cylindrical Tanks. While designing walls of cylindrical tanks the following points should be borne in mind:

(a) Walls of cylindrical tanks are either cast monolithically with the base or are set in grooves and key ways (movement joints). In either case deformation of wall under influence of liquid pressure is restricted at and above the base. Consequently, only part of the triangular hydrostatic load will be carried by ring tension and part of the load at bottom will be supported by cantilever action.

(b) It is difficult to restrict rotation or settlement of the base slab and it is advisable to provide

| | | |
|--|---|---|
| Subject code : CE 2401 |  VSA Educational and Charitable Trust's Group of Institutions, Salem – 636 010 Department of Civil Engineering | Chapter |
| Name of the subject : DESIGN OF REINFORCED CONCRETE & BRICK MASONRY STRUCTURES | | Reference details : |
| Date of deliverance : | | Design of RC Elements, Mr. N . krishnaraju |

vertical reinforcement as if the walls were fully fixed at the base, in addition to the reinforcement required to resist horizontal ring tension for hinged at base, conditions of walls, unless the appropriate amount of fixity at the base is established by analysis with due consideration to the dimensions of the base slab the type of joint between the wall and slab, and, where applicable, the type of soil supporting the base slab.

7. Roofs

(i) **Provision of Movement Joints.** To avoid the possibility of sympathetic cracking it is important to ensure that movement joints in the roof correspond with those in the walls, if roof and walls are monolithic. It, however, provision is made by means of a sliding joint for movement between the roof and the wall correspondence of joints is not so important.

(ii) **Loading.** Field covers of liquid retaining structures should be designed for gravity loads, such as the weight of roof slab, earth cover if any, live loads and mechanical equipment. They should also be designed for upward load if the liquid retaining structure is subjected to internal gas pressure.

A superficial load sufficient to ensure safety with the unequal intensity of loading which occurs during the placing of the earth cover should be allowed for in designing roofs. The engineer should specify a loading under these temporary conditions which should not be exceeded. In designing the roof, allowance should be made for the temporary condition of some spans loaded and other spans unloaded, even though in the final state the load may be small and evenly distributed.

(iii) **Water tightness.** In case of tanks intended for the storage of water for domestic purpose, the roof must be made water-tight. This may be achieved by limiting the stresses as for the rest of the tank, or by the use of the covering of the waterproof membrane or by providing slopes to ensure adequate drainage.

(iv) **Protection against corrosion.** Protection measure shall be provided to the underside of the roof to prevent it from corrosion due to condensation.

8. Minimum Reinforcement

(a) The minimum reinforcement in walls, floors and roofs in each of two directions at right angles shall have an area of 0.3 per cent of the concrete section in that direction for sections upto 100 mm, thickness. For sections of thickness greater than 100 mm, and less than 450 mm the minimum reinforcement in each of the two directions shall be linearly reduced from 0.3 percent for 100 mm. thick section to 0.2 percent for 450 mm, thick sections. For sections of thickness greater than 450 mm, minimum reinforcement in each of the two directions shall be kept at 0.2 per cent. In concrete sections of thickness 225 mm or greater, two layers of reinforcement steel shall be placed one near each face of the section to make up the minimum reinforcement.

(b) In special circumstances floor slabs may be constructed with percentage of

| | | |
|--|---|---|
| Subject code : CE 2401 |  VSA Educational and Charitable Trust's Group of Institutions, Salem – 636 010 Department of Civil Engineering | Chapter |
| Name of the subject : DESIGN OF REINFORCED CONCRETE & BRICK MASONRY STRUCTURES | | Reference details : |
| Date of deliverance : | | Design of RC Elements, Mr. N . krishnaraju |

reinforcement less than specified above. In no case the percentage of reinforcement in any member is less than 0.15% of gross sectional area of the member.

9. Minimum Cover to Reinforcement.

(a) For liquid faces of parts of members either in contact with the liquid (such as inner faces or roof slab) the minimum cover to all reinforcement should be 25 mm or the diameter of the main bar whichever is greater. In the presence of the sea water and soils and water of corrosive characters the cover should be increased by 12 mm but this additional cover shall not be taken into account for design calculations.

(b) For faces away from liquid and for parts of the structure neither in contact with the liquid on any face, nor enclosing the space above the liquid, the cover shall be as for ordinary concrete member.

5. Tanks Resting on Ground. For small capacities rectangular tanks are generally used and for bigger capacities circular tanks are used. The walls of circular tanks may have flexible joints or rigid joints at the base.

6. Circular Tanks with Flexible Joint at the Base. In these tanks walls are subjected to hydrostatic pressure. The tank wall is designed as thin cylinder.

At the base, minimum pressure
 $= wH.$

This causes hoop tension

$$= \frac{wHD}{2}$$

where

w is the density of water. H is depth of water, and D is diameter of the tank

Steel area required at the base for one metre height

$$= \frac{wHD}{2 \times 1000} \text{ cm}^2$$

If ' t ' is the thickness of wall, tensile stress in concrete

$$= \frac{wHD / 2}{100t + (m - 1)A_s} \text{ kg / cm}^2$$

| | | |
|--|--|--|
| Subject code : 080100048 |  VSA Educational and Charitable Trust's Group of Institutions, Salem – 636 010 Department of Civil Engineering | Chapter Reference details : |
| Name of the subject : DESIGN OF RC STRUCTURES | | Design of rc elements, Mr. N . krishnaraju |
| Date of deliverance : | | |

As the hoop tension reduces gradually to zero at top, the reinforcement is gradually reduced to minimum reinforcement at top. The main reinforcement consists of circular hoops Vertical reinforcement equal to 0.3% of concrete area is provided and hoop reinforcement is tied to this reinforcement. In smaller tanks main reinforcement is placed near the outer face. For bigger tanks the wall thickness is more and the reinforcement is placed on both faces.

Though assumed that base is flexible, but in reality there will always be some restraint at the base and some pressure will be resisted by cantilever action of the wall. The minimum vertical reinforcement provided will be adequate to resist bending stresses caused by cantilever action.

Example 1.

DESIGN OF UNDERGROUND WATER TANK

A reinforced concrete water tank resting on ground is 6 m × 2 m with a maximum depth of 2.5 m. Using M-20 concrete and Grade-I steel design the tank walls.

1. Data

Size of tank = 6 m × 2 m

Depth of tank = 2.5 m

M-20 concrete and Grade-I steel

2. Permissible stresses

$$\sigma_{cb} = 7 \text{ N/mm}^2$$

$$\sigma_{st} = 100 \text{ N/mm}^2 \text{ (on faces near water face)}$$

$$\sigma_{st} = 125 \text{ N/mm}^2 \text{ (on faces away from water face)}$$

$$m = 13, Q = 1.41, j = 0.84$$

| | | |
|--|--|--|
| Subject code : 080100048 |  VSA Educational and Charitable Trust's Group of Institutions, Salem – 636 010 Department of Civil Engineering | Chapter Reference details : |
| Name of the subject : DESIGN OF RC STRUCTURES | | Design of rc elements, Mr. N . krishnaraju |
| Date of deliverance : | | |

3. *Dimensions of tank*

$$L = 6 \text{ m}, B = 2 \text{ m}$$

$$\text{Ratio } \left(\frac{L}{B} \right) = \left(\frac{6}{2} \right) = 3 > 2$$

Long walls are designed as vertical cantilevers and short walls as spanning horizontally between long walls.

Maximum bending moment at base of :

$$\text{Long wall} = \left(\frac{wH^3}{6} \right) = \left(\frac{10 \times 2.5^3}{6} \right) = 26.04 \text{ kN.m}$$

$$d = \sqrt{\frac{M}{Q.b}} = \sqrt{\frac{26.04 \times 10^6}{1000 \times 1.41}} = 136 \text{ mm}$$

Using 16 mm diameter bars and 25 mm clear cover

Overall depth = 170 mm

Effective depth = 137 mm

$$\therefore A_{st} = \left(\frac{26.04 \times 10^6}{100 \times 0.84 \times 137} \right) = 2262 \text{ mm}^2$$

$$\text{Spacing of 16 mm bars} = \left(\frac{100 \times 201}{2262} \right) = 88.8 \text{ mm}$$

Adopt 16 mm diameter bars at 85 mm c/c. Spacing towards the top is increased to 170 mm c/c for the top 1 m.

| | | |
|--|--|--|
| Subject code : 080100048 |  VSA Educational and Charitable Trust's Group of Institutions, Salem – 636 010 Department of Civil Engineering | Chapter Reference details : |
| Name of the subject : DESIGN OF RC STRUCTURES | | Design of rc elements, Mr. N . krishnaraju |
| Date of deliverance : | | |

Intensity of pressure 1 m above base is :

$$p = w(H - h) = 10(2.5 - 1) = 15 \text{ kN/m}^2$$

$$\text{Direct tension in long walls} = T = \left(\frac{15 \times 2}{2} \right) = 15 \text{ kN}$$

$$\therefore A_{st} = \left(\frac{15 \times 10^3}{100} \right) = 150 \text{ mm}^2$$

$$\text{But minimum area} = 0.3\% = \left(\frac{0.3}{100} \times 170 \times 1000 \right) = 510 \text{ mm}^2$$

$$\text{Spacing of 10 mm diameter bars} = \left(\frac{1000 \times 79}{510} \right) = 154 \text{ mm}$$

Since steel is provided on both faces, provide 10 mm diameter bars at 300 mm c/c on both faces.

| | | |
|--|--|--|
| Subject code : 080100048 |  VSA Educational and Charitable Trust's Group of Institutions, Salem – 636 010 Department of Civil Engineering | Chapter Reference details : |
| Name of the subject : DESIGN OF RC STRUCTURES | | Design of rc elements, Mr. N . krishnaraju |
| Date of delivrance : | | |

$$\text{Spacing of 20 mm bars} = \left(\frac{1000 \times 314}{2558} \right) = 120 \text{ mm c/c}$$

(b) *Vertical steel*

Cantilever moment up to 1 m height from bottom

$$= \left(\frac{1}{2} \times 30 \times 1 \times \frac{1}{3} \right) = 5 \text{ kN.m}$$

$$\therefore A_{st} = \left(\frac{5 \times 10^6}{100 \times 0.84 \times 215} \right) = 276 \text{ mm}^2$$

$$\text{Minimum steel} = \left(\frac{0.3}{100} \times 250 \times 1000 \right) = 750 \text{ mm}^2$$

$$\text{Spacing of 10 mm bars} = \left(\frac{1000 \times 78.5}{750} \right) = 100 \text{ mm c/c}$$

Adopt 10 mm bars at 200 mm c/c at both faces.

(c) *Horizontal steel at mid span section (away from water face)*

$$\text{Maximum moment} = \left(\frac{pL^2}{16} \right) = \left(\frac{20 \times 5^2}{16} \right) = 31.25 \text{ kN.m}$$

$$\therefore A_{st} = \left[\frac{31.25 \times 10^6 - 50 \times 10^3 \times 90}{125 \times 0.86 \times 215} \right] + \left[\frac{50 \times 10^3}{125} \right] = 1657 \text{ mm}^2$$

Half the bars from inner face at support are bent towards outer face at centre providing an area of $(0.5 \times 2558) = 1279 \text{ mm}^2$.

$$\text{For remaining area} = (1657 - 1279) = 378 \text{ mm}^2$$

$$\text{Provide 10 mm bars at a spacing} = \left(\frac{100 \times 78.5}{378} \right) = 200 \text{ mm c/c}$$

The reinforcement details in the tank walls are shown

| | | |
|--|--|--|
| Subject code : 080100048 |  VSA Educational and Charitable Trust's Group of Institutions, Salem – 636 010 Department of Civil Engineering | Chapter Reference details : |
| Name of the subject : DESIGN OF RC STRUCTURES | | Design of rc elements, Mr. N . krishnaraju |
| Date of deliverance : | | |

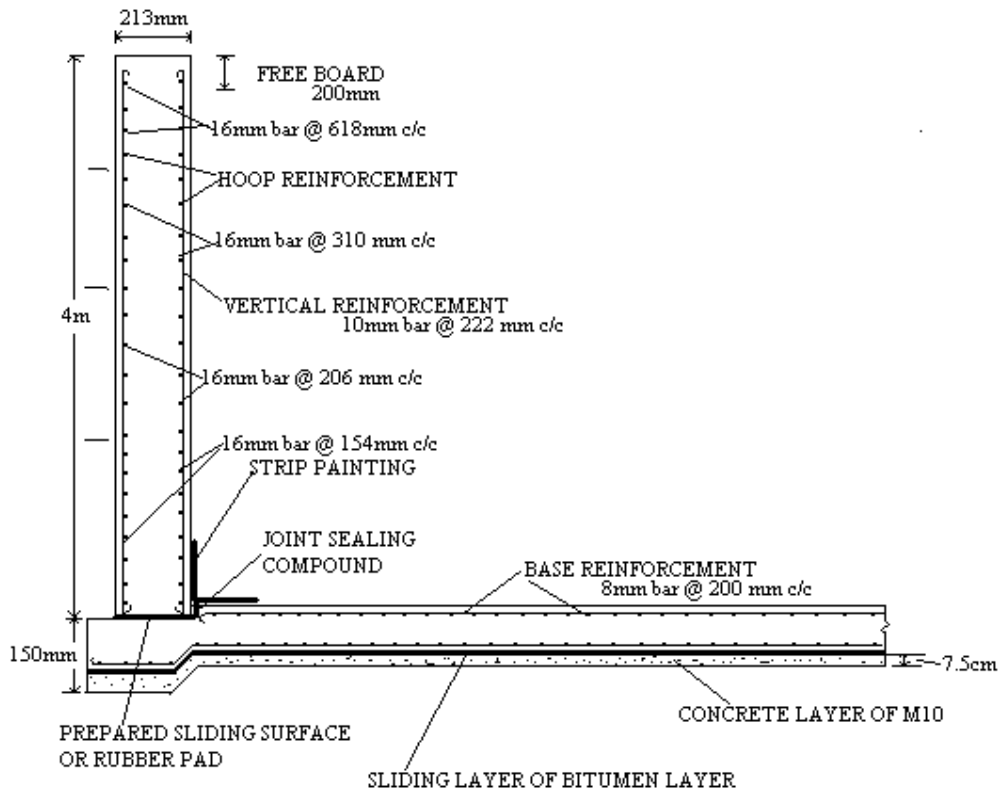

| | | |
|--|--|--|
| Subject code : 080100048 |  VSA Educational and Charitable Trust's Group of Institutions, Salem – 636 010 Department of Civil Engineering | Chapter Reference details : |
| Name of the subject : DESIGN OF RC STRUCTURES | | Design of rc elements, Mr. N . krishnaraju |
| Date of deliverance : | | |

DESIGN OF GROUND LEVEL CIRCULAR WATER TANK

Design a circular tank with a flexible base for capacity of 500,000 litres. The depth of water is to be 4 m. Free board = 200 mm. Use M-20 grade concrete and Grade-I mild steel. Permissible direct tensile stress in concrete = 1.2 N/mm². Permissible stress in steel in direct tension = 100 N/mm². Sketch the details of reinforcements in tank walls.

1. Data

Capacity of tank = 500,000 litres
Depth of water = 4 m
Free board = 200 mm
Density of water $w = 10 \text{ kN/m}^3$
M-20 concrete and Grade-I steel

2. Permissible stresses

Direct tensile stress in concrete (σ_{ct}) = 1.2 N/mm²
Tensile stress in steel = 100 N/mm²
Modular ratio $m = 13$

3. Dimensions of tank

Referring to Fig. 12.4(a), if D = Diameter of tank.

$$\left(\frac{\pi \cdot D^2}{4} \times 4 \right) = \left(\frac{500,000 \times 10^3}{10^6} \right)$$

$$\therefore D = 12.6 \text{ m}$$

4. Hoop tension and steel reinforcement

$$\text{Maximum hoop tension} = \left(\frac{wH.D}{2} \right) = \left(\frac{10 \times 4.2 \times 12.6}{2} \right) = 264.6 \text{ kN}$$

$$\therefore A_{st} = \left(\frac{264.6 \times 10^3}{100} \right) = 2646 \text{ mm}^2/\text{m height}$$

Using 20 mm diameter bars

$$\text{Spacing} = \left(\frac{1000 \times 314}{2646} \right) = 118 \text{ mm}$$

Provide 20 mm diameter bars at 118 mm c/c

5. Thickness of tank wall

If t = thickness of tank wall from cracking considerations

$$\left[\frac{\left(\frac{wH.d}{2} \right)}{1000t + (m - 1) A_{st}} \right] = \sigma_{ct} \therefore \left[\frac{264.6 \times 10^3}{1000t + (13 - 1)2646} \right] = 1.2$$

$$\therefore t = 188.7 \text{ mm}$$

Adopt 190 mm thick tank walls.

| | | |
|--|--|--|
| Subject code : 080100048 |  VSA Educational and Charitable Trust's Group of Institutions, Salem – 636 010 Department of Civil Engineering | Chapter Reference details : |
| Name of the subject : DESIGN OF RC STRUCTURES | | Design of rc elements, Mr. N . krishnaraju |
| Date of deliverance : | | |

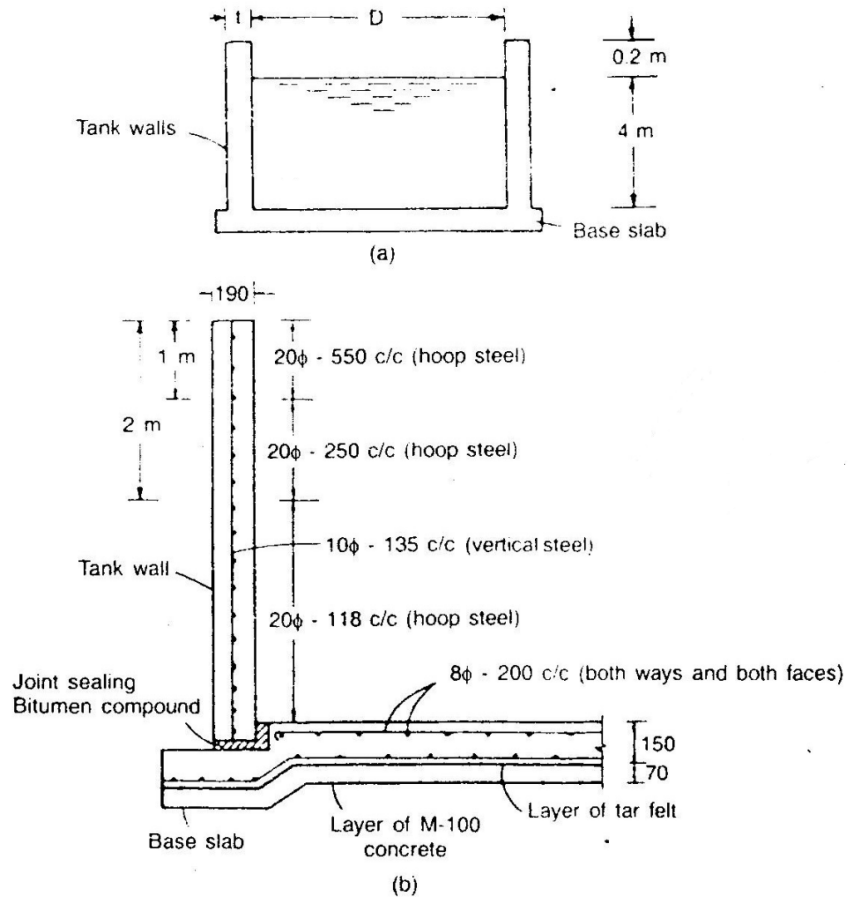

(a) Dimensions of circular tank, (b) Reinforcements in tank walls and base slab.

6. Reinforcements in tank wall

Spacing of hoops increased towards top. At top, minimum reinforcement 0.3%

$$A_{st} = \left(\frac{0.3}{100} \times 1000 \times 190 \right) = 570 \text{ mm}^2$$

∴ Spacing of hoops

$$\text{(Using 20 mm diameter bars)} = \left(\frac{1000 \times 314}{570} \right) = 550 \text{ mm}$$

Minimum spacing > 3 times the thickness of wall

$$> 3 \times 190$$

$$> 570 \text{ mm}$$

| | | |
|--|--|--|
| Subject code : 080100048 |  VSA Educational and Charitable Trust's Group of Institutions, Salem – 636 010 Department of Civil Engineering | Chapter Reference details : |
| Name of the subject : DESIGN OF RC STRUCTURES | | Design of rc elements, Mr. N . krishnaraju |
| Date of deliverance : | | |

Adopt 20 mm diameter hoops at 550 centres at top. Spacing at a depth of 2 m below the top.

$$A_{st} = \left[\frac{wHD/2}{100} \right] = \left[\frac{(0.5 \times 10 \times 2 \times 12.6)10^3}{100} \right] = 1260 \text{ mm}^2$$

$$\text{Spacing of 20 mm bars} = \left(\frac{1000 \times 314}{1260} \right) = 250 \text{ mm c/c}$$

Distribution and temperature reinforcement is provided in the vertical direction.

$$\text{Area of vertical steel} = 0.3\% = \left(\frac{0.3}{100} \times 1000 \times 190 \right) = 570 \text{ mm}^2$$

$$\text{Spacing of 10 mm bars} = \left(\frac{1000 \times 78.5}{570} \right) = 137 \text{ mm}$$

Use 10 mm diameter at 135 mm c/c.

7. Tank floor slab

Provide nominal thickness of 150 mm

$$\begin{aligned} \text{Minimum area of steel } A_{st} &= \left(\frac{0.3}{100} \times 150 \times 1000 \right) \\ &= 450 \text{ mm}^2 \text{ in each direction} \end{aligned}$$

Provide half the reinforcement near each face

$$\therefore A_{st} = 225 \text{ mm}^2$$

$$\text{Spacing of 8 mm diameter bars} = \left(\frac{1000 \times 50}{225} \right) = 220$$

Use 8 mm diameter bars at 100 mm c/c in both directions and on each face. The reinforcement details are shown in Fig.

| | | |
|--|--|--|
| Subject code : 080100048 |  VSA Educational and Charitable Trust's Group of Institutions, Salem – 636 010 Department of Civil Engineering | Chapter Reference details : |
| Name of the subject : DESIGN OF RC STRUCTURES | | Design of rc elements, Mr. N . krishnaraju |
| Date of deliverance : | | |

DESIGN OF GROUND LEVEL RECTANGULAR WATER TANK

A rectangular R.C. water tank with an open top is required to store 80,000 litres of water. The inside dimensions of tank may be taken as 6 m × 4 m. The tank rests on walls on all the four sides. Design the side walls of the tank using M-20 concrete and Grade-I steel.

1. Data

Capacity = 80,000 litres
Size of tank = 6 m × 4 m
Free board = 15 cm
M-20 concrete and Grade-I steel.

2. Permissible stresses

$\sigma_{cb} = 7 \text{ N/mm}^2$
 $\sigma_{st} = 100 \text{ N/mm}^2$ (on faces near water face)
 $\sigma_{st} = 125 \text{ N/mm}^2$ (on faces away from water face)
 $m = 13, Q = 1.41, j = 0.84$

3. Dimensions of tank

Refer to Fig. 12.7(a).

$$\text{Height of water} = \left(\frac{80,000 \times 10^3}{600 \times 400} \right) = 335 \text{ cm}$$

Free board = 15 cm

Height of side walls = (335 + 15) = 350 cm = 3.5 m

$(L/B) = 6/4 = 1.5 < 2$

∴ Walls designed as continuous slab subjected to water pressure above $(H/4)$ or 1 m from bottom.

$$\therefore p = w(H - h) \text{ at } xx = (10 \times 2.5) = 25 \text{ kN/m}^2$$

4. Moments in side walls

The moments in side walls is determined by moment distribution.

Fixed end moment :

Long walls

$$\left(\frac{p \cdot L^2}{12} \right) = \left(\frac{25 \times 6^2}{12} \right) = 75 \text{ kN.m} \quad \left(\frac{pB^2}{12} \right) = \left(\frac{25 \times 4^2}{12} \right) = 34 \text{ kN.m}$$

$$\left(\frac{p \cdot L^2}{8} \right) = \left(\frac{25 \times 6^2}{8} \right) = 112.5 \text{ kN.m} \quad \left(\frac{pB^2}{8} \right) = \left(\frac{25 \times 4^2}{8} \right) = 50 \text{ kN.m}$$

∴ Moment distribution is shown in Fig. 12.7(b).

Moment at support = 59 kN.m

At centre (long walls) = 53 kN.m = (112 – 59)

At centre (short walls) = –9 kN.m = (50 – 59)

The bending moment diagram is shown in Fig

| | | |
|--|--|--|
| Subject code : 080100048 |  VSA Educational and Charitable Trust's Group of Institutions, Salem – 636 010 Department of Civil Engineering | Chapter Reference details : |
| Name of the subject : DESIGN OF RC STRUCTURES | | Design of rc elements, Mr. N . krishnaraju |
| Date of deliverance : | | |

5. *Design of long and short walls*

Maximum moment = 59 kN.m

$$\therefore d = \sqrt{\frac{59 \times 10^6}{1.41 \times 1000}} = 204 \text{ mm}$$

(at xx)

Adopt overall depth = 250 mm and

Effective depth = 215 mm

$$\text{Direct tension in long wall} = T = \left(\frac{25 \times 4}{2} \right) = 50 \text{ kN}$$

$$\text{Direct tension in short wall} = T = \left(\frac{25 \times 6}{2} \right) = 75 \text{ kN}$$

$$A_{st} \text{ (long wall corners)} = \left[\frac{M - T_x}{\sigma_{st} \cdot d \cdot j} \right] + \frac{T}{\sigma_{st}}$$

Referring to Fig. 12.7(d)

$$\therefore A_{st} = \left[\frac{(59 \times 10^6) - (50 \times 10^3 \times 90)}{100 \times 0.84 \times 215} \right] + \left(\frac{50 \times 10^3}{100} \right) = 3480 \text{ mm}^2$$

$$\text{Spacing of 20 mm bars} = \left(\frac{1000 \times 314}{3480} \right) = 90 \text{ mm c/c}$$

| | | |
|--|--|--|
| Subject code : 080100048 |  VSA Educational and Charitable Trust's Group of Institutions, Salem – 636 010 Department of Civil Engineering | Chapter Reference details : |
| Name of the subject : DESIGN OF RC STRUCTURES | | Design of rc elements, Mr. N . krishnaraju |
| Date of deliverance : | | |

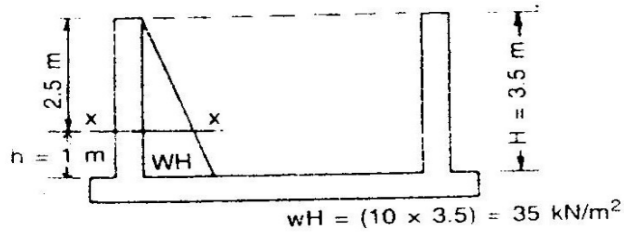

(a) Tank dimensions

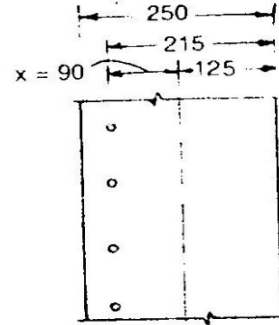

| | | | | |
|-----|-----|-----|-----|-----|
| 0.4 | | 6 m | 0.4 | |
| 0.6 | | | | 0.6 |
| +34 | -75 | | +75 | -34 |
| +25 | +16 | | -16 | -25 |
| +59 | -59 | | +59 | -59 |

(b) Moment distribution

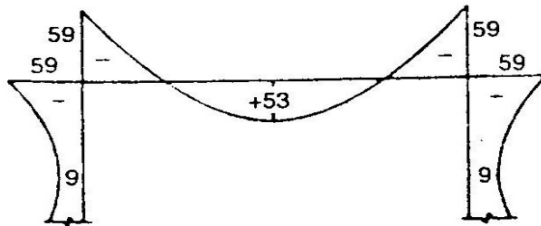

(c) Bending moments

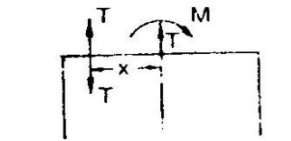

Net moment = $(M - Tx)$
 T = pull in steel

(d) Moments in cross section

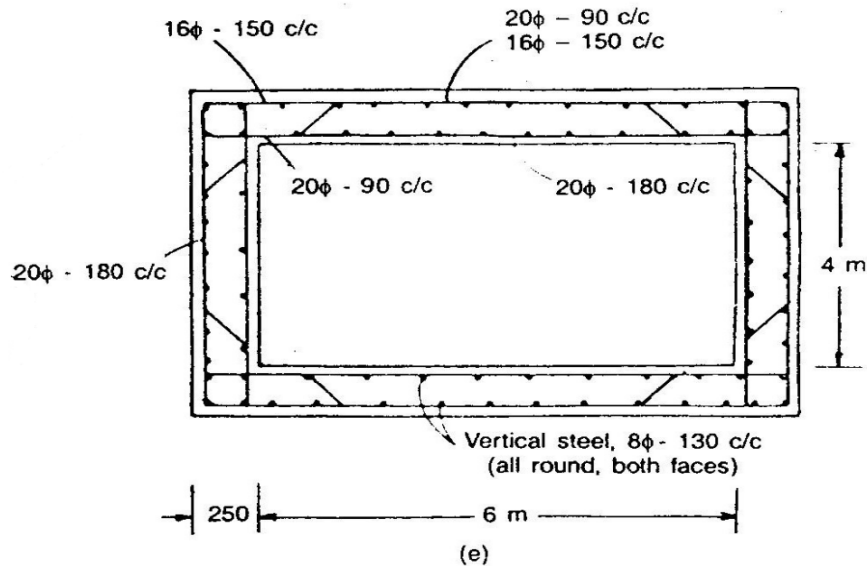

(e)

Reinforcement details in water tank ($L/B < 2$).

| | | |
|--|--|--|
| Subject code : 080100048 |  VSA Educational and Charitable Trust's Group of Institutions, Salem – 636 010 Department of Civil Engineering | Chapter Reference details : |
| Name of the subject : DESIGN OF RC STRUCTURES | | Design of rc elements, Mr. N . krishnaraju |
| Date of deliverance : | | |

DESIGN OF OVERHEAD WATER TANK

Design an overhead flat bottomed R.C.C. cylindrical water tank to store 100 kl of water. The top of the tank is covered with a dome. Height of staging = 12 m above ground level. Provide 2 m depth of foundation. Intensity of wind pressure may be taken as 1.5 kN/m². Safe bearing capacity of soil at site is 100 kN/m². Adopting M-20 grade concrete and Fe-415 grade tor steel design the following :

- (a) Size of tank
- (b) Ring beam at junction of dome and side walls
- (c) Side walls of tank
- (d) Bottom ring girder
- (e) Tank floor slab
- (f) Bracing at 4 m intervals
- (g) R.C. columns assuming six column supports
- (h) Foundation for the tank.

1. Data

Capacity of tank = 100 kl
Height of supporting tower = 12 m
Number of supporting columns = 6
Depth of foundations = 2 m below ground level
Safe bearing capacity of soil = 250 kN/m²

2. Permissible stresses

M-20 grade concrete and Fe-415 grade tor steel for calculations relating to resistance to cracking (IS : 3310).

$$\sigma_{ct} = 1.2 \text{ N/mm}^2 \quad \sigma_{st} = 150 \text{ N/mm}^2$$

For strength calculations, the stresses in concrete and steel are the same as that recommended in IS : 456 code.

$$\begin{aligned} \sigma_{cc} &= 5 \text{ N/mm}^2 & m &= 13 \\ \sigma_{cb} &= 7 \text{ N/mm}^2 & Q &= 0.897 \\ & & j &= 0.90 \end{aligned}$$

3. Dimensions of tank

Let D = Inside diameter of the tank
Assuming an average depth = $0.6 D$, we have

$$\left(\frac{\pi D^2}{4} \times 0.6 D \right) = 100 \times 10^3 \text{ litres} = 100 \text{ m}^3$$

$$\therefore D = 6 \text{ m}$$

Height of storage = $(0.6 \times 6) = 3.6 \text{ m}$
Free board = 0.2 m
Height of cylindrical portion = 3.8 m

| | | |
|--|--|--|
| Subject code : 080100048 |  VSA Educational and Charitable Trust's Group of Institutions, Salem – 636 010 Department of Civil Engineering | Chapter Reference details : |
| Name of the subject : DESIGN OF RC STRUCTURES | | Design of rc elements, Mr. N . krishnaraju |
| Date of deliverance : | | |

4. Design of top dome

$$\begin{aligned}
\text{Thickness of dome slab} &= t = 100 \text{ mm} \\
\text{Live load on dome} &= 1.5 \text{ kN/m}^2 \\
\text{Self weight of dome} &= (0.1 \times 24) = 2.4 \text{ kN/m}^2 \\
\text{Finishes} &= 0.1 \\
\text{Total load} &= w = 4.0 \text{ kN/m}^2
\end{aligned}$$

If R = Radius of dome
 D = Diameter at base = 6 m
 r = Central rise = 1 m

$$R = \left[\frac{(D/2)^2 + r^2}{2r} \right] = \left[\frac{3^2 + 1^2}{2 \times 1} \right] = 5 \text{ m}$$

$$\cos \theta = (4/5) = 0.8$$

$$\therefore \theta = 36^\circ 50'$$

$$\begin{aligned}
\text{Meridional thrust} = T_1 &= \left(\frac{w \cdot R}{1 + \cos \theta} \right) \\
&= \left(\frac{4 \times 5}{1 + 0.8} \right) = 11.1 \text{ kN/m}
\end{aligned}$$

$$\begin{aligned}
\text{Circumferential force} &= w \cdot R \left[\cos \theta - \frac{1}{(1 + \cos \theta)} \right] \\
&= (4 \times 5) \left[0.8 - \frac{1}{1.8} \right] = 5 \text{ kN/m}
\end{aligned}$$

$$\text{Meridional stress} = \left(\frac{11.1 \times 10^3}{1000 \times 100} \right) = 0.11 \text{ N/mm}^2 < 5 \text{ N/mm}^2$$

$$\text{Hoop stress} = \left(\frac{5 \times 10^3}{1000 \times 100} \right) = 0.05 \text{ N/mm}^2 < 5 \text{ N/mm}^2$$

The stresses in dome are within safe permissible limits. Providing nominal reinforcements of 0.3 per cent :

$$A_{st} = \left(\frac{0.3 \times 100 \times 1000}{100} \right) = 300 \text{ mm}^2$$

Provide 8 mm diameter bars at 160 mm centres both circumferentially and meridionally.

5. Design of top ring beam

$$\text{Hoop tension } F_t = \left(\frac{T_1 \cdot \cos \theta \cdot D}{2} \right) = \left(\frac{11.1 \times 0.8 \times 6}{2} \right) = 27 \text{ kN}$$

| | | |
|--|--|--|
| Subject code : 080100048 |  VSA Educational and Charitable Trust's Group of Institutions, Salem – 636 010 Department of Civil Engineering | Chapter Reference details : |
| Name of the subject : DESIGN OF RC STRUCTURES | | Design of rc elements, Mr. N . krishnaraju |
| Date of deliverance : | | |

$$\text{Depth of dome} = \left(\frac{1}{6} \times 6 \right) = 1 \text{ m}$$

Diameter of dome = 6 m

Spacings of bracings = 4 m

The salient dimensions of the tank and the staging is shown in Fig

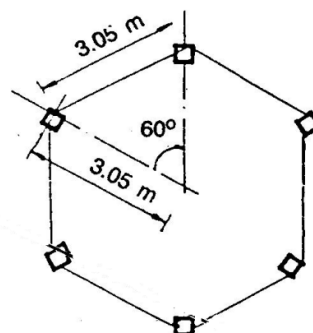
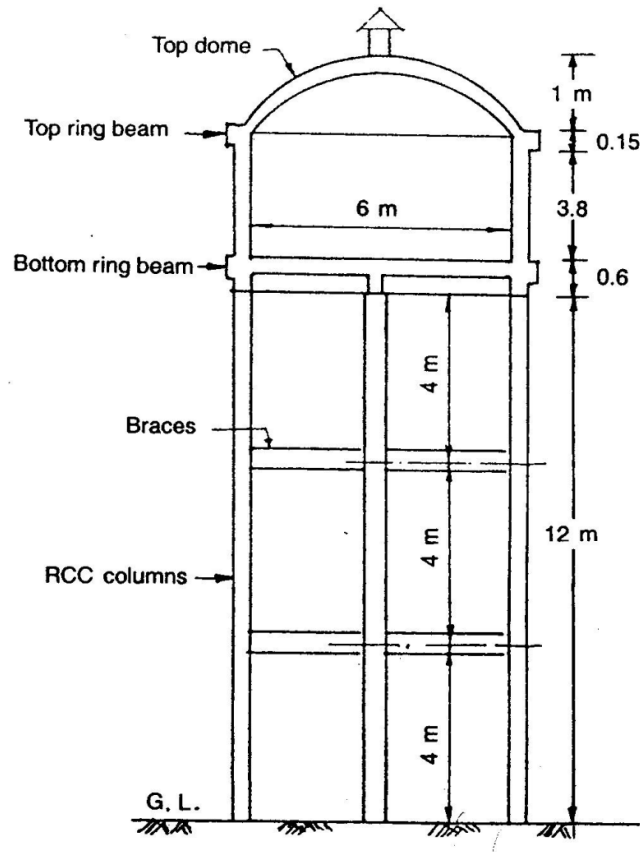

Salient dimensions of tank.

| | | |
|--|--|--|
| Subject code : 080100048 |  VSA Educational and Charitable Trust's Group of Institutions, Salem – 636 010 Department of Civil Engineering | Chapter Reference details : |
| Name of the subject : DESIGN OF RC STRUCTURES | | Design of rc elements, Mr. N . krishnaraju |
| Date of deliverance : | | |

$$A_{st} = \left(\frac{27 \times 10^3}{150} \right) = 180 \text{ mm}^2$$

Provide 4 bars of 8 mm diameter with 6 mm diameter stirrups at 150 mm centres. ($A_{st} = 200 \text{ mm}^2$)
If A_c = cross sectional area of ring beam, we have :

$$\left[\frac{27 \times 10^3}{A_c + (m - 1) A_{st}} \right] = 1.2$$

$$\left[\frac{27 \times 10^3}{A_c + (13 - 1) 200} \right] = 1.2$$

Solving $A_c = 20340 \text{ mm}^2$

Adopt a ring beam of size 150 mm by 150 mm.

6. Design of cylindrical tank wall

Maximum hoop tension at base of wall is given by :

$$F_t = \left(\frac{w \cdot H \cdot D}{2} \right) = \left(\frac{10 \times 3.6 \times 6}{2} \right) = 108 \text{ kN/m}$$

$$A_{st} = \left(\frac{T}{\sigma_{st}} \right) = \left(\frac{108 \times 10^3}{150} \right) = 720 \text{ mm}^2/\text{m}$$

Provide 12 mm diameter bars at 150 mm centres at the bottom of the tank ($A_{st} = 754 \text{ mm}^2$)

If t = thickness of tank wall at bottom of tank, then

$$\left[\frac{T}{A_c + (m - 1) A_{st}} \right] = \sigma_{ct}$$

$$\left[\frac{108 \times 10^3}{100t + (12 \times 754)} \right] = 1.2$$

Solving, the thickness, $t = 81 \text{ mm}$

Adopt 100 mm thick walls uniform upto the top of the tank.

Minimum reinforcement = 0.24 per cent

$$= \left(\frac{0.24 \times 100 \times 1000}{100} \right) = 240 \text{ mm}^2/\text{m}$$

Provide 12 mm diameter hoops at 300 mm centres for the top one metre. For the middle one metre, adopt a spacing of 225 mm c/c.

$$\text{Distribution steel} = A_{st} = \left(\frac{0.2 \times 100 \times 1000}{100} \right) = 200 \text{ mm}^2$$

Provide 12 mm diameter bars at 300 mm centres in the vertical direction.

| | | |
|--|--|--|
| Subject code : 080100048 |  VSA Educational and Charitable Trust's Group of Institutions, Salem – 636 010 Department of Civil Engineering | Chapter Reference details : |
| Name of the subject : DESIGN OF RC STRUCTURES | | Design of rc elements, Mr. N . krishnaraju |
| Date of deliverance : | | |

7. Tank floor slab

The tank floor slab is circular and fixed at the periphery to the circular ring beam.

Load on the circular slab = w

$$= (\text{weight of water}) + (\text{self weight of slab assumed as 300 mm thick})$$

$$= (10 \times 3.6) + (0.3 \times 24)$$

$$\therefore w = 43.2 \text{ kN/m}^2$$

(a) Maximum radial and circumferential moments

Positive moment at centre of span is :

$$M_{tp} = \left(\frac{3}{16} w \cdot r^2 \right) = \left(\frac{3}{16} \times 43.2 \times 3^2 \right) = 73 \text{ kN.m}$$

Negative moment at supports is :

$$M_m = \left(\frac{w \cdot r^2}{8} \right) = \left(\frac{43.2 \times 3^2}{8} \right) = 50 \text{ kN.m}$$

Circumferential moment is given by the relation :

$$M_c = \left(\frac{w \cdot r^2}{16} \right) = \left(\frac{43.2 \times 3^2}{16} \right) = 26 \text{ kN.m}$$

Effective depth of the slab is given by :

$$d = \sqrt{\frac{M}{Q \cdot b}} = \sqrt{\frac{73 \times 10^6}{1.009 \times 1000}} = 268 \text{ mm}$$

Adopt $d = 270 \text{ mm}$ and overall depth = 300 mm

(b) Reinforcements in circular slab

$$A_{st} (\text{Centre of span}) = \left[\frac{73 \times 10^6}{190 \times 0.89 \times 270} \right] = 1395 \text{ mm}^2$$

$$A_{st} (\text{Supports}) = \left[\frac{50 \times 10^6}{150 \times 0.88 \times 270} \right] = 1402 \text{ mm}^2$$

$$A_{st} (\text{Circumferential moment}) = \left[\frac{26 \times 10^6}{150 \times 0.88 \times 270} \right] = 730 \text{ mm}^2$$

Provide 16 mm diameter bars at 120 mm centres both ways at bottom and for a length of 1.2 m from supports at top, radially and circumferentially.

| | | |
|--|--|--|
| Subject code : 080100048 |  VSA Educational and Charitable Trust's Group of Institutions, Salem – 636 010 Department of Civil Engineering | Chapter Reference details : |
| Name of the subject : DESIGN OF RC STRUCTURES | | Design of rc elements, Mr. N . krishnaraju |
| Date of deliverance : | | |

8. Bottom ring beam

(a) Total load on ring beam :

$$\begin{aligned}
\text{Weight of water} &= 1000 \text{ kN} \\
\text{Load from dome} = (2 \cdot \pi \cdot R \cdot r \cdot w) = (2 \times \pi \times 5 \times 1 \times 4) &= 126 \text{ kN} \\
\text{Weight of top ring beam} = (0.15 \times 0.15 \times 24 \times \pi \times 6.15) &= 10.4 \text{ kN} \\
\text{Weight of cylindrical wall} = (\pi \times 6.1 \times 0.1 \times 3.8 \times 24) &= 175 \text{ kN} \\
\text{Weight of floor slab} = (\pi \times 3^2 \times 0.3 \times 24) &= 203.5 \text{ kN} \\
\text{Weight of bottom ring beam} \\
\text{(Rib section of 300 by 400 mm)} = (0.3 \times 0.4 \times \pi \times 6.1 \times 24) &= 55.1 \text{ kN} \\
\text{Total vertical load on beam} &= W = 1570 \text{ kN}
\end{aligned}$$

Uniformly distributed load per metre on girder is :

$$= \left(\frac{W}{\pi \cdot D} \right) = \left(\frac{1570}{\pi \times 6.1} \right) = 82 \text{ kN/m}$$

(b) Moments and shear forces in ring beam :

Assuming six columns supporting the ring beam, the moments are as follows :

$$\begin{aligned}
\text{Negative } B.M \text{ at supports} &= 0.0148 W.R \\
&= (0.0148 \times 1570 \times 3.05) = 71 \text{ kN.m}
\end{aligned}$$

$$\begin{aligned}
\text{Positive } B.M \text{ at centre of supports} &= 0.0075 W.R \\
&= (0.0075 \times 1570 \times 3.05) \\
&= 36 \text{ kN.m}
\end{aligned}$$

$$\begin{aligned}
\text{Torsional moment} &= 0.0015 W.R \\
&= (0.0015 \times 1570 \times 3.05) = 7.5 \text{ kN.m}
\end{aligned}$$

$$\begin{aligned}
\text{Shear force at support} = V &= \left[\frac{\text{Total load}}{2 \times \text{number of columns}} \right] \\
&= \left(\frac{1570}{2 \times 6} \right) = 131 \text{ kN}
\end{aligned}$$

Shear force at section of maximum torsion is given by :

$$V = \left[131 - \frac{(82 \times 3.05 \times \pi \times 12.73)}{180} \right] = 76 \text{ kN}$$

(c) Design of support section

$$\text{Bending moment} = M = 71 \text{ kN.m}$$

$$\text{Shear force} = V = 131 \text{ kN}$$

$$\text{Effective depth} = \sqrt{\frac{M}{Q.b}} = \sqrt{\frac{71 \times 10^6}{1.14 \times 300}} = 455 \text{ mm}$$

| | | |
|--|--|--|
| Subject code : 080100048 |  VSA Educational and Charitable Trust's Group of Institutions, Salem – 636 010 Department of Civil Engineering | Chapter Reference details : |
| Name of the subject : DESIGN OF RC STRUCTURES | | Design of rc elements, Mr. N . krishnaraju |
| Date of delivrance : | | |

Adopt $d = 550$ mm and overall depth = 600 mm

$$\therefore A_{st} = \left(\frac{71 \times 10^6}{150 \times 0.88 \times 550} \right) = 978 \text{ mm}^2$$

Provide 4 bars of 20 mm diameter ($A_{st} = 1256 \text{ mm}^2$)

$$\tau_v = \left(\frac{V}{b.d} \right) = \left(\frac{131 \times 10^3}{400 \times 550} \right) = 0.595 \text{ N/mm}^2$$

$$\left(\frac{100 A_{st}}{b.d} \right) = \left(\frac{100 \times 1256}{400 \times 500} \right) = 0.57$$

From Table 23 of IS : 456 code, $\tau_c = 0.31 \text{ N/mm}^2 < \tau_v$
Hence shear reinforcements are required.

$$\text{Shear resisted by concrete} = \left(\frac{0.31 \times 400 \times 550}{1000} \right) = 68 \text{ kN}$$

Balance shear = $(131 - 68) = 63 \text{ kN}$

Using 10 mm diameter two-legged stirrups, the spacing is given by :

$$s_v = \left(\frac{150 \times 2 \times 79 \times 550}{63 \times 10^3} \right) = 206 \text{ mm}$$

Adopt 10 mm diameter, two-legged stirrups at 200 mm centres.

(d) *Design of centre of span section*

Bending moment = $M = 36 \text{ kN.m}$

$$A_{st} = \left(\frac{36 \times 10^6}{190 \times 0.89 \times 550} \right) = 345 \text{ mm}^2$$

Minimum quantity of steel is obtained as :

$$A_s = \left(\frac{0.85 b.d}{f_y} \right) = \left(\frac{0.85 \times 400 \times 550}{415} \right) = 450 \text{ mm}^2$$

Provide 2 bars of 20 mm diameter ($A_{st} = 628 \text{ mm}^2$)

(e) *Design of section subjected to maximum torsion and shear*

Torsional moment = $T = 7.5 \text{ kN.m}$

Shear force = $V = 76 \text{ kN}$

Bending moment = $M = 0$

| | | |
|--|--|--|
| Subject code : 080100048 |  VSA Educational and Charitable Trust's Group of Institutions, Salem – 636 010 Department of Civil Engineering | Chapter Reference details : |
| Name of the subject : DESIGN OF RC STRUCTURES | | Design of rc elements, Mr. N . krishnaraju |
| Date of deliverance : | | |

Overall depth = $D = 600$ mm

Width of section = $b = 400$ mm

$$M_s = T \left[\frac{1 + (D/b)}{1.7} \right] = 7.5 \left[\frac{1 + (600/400)}{1.7} \right] = 11 \text{ kN.m}$$

$$M_c = (M + M_s) = (0 + 11) = 11 \text{ kN.m}$$

$$A_{st} = \left(\frac{11 \times 10^6}{190 \times 0.89 \times 550} \right) = 118 \text{ mm}^2$$

But minimum reinforcement = 450 mm^2

Provide 2 bars of 20 mm diameter.

$$V_c = V + 1.6 (T/b) \\ = [76 + 1.6 (7.5/0.4)] = 106 \text{ kN}$$

$$\tau_{ve} = \left(\frac{106 \times 10^3}{400 \times 550} \right) = 0.48 \text{ N/mm}^2$$

$$\left(\frac{100 A_{st}}{b.d} \right) = \left(\frac{100 \times 450}{400 \times 550} \right) = 0.20$$

$$\therefore \tau_c = 0.20 \text{ N/mm}^2 < \tau_{ve}$$

Hence shear reinforcements are required. Using 10 mm diameter two-legged stirrups with side covers of 25 mm and top and bottom covers of 50 mm, we have :

$$b_1 = 350 \text{ mm}, d_1 = 500 \text{ mm and } A_{sv} = (2 \times 79) = 158 \text{ mm}^2$$

$$s_v = \left[\frac{A_{sv} \cdot \sigma_{sv}}{(\tau_{ve} - \tau_c)b} \right] = \left[\frac{158 \times 150}{(0.48 - 0.20) 400} \right] = 211 \text{ mm}$$

Adopt 10 mm diameter two-legged stirrups at 200 mm centres.

9. Supporting tower

(a) Load on columns

Total load from ring beam = 1570 kN

Load on each column = $(1570/6) = 262$ kN

Self weight of columns $(400 \times 40 \text{ mm}) = 0.4 \times 0.4 \times 12 \times 25$
= 47 kN

Self weight of braces $(350 \times 450 \text{ mm}) = (2 \times 0.35 \times 0.45 \times 3.05 \times 24)$
= 23 kN

Total load on each column (Tank full) = $(262 + 47 + 23) = 332$ kN

Total axial load on each column (Tank empty) = $(1570 - 1000)/6 + 47 + 23 = 165$ kN

| | | |
|--|--|--|
| Subject code : 080100048 |  VSA Educational and Charitable Trust's Group of Institutions, Salem – 636 010 Department of Civil Engineering | Chapter Reference details : |
| Name of the subject : DESIGN OF RC STRUCTURES | | Design of rc elements, Mr. N . krishnaraju |
| Date of deliverance : | | |

(b) *Wind forces*

Intensity of wind pressure = 1.5 kN/m²

Reduction coefficient for circular shape = 0.7

(i) Wind force on top of dome and cylindrical wall (including bottom ring beam)

$$= (0.7 \times 1.5 \times 5.35 \times 6.2) = 35 \text{ kN}$$

(ii) Wind force on columns = (6 × 0.4 × 12 × 1.5) = 43 kN

(iii) Wind force on braces = (2 × 6.1 × 4.5 × 1.5) = 8.2 kN

$$\therefore \text{Total horizontal wind force} = (35 + 43 + 8.2) = 86.2 \text{ kN}$$

Assuming contra flexure points at mid height of columns and fixity at the base due to raft foundations, the moment at the base of columns is obtained as :

$$M = (0.5 \times 86.2 \times 4) = 173 \text{ kN.m}$$

If M_1 = Moment at the base of columns due to wind loads

$$= (35 \times 14.675) + (43 \times 6) + (8.2 \times 6)$$

$$= 821 \text{ kN.m}$$

If V = Reaction developed at base of exterior columns

$$M_1 = \Sigma M + \frac{V}{r_1} \Sigma r^2$$

where $r_1 = 3.05 \cos 30^\circ = 2.64 \text{ m}$

$$r_2 = 4 (2.64)^2 = 27.87$$

$$\therefore 821 = 173 + \left(\frac{V}{2.64} \times 27.87 \right)$$

Solving, $V = 62 \text{ kN}$

\therefore Total load on leeward column at base is obtained as :

$$P = (332 + 62) = 394 \text{ kN}$$

Moment in each column at base is :

$$M = (173/6) = 29 \text{ kN.m}$$

$$\text{Eccentricity} = e = (M/P) = \left(\frac{29 \times 10^6}{394 \times 10^3} \right) = 74 \text{ mm}$$

Since eccentricity is small, direct stresses are predominant.

Using 8 bars of 16 mm diameter equally spaced on all faces :

$$A_{sc} = (8 \times 201) = 1608 \text{ mm}^2$$

$$A_e = [(400 \times 400) - 1608] + [1.5 \times 13 \times 1608]$$

$$= 189748 \text{ mm}^2$$

$$I_e = \left(\frac{400 \times 400^3}{12} \right) + (2 \times 1.5 \times 13 \times 3 \times 201 \times 150^2)$$

| | | |
|--|--|--|
| Subject code : 080100048 |  VSA Educational and Charitable Trust's Group of Institutions, Salem – 636 010 Department of Civil Engineering | Chapter Reference details : |
| Name of the subject : DESIGN OF RC STRUCTURES | | Design of rc elements, Mr. N . krishnaraju |
| Date of deliverance : | | |

$$\text{Direct compressive stress} = \sigma'_{cc} = \left(\frac{394 \times 10^3}{189748} \right) = 2.07 \text{ N/mm}^2$$

$$\text{Bending stress} = \sigma'_{cb} = \left(\frac{29 \times 10^6 \times 200}{265 \times 10^7} \right) = 2.18 \text{ N/mm}^2$$

Permissible stress in concrete is increased by 33.33 per cent while considering wind effects.

$$\text{Hence} \quad \left(\frac{\sigma'_{cc}}{\sigma_{cc}} + \frac{\sigma'_{cb}}{\sigma_{cb}} \right) < 1$$

$$\left(\frac{2.07}{5 \times 1.33} + \frac{2.18}{7 \times 1.33} \right) = 0.54 < 1$$

The stresses are within safe permissible limits. Adopt 6 mm diameter ties at 250 mm centres.

10. Design of bracings

$$\begin{aligned} \text{Moment in brace} &= (2 \times \text{moment in column} \times \sec 30^\circ) \\ &= (2 \times 29 \times 1.15) 67 \text{ kN.m} \end{aligned}$$

$$\begin{aligned} \text{Section of brace} &= (350 \times 450) \text{ mm} \\ b &= 350 \text{ mm} \\ d &= 400 \text{ mm} \end{aligned}$$

Moment of resistance of section is given by :

$$\begin{aligned} M_1 &= (0.897 \times 350 \times 400^2) / 10^6 \\ &= 50 \text{ kN.m} \end{aligned}$$

$$\begin{aligned} \text{Balance moment} &= M_2 = (M - M_1) \\ &= (67 - 50) \\ &= 17 \text{ kN.m} \end{aligned}$$

$$A_{st1} = \left(\frac{50 \times 10^6}{230 \times 0.9 \times 400} \right) = 604 \text{ mm}^2$$

$$A_{st2} = \left(\frac{17 \times 10^6}{230 \times 0.9 \times 350} \right) = 235 \text{ mm}^2$$

$$\therefore A_{st} = (604 + 235) = 839 \text{ mm}^2$$

Provide 3 bars of 20 mm diameter at top and bottom since wind direction is reversible
($A_{st} = 942 \text{ mm}^2$)

$$\text{Length of brace} = (2 \times 3.05 \times \sin 30) = 3.05 \text{ m}$$

| | | |
|--|--|--|
| Subject code : 080100048 |  VSA Educational and Charitable Trust's Group of Institutions, Salem – 636 010 Department of Civil Engineering | Chapter Reference details : |
| Name of the subject : DESIGN OF RC STRUCTURES | | Design of rc elements, Mr. N . krishnaraju |
| Date of deliverance : | | |

Maximum shear force in brace :

$$\begin{aligned}
&= \left(\frac{\text{Moment in brace}}{1/2 \text{ Length of brace}} \right) \\
&= \left(\frac{67}{0.5 \times 3.05} \right) = 44 \text{ kN} \\
\tau_v &= \left(\frac{44 \times 10^3}{350 \times 400} \right) = 0.31 \text{ N/mm}^2 \\
&= \left(\frac{100 A_{st}}{bd} \right) = \left(\frac{100 \times 942}{350 \times 400} \right) = 0.67
\end{aligned}$$

From Table 23 of IS : 456 Code, $\tau_c = 0.33 \text{ N/mm}^2$.
Since $\tau_c > \tau_v$, provide nominal shear reinforcements.
Using 6 mm diameter 2 legged stirrups :

$$\text{Spacing, } s_v = \left(\frac{A_{sy} f_y}{0.4b} \right) = \left(\frac{2 \times 28 \times 415}{0.4 \times 350} \right) = 166 \text{ mm}$$

Adopt 6 mm diameter, 2-legged stirrups at 160 mm c/c.

11. Design of foundations

(a) Circular girder

A circular girder with a raft slab is provided for the tower foundations.

$$\text{Total load on foundation} = (332 \times 6) = 1992 \text{ kN}$$

$$\text{Self weight of foundation at 10\%} = 198$$

$$\text{Total load} = 2190 \text{ kN}$$

$$\text{Safe bearing capacity of soil at site} = 100 \text{ kN/m}^2$$

$$\therefore \text{Area of foundation} = \left(\frac{2190}{100} \right) = 21.90 \text{ m}^2$$

If b = Width of footing required

$$(\pi \times 6.1 \times b) = 21.90$$

$$\therefore b = 1.14 \text{ m}$$

Adopt width of footing = 1.5 m and a circular girder with a width of 500 mm

$$\text{Total load on ring girder} = W = 2190 \text{ kN}$$

$$\text{Load per metre run of girder} = \left(\frac{2190}{\pi \times 6.1} \right) = 115 \text{ kN/m}$$

| | | |
|--|--|--|
| Subject code : 080100048 |  VSA Educational and Charitable Trust's Group of Institutions, Salem – 636 010 Department of Civil Engineering | Chapter Reference details : |
| Name of the subject : DESIGN OF RC STRUCTURES | | Design of rc elements, Mr. N . krishnaraju |
| Date of deliverance : | | |

$$\begin{aligned}
\text{Maximum negative moment at support} &= 0.0148 WR \\
&= (0.0148 \times 2190 \times 3.05) \\
&= 99 \text{ kN.m}
\end{aligned}$$

$$\begin{aligned}
\text{Maximum positive moment at mid span} &= 0.0075 WR \\
&= (0.0075 \times 2190 \times 3.05) \\
&= 50 \text{ kN.m}
\end{aligned}$$

$$\begin{aligned}
\text{Maximum torsional moment (at } 12^\circ 44' \text{ from either support)} &= 0.0015 WR \\
&= (0.0015 \times 2190 \times 3.05) \\
&= 10 \text{ kN.m}
\end{aligned}$$

Shear force at support section is obtained as :

$$\begin{aligned}
V &= \left[\frac{\text{Total load}}{2 \times \text{No. of columns}} \right] \\
&= \left(\frac{2190}{2 \times 6} \right) \\
&= 182.5 \text{ kN}
\end{aligned}$$

Shear force at section of maximum torsion is :

$$V = \left[182.5 - \frac{115 \times \pi \times 3.05 \times 12.73}{180} \right] = 105 \text{ kN}$$

The support section is designed for a maximum negative moment of $M = 99 \text{ kN.m}$ and shear force $V = 182.5 \text{ kN}$. Assuming a width $b = 500 \text{ mm}$

$$\text{Effective depth } d = \sqrt{\frac{99 \times 10^6}{0.897 \times 500}} = 470 \text{ mm}$$

Adopt $d = 500 \text{ mm}$ and overall depth = 550 mm

$$A_{st} = \left(\frac{99 \times 10^6}{230 \times 0.9 \times 500} \right) = 957 \text{ mm}^2$$

Provide 4 bars of 20 mm diameter bars ($A_{st} = 1256 \text{ mm}^2$)

$$\tau_v = \left(\frac{182.5 \times 10^3}{500 \times 500} \right) = 0.73 \text{ N/mm}^2$$

$$\left(\frac{100 A_{st}}{bd} \right) = \left(\frac{100 \times 1256}{500 \times 500} \right) = 0.50$$

From Table 23 of IS : 456 code, $\tau_c = 0.30 \text{ N/mm}^2$

| | | |
|--|--|--|
| Subject code : 080100048 |  VSA Educational and Charitable Trust's Group of Institutions, Salem – 636 010 Department of Civil Engineering | Chapter Reference details : |
| Name of the subject : DESIGN OF RC STRUCTURES | | Design of rc elements, Mr. N . krishnaraju |
| Date of deliverance : | | |

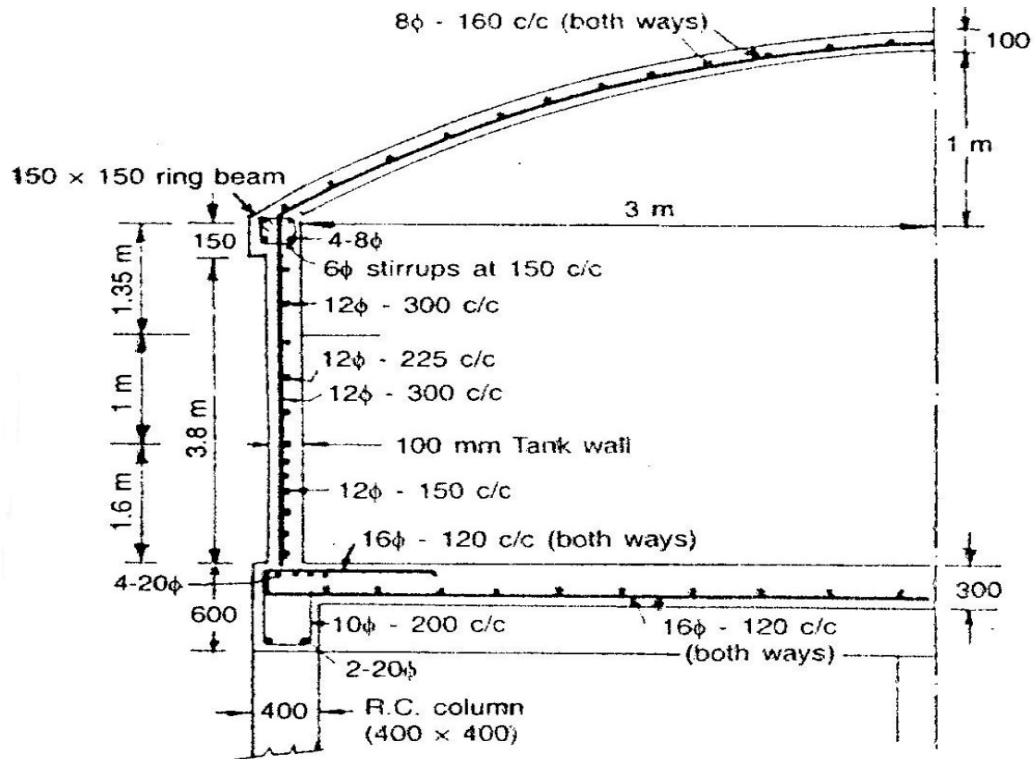

Reinforcement details in dome, tank walls and ring girder.

Since $\tau_v > \tau_c$, shear reinforcements are required.

$$\text{Balance shear} = [182.5 - (0.3 \times 500 \times 500)/1000] \\ = 107.5 \text{ kN}$$

Using 10 mm diameter, 2-legged stirrups spacing :

$$s_v = \left(\frac{230 \times 2 \times 78.5 \times 500}{107.5 \times 10^3} \right) = 167 \text{ mm}$$

Adopt a spacing of 160 mm centres.

Steel required for mid span section is :

$$A_{st} = \left(\frac{50 \times 10^6}{230 \times 0.9 \times 500} \right) = 484 \text{ mm}^2$$

$$\text{But minimum steel} = \left(\frac{0.85 \text{ } bd}{f_y} \right) \\ = \left(\frac{0.85 \times 500 \times 500}{415} \right) = 512 \text{ mm}^2$$

| | | |
|--|--|--|
| Subject code : 080100048 |  VSA Educational and Charitable Trust's Group of Institutions, Salem – 636 010 Department of Civil Engineering | Chapter Reference details : |
| Name of the subject : DESIGN OF RC STRUCTURES | | Design of rc elements, Mr. N . krishnaraju |
| Date of deliverance : | | |

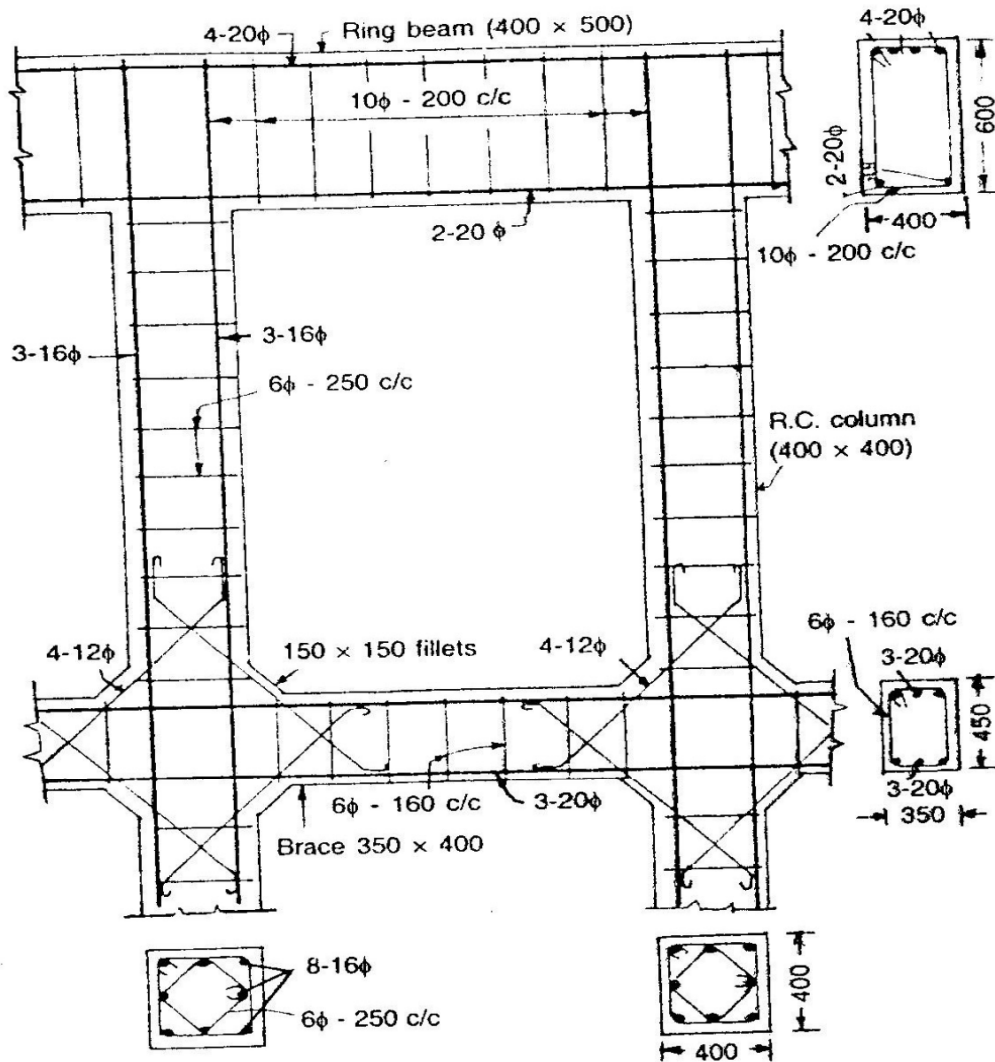

Reinforcement details in ring girder, columns and braces.

Provide 2 bars of 20 mm diameter ($A_{st} = 628 \text{ mm}^2$)

Equivalent shear is obtained as :

$$\begin{aligned}
 V_c &= (V + 1.6 T/b) \\
 &= [105 + 1.6 (10/0.5)] \\
 &= 137 \text{ kN}
 \end{aligned}$$

$$\tau_v = \left(\frac{137 \times 10^3}{500 \times 500} \right) = 0.548 \text{ N/mm}^2$$

$$\left(\frac{100 A_{st}}{bd} \right) = \left(\frac{100 \times 628}{500 \times 500} \right) = 0.25$$

| | | |
|--|--|--|
| Subject code : 080100048 |  VSA Educational and Charitable Trust's Group of Institutions, Salem – 636 010 Department of Civil Engineering | Chapter Reference details : |
| Name of the subject : DESIGN OF RC STRUCTURES | | Design of rc elements, Mr. N . krishnaraju |
| Date of deliverance : | | |

From Table 23 of IS : 456 code, $\tau_c = 0.22 \text{ N/mm}^2$

Since $\tau_v > \tau_c$, shear reinforcements are required

$$\begin{aligned} \text{Balance shear} &= [137 - (0.22 \times 500 \times 500)/1000] \\ &= 82 \text{ kN} \end{aligned}$$

Using 10 mm diameter – 2 legged stirrups, the spacing is given by :

$$s_v = \left(\frac{230 \times 2 \times 78.5 \times 500}{12 \times 10^3} \right) = 220 \text{ mm}$$

(b) *Raft slab*

Maximum projection of raft slab from the face of column = 500 mm

$$\text{Soil pressure} = \left(\frac{2190}{\pi \times 6.1 \times 1.5} \right) = 76 \text{ kN/m}^2$$

Considering 1 m width of slab along the circular arc :

$$\text{Maximum } B.M. = \left(\frac{76 \times 0.5^2}{2} \right) = 9.5 \text{ kN.m}$$

$$\text{Effective depth} = d = \sqrt{\frac{9.5 \times 10^6}{0.897 \times 1000}} = 103 \text{ mm}$$

Adopt $d = 120 \text{ mm}$ and an overall depth = 150 mm

$$A_{st} = \left(\frac{9.5 \times 10^6}{230 \times 0.9 \times 120} \right) = 382 \text{ mm}^2$$

Provide 12 mm diameter bars at 200 mm centres ($A_{st} = 565 \text{ mm}^2$)

$$\text{Distribution steel} = \left(\frac{0.12 \times 1000 \times 150}{100} \right) = 180 \text{ mm}^2$$

Provide 6 mm diameter bars at 150 mm centres ($A_{st} = 217 \text{ mm}^2$)

Maximum shear force in raft slab at a distance of 120 mm from face of girder
= $(76 \times 0.38 \times 1) = 28.88 \text{ kN}$

$$\tau_v = \left(\frac{28.88 \times 10^3}{1000 \times 320} \right) = 0.09 \text{ N/mm}^2$$

$$\left(\frac{100 A_{st}}{b.d} \right) = \left(\frac{100 \times 565}{1000 \times 120} \right) = 0.47$$

| | | |
|--|--|--|
| Subject code : 080100048 |  VSA Educational and Charitable Trust's Group of Institutions, Salem – 636 010 Department of Civil Engineering | Chapter Reference details : |
| Name of the subject : DESIGN OF RC STRUCTURES | | Design of rc elements, Mr. N . krishnaraju |
| Date of deliverance : | | |

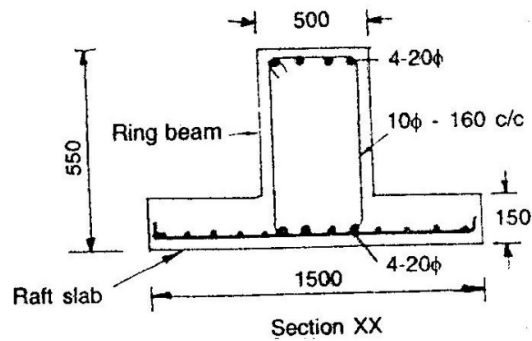
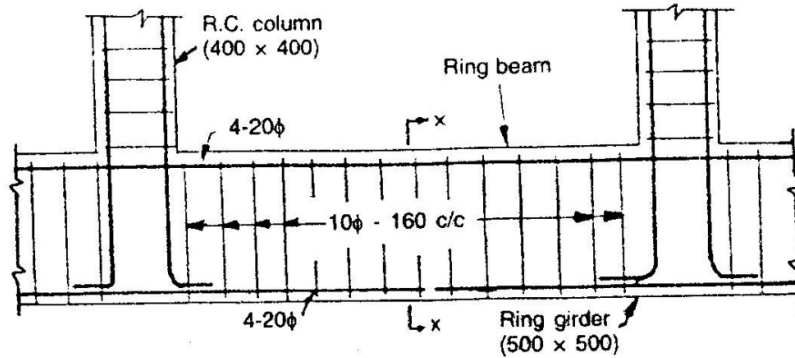

Reinforcement details in ring beam and raft slab.

From Table 23 of IS : 456 Code, $k_s \cdot \tau_c = (1.30 \times 0.28)$
 $= 0.364 \text{ N/mm}^2 > \tau_v$

Hence shear stresses in the slab are within safe permissible limits.

| | | |
|--|--|--|
| Subject code : 080100048 |  VSA Educational and Charitable Trust's Group of Institutions, Salem – 636 010 Department of Civil Engineering | Chapter Reference details : |
| Name of the subject : DESIGN OF RC STRUCTURES | | Design of rc elements, Mr. N . krishnaraju |
| Date of deliverance : | | |

Domes

Design example

A reinforced concrete dome of 6 m base diameter with a rise of 1.25 m is to be designed for a tank. The uniformly distributed live load including finishes on dome may be taken as 2 kN/m². Adopting M-20 concrete and Grade-I steel, design the dome and ring beam. Permissible stress in steel = 100 N/mm².

1. Data

Base diameter $D = 6$ m
Rise of dome = 1.25 m
Live load on dome = 2 kN/m²

2. Permissible stresses

$\sigma_{st} = 100$ N/mm²
Tensile stress in concrete = 2.8 N/mm² for M-20 concrete
 $\sigma_{cc} = 5$ N/mm², $m = 13$

3. Dimensions of dome

If R = Radius of the dome

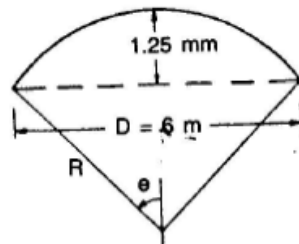

Dimensions of dome

$$(R - 1.25)^2 = R^2 - 3^2 \quad \therefore R = 4.23 \text{ m}$$

$$\therefore \sin \theta = \left(\frac{3}{4.23} \right) = 0.7092 \quad \cos \theta = 0.7049$$

Assume thickness of dome $t = 100$ mm

| | | |
|--|--|--|
| Subject code : 080100048 |  VSA Educational and Charitable Trust's Group of Institutions, Salem – 636 010 Department of Civil Engineering | Chapter Reference details : |
| Name of the subject : DESIGN OF RC STRUCTURES | | Design of rc elements, Mr. N . krishnaraju |
| Date of deliverance : | | |

4. Loads

$$\begin{aligned} \text{Self weight of dome} &= (0.1 \times 24) = 2.4 \text{ kN/m}^2 \\ \text{Live load and finishes} &= 2.0 \text{ kN/m}^2 \\ \text{Total load } w &= 4.4 \text{ kN/m}^2 \end{aligned}$$

5. Stresses in dome

$$\text{Meridional thrust } T_1 = \left(\frac{wR}{1 + \cos \theta} \right) = \left(\frac{4.4 \times 4.23}{1 + 0.7049} \right) = 10.91 \text{ kN/m}$$

$$\therefore \text{Meridional compressive stress} = \left(\frac{10.91 \times 10^3}{1000 \times 10} \right) = 1.091 \text{ N/mm}^2$$

$$\begin{aligned} \text{Hoop stress} &= \frac{wR}{t} \left[\cos \theta - \frac{1}{1 + \cos \theta} \right] = \left(\frac{4.4 \times 4.23}{0.1} \right) \left[0.7049 - \frac{1}{1.7049} \right] \\ &= 22 \text{ kN/m}^2 = 0.022 \text{ N/mm}^2 \end{aligned}$$

6. Reinforcement

Since the stresses are very low, nominal reinforcement of 0.3% of cross-sectional area is provided.

$$\therefore A_{st} = \left(\frac{0.3}{100} \times 1000 \times 100 \right) = 300 \text{ mm}^2$$

$$\text{Spacing of 8 mm diameter bars} = \left(\frac{1000 \times 50}{300} \right) = 166 \text{ mm}$$

Adopt 8 mm diameter bars at 160 mm centres both meridionally and circumferentially.

7. Ring beam

$$\text{Horizontal component of } T_1 = T_1 \cos \theta = (10.91 \times 0.7049) = 7.69 \text{ kN/m}$$

$$\text{Hoop tension in ring beam} = \left(\frac{7.69 \times 6}{2} \right) = 23.07 \text{ kN}$$

$$A_s = \left(\frac{23.07 \times 10^3}{100} \right) = 230.7 \text{ mm}^2$$

| | | |
|--|--|--|
| Subject code : 080100048 |  VSA Educational and Charitable Trust's Group of Institutions, Salem – 636 010 Department of Civil Engineering | Chapter Reference details : |
| Name of the subject : DESIGN OF RC STRUCTURES | | Design of rc elements, Mr. N . krishnaraju |
| Date of deliverance : | | |

Provide 4 bars of 10 mm diameter ($A_s = 314 \text{ mm}^2$)

If A_c = cross-sectional area of ring beam, equivalent area of concrete = $(A_c + m \cdot A_{st})$. Allowing a tensile stress of 2.8 N/mm^2

$$\left[\frac{F_t}{A_c + m A_{st}} \right] = 2.8 \quad \therefore \left[\frac{23.07 \times 10^3}{A_c + (13 \times 314)} \right] = 2.8$$

$$\therefore A_c = 4158 \text{ mm}^2$$

Area required is very small. However provide a ring beam of size $150 \text{ mm} \times 150 \text{ mm}$. With 4 bars of 10 mm diameter as hoop steel and stirrups of 6 mm diameter at 150 mm centres

Important Definition

DOMES

The domes consist of a shell which is governed by the revolution of a geometrical curve about an axis.

MERIDIONAL THRUST:

The load applied on the dome it gets resisted by the horizontal rings. There will be a thrust of one ring on the other. This thrust is called the meridional thrust.

HOOP STRESS:

It is the thrust per unit run on the ring.

RING BEAM:

The horizontal component of the meridional thrust at the base will induce an outward push of the cylindrical wall carrying dome. In order to prevent this ring beam is provided at the base of the dome.

INTZE TANK:

If a domed floor is provided the ring girder supported on the columns will be relieved from the horizontal thrust. This is possible because the horizontal thrust of the conical slab and the domed floor will balance. Such a tank is called an intze tank.

CYLINDRICAL WALL:

This will be designed for hoop tension caused by horizontal water pressure.

RING GIRDER:

This will be designed to support the tank and its contents. The girder will be supported on the columns.