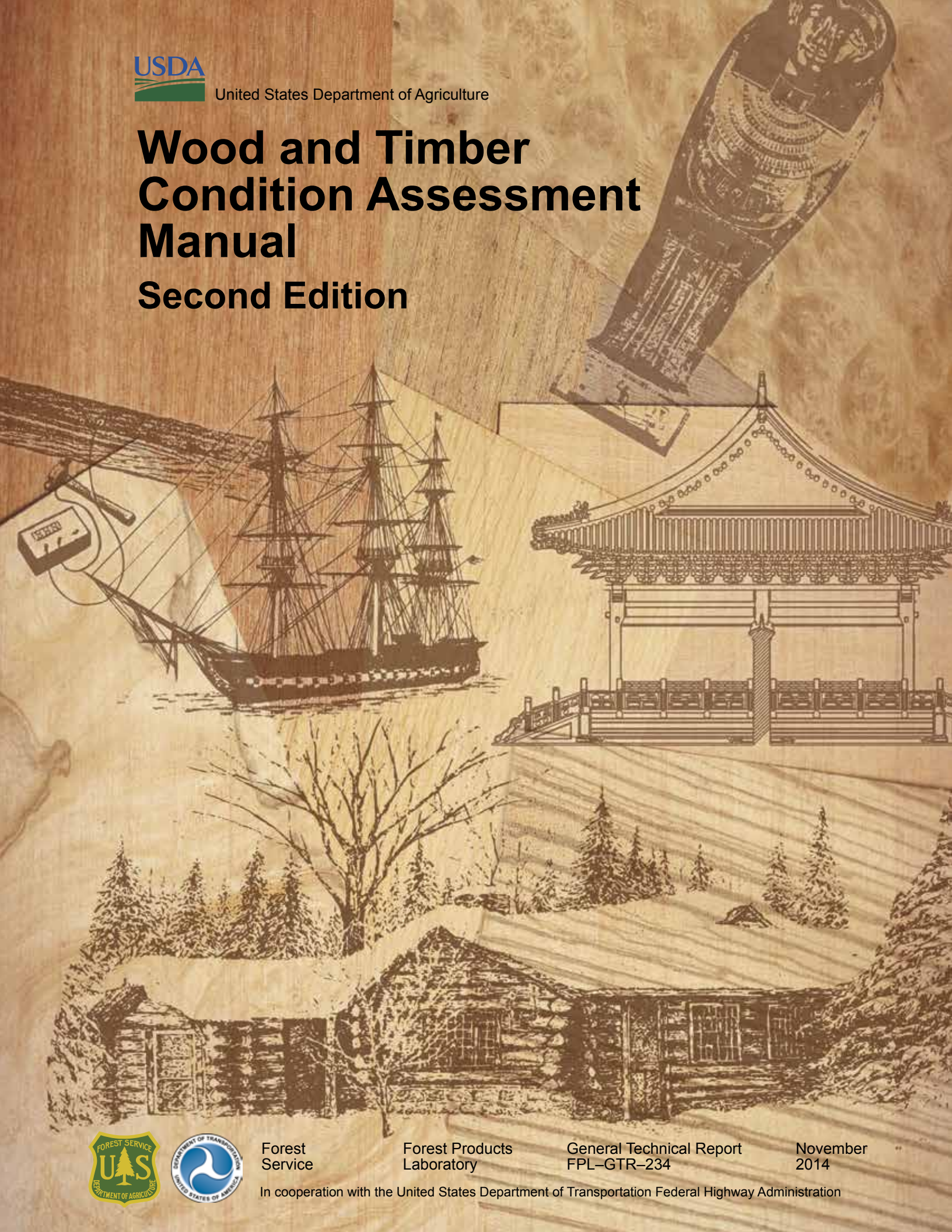




United States Department of Agriculture

# Wood and Timber Condition Assessment Manual Second Edition



Forest Service

Forest Products Laboratory

General Technical Report  
FPL-GTR-234

November  
2014

In cooperation with the United States Department of Transportation Federal Highway Administration

## Abstract

This report summarizes information on condition assessment of in-service wood, including visual inspection of wood and timbers, use of ultrasound and probing/boring techniques for inspection, and assessment of wood and timbers that have been exposed to fire. The report also includes information on assigning allowable design values for in-service wood.

Keywords: Wood, timbers, condition assessment, visual, coring, probing, ultrasound, post-fire assessment

November 2014 [Corrected April 2016 (pages 47 and 73)]

---

White, Robert H.; Ross, Robert J. (Eds.). 2014. Wood and timber condition assessment manual: second edition. General Technical Report FPL-GTR-234. Madison, WI: U.S. Department of Agriculture, Forest Service, Forest Products Laboratory. 93 p.

A limited number of free copies of this publication are available to the public from the Forest Products Laboratory, One Gifford Pinchot Drive, Madison, WI 53726-2398. This publication is also available online at [www.fpl.fs.fed.us](http://www.fpl.fs.fed.us). Laboratory publications are sent to hundreds of libraries in the United States and elsewhere.

The Forest Products Laboratory is maintained in cooperation with the University of Wisconsin.

The use of trade or firm names in this publication is for reader information and does not imply endorsement by the United States Department of Agriculture (USDA) of any product or service.

The USDA prohibits discrimination in all its programs and activities on the basis of race, color, national origin, age, disability, and where applicable, sex, marital status, familial status, parental status, religion, sexual orientation, genetic information, political beliefs, reprisal, or because all or a part of an individual's income is derived from any public assistance program. (Not all prohibited bases apply to all programs.) Persons with disabilities who require alternative means for communication of program information (Braille, large print, audiotape, etc.) should contact USDA's TARGET Center at (202) 720-2600 (voice and TDD). To file a complaint of discrimination, write to USDA, Director, Office of Civil Rights, 1400 Independence Avenue, S.W., Washington, D.C. 20250-9410, or call (800) 795-3272 (voice) or (202) 720-6382 (TDD). USDA is an equal opportunity provider and employer.

# **Wood and Timber Condition Assessment Manual**

## **Second Edition**

Edited by

Robert H. White

Robert J. Ross



Forest Products  
Laboratory

## Contents

<i>Foreword</i> .....	<i>iii</i>
<i>Preface</i> .....	<i>v</i>
Chapter 1—Visual Inspection .....	1
Chapter 2—Sounding, Probing, Moisture Content, and Resistance Drilling Techniques .....	5
Chapter 3—Inspection of Timber Structures Using Stress Wave Timing Nondestructive Evaluation Tools .....	13
Chapter 4—New Techniques and Technologies .....	23
Chapter 5—Post-Fire Assessment of Structural Wood Members .....	33
Chapter 6—Estimation of Design Values for In-Service Wood .....	45
Chapter 7—Condition Assessment Report .....	77
Chapter 8—Summaries from Actual Inspections .....	83

## Foreword

Since it was first published in 2004, the *Wood and Timber Condition Assessment Manual* has become an extremely valuable resource for wood design professionals. Dr. Robert Ross and his team continue to be leading experts in this field and are the “go-to source” for information regarding condition assessment. To my knowledge, there is no other source for the type of information found here.

This update from the first edition contains significant new information, including the latest assessment techniques and technology and a new chapter on estimation of allowable properties for in-service wood. Other chapters were updated, and example assessment and summary reports remain as practical resources.

Many thanks to Dr. Ross and his team for persisting with this topic and providing valuable tools and guidance.

*John “Buddy” Showalter, P.E.  
Vice President, Technology Transfer  
American Wood Council*



## Preface

Deterioration of an in-service wood member may result from a variety of causes during the life of a structure. Periodic inspection of wood used in structures is important for determining the extent of deterioration so that degraded members may be replaced or repaired to avoid structural failure.

Inspection professionals use a wide variety of techniques to assess the condition of wood in service. Visual, mechanical probing, and stress wave or ultrasound-based techniques are all used either individually or in combination by inspectors. Although these techniques are based on solid technical information and supporting research, prior to publication of the *Wood and Timber Condition Assessment Manual* in 2004, no practical, comprehensive manual provided information on inspection of wood in service.

The *Wood and Condition Assessment Manual* was prepared to address this need. The manual was prepared from numerous research studies, inspections, and lectures dealing with assessing the condition of in-service wood and timber. It was intended for inspection professionals. A concerted effort was made to provide clear and concise explanations of various aspects of inspecting in-service wood and timber. To this end, a number of photographs and drawings obtained from actual inspections were included.

The 2004 *Wood and Timber Condition Assessment Manual* proved to be a widely used reference document and a primary technical source for inspection professionals worldwide. User feedback included many positive comments about description of the various inspection tools available and post-fire assessment of structural wood members. Users did express a strong desire to have information on the estimation of allowable design values for in-service wood in future editions.

We relied heavily on this feedback in preparation of the *Wood and Timber Condition Assessment Manual—Second Edition*. It is organized into eight chapters. Chapters 1 to 3 present background information on techniques currently used by inspectors, including information on visual inspection techniques, mechanical coring or probing techniques, and stress wave or ultrasound-based techniques. Included in each chapter is a detailed description of the technique, a list of currently available tools and where they can be obtained, and guidelines for their use. Each chapter concludes with a list of references that serve as the technical base for the technique. Chapter 4 is devoted to a review of techniques currently under development for inspection of wood structures. Chapter 5 covers the topic of inspection of fire-damaged wood. A procedure for estimating allowable design values for in-service wood is included in Chapter 6. Chapter 7 is a sample condition assessment report. Summaries of several inspections are included in Chapter 8.

In preparing this second edition of the *Wood and Timber Condition Assessment Manual*, I had three objectives: (1) to update the existing chapters to reflect advancements in inspection methods; (2) to develop new material that focuses on a wide range of new techniques and technologies that have been investigated for use in assessing the condition of wood structures

and provide estimates of the properties of in-service wood; and (3) to make the manual available in digital format.

I worked with several well-respected technical authorities in preparing this edition. The original chapters on visual inspection, drilling/coring/probing techniques, and stress wave timing techniques (Chapters 1–3) were reviewed and revised slightly. The chapter on post-fire assessment of structural members (Chapter 5) was modified significantly to add new material on the use of nondestructive testing techniques. Because of repeated requests from field professionals, a new chapter (Chapter 6) was developed that addresses estimation of allowable properties for in-service wood.

I thank the technical contributors to this edition of the manual:

Brian K. Brashaw, PhD, Program Director, Wood Materials & Manufacturing, University of Minnesota Duluth;

Zhiyong Cai, PhD, P.E., Supervisory Research Materials Engineer, USDA Forest Products Laboratory;

David E. Kretschmann, P.E., Research General Engineer, USDA Forest Products Laboratory;

Xiping Wang, PhD, Research Forest Products Technologist, USDA Forest Products Laboratory;

Brian Kukay, PhD, P.E., Associate Professor, General Engineering, Montana Tech.

I also acknowledge Professor (retired) Roy F. Pellerin, Washington State University, for his valuable contributions to the first edition of the manual. Special thanks to Greg Fehr, P.E., Adam Senalik, P.E., and Tom Williamson, P.E., for their technical reviews.

I acknowledge the following for the excellent artwork on the cover—Beijing Research Institute of Architectural Heritage; Judy Hesterberg, Hancock, Michigan; and Tivoli Gough, USDA Forest Products Laboratory.

Financial support for this second edition of *Wood and Timber Condition Assessment Manual* from the USDA Forest Service is gratefully acknowledged.

This edition of the *Wood and Timber Condition Assessment Manual* is dedicated to my good friend and colleague, Dr. Robert Hawthorne White, Research Wood Scientist, USDA Forest Products Laboratory. Robert was an internationally recognized leader in the wood science profession, where he conducted research on fire performance issues with wood products. He was very active in ASTM International—and was recognized by ASTM at its highest levels. Robert was a well-respected scientist, worldwide, and he served the public in a professional manner for nearly 40 years. His reputation is impeccable, and his voice still carries much weight in the building codes and international standards arenas.

The *Wood and Timber Condition Assessment Manual—Second Edition* is available in digital format from the USDA Forest Service Forest Products Laboratory website.

*Robert J. Ross*





## Visual Inspection

Robert J. Ross

The simplest method for locating deterioration is visual inspection—observing the structure for signs of actual or potential deterioration, noting areas that require further investigation. When assessing the condition of a structure, visual inspection may be the sole method used. For example, substantial modifications of structurals are easily identified visually. Visual inspection requires strong light and is useful for detecting intermediate or advanced surface decay, water damage, mechanical damage, or failed members. Visual inspection cannot detect early stage decay, when remedial treatment is most effective. During an inspection, the following signs of deterioration should be investigated.

### Fruiting Bodies

Although they do not indicate the amount or extent of decay, fruiting bodies provide a positive indication of fungal attack. Some fungi produce fruiting bodies after small amounts of decay have occurred; others develop only after decay is extensive. When fruiting bodies are present, they indicate the possibility of a serious decay problem.

Figures 1.1 and 1.2 show fruiting bodies that were observed during inspection of Washington State University’s football stadium. Figure 1.2 shows the extent of deterioration inside the beam. Note that in Figure 1.1, the fruiting body is located where two timber beams (placed end-to-end) rest on a column. Exposed end grain allows for moisture accumulation and subsequent absorption by the timbers. Figure 1.3 illustrates the potential extent of deterioration in both beams.

### Sunken Faces or Localized Collapse

Sunken faces or localized surface depressions can indicate underlying decay. Decay voids or pockets may develop close to the surface of the member, leaving a thin, depressed layer of intact or partially intact wood at the surface. Crushed wood can also be an indicator of decay.

Figure 1.4 shows a timber beam that failed in bearing (compression perpendicular to grain). Such collapse indicates that the inner portion of the timber is severely deteriorated. Figure 1.5 illustrates that when the inner portion of the timber is severely deteriorated, the outer shell can collapse when the timber is stressed in bearing.



Figure 1.1—Fruiting body between two beams.



Figure 1.2—Fruiting bodies can indicate extensive damage inside the beam.

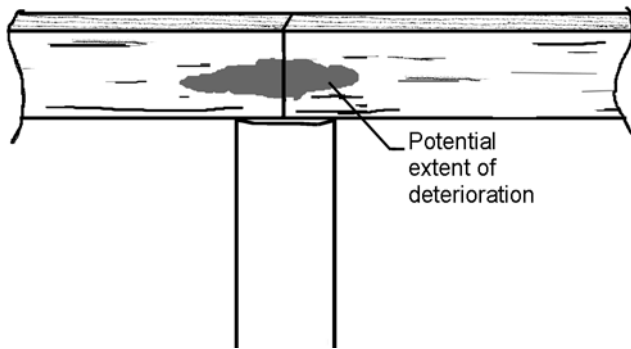


Figure 1.3—Potential deterioration in both beams.

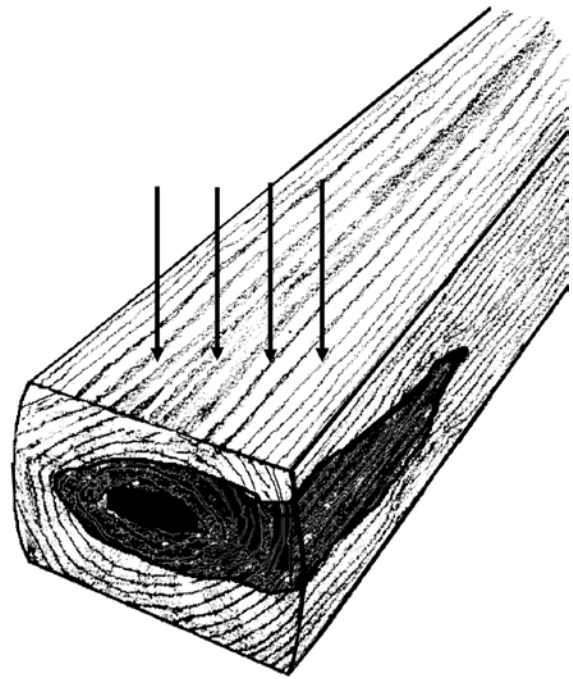


Figure 1.5—Because of interior deterioration, the outer shell can collapse when the timber is stressed in bearing.



Figure 1.4—The timber beam's outer shell buckled as a result of interior deterioration.

## Staining or Discoloration

Staining or discoloration of wood indicates that it has been subjected to water and potentially has a high moisture content suitable to support decay. Rust stains from connection hardware also are a good indication of wetting.

Inspection of the Red Cliff Recreation Hall near Bayfield, Wisconsin, revealed severe staining and discoloration of the fiberboard product used in the ceiling (Figs. 1.6 and 1.7). Discoloration and mold indicated that the structure had been exposed to moisture and the wood could possibly be deteriorated. Removal of several ceiling panels revealed that the fiberglass insulation above them was saturated with water (Fig. 1.8). This moisture provided an ideal environment for the growth of mold and decay fungi. As a consequence of



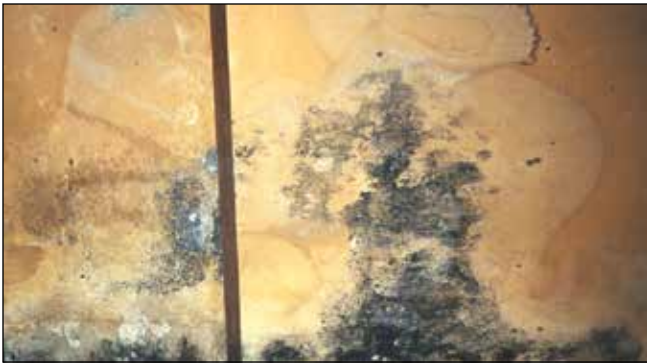
Figure 1.6—The ceiling panels were stained and discolored.

this moisture exposure, wood members in the roof and walls also contained areas of deterioration (Fig. 1.9).

## Insect Activity

Insect activity is visually characterized by holes, frass, and powder posting. The presence of insects may also indicate the presence of decay.

Figure 1.10 is a piling from a bridge. Initially deteriorated by decay, carpenter ants were attracted to the softened wood and continued to destroy the piling. Once the flashing was removed, the severe deterioration could be readily observed.



**Figure 1.7**—Close-up of the severely stained and discolored ceiling panels.



**Figure 1.8**—Removing the ceiling panels revealed that the fiberglass insulation was saturated with water.



**Figure 1.9**—As a consequence of the moisture exposure, wood members in the roof and walls also contained areas of deterioration.



**Figure 1.10**—Damage to a bridge piling.



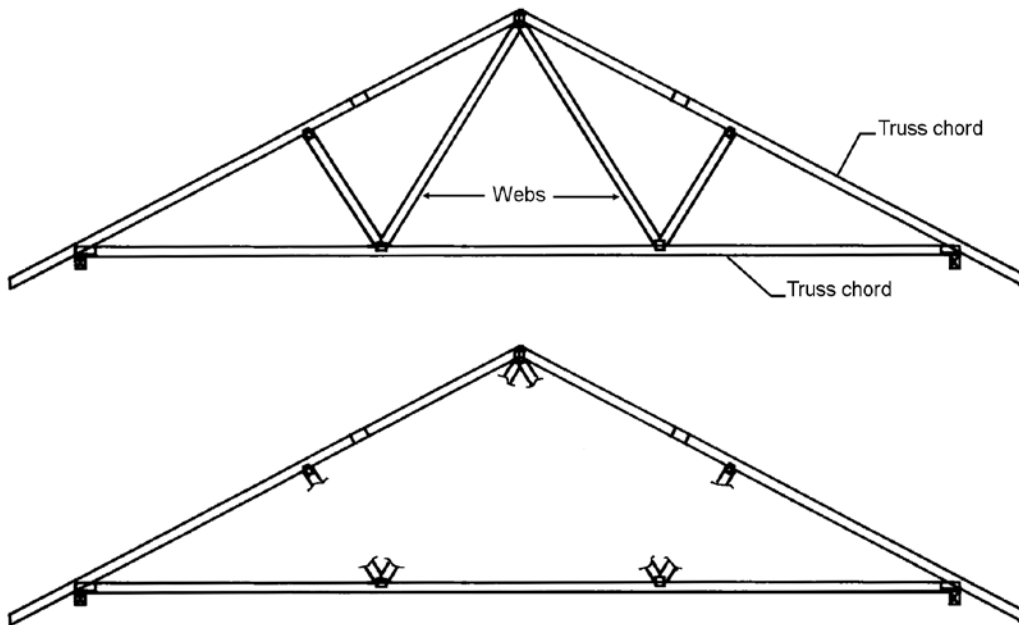
**Figure 1.11**—Metal plate connectors were cut and bent so that the webs could be removed. This should never be done.

## Plant or Moss Growth

Plant or moss growth in splits and cracks, or soil accumulation on the structure, indicates that adjacent wood has been at a relatively high moisture content for a sustained period and may sustain growth of decay fungi.

## Missing Members

Frequently, it is observed that entire structural members have been removed. Figures 1.11 and 1.12 show an in-service wood truss that had its webs removed by the homeowner with the intent of creating living space in the attic.



**Figure 1.12**—The homeowner removed the webs from the truss leaving only the chords to support the roof. This should never be done.



**Figure 1.13**—Only the outer portion of this timber contains preservatives.

This should *never* be done and *must* be noted in any inspection report. Any change to web or chord members *must* be reported.

### Check and Splits

Checks and splits in members can indicate a weakened member. Checks vary in depth; splits extend through the entire cross section. The large timber shown in Figure 1.13 was treated with preservatives. Note that only the outer portion of the timber contains preservatives. Depth of preservative treatment depends on species of wood and characteristics of treatment. If a check or split develops in the timber that is of sufficient depth, the inner untreated wood is susceptible to moisture and decay fungi.

### Alterations

Alterations can weaken members. Figure 1.14 shows a floor joist found during an inspection of the Red Cliff Recreation Hall. A section of the bottom, or tension, side of the joist was removed to facilitate plumbing. This type of modification can severely weaken the joist. This should *never* be done and *must* be noted in any inspection report.



**Figure 1.14**—A floor joist was cut to make room for plumbing. This should never be done.

## Sounding, Probing, Moisture Content, and Resistance Drilling Techniques

Brian Brashaw

Simple mechanical tests are frequently used for in-service inspection of wood elements in timber structures. For example, hammer sounding and probing are used in combination with visual inspection to conduct an initial assessment of the condition of a member. The underlying premise for such tests is that degraded wood is relatively soft and might sound hollow, with low resistance to penetration.

### Sounding and Probing

One of the most commonly used techniques for detecting deterioration is to hit the surface of a member with a hammer or other object. Based on the sound quality or surface condition, an inspector can identify areas of concern for further investigation using advanced tools like a stress wave timer or resistance microdrill. Deteriorated areas typically have a hollow or dull sound that may indicate internal decay. A pick hammer commonly used by geologists is recommended for use in timber structures because it allows inspectors to combine the use of sound and the pick end to probe the element (Fig. 2.1).

Probing with a moderately pointed tool, such as an awl or knife, locates decay near the wood surface as indicated by excessive softness or a lack of resistance to probe penetration and the breakage pattern of the splinters. A brash, or brittle break indicates decayed wood, whereas a splintered break indicates sound wood. Although probing is a simple inspection method, experience is required to interpret results. Care must be taken to differentiate between decay and water-softened wood, which may be sound but somewhat softer than dry wood. Assessing damage in soft-textured woods, such as western redcedar, is sometimes difficult. Figure 2.2 shows an awl probe inserted into a split to assess decay that is visible on the railing end.

Probes can also be used to assess the depth of splits and checks in timber members. Flat bladed probes, such as pocket knives or feeler gauges, are recommended for use in this process. This is also important to understanding the effect of checks and cracks in other advanced techniques such as stress wave inspection. Figure 2.3 shows the use of probes to assess the depth of checks and cracks in timber bridge elements.



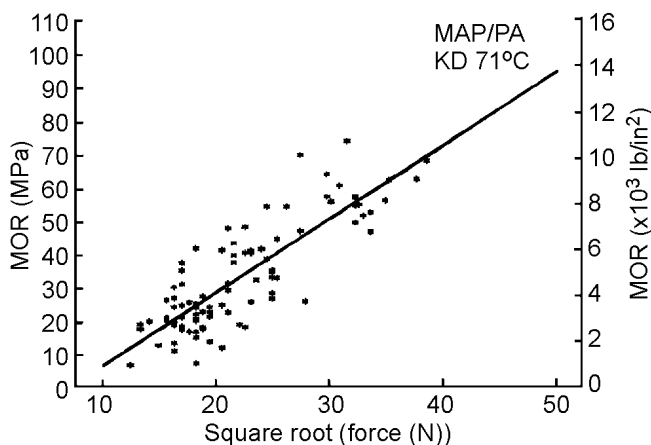
Figure 2.1—A hammer pick is an effective tool for initial assessments of timber bridge elements.



Figure 2.2—An awl is used to assess depth and presence of decay in a horizontal split.



**Figure 2.3—Probes are used to assess depth of cracks, checks, and through splits in timber bridge elements.**



**Figure 2.4—Relationship between withdrawal resistance and residual strength. MOR, modulus of rupture.**

Screw withdrawal testing has been used as an indicator of biological deterioration in timber members. Additional research has correlated screw withdrawal resistance to physical and mechanical properties such as density, modulus of elasticity, modulus of rupture, and shear modulus. These tests are typically conducted by extracting a screw inserted at an angle perpendicular to the surface of the timber specimen. Although these tests are dependent on local material condition, information from both deteriorated and good material locations can be helpful during wood structure evaluations.

A quantitative test based on the premise that underlies mechanical probing tests (relative softness of degraded wood and consequent low resistance to probe penetration)

was developed by Talbot (1982). His test differed from the probing-type test in that instead of evaluating penetration resistance of a probe, it examined withdrawal resistance of a threaded probe, similar to a wood screw, inserted into a member. Talbot believed that a correlative relationship between withdrawal resistance and residual strength should exist and would be relatively easy to determine. He conducted an experiment using several small Douglas-fir beams in various stages of degradation as a result of exposure to decay fungi. Prior to testing the wood to failure in bending, probe withdrawal resistance was measured at the neutral axis of the beams. Bending strength and corresponding probe resistance values were then compared. The results revealed a relationship between withdrawal resistance and residual strength (Fig. 2.4). Talbot used this test in conjunction with stress wave techniques (described in detail in Chapter 3) to assess the extent of damage to solid-sawn timbers in the football stadium at Washington State University.

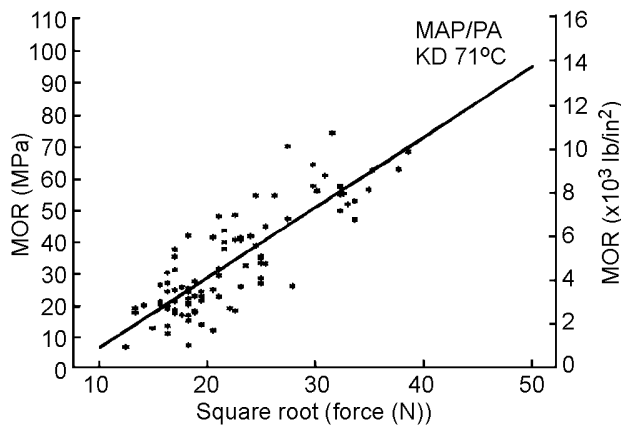
A modification to Talbot's technique was developed for use in evaluating in-service strength of fire-retardant-treated (FRT) plywood in the early 1990s. A portable screw withdrawal system was utilized to inspect FRT plywood and identify substantial degrade. An extensive research effort was devoted to the use of Talbot's test for assessing residual strength of in-service panel products treated with fire retardant. Winandy et al. (1998) designed and conducted tests on a large sample of plywood specimens that were treated with fire-retardant chemicals and subsequently exposed to elevated temperatures. Screw withdrawal loads were determined for each specimen prior to static bending tests. Correlative relationships were then established between screw withdrawal strength and static bending properties (Fig. 2.5).

Recent evaluations have been completed by other researchers and commercial companies (Cai et al. 2002, Fakopp 2014). Figure 2.6 shows one commercial screw withdrawal resistance unit.

## Moisture Content Inspection

Moisture meters can be used effectively in inspecting timber elements. The presence of moisture is required for decay to occur in timber. Typically, moisture conditions in timber of less than 20% will not allow decay to occur; as moisture increases above 20%, the potential for decay to occur increases.

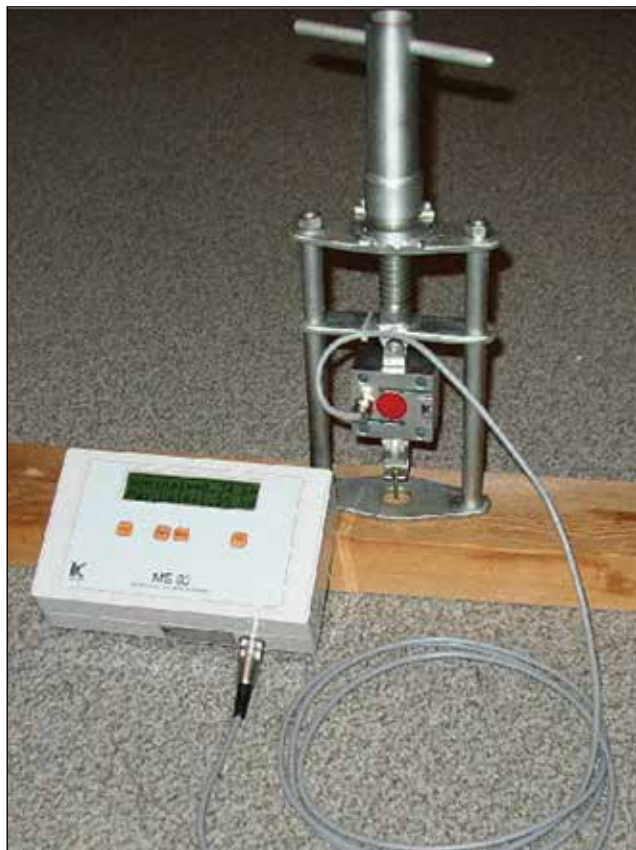
Serious decay occurs only when the moisture content of the wood is above 30%. This occurs when dry wood is exposed to direct wetting through rain, moisture infiltration, or contact with ground water or bodies of water. Wood decay fungi will not affect wood that is fully saturated with water and without oxygen. Timber members (such as bridge piling) should be carefully inspected near the water line because rivers and streams have varying water levels throughout the year and from year to year. Figure 2.7 shows the use of moisture meters with long insulated pins (up to 3 in.



**Figure 2.5—Relationship of screw-withdrawal force to bending strength for 12-mm- (1/2-in.-) thick plywood. MAP, mono-ammonium phosphate; PA, phosphoric acid; KD, dry-kiln drying temperature; and MOR, modulus of rupture.**



**Figure 2.7—A pin-style moisture meter is used to determine moisture content of timber elements.**



**Figure 2.6—Screw withdrawal resistance meter that can be used to assess local wood quality.**

(75 mm) long) to assess moisture content of timber abutment caps. Pin-style moisture meters measure electrical resistance between two metal pins that are driven into the member and use this measurement to determine moisture content.

## Drilling

Drilling and coring are the most common methods used to detect internal deterioration in wood members. Both techniques are used to detect the presence of voids and to determine the thickness of the residual shell when voids are present. Drilling utilizes an electric power drill or hand-crank drill equipped with a 9.5- to 19-mm- (3/8- to 3/4-in.-) diameter bit. Power drilling is faster, but hand drilling allows the inspector to monitor drilling resistance and may be more beneficial in detecting pockets of deterioration. In general, the inspector drills into the member in question, noting zones where drilling becomes easier and observing drill shavings for evidence of decay. The presence of common wood defects, such as knots, resin pockets, and abnormal grain, should be anticipated while drilling and should not be confused with decay. If decay is detected, remedial treatments, such as copper naphthenate, can be added to the wood through the inspection hole to help retard further decay. The inspection hole is probed with a bent wire or a thickness gauge to measure shell thickness. Because these holes are typically 3/8 to 3/4 in. diameter, they should be filled with a wood dowel section that has been soaked in a preservative.

## Coring

Coring with an increment borer (often used for determining the age of a tree) also provides information on the presence of decay pockets and other voids. The resultant solid wood core can be carefully examined for evidence of decay. In addition, the core can be used to obtain an accurate measure of the depth of preservative penetration and retention. Figure 2.8 shows an increment core tool and the extracted core. The core can also be used to determine the wood spe-



**Figure 2.8—An increment core can be used to conduct inspections of timber bridge elements. This image shows an extracted core from an in-service timber pile ready for examination.**

cies. To prevent moisture and insect entry, a bored-out core hole should be filled with a wood plug treated with copper naphthenate.

## Resistance Drilling

Another commercially developed drilling technique is the resistance drill system. Developed in the late 1980s, this system was originally developed for use by arborists and tree care professionals to assess tree rings, evaluate the condition of urban trees, and locate voids and decay. This technology is now being utilized to identify and quantify decay, voids, and termite galleries in wood beams, columns, poles, and piles. This technique is now the preferred drilling and coring technique for timber elements. Figure 2.9 shows a resistance microdrill being used to assess the level of decay in a timber bridge pile.

Several machine types are available from different manufacturers. They operate under the same general principle of measuring electrical power consumption of a needle rotation motor. This value is proportional to mechanical torque at the needle and primarily depends on wood density (Rinn 2013). The purpose of the equipment is to identify areas in timber elements that have low density, indicating decay or deterioration.

Resistance drill equipment measures the resistance of wood members to a 0.6-in.- (1.5-mm-) diameter drill bit with a 0.18-in. (3.0-mm) head. This flat tipped drill bit travels through the member at a defined movement rate and generates information that allows an inspector to determine the exact location and extent of any damaged area. Figure 2.10 shows several drill bit ends that are used in resistance drills. Although the unit is usually drilled into a member in a direction perpendicular to the surface, it is also possible to drill into members at an angle (Fig. 2.11).



**Figure 2.9—A resistance microdrill used for inspection of a historic Civilian Conservation Corps log cabin.**

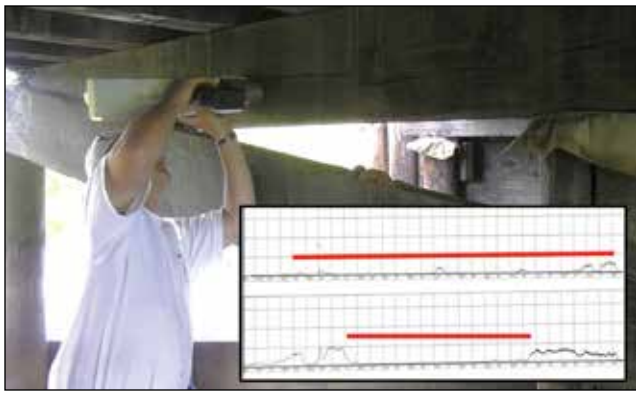


**Figure 2.10—Flat-tipped resistance drill bits used to inspect timber materials.**



**Figure 2.11—Drilling can take place at an angle to assess the area below ground line.**





**Figure 2.12—Resistance microdrilling showing significant decay in the bridge pile cap. The inset shows the paper chart readout from a commercial drilling unit.**



**Figure 2.13—Electronic display on a resistance drill.**



**Figure 2.14—Silicone is used to fill the small drilling hole.**

Resistance drills collect data electronically and can also produce a chart or printout showing relative resistance over the drilling path. Modern tools also promote the ability to view the data on a tablet computer or hand-held mobile phone. Areas of sound wood have various levels of resistance, depending on the density of the species; voids show

no resistance. The inspector can determine areas of low, mild, and high levels of decay with this tool, and quantify the level of decay in the cross section. Figure 2.12 shows a timber abutment cap being assessed with a resistance microdrill and the resulting chart image, which shows minimal drilling resistance and indicates that the majority of the cap is decayed. Figure 2.13 shows a commercial model with an electronic display that allows data to be reviewed in the field and then further processed using a computer in the office. All holes should be filled after drilling, especially if no decay is present. For the microdrill, this can be accomplished by injecting a small amount of silicone sealant or marine adhesive into the small opening (Fig. 2.14).

## Interpreting Drilling Data Charts

Charts or printouts should be reviewed in the field and notes taken to ensure understanding of the testing location. Notes should be taken on a graphical data chart. Care should be exercised to ensure that low density profiles from intact but soft wood (such as conifers) not be misinterpreted as decay. The very center of softwood species near the pith will have low resistance and lack the defined growth rings visible in the outer sections. It is important to understand the type of wood that is being drilled. Sound wood from many hardwood species may have high levels of resistance (over 50%), whereas sound wood from softwood conifers may have low levels of resistance (in the range of 15% to 50+%, depending on its inherent density). It is important to evaluate the levels of decay across the full dimension, as some species have low resistance values but are not decayed. Further, each piece of commercial equipment provides different scales and may indicate different resistance levels. Table 2.1 shows a general assessment rating index that can provide support for the bridge inspector in evaluating resistance data collected during testing. Example electronic drilling charts for a southern yellow pine pile and a Douglas-fir pile cap are shown in Figures 2.15 and 2.16, respectively. Note that while the fundamental concept utilized by these pieces of equipment is essentially the same, data analysis and subsequent display of the data can vary significantly, depending on equipment manufacturer.

**Table 2.1—General assessment of resistance drilling data for Douglas-fir and southern yellow pine bridge members**

Drilling resistance (%)	Decay level	Comments
0	Severe	Decay resulting in an internal void
5–15	Moderate	Often adjacent to the internal void areas
20+	Low to none	Sound material often has resistance that is consistent across the full width

Note: These data must be carefully interpreted because of differences between commercial equipment.

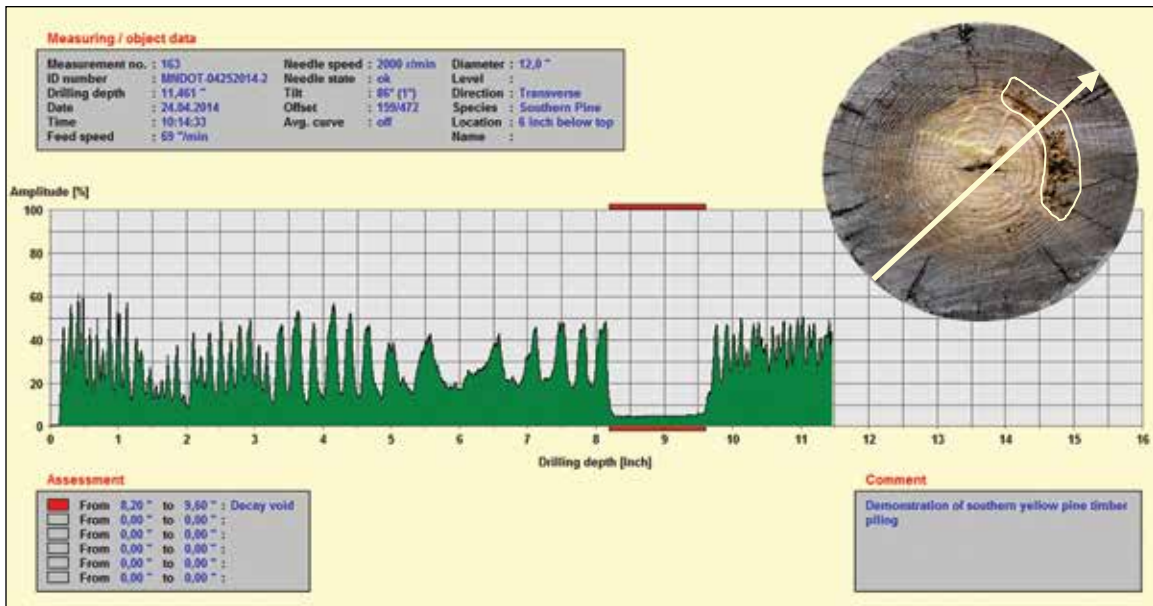


Figure 2.15—Electronic view of a southern yellow pine timber piling showing a decay pocket between 8 and 10 in. of the drilling profile.

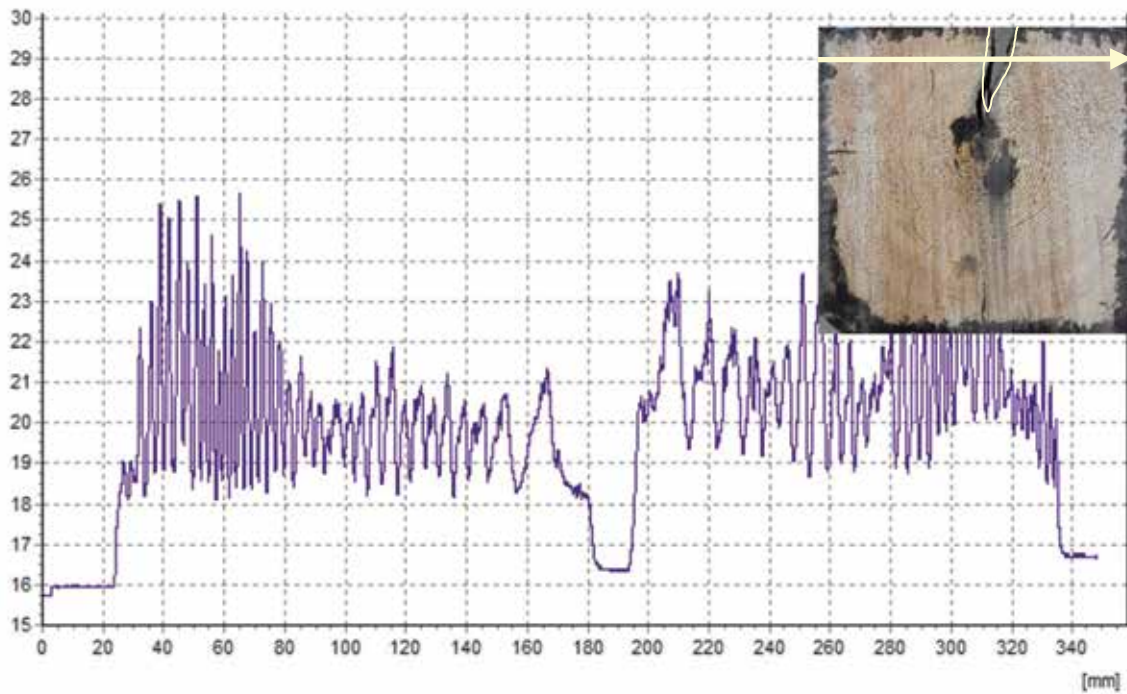


Figure 2.16—Electronic resistance chart of a Douglas-fir pile cap showing a large crack between 180 and 200 mm along the drilling path.

## Commercial Equipment

Several companies produce equipment that is suitable for inspecting timber structures based on these concepts. Additional details for these companies and their equipment follow.

### Increment Borers

Forestry Suppliers Inc.  
Jackson, MS 39284-8397 USA  
Telephone: (800) 647-5368  
Website: [www.forestry-suppliers.com](http://www.forestry-suppliers.com)

Ben Meadows Company  
Janesville, WI USA 53547-5277  
Telephone: (608) 743-8001  
Fax: (608) 743-8007  
Website: [www.benmeadows.com](http://www.benmeadows.com)

### Resistance Microdrills

IML-RESI PD- and F-Series  
IML North America, LLC  
Moultonborough, NH 03254 USA  
Telephone: 603-253-4600  
Website: [www.iml-na.com](http://www.iml-na.com)

Resistograph 4- and 5-Series  
RINNTECH, Inc.  
St. Charles, IL 60174, USA  
Telephone: (630) 377-2477  
Website: [www.rinntech.de](http://www.rinntech.de)

Digital microProbe  
Sibtec Scientific  
Sibert Technology Limited  
2a Merrow Business Centre, Guildford  
Surrey GU4 7WA England  
Telephone: +44 1483 440 724  
Fax: +44 1483 440 727  
Website: [www.sibtec.com](http://www.sibtec.com)

### Screw Withdrawal Resistance Meter

FAKOPP Enterprise  
Agfalva, Hungary  
Telephone: +36 99 33 00 99  
Website: [www.fakopp.com](http://www.fakopp.com)

## References

Cai, Z.; Hunt, M.; Ross, R.J.; Soltis, L.A. 2002. Screw withdrawal—a means to evaluate densities of in-situ wood members. In: Proceedings, 13th international symposium on nondestructive testing of wood. Madison, WI: Forest Products Society: 277–281.

Fakopp. 2014. User's guide: screw withdrawal resistance meter. Agfalva, Hungary: Fakopp Enterprise. [http://www.fakopp.com/site/downloads/Screw\\_Withdrawal.pdf](http://www.fakopp.com/site/downloads/Screw_Withdrawal.pdf). (Accessed April 24, 2014)

Rinn, F. 2013. From damage maps to condition inventories: a proven concept for documentation of results of inspection of timber bridges and other timber structures. International Conference on Timber Bridges. Las Vegas, NV. [http://www.woodcenter.org/docs/ICTB2013/technical/papers/ID\\_139\\_Rinn.pdf](http://www.woodcenter.org/docs/ICTB2013/technical/papers/ID_139_Rinn.pdf)

Talbot, J. 1982. Unpublished research. Pullman, WA: Wood Materials and Engineering Laboratory, Washington State University.

Winandy, J.E.; Lebow, P.K.; Nelson, W. 1998. Predicting bending strength of fire-retardant-treated plywood from screw withdrawal tests. Res. Pap. FPL-RP-568. Madison, WI: U.S. Department of Agriculture, Forest Service, Forest Products Laboratory.



# Inspection of Timber Structures Using Stress Wave Timing Nondestructive Evaluation Tools

Robert J. Ross  
Roy F. Pellerin

The purpose of this chapter is to provide guidelines on the application and use of the stress wave timing inspection method in locating and defining areas of decay in timber structures. Practical procedures for field testing, workable forms for gathering evaluation data, and guidelines for interpreting data are provided. This information was derived from research that quantified the ability of stress wave timers to detect decay in wood, from laboratory and field studies of deteriorated timber bridges, and most importantly from the experience of timber bridge inspectors familiar with the use of commercially available devices. A table that lists current manufacturers of these devices is included. Properties of wood and important aspects of wood deterioration are also reviewed to provide those who are unfamiliar with wood the basic information necessary to detect decay.

## Principles of Stress Wave Nondestructive Testing for Condition Assessment

As an introduction, a schematic of the stress wave concept for detecting decay within a rectangular wood member is shown in Figure 3.1. First, a stress wave is induced by striking the specimen with an impact device (such as the hammer shown in the illustration) that is instrumented with an accelerometer that emits a start signal to a timer. A second accelerometer, which is held in contact with the other side of the specimen, senses the leading edge of the propagating stress wave and sends a stop signal to the timer. The elapsed time for the stress wave to propagate between the accelerometers is displayed on the timer.

The velocity at which a stress wave travels in a member is dependent upon the properties of the member only. The term ultrasonic and sonic refer only to the frequency of excitation used to impart a wave into the member. (Ultrasound frequencies begin at 20 kHz; sonic frequencies are between 20 Hz and 20 kHz.) All commercially available timing units, if calibrated and operated according to the manufacturer's recommendations, yield comparable results.

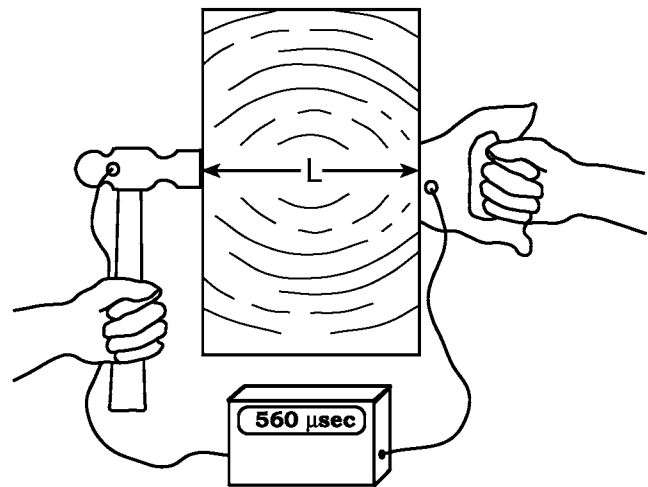
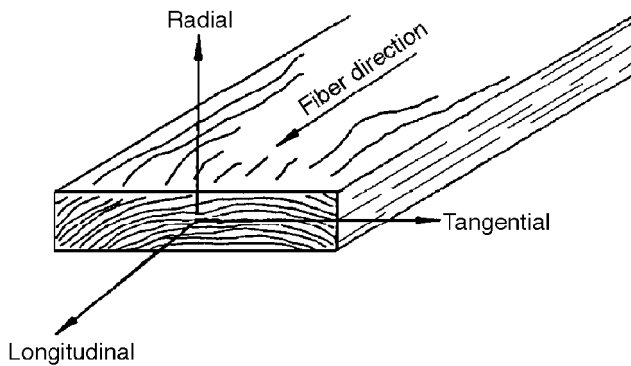


Figure 3.1—Stress wave timer.

The use of stress wave velocity to detect wood decay in timber bridges and other structures is limited only by access to the structural members under consideration. It is especially useful on thick timbers or glued-laminated (glulam) timbers  $\geq 89$  mm ( $\geq 3.5$  in.) where hammer sounding is not effective. Access to both sides of the member is required.

Because wood is an organic substance, material properties and strength vary in accordance with the direction wood is hammered compared with the cell structure orientation. Hammering the end grain of a beam or post will cause a primarily longitudinal shock wave along the length of the cell structure in the timber. Hammering the side or top of the beam will cause a wave across or transverse to the wood cells. Cells are arranged in rings around the center of the tree.

The velocity at which a stress wave propagates in wood is a function of the angle at which the fibers of wood are aligned (which is also a determinant of other physical and mechanical properties). For most structural members, fibers of the



**Figure 3.2—Three principal axes of wood with respect to grain direction and growth rings.**

wood align more or less with the longitudinal axis of the member (Fig. 3.2).

Stress wave transmission times on a per length basis for various wood species are summarized in Table 3.1. Stress wave transmission times are shortest along the grain (with the fiber) and longest across the grain (perpendicular to fiber). For Douglas-fir and Southern Pine, stress wave transmission times parallel-to-the-fiber are approximately 200  $\mu\text{s}/\text{m}$  (60  $\mu\text{s}/\text{ft}$ ). Stress wave transmission times perpendicular to the fiber range from 850 to 1,000  $\mu\text{s}/\text{m}$  (259 to 305  $\mu\text{s}/\text{ft}$ ).

## Effect of Ring Orientation

Researchers have determined that the longest transverse-to-grain transmission times are found at a 45° orientation to the annual rings. The shortest is about 30% faster in a path that is radial (Fig. 3.3). Table 3.2 and Figure 3.4 show stress wave transmission time for wood of good quality at 12% moisture content. These values can vary  $\pm 10\%$  for species variation. These times are based on an assumed stress wave transmission time of 668  $\mu\text{s}/\text{m}$  radially, 800  $\mu\text{s}/\text{m}$  tangentially, and 995  $\mu\text{s}/\text{m}$  at 45° to grain.

## Effect of Decay

The presence of decay greatly affects stress wave transmission time in wood. Table 3.3 summarizes stress wave transmission values obtained from field investigations of various wood members subjected to degradation from decay. Stress wave transmission times perpendicular to the grain are drastically increased when the member is degraded. Transmission times for nondegraded Douglas-fir are approximately 800  $\mu\text{s}/\text{m}$  (244  $\mu\text{s}/\text{ft}$ ), whereas severely degraded members exhibit values as high as 3,200  $\mu\text{s}/\text{m}$  (975  $\mu\text{s}/\text{ft}$ ) or greater.

A 30% increase in stress wave transmission times implies a 50% loss in strength. A 50% increase indicates severely decayed wood (Fig. 3.5). Transverse travel paths are best for finding decay. Parallel-to-grain travel paths can bypass regions of decay.

**Table 3.1—Summary of research on stress wave transmission times for various species of nondegraded wood**

Reference	Species	Moisture content (% OD) <sup>a</sup>	Stress wave transmission time ( $\mu\text{s}/\text{m}$ ( $\mu\text{s}/\text{ft}$ ))	
			Parallel to grain	Perpendicular to grain
Smulski 1991	Sugar maple	12	256 to 194 (78 to 59)	—
	Yellow birch	11	230 to 180 (70 to 55)	—
	White ash	12	252 to 197 (77 to 60)	—
	Red oak	11	262 to 200 (80 to 61)	—
Armstrong et al. 1991	Birch	4 to 6	213 to 174 (65 to 53)	715 to 676 (218 to 206)
	Yellow-poplar	4 to 6	194 to 174 (59 to 53)	715 to 676 (218 to 206)
	Black cherry	4 to 6	207 to 184 (63 to 56)	689 to 620 (210 to 189)
	Red oak	4 to 6	226 to 177 (69 to 54)	646 to 571 (197 to 174)
Elvery and Nwokoye 1970	Several	11	203 to 167 (62 to 51)	—
Jung 1979	Red oak	12	302 to 226 (92 to 69)	—
Ihlseng 1878, 1879	Several	—	272 to 190 (83 to 58)	—
Gerhards 1978	Sitka spruce	10	170 (52)	—
	Southern pine	9	197 (60)	—
Gerhards 1980	Douglas-fir	10	203 (62)	—
Gerhards 1982	Southern pine	10	197 to 194 (60 to 59)	—
Rutherford 1987	Douglas-fir	12	—	1,092 to 623 (333 to 190)
Ross 1982	Douglas-fir	11	—	850 to 597 (259 to 182)
Hoyle and Pellerin 1978	Douglas-fir	—	—	1,073 (327)
Pellerin et al. 1985	Southern pine	9	200 to 170 (61 to 52)	—
Soltis et al. 1992	Live oak	12	—	613 to 1,594 (187 to 486)
Ross et al. 1994	Northern red and white oak	green	—	795 (242)

<sup>a</sup> OD, oven-dry.

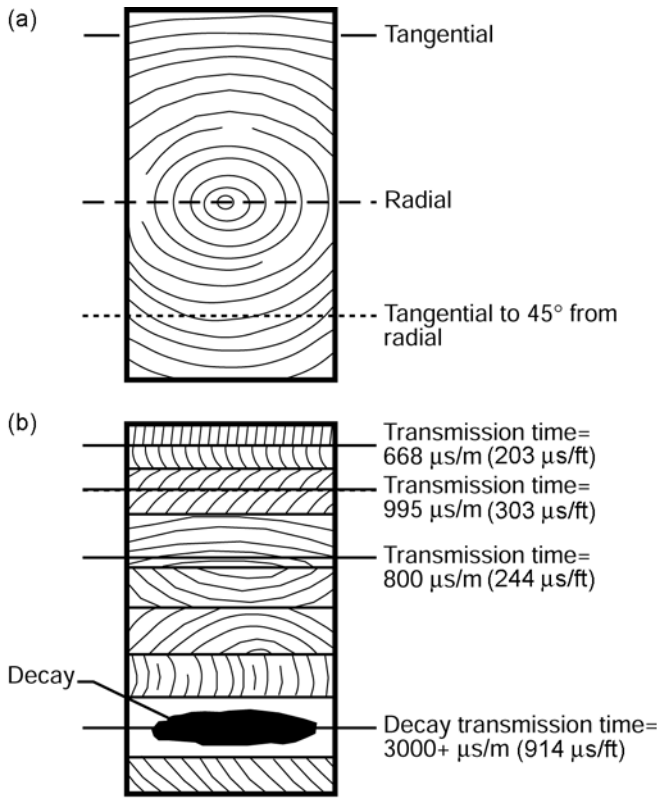


Figure 3.3—Transverse stress wave paths and transmission times: (a) timber, (b) glulam beam.

Table 3.2—Typical stress wave transmission times for nondecayed Douglas-fir at 12% moisture content

Path length (mm (in.))	Stress wave transmission time (μs)		
	Radial	Tangential	45° to grain
64 (2.5)	43	51	64
89 (3.5)	60	71	88
140 (5.5)	94	112	139
184 (7.25)	123	147	183
235 (9.25)	157	188	234
292 (11.5)	195	234	290
342 (13.5)	229	274	340
394 (15.5)	264	315	392
444 (17.5)	297	355	442
495 (19.5)	331	396	492

Weight loss is not a good indicator of decay because considerable strength loss can occur without significant weight loss. As Figure 3.5 illustrates, significant loss of strength occurs before noticeable weight loss.

### Effect of Moisture Content

Considerable research has shown the effect of moisture in wood on stress wave transmission time. Several studies have revealed that stress wave transmission times

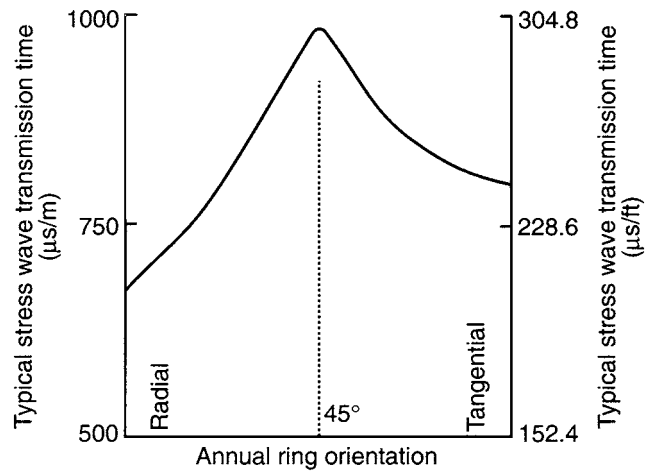


Figure 3.4—Transverse stress wave transmission time compared with annual ring orientation.

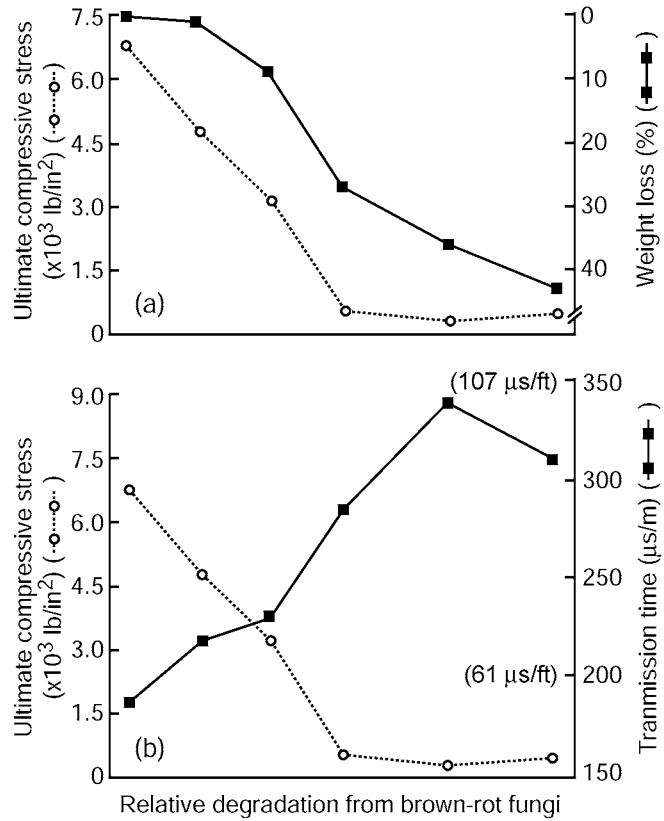


Figure 3.5—Relationship between stress wave transmission time and fungal degradation (Pellerin et al. 1985) (1 lb/in<sup>2</sup> = 6.9 kPa).

perpendicular to the grain of wood follow the relationship shown in Figure 3.6. At moisture contents less than approximately 30%, transmission time decreases with decreasing moisture content. Corrections for various moisture content values are summarized in Table 3.4.

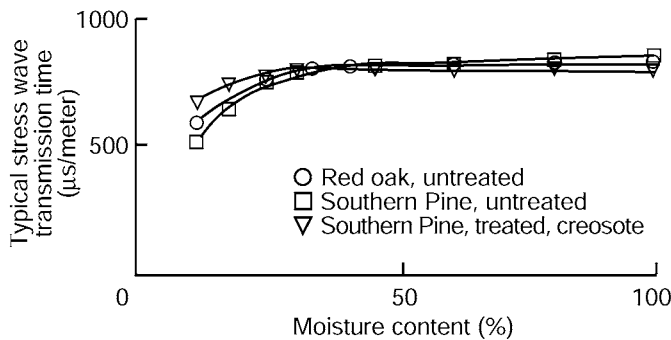
**Table 3.3—Summary of research on use of stress waves for detecting decay in timber structures**

Reference	Structure	Wood product	Test	Analysis
Volny 1992	Bridge	Douglas-fir glulam, creosote pressure treated	Stress wave transmission time perpendicular to grain, across laminations at 0.3-m (0.98-ft) intervals	Sound wood: 1,279 $\mu\text{s/m}$ (390 $\mu\text{s/ft}$ ) Moderate decay: 1,827 $\mu\text{s/m}$ (557 $\mu\text{s/ft}$ ) Severe decay: 2,430 $\mu\text{s/m}$ (741 $\mu\text{s/ft}$ )
Ross 1982	Football stadium	Solid-sawn Douglas-fir, creosote pressure treated	Stress wave transmission time perpendicular to grain, near connections	Sound wood: 853 $\mu\text{s/m}$ (260 $\mu\text{s/ft}$ ) Incipient decay: –Center of members: 1,276 $\mu\text{s/m}$ (389 $\mu\text{s/ft}$ ) –38-mm-thick solid wood shell: 2,129 $\mu\text{s/m}$ (649 $\mu\text{s/ft}$ ) Severe decay: >3,280 $\mu\text{s/m}$ (1,000 $\mu\text{s/ft}$ )
Hoyle and Pellerin 1978	School gymnasium	Douglas-fir glulam arches	Velocity of stress wave transmission time perpendicular to grain, near end supports	Sound wood: 1,073 $\mu\text{s/m}$ (327 $\mu\text{s/ft}$ ) Decayed wood: 1,574 $\mu\text{s/m}$ (480 $\mu\text{s/ft}$ )

At moisture content values greater than approximately 30%, little or no change in transmission time occurs. Consequently, there is no need to adjust the measured values for wood that is tested in a wet condition.

### Effect of Preservative Treatment

Treatment with waterborne salts has almost no effect on stress wave transmission time. Treatment with oilborne preservatives increases transmission time to about 40%



**Figure 3.6—Transverse stress wave transmission times in Southern Pine and red oak piling.**

greater than that of untreated wood. Round poles are usually penetrated to about 37 to 61 mm (1.5 to 2.5 in.). Table 3.5 was calculated to show expected travel time for round poles treated with oilborne preservatives. Although these data illustrate the effect oilborne treatments have on transmission time, these values should not be used to estimate level of penetration.

### Interpretation of Stress Wave Velocity Readings

The guidelines in this chapter are useful in interpreting readings that are less than those for sound wood. Voids and checks will not transmit stress waves. Knots will act as parallel-to-grain wood but are usually oriented perpendicular to the long axis of timber.

Based on the direction and length of the stress wave path in the wood, moisture content of the wood, and whether or not preservative treatment is present, the velocity and travel time for sound wood can be determined. For the transverse direction, the annual ring orientation and the existence of seasoning checks should be recorded.

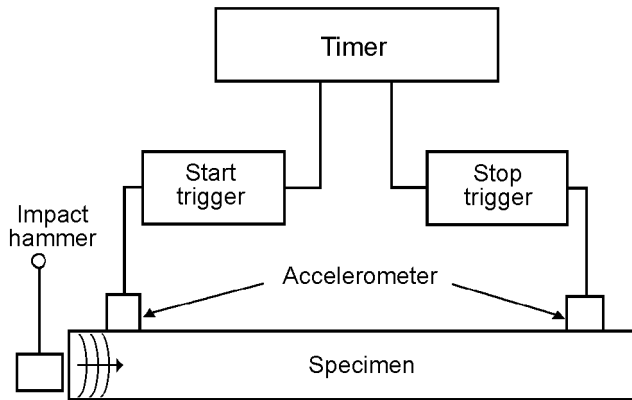
**Table 3.4—Stress wave transmission time adjustment factors for temperature at various moisture contents for Douglas-fir**

Moisture content (%)	Adjustment factors			
	–18 °C (0 °F)	3 °C (38 °F)	27 °C (80 °F)	49 °C (120 °F)
1.8	0.94	0.95	0.97	0.98
3.9	0.95	0.96	0.98	0.99
7.2	0.93	0.98	1.00	1.01
12.8	0.97	0.99	1.00	1.01
16.5	0.99	1.01	1.03	1.05
23.7	1.05	1.07	1.09	1.14
27.2	1.07	1.10	1.12	1.17

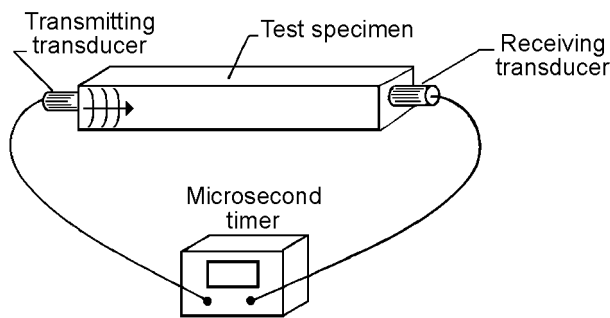


**Table 3.5—Stress wave transmission times for round poles treated with oil-borne preservatives**

Pole diameter (mm)	Stress wave transmission time (μs) for various levels of penetration		
	37 mm	61 mm	Full penetration
294	222	240	300
343	254	271	350
392	286	305	400
441	321	338	450
490	350	370	500
539	386	403	550
588	422	436	600



**Figure 3.7—Technique used to measure impact-induced stress wave transmission times in various wood products.**



**Figure 3.8—Ultrasonic measurement system used to measure stress wave transmission times in various wood products.**

## Measurement of Stress Wave Transmission Time

### General Measurement

Several techniques can be used to measure stress wave transmission time in wood. The most common technique uses simple time-of-flight-type measurement systems. Two commercially available systems that use this technique are illustrated in Figures 3.7, 3.8, and 3.9. Note that for ultrasonic measurement systems, a couplant is used between the transducers and the specimen.

With these systems, a mechanical or ultrasonic impact is used to impart a wave into the member. Piezoelectric sensors are placed at two points on the member and used to detect passing of the wave. The time required for the wave to travel between sensors is then measured.

### Commercially Available Equipment

Several equipment development firms are producing portable equipment based on this concept. Table 3.6 presents contact information for obtaining information on these devices.

## Field Considerations and Use of Stress Wave Methods

### Stress Wave Transmission Time

Figure 3.10 outlines the general procedures used with stress wave nondestructive evaluation methods for field work. Before venturing into the field, it is useful to estimate stress wave transmission time for the size of the members to be inspected. Preceding sections provided information on various factors that affect transmission time in wood. This information can be summarized, as a starting point, by simply using a baseline transmission time of 1,300 μs/m (400 μs/ft). Transmission time, on a per length basis, less than this would indicate sound material. Conversely, transmission time greater than this value would indicate potentially degraded material. Using this value, you can estimate the transmission time for a member by knowing its thickness (path length) and the following formula:

$$T_{\text{baseline}}(\mu\text{s}) = 1,300 \times \text{WTD } \mu$$

where  $T_{\text{baseline}}$  is baseline transmission time (μs) and WTD is wave transmission distance (path length) (m).

[Inch–pound formula:  $T_{\text{baseline}}(\mu\text{s}) = 400 \times \text{WTD}$ , where WTD is wave transmission distance (path length) (ft)]

By knowing this number for various thicknesses, field work can proceed rapidly.

### Field Data Form

An example of a typical field data acquisition form is shown in Figure 3.11. Key items to include on the form are structure name, location, number, inspector, and date of inspection.

### Field Measurements

Field use should be conducted in accordance with instructions provided by equipment manufacturers. In the field, extra batteries, cables, and sensors are helpful. Testing should be conducted in areas of the member that are highly susceptible to degrading, especially in the vicinity of connections and bearing points.

The baseline values provided serve as a starting point in the inspection. It is important to conduct the test at several points at various distances away from the suspect area. In a

**Table 3.6—Commercially available stress wave timing equipment**

Manufacturer	Product	Website	Telephone	Fax	Address	Additional Information
Agricef	USLab	www.agricef.com.br	33 1 56 70 43 80	33 1 48 92 05 85	126 Avenue d'Alfortville, PA Les Gondes, batiment E	
CBS-CBT	Sylvatest-Duo	www.cbs-cbt.com			Fakopp Bt., Fenyo U 26, H-9423 Agfalva, Hungary	Distributors in Japan, China, Hong Kong, Macau, Italy, USA
Fakopp Enterprise	Various models	www.fakopp.com	36 99 33 00 99	36 99 33 00 99		
IML GmbH	IML Micro Hammer	www.imlusa.com	603 253 4600		IML North America, 15 Glidden Rd., Moultonborough, NH 03254	Distributors and sales partners worldwide
Metriguard, Inc.	Models 239A Stress Wave Timer	www.metriguard.com	509 332 7526	509 332 0485	2465 NE Hopkins Court, Pullman, WA 99163	
James Instruments, Inc.	V-Meter MK IV	www.ndtjames.com	773 463 6565	773 463 0009	3727 N. Kedzie Avenue, Chicago, IL 60618-4545 USA	Distributor in Europe
Olson Instruments, Inc.	Various models	www.olsoninstruments.com	303 423 1212	303 423 6071	12401 W. 49th Avenue, Wheat Ridge, CO 80033-1927 USA	



sound member, little deviation is observed in transmission times. If a significant difference in values is observed, the member should be considered suspect.

## Data Analysis and Summary Form

When data have been gathered, it is useful to present them in an easy-to-read manner. Figure 3.12 illustrates several data summaries. From these, the presence and extent of degradation can readily be seen. The top and bottom illustrations show a timber cross section with visual defects and stress wave times noted. The center drawing illustrates the side view of a timber, with stress wave travel times noted.

## References

- Armstrong, J.P.; Patterson, D.W.; Sneckenberger, J.E. 1991. Comparison of three equations for predicting stress wave velocity as a function of grain angle. *Wood and Fiber Science*. 23(1): 32–43.
- Elvery, R.H.; Nwokoye, D.N. 1970. Strength assessment of timber for glued laminated beams. In: *Proceedings, Paper II, Nondestructive testing of concrete and timber, organized by the Institution of Civil Engineering and the British Commission for Nondestructive Testing; 1969 June 11–12*. London, BC: Institute of Civil Engineering: 105–110.
- Gerhards, C.C. 1978. Effect of earlywood and latewood on stress-wave measurements parallel to the grain. *Wood Science*. 11(2): 69–72.
- Gerhards, C.C. 1980. Effect of cross grain on stress waves in lumber. Res. Pap. FPL–RP–368. Madison, WI: U.S. Department of Agriculture, Forest Service, Forest Products Laboratory.
- Gerhards, C.C. 1982. Effect of knots on stress waves in lumber. Res. Pap. FPL–RP–384. Madison, WI: U.S. Department of Agriculture, Forest Service, Forest Products Laboratory.
- Hoyle, R.J.; Pellerin, R.F. 1978. Stress wave inspection of a wood structure. In: *Proceedings, 4th symposium on nondestructive testing of wood; 1978 August 28–30; Vancouver, WA*. Pullman, WA: Washington State University: 33–45.
- Ihlseng, M.C. 1878. The modulus of elasticity in some American woods, as determined by vibration. *Van Nostrand's Engineering Magazine*. Vol. XIX: 8–9.
- Ihlseng, M.C. 1879. On a mode of measuring the velocity of sound in wood. *American Journal of Science*. 3d Series. 17I(98): 125–133.
- Jung, J. 1979. Stress wave grading techniques on veneer sheets. Gen. Tech. Rep. FPL–GTR–27. Madison, WI: U.S. Department of Agriculture, Forest Service, Forest Products Laboratory.
- Pellerin, R.F.; De Groot, R.C.; Esenther, G.R. 1985. Non-destructive stress wave measurements of decay and termite attack in experimental wood units. In: *Proceedings, 5th symposium on nondestructive testing of wood; 1985 September 9–11; Pullman, WA*. Pullman, WA: Washington State University: 319–353.
- Ross, R.J. 1982. Quality assessment of the wooden beams and columns of Bay C of the east end of Washington State University's football stadium. Unpublished research. Pullman, WA: Washington State University.
- Ross, R.J.; Ward, J.C.; TenWolde, A. 1994. Stress wave non-destructive evaluation of wetwood. *Forest Products Journal*. 44(7/8): 79–83.
- Rutherford, P.S. 1987. Nondestructive stress wave measurement of incipient decay in Douglas Fir. Pullman, WA: Washington State University. M.S. thesis.
- Smulski, S.J. 1991. Relationship of stress wave and static bending determined properties of four northeastern hardwoods. *Wood and Fiber Science*. 23(1): 44–57.
- Soltis, L; Baker, A.; Ferge, L.; [et al.]. 1992. USS Constitution—inspection and evaluation procedures for live and white oak members. Report submitted to U.S.Navy, Maintenance and Repair, USS Constitution, Boston Naval Shipyard, Charlestown, MA.
- Volny, N.J. 1992. Timber bridge inspection case studies in use of stress wave velocity equipment. In: *Proceedings, 8th symposium on nondestructive testing of wood; 1991 September 23–25; Vancouver, WA*. Pullman, WA: Washington State University.





# New Techniques and Technologies

Xiping Wang  
Zhiyong Cai

The wood products research community has invested considerable resources investigating the suitability of several techniques for assessing the condition of in-service wood. Acoustic tomography, transverse vibration, and three-dimensional laser scanning are three techniques that have shown promise for in-place assessment of wood structures.

Advances in computing technologies have resulted in a strong interest in using acoustic tomography to assess in-service timbers. Originally developed for assessing the condition of urban trees, this technique builds upon the successful use of acoustic methods to detect deterioration in wood. It provides a more detailed assessment than commonly used techniques and processes baseline results to provide a two-dimensional (2D) image of the cross section of a timber.

The methods and technologies described in the first three chapters are widely used to assess the condition of individual members or small areas within a wood member. Recently, a series of experiments were conducted to examine the feasibility of in-place testing of entire structural wood systems. Transverse vibration nondestructive testing techniques were used to estimate in-place stiffness of short-span timber bridges and building floor systems.

Use of three-dimensional (3D) laser scanning technologies to obtain as-built records for historic covered bridges has been investigated. These technologies show promise as part of a comprehensive inspection approach to historic structures.

Overviews of these techniques and results obtained from their use are presented in this chapter. A list of relevant technical publications is included.

## Acoustic Tomography

Stress wave timing, although widely used in building inspection, has its limitations. A single-pass stress wave measurement can only detect internal decay that is greater than 20% of total cross-sectional area (Wang et al. 2004). To increase the reliability of the inspection and better define extent and location of any internal decay in a structural timber would require multiple acoustic measurements in different orientations at one cross section, especially in suspect areas. Two-dimensional tomographic inversions of stress wave data from multiple path measurements could allow inspectors to obtain a color map, or tomogram, of the distribution

of stress wave velocity in the cross section, enabling a more direct imagery-based assessment.

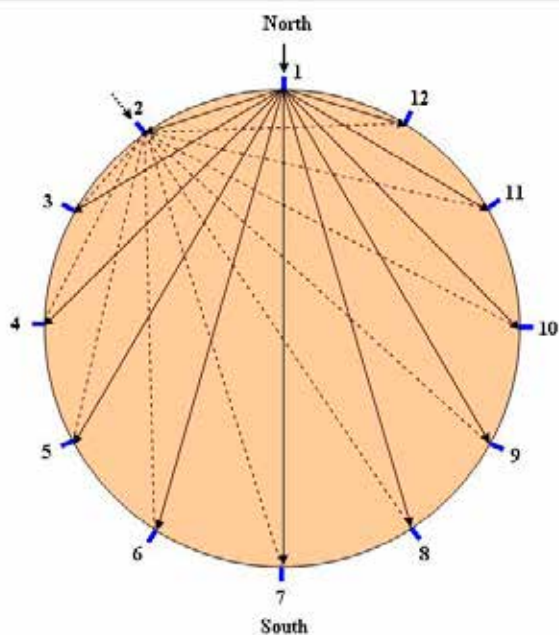
Acoustic tomography is a nondestructive evaluation technology for decay detection in urban trees and structural timbers. Commonly used tomographic image reconstruction is based on time of flight (TOF) data obtained through multipath measurements. It allows users to visualize the velocity distribution of acoustic waves as the waves propagate through the cross section of a wood member. Because acoustic velocity is directly related to density and modulus of elasticity of wood, acoustic velocity mapping of a cross section can be used as a diagnostic image to detect internal wood decay (Bucur 2003). Application of this technology was initially demonstrated by Tomikawa et al. (1990) for inspecting the internal condition of wooden poles. Later, researchers investigated the applicability of the technology to detect internal decay in live trees (Divos and Szalai 2002; Gilbert and Smiley 2004; Wang et al. 2004, 2009; Wang and Allison 2007; Allison et al. 2008; Deflorio et al. 2008). Although field use of acoustic tomography is largely with urban tree inspections, the potential of this technology for assessing condition of large timber piles or columns in wood structures has been demonstrated and its application in the field of structural inspection will likely increase (Divos 2006, Wang and Wacker 2006, Yu et al. 2009, Dackermann et al. 2014).

## Basics of Acoustic Tomography

Acoustic tomography is a diffraction-type tomography that utilizes acoustic impulses as an energy source. In contrast to ionizing radiation, acoustic waves do not travel along straight rays and the projections are not line integrals. The accuracy of tomography with acoustic energy is limited by the diffraction of the energy field and also affected by frequency of the acoustic waves, number of sensors used, and the applied evaluation algorithm. The main benefits of this technique are that (1) it is a noninvasive method, (2) the equipment is safe to operate, and (3) the equipment is relatively low cost. Three main types of algorithms can be used to form tomographic images from acoustic data: transform techniques, iterative methods, and direct inversion techniques (Bucur 2003). The most commonly used parameter in acoustic imaging is time of flight (TOF), which can be easily obtained through a pair of sensors.



**Figure 4.1—Acoustic tomography test on a timber post.** (Rinn 2006)



**Figure 4.2—Sensor arrangement and paths of acoustic measurement on a round timber.**

For TOF data acquisition, multiple sensors must be attached around the circumference of a timber. Figure 4.1 shows an example of acoustic tomography measurement with a chain of sensors attached to the base of a timber post through sensor pins (Rinn 2006, Dackermann et al. 2014). Typically, 8 to 12 acoustic sensors are used in most applications, including trees and structural timbers (posts, columns, and beams), to obtain a reasonably good resolution of tomographic images. In cases where higher resolution is desired for critical structural timbers, the number of sensors can be increased to 24 or 36, depending on availability of sensors.

Coupling of the acoustic sensors to the timber under inspection is typically achieved through pins or nails when impulses are generated by a hammer impact. When ultrasonic

sensors are used to test solid-sawn or glued-laminated timbers, gel-type coupling can provide good acoustic impedance. Field tomography measurement can also be expedited by using a specially designed flexible mounting frame that facilitates the sensor installation process.

Figure 4.2 illustrates the sensor arrangement and paths of acoustic waves for a tomography test on a round timber. Acoustic TOF data is obtained by sequentially tapping each pin using a steel hammer. A complete TOF data matrix can be obtained through this measurement process at each test location.

### Equipment and Operating Procedures

Three commercial tools are currently available for performing TOF acoustic tomography testing on trees and structural timbers: PiCus Sonic Tomograph (Argus Electronic GmbH, Rostock, Germany), Arbotom 3D Impulse Tomograph (RinnTech, Heidelberg, Germany), and ArborSonic 3D Acoustic Tomograph (Fakoop Enterprise, Sopron, Hungary). An acoustic tomography unit generally comes with a series of low-noise piezoelectric sensors, sensor attachment pins, amplifier boxes, connection cables, a rechargeable battery pack, a tape or caliper for measuring sensor positions, a steel hammer for tapping the sensors, and a software package for mapping geometry of the cross section, collecting TOF data, and generating tomograms. Total measurement time for one cross section of a timber is from 20 to 30 min., depending on the number of sensors used and ease of accessing the test location. Measurements at several heights can be assembled into a 3D model when needed.

Acoustic tomography measurement is generally conducted based on following operating procedures:

1. Select the cross section of the timber to be tested; measure the circumference of the cross section; determine the number of sensors to be used.
2. Mark the starting point (sensor No. 1) at the cross section, place a tape measure around the cross section, and then mark the locations of rest of the sensors.
3. Drive attachment pins into the timber using a hammer and attach the piezoelectric sensors on the pins (spiked sensors can be inserted into timber directly).
4. Measure the distances between the sensors with a caliper, and enter the measured data into a computer.
5. Determine the geometry of the cross section using the software package.
6. Conduct acoustic measurements: starting with sensor No. 1 and proceeding to each sensor in turn, tap each sensor with a steel hammer to generate sound waves. The tool measures the time of flight with microsecond precision to each transducer and transmits the data to the computer.



- The software calculates the internal acoustic velocity distribution in the cross section and displays as a colored tomogram.

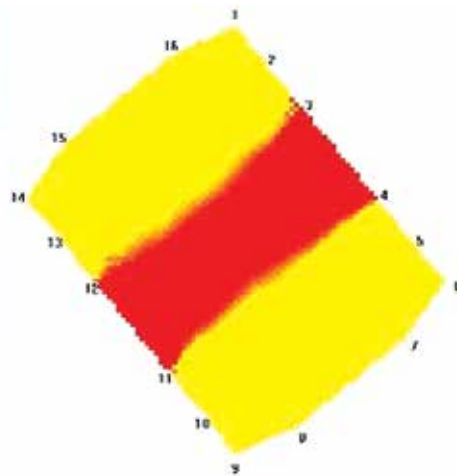
**Applications**

*Glued-Laminated Timber Specimen:* Divos (2006) demonstrated the use of acoustic tomography on a section of glued-laminated timber (glulam) with a simulated void (Fig. 4.3). Sixteen sensors were strategically placed on four faces of the specimen (Fig. 4.3a). The center void can be visualized as a red color zone in the tomogram (Fig. 4.3b).

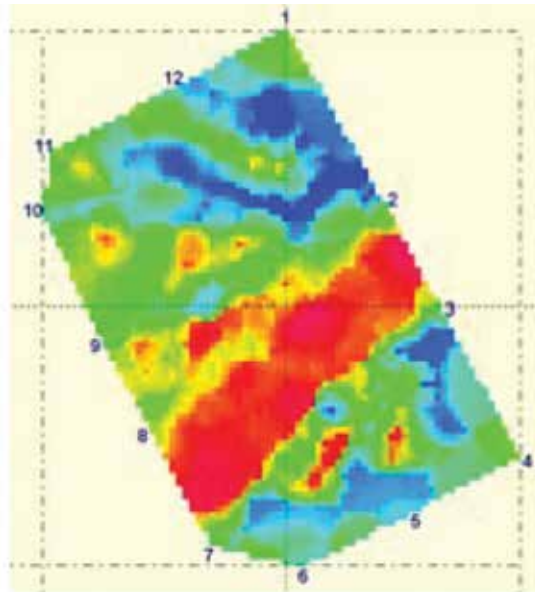
*Wood Structural Members:* Yu et al. (2009) inspected the wood structural members of the Imperial Palace, Beijing, China, using an impulse stress wave tomography tool. An

internal crack in the timber was properly identified in the tomogram (Fig. 4.4). The results suggested that at least 12 sensors should be placed around a 54 by 30 cm timber in order to obtain a reasonably accurate tomographic image.

*In-Service Masts of Historic Wooden Ship:* Wang and Wacker (2006) inspected the masts of the U.S. Brig Niagara, a reconstruction of an early 19th century wooden warship of the U.S. Navy, using acoustic tomography technique (Fig. 4.5). The fore mast and main mast are both fabricated from southern yellow pine glulam. Primary concerns were locations at the main deck level where water often comes in and creates moist conditions. Tomography testing on both masts indicated sound cross sections at the deck level, which were further confirmed by resistance drilling tests.



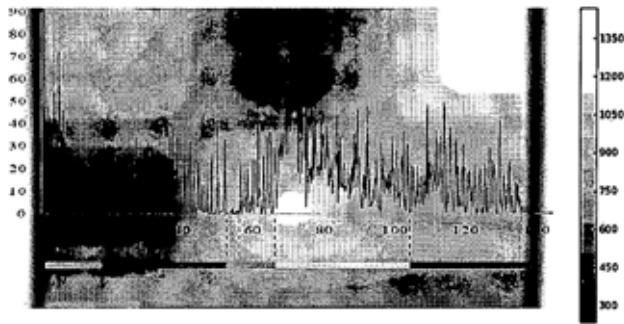
**Figure 4.3—Acoustic tomography test on a glued-laminated specimen with a simulated void (Divos 2006).**



**Figure 4.4—Acoustic tomogram revealed internal crack of an old timber at the Imperial Palace in Beijing (Yu et al. 2009).**



**Figure 4.5—Inspection of the masts of the U.S. Brig Niagara using acoustic tomography.**



**Figure 4.6—Tomogram of a timber section superimposed with the relative resistance profile (Riggio and Pizza 2011).**

*Tomography Complemented with Micro Resistance Drilling:* Riggio and Piazza (2011) used a multi-channel device (TDAS 16 – Boviar SRL) with an ultrasonic probe of 55 kHz to map decayed areas in timbers. Acoustic velocity maps were represented in a diagram by 256 levels of grey, with the white level corresponding to maximum velocity and the black level corresponding to minimum velocity. Complementary to TOF tomography, micro resistance drilling tests were carried out in portions of the sections to provide data for confirmation of the tomograms. Figure 4.6 shows the tomogram acquired from a decayed cross section superimposed with a relative resistance profile. The x axis of the plot is positioned along the corresponding drilling path. The presence of void and poor quality of the timber can be identified by low values of both acoustic velocity and relative drilling resistance. The void area in the left portion of the timber is confirmed by the almost flat resistance profile, and the sound wood in the central part is confirmed by the high resistance profiles. Results indicated that integral of relative resistance profile divided by penetration depth and average acoustic velocity values in tomograms can be used to give general interpretation of the tests.

## Limitations

Although acoustic tomography has been successfully used to detect moderate to severe internal decay in structural timbers, the detection of early stage of decay using such technology still constitutes a challenge because (1) acoustic tomography techniques currently used are largely based on TOF measurements, which limit the accuracy and resolution of the tomography images obtained; (2) the construction of tomogram from TOF data is affected by pronounced anisotropy of timber in terms of microstructures and wood properties; and (3) interpretation of tomograms is not quantitative in nature and often needs further confirmation or verification by other means. For field application, it is recommended that complementary nondestructive test methods be used to obtain local quantitative information, such as a resistance drilling test, to verify the internal condition of the area.

## Transverse Vibration of Structural Systems

Inspection and evaluation of existing timber structures has historically been limited to evaluating each structural member individually, which requires a time-consuming inspection. Sometimes individual members are not accessible and therefore difficult to inspect. Low-frequency transverse vibration has been studied for over 50 years as a potential method for evaluating wood-based products. However, the nondestructive evaluation of a timber floor system using transverse vibration was researched about 15 years ago. Transverse vibration was used to evaluate properties of new and salvaged individual floor joists (Cai et al. 2000), and then these joists were used to fabricate floor systems of five joists and attached flooring deck in the laboratory. The responses of these floor systems were then evaluated in the laboratory using transverse vibration (Cai et al. 2002). These pilot studies used an impact load to initially displace the structure; the free vibration characteristics of individual joists or the whole floor system were measured. The salvaged joists tested in these studies had seasoning checks, splits, and some edge decay, which resulted in lower stiffness values than those of the new joists. Later, forced vibration was imposed by a motor with an eccentric rotating mass attached to the floor decking (Soltis et al. 2002). Motor speed could be manually changed, and the rotating mass forced the floor to vibrate at its frequency. The resonant vibration was observed by changing the speed of the rotating mass until maximum deflection was reached. The observed resonant frequency of the wood floor system should be close to its natural frequency, which is highly related to its stiffness and its supporting boundary condition. The transverse vibration technique was used later to assess single-span timber bridges (Wang et al. 2005).

## Fundamentals

Jayne (1959) applied a forced transverse vibration technique for evaluating a single wood member. Pellerin (1965)

significantly improved the technique by using free transverse vibration with dimension lumber. A vibrating beam can be modeled as the vibration of a mass  $M$  that is attached to a weightless spring and internal damping. The generalized equation of motion of a mass under damped forced vibration is derived from the classical spring-dash-pot analogy. When a forcing function equaling  $P_0 \sin \omega t$  ( $P$  is force and  $\omega$  is frequency, or zero) is applied for forced (or free) vibration, the equation of motion of  $M$  can be expressed as

$$M \left( \frac{d^2x}{dt^2} \right) + D \left( \frac{dx}{dt} \right) + Kx = P_0 \sin \omega t \quad (1)$$

where  $K$  is the elastic constant of the spring and  $D$  is the damping coefficient of the dashpot.

A solution for Equation (1) is obtained as

$$x(t) = \frac{P_0}{\sqrt{(-\omega^2 M + K)^2 + (\omega D)^2}} \sin(\omega t - \phi) \quad (2)$$

where

$$\phi = \tan^{-1} \frac{\omega D}{-\omega^2 M + K} \quad (3)$$

When the beam is at resonance ( $dx/d\omega = 0$ ), the solution for  $K$  (with correction for mass and substitutions of appropriate constants) leads to the following equation for dynamic modulus of elasticity (MOE) of the beam:

$$\text{MOE} = \frac{f_r^2 W L^3}{n^2 I g} \quad (4)$$

where  $f_r$  is resonant frequency (Hz),  $W$  is beam weight (lb or kg),  $L$  is beam span (in. or m),  $I$  is beam moment of inertia (in<sup>4</sup> or m<sup>4</sup>);  $g$  is gravitational acceleration (386 in/s<sup>2</sup> or 9.8 m/s<sup>2</sup>),  $n$  is a constant dependent on mode of support (equal to 12.65 for freely supported at two nodal points and 2.46 for supported at the ends).

The logarithmic decrement,  $\delta$ , is used as a measure of energy dissipation and can be expressed as (for free vibrations)

$$\delta = \frac{1}{n-1} \ln \frac{A_1}{A_n} \quad (5)$$

where  $A_1$  and  $A_n$  are the amplitudes of two oscillations  $n-1$  cycles apart. For forced vibrations,

$$\delta = \frac{\pi \Delta f}{f_r} \frac{1}{\sqrt{(A_r/A)^2 - 1}} \quad (6)$$

where  $\Delta f$  is the difference in frequency of two points of

amplitude  $A$  on each side of a resonance curve,  $f_r$  is the frequency at resonance and  $A_r$  is the amplitude at resonance.

Note that Equation (4) represents the relationship for a simply supported idealized beam. This formula, however, is frequently used to estimate the relationship for simply supported systems as well.

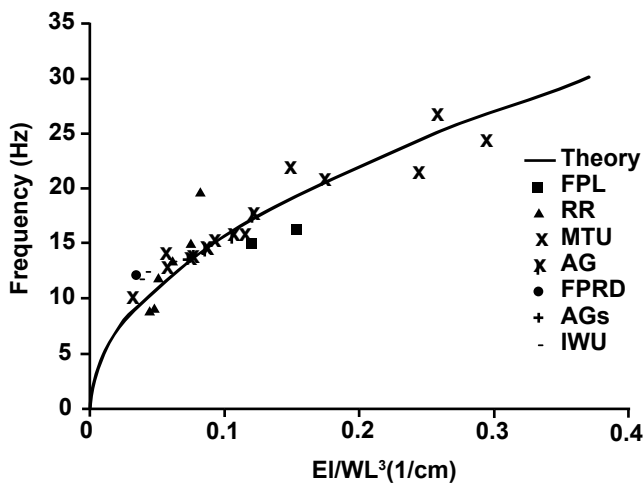
## Exciting and Measuring System

Floor systems were subjected to both free and forced vibration. Free vibration was initiated by impact from a large hammer. Forced vibration was imposed by a motor with an eccentric rotating mass attached to the floor decking. Motor speed could be manually changed from rest up to a maximum of 2,500 rpm. The weight of the rotating mass was based on the total weight of the floor system (up to 1 kg) and the eccentricity from the rotating axis. The response to vibration was measured at the bottom of the joists using a linear variable differential transducer (LVDT). The time-deflection signal was recorded by an oscilloscope. For free vibration, the damped natural frequency was determined as the inverse of the period measured from the time-deflection signal; the damping ratio was determined from the same signal using the classic log-decrement technique. For forced vibration, the damped resonant frequency was determined by increasing motor speed until maximum deflection resonance was observed and then measuring frequency from the time deflection signal.

## Results and Implementation

A total of 30 in-place floors and four configurations of two salvaged floor sections were tested both dynamically and statically (Forsman and Erickson 2001, Soltis et al. 2002, Wang et al. 2005, Hunt et al. 2007). The forced natural frequencies and configuration were measured. According to Equation (4), the square of forced damped natural frequency for each floor is correlated to the factor  $EI/WL^3$ , where  $EI$  was determined by the static load test,  $W$  is estimated weight of the floor/section, and  $L$  is measured floor span. The solid curve in Figure 4.7 is the hypothesized response of the natural frequencies with different  $EI/WL^3$  configurations. Data points in Figure 4.7 are measured natural frequencies of the prior tested laboratory-built floor sections. A least squares analysis yields a coefficient of determination  $r^2 = 0.85$  for comparing empirical data versus theory. Based on these favorable results, the hypothesis that in-place wood floors, such as those tested in this project, can be modeled as a simply supported, one-way beam system under transverse vibration with viscous damping was not rejected.

The goal of implementing this technique was to develop a methodology of using the measured damped natural frequency of a floor to safely predict the floor's  $EI$ . Although the theory fits experimental data extremely well, 95% confident limits could be used to account for variability. Similar to establishing allowable bending stress for lumber, the fifth



**Figure 4.7—Scatter plot of in-place floor test data and previously tested lab-built floor sections.**

percentile exclusion limit is used as the control curve to estimate allowable  $EI/WL^3$ . In practice, a wood structural system (i.e., an in-place floor) would be transversely resonated to determine its damped natural frequency; the frequency value would be used to obtain the associated value of  $EI/WL^3$  with 95% confidence level for the system. The  $EI$  of the system can be isolated from this value by measuring the floor span and estimating the weight of the system. The  $EI$  will provide a good estimation of overall structural condition of the wood structural system.

## Laser Scanning of Structures

Three-dimensional (3D) laser scanners are instruments that record precise and accurate surface data of objects in a non-destructive manner. These instruments use a beam of infrared light to calculate and record the distance to an object, typically as data points with spatial coordinates. These data are then analyzed using various types of computer software to generate a detailed image of coordinates and dimensions. Three-dimensional laser scanners have been used successfully to digitize objects of various sizes ranging from small diagnostic artifacts to large, complex sites of monumental architecture (FARO Technologies 2011a,b).

A number of companies manufacture various types of 3D laser scanners. Generally, these units use light detection and ranging technology (LiDAR), where laser pulses determine the distance to an object or surface. The distance to an object is determined by using time-of-flight between transmission of a pulse and detection of the reflected signal. A point cloud of data is then collected and can be converted into the true shape of the object.

Laser scanning technologies have been investigated for use in the assessment of bridges. The Pennsylvania Department of Transportation (PennDOT), for example, completed an

initial study in 1999 with the goal of evaluating the technology for creating as-built drawings. A comparison of traditional and 3D scanning estimated an overall time savings of 100+ person-hours through the use of 3D scanning (Foltz 2000). Based on these results, PennDOT purchased two laser scanners in 2000. A second assessment was completed in 2003 showing that laser scanning could be used cost effectively for preliminary surveys to develop triangular network (TIN) meshes of roadway surfaces and to measure bridge beam camber more safely and quickly than with conventional approaches. Other applications noted in this publication showed potential applications for laser scanning to include developing as-built drawings of historical structures, such as the bridges of Madison County, Iowa.

Covered bridges are part of the fabric of American history. Although much effort is expended to preserve these structures, many are lost forever. The National Park Service's Historic American Engineering Record (HAER) has efforts under way to document historic structures. Their Level I documentation is defined in the Secretary of the Interior's Standards and Guidelines for Architectural and Engineering Documentation and consists of measured and interpretive drawings, large-format photographs, and written historical reports. To assist in this effort, newer technologies needed to be explored that can provide as-built records at a faster rate and with more accuracy.

The University of Minnesota Duluth's Natural Resources Research Institute (UMD NRRRI), in cooperation with the USDA Forest Products Laboratory and Federal Highway Administration, recently completed a study to examine the use of laser scanning technologies for providing as-built records for historic covered timber bridges. Additional support for the study was provided by the City of Zumbrota, Minnesota, via funds from the Operational Research Program (OPERA) of the Minnesota Local Road Research Board. Following is a brief description of that study; detailed documentation is presented in Ross and others (2012).

The bridges for scanning and assessment used in this study are located in Wisconsin, Iowa, and Minnesota. Key background information (Table 4.1), detailed descriptions, and photographs are summarized in the following paragraphs. Contact was made with the appropriate government or administrative staff for each bridge, and permission was also secured to obtain scans. Note that four of the bridges scanned included the historic Madison County, Iowa, bridges.

Laser scanning was completed by Sightline, LLC (Milwaukee, Wisconsin), a private firm that specializes in the use of laser scanning technologies with structures. A FARO LS 880 model and a Photon 120 model (FARO Technologies, Lake Mary, Florida) used similar technology to acquire the scan points. A laser beam is emitted from a rotating mirror toward the area being scanned. The laser beam is then

**Table 4.1—Background information on the historic covered timber bridges used in this study**

State	City	Bridge	Year built	Span (ft)	Placement on National Register of Historic Places	Design
Wisconsin	Cedarburg	Red	1876	120	March 14, 1973	Lattice through truss
Iowa	Winterset	Roseman	1883	106	September 1, 1976	Lattice through truss
Iowa	St. Charles	Imes	1870	81	February 9, 1979	Lattice through truss
Iowa	Winterset	Hogback	1884	106	August 28, 1976	Lattice through truss
Iowa	Winterset	Cutler–Donahoe	1871	79	October 8, 1976	Lattice through truss
Minnesota	Zumbrota	Zumbrota	1869	120	February 20, 1975	Lattice through truss

reflected back to the scanner by objects in its path. The distance to the objects defining an area is calculated, as well as their relative vertical and horizontal angles (FARO Technologies 2011a,b). Approximately 20 to 30 scans were completed for each bridge from a variety of angles using a FARO LS 880 laser scanner. Figure 4.8 shows a FARO laser scanner being used to inspect a historic covered bridge. The scanning process consisted of scans that were completed by Sightline, and data processing was completed by the University of Minnesota Duluth Natural Resources Research Institute (UMD NRRI). The steps in the process were as follows (with an estimate of time required for each step):

1. Paper “targets” were placed in numerous locations on the bridge for use in linking up to 30 individual laser scans together. Time duration: 2 person-hours.
2. A FARO LS 880 3D laser scanner was used to conduct the scan. The scanner was placed at several vantage points inside and outside the bridge, so that all visible surfaces of the bridge could be documented. Individual scans were completed in approximately 15 to 20 min. Each completed scan was saved to a computer as an .ls file. (A computer with substantial computing power and RAM is highly recommended to process the millions of data points created during the scanning process.) Time duration: 10 person-hours.
3. After all visible portions of the bridge were scanned, the software files were linked using FARO Scene software. This software allows an individual to identify the targets placed prior to the scanning process and use them to link or attach one scan to another. It is also possible to filter, using various techniques or software, extraneous images (for instance, a vehicle traveling across the bridge or background vegetation). The process of linking two individual scans was repeated several times until all scans were compiled into one large scan depicting the entire bridge. Time duration: 9 person-hours.
4. Once a bridge was completely assembled using all the individual scans, it was exported as a point cloud, depicting all visible aspects and actual dimensions of the

**Figure 4.8—A FARO laser scanner used to scan a historic covered bridge.**

bridge. This cloud of data was then exported into AutoCAD software (Autodesk, Inc., San Rafael, California) using an add-in provided by Kubit USA (Houston, Texas). This add-in allows a user to import point cloud files in addition to the ones inherently recognized by AutoCAD 2011 and has additional modeling tools for working directly with point cloud data in AutoCAD. Once a point cloud has been exported into AutoCAD, it can be divided into multiple cross sections. This is done so that specific components of the bridge can be seen more clearly. From this point, two dimensional (2D) and 3D models of the bridge were generated. Time duration: 40+ person-hours.

Several types of images can be presented from processing point cloud data. These images include a point cloud image resulting from only one scan, a point cloud image created from multiple scans, a parametric picture created from a point cloud scan, a point cloud image imbedded in AutoCAD, and 2D/3D AutoCAD images. These images can be created using FARO Scene software or AutoCAD 2011 with a Kubit USA add-in. As to project activities, the majority of the scan processing for the Cedarburg, Wisconsin, bridge was completed by Sightline, LLC. Processing of scan data for the Madison County, Iowa, bridges and the Zumbrota, Minnesota, bridge was completed by the UMD NRRI. The

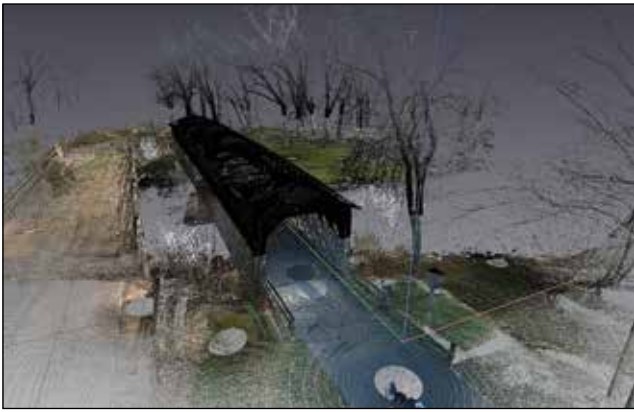


Figure 4.9—Point cloud image of the Cedarburg Bridge (SightLine, LLC).



Figure 4.10—3D AutoCAD image of the Cedarburg Bridge embedded in point cloud data (SightLine, LLC).



Figure 4.11—Dimensioned point cloud image of bridge entry on Cedarburg Bridge (SightLine, LLC).

project team decided that based on processing time estimates, detailed in-point cloud and 3D AutoCAD data would be provided for the Cedarburg, Imes, and Zumbrota Bridges, with only point cloud data for the Hogback, Cutler–Donahoe, and Roseman Bridges. All digital points could be further processed to develop detailed dimensional information because point cloud images are considered accurate data. Point cloud images could also be further processed using Kubit USA add-ins for AutoCAD 2011. Each bridge scan and AutoCAD image is shown in the following sections.

### Cedarburg, Wisconsin, Covered Bridge

Figures 4.9 to 4.11 show various images created from 3D laser scanning conducted during the project for the Cedarburg Bridge. This includes point cloud images and AutoCAD drawings created from the point cloud images.

### Imes Bridge, Madison County, Iowa

The Imes Bridge is the only Madison County Bridge for which the point cloud data were used to create AutoCAD drawings. For the Imes Bridge, the data show accurate dimensions and shape of the bridge at the time of scanning. No corrections were made to straighten any bridge members, such as would be done to create new construction drawings.

### References

- Allison, R.B.; Wang, X.; Ross, R.J. 2008. Visual and nondestructive evaluation of red pines supporting a ropes course in the USFS Nesbit Lake Camp, Sidnaw, Michigan. In: Proceedings, 15th international symposium on nondestructive testing of wood. Madison, WI: Forest Products Society: 43–48.
- Bucur, V. 2003. Nondestructive characterization and imaging of wood. Berlin, Heidelberg, Germany: Springer-Verlag: 354 p.
- Cai, Z.; Hunt, M.O.; Ross, R.J.; Soltis, L.A. 2000. Static and vibration moduli of elasticity of salvaged and new joists. *Forest Products Journal*. 50(2): 35–40.
- Cai, Z.; Ross, R.J.; Hunt, M.O.; Soltis, L.A. 2002. Pilot study to examine use of transverse vibration nondestructive evaluation for assessing floor systems. *Forest Products Journal*. 52(1): 89–93.
- Dackermann, U.; Crews, K.; Kasal, B.; Li, J.; Riggio, M.; Rinn, F.; Tannert T. 2014. In situ assessment of structural timber using stress-wave measurements. *Materials and Structures*. 47(5): 787–803.
- Deflorio, G.; Fink, S.; Schwarze, F.W.M.R. 2008. Detection of incipient decay in tree stems with sonic tomography after wounding and fungal inoculation. *Wood Science and Technology*. 42:117–132

- Divos, F. 2006. Stress wave based acoustic tomography. IUFRO Workshop on Nondestructive Testing of Wood, Harbin, China. August 7–9, 2006 (unpublished presentation, personal communication).
- Divos, F.; Szalai, L. 2002. Tree evaluation by acoustic tomography. In: Proceedings of the 13th international symposium on nondestructive testing of wood. Madison, WI: Forest Products Society: 339–349.
- FARO Technologies. 2011a. FARO laser scanner training [Print presentation]. Lake Mary, FL: FARO Technologies.
- FARO Technologies. 2011b. Measuring arms, laser tracker, laser scanner. In: FARO laser scanner focus 3D—applications. Lake Mary, FL: FARO Technologies. <http://www.faro.com/focus/applications>.
- Foltz, L. 2000. 3D laser scanner provides benefits for PennDOT bridge and rockface surveys. Professional Surveyor magazine. (May). <http://www.profsurv.com/magazine/article.aspx?i=590>.
- Forsman, J. W., and Erickson, J. R. \_2001\_. “Final report on a study of methods to determine the effect of decayed lumber in floor systems.” School of Forestry and Wood Products, Michigan Technological Univ., Houghton, Mich.
- Gilbert, E.A.; Smiley, E.T. 2004. PiCUS sonic tomography for the quantification of decay in white oak (*Quercus alba*) and hickory (*Carya* spp.). Journal of Arboriculture. 30(5):277–280.
- Hunt, M.O., R.J. Ross, X. Wang, L.A. Soltis, R.R. Leavitt, and Z. Cai. 2007. Assessment of in-place wood floor systems. J. of Architectural Engineering. 13( 1): 30-35.
- Jayne, B.A. 1959. Vibrational properties of wood as indices of quality. Forest Products Journal. 9(11): 413–416.
- Pellerin, R.F. 1965. A vibrational approach to nondestructive testing of structural lumber. Forest Products Journal. 15(3): 93–101.
- Riggio, M.; Piazza, M. 2011. Stress wave tomography for the analysis of structural timber: Limits, applications, possible combinations with other analysis techniques. In: Proceedings, 17th international symposium on nondestructive testing and evaluation of wood symposium. Sopron, Hungary: University of West Hungary: 611–615.
- Rinn, F. 2006. Mobile techniques for tree and timber assessment. IUFRO Workshop on Nondestructive Testing of Wood. Harbin, China. August 7–9, 2006 (unpublished presentation, personal communication).
- Ross, R.J.; Brashaw, B.K.; Anderson, S.J. 2012. Use of laser scanning technology to obtain as-built records of historic covered bridges. Res. Paper. FPL-RP-669. Madison, WI: U.S. Department of Agriculture, Forest Service, Forest Products Laboratory: 18 p.
- Soltis, L.A.; Wang, X.; Ross, R.J.; Hunt, M.O. 2002. Vibration testing of timber floor systems. Forest Products Journal. 52(10): 75–81.
- Tomikawa, Y.I.; Arita, K.; Yamada, H. 1990. Nondestructive inspection of wooden poles using ultrasonic computed tomography. IEEE Transactions UFFC. 33(4): 354–358.
- Wang, X.; Allison, R.B. 2007. Decay detection in red oak trees using a combination of visual inspection, acoustic testing, and resistance microdrilling. Journal of Arboric Urban Forestry. 34(1):1–4.
- Wang, X.; Wacker, J.P. 2006. Condition assessment of main structural members of the U.S. Brig Niagara. Inspection report, NRRI/TR-2006/25. Duluth, MN: University of Minnesota: 61 p.
- Wang, X.; Divos, F.; Pilon, C.; Brashaw, B.K.; Ross, R.J.; Pellerin, R.F. 2004. Assessment of decay in standing timber using stress wave timing non-destructive evaluation tools—A guide for use and interpretation. Gen. Tech. Rep. FPL-GTR-147. Madison, WI: U.S. Department of Agriculture, Forest Service, Forest Products Laboratory: 12 p.
- Wang, X.; Wacker, J.P.; Morison, A.M.; Forsman, J.W.; Erickson, J.R.; Ross, R.J. 2005. Nondestructive assessment of single-span timber bridges using a vibration-based method. Research Paper FPL-RP-627. Madison, WI: U.S. Department of Agriculture, Forest Service, Forest Products Laboratory: 15 p.
- Wang, X.; Wiedenbeck, J.; Liang, S. 2009. Acoustic tomography for decay detection in black cherry trees. Wood and Fiber Science. 41(2):127–137.
- Yu, Z.; Zhang, S.; Li, H.; Liu, X. 2009. Impulse stress wave tomography for inspecting wood components of ancient wood structures. In: Proceedings, 16th International Symposium on Nondestructive Testing and Evaluation of Wood. Beijing, China: Beijing Forestry University: 169–173.





# Post-Fire Assessment of Structural Wood Members

Robert H. White  
Brian M. Kukay

Because the interior of a charred wood member normally retains its structural integrity, large structural wood members often do not need to be replaced after a fire. Engineering judgment is required to determine which members can remain and which members need to be replaced or repaired. The lack of established methods to directly determine residual capacity of damaged wood members dictates a systematic approach, starting with assessment of likely fire exposure. Assessment includes visual inspection of damaged members, visual inspection of connections, and visual inspection of any protective membranes (such as gypsum board). Potential methods for nondestructive evaluation of structural properties of a fire-damaged wood member are discussed after a brief review of the degradation of wood when exposed to fire.

## Thermal Degradation of Wood

Wood degrades when exposed to elevated temperatures. Fire exposure causes thermal degradation or pyrolysis of wood whereby the wood is converted to volatile gases and a char residue. The extent of any thermal degradation depends on both temperature and duration of exposure. A temperature of  $\approx 300^\circ\text{C}$  ( $\approx 550^\circ\text{F}$ ) is commonly associated with the base of the char layer for wood subjected to direct fire exposure in the standard fire-resistance test (ASTM E 119). Vigorous production of flammable volatiles occurs in the temperature range of  $300$  to  $450^\circ\text{C}$  ( $550$  to  $842^\circ\text{F}$ ). Temperatures below a threshold of  $300^\circ\text{C}$  can still have a demonstrated detrimental effect on wood. The *National Design Specification for Wood Construction* (NDS) indicates that properties of wood heated to  $150^\circ\text{F}$  ( $66^\circ\text{C}$ ) for brief periods will essentially return to their original levels when the wood is cooled (AWC 2012). However, prolonged exposure to temperatures above  $66^\circ\text{C}$  may result in a permanent loss in properties (Kretschmann 2010). The change in residual strength properties of similarly sized individual wood members can differ at elevated temperatures, depending, in part, on how they are loaded. For example, permanent loss in compressive strength has been shown to occur at higher temperatures than a comparative loss in tensile strength (Schaffer 1977).

Kinetic parameters are used to model rate of thermal degradation. Detailed discussions of the processes involved can

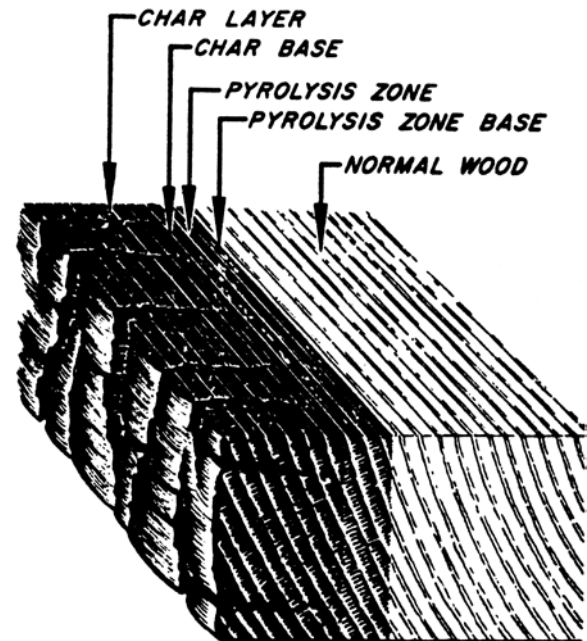
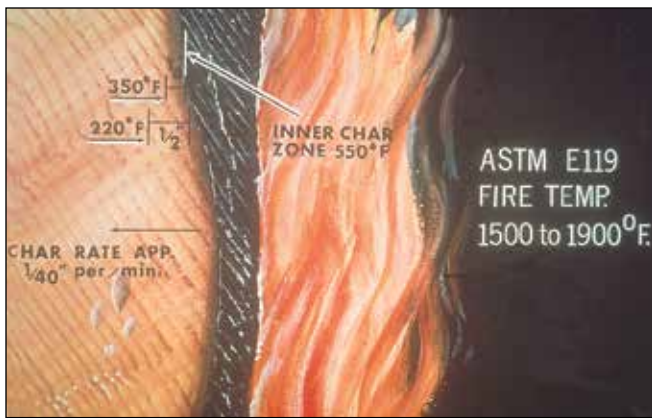


Figure 5.1—Degradation zones in a charred piece of wood.

be found in the literature (Browne 1958, White and Dietsberger 2001). Degradation resulting in weight loss is associated with temperatures exceeding  $100^\circ\text{C}$ . For temperatures less than  $200^\circ\text{C}$  ( $\approx 392^\circ\text{F}$ ), charring of wood requires prolonged exposure. Significant degradation occurs in the temperature range of  $200$  to  $300^\circ\text{C}$  ( $392$  to  $572^\circ\text{F}$ ). Products such as plywood and particleboard have ignition properties very similar to those of solid wood, so the solid wood results will generally be applicable to them. Piloted ignition at heat fluxes sufficient to cause a direct-flaming ignition normally occurs at surface temperatures of  $300$  to  $365^\circ\text{C}$  (Babrauskas 2001). Sudden surface heating of a wood member in a fire results in surface charring and a steep temperature gradient. Thus, the stages of thermal wood degradation previously discussed become zones of degradation in a structural wood member exposed to fire. In a broad sense, there is an outer char layer, a pyrolysis zone, a zone of elevated temperatures, and the cool interior (Fig. 5.1). These zones of degradation reflect the temperature profile through the cross section.



**Figure 5.2—Charring wood member exposed to the standard fire exposure of 815 to 1,038 °C.**

## Fire-Damaged Wood

For wood members that have charred, the char layer can be scraped off. Obviously, any charred portion of a fire-exposed wood member has no residual load capacity. The wood beneath the char layer has residual load capacity, but this residual capacity will be less than the load capacity prior to the fire because of the reduced cross section. Members that have only visual smoke damage or slight browning of the surface also have significant residual load capacity.

ASTM E 119 (ASTM 2009) standard test method is the test for determining the fire-resistance rating of a structural member or assemblies for building code purposes. This severe and direct fire exposure results in rapid surface charring, the development of a char layer with a base temperature of ~300 °C (~550 °F), and a steep temperature gradient of 177 °C (350 °F) at 6 mm (0.2 in.) and 104 °C (220 °F) at 13 mm (0.5 in.) beneath the char layer (Fig. 5.2). The standard fire exposure is a specified time–temperature curve of 538 °C (1,000 °F) at 5 min, 843 °C (1,550 °F) at 30 min, and 927 °C (1,700 °F) at 1 h. For a large wood member directly exposed to the standard fire exposure, the char rate is approximately 0.6 mm/min (38 mm/h, 1.5 in/h, 1/40 in/min). Char rate in the standard test depends on species, density, moisture content, and duration of exposure (White and Nordheim 1992). Most research on fire endurance of wood members has been directed toward predicting or understanding their performance in this test (White 2008, Buchanan 2001). Fire endurance research on wood for other fire exposures or post-fire situations is limited.

Without extinguishment, a fire has three phases:

1. Growth of the fire from ignition to flashover
2. Fully developed post-flashover fire
3. Decay period of declining temperatures as fuel is consumed

Although fire exposure transitions through three phases, the fire exposure of the standard fire-resistance test approximates only the second phase, or post-flashover portion, of the fire. Information gathered in a NFPA 921 investigation will help establish likely maximum temperatures in various locations. The fire exposure of a standard fire-resistance test, such as ASTM E 119 (ASTM 2009), is used to approximate the second phase, or post-flashover portion, of the fire of structural members and assemblies that are in the immediate vicinity. Standard fire exposure represents exposure of a structural member or assembly in the immediate vicinity of a fully developed post-flashover fire. Flashover is the full involvement of combustible contents of the compartment and is associated with flames coming out the door in the standard room-corner test. The following situations are all examples of fire exposures inconsistent with an assumption of the standard fire exposure:

- Exposure of wood components a distance away from the fully developed post-flashover fire (such as roof rafters exposed to hot gases from a fire in a room below)
- Smoldering cellulosic insulation fire near wood rafters
- High-intensity fire that is quickly extinguished
- Prolonged heating of wood after extinguishment
- Wood behind gypsum wallboard or other protective membranes

It is advisable to first obtain an informed understanding of the fire itself and the fire exposure to the structural members being evaluated. The general rules for reducing the cross section for a fire equivalent to the standard exposure are based on assumptions of temperature gradients within uncharred wood during the fire.

## Fire Investigation

As noted by Buchanan (2001), it is valuable to visit the fire scene immediately after the fire to make notes of all of the damage that occurred. The post-fire situation after the mid-1990s fire in a building at the USDA Forest Service, Forest Products Laboratory, is illustrated in Figure 5.3. For most fire investigations conducted by fire departments and other investigators, the intent is to establish the cause for initial ignition and fire growth. The standard guide for such investigations is NFPA 921 *Guide for Fire and Explosions Investigations* (NFPA 2008). This guide advocates a methodology based on a systematic approach and attention to all relevant details. For the purpose of a post-fire assessment of structural wood members, the intent of an immediate investigation is to better estimate the intensity and duration of fire exposure to wood members during and after the fire. Such insight will be helpful in making engineering judgments on likely temperatures within the charred and uncharred wood members. NFPA 921 provides information on various observations for estimating temperatures developed during a fire.



**Figure 5.3—Area of fire origin in Building 2 fire at the Forest Products Laboratory.**

For post-fire assessment, exposure of structural wood members to elevated temperatures during the decay period of fire development should be considered. Although temperatures are lower during the decay period, duration of exposure can be prolonged compared with the duration of the fully developed post-flashover fire phase. The steep temperature gradient near fire-exposed surfaces assumed in normal assessment of residual load capacity is based on transient heating coupled with progressive charring of the wood cross section. During prolonged cooling, surface temperatures will decline while temperatures on the cool inside portion of the cross section will increase. Tests have indicated that this temperature increase in the interior of a wood member due to redistribution of heat after fire exposure is particularly the case for wood protected with gypsum board. Because the decay or post-extinguishment period is one of reduced temperatures, many damage observations made at the fire scene will be less helpful in determining intensity and duration of the exposure. More careful and detailed inspections of structural members and connections will likely need to be done in a subsequent inspection when the general debris has been removed.

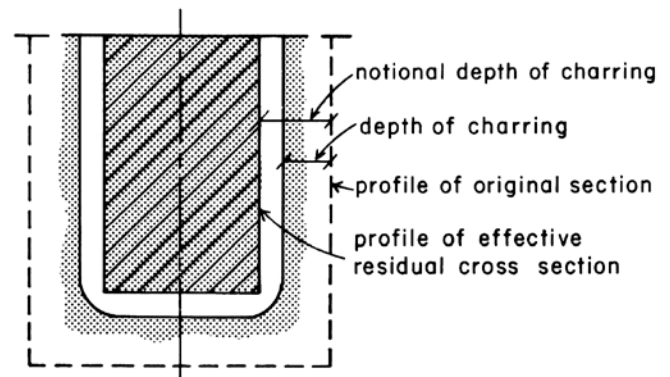
## Visual Inspection of Charred Members

Wood exposed to temperatures in excess of  $\sim 300\text{ }^{\circ}\text{C}$  ( $\sim 550\text{ }^{\circ}\text{F}$ ) will form a residual char layer on the surface (Fig. 5.4). With prolonged exposure, charring of wood can occur at lower temperatures. Although it retains the anatomical structure of uncharred wood, the char layer can be scraped or sand-blasted off.

In an inspection of charred members, it is important to understand that the char layer exhibits significant shrinkage, resulting in fissures in the char layer. Glowing combustion of char also can occur. As a result, thickness of the residual



**Figure 5.4—Charred and uncharred wood members in the Building 2 fire at the Forest Products Laboratory.**



**Figure 5.5—Residual cross section of a charred wood member.**

char layer is less than depth of charring (Fig. 5.5). The profile of the original section will need to be determined from construction records or similar uncharred members.

## Load Capacity of Damaged Members

Thermal degradation of wood results in loss of structural properties. Thermal degradation of wood is a kinetic process. Thermal properties of wood result in development of a distinct temperature gradient in a wood member when it is exposed to fire. Thus, loss of structural properties of fire-damaged wood members depends on both temperature within the wood member and duration of the elevated temperatures.

For an exposed wood member large enough that the temperature of its center or back surface has not increased, the temperature gradient within a wood beam or column for standard fire exposure has been documented. For such a fire exposure, the base of the char layer has a clear

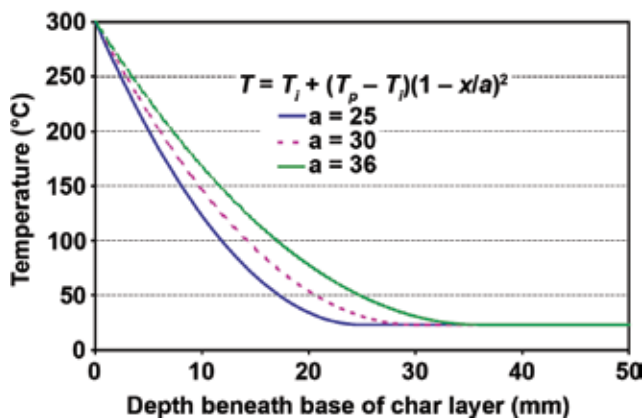


Figure 5.6—Temperature profile beneath the base of the char layer of a semi-infinite wood slab directly exposed to the ASTM E 119 standard fire exposure.

demarcation. For standard fire exposure of a semi-infinite slab, the temperature profile beneath the base of the char layer can be approximated by

$$T = T_i + (T_p - T_i)(1 - x/a)^2 \quad (5.1)$$

where  $T_i$  is initial temperature of the wood (°C),  $T_p$  is temperature of the base of the char layer (300 °C),  $x$  is distance beneath the char layer (mm), and  $a$  is thickness (mm) of the layer of elevated temperatures (Fig. 5.6).

For the data of White and Nordheim (1992), the average value of  $a$  was 33 mm (1.3 in.) for the eight species tested (Janssens and White 1994). An alternative exponential model was developed by Schaffer (1965, 1982b). This temperature profile is valid after a standard fire exposure of about 20 min. The thickness of the zone of elevated temperatures decreases for increased fire exposure severity. For a char depth of 12 mm (0.5 in.), the observed depth of elevated temperatures decreased from 36 to 30 mm (1.4 to 1.2 in.) when the level of a constant heat flux exposure was increased from 15 to 50 kW/m<sup>2</sup> (White and Tran 1996). For a char depth of 6 mm (0.2 in.), the depths of elevated temperature were 34 and 25 mm (1.3 and 1.0 in.) for heat flux levels of 15 and 50 kW/m<sup>2</sup>, respectively.

The irreversible effects of elevated temperatures on mechanical properties depend on moisture content, heating medium, temperature, exposure period, and to some extent species and size of the piece involved (Kretschmann 2010). Over a period of months, temperatures of 66 °C (150 °F) can significantly reduce modulus of rupture (MOR). Graphs of the permanent effect of oven heating for periods up to 200 days on MOR and modulus of elasticity (MOE) can be found in the *Wood Handbook* (Kretschmann 2010). After 50 days of oven heating at 115 °C (240 °F), MOR at room temperature was approximately 90% that of unheated controls. For samples heated at 135 °C (275 °F), MOR at room temperature was approximately 62% that of unheated controls after 50 days. Permanent losses in strength occurred more rapidly

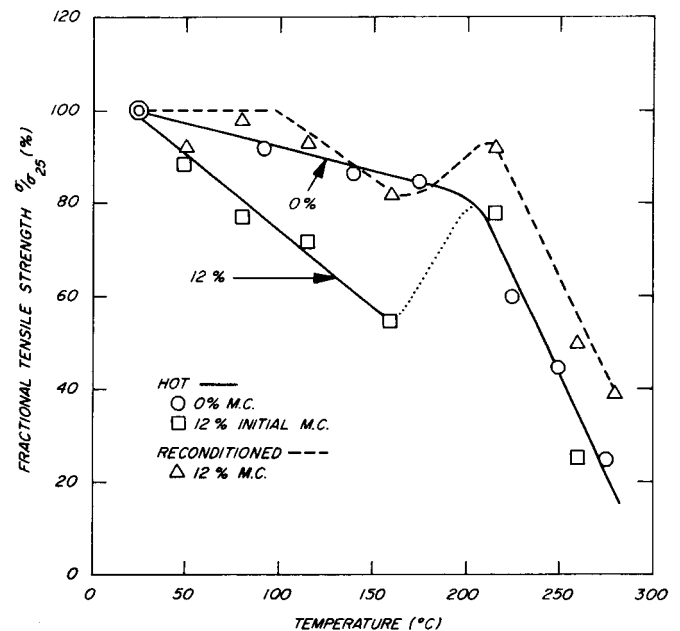
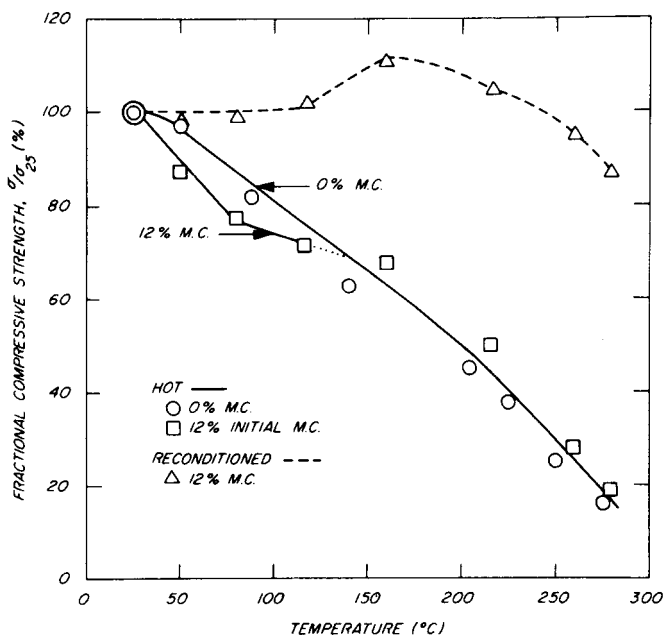


Figure 5.7—Fractional tensile strength as function of temperature (Schaffer 1977, 1982b, 1984).

with heating temperatures of 155 °C (310 °F) and 175 °C (350 °F). Elevated temperatures below charring temperature appear to have little effect on MOE.

Using the data of Knudson and Schniewind (1975) and Schaffer (1973), Schaffer (1977, 1982a,b) developed graphs of temperature effects on tensile (Fig. 5.7) and compressive (Fig. 5.8) strength. The data illustrate the reduced impact that temperature has on residual strength properties once the wood has cooled to room temperature and has been reconditioned back to 12% moisture content. At a depth of only 8 mm (0.3 in.) beneath the char layer, temperature has dropped to 200 °C (Fig. 5.6). At 200 °C, residual strength properties still exceed 80% of initial room temperature values (Figs. 5.7 and 5.8). Additional information on the effects of temperature and moisture content on strength properties of wood are provided by Schaffer (1982a), Gerhards (1982), Kretschmann (2010), and Buchanan (2001). During an actual fire, the residual capacity of the wood member is affected by steam generated within the member (Buchanan 2001) and zones of elevated moisture content (White and Schaffer 1980). Schaffer (1982a) concluded his discussion of properties of timbers exposed to fire by noting that because of the short time that wood just beyond the char line has been at its maximum temperature, overall strength loss in heavy sections will be small and residual load-carrying capacity will be closely approximated by using the initial strength properties of the uncharred residual cross section as a base.

Thus, the steep temperature gradient allows us to easily estimate residual load capacity of the member by reducing residual cross section of the uncharred section by an additional amount to improve the safety margins of our



**Figure 5.8—Fractional compressive strength as function of temperature (Schaffer 1982a,b).**

calculations. In general, fire endurance design of wood members is referred to as the reduced or effective cross-section method (Fig. 5.5). A notional char depth defines the effective cross section for calculation purposes. Although visual char depths may provide some insight, depth of char and overall damage can make predicting a time of exposure to fire from the char characteristics difficult (Schroeder 1999). In their model of a large glued-laminated member in a fire, Schaffer et al. (1986) calculated a reduction of 8 mm (0.3 in.) for tensile strength loss. In the U.S. procedure for fire endurance design of wood members, reduction for load capacity calculations is an additional 20% of the actual depth of charring (AF&PA 2003). For a 1-h fire-resistance test, this calculates to 8 mm (0.3 in.) (char depth of 38 mm (1.5 in.)). Complicating factors, including grain orientation, heat flux exposure, and moisture content, can vary significantly, even within a given species. Accordingly, a uniform char rate cannot always be supported (Schroeder 1999). The AF&PA American Wood Council procedure also uses a nonlinear char rate (White and Nordheim 1992). In calculating the ability of a member to maintain a specified load in a fire test, reduced cross-sectional area is multiplied by ultimate strength properties. This procedure for calculations of fire-resistance ratings is discussed in the *National Design Specification for Wood Construction* (AWC 2012). Increasing the reduction due to charring by 20% is used in the calculations to account for rounding at the corners and reduction of strength and stiffness of the heated zone (AWC 2012).

In calculating residual load capacity of a member after a fire, the reduced cross section would however be multiplied by the allowable stresses as in normal allowable stress

design (AWC 2012). Unless the fire is severe, replacing all the large members after a fire is usually not necessary. Fox (1974) conducted a study using three 50-ft 24F DF stress-grade beams that were salvaged from a warehouse after a severe fire had reduced the cross section of each member by nearly 10%. Two-point loading tests were conducted on each beam after they were cut into six 10-ft sections and three 30-ft sections. Results showed no evidence that the fire had reduced the strength of the beams beyond the reduced cross section and affected glue line (Fox 1974). According to Schaffer (1982a), because of the short time that wood just beyond the char line is at its maximum temperature, overall strength loss in heavy sections will be small and residual load-carrying capacity will be closely approximated by using the initial strength properties of the uncharred residual cross section as a base. Time of exposure and temperature gradient within fire damaged members may, in some instances, warrant a more in-depth analysis by a qualified professional. Using the information of Kukay et al. (2013), four glued-laminated beams were exposed to a time-temperature curve intended to produce a significant zone of damaged wood due to elevated temperatures within the residual wood section. In this instance, loss in strength of the residual section was arrived at through a longer duration and lower temperature fire exposure, with a more gradual temperature gradient within the fire damaged member. Results show that relative changes in apparent MOE and MOR changed by 20% and 46%, respectively, on average after the beams had been fire damaged in comparison to a control group that was not fire damaged. This marked decrease in flexural properties goes beyond simply reducing cross section once the char layer has been removed for members that can otherwise be expected to remain in service (Kukay et al. 2013).

Any assessment of a glued-laminated beam must take into account the grade of the individual laminates. This is particularly the case for beams with a high-grade tension laminate that likely was subjected to the most charring. In his discussion of assessment and repair of fire-damaged buildings, Buchanan (2001) notes that residual wood under the charred layer of heavy timber structural members can be assumed to have full strength. He continues with the comment that the size of the residual cross section can be determined by scraping away the charred layer and any wood which is significantly discolored. Williamson (1982a) recommends that the amount of char/wood that should be removed by sandblasting or other means should be equal to the char layer plus approximately 6 mm (0.25 in.) or less of the wood below the char-wood interface. The exposed surface should then have the appearance of normal wood. Williamson (1982a) makes a distinction between design capacities controlled by compression strength or stiffness and those controlled by tensile strength. In the compression case, the removal of the additional 6 mm (0.25 in.) of wood is sufficient to use the residual cross section in the design calculations without any additional adjustment. For the case of tensile design calculations, Williamson (1982a)

recommends an additional adjustment beyond the removal of 6 mm (0.25 in.) of wood. In calculations of residual tensile strength of the member, basic allowable design stress values should be reduced by 10%. An alternative is to take a reduction of 16 mm (0.625 in.) of wood beyond the char-wood interface and use 100% of the basic allowable design stress values.

In 1970, the glulam industry adopted the use of high-quality tension laminations based on research conducted at FPL. If a glulam bending member manufactured after that date is damaged during a fire and the outermost tension lamination is destroyed, the allowable bending stress for the remaining cross section must be reduced by 25%. This is in addition to the reduction in section size.

Removal or degradation of any wood from a structural member will likely require regrading of the member to determine the proper allowable properties to be used in calculations of residual load capacity. Wood members should be re-graded after the char is completely removed. The grade of the structural member may have changed due to loss of the outer layer of wood. Charring of the wood member is similar to ripping the wood member with a saw in terms of its impact on mechanical properties and grade of the member. Grading procedures take into account the impact of residual dimensions on applicable grading rules for the reduced dimension as well as the altered relative locations of strength-reducing characteristics (such as knots) in the cross section. Current accredited grading agencies are listed in a document of the American Lumber Standard Committee (ALSC 2011). Inherently, wood is a natural product and no two samples are exactly alike. Variability is introduced naturally as well as mechanically, and through manufacturing and construction practices (Garab et al. 2010). Calculation of residual load capacity must take into account structural grade variation of individual components within a composite structural wood member. This is very important for charred glued-laminated (glulam) structural members, because glulam members are normally manufactured with a graded lay-up that has higher grade materials at the outer laminates and lower grade materials in the core. In particular, the charred bottom laminate may have been a high-grade tension laminate that significantly impacts the bending strength of the member. Examples of calculations for fire-damaged glulam members are provided by Williamson (1982a). Williamson (1982b) also discusses the rehabilitation of fire-damaged heavy timbers at the Filene Center for Performing Arts at Wolftrap Farm, Virginia. The structure was damaged due to a fire while the facility was under construction in 1971.

White and Woeste (2013) point out that often in older buildings, timbers are not grade marked and there are no records of any grading of timbers. They recommend steps for analysis begin with a paper study that will either warrant if further study is required or simply necessitate that a member be replaced outright. When additional study is required, calculations are further refined and incorporate a cohort of

field measurements up to and including identification and documentation of the species, grade, and size of each timber. Additional considerations are presented in Kukay et al. (2012).

## Light-Frame Members

Most information on fire-damaged wood focuses on evaluation of large timber members. Evaluation of residual load capacity of structural elements in light-frame construction does not allow some of the assumptions of the previous analysis, such as direct fire exposure and semi-infinite slab.

Wood structural members in light-frame construction are generally covered by a membrane of gypsum board. Gypsum board provides very effective fire protection. Gypsum is primarily hydrated calcium sulfate. Bound water within the gypsum board delays the rise of the temperature at the wood–gypsum board interface above 100 °C (212 °F) for a significant period of time. The chemically bound water is released as steam during this calcination process. Gypsum board loses its integrity or cohesion after exposure to fire (Cramer et al. 2003). The integrity of the gypsum board can be examined by using a sharp blade or by removing samples for more careful examination. Spizman (1994) suggests grinding a sample of the gypsum (minus the paper) and moistening it with water to a paste-like material. If, after 2 h, the sample is hard, similar to plaster of Paris, it should be considered heat damaged. As with fire-damaged wood, similar materials in areas not involved in the fire provide a performance level for comparison. A rule of thumb is that gypsum board may be assumed to retain its integrity as long as the paper envelope has not charred (King 2002). The cross section of the gypsum board can be examined for visual evidence of the progression of calcination through the gypsum board. Where there is evidence of fire damage, the gypsum board may need to be removed so that structural wood members can be examined. Charring of wood is more likely to occur at the joints between sheets of gypsum board. Because of protection provided to the sides of the wood members, damage to structural members in assemblies with cavity insulation may be limited.

In light-frame construction, significantly charred members are generally removed (Steven Winters Associates, Inc. 1999). Application of the guidelines for heavy timbers to light-frame construction results in inadequate load capacity with even a small amount of charring. However, many light-frame members in an actual fire suffer only smoke damage or very superficial charring. Given the high temperature of a fire and the low temperature for wood char (300 °C (550 °F)), superficial charring reflects very brief exposure to a fire. As previously discussed, the depth of elevated temperatures is less for initially smaller depths of charring. Charring is much more rapid during initial charring. As the thickness of the insulative char layer increases, the progression of charring is slowed. It has also been shown that as density of a wood species increases, charring rate decreases (Yang et al. 2009). Even so, once the temperature

at the center of the light-frame member starts to increase, the temperature profile shown in Figure 5.6 is not valid and temperatures will increase more rapidly. King (2002) states that structural repair of fire-damaged framing is often not required if char depth is less than 6 mm (0.2 in.). He also notes that treatment of any significant loss of surface should have approval of a local building inspector or a qualified structural engineer. Other rules of thumb that have been recommended for lumber in trusses include (1) no charring, (2) charring of up to 10% of the cross section, and (3) charring depth up to 1.6 mm (1/16 in.) (Smith 2000). Engineering judgment on whether a member needs to be replaced includes considering the importance of the member to the structural integrity of the building and the need for a conservative approach.

Light-frame construction contains numerous building cavities. When fire damage is not extensive, heat, smoke, and water damage can occur within the building cavities. In a cavity, fire-generated heat damage would involve components with higher sensitivities than the surrounding materials (King 2002). In addition to the cavities of structural components, many cavities are also associated with the routing of utilities in the building.

## Testing

Unlike wood damaged by decay, little work has been done on suitable methods for field testing fire-damaged wood for residual load capacity. Some potential options are those suggested for field testing fire-retardant-treated (FRT) plywood for possible thermal degradation (NAHB 1990). Prolonged elevated temperatures, associated with roof applications, have resulted in degradation of plywood treated with some formulations of fire-retardant treatments. Thermal degradation of plywood was similar to degradation of wood in a fire. The National Association of Home Builders (NAHB) identified several options for possible degraded FRT plywood:

1. Applying a concentrated proof load
2. Removing small samples for laboratory mechanical testing
3. Screw withdrawal test
4. Chemical analysis for chemical composition of the wood, such as hemicelluloses
5. Spectral analysis for end products of degradation

Options 1 and 2 are destructive if, for example, the proof load exceeds the linear elastic range for the component being tested, thereby reducing its cross-sectional integrity as a result (option 1), or if the removal of small specimens from the full-size member renders it unrepairable or otherwise requires that it be replaced (option 2). The need to classify wood by evaluating the change in physical and mechanical properties of small clear specimens can be very valuable where similar members are exposed to various degrees of degradation and are otherwise expected to remain in service.

It is also noted that the moisture content is an underlying factor of wood strength that can readily be verified by the use of a moisture meter during a post-fire investigation. However, immediately following a fire, moisture content of charred members is likely to fall below 6.5%, a value associated with the lower limit of most moisture meters. Generally speaking, a 1% change in moisture content can affect wood strength properties by as much as 2% to 6% (Regents of the University of Minnesota and the Forest Products Management Development Institute 1998). Typically, wood gains strength as moisture content decreases. Wood will gain back moisture and re-equilibrate after heat damage. As such, lasting effects of this nature would occur only if the equilibrium moisture content associated with a given relative humidity changed. This type of test has been standardized and is facilitated with the use of equations presented in ASTM D 4933-99 (ASTM 2004). For these reasons, when comparing strength properties from separate members to one another, the pretesting moisture content of each beam must be less than 16% and adjusted to a standard moisture content of 12% according to ASTM D 2915-03 (ASTM 2003). Additional information on temperature and moisture content effects on strength properties of wood in general are provided by Kretschmann (2010).

Research results have supported the use of Options 2 and 3 when establishing the change in residual flexural properties for fire-damaged members that are otherwise expected to remain in service (Kukay et al. 2012). Evidence of changes in flexural properties can be obtained from static bending tests that are performed on small samples or from screw withdrawal tests (along with other significant factors). Either methodology provides a more quantitative approach than simply replacing individual members, presuming that depthwise reductions are less than 0.25 in. These methodologies are thought to be valid when similar members of like size are heat damaged in similar fashion.

Kukay and Todd (2009) developed equations including variables for moisture content (MC), specific gravity (SG), moment of inertia (I), maximum screw withdrawal load (SW), cross-sectional orientation with respect to the pith (O), treatment group (T, charred or uncharred), and various interactions between these variables. The following reduced model was found to be adequate based on a model comparison *F*-test procedure:

$$Y = \beta_0 + \beta_1 MC + \beta_2 SG + \beta_3 I + \beta_4 SW + \beta_5 O + \beta_6 T + \beta_7 O \cdot T + \varepsilon$$

where the  $\beta_i$ 's are regression parameters and  $\varepsilon$  represents experimental error. Essentially this inclusive model represents the parameters that were (through this particular study) associated with either residual stiffness or residual strength. So depending on which one *Y* represents, the factors used to predict that value change.

Models like this are believed to be applicable under similar field conditions and are methodology-, material-, and grade-specific. Rather than predicting specific values of  $E_T$  and

MOR, results obtained through screw-withdrawal tests are best represented when the results are compared with those of similar members that have obvious degrees of residual load capacity. Variability of results stems from changes in predrilled pilot-hole size, screw insertion depth, screw tip to screw shank diameter, and rate of extraction. For these reasons, care was needed when interpreting and extrapolating the results from screw-withdrawal tests. General correlations are likely to lack adequate precision to establish actual property values. Results of individual research studies that incorporate screw-withdrawal tests are generally not extrapolated. Additional work is needed to expand the models to account for the effects of a wider range of species and grades of materials. Additional information can be found in Kukay and Todd (2009).

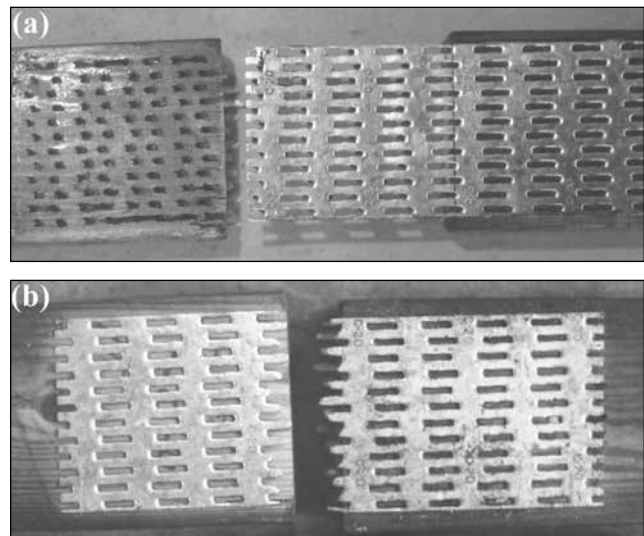
In the case of options 3 and 4, further research is needed to identify and document any appropriate correlations and methodologies for fire-damaged wood. Because general correlations are likely to lack adequate precision to establish actual property values, these options are more likely to be fruitful when they are used to compare similar members in the fire-damaged building that have obvious degrees of degradation or residual load capacity. Thus, they may be more useful in evaluating fire damage in light-frame construction.

Application of a screw-withdrawal test to the FRT plywood situation was investigated by Winandy et al. (1998). In their study, the variability and reproducibility of 8-mm (5/16-in.) screw insertion was compared with that for 16-mm (5/8-in.) screw insertion in 16-mm (5/8-in.) plywood. The shorter depth measurements were observed to have higher coefficients of variation. In many instances, load cell resolution of the apparatus exceeded 25% of the measured value compared with less than 10% for the 16-mm (5/8-in.) screw. Although there may have been some gradient in the FRT-plywood degradation through the thickness of the plywood, the application of the method to fire-damaged wood would need to be able to identify degradation primarily near the surface of the uncharred wood.

Research has been done on modeling strength loss in wood by chemical composition (Winandy and Lebow 2001). Potentially, an increment borer could be used to extract wood samples for chemical or spectral analysis. Spectral analysis tests use infrared radiation to identify end products of chemical processes. A trained organic chemist is required to interpret the data gained from a spectrophotometer. More information pertaining to spectral analysis is discussed by APA (1989).

## Connections

All connections will require detailed inspection to assess their load-bearing capacity. In his discussion of large fire-damaged timbers, Williamson (1982a) notes that the effect of fire on the strength of any connection is very difficult to determine without a thorough investigation of the affected



**Figures 5.9—(a) Test specimens of metal plate connections illustrating charred wood failure beneath the plate, and (b) metal plate failure with uncharred wood beneath the plate.**

connection, because the amount of damage is dependent on the quantity of metal and the surface contact of metal with fire along with other factors. There may also be possible chemical damage from the corrosive effects of fire residues. Metal roof supports, ceilings, and other structural members are vulnerable to long-term acid attack from fire residues (King 2002). Exposed metal connections provide a means for heat conduction into the wood (Fuller et al. 1992).

Degradation of the wood beneath a metal plate connection is what results in its failure (Fig. 5.9a). In a situation when heating is strictly via radiation, the metal plate may actually initially protect the wood beneath the plate from charring as much as the adjacent wood (Fig. 5.9b). The test specimens shown in Figure 5.9 are from a project to develop a fire endurance model for metal-plate-connected wood trusses (White et al. 1993, Shrestha et al. 1995). If there is damage to the plate area, the plate is discolored, or there is charring under the plate, it is recommended that the connection be considered ineffective (Smith 2000).

## Smoke Damage

The subjects of smoke damage and control of odor are not within the scope of this manual. The impact of fire residues on wood framing is confined to appearance and odor (King 2002). Except for possible corrosive effects on metal fasteners, smoke and other fire residues do not affect the load capacity of the wood member. The National Institute of Disaster Restoration (NIDR) provides guidelines based on current practice in restoration technology (King 2002). The institute is associated with the Association of Specialists in Cleansing and Restoration ([www.ascr.org](http://www.ascr.org)). Actions for addressing smoke damage are also discussed in an article by the Chicora Foundation (2003).



Fire odors should be identified and removed before any application of sealers, paints, or other finishes because the masking effects of such products are temporary (King 2002). The presence of fire acids, visible fire residues, and odor need to be addressed. The NIDR *Guidelines for Fire and Smoke Repair* (King 2002) provides information on methods for removal of fire residues, neutralizing acid residues, removing fire odors, and the use of sealing and encapsulation. Structural members restored after fire damage should retain no char or untreated fire residues even when they are covered with new framing or other interior finishes (King 2002).

## Repairs

Once the load capacities of fire-damaged members are determined, potential repairs can be identified. When blasting is required, various media can be used, including sand, ground corn cob, and baking soda. Once char and other fire residues have been removed, wood surfaces can be treated for residual odors and sealers can be applied.

Information on rehabilitation of damaged structures is available in the nine-volume series of the PATH program ([www.pathnet.org](http://www.pathnet.org)) of the U.S. Department of Housing and Urban Development known as *The Rehab Guide*. Information on moisture damage will help address water damage due to fire suppression efforts. With the high level of concern about mold damage, any moisture damage associated with fire suppression also needs to be addressed. Restoration of wood floors is discussed by King (2002).

In the case of partially fire-damaged wood, repairs often consist of reinforcing the original damaged member by attaching a supplemental piece of wood to it. This action is referred to as “sistering.” The effect of fire on epoxy-repaired timber is discussed by Avent and Issa (1984). They found the two epoxies they tested to be sensitive to heat at relatively low temperature (66 to 93 °C (150 to 200 °F)). Buchanan and Barber (1994) found the two epoxies they tested lost strength rapidly at 50 °C (122 °F). Epoxy joints should be protected by a thick outer wood layer or other protective material such as gypsum board. Available information indicates that adhesives (phenol, resorcinol, and melamine) normally used in the manufacture of structural wood composites have a fire performance equivalent of solid wood. Schaffer (1968) found that separation did not occur at either phenol-resorcinol or melamine glue lines in either charred or noncharred laminates during fire exposure.

Any repairs should also include the consideration of design changes or additional protection to reduce the likelihood of future fire damage. Schaffer (1982c) discusses designing to avoid problems with fire. Because of concerns about the fire-resistance performance of some adhesives being used to make finger-jointed lumber, the wood industry established performance qualifications, and the “HRA” markings for

end-jointed lumber are interchangeable with solid-sawn lumber in 1-h fire-rated assemblies (AF&PA 2007). Additional information can be found in the *Wood Handbook* (White and Dietenberger 2010). Repairs must comply with appropriate building code requirements. Conventional repair methods may increase dead loads, installation costs, and transportation expenses because of heavier reinforcement materials. Modern reinforcement methods using fiber-reinforced polymers (FRP) have lower strength-to-weight and stiffness ratios. This allows FRPs to be used without a significant increase to the dead load of a structure.

FRP composites are usually bonded to the higher stress zone, more commonly known as the tension side of timber beams, which increases their load-carrying capabilities while decreasing deflection. FRP composites bonded on the tension face are either adhered to the surface as a sheet or are inserted into a cut narrow groove and secured into place with a bonding agent. Near-surface mounting of FRP bars placed in cut grooves is a new technology designed to increase the load-carrying capacity and energy absorption capacity comparatively (Kim and Harries 2010). Installing the bars in a cut groove on the tension side of the members means that repairs will typically be hidden from view. This is very important to historic covered bridges that need to maintain their historic integrity and charm.

Glass-fiber reinforced plastic (GFRP) bars are generally less expensive than other FRP bars, carbon fiber, and aramid fiber, but still significantly improve the load-carrying capacity and stiffness of a member (Raftery et al. 2009).

It should be mentioned that for all cases of FRP bar installed into timber, the bond shear-slip between the two materials has a minor effect on ultimate loading capacity of the members. During analysis, a continuous bond between the two materials was observed in most of the tested cases (Valipour and Crews, 2011).

## Concluding Remarks

Often, the end product of the reaction of wood to fire is an outer char layer and a cooler inner core of solid wood. In many fires, there is a clear demarcation between the char layer and the relatively undamaged residual wood. With appropriate analysis, treatment, and repairs, the fire-damaged wood members often can be restored instead of being replaced (Fig. 5.10).

## References

- AF&PA. 2003. Calculating the fire resistance of exposed wood members. Technical Report 10. Washington, DC: American Forest & Paper Association. ([www.awc.org](http://www.awc.org)).
- AF&PA. 2007. Adhesive awareness guide. Washington, DC: American Forest & Paper Association, 9 p. ([www.wood-aware.info](http://www.wood-aware.info))



**Figure 5.10—Post-fire inspection (top) of residence; post-fire (middle) and post-repair (bottom) of Building 2 at the Forest Products Laboratory. Top photo courtesy Montana Standard; [www.mtstandard.com](http://www.mtstandard.com).**

ALSC. 2011. [List of grading agency names and addresses]. Germantown, MD: American Lumber Standard Committee, Incorporated. ([http://www.alsc.org/greenbook%20collection/LumberProgram\\_facsimile.pdf](http://www.alsc.org/greenbook%20collection/LumberProgram_facsimile.pdf))

APA. 1989. Fire-retardant-treated plywood roof sheeting: in-situ testing. Tacoma, WA: American Plywood Association.

ASTM. 2003. Standard practice for evaluating allowable properties for grades of structural lumber. Designation D 2915-03. West Conshohocken, PA: ASTM International.

ASTM. 2004 (reapproved). Standard guide for moisture conditioning of wood and wood-based materials. Designation D 4933-99. West Conshohocken, PA: ASTM International.

ASTM. 2009. Standard test methods for fire tests of building construction and materials. Designation E 119-09b. West Conshohocken, PA: ASTM International.

Avent, R.R.; Issa, C.A. 1984. Effect of fire on epoxy-repaired timber. *Journal of Structural Engineering*. 110(12): 2858–2875.

AWC. 2012. Commentary: National design specification (NDS) for wood construction with commentary ASD/LRFD, 2012 Edition. Washington D.C.: American Wood Council.

Babrauskas, V. 2001. Ignition of wood: a review of the state of the art. London: Interflam, Interscience Communications Ltd.: 71–88.

Browne, F.L. 1958. Theories of the combustion of wood and its control. FPL Report 2136. Madison, WI: U.S. Department of Agriculture, Forest Service, Forest Products Laboratory.

Buchanan, Andrew H. 2001. Structural design for fire safety. New York: John Wiley & Sons, Ltd.

Buchanan, A.; Barber, D. 1994. Fire resistance of epoxied steel rods in glulam timber. *In: Proceedings, volume 1, Pacific timber engineering conference*. Queensland, Australia: Timber Research and Development Advisory Council: 590–598.

Chicora Foundation, Inc. 2003. What is smoke? Columbia, SC: Chicora Foundation, Inc. ([www.chicora.org/fire.htm](http://www.chicora.org/fire.htm)).

Cramer, S.M.; Sriprutkiat, G.; White, R.H. 2003. Engineering analysis of gypsum board ceiling membranes at elevated temperatures. *In: Proceedings of designing structures for fire*. Bethesda, MD: Society of Fire Protection Engineers: 173–182.

Fox, S.P. 1974. Residual strength of fire-damaged laminated beams. *Forest Products Journal*. 24(1): 48–50.

Fuller, J.J.; Leichti, R.J.; White, R.H. 1992. Temperature distribution in a nailed gypsum-stud joint exposed to fire. *Fire and Materials*. 16: 95–99.

Garab, J.; Toth, A.; Szalai, J.; Bejo, L.; Divos, F. 2010. Evaluating glued laminated beams using a nondestructive testing technique. *Transactions of FAMENA*. 34(4): 33–46.

Gerhards, C.C. 1982. Effect of moisture content and temperature on the mechanical properties of wood: An analysis of immediate effects. *Wood and Fiber*. 14(1): 4–36.

Janssens, M.L.; White, R.H. 1994. Temperatures profiles in wood members exposed to fire. *Fire and Materials*. 18: 263–265.

Kim, Y.J.; Harries, K.A. 2010. Modeling of timber beams strengthened with various CFRP composites. *Engineering Structures*. 32(10): 3225–3234. doi:10.1016/j.engstruct.2010.06.011

- King, M.L. 2002. NIDR guidelines for fire and smoke damage repair. Millersville, MD: The National Institute of Disaster Restoration. 153 p.
- Knudsen, R.M.; Schniewind, A.P. 1975. Performance of structural wood members exposed to fire. *Forest Products Journal*. 25(2):23–32.
- Kretschmann, D.E. 2010. Mechanical properties of wood. In: *Wood handbook, wood as an engineering material*. Gen. Tech. Report FPL-GTR-190, Madison, WI: U.S. Department of Agriculture, Forest Service, Forest Products Laboratory: 5-1–5-46.
- Kukay, B.M.; Todd, C. 2009. Determining wood's residual flexural properties using nondestructive testing. *Wood Design Focus*. 19(2): 8–12.
- Kukay, B.M.; White, R.H.; Woeste, F. 2011. Fire damage of wood structures. In: *Inspection testing and monitoring of buildings and bridges*. Washington, DC: International Code Council and National Council of Structural Engineers Associations. Chapter 6.
- Kukay, B.M.; White, R.H.; Todd, C.S.; Jahn, T. 2013. Evaluating fire damaged components of timber bridges and structures. In: *Proceedings, 2013 ASCE structures congress*. Reston, VA: American Society of Civil Engineers.
- NAHB. 1990. Homebuilders guide to fire retardant treated plywood: Evaluation, testing and replacement. Upper Marlboro, MD: National Association of Home Builders National Research Center. 49 p.
- NFPA. 2008. Guide for fire and explosion investigations. NFPA 921. Quincy, MA: National Fire Protection Association. 305 p.
- Raftery, G.M.; Harte, A.M.; Rodd, P.D. 2009. Bond quality at the FRP wood interface using wood-laminating adhesives. *International Journal of Adhesion and Adhesives*. 29(2): 101–110. doi:10.1016/j.ijadhadh.2008.01.006
- Regents of the University of Minnesota and the Forest Products Management Development Institute. 1998. The nature of wood and wood products, a self-study educational CD-ROM. Minneapolis, MN: University of Minnesota.
- Schaffer, E.L. 1965. An approach to the mathematical prediction of temperature rise within a semi-infinite wood slab subjected to high-temperature conditions. *Pyrodynamics*. 2:117–132.
- Schaffer, E.L. 1968. A simplified test for adhesive behavior in wood sections exposed to fire. Res. Note FPL-0175. Madison, WI: U.S. Department of Agriculture, Forest Service, Forest Products Laboratory.
- Schaffer, E.L. 1973. Effect of pyrolytic temperatures on the longitudinal strength of dry Douglas-fir. *ASTM Journal of Testing and Evaluation*. 1(4):319–329.
- Schaffer, E. 1977. State of structural timber fire endurance. *Wood and Fiber*. 9(2):145–170.
- Schaffer, E.L. 1982a. 2.3 Temperature of Chapter 2 Factors which influence serviceability of wood structures. In: *Evaluation, maintenance and upgrading of wood structures—A guide and commentary*. New York: American Society of Civil Engineers: 69–92.
- Schaffer, E.L. 1982b. 2.7 Fire of Chapter 2 Factors which influence serviceability of wood structures. In: *Evaluation, maintenance and upgrading of wood structures—A guide and commentary*. New York: American Society of Civil Engineers: 120–126.
- Schaffer, E.L. 1982c. 7.4 Fire of Chapter 7 Designing to avoid problems. In: *Evaluation, maintenance and upgrading of wood structures—A guide and commentary*. New York: American Society of Civil Engineers: 319–338.
- Schaffer, E.L.; Marx, C.M.; Bender, D.A.; Woeste, F.E. 1986. Strength validation and fire endurance of glued-laminated timber beams. Res. Pap. FPL-467. Madison, WI: U.S. Department of Agriculture, Forest Service, Forest Products Laboratory.
- Schroeder, R.A. 1999. Post-fire analysis of construction materials. PhD Dissertation. Berkeley, CA: University of California.
- Shrestha, D.; Cramer, S.M.; White, R.H. 1995. Simplified models for the properties of dimension lumber and metal plate connections at elevated temperatures. *Forest Products Journal*. 45(7/8): 35–42.
- Smith, R. 2000. Frequently asked questions—fire damaged trusses. *Structural Building Components Magazine*. August 2000. ([www.sbcmag.info/sites/sbcmag.info/files/Archive/2000/aug/0008%20FAQ.pdf](http://www.sbcmag.info/sites/sbcmag.info/files/Archive/2000/aug/0008%20FAQ.pdf))
- Spizman, I. 1994. Gypsum wallboard vs. fire and smoke. *Cleaning and Restoration*. May: 18.
- Steven Winter Associates, Inc. 1999. Partitions, ceilings, floors & stairs. Volume 5 of the Rehab Guide. Washington, DC: U.S. Department of Housing and Urban Development, Office of Policy Development and Research. ([www.pathnet.org](http://www.pathnet.org)).
- Valipour, H.R.; Crews, K. 2011. Efficient finite element modeling of timber beams strengthened with bonded fiber reinforced polymers. *Construction and Building Materials*. 25(8): 3291–3300. doi:10.1016/j.conbuildmat.2011.03.017.
- White, R.H. 2008. Analytical methods for determining fire resistance of timber members. In: *SFPE handbook of fire protection engineering, fourth edition, section 4, chapter 11* Quincy, MA: National Fire Protection Association: 4-346–4-366.

White, R.H.; Dietenberger, M.A. 2001. Wood products: Thermal degradation and fire. In: Encyclopedia of materials: Science and technology. New York: Elsevier Science Ltd.

White, R.H.; Dietenberger, M.A. 2010. Fire safety of wood construction. In: Wood handbook, wood as an engineering material. Gen. Tech. Report FPL-GTR-190, Madison, WI: U.S. Department of Agriculture, Forest Service, Forest Products Laboratory: 18-1-18-22.

White, R.H.; Nordheim; E.V. 1992. Charring rate of wood for ASTM E-119 exposure. *Fire Technology*. 28(1): 5–30.

White, R.H.; Schaffer; E.L. 1980. Transient moisture gradient in fire-exposed wood slab. *Wood and Fiber*. 13(1): 17–38.

White, R.H.; Tran, H.C. 1996. Charring rate of wood exposed to a constant flux. In: Proceedings of Wood and Fire Safety Conference. Zvolen, Slovak Republic: Technical University Zvolen.

White, R.H.; Woeste, F. 2013. Post-fire analysis of solid-sawn heavy beams. *Structure Magazine*. November 2013.

White, R.H.; Cramer, S.M.; Shrestha, D.K. 1993. Fire endurance model for a metal-plate-connect wood truss. Res. Pap. FPL-RP-522. Madison, WI: U.S. Department of Agriculture, Forest Service, Forest Products Laboratory. 12 p.

Williamson, T.G. 1982a. 4.5.4 Rehabilitation of fire-damaged members. In: Evaluation, maintenance and upgrading of wood structures—A guide and commentary, chapter 4. New York: American Society of Civil Engineers: 172–178.

Williamson, T.G. 1982b. 8.8 Rehabilitation of fire-damaged timber—The Filene Center. In: Evaluation, maintenance and upgrading of wood structures—A guide and commentary, Chapter 8. New York: American Society of Civil Engineers: 417–422.

Winandy, J.E.; Lebow, P.K. 2001. Modeling strength loss in wood by chemical composition: Part I, An individual component model for southern pine. *Wood and Fiber Science*. 33(2): 239–254.

Winandy, J.E.; Lebow, P.K.; Nelson, W. 1998. Predicting bending strength of fire-retardant-treated plywood from screw-withdrawal tests. Res. Pap. FPL-RP-568. Madison, WI: U.S. Department of Agriculture, Forest Service, Forest Products Laboratory. 20 p.

Yang, T.; Wang, S.; Tsai, M.; Lin, C. 2009. The charring depth and charring rate of glued laminated timber after a standard fire exposure test. *Building and Environment*. 44(2): 231–236. doi:10.1016/j.buildenv.2008.02.010.

# Estimation of Design Values for In-Service Wood

David Kretschmann

When a new structure is constructed a structural engineer relies on current design values for a known species and local building codes to determine the appropriate size and grade of timber required for particular service loads. The strength of timber found in historic structures can vary considerably because of age and condition. Uncertainty can also be introduced when estimating strength of members if the species and grade are unknown. Many historic wooden structures were constructed before standardized grading practices for timbers were agreed upon. For evaluation purposes, design value estimates for existing wood members must be assigned with as much accuracy as possible. This is impossible when the type, grade, and condition of the existing wood are uncertain. The current practice for wood in service in historical structures is to assign values for strength and moduli from existing specifications based on assumed species and grade, but often these assumptions are inaccurate for the specific conditions and can result in an unreliable assessment of the structure. The condition assessment of a structure can be a complicated process and, even with the best available information, estimation of allowable properties of members can require considerable engineering judgment. With accurate information, an engineer or other professional can make determinations about maintenance, repair, restoration, or decommissioning of the structure. An inspecting engineer must take three critical steps to estimate design values for wood members: (1) identify the species of wood, (2) estimate a size and grade for the member (Fig. 6.1), and (3) determine the condition of the wood in the member (described in detail in Chapters 1–5). If accurate information is not available, historic structures may be prematurely replaced.

The continued use of a structure is dependent on an affirmation that it meets appropriate strength thresholds given its intended use. Because this directly affects public safety, every step in the process of making a design value estimate must be performed with care, precision, and a robust understanding of the factors that affect it. This chapter discusses each step of the process that leads to a design value estimate—wood species identification, member grading, on-site condition assessment, and calculating an appropriate strength—with a high degree of detail. The content will also empower the reader to make a judgment about the advisability of securing the services of a consulting

engineer. It is best to engage a skilled and experienced inspector familiar with wood identification, timber grading, and condition assessment. The reader will be able to more easily communicate with them about the problems and concerns found in the structure.

The scope of this chapter is limited to visually graded structural lumber. It does not address the assignment of design values for structural composite lumber products, glued-laminated timbers, or mechanically graded structural lumber.

## Significance of Species

The first and probably most critical step to accurately assign design values to in-service members is identifying the species of wood in the member. Wood properties for clear wood vary considerably from species to species, as illustrated by selected examples in Table 6.1 (FPL 2010). Values reported in Table 6.1 are average measured properties of small clear specimens in a laboratory setting and are not design values. Proper identification of wood species is a skill that requires a considerable amount of training and experience to become proficient at sorting through wood features and characteristics. In most cases it is best if the services of a professional are utilized to identify the species of wood. Chapters 1–8 of Wiedenhoft and Kretschmann (2014) detail the features, skills, and characters used to make a field identification of wooden members likely to be found in wooden bridges in the United States; this detailed description is also applicable to wooden members in historic structures. Regardless of who conducts the identification, following are some useful tips for sampling and prioritization of woods species samples.

## Sampling of Members

The best advice that can be given for sampling members is “have a plan.” With photos or hand drawings, establish a system for identifying, cataloging, and recording property estimates for the members. Different species can be used for different sections of the structure; therefore, the ability to trace the location to positions on the structure is very important. An inspector must also consider which members should be prioritized, which can be accomplished by preliminary structural analysis to save time and effort in the field.

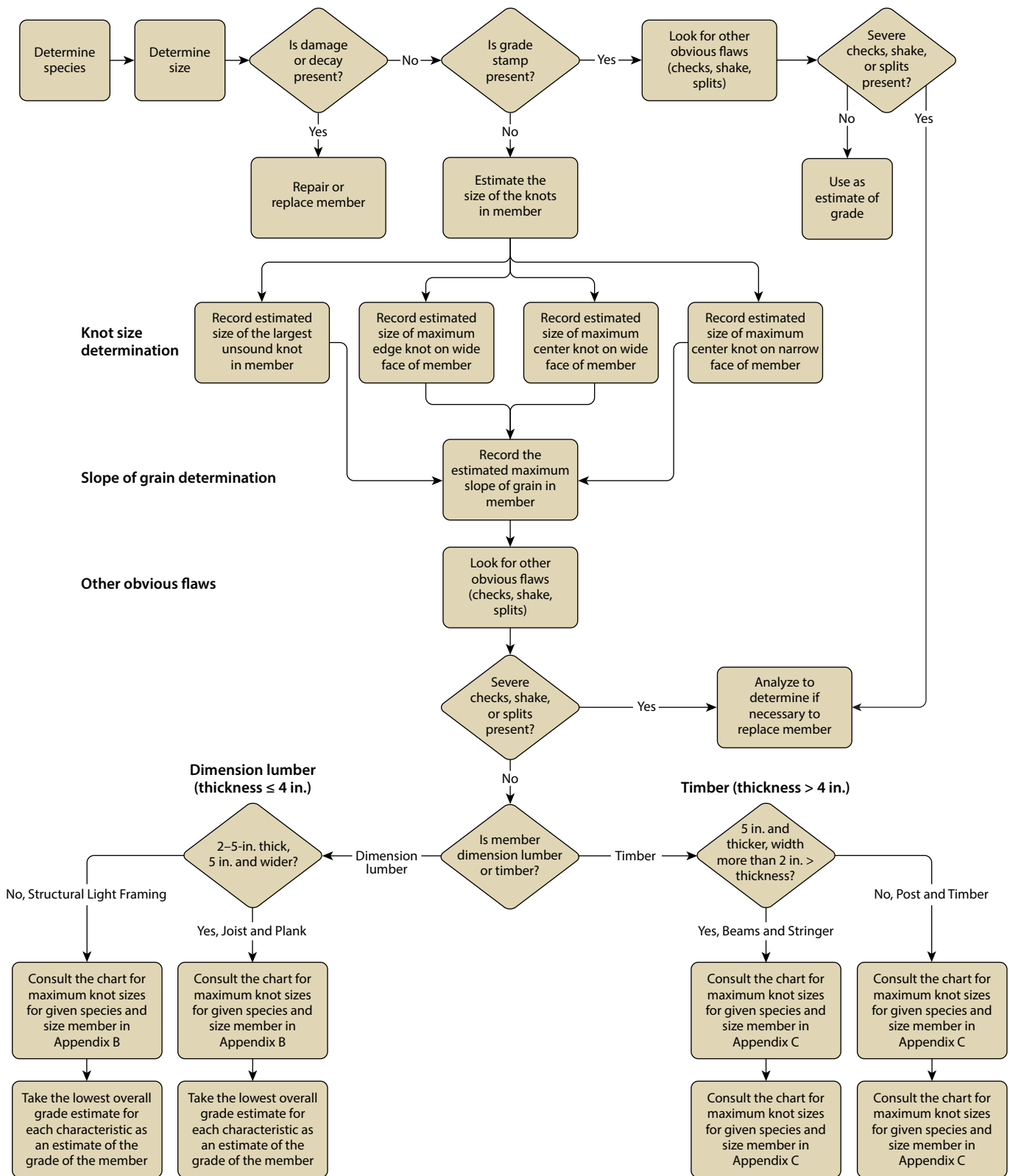


Figure 6.1—Steps for member grading.

**Table 6.1—Strength properties of some commercially important woods grown in the United States (metric)<sup>a</sup>**  
**(These values are average measured properties of small clear specimens in a laboratory setting and are not design values)**

Common species names	Mois- ture content	Specific gravity <sup>b</sup>	Static bending			Impact bending (mm)	Com- pression parallel to grain (kPa)	Compres- sion per- pendicular to grain (kPa)	Shear paral- lel to grain (kPa)	Tension perpen- dicular to grain (kPa)	Side hard- ness (N)
			Modulus of rupture (kPa)	Modu- lus of elas- ticity <sup>c</sup> (MPa)	Work to maxi- mum load (kJ/m <sup>3</sup> )						
Hardwoods											
Ash, White	Green	0.55	66,000	9,900	108	970	27,500	4,600	9,300	4,100	4,300
	12%	0.60	106,000	12,000	115	1,090	51,100	8,000	13,200	6,500	5,900
Aspen, Quaking	Green	0.35	35,000	5,900	44	560	14,800	1,200	4,600	1,600	1,300
	12%	0.38	58,000	8,100	52	530	29,300	2,600	5,900	1,800	1,600
Beech, American	Green	0.56	59,000	9,500	82	1,090	24,500	3,700	8,900	5,000	3,800
	12%	0.64	103,000	11,900	104	1,040	50,300	7,000	13,900	7,000	5,800
Birch, Yellow	Green	0.55	57,000	10,300	111	1,220	23,300	3,000	7,700	3,000	3,600
	12%	0.62	114,000	13,900	143	1,400	56,300	6,700	13,000	6,300	5,600
Chestnut, American	Green	0.40	39,000	6,400	48	610	17,000	2,100	5,500	3,000	1,900
	12%	0.43	59,000	8,500	45	480	36,700	4,300	7,400	3,200	2,400
Elm, American	Green	0.46	50,000	7,700	81	970	20,100	2,500	6,900	4,100	2,800
	12%	0.50	81,000	9,200	90	990	38,100	4,800	10,400	4,600	3,700
Elm, Rock	Green	0.57	66,000	8,200	137	1,370	26,100	4,200	8,800	—	—
	12%	0.63	102,000	10,600	132	1,420	48,600	8,500	13,200	—	—
Hickory, Shagbark	Green	0.64	76,000	10,800	163	1,880	31,600	5,800	10,500	—	6,500
	12%	0.72	139,000	14,900	178	1,700	63,500	12,100	16,800	—	8,400
Maple, Red	Green	0.49	53,000	9,600	79	810	2,260	2,800	7,900	—	3,100
	12%	0.54	92,000	11,300	86	810	45,100	6,900	12,800	—	4,200
Maple, Sugar	Green	0.56	65,000	10,700	92	1020	27,700	4,400	10,100	—	4,300
	12%	0.63	109,000	12,600	114	990	54,000	10,100	16,100	—	6,400
Oak, Northern Red	Green	0.56	57,000	9,300	91	1,120	23,700	4,200	8,300	5,200	4,400
	12%	0.63	99,000	12,500	100	1,090	46,600	7,000	12,300	5,500	5,700
Oak, Southern Red	Green	0.52	48,000	7,900	55	740	20,900	3,800	6,400	3,300	3,800
	12%	0.59	75,000	10,300	65	660	42,000	6,000	9,600	3,500	4,700
Oak, White	Green	0.60	57,000	8,600	80	1,070	24,500	4,600	8,600	5,300	4,700
	12%	0.68	105,000	12,300	102	940	51,300	7,400	13,800	5,500	6,000
Sycamore, American	Green	0.46	45,000	7,300	52	660	20,100	2,500	6,900	4,300	2,700
	12%	0.49	69,000	9,800	59	660	37,100	4,800	10,100	5,000	3,400
Yellow-poplar	Green	0.40	41,000	8,400	52	660	18,300	1,900	5,400	3,500	2,000
	12%	0.42	70,000	10,900	61	610	38,200	3,400	8,200	3,700	2,400

**Table 6.1—Strength properties of some commercially important woods grown in the United States (metric)<sup>a</sup>—con. (These values are average measured properties of small clear specimens in a laboratory setting and are not design values)**

Common species names	Moisture content	Specific gravity <sup>b</sup>	Static bending			Impact bending (mm)	Compression parallel to grain (kPa)	Compression perpendicular to grain (kPa)	Shear parallel to grain (kPa)	Tension perpendicular to grain (kPa)	Side hardness (N)
			Modulus of rupture (kPa)	Modulus of elasticity <sup>c</sup> (MPa)	Work to maximum load (kJ/m <sup>3</sup> )						
Softwoods											
Baldcypress	Green	0.42	46,000	8,100	46	640	24,700	2,800	6,500	2,100	1,700
	12%	0.46	73,000	9,900	57	610	43,900	5,000	6,900	1,900	2,300
Cedar, Western	Green	0.31	35,900	6,500	34	430	19,100	1,700	5,300	1,600	1,200
	12%	0.32	51,700	7,700	40	430	31,400	3,200	6,800	1,500	1,600
Douglas-fir, Coast	Green	0.45	53,000	10,800	52	660	26,100	2,600	6,200	2,100	2,200
	12%	0.48	85,000	13,400	68	790	49,900	5,500	7,800	2,300	3,200
Fir, Balsam	Green	0.33	38,000	8,600	32	410	18,100	1,300	4,600	1,200	1,300
	12%	0.35	63,000	10,000	35	510	36,400	2,800	6,500	1,200	1,700
Fir, Noble	Green	0.37	43,000	9,500	41	480	20,800	1,900	5,500	1,600	1,300
	12%	0.39	74,000	11,900	61	580	42,100	3,600	7,200	1,500	1,800
Hemlock, Eastern	Green	0.38	44,000	7,400	46	530	21,200	2,500	5,900	1,600	1,800
	12%	0.40	61,000	8,300	47	530	37,300	4,500	7,300	—	2,200
Hemlock, Western	Green	0.42	46,000	9,000	48	560	23,200	1,900	5,900	2,000	1,800
	12%	0.45	78,000	11,300	57	580	49,000	3,800	8,600	2,300	2,400
Larch, Western	Green	0.48	53,000	10,100	71	740	25,900	2,800	6,000	2,300	2,300
	12%	0.52	90,000	12,900	87	890	52,500	6,400	9,400	3,000	3,700
Pine, Eastern White	Green	0.34	34,000	6,800	36	430	16,800	1,500	4,700	1,700	1,300
	12%	0.35	59,000	8,500	47	460	33,100	3,000	6,200	2,100	1,700
Pine, Jack	Green	0.40	41,000	7,400	50	660	20,300	2,100	5,200	2,500	1,800
	12%	0.43	68,000	9,300	57	690	39,000	4,000	8,100	2,900	2,500
Pine, Loblolly	Green	0.47	50,000	9,700	57	760	24,200	2,700	5,900	1,800	2,000
	12%	0.51	88,000	12,300	72	760	49,200	5,400	9,600	3,200	3,100
Pine, Lodgepole	Green	0.38	38,000	7,400	39	510	18,000	1,700	4,700	1,500	1,500
	12%	0.41	65,000	9,200	47	510	37,000	4,200	6,100	2,000	2,100
Pine, Longleaf	Green	0.54	59,000	11,000	61	890	29,800	3,300	7,200	2,300	2,600
	12%	0.59	100,000	13,700	81	860	58,400	6,600	10,400	3,200	3,900
Pine, Ponderosa	Green	0.38	35,000	6,900	36	530	16,900	1,900	4,800	2,100	1,400
	12%	0.40	65,000	8,900	49	480	36,700	4,000	7,800	2,900	2,000
Pine, Red	Green	0.41	40,000	8,800	42	660	18,800	1,800	4,800	2,100	1,500
	12%	0.46	76,000	11,200	68	660	41,900	4,100	4,800	3,200	2,500
Spruce, Red	Green	0.37	41,000	9,200	48	460	18,800	1,800	5,200	1,500	1,600
	12%	0.40	74,000	11,400	58	640	38,200	3,800	8,900	2,400	2,200
Spruce, Sitka	Green	0.37	39,000	5,800	43	610	18,400	1,900	5,200	1,700	1,600
	12%	0.40	70,000	10,800	65	640	38,700	4,000	7,900	2,600	2,300

<sup>a</sup>Results of tests on clear specimens in the green and air-dried conditions. These values are average measured properties of small clear specimens in a laboratory setting and are not design values. Definition of properties: impact bending is height of drop that causes complete failure, using 0.71-kg (50-lb) hammer; compression parallel to grain is also called maximum crushing strength; compression perpendicular to grain is fiber stress at proportional limit; shear is maximum shearing strength; tension is maximum tensile strength; and side hardness is hardness measured when load is perpendicular to grain.

<sup>b</sup>Specific gravity is based on weight when oven-dry and volume when green or at 12% moisture content.

<sup>c</sup>Modulus of elasticity measured from a simply supported, center-loaded beam, on a span depth ratio of 14/1. To correct for shear deflection, the modulus can be increased by 10%.



## What to Prioritize in Sampling for Wood Identification

As is often the case with inspections, limited time and resources are available. The inspector should prioritize the members that are most critical to structural performance. The species of wood in these members should be the first to be identified.

## How to Collect Samples for Wood Identification

Samples can be obtained by coring a member, drilling with a hole saw, or collecting broken splinters. Each sample should be gathered in individual containers and labeled so that samples can be traced back to the members they came from. A large enough sample must be taken so that sample preparation techniques can be safely applied, but it should not be taken in a way that affects structural integrity of the member.

## How Many Samples to Take

It may be likely that the same species would be used for most members. However, a sufficient number of samples should be taken to ensure that species involved in the most critical structural members are thoroughly represented. A minimum of 20% of those members should be sampled for identification. Approximately 10% of the other less critical structural members should also be sampled for identification.

## Size of Member

Before an estimated grade can be assigned to a particular member, the size of that member must be accurately estimated. If you are inspecting a structure that was built or refurbished since 1970, you will be able to directly use much of the information tabulated in the current NIST Product Standard PS 20 related to size (Table 6.2, DOC [current edition], Smith and Wood 1964). Wood members are divided into three categories: boards, dimension lumber, and timbers. Structural members are classified as either dimension lumber or timbers. Most historic structures, however, were built before current methods assigning design values to structural wood members were standardized. Sizes of members likely will not be the standard sizes you are accustomed to today.

A piece of “dimension lumber” is any structural lumber that has a nominal thickness of 2 to 4 in. (actual thickness of 38 to 114 mm (1.5 to 4.5 in.)). A piece of “timber” is a structural member that has a nominal thickness greater than 5 in. (actual thickness greater than 114 mm (4.5 in.)). Timbers are further subdivided, based on use, into subcategories of “Beam and Stringer” (timbers used as bending members) and “Post and Timber” (timbers used more as compression and tension members). The size of a member directly influences the capacity of the member and will help determine which design values for “dimension lumber or timbers” should be associated with it.

All three dimensions of a lumber member need to be determined (Fig. 6.2). The thickness of a member is the measured dimension of the narrower face of a rectangular piece of lumber. The width of the member is the measured dimension of the larger face of a rectangular piece of lumber. The length of the member is the measured dimension of the largest dimension of the member. Measurement is best accomplished using digital calipers and measuring tapes on exposed cross sections of members. Some more creative means are often required to determine sizes of less accessible members.

## Grade of Member

An estimate of grade will be required for an inspector to initially estimate design values for a member. Unfortunately, estimating grade for an inspector is an imprecise business that requires a great deal of judgment. The information in this section is meant to provide a very basic overview of grading and allow crude judgments on the grade of members. Becoming proficient in visual grading requires many hours of experience. Some basic understanding of the grading process will allow an inspector to judge whether a more thorough grading of members is advised. Experienced certified graders should be hired to provide the truest estimate of grade for members.

## Purpose of Grading

To more efficiently and economically use wood from logs, pieces of wood of similar mechanical properties are placed in categories called stress grades, which are characterized by (a) one or more sorting criteria, (b) a set of properties for engineering design, and (c) a unique grade name. With new material, a grade stamp on a piece of lumber tells architects, engineers, builders, and building officials the quality of a piece of lumber. A typical grade stamp for dimension lumber is shown in Figure 6.3. A grade stamp provides information on the supervising grading agency (WWPA 2005), the wood species or species combination (Douglas-fir–Larch), the mill number or brand of the firm that produced the board (12), the grade requirements the piece meets (No. 1 and better), and the target moisture content to which the wood was dried or the moisture content at which it was surfaced (surfaced-green). If a grade stamp is present, the inspector’s job is immediately made easier. A certified grader has already judged the grade of the member based on the most severe defects present. If the inspector determines that the member is still undamaged and undecayed, this grade can be used to determine the design values. If not, additional judgments on the quality of the member must be made.

## Brief History of Visual Grading

For many years, lumber has demonstrated the versatility of wood by serving as a primary raw material for construction and manufacture in the United States. In this role, lumber has been produced in a wide variety of products from many different species. The first industry-sponsored grading rules

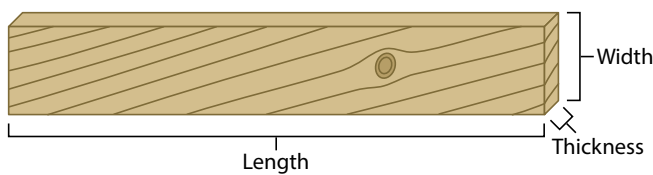
**Table 6.2—Specifications for dimension of structural members (DOC PS 20)**

Thicknesses					Widths				
Minimum dressed					Minimum dressed				
Nominal in.	Dry		Green		Nominal in.	Dry		Green	
	mm	in.	mm	in.		mm	in.	mm	in.
Board									
					2	38	1-1/2	40	1-9/16
					3	64	2-1/2	65	2-9/16
					4	89	3-1/2	90	3-9/16
3/8	8	5/16	9	11/32	5	114	4-1/2	117	4-5/8
1/2	11	7/16	12	15/32	6	140	5-1/2	143	5-5/8
5/8	14	9/16	15	19/32	7	165	6-1/2	168	6-5/8
3/4	16	5/8	17	11/16	8	184	7-1/4	190	7-1/2
1	19	3/4	20	25/32	9	210	8-1/4	216	8-1/2
1-1/4	25	1	26	1-1/32	10	235	9-1/4	241	9-1/2
1-1/2	32	1-1/4	33	1-9/32	11	260	10-1/4	267	10-1/2
					12	286	11-1/4	292	11-1/2
					14	337	13-1/4	343	13-1/2
					16	387	15-1/4	394	15-1/2
Dimension									
					2	38	1-1/2	40	1-9/16
					2-1/2	51	2	52	2-1/16
					3	64	2-1/2	65	2-9/16
2	38	1-1/2	40	1-9/16	3-1/2	76	3	78	3-1/16
2-1/2	51	2	52	2-1/16	4	89	3-1/2	90	3-9/16
3	64	2-1/2	65	2-9/16	4-1/2	102	4	103	4-1/16
3-1/2	76	3	78	3-1/16	5	114	4-1/2	117	4-5/8
4	89	3-1/2	90	3-9/16	6	140	5-1/2	143	5-5/8
4-1/2	102	4	103	4-1/16	8	184	7-1/4	190	7-1/2
					10	235	9-1/4	241	9-1/2
					12	286	11-1/4	292	11-1/2
					14	337	13-1/4	343	13-1/2
					16	387	15-1/4	394	15-1/2
Timbers									
5 & 6 thick	13 off	1/2 off	13 off	1/2 off	5 & 6 wide	13 off	1/2 off	13 off	1/2 off
7–15 thick	19 off	3/4 off	13 off	1/2 off	7–15 wide	19 off	3/4 off	13 off	1/2 off
≥ 16 thick	25 off	1 off	13 off	1/2 off	≥ 16 wide	25 off	1 off	13 off	1/2 off

(product descriptions) for softwoods, which were established before 1900, were comparatively simple because sawmills marketed their lumber locally and grades had only local significance. As new timber sources across the United States were developed and lumber was transported to distant points, each producing region continued to establish its own grading rules. Lumber from various regions differed in

size, grade name, and allowable grade characteristics. When different species were graded under different rules and competed in the same markets, confusion and dissatisfaction were inevitable.

Research conducted on wood properties in the early 1900s had two distinct camps: full-size testing and small clear wood testing. The full-size testing group felt that testing



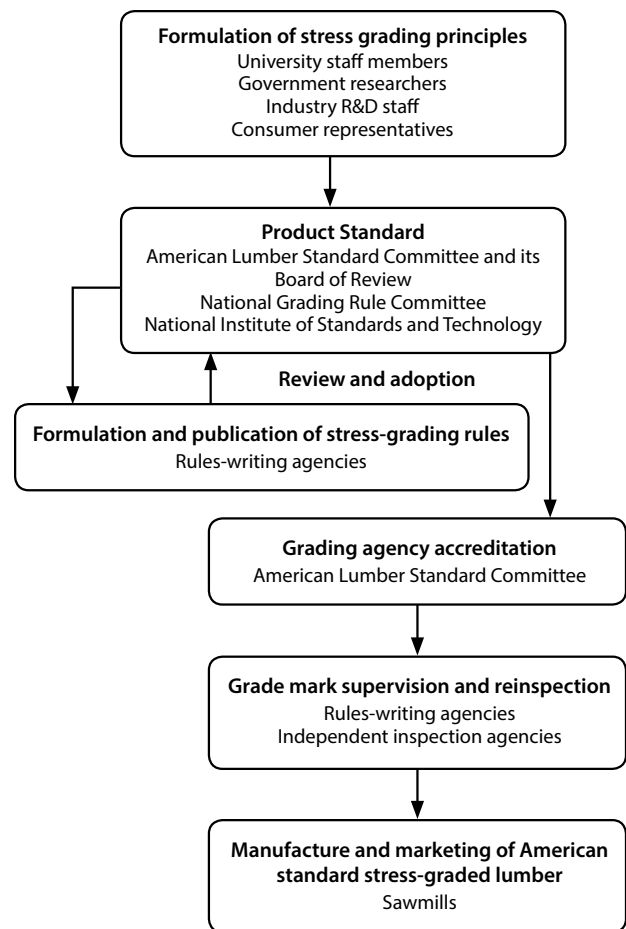
**Figure 6.2—Definition of length, width, and thickness in a lumber member.**



**Figure 6.3—Grade stamp from WWP No. 1 & Better dimension lumber. Moisture content is surfaced green (unseasoned) condition, over 19% (WWPA 2005).**

programs and any subsequent grading standards should be done on full-size members available to consumers. This group argued that this approach would reduce the waste involved in overbuilt structures and ensure minimum standards for integrity and safety. The small clear wood group, primarily foresters, felt that timber tests should focus on the qualities of trees rather than the potential design uses for lumber. Their group argued that tests of multiple small samples of clear wood should be conducted to provide strength averages without incurring the expenses and waste that full-size testing would generate (Green and Evans 2001). This debate continues to this day.

As grading rules began to develop, a number of conferences were sponsored by the U.S. Department of Commerce from 1919 to 1925 to minimize unnecessary differences in grading rules and to improve and simplify these rules. These conferences were attended by representatives of lumber manufacturers, distributors, wholesalers, retailers, engineers, architects, and contractors. The result of these conferences was a relative standardization of sizes, definitions, and procedures for deriving allowable design properties and a voluntary American Lumber Standard. Two Circulars, Circular 295, “Basic Grading Rules and Working Stresses for Structural Timbers,” and Circular 296, “Standard Grading Specifications for Yard Lumber,” involving allowable design values published by USDA Forest Products Laboratory in 1923, served as the basis for the grading rules we see in the United States today (Newlin and Johnson 1923, Ivory et al. 1923). In the years that followed initial acceptance of the first grading rules, these rules have been modified as more information was gathered on the influence of knots, slope of grain, growth characteristics, and sawing practices.



**Figure 6.4—Voluntary system of responsibilities for stress grading under the American Softwood Lumber Standard.**

An orderly, voluntary, but circuitous system of responsibilities has evolved in the United States for the development, manufacture, and merchandizing of most stress-graded lumber (Fig. 6.4). Stress-grading principles are developed from research findings and engineering concepts, often within committees and subcommittees of ASTM International (formerly the American Society for Testing and Materials), and then applied to product classes. Lumber cannot be graded as American Standard lumber unless the grade rules have been approved by the American Lumber Standard Committee (ALSC), Inc., Board of Review. Virtually all commercial softwood and hardwood lumber used for structural purposes that is manufactured in the United States is stress graded under American Lumber Standard practice and is called American Lumber Standard program lumber. The American Lumber Standard has been modified several times, including the addition of hardwood species to the standard beginning in 1970. The current edition is the American Softwood Lumber Standard PS 20–10. Distinctive grade marks for each species or species grouping are provided by accredited agencies. The principles of stress grading are also applied to

several hardwood species under provisions of the American Softwood Lumber Standard, ASTM International, and then applied to product classes. The allowable design properties are tabulated in the Supplement to the National Design Specification (AWC 2012).

## Responsibilities and Standards for Stress Grading

Organizations that write and publish grading rule books containing stress-grade descriptions are called rules-writing agencies. Grading rules that specify American Softwood Lumber Standard (ALSC) PS 20 must be certified by the ALSC Board of Review for conformance with this standard. Organizations that write grading rules, as well as independent agencies, can be accredited by the ALSC Board of Review to provide grading and grade-marking supervision and re-inspection services to individual lumber manufacturers. Accredited rules-writing and independent agencies are listed below. These agencies are in the business of grading and have a wealth of experience of determining grades of lumber. The continued accreditation of these organizations is under the scrutiny of the ALSC Board of Review. For the most accurate assessment of grade of a member an accredited grader from one of these organizations should be used. (For updated information, contact American Lumber Standard Committee, P.O. Box 210, Germantown, MD 20875; [alsc@alsc.org](mailto:alsc@alsc.org); [www.alsc.org](http://www.alsc.org).)

### *Rules-writing agencies*

Northeastern Lumber Manufacturers Association (NeLMA)  
Northern Softwood Lumber Bureau (NSLB)  
Redwood Inspection Service (RIS)  
Southern Pine Inspection Bureau (SPIB)  
West Coast Lumber Inspection Bureau (WCLIB)  
Western Wood Products Association (WWPA)  
National Lumber Grades Authority (NLGA)

### *Independent agencies*

American Institute of Timber Construction  
Continental Inspection Agency, LLC  
Pacific Lumber Inspection Bureau, Inc.  
Stafford Inspection and Consulting, LLC  
Renewable Resource Associates, Inc.  
Timber Products Inspection  
Alberta Forest Products Association  
Canadian Lumbermen’s Association  
Canadian Mill Services Association  
Canadian Softwood Inspection Agency, Inc.  
Central Forest Products Association  
Council of Forest Industries  
MacDonald Inspection  
Maritime Lumber Bureau  
Newfoundland and Labrador Lumber Producers Association  
Quebec Forest Industry Council

Tables 6.3 to 6.5 provide example grading rules for various grades at the time of this publication. The most current

rules for visually grading lumber and timber members can be obtained from various rules-writing agencies that are responsible for supervising lumber mill grading operations. The most up-to-date set of rules can be obtained from the rules-writing agencies. These rules can provide an inspector with a clear guide as to what is acceptable under current visual grading rules.

## Current Visual Grading System

The grading rules in use today, like those discussed in 1923, are based on the premise that mechanical properties of lumber and timbers differ from mechanical properties of clear wood because many growth characteristics affect properties and these characteristics can be seen and judged visually.

For dimension lumber (lumber less than 90 mm (nominal 4 in.)), a single set of grade names and descriptions is used throughout the United States, although the design values vary with species. The current National Grading Rule restrictions for dimension lumber are given in Table 6.3.

Timbers (lumber standard 114 mm (nominal 5 in.) or more in least dimension) are also structurally graded under ALSC procedures. Unlike grade descriptions for dimension lumber, grade descriptions for structural timbers are not standardized across species. Structural timbers of Southern Pine are graded without regard to anticipated use (Table 6.4). For most species, however, timber grades are classified according to intended use (Table 6.5).

## Influence of Visual Grading Characteristics on Grade

Visual grading characteristics influence wood properties and performance, and as such are used as sorting criteria. Such characteristics include knots, slope of grain, checks and splits, shake, density, decay, heartwood and sapwood, pitch pockets, and wane. To make the most exact estimate of a structural member’s grade, all these characteristics should be considered, but the grade of the member will be determined by the most severe of these characteristics. Not all these member characteristics will be easy or possible to measure in place, but their influence on properties is discussed for completeness. The most critical of these characteristics for inspections are highlighted in a later section (“What to prioritize in field estimation grading”). With some experience, you will be able identify which of the features explained below represent the most significant or severe defect in the member and only measure that feature.

### Knots

Knots are branches or portions of branches embedded in a piece of wood and cause localized cross grain with steep slopes within the timber. A very damaging aspect of knots in sawn lumber is that the continuity of the grain around the knot is interrupted by the sawing process. The location of a knot influences its effect on strength. Centerline knots on the

**Table 6.3—National Grading Rule Specifications for Dimension Lumber (Standard Grading Rules for Southern Pine Lumber 2002; used courtesy of Southern Pine Inspection Bureau)**

Characteristics	Select Structural			No. 1			No. 2			No. 3		
Compression wood	← Not allowed in damaging form for the grade considered →											
Slope of grain	1 in 12			1 in 10			1 in 8			1 in 4		
Decay	Not permitted			Not permitted			Heart center, 1/3 thickness × 1/3 width			Heart center, 1/3 cross section. Must not destroy nailing edge. See para. 710(e).		
Holes	Same as unsound knots			Same as unsound knots			See chart below			See chart below		
Knots	Edge (in.)	Center-line (in.)	Unsound knots (in.)	Edge (in.)	Center-line (in.)	Unsound knots (in.)	Edge (in.)	Center-line (in.)	Holes (in.)	Edge (in.)	Center-line (in.)	Holes (in.)
2×4	3/4	7/8	3/4	1	1-1/2	1	1-1/4	2	1-1/4	1-3/4	2-1/2	1-3/4
2×5	1	1-1/2	7/8	1-1/4	1-7/8	1-1/8	1-5/8	2-3/8	1-3/8	2-1/4	3	1-7/8
2×6	1-1/8	1-7/8	1	1-1/2	2-1/4	1-1/4	1-7/8	2-7/8	1-1/2	2-3/4	3-3/4	2
2×8	1-1/2	2-1/4	1-1/4	2	2-3/4	1-1/2	2-1/2	3-1/2	2	3-1/2	4-1/2	2-1/2
2×10	1-7/8	2-5/8	1-1/4	2-1/2	3-1/4	1-1/2	3-1/4	4-1/4	2-1/2	4-1/2	5-1/2	3
2×12	2-1/4	3	1-1/4	3	3-3/4	1-1/2	3-3/4	4-3/4	3	5-1/2	6-1/2	3-1/2
	Sound, firm, encased, pith, tight and well spaced. One hole or equivalent smaller holes per 4 lin. ft.			Sound, firm, encased, pith, tight and well spaced. One hole or equivalent smaller holes per 3 lin. ft.			Well spaced knots of any quality. One hole or equivalent smaller holes per 2 lin. ft.			Well spaced knots of any quality. One hole or equivalent smaller holes per 1 lin. ft.		
Shakes	← Ends: Same as splits. Elsewhere: 2 ft surface; none through. →						← Ends: Same as splits. Elsewhere: Surface 3 ft or 1/4 length; 2 ft through. →			← 1/6 length if through at edges or ends; elsewhere through shakes 1/3 length. →		
Checks	← Surface seasoning checks not limited. Through checks at ends limited as splits. →											
Skips	← Hit and miss in 10% of the pieces. See para. 720(f). →						← Hit and miss. 5% of pieces may be hit or miss or heavy skip for 2 ft. See para. 720(e,f,g). →			← Hit or miss. 10% of pieces may have heavy skip. See para. 720(e,g). →		
Splits	← Equal to the width →						← Equal to 1-1/2 times the width →			← Equal to 1/6 length →		
Wane	← 1/4 thickness × 1/4 width × full length or equivalent; must not exceed 1/2 thickness × 1/3 width for up to 1/4 length. Also see para. 750. →						← 1/3 thickness × 1/3 width × full length or equivalent; must not exceed 2/3 thickness × 1/2 width for up to 1/4 length. Also see para. 750. →			← 1/2 thickness × 1/2 width × full length or equivalent; must not exceed 7/8 thickness or 3/4 width for up to 1/4 length. Also see para. 750. →		
Bow	← 10 ft/1-3/8 in.; 12 ft/1-1/2 in.; 14 ft/2 in.; 16 ft/2-1/2 in. →						← 10 ft/1-1/2 in.; 12 ft/2 in.; 14 ft/2-1/2 in.; 16 ft/3-1/4 in. →			← 10 ft/2-3/4 in.; 12 ft/3 in.; 14 ft/4 in.; 16 ft/5 in. →		
Crook	10 ft	12 ft	14 ft	16 ft	10 ft	12 ft	14 ft	16 ft	10 ft	12 ft	14 ft	16 ft
2×4	3/8 in.	1/2 in.	5/8 in.	3/4 in.	1/2 in.	11/16 in.	7/8 in.	1 in.	3/4 in.	1 in.	1-1/4 in.	1-1/2 in.
2×6	5/16 in.	7/16 in.	9/16 in.	11/16 in.	7/16 in.	5/8 in.	3/4 in.	7/8 in.	5/8 in.	7/8 in.	1-1/8 in.	1-3/8 in.
2×8	1/4 in.	13/32 in.	1/2 in.	9/16 in.	3/8 in.	1/2 in.	5/8 in.	3/4 in.	1/2 in.	13/16 in.	1 in.	1-1/8 in.
2×10	7/32 in.	3/8 in.	7/16 in.	1/2 in.	1/4 in.	7/16 in.	1/2 in.	5/8 in.	7/16 in.	3/4 in.	7/8 in.	1 in.
2×12	3/16 in.	9/32 in.	3/8 in.	7/16 in.	3/16 in.	3/8 in.	3/8 in.	1/2 in.	3/8 in.	9/16 in.	3/4 in.	7/8 in.

Dense grain: Requires 6 rings/in. and 1/3 summerwood or 4 rings/in. and 1/2 summerwood.

Exceptionally light weight pieces: Should not be placed in No. 2 and higher grades (exceptionally light weight pieces have less than 15% summerwood).

**Table 6.4—Grading Rule Specifications for Southern Pine Timber (Standard Grading Rules for Southern Pine Lumber 2002; used courtesy of Southern Pine Inspection Bureau)**

Grading rules for timbers								
Characteristics	Select Structural			No. 1			No. 2	
Compression wood	Not allowed in damaging form for the grade considered							
Slope of grain	1 in 14			1 in 11			1 in 6	
Decay	In knots only			In knots only			Heart-center decay or unsound red heart and equiv. streaks limited to 10% cross section if wholly enclosed within four surfaces of each piece and 5% otherwise	
Holes	Medium – well scattered			Medium – well scattered			Limited to 1-1/2 in. in diameter	
Knots (nominal width of face) (in.)	Narrow face and at edge of wide face (in.) (2)	Centerline wide face (in.)	Unsound knots (in.) (1)	Narrow face and at edge of wide face (in.) (2)	Centerline wide face (in.)	Unsound knots (in.) (1)	Narrow face and at edge of wide face; centerline wide face (in.)	Unsound knots (in.) (1)
5	1-3/8		1	1-3/4		1-3/8	2-1/2	2
6	1-5/8	1-5/8	1-1/4	2-1/8	2-1/8	1-5/8	3	2-1/4
8	1-7/8	2-1/4	1-1/2	2-1/2	2-3/4	2	4-1/2	2-3/4
10	2-1/8	2-3/4	2	2-3/4	3-1/2	2-1/2	5-1/2	3
12	2-3/8	3-1/4	2-1/8	3-1/8	4-1/4	2-7/8	6-1/2	3-1/2
14	2-1/2	3-5/8	2-1/4	3-3/8	4-3/4	3-1/8	7-1/2	3-3/4
16	2-3/4	3-7/8	2-1/2	3-1/2	5	3-3/8	8	4
18	2-7/8	4-1/8	2-1/2	3-1/2	5-1/4	3-1/2	8-1/2	4
20	3	4-3/8	3	3-1/2	5-1/2	3-1/2	9	4
	Sound, firm, encased, and pith knots			Sound, firm, encased, and pith knots			Sound, firm, encased, and pith knots	
	(1) In unsound knots as allowed, decay must be confined to the knot itself and not be in surrounding wood and not penetrate deeper than 1-1/2 in. (2) In timbers of equal face, knots are permitted throughout as specified for narrow faces regardless of location.						(1) In unsound knots as allowed, decay must not penetrate deeper than 2 in.	
Shakes, checks, splits	Splits not longer than thickness of piece; shakes and surface checks not deeper than 1/3 thickness if not dry and 3/8 thickness if dry			Splits not longer than thickness of piece; shakes and surface checks not deeper than 1/3 thickness if not dry and 3/8 thickness if dry			Splits not longer than 1-1/4 times thickness of piece; shakes and surface checks not deeper than 1/2 thickness	
Skips	Hit and Miss in 10% of pieces			Hit or Miss dressing			Hit or Miss dressing except occasional scant width and thickness from full length skip limited to 1/8 in., must be No. 1 otherwise throughout any portion scant over 1/16 in.	
Stain	Medium if dry; not limited if ordered green			Medium if dry; not limited if ordered green			Medium if dry; not limited if ordered green	
Wane	1/8 the width of face and 1/4 length			1/6 the width of face and 1/3 length			1/4 face on one edge and 1/3 face on both edges	
Warp	Very light			Very light			Light	

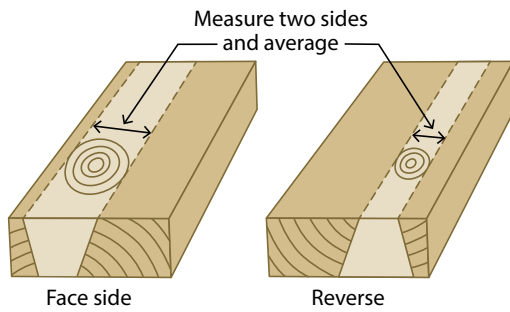
**Table 6.5—Grading Rules Specifications for NeLMA (WWPA) Timbers**

Beams and stringers								
Characteristics	Select Structural			No. 1			No. 2	
Slope of grain	1 in 14			1 in 10			1 in 6	
Decay	None			None			Small spots of unsound wood well scattered, 1/6 the face width	
Knots (nominal width of face) (in.)	Edge wide face (in.)	Centerline wide face (in.)	Unsound knots	Edge wide face (in.)	Centerline wide face (in.)	Unsound knots	Edge of wide face and centerline of wide face (in.)	Unsound knots
8	1-7/8	2		2-5/8	3		4-1/2	
10	2	2-5/8		2-7/8	3-3/4		5-5/8	
12	2-1/8	3-1/8		3-1/4	4-1/2		6-7/8	
14	2-3/8	3-3/8		3-1/2	5		7-1/2	
16	2-1/2	3-5/8		3-3/4	5-1/4		8-1/8	
18	2-3/4	3-5/8		3-7/8	5-5/8		8-5/8	
20	2-7/8	3-7/8		4-1/8	5-7/8		9-1/8	
22	3	4		4-3/8	6-1/4		9-1/2	
24	3-1/8	4-1/4		4-1/2	6-1/2		10	
	Sound, tight and well-spaced			Sound, tight and well-spaced			Sound, not firmly fixed or holes, well-spaced	
Shakes	1/6 the thickness on end			1/6 the thickness on end			1/2 length, 1/2 thickness. If through at ends, limited as splits.	
Splits	Splits equal in length to 1/2 the width of the piece or equivalent of end checks			Splits equal in length to width of the piece or equivalent of end checks			Medium or equivalent end checks	
Checks	Seasoning checks, single or opposite each other with a sum total equal to 1/4 the thickness of the piece			Seasoning checks, single or opposite each other with a sum total equal to 1/2 the thickness of the piece			Seasoning checks	
Skips	Occasional skips 1/16 in. deep, 2 ft in length			Occasional skips 1/8 in. deep, 2 ft in length			1/8 in. deep, 2 ft in length, or 1/16 in. skip full length	
Stain	Stained sapwood. Firm heart stain, 10% of width or equivalent.			Stained sapwood. Firm stained heartwood.			Stained wood	
Wane	1/8 of any face, or equivalent slightly more for a short distance			1/4 of any face or equivalent slightly more for a short distance			1/3 of any face, or equivalent slightly more for a short distance	

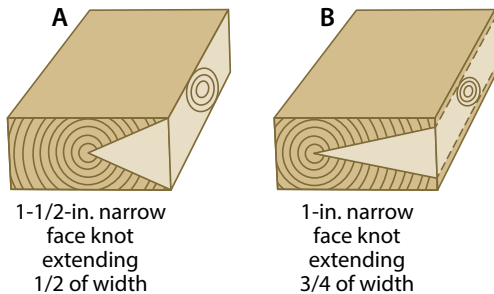
**Table 6.5—Grading Rules Specifications for NeLMA (WWPA) Timbers—con.**

Posts and timbers						
Characteristics	Select Structural		No. 1		No. 2	
Slope of grain	1 in 12		1 in 10		1 in 6	
Decay	None		None		Small spots of unsound wood well scattered, 1/6 the face width	
Knots (nominal width of face) (in.)	Anywhere on wide face (in.)	Unsound knots (in.)	Anywhere on wide face (in.)	Unsound knots (in.)	Anywhere on wide face (in.)	Unsound knots (in.)
5	1		1-1/2		2-1/2	1-1/4
6	1-1/4		1-7/8		3	1-1/2
8	1-5/8		2-1/2		3-3/4	1-7/8
10	2		3-1/8		5	2-1/2
12	2-3/8		3-3/4		6	3
14	2-1/2		4		6-1/2	3-1/4
16	2-3/4		4-1/4		7	3-1/2
18	3		4-1/2		7-1/2	3-3/4
	Sound, tight and well-spaced		Sound, tight and well-spaced		Sound, not firmly fixed or holes, well-spaced	
Shakes	1/3 the thickness on end		1/3 the thickness on end		1/2 length, 1/2 thickness. If through at ends, limited as splits.	
Splits	Splits equal in length to 3/4 the thickness of the piece or equivalent of end checks		Splits equal in length to width of the piece or equivalent of end checks		Medium or equivalent end checks	
Checks	Seasoning checks, single or opposite each other with a sum total equal to 1/2 the thickness of the piece		Seasoning checks, single or opposite each other with a sum total equal to 1/2 the thickness of the piece		Seasoning checks	
Skips	Occasional skips 1/16 in. deep, 2 ft in length		Occasional skips 1/8 in. deep, 2 ft in length		1/8 in. deep, 2 ft in length, or 1/16 in. skip full length	
Stain	Stained sapwood. Firm heart stain, 10% of width or equivalent.		Stained sapwood. Firm stained heartwood.		Stained wood	
Wane	1/8 of any face, or equivalent slightly more for a short distance		1/4 of any face, or equivalent slightly more for a short distance		1/3 of any face, or equivalent slightly more for a short distance	





Grade	Knot size on narrow face (in.)	Knot may extend into piece
No. 1	1-1/2	1/2 of width (A)
	1	3/4 of width (B)
No. 2	1-1/2	Slightly less than 3/4 of width
No. 3	1-1/2	Slightly less than width



**Figure 6.5—Diagram from a pocket guide showing measurement of knots on 2- to 4-in. lumber that included structural joists and planks (SPIB 2002). Used courtesy of Southern Pine Inspection Bureau.**

wide face have the least effect on strength grade; edge knots on the wide or narrow face have the most effect on strength and grade.

In general, knots have greater effect on strength in tension than compression; in bending, the effect depends on whether a knot is in the tension or compression side of a beam. Small knots along the centerline have little or no effect, but a very large knot along the centerline can have a significant influence on strength. Intergrown (or live) knots resist (or transmit) some kinds of stress, but encased knots (unless very tight) or knotholes resist (or transmit) little or no stress. On the other hand, distortion of grain is greater around an intergrown knot than around an encased (or dead) knot of equivalent size. As a result, overall strength effects are roughly equalized, and often no distinction is made in stress grading between intergrown knots, dead knots, and knotholes.

The presence of a knot has a greater effect on most strength properties than on stiffness. The zone of distorted grain (cross grain) around a knot has less “parallel to piece” stiff-

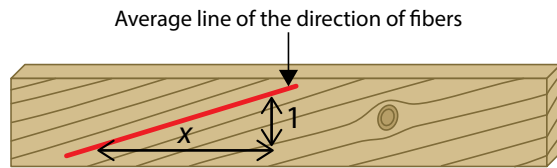


**Figure 6.6—Example of using grid to establish the size of knot in bridge member. The measured knot in the example is 1-1/2 in.**

ness than does straight-grained wood; thus, localized areas of low stiffness are often associated with knots. However, such zones generally constitute only a minor part of the total volume of a piece of lumber. Because overall stiffness of a piece reflects the character of all parts, stiffness is not greatly influenced by knots.

It is important to know the size and location of knots in wood members of a structure. The effect of knots on strength depends approximately on the proportion of the cross section of the piece of lumber occupied by the knot, knot location, and distribution of stress in the member. Grading criteria thus place limits on knot sizes in relation to the width of the face and location on the face in which the knot appears (Fig. 6.5), and the influence of the worst or most severe knot determines whether the knot is the limiting factor for determining the grade estimate. Compression members are stressed about equally throughout, and no limitation related to location of knots is imposed. In tension, knots along the edge of a member cause an eccentricity that induces bending stresses, and they should therefore be more restricted than knots away from the edge. In simply supported structural members subjected to bending, stresses are greater in the middle of the length and at the top and bottom edges than at mid-height. These facts are recognized in some grades by different limitations on the sizes of knots in different locations.

Knot sizes are likely to be difficult to assess on many members in structures. A scale is often used for quick estimates of knot size. Anthony et al. (2009) discuss another useful technique (a grid on a clear film) for estimating knots in dimension lumber. When properly aligned, the grid allows you to make a good estimate of knot size to the closest 1/4 in. (Fig. 6.6). Accurately capturing maximum knot size for the centerline and edge of the member is highly important; these are usually the controlling features for establishing grade.



**Figure 6.7—Definition of slope of grain is the ratio of rise to run (1:x).**



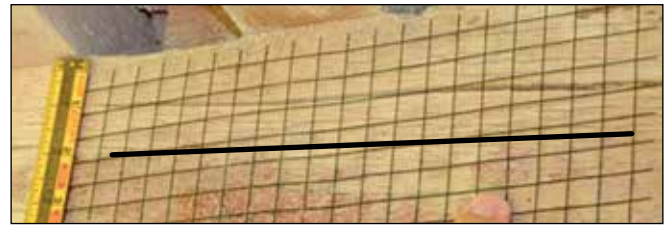
**Figure 6.8—Example of using checking in a member to measuring the slope of grain in bridge. The end of the scale points to the start of one check.**

### Slope of Grain

Slope of grain is a ratio expressing the amount the grain slopes up or down within a set distance along the long axis of the member (Fig. 6.7). A nonzero slope of grain (cross grain) reduces mechanical properties of lumber. Severely cross-grained pieces are also undesirable because they tend to warp with changes in moisture content. Stresses caused by shrinkage during drying are greater in structural lumber than in small, clear, straight-grained specimens and are increased in zones of sloping or distorted grain. To provide a margin of safety, the reduction in design properties resulting from cross grain in visually graded structural lumber is considerably greater than that observed in small, clear specimens that contain similar cross grain.

Drying checks in timber generally follow the slope of grain and can be used to determine the slope of grain on any visual surface, including painted members. Figure 6.8 shows an example of how checks indicate the slope of grain of a member. Other times the grain will be obvious on the unfinished surfaces of a member.

To measure slope of grain, the clear sheet with a printed 1/2-in. grid can once again be put to use (Fig. 6.9). In this example, the area that appears to have significant slope of grain should be measured from an axis parallel to the long axis



**Figure 6.9—Use of grid to easily estimate the slope of grain. The 2:18 grids above implies 1 in 9 slope of grain. The black line shows the direction of slope of grain.**

of the member. The grid can be used to establish the rise-over-run ratio. To do so, the total number of inches for the rise can be determined along the vertical axis by counting from the lowest point of the rise to the highest point of the rise (or wherever the grain crosses the edge of the acetate sheet). The total number of inches in the run can be determined along the horizontal axis by counting across from the lowest point of the rise to the highest point of the rise (or wherever the grain crosses the edge of the acetate sheet). These measurements can then be used to represent the actual slope of grain over a given length to determine the appropriate grade. As with knots, the most severe slope of grain in a member should be identified and, depending on its severity, may be the limiting factor for grade.

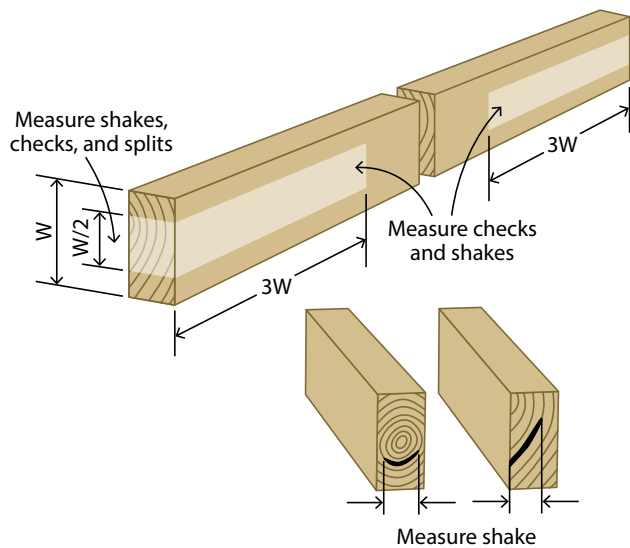
### Decay

Decay in most forms should be prohibited or severely restricted in stress grades because the extent of decay is difficult to determine and its effect on strength is often greater than visual observation would indicate (Gonzalez and Morrell 2012). Decay of the pocket type (for example, *Fomes pini*) can be permitted to some extent in stress grades, as can decay that occurs in knots but does not extend into the surrounding wood. If evidence of extensive decay is present, for example, if most of the section is deteriorated, replacing the member is the best option.

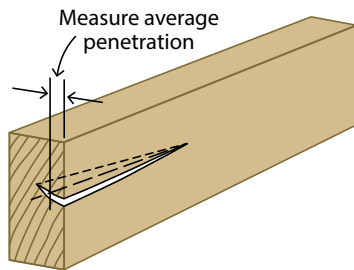
In a field inspection, decay can be detected by a close examination of texture and color of the wood. Decay can be indicated by color and/or texture changes such as brown, cubical, friable wood, or by soft, white, brittle wood. Decay would also clearly be suggested by the presence of mushrooms or other fruiting bodies. Also, the absence of wood can be suggestive of decay. Decay is often more severe where moisture collects or is trapped, such as where two pieces of wood overlap, or where fasteners penetrate the wood. A probe can be used to determine if wood structure is weakened (Chapter 2).

### Checks, Splits, and Shake

Checks and splits have little influence on Post and Timber members but can affect the behavior of Beam and Stringer members. Shake in a Beam and Stringer is measured between lines enclosing the shake and parallel to the wide face.



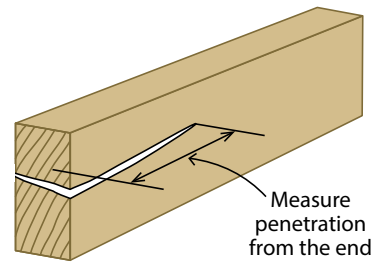
**Figure 6.10—Beams and stringer checks, shake, and split measurement.**



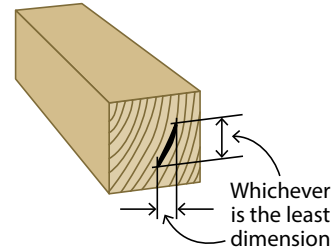
**Figure 6.11—Checks in post and timber.**

Checks are separations on the surface of the wood that normally occur as a result of drying wood. Splits are a separation of the wood through the piece to the opposite surface or to an adjoining face. Checks and splits are rated by only the area of actual opening. An end-split is considered equal to an end-check that extends through the full thickness of the piece. The effects of checks and splits on strength and the principles of their limitation are the same as those for shake (below).

Shake (or “ring-shake”) is the separation of annual rings caused by weak or absent bonds between them and is presumed to extend lengthwise within a member without limit. Because shake reduces resistance to shear in members subjected to bending, grading rules therefore restrict shake most closely in those parts of a bending member (Beam and Stringer) where shear stresses are highest. In members with limited cross-grain, which are subjected only to tension or compression (Post and Timber), shake does not affect strength greatly. Shake may also be limited in a grade because of appearance and because it permits entrance of moisture, which can result in decay.



**Figure 6.12—Split measurement.**



**Figure 6.13—Shake in post and timber.**

How checks, splits, and shake are measured depends on the intended use of the member. For all grades of members intended to be used as Beam and Stringer, checks, splits, and shake are measured in the middle half of the width. Restrictions on checks apply for a distance from the ends equal to three times the width of the wide face. Shake is measured from the end grain of the member between lines enclosing the shake and parallel to the wide face (Fig. 6.10). Checks are measured as an average of the penetration perpendicular to the wide face (Fig. 6.11). Where two or more checks appear on the same face, only the deepest one is measured. Where two checks are directly opposite each other, the sum of their deepest penetration is considered.

Splits are measured as the penetration of a split from the end of the piece and parallel to the edges of the piece (Fig. 6.12).

In Post and Timber, shake is measured at the ends of pieces, between lines parallel with the two faces that give the least dimension (Fig. 6.13). If the member is below 16% moisture content, the size of the shake may be 1.5 times the size permitted in the grade.

### Density, Rate of Growth, and Percentage of Late-Wood

The strength and stiffness of clear wood are related to its density, with denser wood generally being stronger and stiffer than less dense wood. In some species, based on the structure of the wood, rate of growth (rings per inch) and percentage of latewood can give an indication of the density of the wood. Strength is related to mass per unit volume

(density) of clear wood. Properties assigned to lumber are sometimes modified by using rate of growth and percentage of latewood as measures of density. Typically, selection for density requires that rings per unit length and percentage of latewood be within a specified range. Some very low strength pieces can be eliminated from a grade by excluding those that are exceptionally low in density.

### Heartwood and Sapwood

Heartwood or sapwood is often not taken into account in structural grading because heartwood and sapwood are assumed erroneously to have essentially equal mechanical properties. However, heartwood is sometimes specified in a visual grade because heartwood of some species is more resistant to decay than is sapwood. If heartwood of a particular species is decay resistant, heartwood may be specified for replacement members if the wood is to be untreated and will be exposed to a decay hazard. On the other hand, sapwood takes preservative treatment more readily than does heartwood and is preferable for lumber that will be treated with preservatives.

### Pitch Pockets

Pitch pockets ordinarily have so little effect on structural lumber that they can be disregarded in stress grading if they are small and limited in number. The presence of a large number of pitch pockets, however, may indicate shake or weakness of bond between annual rings, and extremely large pitch pockets may function as areas of ring shake and thus can be treated as such for grading purposes.

### Wane

Wane refers to bark or lack of wood on the edge or corner of a piece of lumber. Requirements of appearance, fabrication, or ample bearing or nailing surfaces generally impose stricter limitations on wane than does strength. Wane is therefore limited in structural lumber on those bases rather than for its influence on timber strength.

## What to Prioritize in Field Estimation Grading

When inspecting a structure, not all properties discussed above will be easily measured. Fortunately, the most significant strength-reducing factors in structural members of wooden structures (size and location of the largest knots, slope of grain, and presence of decay) are some of the most easily field-assessable characteristics. The most time and greatest care should be taken to measure these properties on the critical members. Next in importance would be determining rings per inch, if possible, to give an indication of relative density of the member. If these properties are available, an approximation of grade can be established and thereby a reasonable first estimate of design values for the member should be attainable.

## Condition Assessment

The principal reason for most inspections of a wooden structure is to determine the condition of the wood components so that a judgment can be made on the capacity of the structure. Helpful tips and methods for conducting condition assessments of wood structures have been described in detail in Chapters 1 to 5. These chapters emphasize where problems are most likely to occur in wooden structures. Missing or failed components, wood in ground contact, wood with moisture stains, wood with the presence of fungal fruiting bodies, decayed wood at material interfaces, wood with insect bore holes and mud tubes, sill beams and plates in contact with masonry, burned or charred wood, and corroded or damaged fasteners or connections are all areas that are referred to as needing close inspection. If extensive decay or evidence of large-scale insect attack are present, the member is most likely compromised and should be replaced. Decay and insect attack can result in severe reduction in strength of the members (Gonzalez and Morrell 2012). Also, structurally damaged members (members that have already failed) need to be replaced. Choices of members to inspect depend on the goal of the inspection. Regardless the condition of the member needs to be considered when establishing an estimate of grade.

## Examples of Grade Estimation

Nine example members from different structures are tabulated in Table 6.6 to illustrate estimation of grade for a member. Entries 1 to 6 look at dimension lumber members; entries 7 to 9 look at the grade of timber size members.

### Dimension Lumber Grading Examples

Six dimension lumber member grade estimation examples are presented in Table 6.6. Member 1 was identified as a piece of red oak and had a measured dimension of a full 3 by 8 in., making it a structural joist and plank. No grade stamp was present. There was, however, considerable decay present in this member. Even though the knot sizes and slope of grain for a 3 by 8 member, based on the criteria in Table 6.3, would have allowed for an estimated grade of No. 1, the presence of severe decay made this member a candidate for replacement.

Member 2 was identified as Douglas-fir, with measured dimensions of 1.5 by 5.5 in. It was in good shape with a clearly marked No. 1 grade stamp. Because there was no indication of decay or damage, the stamped grade will be used.

Initial inspection of member 3 indicated that the member was northern red oak and in good shape with no damage or decay present. Member 3 was a full 2 by 6 in. and can be considered a structural joist and plank. No grade stamp was present. There was good access to all sides of the member for over 70% of its length. Measured slope of grain and knot dimensions were compared with allowable knot sizes and

**Table 6.6—Examples for estimation of member grade (members are not all from same bridge)**

Member and species	Member size (in.)	Use	Percent access to the member and sides	Damage or decay present	Grade Stamp	Largest unsound knot (in.)	Largest edge knot on wide face (in.)	Largest center-line knot on wide face (in.)	Largest narrow face knot (in.)	Slope of grain (1:x)	Final estimated grade/recommendations
1 Red Oak	3 by 8	Str. J&P	60% 3 of 4	Yes	No	N/A	N/A	N/A	N/A	N/A	
			Grade estimate								Replace
2 Douglas-fir	1.5 by 5.5	Str. J&P	70% all	No	Yes	N/A	N/A	N/A	N/A	N/A	
			Grade estimate								No. 1
3 Northern Red Oak	2 by 6	Str. J&P	70% all	No	No	1.5	1.75	2.75	1.5	1:12	
			Grade estimate								No. 2
4 Cottonwood	2 by 7.5	Str. J&P	50% 3 of 4	No	No	1.25	2.0	2.75	2.0	1:9	
			Grade estimate								Sel. Str.
5 Southern Pine	2 by 4	Str. LF	100% all	No	No	0.75	1.25	1.25	0.5	1:18	
			Grade estimate								No. 2
6 American Chestnut	2 by 6	Str. J&P	80% all	No	No	1.5	2.0	2.5	2.75	1:8	
			Grade estimate								No. 2
7 Southern Pine	5.5 by 7.5	P-T	50% all 3 of 4 rest	No	No	1.5	2.25	2.75	2.0	1:12	
			Grade estimate								Sel. Str.
8 Douglas-fir	7.5 by 9.5	P-T	100% all	No	No	1	1	1.25	1	1:18	
			Grade estimate								Sel. Str.
9 White Ash	5 by 8	B-S	70% 3 of 4	No	No	1.5	3.0	3.5	2.75	1:6	
			Grade estimate								No. 2

Str. J&amp;P: Structural Joist and Plank (2–4 in. thick, 5 in. and wider).

Str. LF: Structural Light Framing (2–4 in. thick, 2–4 in. wide).

P-T: Post or Timber (5 by 5 in. and larger, width not more than 2 in. greater than thickness).

B-S: Beam or Stringer (5 in. and thicker, width more than 2 in. greater than thickness).

slope of grain for a 2 by 6 shown in Table 6.3. Member 3 grades out as a Select Structural grade member according to its slope of grain, but the knot characteristics are that of a No. 2 member. The grade level that a member qualifies for always takes the lowest estimated grade characteristic for the member. Therefore, the grade for member 3 is estimated to be No. 2.

Initial inspection of member 4 identified the species as cottonwood and again indicated that the member was in good shape with no damage or decay present. Member 4 had measured dimensions that were closest to the dimensions of a piece of nominal 2 by 8 dimension lumber and could be considered a structural joist and plank. There was very good access to three of the four sides for 50% of this member, with limited access to the wide face for the remaining portions of the member. Lack of access to the faces of the member makes the estimate of grade of this member more uncertain. Using the criteria detailed in Table 6.3, the tabulated knot information available suggests the grade is No. 1, whereas the slope of grain value only qualifies for No. 2. Therefore estimated grade for member 4 is No. 2.

Initial inspection identified member 5 as Southern Pine with no decay present. Member 5 had a measured dimension of a full 2 by 4 in. and can be classified as a structural light framing member. No grade stamp was present. There was very good access to all sides of the member. The knot dimensions and slope of grain were compared against the criteria found in Table 6.3. One large edge knot on the wide face forced a reduction in the estimated grade for member 5 to No. 2.

Initial inspection identified member 6 as American chestnut. Member 6 had a measured cross-sectional dimension of 2 by 6 in. There was good access to all sides of the member for 80% of its length. A probe test revealed no severe decay, and no other damage was observed. Applying the criteria in the national grading rule in Table 6.3 for dimension lumber, the recorded knot sizes and slope of grain suggest an approximate grade of No. 2 for member 6.

### Timber Grading Example

Three timber grading examples are presented in Table 6.6. Initial inspection identified member 7 as Southern Pine. Member 7 had measured dimensions of 5.5 by 7.5 in. The dimension of this member allows it to be treated as a nominal 6 by 8 Post and Timber. Because the member is Southern Pine and Southern Pine grading rules do not distinguish between Beam and Stringer or Post and Timber, only one criterion for knots and slope of grain is given in Table 6.4. Initial inspection of the member indicated that the member was in good shape with no damage present or obvious signs of decay. There was good access to all sides of the member for over 50% of its length and access to three sides for the remaining length of the member. The estimated slope of grain information for member 7 is No. 1.

Initial inspection identified member 8 as Douglas-fir and indicated that the member was in good shape with no damage present or obvious signs of decay. Member 8 had a measured dimension of 7.5 by 9.5 in. This member was being used as a support column and had all sides visible. The dimension and use of this timber make it a Post or Timber. The Post and Timber rules presented in Table 6.5 can be applied to Douglas-fir timbers. There were very few and quite small knots present in this member. Member 8 easily met the criteria for Select Structural.

Initial inspection identified member 9 as ash and indicated that the member was in good shape with no damage present or obvious signs of decay. Member 9 had a measured dimension of 5 by 8 in. The dimension and use of this member makes it a Beam and Stringer. The grading rules for timber Beam and Stringer are given in Table 6.5. There was good access to only three sides of the member for over 70% of its length. The member knot sizes indicated the beam could be graded out as a No. 1 but a severe slope of grain downgraded member 9 to No. 2.

### Words of Advice for Size and Grade Estimation

This manual is meant to provide the reader with very basic information about how grading is conducted and a very basic method for estimating grade for members. The most accurate estimate of the in-place grade of a member would be obtained by certified graders that have extensive experience and knowledge of various structural lumber grades. The field inspector, however, should be able to get a good idea of the species of the wood and the size and quality of the members that are in the structure.

Keep good records indicating the amount of each member that was accessible and your confidence of the estimated grade. Many times it will be impossible to see a large portion of a member, and you truly will need to make an educated guess that, based on what you can see, the same knots and slope of grain conditions may extend to the rest of the member. To arrive at an estimate of the design value for the member, the condition and your confidence in the estimate of grade is important.

### Estimating Design Values

Wanting to assign structural lumber values to lumber found in historic structures is certainly nothing new. A 1954 article by Lyman Wood in *Southern Lumberman* explored issues associated with assigning structural design values to old lumber (Wood 1954). Loferski and others used nondestructive evaluation and testing techniques to determine mechanical properties (Loferski et al. 1996). Falk and others looked at assigning design values to material from wood salvaged from building deconstruction projects (Falk et al. 2008, Lantz and Falk 1997). Even for newly produced lumber, a certain amount of uncertainty will always be associated with

design value estimation. Assigning design values to in situ lumber and timber is more difficult because it requires judgment about the condition of members that you cannot fully access. It also requires you to judge how the prior load and environmental history has affected the member. An inspector must always be aware that judgments can only be made on what you can see and something detrimental could be lurking in the unexposed portions of the member.

### Words of Caution about Estimating Design Values

Many times an inspector will not be able to see all sides of a member when trying to estimate its grade and condition. Even for very experienced certified graders, all that can truly be said about members that are observed in place is that no defects were found for the sections observed that exclude a member from a grade. There is no guarantee that this grade estimate applies to the unreachable portions of the member. The size of defects on exposed surfaces will provide some clue as to unexposed surfaces. Some confidence in a grade assignment may be gained from the grade assessment of other more accessible members. Great care, however, should be taken when determining the design values for members in place. Reducing the design value of the member by an additional uncertainty factor ( $U_n$ )—perhaps as great as 2—is a reasonable thing to do.

### Steps in Making a First Estimate of Design Values for Members

Once you have identified the species of wood involved, determined the dimension, established the condition, and estimated a grade, follow the steps (Fig. 6.14) to establish an estimate of design values for the members you have chosen. The path to assigning design values may seem confusing at first glance. Examples of each are provided to help guide the reader through the design value estimation process. Only Select Structural, No. 1, No. 2, and No. 3 grades are considered for assigning design values.

After the species, size, condition, and grade of a member is established, the next step in estimating a design value is to determine whether the species can be found in the list of species that have design values in the NDS supplement (AWC 2012). If a wood member has remained dry and does not have excessive decay, damage, splitting, or checking, one can assume that the member has equivalent properties of material produced today. A list of current species in the NDS supplement is given in Table 6.7.

Species listed in the NDS Supplement include the most common species that are present in wooden structures. Procedures for estimating design values for species that are found in the NDS Supplement are given in the following section. Note that some species listed in Table 6.7 are found as groups or individually. For example, a mixed oak group and northern red oak are both listed. If you are confident

of your wood identification, use values for the individual species; otherwise it is best to use the more conservative estimate for the species group. If the species you have is not in the list of species given in Table 6.7, then you should proceed directly to the section on “Assigning estimated design values for species not found in the NDS Supplement.” Your estimate of design values will depend on whether small clear wood property data for your species exist. Alternatively, you might use the low “sweeper group” design values (such as Northern Species or Western woods) and the methods of the following section for an initial estimate of design values.

Member grading examples in Table 6.6 are also used to illustrate design value assignment. Members 1, 2, 3, 4, 6, and 7 in Table 6.6 are all species listed in the NDS supplement. No design value need be calculated for member 1 in Table 6.6 because it was identified through close inspection to have severe decay and needs to be replaced. The other five members are assigned estimated design values in the following section. Members 5 and 8 in Table 6.6 are not in the NDS Supplement and are assigned estimated design values in the section on “Assigning estimated design values for species not found in the NDS Supplement.” All estimated design values reported below apply the rounding rules specified in ASTM D 245 (Table 6.8).

### Assigning Estimated Design Values for Species Found in the NDS Supplement

If the species of the member you are interested in is in the NDS Supplement, your assignment of design values is rather straightforward. Once a grade estimate has been established, determining the design values for a member is a matter of reading the design values for that particular species from a table in the NDS supplement and applying the appropriate moisture, size, and uncertainty reduction factors.

Depending on size and grade of the member, design values for dimension lumber and timber can be found in one of three tables (4A, 4B, or 4D) in the NDS supplement. The members in Table 6.6 provide examples that use each type of table.

Visually graded structural wood products are divided into two broad use categories—dimension lumber and timbers. If the smallest dimension of the member is less than 4.5 in. thick, the material can be considered dimension lumber. If the member is 5 in. or larger in smallest dimension, it is considered a timber.

Dimension lumber properties are tabulated in two different tables depending on species. If the member is not Southern Pine, you would look up the design values in table 4A; otherwise, if the member is Southern Pine you would look up the properties in table 4B of the NDS Supplement.

For timbers, design values for all species can be found in table 4D of the NDS Supplement. Timbers, with the

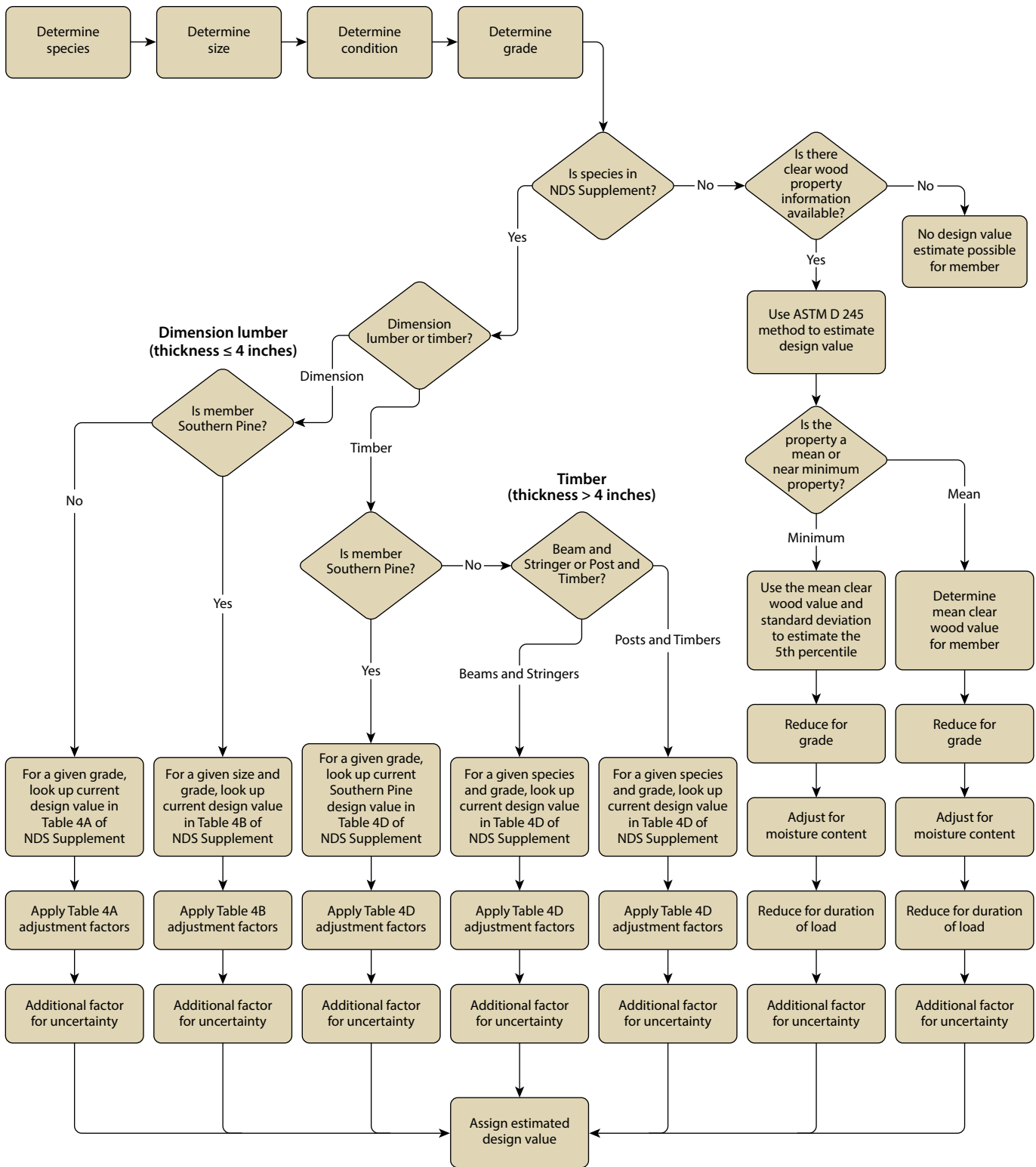


Figure 6.14—Flow chart for design value assignment.



**Table 6.7—Species with design values in the NDS Supplement (AWC 2012)**

NDS species or species combination	Species included in combination	Table with design value
Alaska Cedar		4A
Alaska Hemlock		4A
Alaska Spruce	Alaska Sitka Spruce Alaska White Spruce	4A
Alaska Yellow Cedar		4A
Aspen	Big Tooth Aspen Quaking Aspen	4A
Baldcypress		4A, 4D
Balsam Fir		4D
Beech-Birch-Hickory	American Beech Bitternut Hickory Mockernut Hickory Nutmeg Hickory Pecan Hickory Pignut Hickory Shagbark Hickory Shellbark Hickory Sweet Birch Water Hickory Yellow Birch	4A, 4D
Coast Sitka Spruce		4A, 4D, 4E
Douglas Fir-Larch	Douglas-fir Western Larch	4A, 4C, 4D, 4E
Douglas Fir-Larch (North)	Douglas-fir Western Larch	4A, 4C, 4D, 4E
Douglas Fir-South		4A, 4C, 4D, 4E
Eastern Hemlock		4D
Eastern Hemlock-Balsam Fir	Balsam Fir Eastern Hemlock Tamarack	4A
Eastern Hemlock-Tamarack	Eastern Hemlock Tamarack	4A, 4D, 4E
Eastern Hemlock-Tamarack (North)	Eastern Hemlock Tamarack	4D, 4E
Eastern Softwoods	Balsam Fir Black Spruce Eastern Hemlock Eastern White Pine Jack Pine Norway (Red) Pine Pitch Pine Red Spruce Tamarack White Spruce	4A

**Table 6.7—Species with design values in the NDS Supplement (AWC 2012)—con.**

NDS species or species combination	Species included in combination	Table with design value
Eastern Spruce	Black Spruce	4D, 4E
	Red Spruce	
	White Spruce	
Eastern White Pine		4A, 4D, 4E
Eastern White Pine (North)		4E
Hem-Fir	California Red Fir	4A, 4C, 4D, 4E
	Grand Fir	
	Noble Fir	
	Pacific Silver Fir	
	Western Hemlock	
	White Fir	
Hem-Fir (North)	Amabilis Fir	4A, 4C, 4D, 4E
	Western Hemlock	
Mixed Maple	Black Maple	4A, 4D
	Red Maple	
	Silver Maple	
	Sugar Maple	
Mixed Oak	All Oak species under NeLMA rules	4A, 4D
Mixed Southern Pine	Any species in the Southern Pine species combination, plus either or both of the following: Pond Pine, Virginia Pine	4B, 4C, 4D
Mountain Hemlock		4D
Northern Pine	Jack Pine	4D, 4E
	Norway (Red) Pine	
	Pitch Pine	
Northern Red Oak	Black Oak	4A, 4D
	Northern Red Oak	
	Pin Oak	
	Scarlet Oak	
Northern Species	Any species graded under NLGA rules except Red Alder, White Birch, and Norway Spruce	4A, 4D, 4E
Northern White Cedar		4A, 4D, 4E
Ponderosa Pine		4D, 4E
Red Maple		4A, 4D
Red Oak	Black Oak	4A, 4D
	Cherrybark Oak	
	Laurel Oak	
	Northern Red Oak	
	Pin Oak	
	Scarlet Oak	
	Southern Red Oak	
	Water Oak	
	Willow Oak	
Red Pine		4D, 4E
Redwood		4A, 4D, 4E
Sitka Spruce		4D, 4E

**Table 6.7—Species with design values in the NDS Supplement (AWC 2012)—con.**

NDS species or species combination	Species included in combination	Table with design value
Southern Pine	Loblolly Pine	4A, 4C, 4D, 4E
	Longleaf Pine	
	Shortleaf Pine	
	Slash Pine	
Spruce-Pine-Fir	Alpine Fir	4A, 4C, 4D, 4E
	Balsam Fir	
	Black Spruce	
	Engelmann Spruce	
	Jack Pine	
	Lodgepole Pine	
	Red Spruce	
	White Spruce	
Spruce-Pine-Fir (South)	Balsam Fir	4A, 4C, 4D, 4E
	Black Spruce	
	Engelmann Spruce	
	Jack Pine	
	Lodgepole Pine	
	Norway (Red) Pine	
	Red Spruce	
	Sitka Spruce	
	White Spruce	
	Western Cedars	
Incense Cedar		
Port Orford Cedar		
Western Red Cedar		
Western Cedars (North)	Pacific Coast Yellow Cedar	4A, 4C, 4D, 4E
	Western Red Cedar	
Western Hemlock		4A, 4C, 4D, 4E
Western Hemlock (North)		4A, 4C, 4D, 4E
Western White Pine		4A, 4C, 4D, 4E
Western Woods	Any species in the Douglas Fir-Larch, Douglas Fir-South, Hem-Fir, and Spruce-Pine-Fir (South) species combinations, plus any or all of the following: Alpine Fir, Idaho White Pine, Mountain Hemlock, Ponderosa Pine, Sugar Pine	4A, 4C, 4D, 4E
White Oak	Bur Oak	
	Chestnut Oak	
	Live Oak	
	Overcup Oak	
	Post Oak	
	Swamp Chestnut Oak	
	Swamp White Oak	
White Oak		
Yellow Cedar		4A
Yellow Poplar		4A

Table 4A: Reference Design Values for Visually Graded Dimension Lumber (2–4 in. thick).

Table 4B: Reference Design Values for Visually Graded Southern Pine Dimension Lumber (2–4 in. thick).

Table 4C: Reference Design Values for Mechanically Graded Dimension Lumber.

Table 4D: Reference Design Values for Visually Graded timbers (5 by 5 in. and larger).

Table 4E: Reference Design Values for Visually Graded Decking.

**Table 6.8—Rounding Rules (ASTM D 245-11)**

Bending, tension parallel, and compression parallel to grain	For design value stresses 1,000 lb/in <sup>2</sup> (6.9 MPa) or greater, round to nearest 50 lb/in <sup>2</sup> (340 kPa)  For design value stresses less than 1,000 lb/in <sup>2</sup> (6.9 MPa), round to nearest 25 lb/in <sup>2</sup> (170 kPa)
Horizontal shear and compression perpendicular to grain	Round to nearest 5 lb/in <sup>2</sup> (34 kPa)
Modulus of elasticity	Round to nearest 100,000 lb/in <sup>2</sup> (69 GPa)

**Table 6.9—Size factors,  $C_f$  (AWC 2012)**

Grades	Width (in.)	$F_b$ Thickness		$F_t$	$F_{c//}$
		2 and 3 in.	4 in.		
Select Structural, No. 1, No. 2, and No. 3	2 and 3	1.5	1.5	1.5	1.15
	5	1.4	1.4	1.4	1.1
	6	1.3	1.3	1.3	1.1
	8	1.2	1.3	1.2	1.05
	10	1.1	1.2	1.1	1.0
	12	1.0	1.1	1.0	1.0
	14	0.9	1.0	0.9	0.9

exception of Southern Pine timber, are further subdivided into use categories with different values for timbers that can be described as a Beam or Stringer or as Post and Timber. Southern Pine members have no distinction in design values based on use category.

#### Dimension Lumber Species Found in NDS Supplement

Two subcategories of dimension lumber are (1) species that are not Southern Pine and (2) species that are Southern Pine. Design value estimates for each category are determined differently.

**Non-Southern Pine Dimension Lumber Species**—For members that are dimension lumber size and are not Southern Pine, design values found in table 4A in the NDS Supplement apply (AWC 2012). The values in table 4A are primarily for nominal 2- by 12-in. dimension lumber. These tabulated values must be corrected to the desired size using the size factors shown in Table 6.9. Members 2, 3, and 4 in Table 6.6 fall into this category of dimension lumber. The step-by-step estimation of design values for members 2, 3, and 4 are given in Tables 6.10, 6.11, and 6.12 respectively.

Table 6.10 shows steps for calculating estimated design values for member 2. Member 2 in Table 6.6 was identified as a piece of 2 by 6 Douglas-fir dimension lumber with a grade

stamp that identified the grade of the member as No. 1. It is an example of a member that fits into the dimension lumber size category (1.5 to 4 in. thick) and is not Southern Pine. The member was in good condition, and current design values for 2 by 12 No. 1 in table 4A of the NDS supplement apply. The appropriate size adjustments given in Table 6.9 are needed to convert these values to 2 by 6. Finally, because only 70% of the member was easily accessible, an additional uncertainty factor is applied as a precaution, giving the estimated design values listed in the far right column of Table 6.10. The estimated  $F_b$  value, for example, is 900 lb/in<sup>2</sup>.

Table 6.11 shows estimated design values for member 3 in Table 6.6, which was identified as a northern red oak 2- by 6-in. member with an approximate grade of No. 2. This is another example of a member that fits into the dimension lumber size category (1.5- to 4-in. thick) and is not Southern Pine. There was good access to 70% of the member. The baseline design values for northern red oak can be determined from table 4A of the NDS Supplement. Once again the appropriate size factors  $C_f$  shown in Table 6.9 must be applied to convert the member to a 2 by 6 size. Finally, a similar uncertainty factor of 0.7 is applied because not all the member was visible when graded. The resulting estimated design values for member 3 are given in the far right column of Table 6.11.

**Table 6.10—Example of design value estimation for No. 1 Douglas-fir 2 by 6**

Species	Estimated member size	Estimated member grade	Purpose	Property	Table 4A baseline design value <sup>b</sup>	$C_f$ Size adjustment factor	Un <sup>a</sup>	Estimated design value
Douglas-fir	1.5 by 5.5 in.	No. 1	Str. J&P	$F_b$ (lb/in <sup>2</sup> )	1,000	1.3	0.7	900
				$F_t$ (lb/in <sup>2</sup> )	675	1.3	0.7	600
				$F_v$ (lb/in <sup>2</sup> )	180	1.0	0.7	125
				$F_{cperp}$ (lb/in <sup>2</sup> )	625	1.0	0.7	440
				$F_{c//}$ (lb/in <sup>2</sup> )	1,500	1.1	0.7	1,150
				$E$ (10 <sup>6</sup> lb/in <sup>2</sup> )	1,700,000	1.0	0.7	1,200,000
				$E_{min}$ (10 <sup>6</sup> lb/in <sup>2</sup> )	620,000	1.0	0.7	400,000

<sup>a</sup>Un, uncertainty.<sup>b</sup>AWC (2012).**Table 6.11—Example of design value estimation for No. 2 Northern Red Oak 2 by 6**

Species	Estimated member size	Estimated member grade	Purpose	Property	Table 4A baseline design value <sup>b</sup>	$C_f$ Size adjustment factor	Un <sup>a</sup>	Estimated design value
Northern Red Oak	2 by 6	No. 2	Str. J&P	$F_b$ (lb/in <sup>2</sup> )	975	1.3	0.7	890
				$F_t$ (lb/in <sup>2</sup> )	575	1.3	0.7	525
				$F_v$ (lb/in <sup>2</sup> )	220	1.0	0.7	155
				$F_{cperp}$ (lb/in <sup>2</sup> )	885	1.0	0.7	620
				$F_{c//}$ (lb/in <sup>2</sup> )	725	1.1	0.7	560
				$E$ (10 <sup>6</sup> lb/in <sup>2</sup> )	1,300,000	1.0	0.7	910,000
				$E_{min}$ (10 <sup>6</sup> lb/in <sup>2</sup> )	470,000	1.0	0.7	329,000

<sup>a</sup>Un, uncertainty.<sup>b</sup>AWC (2012).

**Table 6.12—Example of design value estimation for No. 2 Cottonwood 2 by 8**

Species	Estimated member size	Estimated member grade	Purpose	Property	Table 4A baseline design value <sup>b</sup>	$C_f$ Size adjustment factor	Un <sup>a</sup>	Estimated design value
Cottonwood	2 by 8	No. 2	Str. J&P	$F_b$ (lb/in <sup>2</sup> )	625	1.2	0.5	375
				$F_t$ (lb/in <sup>2</sup> )	350	1.2	0.5	210
				$F_v$ (lb/in <sup>2</sup> )	125	1	0.5	65
				$F_{cperp}$ (lb/in <sup>2</sup> )	320	1	0.5	160
				$F_{c//}$ (lb/in <sup>2</sup> )	475	1.05	0.5	250
				$E$ (10 <sup>6</sup> lb/in <sup>2</sup> )	1,100,000	1	0.5	550,000
				$E_{min}$ (10 <sup>6</sup> lb/in <sup>2</sup> )	400,000	1	0.5	200,000

<sup>a</sup>Un, uncertainty.<sup>b</sup>AWC (2012).

Table 6.12 shows estimated design values for member 4 in Table 6.6, which was identified as a 2- by 7.5-in. piece of cottonwood, which is closest to the current dimension of a nominal 2 by 8. The approximate grade for this member was determined to be No. 2. The baseline design values for cottonwood can be found in table 4A of the NDS supplement. The appropriate size factors  $C_f$  shown in Table 6.9 must be applied to convert the member to a 2 by 8 size. During inspection, notes indicated that there was not good access to this member; only 50% of the member was visible on three of the four sides. This lack of access introduces a great deal of uncertainty into the estimate of grade, so a considerable reduction ( $Un = 0.5$ ) in design value estimates is certainly advised. The resulting estimated design values are given in the far right column of Table 6.12.

**Southern Pine Dimension Lumber in the NDS Supplement**—Table 6.13 shows steps for determining an estimated design value for member 5. Member 5 in Table 6.6 was identified as a 2- by 4-in. Southern Pine member whose approximate grade was No. 2. The size-specific design values for Southern Pine dimension lumber are tabulated in table 4B of the NDS supplement. To estimate design values, the inspector needs to find the entry that corresponds to the grade and closest size of the member of interest. In this case, for example, the 2 by 4 No. 2  $F_b$  given in table 4B is 1,100 lb/in<sup>2</sup>. Because the values are size-specific, a size adjustment factor is not necessary. The inspection notes also indicated easy access to all sides, so an uncertainty reduction is not needed. Estimated design values listed in the far

right column for member 5 is, in this case, the value given for Southern Pine 2 by 4 No. 2 of table 4B of the NDS Supplement.

#### Timber Values Found in NDS Supplement

Timber design values are found in table 4D of the NDS Supplement. There are again differences between how you treat Southern Pine and other species, but this time the difference is not as exaggerated. A different set of size adjustments apply to timbers than did to dimension lumber. For timbers that are subjected to loads applied to the narrow face, tabulated design values for bending are adjusted by a size adjustment found in ASTM D 245. Other properties do not receive a size adjustment. If the member depth is greater than 12 in., a new  $F_n$  can be calculated using

$$F_n = \left(\frac{12}{d}\right)^{1/9} F_o$$

where  $d$  is member depth,  $F_o$  is original bending strength, and  $F_n$  is adjusted bending strength.

**Southern Pine Timbers**—Southern Pine timbers have no distinction between the use classes of Beams or Stringers and Post and Timbers. Therefore, you only need to find the Southern Pine timber values for the grade you are interested in and apply them to the member.

Table 6.14 shows estimated design values for member 7. Member 7 in Table 6.6 was identified as a 5.5- by 7.5-in. Southern Pine member whose observable knots and slope of

**Table 6.13—Example of design value estimation for No. 2 Southern Pine 2 by 4**

Species	Estimated member size	Estimated member grade	Purpose	Property	Table 4B baseline design value <sup>b</sup>	$C_f$ Size adjustment factor	Un <sup>a</sup>	Estimated design value
Southern Pine	2 by 4	No. 2	Str. LF	$F_b$ (lb/in <sup>2</sup> )	1,100	1	1.0	1,100
				$F_t$ (lb/in <sup>2</sup> )	675	1	1.0	675
				$F_v$ (lb/in <sup>2</sup> )	175	1	1.0	175
				$F_{cperp}$ (lb/in <sup>2</sup> )	565	1	1.0	565
				$F_{c//}$ (lb/in <sup>2</sup> )	1,450	1	1.0	1,450
				$E$ (10 <sup>6</sup> lb/in <sup>2</sup> )	1,400,000	1	1.0	1,400,000
				$E_{min}$ (10 <sup>6</sup> lb/in <sup>2</sup> )	510,000	1	1.0	510,000

<sup>a</sup>Un, uncertainty.<sup>b</sup>AWC (2012).**Table 6.14—Example of design value estimation for No. 1 Southern Pine 6 by 8**

Species	Estimated member size	Estimated member grade	Purpose	Property	Table 4D baseline design value <sup>b</sup>	$C_f$ Size adjustment factor	Un <sup>a</sup>	Estimated design value
Southern Pine	6 by 8	No. 1	P-T	$F_b$ (lb/in <sup>2</sup> )	1,350	1	0.5	675
				$F_t$ (lb/in <sup>2</sup> )	900	1	0.5	450
				$F_v$ (lb/in <sup>2</sup> )	165	1	0.5	85
				$F_{cperp}$ (lb/in <sup>2</sup> )	375	1	0.5	190
				$F_{c//}$ (lb/in <sup>2</sup> )	825	1	0.5	415
				$E$ (10 <sup>6</sup> lb/in <sup>2</sup> )	1,500,000	1	0.5	750,000
				$E_{min}$ (10 <sup>6</sup> lb/in <sup>2</sup> )	550,000	1	0.5	275,000

<sup>a</sup>Un, uncertainty.<sup>b</sup>AWC (2012).

**Table 6.15—Example of design value estimation for Select Structural Douglas-fir 8 by 10**

Species	Estimated member size	Estimated member grade	Purpose	Property	Table 4D baseline design value <sup>b</sup>	$C_f$ Size adjustment factor	Un <sup>a</sup>	Estimated design value
Douglas-fir	8 by 10	Sel. Str.	P-T	$F_b$ (lb/in <sup>2</sup> )	1,500	1	1.0	1,500
				$F_t$ (lb/in <sup>2</sup> )	1,000	1	1.0	1,000
				$F_v$ (lb/in <sup>2</sup> )	170	1	1.0	170
				$F_{c\text{perp}}$ (lb/in <sup>2</sup> )	625	1	1.0	625
				$F_{c//}$ (lb/in <sup>2</sup> )	1,150	1	1.0	1,150
				$E$ (10 <sup>6</sup> lb/in <sup>2</sup> )	1,600,000	1	1.0	1,600,000
				$E_{\text{min}}$ (10 <sup>6</sup> lb/in <sup>2</sup> )	580,000	1	1.0	580,000

<sup>a</sup>Un, uncertainty.

<sup>b</sup>AWC (2012).

grain classified the member as a No. 1 timber. Design values for Southern Pine for this size and grade can be obtained directly from table 4D of the NDS Supplement. Inspection notes indicate that there was not good access to this member; only 50% of the member was visible on three of four sides. This suggests the need for a considerable uncertainty factor of 0.5. Estimated design values for member 7 are given in the far right column of Table 6.14.

**Non-Southern Pine Timbers**—For non-Southern Pine members, the value in the NDS Supplement that is appropriate for the member is linked to its species, dimensions, estimated grade, and use. If the member is 5 in. thick and its width is more than 2 in. greater than thickness, the member is a Beam or Stringer. If the member is 5 by 5 in. and larger with a width not more than 2 in. greater than thickness, the member is a Post and Timber.

Table 6.15 shows estimated design values for member 8. Member 8 in Table 6.6 was identified as a 7.5- by 9.5-in. Douglas-fir member that had observable knots and slope of grain that would approximate a Select Structural piece of timber. The member size means that it can be classified as a Post and Timber. The design values for Select Structural Douglas-fir Post and Timber can be obtained in table 4D of the NDS Supplement. Inspection notes indicate that there was easy access to all sides, so no uncertainty factor is applied. Estimated design values for member 8 are given in the far right column of Table 6.15.

### Assigning Estimated Design Values for Species Not Found in the NDS Supplement

If the species of the member is not in the NDS Supplement, design value estimates are even more uncertain. Strength and stiffness information on that species must be found. If small clear wood test values are available for the species you have identified, using the methods listed in ASTM D 245 as a guide, the equation

$$F_x = (\text{Property}) \cdot \frac{1}{\text{adjfac}} \cdot \text{Grade} \cdot \text{MC} \cdot \text{Size} \cdot \text{Un}$$

will allow for a design value estimate of  $F_x$ , which is the particular member property times an adjustment for duration of load and factor of safety (adjfac), grade (Grade), moisture content (MC), size (Size), and uncertainty (Un).

For bending, tension, shear, and compression parallel to grain design values, the estimated 5th percentile for each property is needed to estimate the design value. The 5th percentile for the species can be estimated by the  $(\text{Avg} - 1.645\sigma)$ , where Avg is the average green small clear strength value for the small clear test result in Table 6.1 and  $\sigma$  is the standard deviation for the species. The standard deviation can be approximated by using the average coefficient of variation for most wood properties (given in Table 6.16) times the average clear wood strength. The species' mean clear wood modulus of elasticity (MOE) and compression perpendicular to grain ( $C_{\text{perp}}$ ) stress values can be used to determine an estimate of MOE and  $C_{\text{perp}}$  design values.



**Table 6.16—Average coefficient of variation for clear wood properties (FPL 2010)**

	Bending	Modulus of elasticity	Tensile strength perpendicular to grain	Compressive strength parallel to grain	Horizontal shear strength	Proportional limit stress at deformation in compression perpendicular to grain
Coefficient of variation	16	22	25	18	14	28

**Table 6.17—Adjustment factors to be applied to the clear wood properties (ASTM D 245-11)**

	Bending	Modulus of elasticity	Tensile strength parallel to grain	Compressive strength parallel to grain	Horizontal shear strength	Proportional limit stress at deformation in compression perpendicular to grain
Softwoods	2.1	0.94	2.1	1.9	2.1	1.67
Hardwoods	2.3	0.94	2.3	2.1	2.3	1.67

**Table 6.18—Assumed strength ratio values for rough estimate of design values (Bendtsen and Galligan 1978)**

Grades	Assumed strength ratio					
	Bending	Tension	Shear	$C_{perp}$	Compression	MOE
Clear wood	100	100	100	100	100	100
Select Structural	65	65*55	50	100	69	100
No. 1	55	55*55	50	100	62	100
No. 2	45	45*55	50	100	52	90
No. 3	26	26*55	50	100	33	80

The adjustment factors (adjfac) suggested in D 245 for various clear wood properties are given in Table 6.17. This factor is meant to account for duration of load and a safety factor.

The Grade adjustment is based on the assumed strength ratio for a particular visual grade. Estimated strength ratios for cross grain and density have been obtained empirically; strength ratios for other growth characteristics have been derived theoretically. Particular grades have had approximate strength ratios associated with them. The strength ratio estimates for Grade are given in Table 6.18.

The Size adjustment is based on a size adjustment factor applied to the bending clear wood value. This factor adjusts the small clear wood specimen test result obtained at a 2-in. dimension to the dimension of the member. The adjustment for size can be determined by using the member depth of the member  $d$  and

$$\text{Size} = \left(\frac{2}{d}\right)^{1/9}$$

Finally, as in previous examples, an uncertainty factor ( $U_n$ ) adjustment is recommended to reflect the uncertainty associated with determining the grade and condition of the member.

Most species not in the NDS supplement but used in wooden structures can be found in Table 6.1. Two examples from Table 6.6, dimension lumber member 6 and timber member 9, are given below. Other example calculations of design values using clear wood information can be found in Bendtsen and Galligan (1978).

### Member is Dimension Lumber Size

Table 6.19 shows steps for estimating design values for member 6. Member 6 of Table 6.6 was identified as a 2- by 6-in. American chestnut Structural Joist and Plank that had observable defects and a slope of grain that classified it as a No. 2 piece of dimension lumber. The average clear wood mean values for American chestnut from Table 6.1, which

**Table 6.19—Example of design value estimation for No. 2 American Chestnut 2 by 6**

Species	Estimated member size	Estimated member grade	Purpose	Property	Clear wood mean (lb/in <sup>2</sup> )	5th Pctl. Est.	adjfac <sup>a</sup>	Grade	MC	Size	Un <sup>b</sup>	Estimated design value (lb/in <sup>2</sup> )
American Chestnut	2 by 6	Sel. Str.	Str. J&P	$F_b$ (lb/in <sup>2</sup> )	5,655	4,170	2.3	0.45	1.53	0.894	0.8	900
				$F_t$ (lb/in <sup>2</sup> )	5,655	3,330	2.3	0.247	1.53	1	0.8	450
				$F_v$ (lb/in <sup>2</sup> )	800	615	2.3	0.5	1.36	1	0.8	145
				$F_{cperp}$ (lb/in <sup>2</sup> )	305	N/A	1.67	1	2.00	1	0.8	290
				$F_{c//}$ (lb/in <sup>2</sup> )	2,465	1,735	2.1	0.50	2.15	1	0.8	650
				$E$ (10 <sup>6</sup> lb/in <sup>2</sup> )	930,000	N/A	0.94	0.9	1.32	1	0.8	900,000

<sup>a</sup>adjfac, adjustment factor.

<sup>b</sup>Un, uncertainty.

have been converted to pounds per square inch, are in column 1. Where applicable, these values are adjusted to a 5th percentile estimate in column 2. The hardwood adjustment factors from Table 6.17 and the estimated grade strength ratio from Table 6.18 are in columns 3 and 4, respectively. Moisture adjustment factors for American chestnut from green to dry are available in table X1.1 of ASTM D 2555 and are listed in column 5. Only the bending stress value is adjusted for size in column 6. Inspection notes indicate that there was quite good access, resulting in an uncertainty factor of 0.8. The estimated design values for member 6 are given in far right column.

**Member is Timber Size**—Table 6.20 shows steps for estimating design values for member 9. Member 9 of Table 6.6 was identified as a 5- by 8-in. ash beam and stringer that had observable defects approximating a No. 2 grade timber. The average clear wood mean values for white ash from Table 6.1, which have been converted to pounds per square inch, are tabulated in column 1. Where applicable, these values are adjusted to a 5th percentile estimate in column 2. The hardwood adjustment factors from Table 6.17 and the estimated grade strength ratio from Table 6.18 are in columns 3 and 4, respectively. Moisture adjustment factors for white ash from green to dry are available in table X1.1 of ASTM D 2555 and are listed in column 5. Only the bending stress value is adjusted for size in column 6. Inspection notes indicate that only 70% of the member was accessible, so an uncertainty factor of 0.7 is applied to the estimate. Estimated design values for member 9 are given in far right column.

## Final Words of Advice for Design Value Estimation

This manual is meant to provide the reader with basic information about design value assignment to wooden members. It gives the inspector a basic method for estimating design value for members. The most accurate estimate of the in-place design value for a member would be obtained by employing a certified grader with extensive experience and knowledge of the various structural lumber grades. The field inspector, however, should be able to get a good sense of the quality of the members that are in the structure and determine if current members are in the “ball park” of capacity needed.

An inspector will often not be able to see a large portion of a member, and judgment will be required based on the quality of wood in members that are visible in accessible areas. Confidence in the condition of members also plays a big role. Keep good records indicating the amount of the member that was accessible and your confidence of the estimated grade. Design values for the member may require an adjustment based on your confidence in your determined grade. The uncertainty factor that has been applied in the example estimations is one such adjustment.

Decisions made by the inspector on the condition of a structure, based on the inspector’s analysis of calculations or technical data, are ultimately the responsibility of the inspector. Understanding the basis of the information or data upon which they rely is the primary responsibility of the inspector. This manual is based on publicly available

**Table 6.20—Example of design value estimation for No. 2 White Ash 5 by 8**

Species	Estimated member size	Estimated member grade	Purpose	Property	Clear wood mean (lb/in <sup>2</sup> )	5th Petl. Est.	adjfac <sup>a</sup>	Grade	MC	Size	Un <sup>b</sup>	Estimated design value (lb/in <sup>2</sup> )
White Ash	5 by 8	No. 2	B-S	$F_b$ (lb/in <sup>2</sup> )	9,570	7,055	2.3	0.45	1.57	0.857	0.7	1,500
				$F_t$ (lb/in <sup>2</sup> )	5,265	5,635	2.3	0.247	1.57	1	0.7	650
				$F_v$ (lb/in <sup>2</sup> )	1,350	1,040	2.3	0.5	1.41	1	0.7	225
				$F_{cperp}$ (lb/in <sup>2</sup> )	665	N/A	1.67	1	1.73	1	0.7	385
				$F_{c//}$ (lb/in <sup>2</sup> )	3,990	2,805	2.1	0.50	1.86	1	0.7	975
				$E$ (10 <sup>6</sup> lb/in <sup>2</sup> )	1,435,000	N/A	0.94	0.9	1.21	1	0.7	1,200,000

<sup>a</sup>adjfac, adjustment factor.

<sup>b</sup>Un, uncertainty.

information. Some of that information comes from grading rules published by various trade associations or grades identified within the *National Design Specification for Wood Construction*. The Federal Highway Administration and the USDA Forest Service, while providing financial and administrative support, are not responsible for the content or use of the information by individuals. Be aware that changes in grading rules occasionally take place, and the inspector is responsible to confirm what the current rules are.

### Must-Have Documents

There are three must-have documents for someone trying to estimate a design value. Be sure to obtain the most current editions.

- The National Design Specification (NDS) Supplement *Design Values for Wood Construction*, which lists all currently approved design values for visually graded lumber and timber
- ASTM standard D 2555 *Standard Practice for Establishing Wood Strength Values*
- ASTM standard D 245 *Standard Practice for Establishing Structural Grades and Related Allowable Properties for Visually Graded Lumber*

The NDS Supplement can be obtained from the American Wood Council, 222 Catocin Circle SE, Suite 201, Leesburg, VA 20175 ([www.awc.org](http://www.awc.org)). The ASTM standards can be obtained from ASTM International, 100 Barr Harbor Drive, P.O. Box C700, West Conshohocken, PA 19428–2959 ([www.ASTM.org](http://www.ASTM.org)).

### References

- Anthony, R.W.; Dugan, K.D.; Anthony, D.J. 2009. A grading protocol for structural lumber and timber in historic structures. *APT Bulletin*. 40(2): 3–9.
- ASTM. 2013. Annual book of standards, Vol. 04.10. West Conshohocken, PA: American Society for Testing and Materials.
- ASTM D 245–11. Standard methods for establishing structural grades for visually graded lumber.
  - ASTM D 2555–06. Standard methods for establishing clear wood strength values.
- AWC. 2012. National design specification (NDS) supplement: design values for wood construction 2012 edition. Leesburg, VA: American Wood Council.
- Bendtsen, B.A.; Galligan, W.L. 1978. Deriving allowable properties of lumber (A practical guide for interpretation of ASTM standards). Gen. Tech. Rep. FPL–GTR–20. Madison WI: U.S. Department of Agriculture, Forest Service, Forest Products Laboratory. 31 p.
- DOC. [Current edition]. American softwood lumber standard. Voluntary product standard PS–20. Washington, D.C.: U.S. Department of Commerce.
- Green, D.W.; Evans, J.W. 2001. Evolution of standardized procedures for adjusting lumber properties for change in moisture content. Gen. Tech. Rep. FPL–GTR–127. Madison, WI: U.S. Department of Agriculture, Forest Service, Forest Products Laboratory.

- Falk, R.H.; Maul, D.G.; Cramer, S.M.; Evans, J.; Herian, V. 2008. Engineering properties of Douglas-fir lumber reclaimed from deconstructed buildings. Res. Pap. FPL–RP–650. Madison, WI: U.S. Department of Agriculture, Forest Service, Forest Products Laboratory. 47 p.
- FPL. 2010. Wood handbook—wood as an engineering material. Gen. Tech. Rep. FPL–GTR–190. Madison, WI: U.S. Department of Agriculture, Forest Service, Forest Products Laboratory. 508 p.
- Gonzalez, J.M.; Morrell, J.J. 2012. Effects of environmental factors on decay rates of selected white- and brown-rot fungi. *Wood and Fiber Science*. 44(4): 343–356.
- Ivory, E.P.; White, D.G.; Upson, A.T. 1923. Standard grading specifications for yard lumber. Circular 296. Washington, DC: U.S. Department of Agriculture. 75 p.
- Lantz, S.F.; Falk, R.H. 1997. Feasibility of recycling timber from military industrial buildings. In: *The use of recycled wood and paper in building applications*. Proceedings 7286. Madison, WI: Forest Products Society: 41–48.
- Loferski, J.R.; Dolan, J.D.; Lang E. 1996. Determining mechanical properties by nondestructive evaluation and testing methods in wood buildings. In: Kelley, S.J., ed. *Standards for preservation and rehabilitation*. West Conshohocken, PA.: American Society for Testing and Materials: 175–185.
- Newlin, J.A.; Johnson, R.P.S. 1923. Basic grading rules and working stresses for structural timbers. Circular 295. Washington, DC: U.S. Department of Agriculture.
- Smith, L.W., Wood, L.W. 1964. History of yard lumber size standards. Madison, WI: U.S. Department of Agriculture, Forest Service, Forest Products Laboratory.
- SPIB. 2002. Standard grading rules for southern pine lumber. Pensacola, FL: Southern Pine Inspection Bureau.
- Wiedenhoeft, Alex C.; Kretschmann, David E. 2014. Species identification and design value estimation of wooden members in covered bridges. General Technical Report FPL–GTR–228. Madison, WI: U.S. Department of Agriculture, Forest Service, Forest Products Laboratory. 94 p.
- Wood, L.W. 1954. Structural values in old lumber. *Southern Lumberman*. No. 189, Dec. 15, part 2.
- WWPA. 2005. Western lumber grading rules. Portland, OR: Western Wood Products Association.

## Condition Assessment Report

Robert J. Ross

This chapter presents the complete condition assessment report for the Quincy Mine Blacksmith Shop in Hancock, Michigan. The assessment was conducted by Robert J. Ross, Project Leader, Condition Assessment and Rehabilitation of Structures, USDA Forest Service, Forest Products Laboratory, Madison, Wisconsin; Xiping Wang, Senior Research Associate, Natural Resources Research Institute, University of Minnesota Duluth, Duluth, Minnesota; John W. Forsman, Assistant Scientist, Michigan Technological University, Houghton, Michigan; and John R. Erickson, Director (retired), USDA Forest Service, Forest Products Laboratory, Madison, Wisconsin. The report was completed September 28, 2001.

### Condition Assessment of Timbers from Quincy Mine Blacksmith Shop—Scanning Timbers for Deterioration

#### Summary

Fifteen 12- by 12-in. white pine timbers removed from the Quincy Mine Blacksmith Shop were nondestructively evaluated at the USDA Forest Service, Forest Products Laboratory, through intensive stress wave scanning. The timbers were part of the original roof truss structure in the Blacksmith Shop. Scan results indicated that some timbers or some sections of the timbers had severely deteriorated and lost structural integrity. Most of the timbers still contained a substantial amount of solid wood, and some timbers were only slightly decayed or mechanically damaged. Further data analysis indicated that 61% of the total materials could be potentially recovered from these timbers and used in the reconstruction project.

#### Background

The Quincy Mining Company's Drill and Blacksmith Shop, located in the Keweenaw National Historical Park, was constructed in 1900 by the Quincy Mining Company. Of great interest is the preservation and use of the remaining roof trusses and floor joists. The 12- by 12-in. white pine roof truss timbers had been exposed to weather for several years. These structural members, manufactured from old-growth timber, are a tremendous resource that should be appropriately used in the renovation of the Drill and Blacksmith Shop.



Figure 7.1—Fifteen 12- by 12-in. white pine timbers removed from the Quincy Mine Blacksmith Shop.

Condition assessment of the heavy timbers from the Blacksmith Shop was an important first step in the restoration of this structure. An early on-site assessment found that a substantial amount of timbers contained solid wood in spite of visually observed deterioration of parts of the members. The intent of this assessment was to follow up on the promising cursory assessment results and to further nondestructively evaluate selected white pine timbers in the laboratory.

#### Objectives

The objectives of this assessment were as follows:

1. To detect the location and severity of deterioration in 12- by 12-in. white pine timbers removed from the Quincy Mine Blacksmith Shop through intensive scanning using a stress wave transmission technique
2. To determine how much of the original structural wood from these timbers can be potentially recovered and used in the reconstruction project

#### Materials and Method

Fifteen 12- by 12-in. white pine timbers removed from the Quincy Mine Blacksmith Shop were transported to the USDA Forest Service, Forest Products Laboratory (FPL) in Madison, Wisconsin, on August 2, 2001 (Fig. 7.1). The timber specimens ranged from 25.5 to 50 ft in length; 13 of the specimens were about 50 ft long (originally used

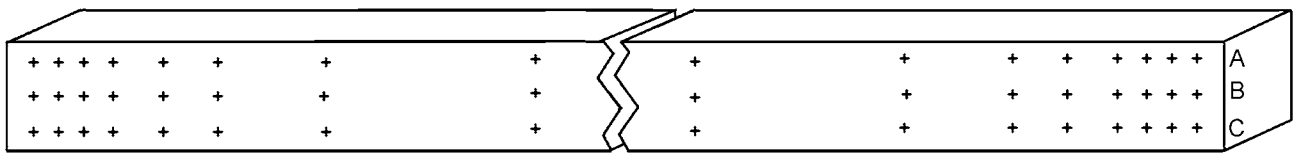


Figure 7.2—Scanning diagram for nondestructive evaluation of 12- by 12-in. white pine timbers.

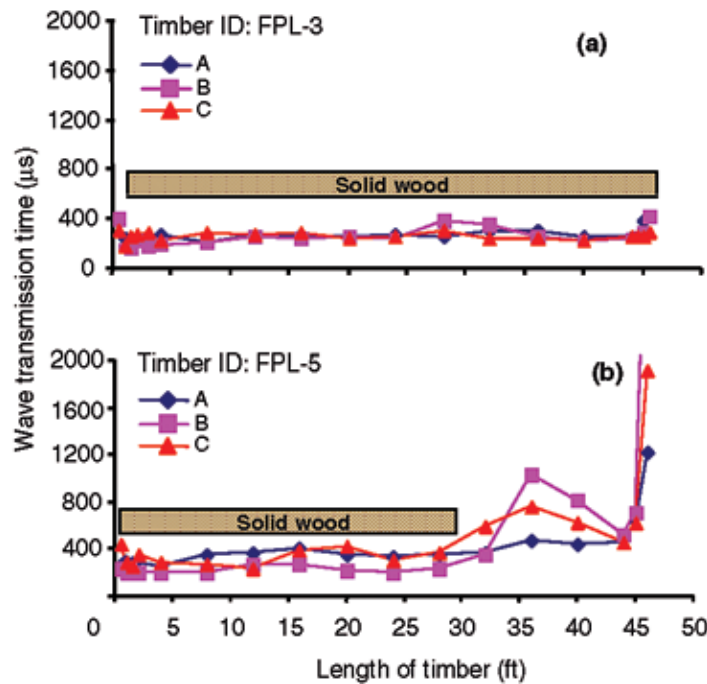


Figure 7.3—Typical scan results from 12- by 12-in. white pine timbers.

as tension members in the roof trusses) and 3 of the specimens were from 26 to 34 ft long (probably used as pitched chord or web materials). These timbers were part of the original roof structures and had been exposed to weather for several years. Surface decay, splits, mechanical damage, and notches were the major defects observed (App. A).

Figure 7.2 shows a typical scanning diagram used to conduct stress wave transmission tests. The timbers were supported on two beams. Each timber was stress wave scanned along three lines (upper line A, middle line B, and lower line C) on the side surfaces through the height of each timber. Because the ends of the timber were usually considered to be the areas having a high risk of decay, stress wave transmission tests were more intensively performed at ends than other parts of the timber. Intervals between the two scanning points in the longitudinal direction changed from 6 in. beginning at the end of the timber to 1, 2, and 4 ft, respectively, as the scanning position approached the middle part of the timber.

A commercially available stress wave timing unit was used to measure wave transmission time, perpendicular to grain,

at a series of points as described above (described in detail in FPL (2000)). Three stress wave readings were taken at each scanning point, and the average wave transmission time for each point was used as an indicator of the soundness of wood in that area.

## Results

Results obtained from stress wave scans are shown in Figure 7.3. Stress wave transmission time measured perpendicular to grain was in microseconds. Given the same width of 12 in. for all timbers, the stress wave data expressed on the y axis can also be deemed as values in a unit of microseconds per foot ( $\mu\text{s}/\text{ft}$ ). Therefore, scan results for all 15 timbers can be conveniently compared with baseline data given in previous publications (Ross and Pellerin 1994; Ross et al. 1998, 2001; FPL 2000; Clausen et al. 2001).

Stress wave transmission time may vary from species to species, but it is mainly controlled by the soundness of wood in terms of deterioration detection. For most species, stress wave transmission time perpendicular to grain ranges

**Table 7.1—Potential recovery of solid wood from 12- by 12-inch (30- by 30-cm) white pine timbers**

Timber ID	Length of timber (ft) <sup>a</sup>	Length of solid material (ft) <sup>a</sup>	Potential recovery (%)	Major defects of timber
FPL-1	50	39	78	Decay on end, notch
FPL-2	48.4	28	58	Surface check
FPL-3	45.8	45	98	—
FPL-4	50	8	16	Severe decay, split, notch
FPL-5	47.8	28	59	Decay on end, surface check, notch
FPL-6	50	42	84	Decay on end, surface check, notch
FPL-7	50	26	52	Decay, notch
FPL-8	46	8	17	Severe surface decay
FPL-9	50	42	84	Surface check, notch
FPL-10	48.3	44.5	92	Surface decay on one end
FPL-11	50	24	48	Severe decay, notch
FPL-12	25.5	0	0	Severe decay, split, notch
FPL-13	33.8	22	65	Split on ends
FPL-14	32	16	50	Decay and split on ends, notch
FPL-15	50	24	48	Severe decay, notch

<sup>a</sup>1 ft = 0.3 m.

from 180 to 400  $\mu$ s/ft for solid wood (FPL 2000). This baseline range was used as an evaluation standard to assess scan results obtained from the fifteen 12- by 12-in. white pine timbers.

As shown in wave transmission-time/length-of-timber graphs, these white pine timbers are in various conditions, from solid, to slightly to severely deteriorated, to almost fully deteriorated. Deterioration was mainly caused by decay (surface and internal), splits, and mechanical damage. From scans shown in Figure 7.3, it is possible to distinguish whether deterioration occurs in surface areas or inside the timber as stress wave transmission times obtained from three scan lines (A, B, and C) are plotted on the same graph for each timber.

The solid wood in each timber was determined by comparing scan results with baseline data of stress wave transmission times for solid wood. The approximate length of solid wood for each timber that could have potential structural uses was also determined and indicated below each scan graph. A summary of potential recovery of the solid wood from all tested white pine timbers is detailed in Table 7.1.

From the scans and Table 7.1, it is evident that a substantial amount of solid wood could be recovered from these timbers except for one short timber, FPL-12, which was almost fully deteriorated. Potential recovery rate could be as low as 16% to 17% because of severe deterioration found in timbers (such as FPL-4 and FPL-8); it could also be as high as over 90% (such as timber FPL-3 and FPL-10). Overall, an average of 61% of total materials (not including FPL-12) could be potentially recovered from these white pine timbers and used in the reconstruction project.

## Conclusions and Recommendations

Fifteen 12- by 12-in. white pine timbers removed from the Quincy Mine Blacksmith Shop were nondestructively evaluated through intensive stress wave scanning. The scan results indicated that some timbers or parts of timbers had seriously deteriorated and lost structural integrity. It was also found that most of the timbers still contain a substantial amount of solid wood, and some timbers were only slightly decayed or mechanically damaged on the ends. Further data analysis indicated that overall 61% of the total materials could be potentially recovered from these timbers and used or displaced in the reconstruction project.

Three recommendations were based on preliminary results obtained from the 15 white pine timbers:

1. Complete stress wave scanning tests on the remaining white pine timbers, including 12- by 12-in. roof truss timbers and 3- by 14-in. floor joists. Use the same procedure as employed in this assessment to determine location and severity of deterioration that might occur in the remaining structural members.
2. Cut off deteriorated sections from the timbers and obtain solid material based on scan results.
3. Mechanically proof-load all solid wood sections to supply engineering design values for their reuse in the reconstruction project.

## References

Clausen, C.A.; Ross, R.J.; Forsman, J.W.; Balachowski, J.D. 2001. Condition assessment of Quincy Mine Blacksmith Shop in Keweenaw National Historical Park. Res.

Note FPL–RN–0281. Madison, WI: U.S. Department of Agriculture, Forest Service, Forest Products Laboratory. 4 p.

FPL. 2000. Stress wave timing nondestructive evaluation tools for inspecting historic structures. Gen. Tech. Rep. FPL–GTR–119. Madison, WI: U.S. Department of Agriculture, Forest Service, Forest Products Laboratory. 15 p.

Ross, R.J.; Pellerin, R.F. 1994. Nondestructive testing for assessing wood members in structures: A review. Gen. Tech. Rep. FPL–GTR–70 (Rev.). Madison, WI: U.S. Department of Agriculture, Forest Service, Forest Products Laboratory. 40 p.

Ross, R.J.; Soltis, L.A.; Otton, P. 1998. Assessing wood members in the USS Constitution using non-destructive evaluation methods. *APT Bulletin (The Journal of Preservation Technology)*. 29(2):21-25.

Ross, R.J.; Pellerin, R.F.; Forsman, J.W.; Erickson, J.R.; Lavinder, J.A. 2001. Relationship between stress wave transmission time and compression properties of timbers removed from service. Res. Note FPL–RN–280. Madison, WI: U.S. Department of Agriculture, Forest Service, Forest Products Laboratory. 4 p.



## Appendix A—Major Defects Observed in 12- by 12-inch White Pine Timbers



Surface decay



Severe decay damage



End decay



End decay



Large, deep check



**Surface decay and multiple cracks**



**Mechanical damage**

## Summaries from Actual Inspections

**Robert J. Ross**

This chapter presents summaries of inspections from a wide range of structures, from a sports stadium to a mummy coffin. Included are a brief overview of the structure, its location, a brief history of the structure, and several photographs. Note that these were selected to emphasize the broad range of structures that can be inspected using the techniques presented in earlier chapters. Most include a photo of the structure, visual observations, and equipment in use. No attempt is made to discuss repairs made or other actions taken based on inspection results. Citations for papers prepared based on the inspections are included, if available, for further details.

### Washington State University Football Stadium

Structure: Martin Stadium

Location: Pullman, Washington

Special Consideration(s): Arid environment

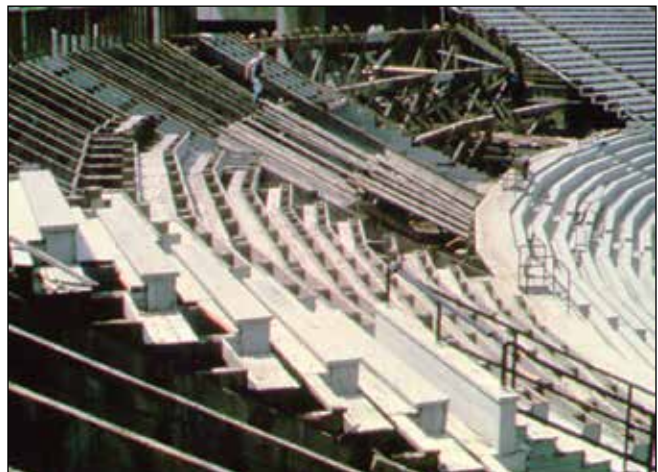
Brief history of structure:

Estimated age: 50 years at time of inspection

Inspection date: 1982

Construction details: Heavy timber, creosote-treated Douglas-fir

Washington State University's football stadium was inspected using visual, coring, and stress wave timing techniques. This stadium was originally constructed in the 1930s; the north and south grandstands were replaced after a fire in the 1960s. In the early 1980s, the structural integrity of the horseshoe section that joined the north and south grandstands was inspected. This horseshoe section was part of the original stadium and was constructed from large solid-sawn timbers. An informal inspection revealed that the structural members in the horseshoe section were badly decayed. Further evaluation using stress wave timing equipment showed that speed-of-sound transmission was significantly lower in decayed members than in sound wood. Subsequent probing of those areas indicated that the decay was so extensive that only a thin shell of sound wood remained. These results led to the dismantling of the horseshoe section of the stadium.





## Grangeville and Kooskia High School Gymnasiums

Structure: School gymnasiums

Location: Grangeville, Idaho; Kooskia, Idaho

Special Consideration(s): None

Brief history of structure:

Estimated age: 20 years at time of inspection

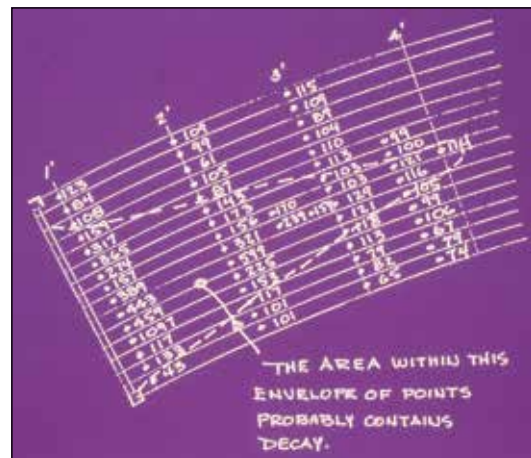
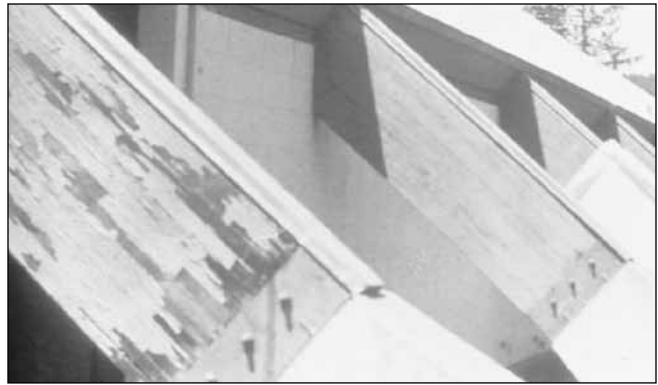
Inspection date: 1975

Construction details: Series of curved, glued-laminated timber arches

Two school gymnasiums constructed with laminated barrel arches were evaluated. These glued-laminated arches were the main support structure for the gymnasiums. Each arch end was exposed to the weather and rested in a metal shoe (which was closed, so the water could not drain properly) fastened to a concrete pier foundation. These conditions and the heavy nonbreathing paint that was used on the exposed portions of the arches created an environment that would support the growth of decay fungi. Cracking and peeling paint were the first indications that decay was present in the arch ends. When school personnel realized the condition of the gymnasium, the problem was one of determining where decay was present and where the wood was sound and did not require replacement. It was not necessary to pinpoint the decayed areas with great precision but to establish how far in from the arch ends that decay had progressed. The repair procedure was then to replace those arch ends with structurally sound material.

The primary inspection method used was stress wave timing. Inspectors used two papers containing grids attached to each side of the arch as a map for taking stress wave timing measurements. The recorded times were then used to determine the extent of decay.

Hoyle, R.J.; Pellerin, R.F. 1978. Stress wave inspection of a wood structure. *In*: Proceedings, 4th symposium on nondestructive testing of wood. Pullman, WA: Washington State University: 33–45.



## Peshtigo River Timber Bridge

Structure: Timber bridge

Location: Chequamegon-Nicolet National Forest, Laona, Wisconsin

Special Consideration(s): None

Brief history of structure:

Estimated age: 40 years

Inspection date: 2001

Construction details: Five span, heavy timber construction, creosote-treated Southern Pine pilings, creosote-treated Douglas-fir pile caps, girders, and decking

A detailed inspection of this traditional heavy timber bridge was completed to evaluate the quality of individual members as part of the bridge inspection system. Visual inspection, sounding, and moisture content techniques were used to identify decay and subsequent carpenter ant damage to timber piles on the bridge abutment. The Southern Pine pilings showed shell damage caused by ice and damage due to flotsam. The use of a snooper vehicle allowed for detailed inspection of individual girders, pile caps, and pilings in each of the five spans. Two exterior girders and one pile cap with substantial decay were located and mapped using sounding, stress wave timing, and moisture content techniques. Confirmation of shell thickness was completed using increment coring. Members were identified for replacement.



## C.A. Thayer

Structure: Three-masted schooner

Location: San Francisco Maritime National Historical Park, San Francisco, California

Special Consideration(s): Inspection was conducted as part of a preservation effort

Brief history of structure:

Estimated age: 106 years

Inspection date: 2001

Construction details: Douglas-fir, heavy timber construction

The C.A. Thayer was launched in 1895 as a lumber carrier. During her working career, the C.A. Thayer made 113 voyages: 13 in the salmon trade, 12 as a cod fishing boat, and 88 as a lumber carrier. All but a handful of the lumber voyages began and ended at Hoquiam, Washington, on Gray's Harbor. She also delivered lumber to Honolulu, Mexico, and the Fiji Islands.

During the summer of 2001, an inspection of the keel and mizzenmast of C.A. Thayer was conducted. Visual and stress wave techniques were used. The keel was found to be sound, with a small area of deterioration just below the bowspirit support. Deterioration, mechanical and decay, was found in the mizzenmast at the deck line.

### References

Ross, R.J.; Kirchner, J.; Wang, X.; Forsman, J. 2001. Inspection of keel and mizzenmast on C.A. Thayer. Research Report, USDA Forest Service, Forest Products Laboratory, Madison, WI.



## Esterhazy Castle

Structure: Esterhazy Castle

Location: Sopron, Hungary

Special Consideration(s): Castle complex was damaged during World War II and was minimally maintained after the War

Brief history of structure:

Estimated age: 200+ years, the castle was constructed from 1720 to 1800

Inspection date: 2000

Construction details: Traditional European heavy timber construction

Rehabilitation efforts for this structure have begun. Its roof system was visually inspected in 2000. The traditional mortise and tenon timber framing system was found to be in excellent condition. Stains from water exposure and subsequent decay were evident in several locations where timbers were in direct contact with masonry.





## Grey Towers National Historic Landmark

Structure: Mansion

Location: Milford, Pennsylvania

Special Consideration(s): None

Brief history of structure:

Estimated age: 108 years at time of inspection

Inspection date: 1994

Construction details: Timber and masonry

Located in the Pocono Mountains of northeastern Pennsylvania, this mansion overlooks the Delaware River Valley and the small town of Milford. Designed by Richard Morris Hunt, the chateausque summer mansion was completed in 1886.

In 1994, as part of an ongoing restoration effort, an inspection was conducted. Visual, stress wave, and coring techniques were utilized. Significant water damage was observed in several areas of the mansion. Floor joists supporting the structure's kitchen were severely degraded. Several joists were so deteriorated that little or no contact was observed between them and the masonry foundation.



# USS Constitution

Structure: Three-masted battleship

Location: Boston, Massachusetts

Special Consideration(s): None

Brief history of structure:

Estimated age: 200+ years

Inspection date: 1991, 1992

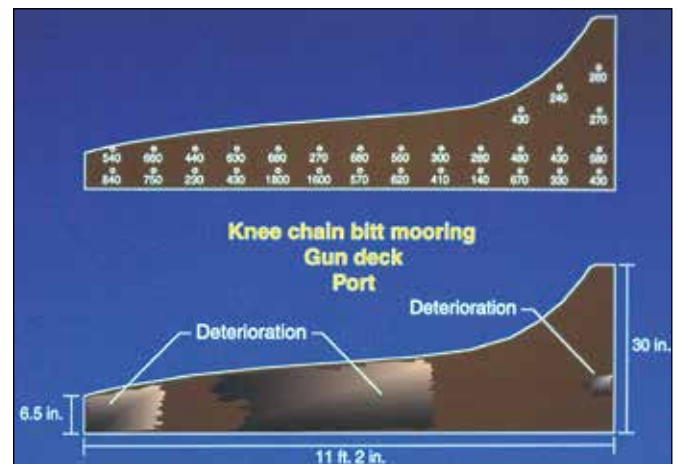
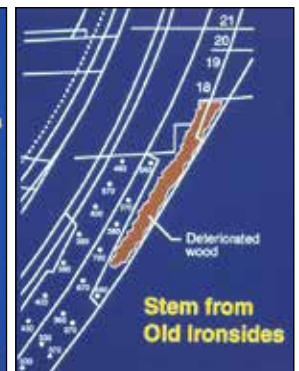
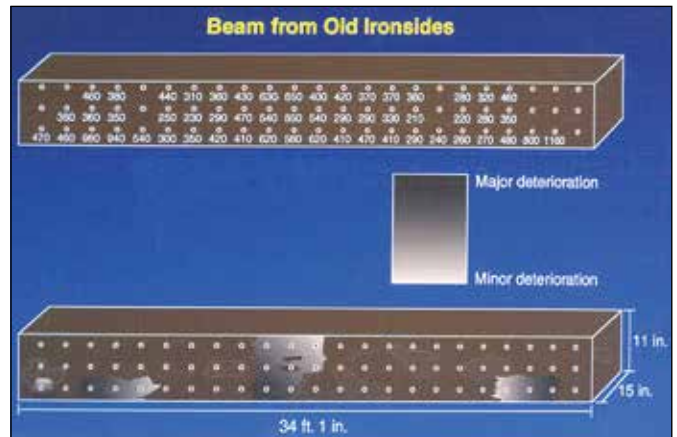
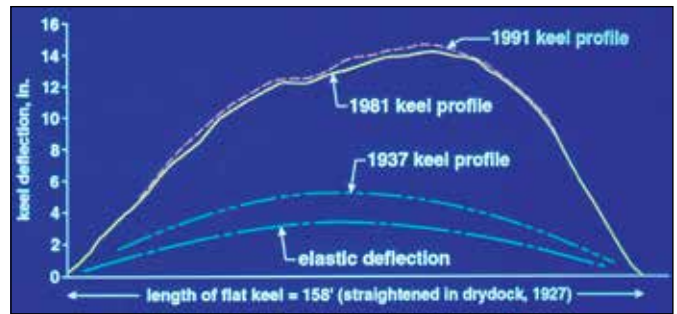
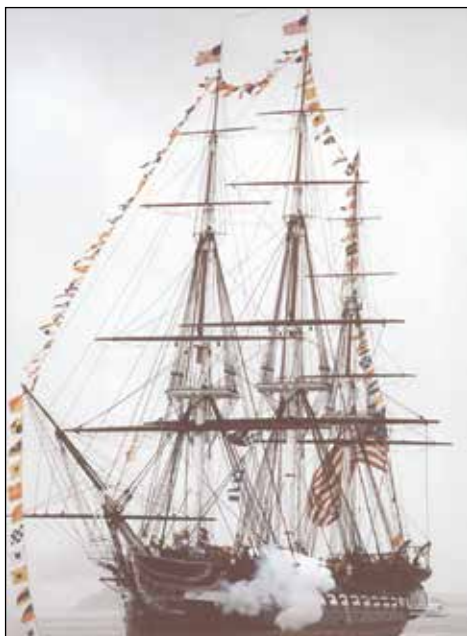
Construction details: Heavy timber, live oak

The USS Constitution, “Old Ironsides,” was launched on October 21, 1797. She is the oldest commissioned ship afloat in the world. She carries this distinction based on the fact that a significant portion of the ship’s underwater structure is original. Included in this original material are the keel, deadwood, floors, lower planking strakes, and a number of lower frame futtocks. During the 1990s, the U.S. Navy conducted an intensive assessment of the condition of the ship. The sophistication of these tests ran the gamut from signs of deterioration observed through visual inspection to instrumented probes and advanced chemical analyses. Mechanical and decay deterioration was observed. Several members were repaired.

## References

Ross, R.J.; Soltis, L.A.; Otton, P. 1998. Assessing wood members in the USS Constitution using non-destructive evaluation methods. APT Bulletin (The Journal of Preservation Technology). XXIX(2):21–25.

Witherell, P.W.; Ross, R.J.; Faris, W.R. 1992. Using today’s technology to help preserve USS Constitution. Naval Engineers Journal. 104(3):124–134.



## Mummy Coffin

Structure: Mummy coffin

Location: Nelson–Atkins Museum of Art, St. Louis, Missouri

Special Consideration(s): Historically important Egyptian artifact

Brief history of structure:

Estimated age: 2,500 years at time of inspection

Inspection date: 2009

Construction details: Natural paints, timber joinery

The country of Egypt provides us with some of the best-preserved wood artifacts because of several factors. First, despite the paucity of indigenous trees capable of producing wood in sufficient sizes to make large timbers, ancient Egyptians used wood extensively in a wide variety of applications. Second, the arid climate in Egypt provides an excellent environment for long-term preservation of wood. As a consequence, excavations of various archeological sites in Egypt have yielded many well-preserved wood artifacts.

Mummy coffins are the best examples of Egyptian wood artifacts. As some of the most precious, ancient pieces at

the largest museums in the world, mummy coffins provide scientists very important information about social, religious, and cultural beliefs of ancient Egyptians. This wood mummyform coffin, dated to the first millennium B.C., is part of a group of funerary objects acquired by the museum in 2007 and put on display in a newly designed gallery space. The assessment was conducted to provide information on the condition of the coffin to museum staff responsible for designing and constructing appropriate support mechanisms for its display.

The coffin was constructed from sycamore fig trees, *Ficus sycomorosa*. This tree species was known as the “tree of life” in ancient Egypt and was cultivated commonly. Visual inspection and stress wave techniques were used to assess the condition of the upper and lower portions of the coffin. Much of the wood was solid, with no deterioration present. Estimates of several important properties (modulus of elasticity, modulus of rupture, compression parallel to grain) were made.

### Reference

Ross, R.J.; Dundar, T. 2012. Condition assessment of 2500 year old wood coffin. Res. Note FPL-RN-0327. Madison, WI: U.S. Department of Agriculture, Forest Service, Forest Products Laboratory: 3 pp.



## Steam Schooner WAPAMA

Structure: Wooden steam-powered schooner

Location: California State Historical Maritime Park, California

Special Consideration(s): Last surviving example of wooden steam-powered schooners designed for the 19th- and 20th-century Pacific Coast lumber trade and coastal service

Brief history of structure:

Estimated age: 91 years at time of inspection

Inspection date: 2006

Construction details: Built almost entirely of old-growth Douglas-fir timber, approximately 217 ft long and 50 ft from keel to house top, with a gross tonnage (or internal volume) of 945 GT. Its construction is unique in its use of sister frames and lack of steel strapping. The hull is single decked and characterized by a plum stem, full bows, straight keel, moderate deadrise, and an easy turn of bilge.

A variety of nondestructive test methods were employed to locate problem areas and define the severity of deterioration on key structural members such as keelsons, keel, ceiling planking, hull frames, clamps, and main deck beams. Mechanical and decay-related deterioration was found in several members. They were subsequently replaced.

### References

Wang X.; Wacker, J.P.; Ross, R.J.; Brashaw, B.K. 2008. Condition assessment of the main structural members of historic steam schooner Wapama. Res. Pap. FPL-RP-649. Madison, WI: U.S. Department of Agriculture, Forest Service, Forest Products Laboratory.





