

Bully Dog Technologies, LLC is a team built on integrity that is dedicated to leading the vehicle performance industry with an uncompromising code of ethics demonstrated in the soundness of its employees, excellent customer service and superior products.

UNLEASH THE POWER

WITH BULLY DOG PERFORMANCE PRODUCTS

Downloaders



Intake Systems



OutLook Monitor



Custom Outlook Pod

See More at: bullydog.com

Doc.# BD81006 v1.0.1

For a full listing of Diagnostic Trouble Codes go to: www.bullydog.com/DTC.php



BULLY DOG

For Free Technical Support

Call: 866-bullydog (866-285-5936)



BULLY DOG

#1 IN PERFORMANCE

INSTALLATION MANUAL



Vehicle Application	Part#
Rapid Flow 5" Aluminized Exhaust 6.0L Ford Power Stroke '03-'07	181052





TROUBLESHOOTING:

If you have questions during the installation of this product, please visit www.bullydog.com/Product_Updates.php.

The latest version of these instructions can be found at the same location. Please review the Troubleshooting section on page 9 before calling technical support to cover most common issues. Technical support is available by calling 866-bullydog (866-285-5936).

TABLE OF CONTENTS

INTRODUCTIONS	PG 2
BILL OF MATERIALS	PG 3
EXHAUST REMOVAL	PG 4
EXHAUST INSTALLATION.....	PAGES 5-8
Quick Location Overview	PG 5
Installation Steps.....	PGS 6-8
TROUBLESHOOTING.....	PG 9
WARRANTY & DISCLAIMER	PG 10

INTRODUCTION

The Bully Dog Rapid Flow Exhaust Systems have been specially designed to allow the lowest mandrel bends in the industry. The lower mandrel bends allow increased air flow which reduces exhaust temperatures, burns more fuel in the combustion chamber adding additional horsepower and fuel economy. This instruction set covers the 5" Rapid Flow Aluminized Exhaust for the 6.0L Ford Power Stroke.

Note: This instruction set and the Rapid Flow Exhaust system included is made exclusively for the 6.0L Ford Power Stroke '03-'07.

BULLY DOG'S RULE OF THUMB FOR EXHAUST SIZES

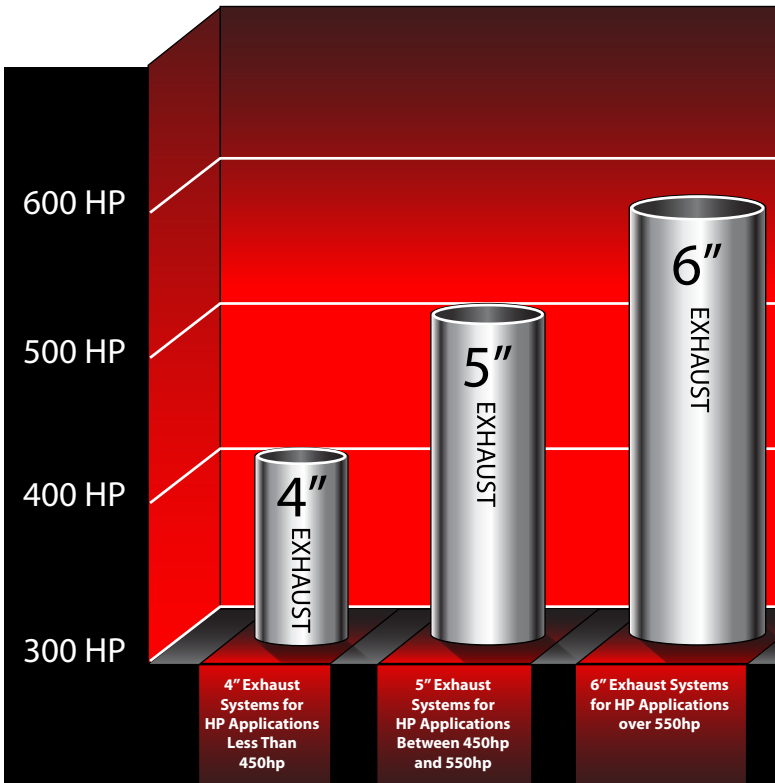

BILL OF MATERIALS

1. Down Pipe
2. Second Piece Down Pipe
3. 48" Straight pipe
4. 24" Straight Pipe
5. Muffler
6. Front Piece Tail Pipe
7. Tail Pipe Tip
8. Adapter
9. Clamps (7 Pieces)
10. Hangers (4 Pieces)

A. Second Piece Down Pipe Hanger

B. Straight Pipe Hanger

C. Rear of Muffler Hanger

D. Tail Pipe Tip Hanger

TOOLS NEEDED

- 7/16" Wrench
- 9/16" End Wrench
- Sawzall (Recommended)
- Silicone Spray Lubricant
- Channel Locks

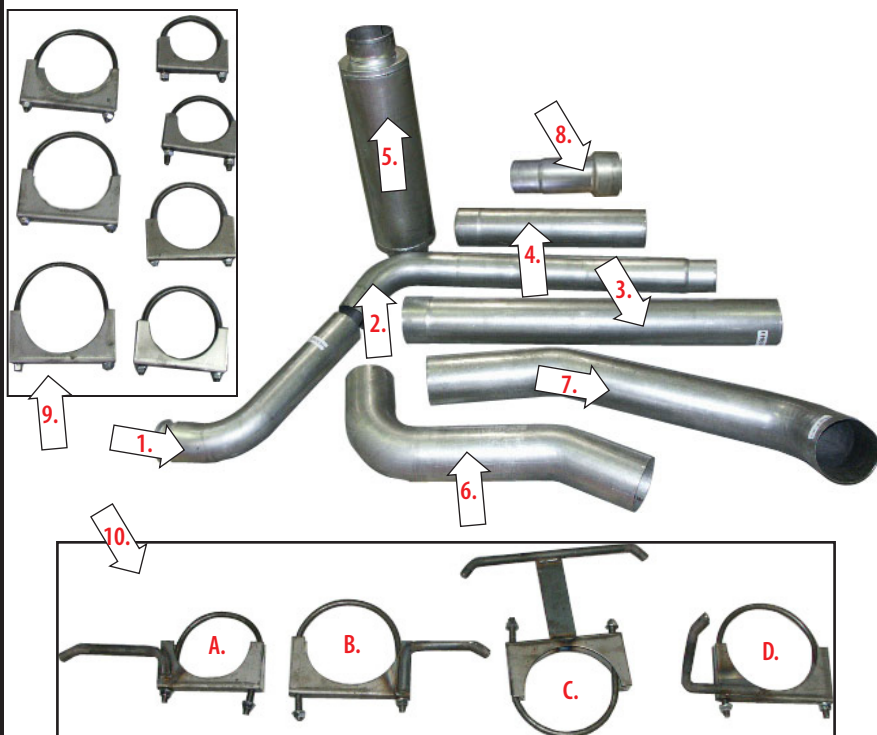

REMOVAL OF STOCK EXHAUST SYSTEM

In these steps you will remove the stock exhaust system.

IMPORTANT: It is illegal in all 50 states to remove the catalytic converter.

1. Use a sawzall to cut the exhaust immediately behind the muffler.
2. Then cut the exhaust 4 inches behind the catalytic converter in front of the band clamp.
3. Next cut the exhaust 4 inches in front of the catalytic converter.
4. Then make a cut at the bottom of the down pipe.
5. Finally cut the bolt on the firewall so that the new down pipe will fit.
6. Use a 7/16" deep socket to loosen the stock bank clamp at the top of the stock down pipe. The stock band clamp will be reused, so you will not need to completely remove it.
7. Remove each piece of the stock exhaust system, including the stock hangers. To make removal the hangers easier, it is recommended that you use a silicone spray on each of the rubber hangers that hold the stock exhaust.



#1 Cut Exhaust after muffler



#2 Cut Exhaust in front of band clamp



#3 Cut in front of Catalytic Converter



#5 Cut Firewall Bolt



#7 Remove necessary exhaust hangers



#4 Cut at Bottom of Down Pipe

RAPID FLOW INSTALLATION

Introduction

Bill of Materials

Exhaust Removal

Exhaust Installation

Troubleshooting/FAQ

Warranty/Disclaimer

QUICK OVERVIEW FULL EXHAUST

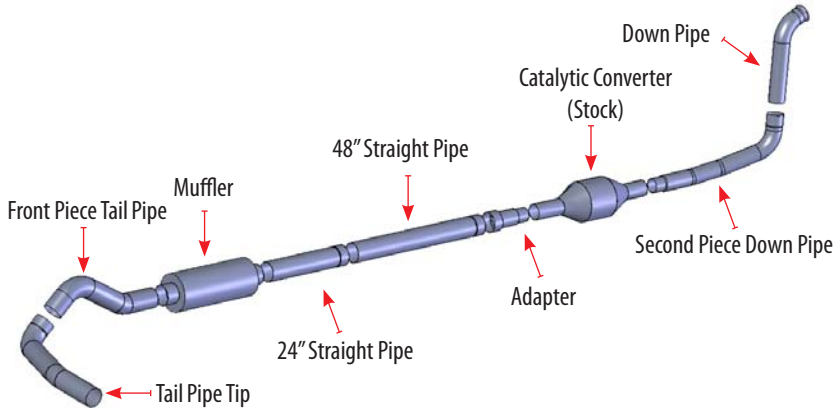

CLAMP AND HANGER PLACEMENT

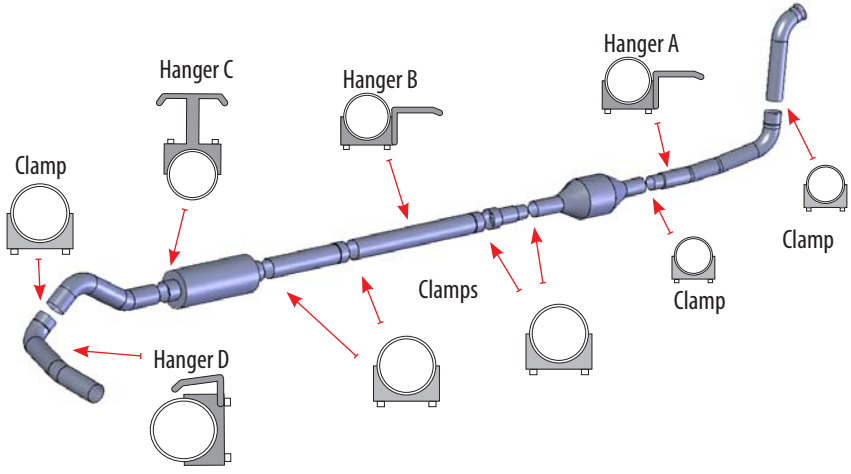

INSTALLATION OF THE BULLY DOG RAPID FLOW EXHAUST SYSTEM

In these steps you will install the Rapid Flow Exhaust System. Bully Dog's Exhaust Systems are one-cut system, meaning that you should only have to cut one pipe or less if installed correctly.

IMPORTANT: Do Not over-tighten Clamps. Too much torque will result in deformation of the exhaust. For best results when doing the installation, tighten the Clamps enough to hold the exhaust pieces in place, but don't tighten down until the entire exhaust system is installed.

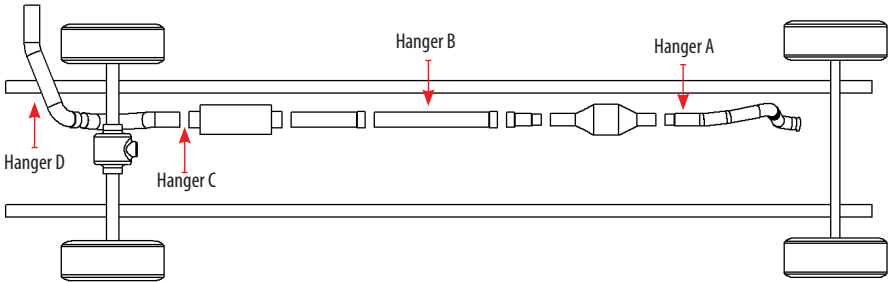

1. It is suggested that before installing the system on the truck, the Rapid Flow Exhaust be laid out on a large flat surface to acknowledge the location of each piece.
2. Place all of the supplied Hangers into their appropriate locations as shown in the above diagram. Hanger A will be located on the 2nd Piece Down Pipe. Hanger B will be located on the Straight Pipe. Hanger C will serve as both a hanger and a clamp at the rear of the Muffler and Hanger D will hold the Tail Pipe Tip.
3. Install the Down Pipe. You will use the stock band clamp to secure the Down Pipe to the turbo. Secure the Down Pipe by tightening the stock band clamp with a 7/16" deep socket.

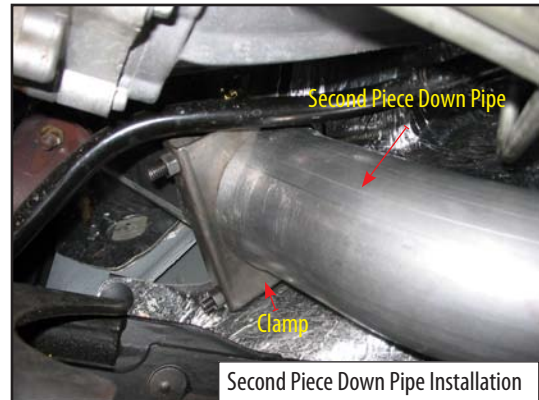
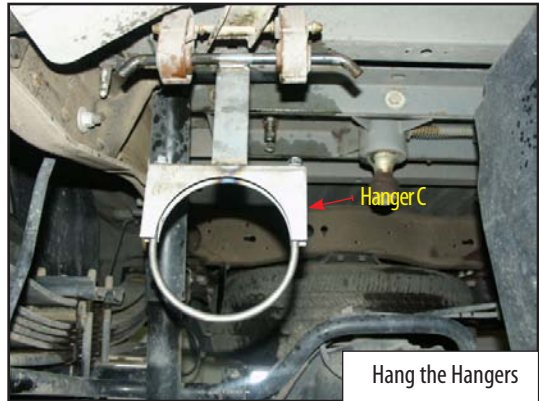

4. Hang the Second Piece Down Pipe from Hanger A and secure it to the Down Pipe by using one of the supplied clamps. At this point, secure the connection so that the piece will stay, but do not tighten down until the entire exhaust is installed.
5. Reinstall the Catalytic Converter and secure with one of the supplied clamps.
6. Install the Adapter on the Catalytic Converter and secure with one of the supplied clamps.

Note: At this point, you will skip installing the Straight Pipes and Muffler and continue to work towards the rear for the vehicle.

7. Join together the Front Piece Tail Pipe and the Tail Pipe Tip.
8. Hang the combined pieces from Hangers C and D. Ensure that the bend of the Front Piece Tail Pipe is directly over the axle. Secure the connection between the two exhaust pieces with a clamp.
9. Install the Muffler by connecting it to the Front Piece Tail Pipe and then tightening Hanger C.
10. At this point it is time to install the Straight Pipe(s). Extra straight pipes are included depending on the configuration of your vehicle. Keep in mind when you make your measurements that you will need to leave an extra 3 inches of overlap when you cut the straight pipe.

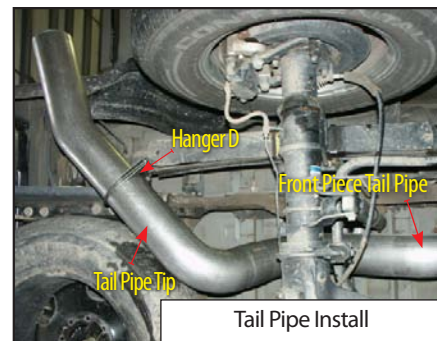
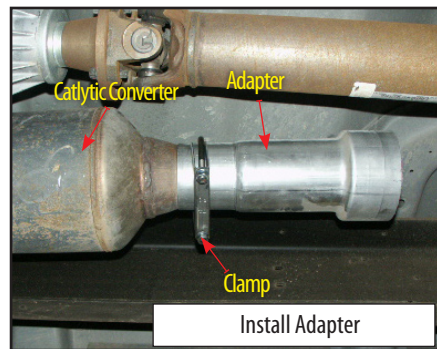
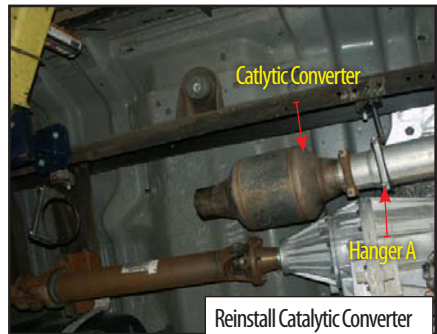

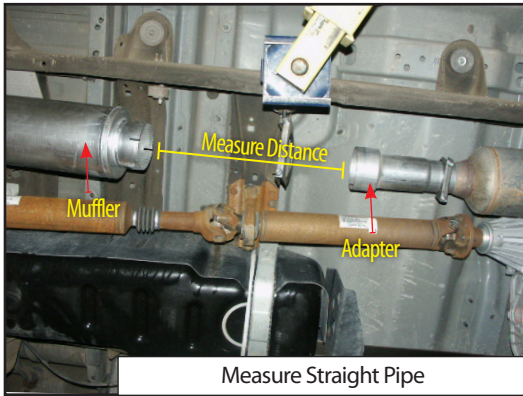

11. Once the entire exhaust system is installed, inspect the system to ensure that no part of the exhaust is in direct contact with the chassis or body; adjustments may be necessary.

12. Return to each of the Clamps and tighten with a 9/16" wrench. Again, do not over tighten Clamps. Having any part of the exhaust system in direct contact with any part of the body or chassis will cause the exhaust to rattle.

13. Stainless Steel Tips are available from Bully Dog to give your truck that polished, classy, look.



5" Stainless Tip
Part Number: 180295



5" to 6" Stainless Tip
Part Number: 180566

TROUBLESHOOTING/FAQ

CONDITION	POSSIBLE SOURCES	ACTION
Which is better a 4" exhaust or a 5" exhaust system?	General	It really depends on the application. A bigger exhaust system will allow more airflow and lower exhaust temperatures. However too large of an exhaust system without other increases in horsepower will lower back pressure and give the vehicle a sluggish start. Bully Dog recommends a 4" Rapid Flow Exhaust system for horsepower applications under 450 hp. 5" Rapid Flow Exhaust Systems are recommended for applications running between 450 to 550 horsepower.
Exhaust Rattle	Exhaust Sounds	Either one of the Clamps is not tight or the exhaust is coming in contact with the chasis or body. Adjust the exhaust to ensure that no contact is made.
Exhaust is too loud	Exhaust Sounds	If your exhaust seems too loud, Bully Dog can sell you another muffler which will allow you to double stack mufflers. This extra muffler would take place of one of the straight pipes included with this system. Part # 185026
Exhaust is not loud enough	Exhaust Sounds	If your exhaust is too quiet (and is being used exclusively for off-road use) you can purchase another straight pipe to replace your muffler. Part # 185027

WARRANTY & DISCLAIMER

REMEMBER, THIS IS A PERFORMANCE PRODUCT, USE AT YOUR OWN RISK.

This product is not intended to be used to break the law.

Do not use this product until you have carefully read the following agreement. This agreement sets forth the terms and conditions for the use of this product. The installation of this product indicates that the buyer has read and understands this agreement and accepts the terms and conditions. Never exceed recommended vehicle or tire top speed ratings.

DISCLAIMER OF LIABILITY

Bully Dog Technologies, LLC. Its distributors, jobbers, and dealers (hereafter Seller) shall be in no way responsible for the product's proper use and service. THE BUYER HERBY WAIVES ALL LIABILITY CLAIMS.

The Buyer acknowledges that he is not relying on the Sellers skill or judgment to select or furnish goods suitable for any particular purpose and that there are no liabilities which extend beyond the description on the face hereof, and the Buyers hereby waives all remedies or liabilities expressed or implied, arising by law or otherwise, (including without any obligation of the Seller with respect fitness, merchantability and consequential damages) or whether or not occasioned by the Seller's negligence.

The Seller disclaims any warranty and expressly disclaims any liability for personal injury or damages. The Buyer acknowledges and agrees that the disclaimer of any liability for personal injury is a material term for this agreement and the Buyer agrees to indemnify the Seller and to hold the Seller harmless from any claim related to the item of the equipment purchased. Under no circumstances will the Seller be liable for any damages or expenses by reason of use or sale of any such equipment.

The Seller assumes no liability regarding the improper installation or misapplication of its products. It is the installer's responsibility to check for proper installation and if in doubt contact the manufacturer.

The Buyer is solely responsible for all warranty issues from the manufacturer.

LIMITATION OF WARRANTY

BULLY DOG TECHNOLOGIES, LLC. (Hereafter "Seller") gives Limited Warranty as to description, quality, merchantability, and fitness for any particular purpose, productiveness, or any other matter of Seller's product sold herewith. The Seller shall be in no way responsible for the products proper use and service and the Buyer hereby waives all rights other than those expressly written herein. This warranty shall not be extended, altered or varied except be a written instrument signed by Seller and Buyer.

The Warranty is Limited to one (1) year from the date of sale and limited solely to the parts contained within the products kit. All products that are in question of Warranty must be returned prepaid to the Seller and must be accompanied by a dated proof of purchase receipt. All Warranty claims are subject to approval by BULLY DOG TECHNOLOGIES, LLC.

Under no circumstances will the Seller be liable for any labor charged or travel time incurred in diagnosis for defects, removal, or reinstallation of this product or any other contingent expenses.

Under no circumstances will the Seller be liable for any damage or expenses incurred by reason of the use or sale of any such equipment.

IN THE EVENT THAT THE BUYER DOES NOT AGREE WITH THIS AGREEMENT: THE BUYER MAY PROMPTLY RETURN THIS PRODUCT, IN A NEW AND UNUSED CONDITION, WITH A DATED PROOF OF PURCHASE TO THE PLACE OF PURCHASE WITHIN TEN (10) DAYS FROM DATE OF PURCHASE FOR A FULL REFUND.

THE INSTALLATION OF THIS PRODUCT INDICATES THAT THE BUYER HAS READ AND UNDERSTANDS THIS AGREEMENT AND ACCEPTS ITS TERMS AND CONDITIONS.