

UNPACKING/PACKAGING THE CHAIR FOR SHIPPING

HT-125

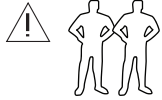

CAUTION! Your massage chair is a precision instrument that can be damaged if dropped. You will need at least two people to complete this procedure, Be sure you have enough people to lift and move the chair, to prevent injury.

SERVICE LEVEL: 2

NOTE: Save all packaging materials - you will need them to package the existing chair properly for shipping back to Human Touch.

List of components for packing (Fig.1):

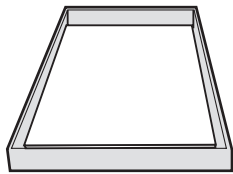

Box base (1)

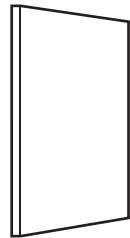

Large foam panel (2)

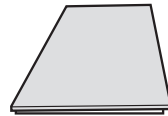

Cardboard panel (1)
(covers the chair)



Cardboard support (1)

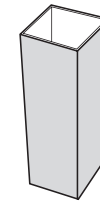

Corner spacer (4)

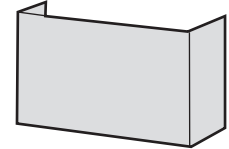

Seat pad spacer (1)

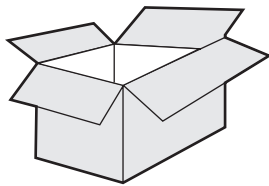

Box sides (1)



Armrest spacer (2)

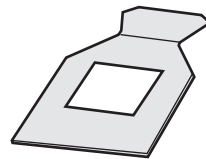

Cardboard panel (1)
(for headrest)



Cardboard/foam panel (1)
(covers the seat)

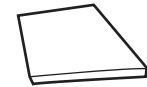

Foam (1)
(top of headrest)



Remote
control box (1)



Foam armrest
protector (2)

*shape differs slightly
between chair models



Wood side panel
protector (2)

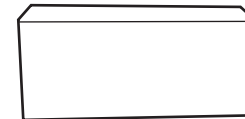

Foam spacer (1) (front
of the foot and calf
massager)

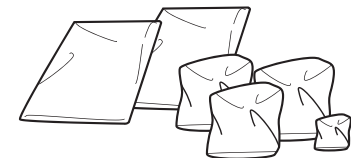

Large (2), medium (3), and
small (1) plastic bag

(Fig.1)

UNPACKING THE CHAIR

1. Cut the shipping bands and remove the box cover.
2. Remove the rectangular cardboard panel that covers the chair.
3. Remove the backrest pad, massage-softening pad and head pillow from on top of the backrest.
4. Remove the seat pad and the rectangular cardboard spacer from near the chair base.
5. Remove the spacers from each corner of the box.
6. Remove the cardboard seat pad spacer from near the chair base.
7. Remove the box sides from the base.
8. Remove the foam armrest spacers from both sides of the backrest.
9. Remove the cardboard panel from the headrest.
10. Gently raise the backrest to an upright position.
11. Remove the cardboard/foam panel from the seat.
12. Remove foam from top of headrest.
13. Remove the remote control box from the left-hand armrest.
14. Remove the foam armrest protectors.
15. Remove the foam spacer from in front of the foot and calf massager.
16. Remove the protective plastic bags that cover the backrest and the foot and calf massager.
17. Using two people, lift the chair gently from the box base.

PACKAGING THE CHAIR FOR SHIPPING

1. Place the large foam panel(s) inside the box base and position the box base such that you have room to move freely on all sides of it.
2. Using two people, lift the chair gently onto the box base.
3. Slip a one of the large plastic bags over the backrest and one of the medium plastic bags over the foot and calf massager.
4. Place the small rectangular foam panel over the headrest, then cover it with the cardboard headrest panel (Fig.1).
Secure the panel to the protective plastic bag using shipping tape.
5. Place a foam armrest protector over each armrest (Fig.2).

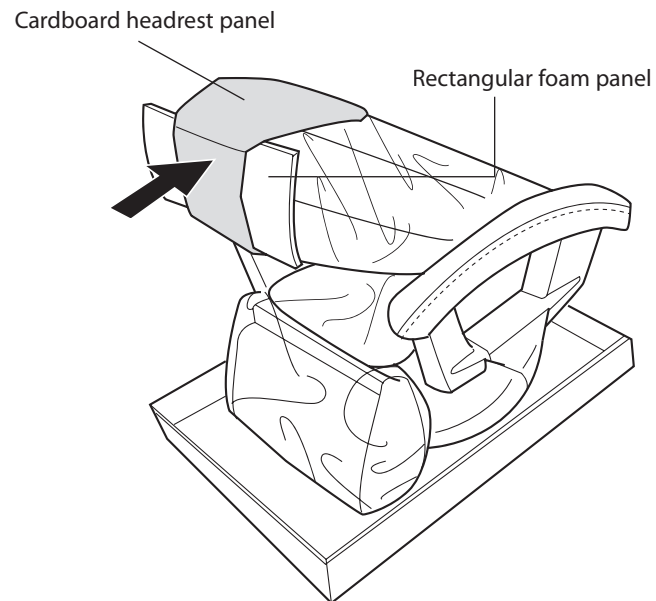

(Fig.1)

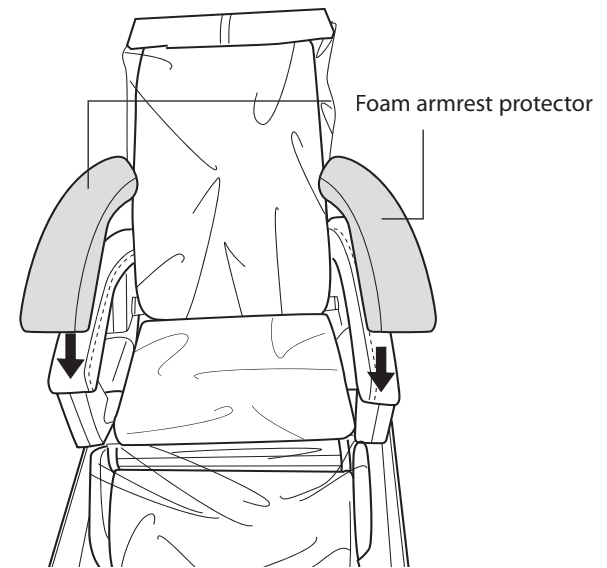

(Fig.2)

6. Place the cardboard/foam panel onto the seat (Fig.3).
7. Press the backrest release lever, located on the lower back of the chair, then gently fold the backrest forward onto the seat (Fig.4).
8. Place a foam armrest spacer between the backrest and each armrest (Fig.5).
9. Place the remote control into the remote control box, and secure on the inside of the armrest, using shipping tape.
10. Place the foam foot and calf massager spacer in front of the foot and calf massager (Fig.7).

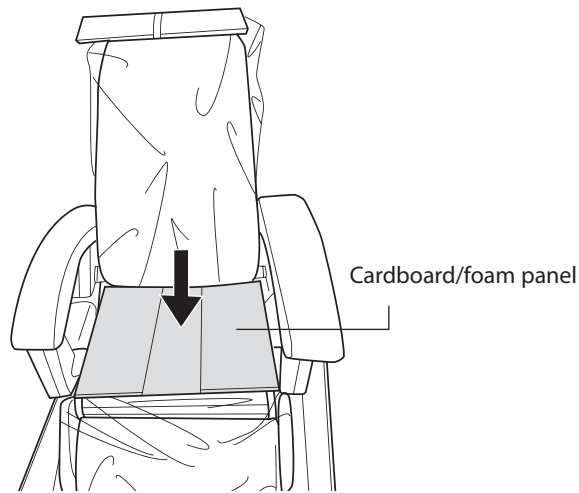

(Fig.3)

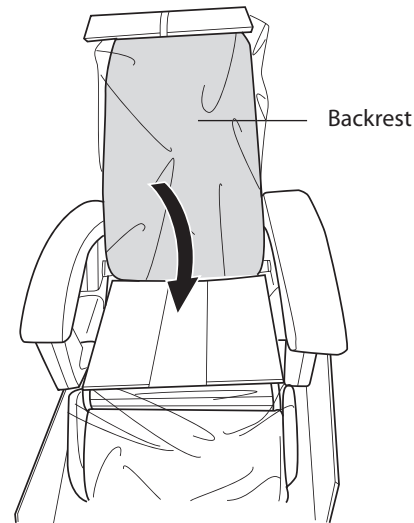

(Fig.4)

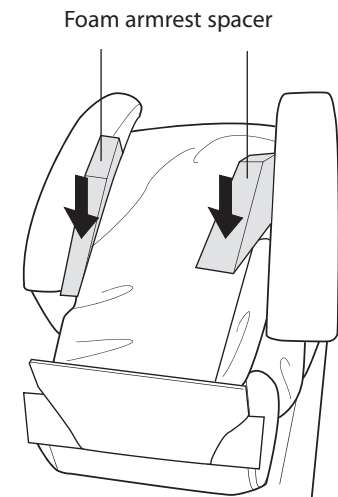

(Fig.5)

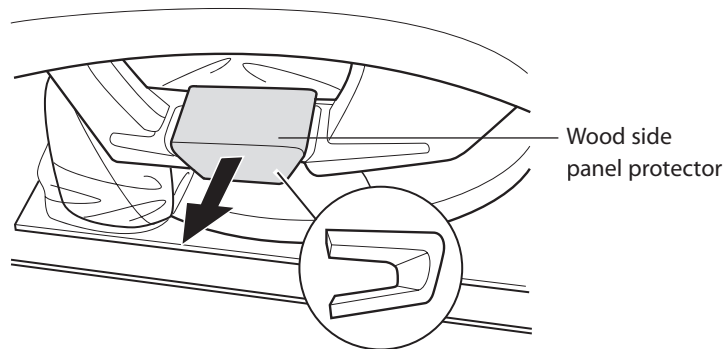

(Fig.6)

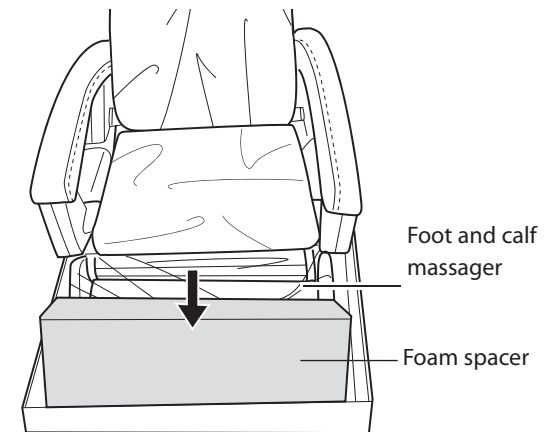

(Fig.7)

11. Install the box sides onto the box base, ensuring that the sides are inside the base (Fig.8).
12. Install the cardboard seat pad spacer near the chair base (Fig.9).
13. Place the seat pad into the space created by the cardboard seat pad spacer (Fig.10).
14. Place the rectangular cardboard support across the chair base (Fig.10).

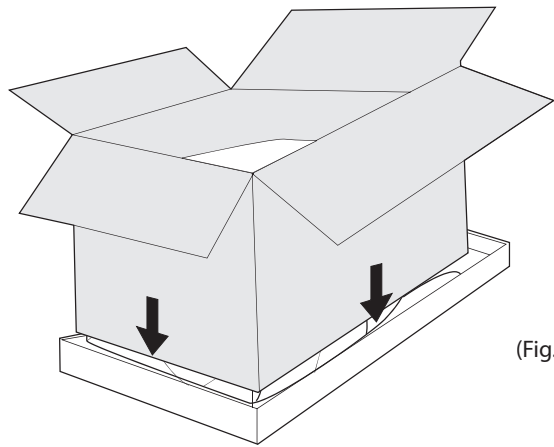

(Fig.8)

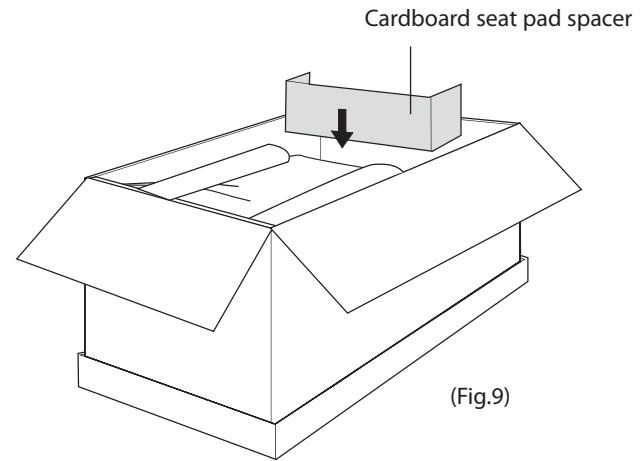

(Fig.9)

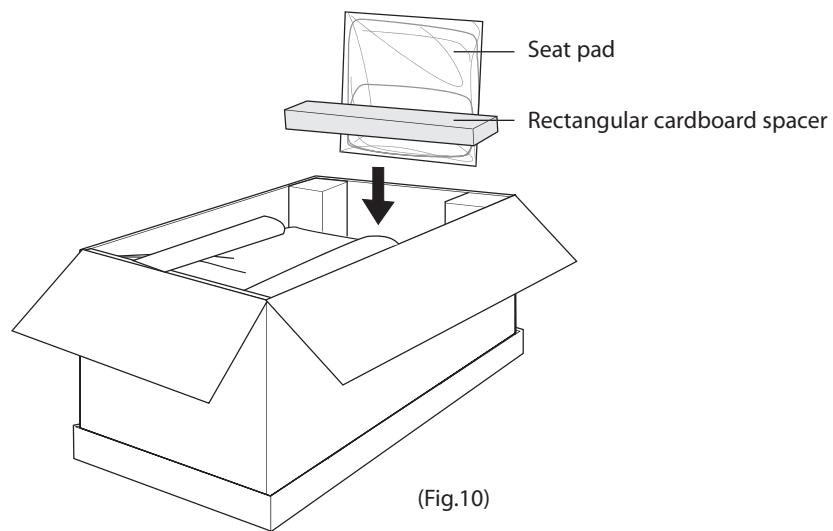

(Fig.10)

15. Install a corner spacer into each corner (Fig.11).
16. Insert the backrest pad into one of the large plastic bags, and the seat pad and head pillow each into one of the medium plastic bags, then place them on top of the backrest (Fig.12).
17. Place the large cardboard panel on top of the backrest (Fig.13).
18. Place the box lid on the box and secure it with shipping bands.

