

Hi DELTA[®]

Sealed Combustion Boilers & Water Heaters

UP TO 85% THERMAL EFFICIENCY



**Versa IC[®]
Control System**

**Models 302C thru 2342C
CSA certified Low Lead Content
Less Than - .25% Lead**



The Hot Water Management Experts

 Proudly assembled in U.S.A



Hi DELTA[®]

Up to **85%** thermal efficiency!

Raypak's Hi Delta

Decades of expertise and technological innovations went into creating the Hi Delta boiler, a product that incorporates features sought after by engineers, installers and end-users alike.

In 1948, Raypak introduced the first straight copper finned-tube boiler designed with reliability and serviceability in mind. The tradition continues with Raypak's Hi Delta model. It's patented burner "security blanket," an ingenious enhancement that provides a perfected air-gas pathway for complete combustion, makes the Hi Delta the most adaptable sealed-combustion boiler on the market today.

While many manufacturers claim simple, convenient heat exchanger removal, servicing the Hi Delta couldn't be more straightforward. Just open the unit from the front and slide it out on built-in runners.

Adding to the Hi Delta's ease of use is the On-board Diagnostic Center. In the event of an operating problem, this key enhancement allows an on-site technician to quickly review the unit's entire fault history, in easy to understand "real English". No cryptic codes to deal with. Our diagnostic center even offers possible solutions to the problem at hand.

The Hi Delta product family covers the full spectrum of both indoor and outdoor applications including space heating, process heating, pool heating and domestic hot water heating. When installed indoors, the Hi Delta's versatility is revealed in smaller vent diameters, direct-venting and the convenience of stacking without an increased footprint.

Raypak's focus on customer satisfaction goes beyond product design. Like all Raypak boilers, every Hi Delta is factory-fire tested, assuring reliable start-up upon installation.

For over 60 years, Raypak professionals have earned their reputation as The Hot Water Management Experts. From system design through installation and start-up, you can count on your local Raypak Representative and the backing of the industry's best sales staff, applications engineers and service department.

Key Features

- Models from 300,000 to 2,340,000 BTUH
- Versa IC[®] Control
- Cascade up to 4 units
- All models indoor/outdoor construction
- Efficiency:
 - 85% Water Heaters- standard
 - 84% Boilers- standard
- Patented burner "security blanket" enhances staged combustion, minimizes installation and start-up issues, and protects burners from metal fatigue
- 105°F minimum inlet water temp
- Copper finned-tube heat exchanger standard; Cupro-nickel optional
- CSA low-lead certified (less than .25%)
- Bronze headers standard on water heaters, optional on boilers
- Sidewall venting ready; No extractor needed for most applications
- Ducted combustion air ready; TruSeal[®] CSA-certified direct-vent available
- Status display and on-board diagnostic center, real english, no codes.
- Less than 20ppm NO_x

Options

- G-20 – Low Gas Pressure operation
CSA-certified for 4" WC supply pressure, natural gas only.
- D-14 – Rear vent option available at time of order
- D-21 – TruSeal direct vent air intake system
- A-6 – Right hand water connection

Visit our website at www.raypak.com to find the Raypak representative in your area.



VERSA IC Boiler Control and On-Board Diagnostic Center

VERSA IC merges safety, ignition, temperature control, multi-unit cascade outdoor reset and freeze protection. Plus system monitoring, diagnostics, and BMS transmission all in one Integrated Control Platform. Easy front access to read, set up and trouble shoot on a 3.5" LCD screen. The entire package is CSA certified, and listed for each individual function.

Inlet and outlet sensors factor installed in boiler. Remote sensor for system included. BMS all point diagnostics transmission port. 0-10VDC set point input standard. Also can drive and monitor external motorized auxiliaries such as extractors and louvers. Additional connections for auxiliary functions, indirect DHW, and dry contact remote alarm relay are provided.

Example Diagnostic Fault Report

Water Flow Sw Fault
Check Boiler Pump, Purge Air, Replace Flow Switch

Diagnostic Information

Control Faults

- Low 24VAC
- Control Setup
- ID Card Fail
- Device Lost
- Device Error
- PIM Error

Ignition Control Faults

- Ignition Lockout
- False Flame
- Ignition Failure
- Low HSI Current
- Blower Speed

Safety Faults

- Sensor Failure - 6
- Vent Block
- Manual Limit
- Auto Limit
- Water Flow
- Delta T Fault
- Low Water
- Low Gas
- High Gas
- Extra 1
- Options

Outdoor Proven

Raypak is no stranger to the outdoor environment. Our touchpad is 100% waterproof and has been proven and perfected on our pool products. No guesswork here, just one tough boiler ready to take on jobs that others have to walk away from.

Building Management System Interface

The Versa IC includes a Modbus communications port as standard for continuous monitoring, trending and troubleshooting. BACnet MS/TP, BACnet IP, N2 Metasys, Modbus TCP and LONworks are available via optional gateways pre-configured from Raypak for seamless integration into a wide range of building management systems.



**BACnet®, Metasys®
 Modbus®**
 gateway module (optional)



LONworks®
 gateway module (optional)



Sidewall Vent
Category III



Vertical Venting
Category I (Type B)



See Cat. 1000.16 for complete SureRack Details

Options

SureRack® Kit

The perfect solution for today's most space challenged equipment rooms. Stacking two Hi Delta 2342 boilers provides over 4.6MMBTU in just over 26 square feet plus clearances. All components (except pumps, flow switches and PRVs) are contained inside the cabinet, so there won't be any standard gas valves or fans hanging off the unit. The units remain fully serviceable even while racked.

- For models 302C thru 2342C
- No Vent Offset Required*
- Small Footprint
- Fits in Low-Ceiling Room

* Lower unit requires D-14 vent tee option.

- Heavy-Duty Construction
- Easy Assembly
- All Hardware Included
- Still Allows for Complete Servicing

Flex Gas® Dual-fuel boilers and water heaters

With its patented, CSA-certified rapid fuel switchover system, the Hi Delta FlexGas is an ideal solution for interruptible-fuel applications (natural/propane gas). (See Cat. #1000.20)

- For models 302C thru 2342C
- Changeover takes less than one minute
- No mechanical components to remove or replace
- Changeover can be accomplished while firing: simply turn the key!
- Factory-installed and tested system
- CSA-Certified



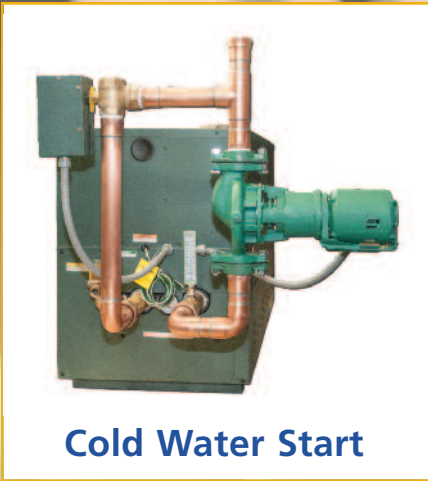

Cold Water Start



Cold Water Run

Cold Water Solution Options

Cold Water Start

It is commonly known that prolonged internal condensation will dramatically shorten the life of standard boilers and water heaters. While Raypak boilers and water heaters can operate without harmful condensation at lower inlet water temperatures than the competition, there are still applications that require reliable protection against harmful condensation caused by frequent, extended, cold water start-ups. Raypak's **Cold Water Start** protection system is only used with closed-loop heating systems and utilizes a proportional three-way valve to bypass water from the boiler outlet to the inlet during start-up, when the system return water temperature is below the minimum acceptable level.

Cold Water Run

For the same reason stated for Cold Water Starts, it is even more important to provide protection against condensation from cold inlet water on systems where the return water temperature to the boiler will always be below the acceptable minimum. Raypak's **Cold Water Run** system can be used on boilers, water heaters or pool heaters, and utilizes a variable-speed pump to inject just the right amount of water from the main system loop into the boiler to maintain the optimum inlet temperature. This approach allows the full capacity of the boiler to be utilized to meet the system load, while at the same time continuously maintaining the optimum inlet water temperature to prevent condensation. (See Cat. #1000.19)

Simple Serviceability

Raypak's easy-to-understand user interface, including on-board diagnostics and LED operating status lights, tells the technician all he needs to know. All service/repair components are readily accessible from the front for maximum installation flexibility.

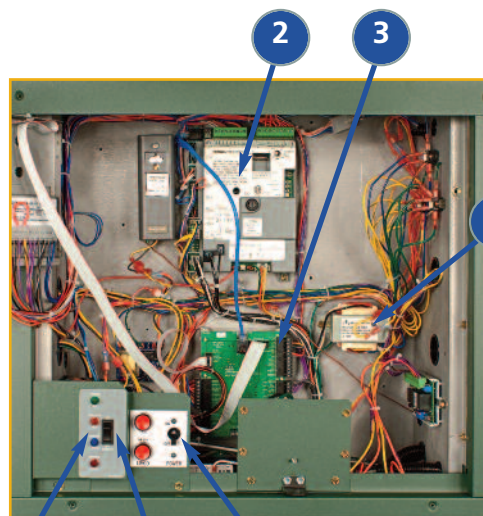
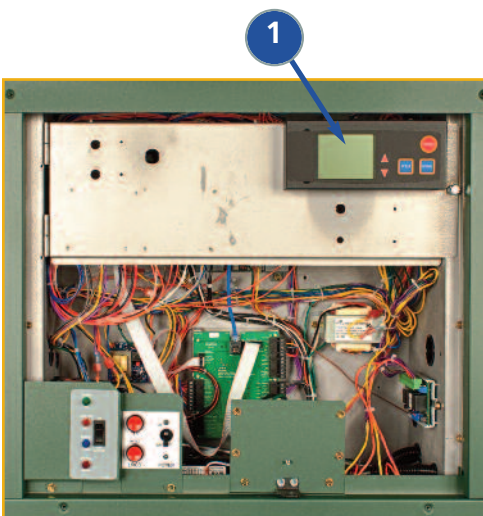

- 1 VERSA IC user interface
- 2 Platform Ignition Module
- 3 Versa Board
- 4 Transformer
- 5 Main power disconnect
- 6 Standby power switch
- 7 Status lights

Ref. Dwg. pg. 5	Hi Delta Model	MBTUH Input*	MBTUH Output*		Dimensions (in.)					Operating Weight (lbs.)	Amps‡
			Type H 84%	Type WH 85%	A Width	B	G NPT	K Flue Ø	W		
1	302C	300	252	255	36	18	3/4	5	14-3/4	380	6
	402C	399	335	339	43	21-1/2	3/4	6	18-1/2	445	6
	502C	500	420	425	50	25	1-1/4	6	22	545	6
	652C	650	546	553	60-1/2	30-1/4	1-1/4	8	27-1/4	590	6
	752C	750	630	638	67-1/2	33-3/4	1-1/4	8	30-3/4	675	6
	902C	900	756	765	78	39	1-1/4	8	36	740	7
2	992C	990	832	842	57-1/8	28-9/16	2	10	16-13/16	900	<12
	1262C	1260	1058	1071	68-1/2	34-1/4	2	12	20-9/16	1010	<12
	1532C	1530	1285	1301	79-7/8	39-15/16	2	12	24-3/8	1225	<12
	1802C	1800	1512	1550	91-1/8	45-9/16	2	14	28-1/8	1350	<12
	2002C ^a	1999	1679	1699	102-1/2	51-1/4	2	14	31-15/16	1450	<12
	2072C	2070	1739	1760	102-1/2	51-1/4	2	14	31-15/16	1450	<12
	2342C	2340	1966	1989	113-7/8	56-15/16	2	16	35-11/16	1520	<12

* Ratings for models 302C-2342C for natural or propane gas and for elevations up to 4,500 ft. above sea level. For higher elevations, consult the factory.

‡ Current draw is for heater only. (Supply breaker must have a delayed trip.)

^a Natural gas only. Not available for propane.

Boiler Side	Indoor		Outdoor	
	Minimum	Service	Minimum	Service
Floor*	0"	0"	0"	0"
Rear	1"	6"	12"	24"
Water side	12"	24"	36"	36"
Other side	1"	24"	36"	36"
Top	1"	6"	Unobstructed	Unobstructed
Front	Open	24"	Open	24"
Vent	2"	2"	N/A	N/A

* Do not install on carpeting.

Hi Delta Model	Water Hardness					
	Soft		Medium		Hard	
	HP	Amps	HP	Amps	HP	Amps
302C	1/8	1.3	1/4	5.7	1/2	7
402C	1/8	1.3	1/4	5.7	1/2	7
502C	1/8	1.3	1/4	5.7	1/2	7
652C	1/8	1.3	1/4	5.7	1/2	7
752C	1/8	1.3	1/2	7	3/4	11
902C	1/2	7	1/2	7	3/4	11
992C	1/2	7	1/2	7	3/4	11
1262C	1/2	7	3/4	11	1	14
1532C	1/2	7	1	14	1	14
1802C	3/4	11	1	14	1-1/2	15
2002C	3/4	11	1-1/2	15	1-1/2	15
2072C	3/4	11	1-1/2	15	1-1/2	15
2342C	1	14	1-1/2	15	1-1/2	15

Note: Current draw (Amps) is for pump only.

DRAWING 1 - MODELS 302C-902C

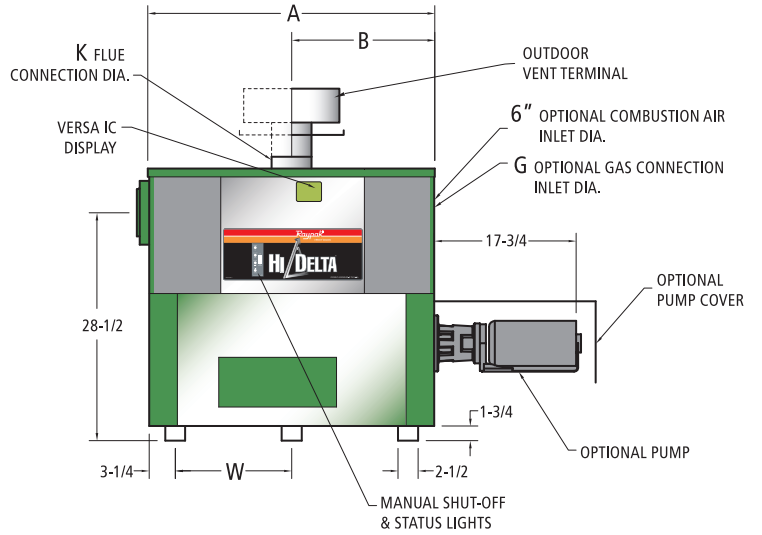
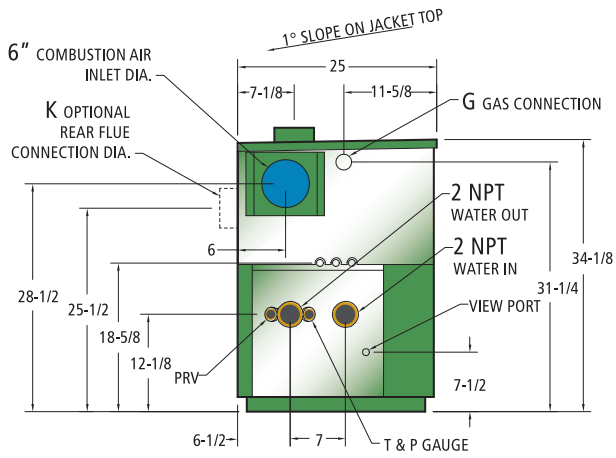

DRAWING 2 - MODELS 992C-2342C

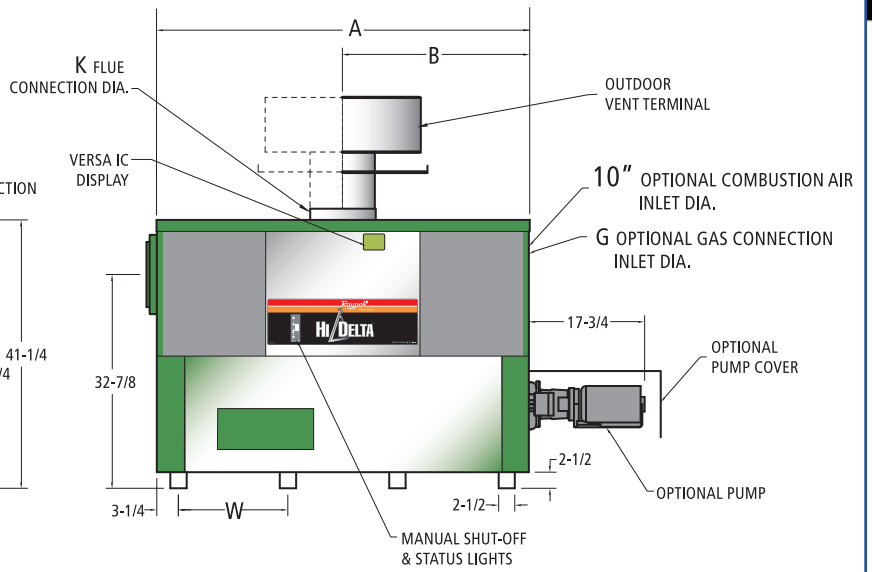
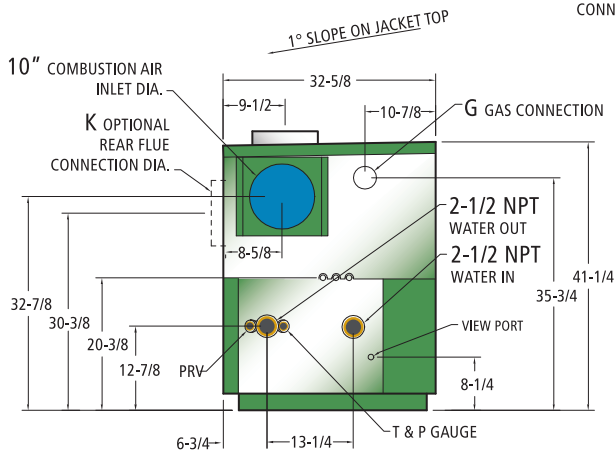

84% EFFICIENCY (TYPE H)	Hi Delta Model	Flow Rates						Pressure Drops							
		Minimum Flow			Maximum Flow			10°F ΔT		20°F ΔT		30°F ΔT		40°F ΔT	
		GPM	ΔP Ft	ΔT °F	GPM	ΔP Ft	ΔT °F	GPM	ΔP Ft	GPM	ΔP Ft	GPM	ΔP Ft	GPM	ΔP Ft
302C	20	0.5	26	90	9.8	6	51	3.2	26	0.8	Less than Minimum Flow				
402C	20	0.5	34	90	10.0	8	68	5.7	34	1.4	23	0.6			
502C	28	1.1	30	90	10.4	9	85	9.3	43	2.4	28	1.1	21	0.6	
652C	37	1.9	30	90	10.8	12	Exceeds Maximum Flow		55	4.2	37	1.9	28	1.1	
752C	43	2.6	30	90	11.3	14			64	5.8	43	2.6	32	1.5	
902C	51	3.9	30	90	11.7	17			77	8.5	51	3.9	38	2.2	
992C	56	2.4	30	132	13.1	13			84	5.4	56	2.4	42	1.4	
1262C	71	4.4	30	132	14.8	16			107	9.8	71	4.4	54	2.5	
1532C	87	7.2	30	132	16.5	20			130	16.1	87	7.2	65	4.1	
1802C	87	8.0	35	132	18.3	23					102	10.9	77	6.2	
2002C	97	10.5	35	132	19.0	26					113	14.2	85	8.1	
2072C	101	11.2	35	132	19.0	27					117	15.1	88	8.7	
2342C	114	16.0	35	132	21.4	30					133	21.6	99	12.3	

85% EFFICIENCY (TYPE WH)	Hi Delta Model	Water Hardness												Minimum Tube Size (MTS)
		Soft				Medium				Hard				
		ΔT °F	GPM	ΔP Ft	SHL*	ΔT °F	GPM	ΔP Ft	SHL*	ΔT °F	GPM	ΔP Ft	SHL*	
302C	13	40	2.0	3.5	10	52	3.3	5.8	6	90	9.8	16.7	2"	
402C	17	40	2.0	3.5	13	52	3.4	5.9	8	90	10.0	16.9	2"	
502C	21	40	2.1	3.7	16	52	3.5	6.1	9	90	10.4	17.3	2"	
652C	28	40	2.2	3.8	20	55	4.1	6.9	12	90	10.8	17.7	2"	
752C	30	42	2.6	4.3	20	63	5.7	9.2	14	90	11.3	18.2	2"	
902C	30	51	3.9	6.3	20	76	8.4	13.5	17	90	11.7	18.6	2"	
992C	28	60	2.7	4.0	20	83	5.2	7.4	13	132	13.1	18.4	2-1/2"	
1262C	30	72	4.4	6.2	20	106	9.6	13.1	16	132	14.8	20.1	2-1/2"	
1532C	30	86	7.1	9.5	20	132	16.5	21.8	20	132	16.5	21.8	2-1/2"	
1802C	30	102	10.9	17.4	25	120	15.1	23.9	23	132	18.3	28.7	2-1/2"	
2002C	30	112	13.9	17.7	26	132	19.0	24.3	26	132	19.0	24.3	2-1/2"	
2072C	30	116	14.8	18.9	27	132	19.0	24.3	27	132	19.0	24.3	2-1/2"	
2342C	30	132	21.4	26.6	30	132	21.4	26.6	30	132	21.4	26.6	2-1/2"	

NOTES: Minimum flow rates in closed systems may be reduced to a flow rate consistent with a 39°F ΔT.
Maximum flow rates are limited by maximum acceptable velocity through the heat exchanger tubes and may be increased by 10% for closed heating systems. Pressure drop would increase 21%.
*SHL = Calculated at 100 feet effective pipe length.



		Recovery Rates (GPH)															
Hi Delta Model	MBTUH Input	Temperature Rise (°F)															
		10	20	30	40	50	60	70	80	90	100	110	120	130	140	150	
84% EFFICIENCY (TYPE H)	302C	300	3055	1527	1018	764	611	509	436	382	339	305	278	255	235	218	204
	402C	399	4063	2031	1354	1016	813	677	580	508	451	406	369	339	313	290	271
	502C	500	5091	2545	1697	1273	1018	848	727	636	566	509	463	424	392	364	339
	652C	650	6618	3309	2206	1655	1324	1103	945	827	735	662	602	552	509	473	441
	752C	750	7636	3818	2545	1909	1527	1273	1091	955	848	764	694	636	587	545	509
	902C	900	9164	4582	3055	2291	1833	1527	1309	1145	1018	916	833	764	705	655	611
	992C	990	10080	5040	3360	2520	2016	1680	1440	1260	1120	1008	916	840	775	720	672
	1262C	1260	12829	6415	4276	3207	2566	2138	1833	1604	1425	1283	1166	1069	987	916	855
	1532C	1530	15578	7789	5193	3895	3116	2596	2225	1947	1731	1558	1416	1298	1198	1113	1039
	1802C	1800	18327	9164	6109	4582	3665	3055	2618	2291	2036	1833	1666	1527	1410	1309	1222
	2002C	1999	20353	10177	6784	5088	4071	3392	2908	2544	2261	2035	1850	1696	1566	1454	1357
	2072C	2070	21076	10538	7025	5269	4215	3513	3011	2635	2342	2108	1916	1756	1621	1505	1405
	2342C	2340	23825	11913	7942	5956	4765	3971	3404	2978	2647	2383	2166	1985	1833	1702	1588

		Recovery Rates (GPH)															
Hi Delta Model	MBTUH Input	Temperature Rise (°F)															
		10	20	30	40	50	60	70	80	90	100	110	120	130	140	150	
85% EFFICIENCY (TYPE WH)	302C	300	3091	1545	1030	773	618	515	442	386	343	309	281	258	238	221	206
	402C	399	4111	2055	1370	1028	822	685	587	514	457	411	374	343	316	294	274
	502C	500	5152	2576	1717	1288	1030	859	736	644	572	515	468	429	396	368	343
	652C	650	6697	3348	2232	1674	1339	1116	957	837	744	670	609	558	515	478	446
	752C	750	7727	3864	2576	1932	1545	1288	1104	966	859	773	702	644	594	552	515
	902C	900	9273	4636	3091	2318	1855	1545	1325	1159	1030	927	843	773	713	662	618
	992C	990	10200	5100	3400	2550	2040	1700	1457	1275	1133	1020	927	850	785	729	680
	1262C	1260	12982	6491	4327	3245	2596	2164	1855	1623	1442	1298	1180	1082	999	927	865
	1532C	1530	15764	7882	5255	3941	3153	2627	2252	1970	1752	1576	1433	1314	1213	1126	1051
	1802C	1800	18545	9273	6182	4636	3709	3091	2649	2318	2061	1855	1686	1545	1427	1325	1236
	2002C	1999	20596	10298	6865	5149	4119	3433	2942	2574	2288	2060	1872	1716	1584	1471	1373
	2072C	2070	21327	10664	7109	5332	4265	3555	3047	2666	2370	2133	1939	1777	1641	1523	1422
	2342C	2340	24109	12055	8036	6027	4822	4018	3444	3014	2679	2411	2192	2009	1855	1722	1607



Boilers (Type H)		Water Heaters (Type WH)	
302C-902C	992C-2342C	302C-902C	992C-2342C

		302C-902C	992C-2342C	302C-902C	992C-2342C	
HEAT EXCHANGER	ASME, National Board Registered, 160 PSI	H Stamp HLW Stamp	● N/A	● N/A	N/A ●	N/A ●
	Heat Exchanger Tubes	Copper Cupro Nickel	● ○	● ○	N/A ●	N/A ●
	Headers	Bronze Cast Iron	○ ●	○ ●	● ○	● ○
	Pressure Relief Valve	30, 45 & 75 PSI Available	○	○	N/A	N/A
		60 PSI	●	●	N/A	N/A
		125 PSI	○	○	●	●
		150 PSI	○	○	○	○
Temperature & Pressure Gauge		●	●	●	●	
Pump – 120V, Single-Phase		○	○	○	○	
OPERATING CONTROLS	120V Power Supply	With 120V/24V Transformer	●	●	●	●
	Pump Time Delay	Single Phase	●	●	●	●
	Diagnostic Display Central	15-Event Memory	●	●	●	●
	Temperature Controller	Versa IC TempTracker Mod+ Hybrid	● ○	● ○	● ○	● ○
SAFETIES	Hot Surface Ignition System	3-try	●	●	●	●
		1-try	○	○	○	○
	High Gas Pressure Switch		○	○	○	○
	Low Gas Pressure Switch		○	●	○	●
	Blocked Vent and Air Pressure Switches		●	●	●	●
	High Limit Switch	Manual Reset, Fixed	●	●	●	●
		Manual Reset, Adjustable	○	○	○	○
Automatic Reset, Adjustable		○	○	○	○	
Low Water Cut-Off, 24V	With manual reset and test button	○	○	○	○	
Flow Switch		●	●	●	●	
GAS TRAIN	Firing Mode	2-Stage (H3, WH3)	●	N/A	●	N/A
		3-Stage (H8, WH8)	N/A	(1)	N/A	(1)
		4-Stage (H9, WH9)	N/A	(2)	N/A	(2)
	4" WC Supply Pressure (G-20)	Natural Gas Only	○	(3)	○	(3)
AIR	TruSeal Direct Vent System		○	○	○	○
	Air Filter, Room Air		●	●	●	●
	Air Filter, Ducted Outside Air		○	○	○	○
OTHER	Efficiency	84% (Category I or III)	●	●	N/A	N/A
		Up to 85% (Category II or IV)	N/A	N/A	●	●
	Combustible Floor Rated		●	●	●	●
	Alarm System		○	○	○	○
	Vent Terminal	Outdoor and Through-the-Wall	○	○	○	○
	Right-Hand Water Connections		○	○	○	○
	CSD-1/GE GAP Control System		(4)	○	(4)	○
	Low NOx Compliance	Less than 20ppm	●	(5)	●	(5)
	Cold Water Start	Cold water protection systems	○	○	○	○
Cold Water Run	Cold water protection systems	○	○	○	○	

Notes:
 1 Standard on 992C.
 2 Standard on Models 1262C-2342C.
 3 Option not available on Model 2002C.

4 Not applicable for Models 302C and 402C; Optional for Models 502C-902C.
 5 Standard on Models 992C-2002C; Models 2072C and 2342C require site testing and have different emissions requirements (Consult factory).

● ● = Standard ○ ○ = Optional

