



**Update Alert:** Firmware updates are posted on the web on a regular basis. We recommend that you check for firmware and/or install guide updates prior to installing this product.

## Installation Guide

The FORD12 firmware for DBALL2 is an all-in-one door lock and override module compatible with specific Ford and Lincoln vehicles.

 This module can only be flashed and configured using XpressVIP at [www.directechs.com](http://www.directechs.com) or using the Directechs Mobile application for smartphones. Refer to the Module Programming section on page 12 for more information.



### Important!

This guide is compatible with the FORD12 firmware version 1.29 and higher.



**Note:** The vehicle pit stop/idle mode feature is not available in this firmware.



The remote start system will not work if:

- The ignition is on.
- The alarm system triggered.
- The hood is open.
- The transmission is not in park (P).
- The vehicle battery voltage is too low.
- The service engine soon light is on.

The following remote start features can be configured via the information display:

- Climate control.
- Heated seats/steering wheel.
- Runtime.
- Remote start enable/disable.



## Index

Vehicle Application Guide.....	02
Installation (Wiring Diagram & Vehicle Wiring Reference Charts).....	03
<b>Programming</b>	
Module Programming.....	12
Module Reset.....	14
Hard Reset.....	14
Feature & Option List.....	15
Feature Programming.....	15
LED Diagnostics & Troubleshooting.....	16
Limited One-Year Consumer Warranty.....	18
Quick Reference Guide.....	19

## Vehicle Application Guide

The table below lists the vehicles and features which are compatible with this product. Refer to the following pages for more information on installation wiring, programming and troubleshooting for these vehicles.

Vehicles	2017	2016	2015	2014	2013	PK-Immobilizer Bypass-Data No Key Req'd	AV-Parking Lights Control	DL-Arm Factory Security	DL-Disarm Factory Security	DL-Door Lock Control	DL-Door Unlock	FOB-Control of aftermarket alarm with OEM remote	RS-Remote Start Ready	RS-SmartStart	RS-Tach / RPM Output	SS-Entry Monitoring ALL Door Pins	SS-Entry Monitoring Hood Pin	SS-Entry Monitoring Trunk/Hatch Pin	SS-Factory Alarm Trigger Monitoring	ST-Brake Status (foot brake)	ST-Ignition Status
<b>Ford</b>																					
Edge (Smart Key)	•	•	•			•	•	•	•	•	•	D	•	D	•	•	•	•	D	•	•
Explorer (Smart Key)	•	•				•	•	•	•	•	•	D	•	D	•	•	•	•	D	•	•
F-150	•	•	•			•	•	•	•	•	•	D	•	D	•	•	•		D	•	•
F-150 (Smart Key)	•	•	•			•	•	•	•	•	•	D	•	D	•	•	•		D	•	•
F-250	•					•	•	•	•	•	•	D	•	D	•	•	•		D	•	•
F-250 (Smart Key)	•					•	•	•	•	•	•	D	•	D	•	•	•		D	•	•
F-350	•					•	•	•	•	•	•	D	•	D	•	•	•		D	•	•
F-350 (Smart Key)	•					•	•	•	•	•	•	D	•	D	•	•	•		D	•	•
F-450	•					•	•	•	•	•	•	D	•	D	•	•	•		D	•	•
Fusion	•	•	•	•		•	•	•	•	•	•	D	•	D	•	•	•	•	D	•	•
Fusion (Smart Key)	•	•	•	•		•	•	•	•	•	•	D	•	D	•	•	•	•	D	•	•
Fusion Hybrid		•	•	•		•	•	•	•	•	•	D	•	D	•	•	•	•	D	•	•
Fusion Hybrid (Smart Key)	•	•	•	•		•	•	•	•	•	•	D	•	D	•	•	•	•	D	•	•
Mustang (Smart Key)	•	•	•			•	•	•	•	•	•	D	•	D	•	•	•	•	D	•	•
<b>Lincoln</b>																					
Continental (Smart Key)	•					•	•	•	•	•	•	D	•	D	•	•	•	•	D	•	•
MKC (Smart Key)	•	•	•			•	•	•	•	•	•	D	•	D	•	•	•	•	D	•	•
MKX (Smart Key)	•	•				•	•	•	•	•	•	D	•	D	•	•	•	•	D	•	•
MKZ (Smart Key)	•	•	•	•	•	•	•	•	•	•	•	D	•	D	•	•	•	•	D	•	•
MKZ Hybrid (Smart Key)	•	•	•	•	•	•	•	•	•	•	•	D	•	D	•	•	•	•	D	•	•

Legend

- PK: Transponder & Immobilizer Override
- AV: Horn & Lights Controls
- DL: OE Door Lock & Alarm Controls
- FOB: Sync CAN Interface w/ FOB Remote
- RS: Remote Start & Engine Controls
- SS: Integrated Security & Monitoring
- ST: Function/Feature Status

- : D2D & Wire-to-Wire (W2W)
- D: Data-to-Data

# Wiring Diagram - with OEM Remote Start and with THFOD2 T-Harness

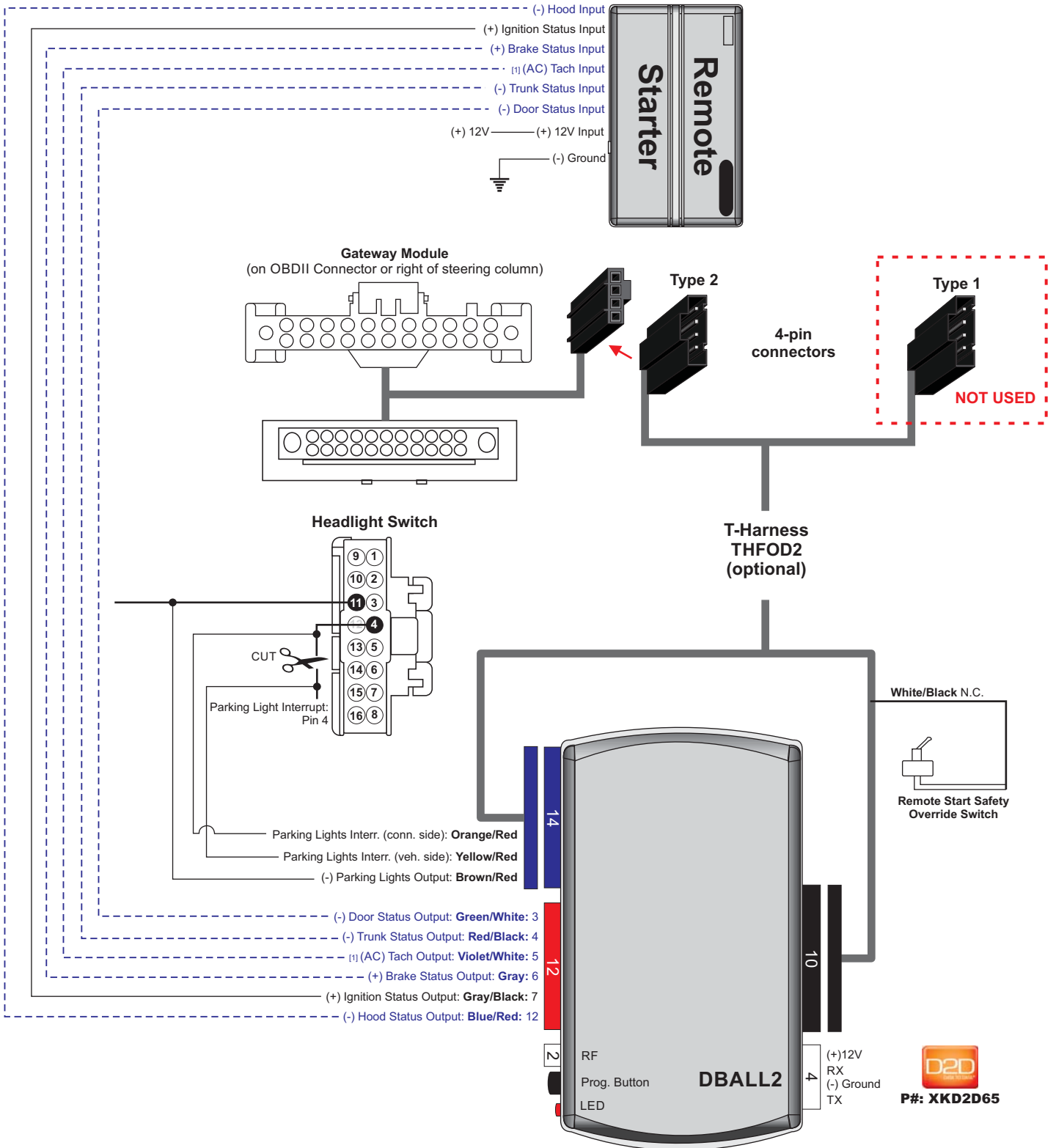

# Wiring Diagram - with OEM Remote Start without T-Harness

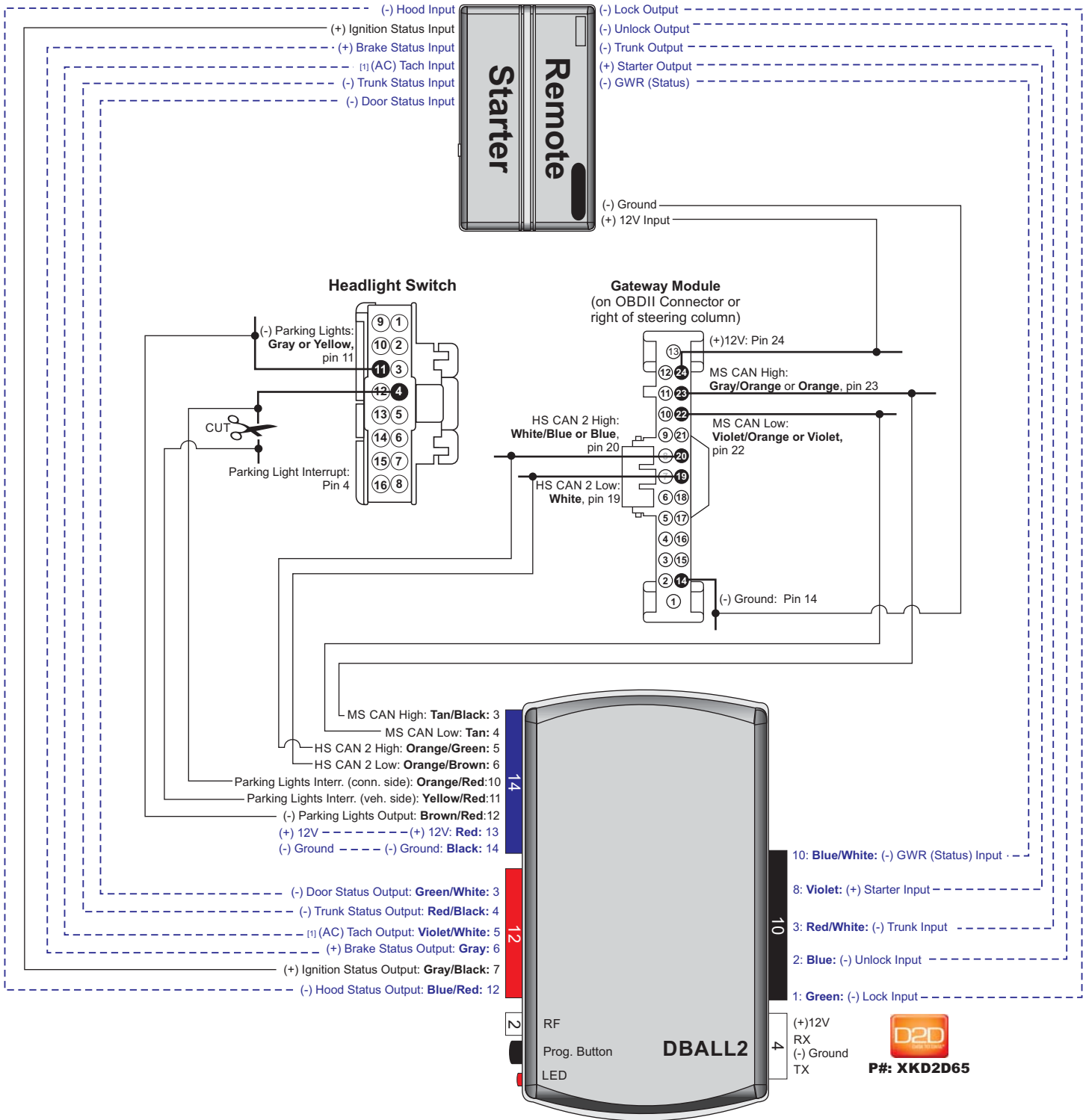

----- Not required in D2D mode.

[1] Tach wire is an optional connection required on some remote starters, which do not support a tach signal in D2D.

Unless specified otherwise, all connectors are displayed from the wire side, with the exception of the OBDII diagnostic connector.

# Wiring Diagram - without OEM Remote Start and with THFOD2 T-Harness

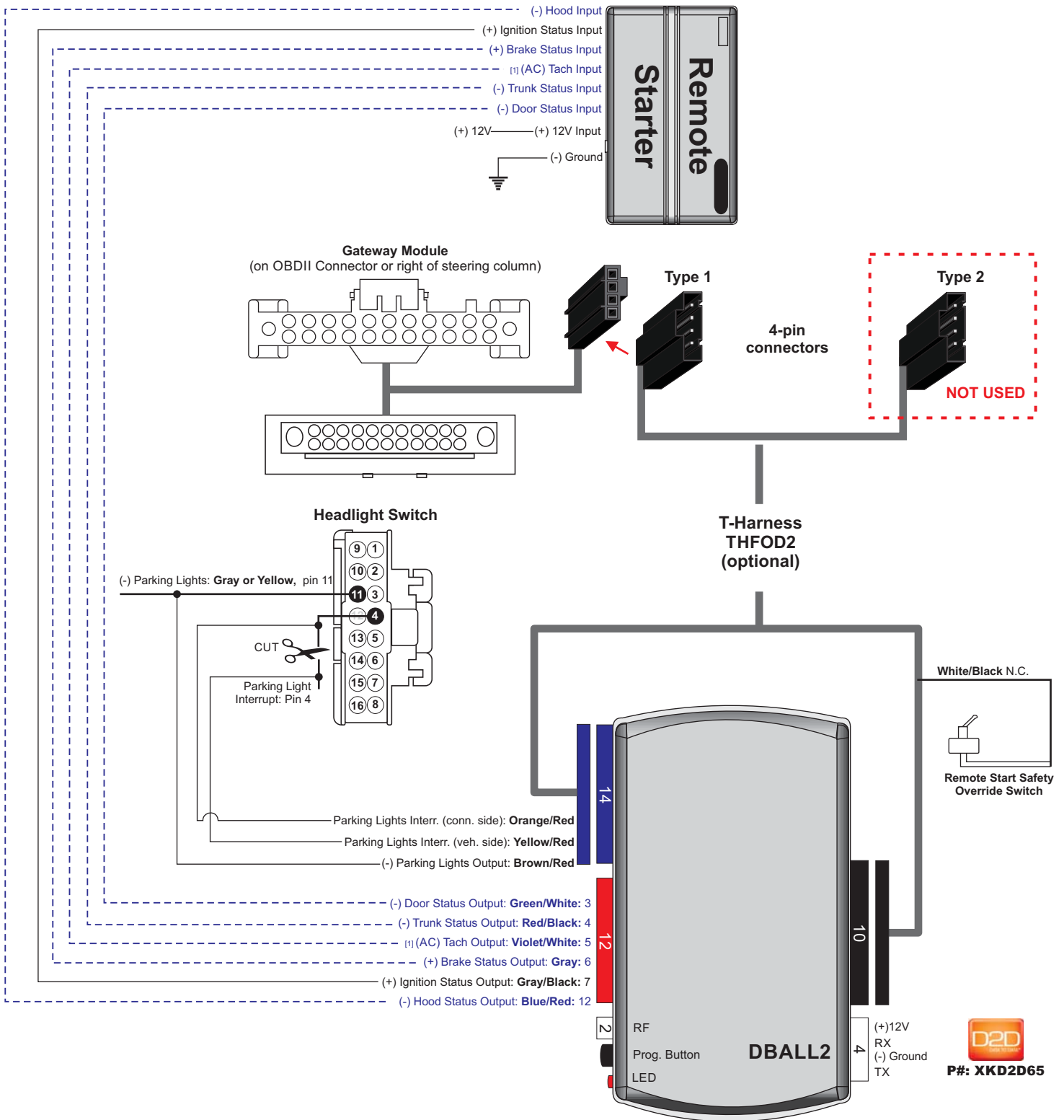

----- Not required in D2D mode.

[1] Tach wire is an optional connection required on some remote starters, which do not support a tach signal in D2D.

Unless specified otherwise, all connectors are displayed from the wire side, with the exception of the OBDII diagnostic connector.

# Wiring Diagram - without OEM Remote Start without T-Harness

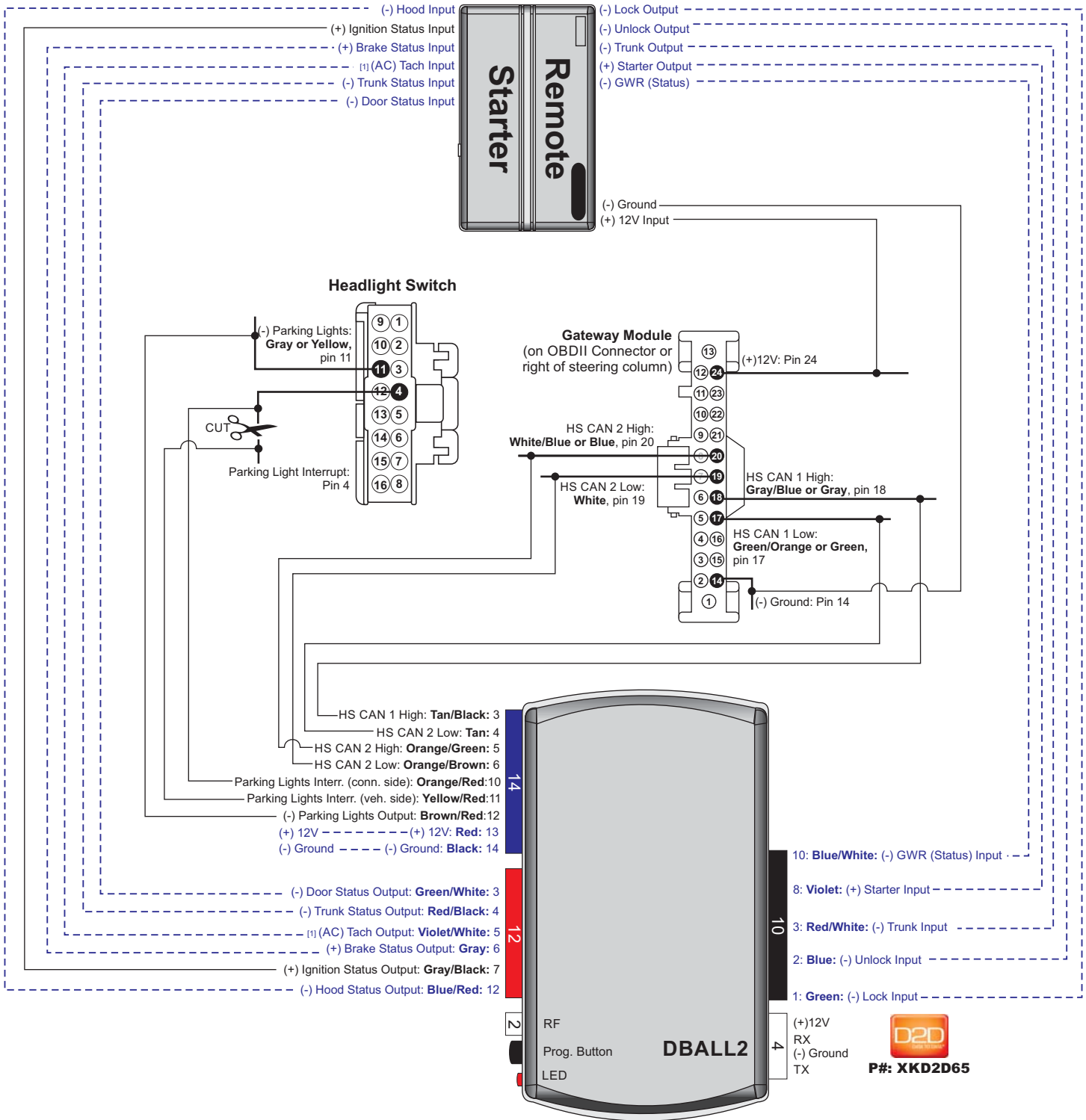

----- Not required in D2D mode.

[1] Tach wire is an optional connection required on some remote starters, which do not support a tach signal in D2D.

Unless specified otherwise, all connectors are displayed from the wire side, with the exception of the OBDII diagnostic connector.

## Vehicle Wiring Reference Chart

Wire Information	Connector Information							
	Function	Color	Pin	Polarity	Location	Color	Pins	Ref.
<b>Ford Edge (Smart Key) 2015-2017</b>								
Parking Lights	Gray	11	(-)	Headlight switch.	Black	16	A	
Parking Lights Interrupt	Black/Blue	4	Cut	Headlight switch.	Black	16	A	
12V	Gray/Red	24	(+)	Gateway module, right of steering column.	Black	24	B	
Ground	Black/Blue	14	(-)	Gateway module, right of steering column.	Black	24	B	
HS CAN 1 High (w/o OEM Remote Start)	Green/Orange	18	Data	Gateway module, right of steering column.	Black	24	B	
HS CAN 1 Low (w/o OEM Remote Start)	Gray/Blue	17	Data	Gateway module, right of steering column.	Black	24	B	
HS CAN 2 High	White/Blue or Blue	20	Data	Gateway module, right of steering column.	Black	24	B	
HS CAN 2 Low	White	19	Data	Gateway module, right of steering column.	Black	24	B	
MS CAN High (w/ OEM Remote Start)	Gray/Orange or Orange	23	Data	Gateway module, right of steering column.	Black	24	B	
MS CAN Low (w/ OEM Remote Start)	Violet/Orange or Violet	22	Data	Gateway module, right of steering column.	Black	24	B	
<b>Ford Explorer (Smart Key) 2016-2017</b>								
Parking Lights	Gray	11	(-)	Headlight switch.	Black	16	A	
Parking Lights Interrupt	Black/White	4	Cut	Headlight switch.	Black	16	A	
12V	Gray/Red	24	(+)	Gateway module on OBDII connector.	Black	24	B	
Ground	Black/White	14	(-)	Gateway module on OBDII connector.	Black	24	B	
HS CAN 1 High (w/o OEM Remote Start)	Green/Orange	18	Data	Gateway module on OBDII connector.	Black	24	B	
HS CAN 1 Low (w/o OEM Remote Start)	Gray/Blue	17	Data	Gateway module on OBDII connector.	Black	24	B	
HS CAN 2 High	White/Blue or Blue	20	Data	Gateway module on OBDII connector.	Black	24	B	
HS CAN 2 Low	White	19	Data	Gateway module on OBDII connector.	Black	24	B	
MS CAN High (w/ OEM Remote Start)	Gray/Orange	23	Data	Gateway module on OBDII connector.	Black	24	B	
MS CAN Low (w/ OEM Remote Start)	Violet/Orange	22	Data	Gateway module on OBDII connector.	Black	24	B	
<b>Ford F-150 (Key) 2015-2017</b>								
Parking Lights	Gray	11	(-)	Headlight switch.	Black	16	A	
Parking Lights Interrupt	Black/Violet	4	Cut	Headlight switch.	Black	16	A	
12V	Green/Red	24	(+)	Gateway module on OBDII connector.	Black	24	B	
Ground	Black/Violet	14	(-)	Gateway module on OBDII connector.	Black	24	B	
HS CAN 1 High (w/o OEM Remote Start)	Green/Orange	18	Data	Gateway module on OBDII connector.	Black	24	B	
HS CAN 1 Low (w/o OEM Remote Start)	Gray/Blue	17	Data	Gateway module on OBDII connector.	Black	24	B	
HS CAN 2 High	White/Blue or Blue	20	Data	Gateway module on OBDII connector.	Black	24	B	
HS CAN 2 Low	White	19	Data	Gateway module on OBDII connector.	Black	24	B	
MS CAN High (w/ OEM Remote Start)	Gray/Orange	23	Data	Gateway module on OBDII connector.	Black	24	B	
MS CAN Low (w/ OEM Remote Start)	Violet/Orange	22	Data	Gateway module on OBDII connector.	Black	24	B	
<b>Ford F-150 (Smart Key) 2015-2017</b>								
Parking Lights	Gray	11	(-)	Headlight switch.	Black	16	A	
Parking Lights Interrupt	Black/Violet	4	Cut	Headlight switch.	Black	16	A	
12V	Green/Red	24	(+)	Gateway module on OBDII connector.	Black	24	B	
Ground	Black/Violet	14	(-)	Gateway module on OBDII connector.	Black	24	B	
HS CAN 1 High (w/o OEM Remote Start)	Green/Orange	18	Data	Gateway module on OBDII connector.	Black	24	B	
HS CAN 1 Low (w/o OEM Remote Start)	Gray/Blue	17	Data	Gateway module on OBDII connector.	Black	24	B	
HS CAN 2 High	White/Blue or Blue	20	Data	Gateway module on OBDII connector.	Black	24	B	
HS CAN 2 Low	White	19	Data	Gateway module on OBDII connector.	Black	24	B	
MS CAN High (w/ OEM Remote Start)	Gray/Orange	23	Data	Gateway module on OBDII connector.	Black	24	B	
MS CAN Low (w/ OEM Remote Start)	Violet/Orange	22	Data	Gateway module on OBDII connector.	Black	24	B	

## Vehicle Wiring Reference Chart

Wire Information	Connector Information						
	Function	Color	Pin	Polarity	Location	Color	Pins
<b>Ford F-250 (Key) 2017</b>							
Parking Lights	Gray	11	(-)	Headlight switch.	Black	16	A
Parking Lights Interrupt	Black/Violet	4	Cut	Headlight switch.	Black	16	A
12V	Gray/Red	24	(+)	Gateway module on OBDII connector.	Black	24	B
Ground	Black/Violet	14	(-)	Gateway module on OBDII connector.	Black	24	B
HS CAN 1 High (w/o OEM Remote Start)	Green/Orange	18	Data	Gateway module on OBDII connector.	Black	24	B
HS CAN 1 Low (w/o OEM Remote Start)	Gray/Blue	17	Data	Gateway module on OBDII connector.	Black	24	B
HS CAN 2 High	White/Blue or Blue	20	Data	Gateway module on OBDII connector.	Black	24	B
HS CAN 2 Low	White	19	Data	Gateway module on OBDII connector.	Black	24	B
MS CAN High (w/ OEM Remote Start)	Gray/Orange	23	Data	Gateway module on OBDII connector.	Black	24	B
MS CAN Low (w/ OEM Remote Start)	Violet/Orange	22	Data	Gateway module on OBDII connector.	Black	24	B
<b>Ford F-250 (Smart Key) 2017</b>							
Parking Lights	Gray	11	(-)	Headlight switch.	Black	16	A
Parking Lights Interrupt	Black/Violet	4	Cut	Headlight switch.	Black	16	A
12V	Gray/Red	24	(+)	Gateway module on OBDII connector.	Black	24	B
Ground	Black/Violet	14	(-)	Gateway module on OBDII connector.	Black	24	B
HS CAN 1 High (w/o OEM Remote Start)	Green/Orange	18	Data	Gateway module on OBDII connector.	Black	24	B
HS CAN 1 Low (w/o OEM Remote Start)	Gray/Blue	17	Data	Gateway module on OBDII connector.	Black	24	B
HS CAN 2 High	White/Blue or Blue	20	Data	Gateway module on OBDII connector.	Black	24	B
HS CAN 2 Low	White	19	Data	Gateway module on OBDII connector.	Black	24	B
MS CAN High (w/ OEM Remote Start)	Gray/Orange	23	Data	Gateway module on OBDII connector.	Black	24	B
MS CAN Low (w/ OEM Remote Start)	Violet/Orange	22	Data	Gateway module on OBDII connector.	Black	24	B
<b>Ford F-350 (Key) 2017</b>							
Parking Lights	Gray	11	(-)	Headlight switch.	Black	16	A
Parking Lights Interrupt	Black/Violet	4	Cut	Headlight switch.	Black	16	A
12V	White/Red	24	(+)	Gateway module on OBDII connector.	Black	24	B
Ground	Black/Violet	14	(-)	Gateway module on OBDII connector.	Black	24	B
HS CAN 1 High (w/o OEM Remote Start)	Green/Orange	18	Data	Gateway module on OBDII connector.	Black	24	B
HS CAN 1 Low (w/o OEM Remote Start)	Gray/Blue	17	Data	Gateway module on OBDII connector.	Black	24	B
HS CAN 2 High	White/Blue or Blue	20	Data	Gateway module on OBDII connector.	Black	24	B
HS CAN 2 Low	White	19	Data	Gateway module on OBDII connector.	Black	24	B
MS CAN High (w/ OEM Remote Start)	Gray/Orange	23	Data	Gateway module on OBDII connector.	Black	24	B
MS CAN Low (w/ OEM Remote Start)	Violet/Orange	22	Data	Gateway module on OBDII connector.	Black	24	B
<b>Ford F-350 (Smart Key) 2017</b>							
Parking Lights	Gray	11	(-)	Headlight switch.	Black	16	A
Parking Lights Interrupt	Black/Violet	4	Cut	Headlight switch.	Black	16	A
12V	White/Red	24	(+)	Gateway module on OBDII connector.	Black	24	B
Ground	Black/Violet	14	(-)	Gateway module on OBDII connector.	Black	24	B
HS CAN 1 High (w/o OEM Remote Start)	Green/Orange	18	Data	Gateway module on OBDII connector.	Black	24	B
HS CAN 1 Low (w/o OEM Remote Start)	Gray/Blue	17	Data	Gateway module on OBDII connector.	Black	24	B
HS CAN 2 High	White/Blue or Blue	20	Data	Gateway module on OBDII connector.	Black	24	B
HS CAN 2 Low	White	19	Data	Gateway module on OBDII connector.	Black	24	B
MS CAN High (w/ OEM Remote Start)	Gray/Orange	23	Data	Gateway module on OBDII connector.	Black	24	B
MS CAN Low (w/ OEM Remote Start)	Violet/Orange	22	Data	Gateway module on OBDII connector.	Black	24	B



## Vehicle Wiring Reference Chart

Wire Information	Connector Information							
	Function	Color	Pin	Polarity	Location	Color	Pins	Ref.
<b>Ford F-450 (Key) 2017</b>								
Parking Lights	Gray	11	(-)	Headlight switch.	Black	16	A	
Parking Lights Interrupt	Black/Violet	4	Cut	Headlight switch.	Black	16	A	
12V	White/Red	24	(+)	Gateway module on OBDII connector.	Black	24	B	
Ground	Black/Violet	14	(-)	Gateway module on OBDII connector.	Black	24	B	
HS CAN 1 High (w/o OEM Remote Start)	Green/Orange	18	Data	Gateway module on OBDII connector.	Black	24	B	
HS CAN 1 Low (w/o OEM Remote Start)	Gray/Blue	17	Data	Gateway module on OBDII connector.	Black	24	B	
HS CAN 2 High	White/Blue or Blue	20	Data	Gateway module on OBDII connector.	Black	24	B	
HS CAN 2 Low	White	19	Data	Gateway module on OBDII connector.	Black	24	B	
MS CAN High (w/ OEM Remote Start)	Gray/Orange	23	Data	Gateway module on OBDII connector.	Black	24	B	
MS CAN Low (w/ OEM Remote Start)	Violet/Orange	22	Data	Gateway module on OBDII connector.	Black	24	B	
<b>Ford Fusion (Key) 2014-2017</b>								
Parking Lights	Gray or Yellow	11	(-)	Headlight switch.	Black	16	A	
Parking Lights Interrupt	Black/Blue	4	Cut	Headlight switch.	Black	16	A	
12V	Gray/Red	24	(+)	Gateway module on OBDII connector.	Black	24	B	
Ground	Black/Blue	14	(-)	Gateway module on OBDII connector.	Black	24	B	
HS CAN 1 High (w/o OEM Remote Start)	Green	18	Data	Gateway module on OBDII connector.	Black	24	B	
HS CAN 1 Low (w/o OEM Remote Start)	Gray	17	Data	Gateway module on OBDII connector.	Black	24	B	
HS CAN 2 High	White/Blue or Blue	20	Data	Gateway module on OBDII connector.	Black	24	B	
HS CAN 2 Low	White	19	Data	Gateway module on OBDII connector.	Black	24	B	
MS CAN High (w/ OEM Remote Start)	Gray/Orange	23	Data	Gateway module on OBDII connector.	Black	24	B	
MS CAN Low (w/ OEM Remote Start)	Violet/Orange	22	Data	Gateway module on OBDII connector.	Black	24	B	
<b>Ford Fusion (Smart Key) 2014-2017</b>								
Parking Lights	Gray or Yellow	11	(-)	Headlight switch.	Black	16	A	
Parking Lights Interrupt	Black/Blue	4	Cut	Headlight switch.	Black	16	A	
12V	Gray/Red	24	(+)	Gateway module on OBDII connector.	Black	24	B	
Ground	Black/Blue	14	(-)	Gateway module on OBDII connector.	Black	24	B	
HS CAN 1 High (w/o OEM Remote Start)	Green	18	Data	Gateway module on OBDII connector.	Black	24	B	
HS CAN 1 Low (w/o OEM Remote Start)	Gray	17	Data	Gateway module on OBDII connector.	Black	24	B	
HS CAN 2 High	White/Blue or Blue	20	Data	Gateway module on OBDII connector.	Black	24	B	
HS CAN 2 Low	White	19	Data	Gateway module on OBDII connector.	Black	24	B	
MS CAN High (w/ OEM Remote Start)	Gray/Orange	23	Data	Gateway module on OBDII connector.	Black	24	B	
MS CAN Low (w/ OEM Remote Start)	Violet/Orange	22	Data	Gateway module on OBDII connector.	Black	24	B	
<b>Ford Fusion Hybrid (Key) 2014-2016</b>								
Parking Lights	Gray or Yellow	11	(-)	Headlight switch.	Black	16	A	
Parking Lights Interrupt	Black/Blue	4	Cut	Headlight switch.	Black	16	A	
12V	Gray/Red	24	(+)	Gateway module on OBDII connector.	Black	24	B	
Ground	Black/Blue	14	(-)	Gateway module on OBDII connector.	Black	24	B	
HS CAN 1 High (w/o OEM Remote Start)	Green	18	Data	Gateway module on OBDII connector.	Black	24	B	
HS CAN 1 Low (w/o OEM Remote Start)	Gray	17	Data	Gateway module on OBDII connector.	Black	24	B	
HS CAN 2 High	White/Blue or Blue	20	Data	Gateway module on OBDII connector.	Black	24	B	
HS CAN 2 Low	White	19	Data	Gateway module on OBDII connector.	Black	24	B	
MS CAN High (w/ OEM Remote Start)	Gray/Orange	23	Data	Gateway module on OBDII connector.	Black	24	B	
MS CAN Low (w/ OEM Remote Start)	Violet/Orange	22	Data	Gateway module on OBDII connector.	Black	24	B	

## Vehicle Wiring Reference Chart

Wire Information	Connector Information							
	Function	Color	Pin	Polarity	Location	Color	Pins	Ref.
<b>Ford Fusion Hybrid (Smart Key) 2014-2017</b>								
Parking Lights	Gray or Yellow	11	(-)	Headlight switch.	Black	16	A	
Parking Lights Interrupt	Black/Blue	4	Cut	Headlight switch.	Black	16	A	
12V	Gray/Red	24	(+)	Gateway module on OBDII connector.	Black	24	B	
Ground	Black/Blue	14	(-)	Gateway module on OBDII connector.	Black	24	B	
HS CAN 1 High (w/o OEM Remote Start)	Green	18	Data	Gateway module on OBDII connector.	Black	24	B	
HS CAN 1 Low (w/o OEM Remote Start)	Gray	17	Data	Gateway module on OBDII connector.	Black	24	B	
HS CAN 2 High	White/Blue or Blue	20	Data	Gateway module on OBDII connector.	Black	24	B	
HS CAN 2 Low	White	19	Data	Gateway module on OBDII connector.	Black	24	B	
MS CAN High (w/ OEM Remote Start)	Gray/Orange	23	Data	Gateway module on OBDII connector.	Black	24	B	
MS CAN Low (w/ OEM Remote Start)	Violet/Orange	22	Data	Gateway module on OBDII connector.	Black	24	B	
<b>Ford Mustang (Smart Key) 2015-2017</b>								
Parking Lights	Gray	11	(-)	Headlight switch.	Black	16	A	
Parking Lights Interrupt	Black/Blue	4	Cut	Headlight switch.	Black	16	A	
12V	Gray/Red	24	(+)	Gateway module on OBDII connector.	Black	24	B	
Ground	Black/Blue	14	(-)	Gateway module on OBDII connector.	Black	24	B	
HS CAN 1 High (w/o OEM Remote Start)	Lt. Green	18	Data	Gateway module on OBDII connector.	Black	24	B	
HS CAN 1 Low (w/o OEM Remote Start)	White	17	Data	Gateway module on OBDII connector.	Black	24	B	
HS CAN 2 High	Blue	20	Data	Gateway module on OBDII connector.	Black	24	B	
HS CAN 2 Low	White	19	Data	Gateway module on OBDII connector.	Black	24	B	
MS CAN High (w/ OEM Remote Start)	Gray	23	Data	Gateway module on OBDII connector.	Black	24	B	
MS CAN Low (w/ OEM Remote Start)	Violet	22	Data	Gateway module on OBDII connector.	Black	24	B	
<b>Lincoln Continental (Smart Key) 2017</b>								
Parking Lights	Gray	11	(-)	Headlight switch.	Black	16	A	
Parking Lights Interrupt	Black/Blue	4	Cut	Headlight switch.	Black	16	A	
12V	Gray/Red	24	(+)	Gateway module on OBDII connector.	Black	24	B	
Ground	Black/Blue	14	(-)	Gateway module on OBDII connector.	Black	24	B	
HS CAN 1 High (w/o OEM Remote Start)	Green/Orange	18	Data	Gateway module on OBDII connector.	Black	24	B	
HS CAN 1 Low (w/o OEM Remote Start)	Gray/Blue	17	Data	Gateway module on OBDII connector.	Black	24	B	
HS CAN 2 High	White/Blue or Blue	20	Data	Gateway module on OBDII connector.	Black	24	B	
HS CAN 2 Low	White	19	Data	Gateway module on OBDII connector.	Black	24	B	
MS CAN High (w/ OEM Remote Start)	Gray/Orange	23	Data	Gateway module on OBDII connector.	Black	24	B	
MS CAN Low (w/ OEM Remote Start)	Violet/Orange	22	Data	Gateway module on OBDII connector.	Black	24	B	
<b>Lincoln MKC (Smart Key) 2015-2017</b>								
Parking Lights	Gray	11	(-)	Headlight switch.	Black	16	A	
Parking Lights Interrupt	Black/Violet	4	Cut	Headlight switch.	Black	16	A	
12V	Gray/Red	24	(+)	Gateway module on OBDII connector.	Black	24	B	
Ground	Black	14	(-)	Gateway module on OBDII connector.	Black	24	B	
HS CAN 1 High (w/o OEM Remote Start)	Green/Orange	18	Data	Gateway module on OBDII connector.	Black	24	B	
HS CAN 1 Low (w/o OEM Remote Start)	Gray/Blue	17	Data	Gateway module on OBDII connector.	Black	24	B	
HS CAN 2 High	White/Blue or Blue	20	Data	Gateway module on OBDII connector.	Black	24	B	
HS CAN 2 Low	White	19	Data	Gateway module on OBDII connector.	Black	24	B	
MS CAN High (w/ OEM Remote Start)	Gray/Orange	23	Data	Gateway module on OBDII connector.	Black	24	B	
MS CAN Low (w/ OEM Remote Start)	Violet/Orange	22	Data	Gateway module on OBDII connector.	Black	24	B	

## Vehicle Wiring Reference Chart

Wire Information	Connector Information							
	Function	Color	Pin	Polarity	Location	Color	Pins	Ref.
<b>Lincoln MKX (Smart Key) 2016-2017</b>								
Parking Lights	Gray	11	(-)	Headlight switch.	Black	16	A	
Parking Lights Interrupt	Black/Blue	4	Cut	Headlight switch.	Black	16	A	
12V	Gray/Red	24	(+)	Gateway module, right of steering column.	Black	24	B	
Ground	Black/Blue	14	(-)	Gateway module, right of steering column.	Black	24	B	
HS CAN 1 High (w/o OEM Remote Start)	Green/Orange	18	Data	Gateway module, right of steering column.	Black	24	B	
HS CAN 1 Low (w/o OEM Remote Start)	Gray/Blue	17	Data	Gateway module, right of steering column.	Black	24	B	
HS CAN 2 High	White/Blue or Blue	20	Data	Gateway module, right of steering column.	Black	24	B	
HS CAN 2 Low	White	19	Data	Gateway module, right of steering column.	Black	24	B	
MS CAN High (w/ OEM Remote Start)	Gray/Orange	23	Data	Gateway module, right of steering column.	Black	24	B	
MS CAN Low (w/ OEM Remote Start)	Violet/Orange	22	Data	Gateway module, right of steering column.	Black	24	B	
<b>Lincoln MKZ (Smart Key) 2013-2017</b>								
Parking Lights	Yellow	11	(-)	Headlight switch.	Black	16	A	
Parking Lights Interrupt	Black/Blue	4	Cut	Headlight switch.	Black	16	A	
12V	Gray/Red	24	(+)	Gateway module on OBDII connector.	Black	24	B	
Ground	Black/Blue	14	(-)	Gateway module on OBDII connector.	Black	24	B	
HS CAN 1 High (w/o OEM Remote Start)	Green	18	Data	Gateway module on OBDII connector.	Black	24	B	
HS CAN 1 Low (w/o OEM Remote Start)	Gray	17	Data	Gateway module on OBDII connector.	Black	24	B	
HS CAN 2 High	White/Blue or Blue	20	Data	Gateway module on OBDII connector.	Black	24	B	
HS CAN 2 Low	White	19	Data	Gateway module on OBDII connector.	Black	24	B	
MS CAN High (w/ OEM Remote Start)	Gray/Orange	23	Data	Gateway module on OBDII connector.	Black	24	B	
MS CAN Low (w/ OEM Remote Start)	Violet/Orange	22	Data	Gateway module on OBDII connector.	Black	24	B	
<b>Lincoln MKZ Hybrid (Smart Key) 2013-2017</b>								
Parking Lights	Yellow	11	(-)	Headlight switch.	Black	16	A	
Parking Lights Interrupt	Black/Blue	4	Cut	Headlight switch.	Black	16	A	
12V	Gray/Red	24	(+)	Gateway module on OBDII connector.	Black	24	B	
Ground	Black/Blue	14	(-)	Gateway module on OBDII connector.	Black	24	B	
HS CAN 1 High (w/o OEM Remote Start)	Green	18	Data	Gateway module on OBDII connector.	Black	24	B	
HS CAN 1 Low (w/o OEM Remote Start)	Gray	17	Data	Gateway module on OBDII connector.	Black	24	B	
HS CAN 2 High	White/Blue or Blue	20	Data	Gateway module on OBDII connector.	Black	24	B	
HS CAN 2 Low	White	19	Data	Gateway module on OBDII connector.	Black	24	B	
MS CAN High (w/ OEM Remote Start)	Gray/Orange	23	Data	Gateway module on OBDII connector.	Black	24	B	
MS CAN Low (w/ OEM Remote Start)	Violet/Orange	22	Data	Gateway module on OBDII connector.	Black	24	B	

## Module Programming

 Refer to the LED Diagnostics section on pages 16-17 for more information and for troubleshooting purposes.

### Important

Make all the required connections to the vehicle, as described in the wiring diagram(s) found in this guide, and double check to ensure everything is correct prior to moving onto the next step.

 **Warning!** To take advantage of advanced features, you must use XpressVIP 4.5 (and higher) or the Directechs Mobile app.

#### Flashing a module using your computer:

1. Connect the interface module to your computer using the XKLoader2.
2. Go to [www.directechs.com](http://www.directechs.com) using Internet Explorer, and select the **Flash Module** button.
3. Follow the instructions to select your vehicle, installation type, and configure your options.
4. Once you have configured the firmware options, click on the **FLASH** button.

#### Flashing a module using your smartphone or tablet

1. Connect the interface module to your XKLoader3.
2. Launch the Directechs Mobile app on your smartphone or tablet.
3. Select **FLASH YOUR MODULE** and follow the on screen instructions.

When the flashing operation is successful, you can proceed with the programming instructions below.

#### D2D Installation

If required for your installation, connect the 10-pin, 12-pin and 14-pin harnesses to the module, then connect the 4-pin D2D harness.

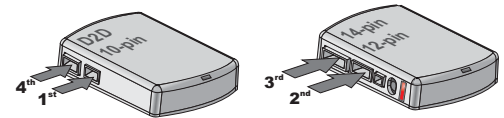

### OR

#### W2W Installation

If required for your installation, connect the 10-pin and 12-pin harnesses to the module, then connect the 14-pin harness to the module.

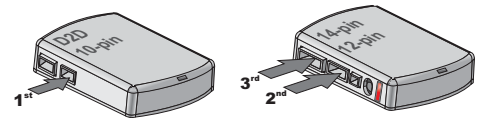

## For Key-type vehicles

- 1** Wait until the LED turns ON solid red.

**Note:** To skip the transponder programming and use convenience features only, press the programming button 5 times. The LED will turn orange then proceed to step 2.



- 2** Turn the ignition ON. The LED will flash green, then remain ON solid green for 3 seconds, then turns OFF.

**Note:** When skipping transponder programming, the LED flashes orange, then turns ON solid orange for 3 seconds, before turning OFF.



- 3** Turn the ignition OFF.



You have successfully completed the module programming sequence.

## For Push-to-Start (PTS) vehicles

- 1** Wait until the LED turns ON solid red.  
**Note:** To skip the transponder programming and use convenience features only, press the programming button 5 times. The LED will turn orange then proceed to step 2.



- 2** **Press** the Push-to-Start (PTS) button once to turn the ignition ON. The LED will flash green then remain ON solid green for 3 seconds, then turns OFF.

**Note:** When skipping transponder programming, the LED flashes orange, then turns ON solid orange for 3 seconds, before turning OFF.



- 3** Turn the ignition OFF by pressing once on the PTS button.



**You have successfully completed the module programming sequence.**

## Module Reset

A module reset will only erase programming performed in the previous steps. All settings (firmware) and settings flashed to the module using the web config tool will not be affected.

### D2D Installation

If required for your installation, connect the 10-pin, 12-pin & 14-pin harnesses to the module. Press and hold the programming button, then connect the 4-pin D2D harness.

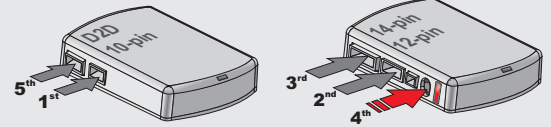

1 **OR**

### W2W Installation

If required for your installation, connect the 10-pin & 12-pin harnesses to the module. Press and hold the programming button, then connect the 14-pin harness to the module.

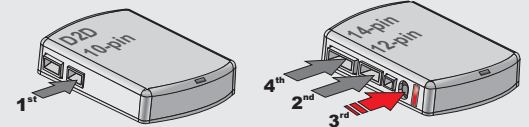

2 Wait 3 seconds until the LED turns ON solid orange then release the programming button. The LED then turns ON solid red.



## Hard Reset

### Warning Against Executing a Hard Reset!

A hard reset will revert the flashed firmware back to its default settings. Depending on the installation, some settings (such as RFTD and D2D options) may have to be reconfigured. See the **Feature & Option List** section of this guide.

### D2D Installation

If required for your installation, connect the 10-pin, 12-pin & 14-pin harnesses to the module. Press and hold the programming button, then connect the 4-pin D2D harness.

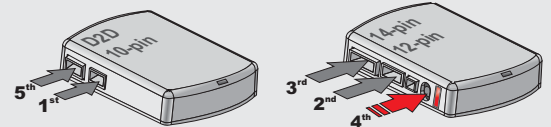

1 **OR**

### W2W Installation

If required for your installation, connect the 10-pin & 12-pin harnesses to the module. Press and hold the programming button, then connect the 14-pin harness to the module.

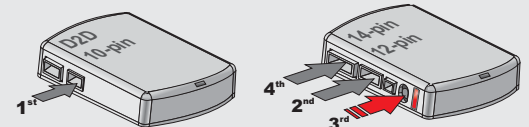

2 Wait 3 seconds until the LED turns ON solid orange, and wait 10 more seconds until the LED starts to flash orange and red.



3 Release the programming button. The LED turns ON solid red.



## Feature & Option List

It is recommended to configure all the features and options listed below using the configuration tool found on the module flashing page on [www.directechs.com](http://www.directechs.com). The web offers more options; however, manual configuration of the features is possible using the information on this page.

\* Default Option

Feat.	Operation	Flashes/Options	Description
1	RFTD Output Type	<b>1. No RF Output*</b>	Module is connected to a remote starter using a standard installation.
		2. RFTD Output	Module is connected to an XL202 using an RSR or RXT installation (when available).
		3. SmartStart	Module is connected to SmartStart using an RSR or RXT installation (when available).
2	OEM Remote Starter Equipped	<b>1. Without OEM Remote Starter*</b>	The vehicle is equipped with a OEM Remote Start System.
		2. With OEM Remote Started	The vehicle is <b>NOT</b> equipped with a OEM Remote Start System.

## Feature Programming



### To enter feature programming routine

- Turn the ignition ON, then OFF.
- **Within 5 seconds**, press and HOLD the programming button until the LED turns ON orange (after 3 seconds). Release the Programming button.
- The LED will flash green once slowly to indicate the feature number is 1. After a short delay, the LED flashes red rapidly to indicate the current option of feature 1 (i.e. 1x green followed by 1x red indicates feature 1 is set to option 1). The flashing sequence will repeat until a new command is entered.

### Changing feature options

- Press the lock/arm or unlock/disarm button on aftermarket transmitter to change the option of the selected feature.
- The LED flashes red rapidly the number of times equal to the current option number. After a short delay, the LED flashes green slowly the number of times to indicate the current feature. The flashing sequence will repeat until a new command is entered.

### Accessing another feature

- Press and release the programming button a number of times to advance from the current feature to the next desired feature.
- The LED flashes green slowly the number of times equal to the feature number. After a short delay, the LED flashes red rapidly to indicate the current option of the current feature. The flashing sequence will repeat until a new command is entered.

**When the maximum number of features or options is reached, the LED will start flashing again from the first feature or option.**

















### Once a feature is programmed

- Other features can be programmed.
- The feature programming can be exited.

### Exiting feature programming

















- No activity for 30 seconds; after 30 seconds, the LED will turn ON orange for 2 seconds to confirm the end of the programming sequence.  
OR
- Press and HOLD the programming button for 3 seconds. After 3 seconds, the LED will turn ON orange for 2 seconds to confirm the end of the programming sequence.

## LED Diagnostics & Troubleshooting

LED	Description	Troubleshooting
<b>Module Programming</b>		
 Off	Module has no power.	Make sure the D2D harness is connected or that the 12 Volt is present between the red and black wires. If the 12 Volt is present, the module may be defective.
 Solid red	Waiting to begin the programming sequence.	Ensure the correct programming procedure is being followed.
 Flashes red & green	Initialization failed.	Reset the module and complete the programming again. If the issue persists, please contact Technical Support.
 Solid orange	Transponder functions were skipped.	(If compatible) when RXT mode is not desired or convenience features are needed, please reset and reprogram the module.
 Flashes green	All required CAN networks has been detected.	Normal operation.
 Flashes orange	1 of 2 CAN networks has been detected.	Normal operation
 Flashes orange slowly	Key2GO initiated.	Please follow the steps indicated in "Module programming" to complete the Key2GO programming.
 Solid green x 3 secs	Module was successfully programmed with all functions.	Normal operation
 Solid orange x 3 secs	Module was successfully programmed without transponder functions.	Normal operation.
<b>Module Programming - Error Codes</b>		
 Flashes red x 1	CAN2 not detected.	Check the CAN2 Orange/Green and Orange/Brown wire connections. Wake up the data bus by turning the ignition on and try again. If your installation does not require this connection, skip this step by pressing the programming button 5 times.
 Flashes red x 1	J1850 not detected.	Check the J1850 wire connection. Wake up the data bus by turning the ignition on and try again.
 Flashes red x 2	CAN1 not detected.	Check the CAN1 Tan and Tan/Black wire connections. Wake up the data bus by turning the ignition on and try again. If your installation does not require this connection, skip this step by pressing the programming button 5 times.
 Flashes red x 3	Bypass data not detected.	Check the bypass line connection. If more than one wire is used, make sure they are not inverted. Ensure the vehicle still operates correctly using the factory key.
 Flashes red x 4	Bypass processing error.	The bypass calculation failed. Reset the module and try again. If the condition persists, please contact Technical Support.
 Flashes red x 5	ISO 1 not detected.	The Yellow/Black wire did not detect the expected signal. Refer to "Installation (wiring diagrams & vehicle wiring reference charts)" to check the connections.
 Flashes red x 6	ISO 2 not detected.	The Orange/Black wire did not detect the expected signal. Refer to "Installation (wiring diagrams & vehicle wiring reference charts)" to check the connections.
 Flashes red x 7	MUX not detected.	The Violet/Green or Violet/Brown wire did not detect the expected voltage value. Refer to "Installation (wiring diagrams & vehicle wiring reference charts)" to check the connections.



## LED Diagnostics & Troubleshooting

LED	Description	Troubleshooting
<b>External module synchronization</b>		
 (Flashes red, red then orange) x 10	OBDDII feature is not supported.	The diagnostic data bus was not detected, therefore the SmartStart features will be limited.
<b>Activation Ground When Running (Status)</b>		
 Flashes green	Ground When Running (Status) command received.	The module has initialized the remote start sequence.
 Flashes red & orange	Ignition ON command received.	The module has received the Ignition ON command and is processing the remote start sequence.
 Flashes green quickly	Start ON command received.	The module has received the Start ON command and is processing the remote start sequence.
 Flashes red x 10	PTS shutdown error.	The PTS output from the module was not activated due to safety protection.
 Flashes red x 21	CAN bus incorrectly detected.	Verify the CAN1 and CAN2 connections. Refer to "Installation (wiring diagrams & vehicle wiring reference charts)" to check the connections.
<b>Commands</b>		
 Flashes orange x 1	LOCK command received.	If the bypass module fails to flash, it did not receive the signal. Commands can come from RF or D2D.
 Flashes orange x 2	UNLOCK command received.	
 Flashes orange x 3	TRUNK command received.	
 Flashes orange x 4	AUX1 command received.	
 Flashes orange x 5	AUX2 command received.	
 Flashes orange x 6	AUX3 command received.	
<b>Shutdown codes</b>		
 Flashes green x 1	Takeover successful.	Normal operation.
 Flashes red x 1	Runsafes was not disabled.	No UNLOCK command was received prior to opening the door, or the 45 second timer expired in takeover mode.
 Flashes red x 2	Brake was not detected.	The brakes were not detected, which prevents the system from shutting down the vehicle.
 Flashes red x 3	Smart key was not detected.	The smart key was not detected, which prevents the system from shutting down the vehicle.
 Flashes red x 4	Speed was detected.	The vehicle was detected as moving, which prevents the system from shutting it down.

## Limited One Year Consumer Warranty

For a period of ONE YEAR from the date of purchase of a Directed Electronics remote start or security product, Directed Electronics. ("DIRECTED") promises to the original purchaser, to repair or replace with a comparable reconditioned piece, the security or remote start accessory piece (hereinafter the "Part"), which proves to be defective in workmanship or material under normal use, provided the following conditions are met: the Part was purchased from an authorized DIRECTED dealer; and the Part is returned to DIRECTED, postage prepaid, along with a clear, legible copy of the receipt or bill of sale bearing the following information: consumer's name, address, telephone number, the authorized licensed dealer's name and complete product and Part description.

This warranty is nontransferable and is automatically void if the Part has been modified or used in a manner contrary to its intended purpose or the Part has been damaged by accident, unreasonable use, neglect, improper service, installation or other causes not arising out of defect in materials or construction.

TO THE MAXIMUM EXTENT ALLOWED BY LAW, EXCEPT AS STATED ABOVE, ALL WARRANTIES, INCLUDING BUT NOT LIMITED TO EXPRESS WARRANTY, IMPLIED WARRANTY, WARRANTY OF MERCHANTABILITY, FITNESS FOR PARTICULAR PURPOSE AND WARRANTY OF NONINFRINGEMENT OF INTELLECTUAL PROPERTY, ARE EXPRESSLY EXCLUDED; AND DIRECTED NEITHER ASSUMES NOR AUTHORIZES ANY PERSON OR ENTITY TO ASSUME FOR IT ANY DUTY, OBLIGATION OR LIABILITY IN CONNECTION WITH ITS PRODUCTS. DIRECTED HEREBY DISCLAIMS AND HAS ABSOLUTELY NO LIABILITY FOR ANY AND ALL ACTS OF THIRD PARTIES INCLUDING DEALERS OR INSTALLERS. DIRECTED IS NOT OFFERING A GUARANTEE OR INSURANCE AGAINST VANDALISM, DAMAGE, OR THEFT OF THE AUTOMOBILE, ITS PARTS OR CONTENTS, AND DIRECTED HEREBY DISCLAIMS ANY LIABILITY WHATSOEVER, INCLUDING WITHOUT LIMITATION, LIABILITY FOR THEFT, DAMAGE, OR VANDALISM. IN THE EVENT OF A CLAIM OR A DISPUTE INVOLVING DIRECTED OR ITS SUBSIDIARY, THE PROPER VENUE SHALL BE SAN DIEGO COUNTY IN THE STATE OF CALIFORNIA. CALIFORNIA STATE LAWS AND APPLICABLE FEDERAL LAWS SHALL APPLY AND GOVERN THE DISPUTE. THE MAXIMUM RECOVERY UNDER ANY CLAIM AGAINST DIRECTED SHALL BE STRICTLY LIMITED TO THE AUTHORIZED DIRECTED DEALER'S PURCHASE PRICE OF THE PART. DIRECTED SHALL NOT BE RESPONSIBLE FOR ANY DAMAGES WHATSOEVER, INCLUDING BUT NOT LIMITED TO, ANY CONSEQUENTIAL DAMAGES, INCIDENTAL DAMAGES, DAMAGES FOR THE LOSS OF TIME, LOSS OF EARNINGS, COMMERCIAL LOSS, LOSS OF ECONOMIC OPPORTUNITY AND THE LIKE. NOTWITHSTANDING THE ABOVE, THE MANUFACTURER DOES OFFER A LIMITED WARRANTY TO REPLACE OR REPAIR AT DIRECTED'S OPTION THE PART AS DESCRIBED ABOVE.

This warranty only covers Parts sold within the United States of America and Canada. Parts sold outside of the United States of America or Canada are sold "AS-IS" and shall have NO WARRANTY, express or implied. Some states do not allow limitations on how long an implied warranty will last or the exclusion or limitation of incidental or consequential damages. This warranty gives you specific legal rights and you may also have other rights that vary from State to State. DIRECTED does not and has not authorized any person or entity to create for it any other obligation, promise, duty or obligation in connection with this Part. For further details relating to warranty information of Directed products, please visit the support section of DIRECTED's website at: [www.directed.com](http://www.directed.com)

920-10012-01 2013-07

This Interface kit / Data Bus Interface part has been tested on the listed vehicles. Other vehicles will be added to the select vehicle list upon completion of compatibility testing. Visit website for latest vehicle application guide. DISCLAIMER: Under no circumstances shall the manufacturer or the distributors of the bypass kit / data bus interface part(s) be held liable for any consequential damages sustained in connection with the part(s) installation. The manufacturer and its distributors will not, nor will they authorize any representative or any other individual to assume obligation or liability in relation to the interface kit / data bus interface part(s) other than its replacement. N.B.: Under no circumstances shall the manufacturer and distributors of this product be liable for consequential damages sustained in connection with this product and neither assumes nor authorizes any representative or other person to assume for it any obligation or liability other than the replacement of this product only.

Protected by U.S. Patents: 5,719,551; 6,011,460 B1 \*; 6,243,004 B1; 6,249,216 B1; 6,275,147 B1; 6,297,731 B1; 6,346,876 B1; 6,392,534 B1; 6,529,124 B2; 6,696,927 B2; 6,756,885 B1; 6,756,886 B2; 6,771,167 B1; 6,812,829 B1; 6,924,750 B1; 7,010,402 B1; 7,015,830 B1; 7,031,826 B1; 7,046,126 B1; 7,061,137 B1; 7,068,153 B1; 7,205,679 B1; Cdn. Patent: 2,320,248; 2,414,991; 2,415,011; 2,415,023; 2,415,027; 2,415,038; 2,415,041; 2,420,947; 2,426,670; 2,454,089; European Patent: 1,053,128; Pat. Pending: 2,291,306. Made in Canada.

## Vehicle Takeover with Key

**1** Press the remote start button on the transmitter to start the vehicle.\*



**2** Press the Unlock button on the factory or aftermarket remote.\*

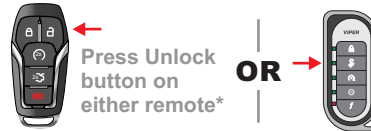

Enter the vehicle .

**3**

Insert your key in the ignition barrel and turn it to the ON position.

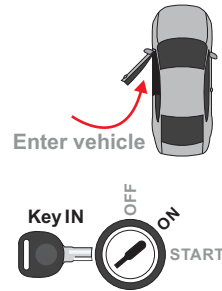

**4** Press the brake pedal, put the car in gear and drive off.



\* Your aftermarket remote may differ from the model shown in the illustrations.

## Pit stop/idle mode

The vehicle pit stop/idle mode feature is not available in this firmware.

## Vehicle Takeover (Push-to-Start)

**1** Press the remote start button on the transmitter to start the vehicle.\*



**2** Press the Unlock button on the factory or aftermarket remote.\*



Complete the following steps within 45 seconds or the vehicle will shut down.

Enter the vehicle while making sure the factory remote is inside with you.

**3**



Press the Push-to-Start (PTS) button once.













**4** Press the brake pedal, put the car in gear and drive off.



\* Your aftermarket remote may differ from the model shown in the illustrations.

## List of Available Commands

Note that the information below is for Viper, Clifford and Python models. Icons and commands may differ depending on the remote brand and model purchased. Refer to your authorized installation center for more information.

Button(s)	Actions
	Press & hold for 1 second to lock.
	Press & hold for 1 second to unlock.
	Press & hold for 1 second to remote start.
	Press & hold for 5 seconds to activate the trunk release (optional).
<i>f</i> x1 + 	Press <i>f</i> once, then  to activate the rear hatch/tail glass release (optional).*
<i>f</i> x3 + 	Press <i>f</i> 3 times, then  to activate the panic mode.
<i>f</i> x1 + 	Press <i>f</i> once, then  to reset the remote starter runtime.

\* This output is configurable. see your authorized installation center for more information.

## Notes

---

---

---

---

---

---

---

---

---

---