

Use Your Tower as a Dual-Band DX Antenna for 75/80 and 160 Meters

Theodore (Ted) S. Rappaport, N9NB

and

James (Jim) Parnell, W5JAW

<http://tinyurl.com/N9NB-QST>

Dayton Hamvention
Antenna Forum by K3LR
Friday May 17, 2019



- **Motivation for this Antenna**
- **Basic Concepts of a Dual Band vertical antenna**
- **Computer Modeling and Novel Design**
- **Construction of Antenna**
- **Tuning and real-world implementation**
- **Results and Conclusion**

Motivation for this Antenna



Motivation for this Antenna



- **Very windy! The 160 m Inverted-L tied to tree came down often**
- **~ 250' - 300' ground slope from JA to EU**
- **Two towers and trees only 65' – 80' tall**
- **80 m and 160 m dipoles did not perform well– too low?**
- **30 ground radials (~ 50' each) installed for eventual vertical use.**
- **Needed a low-maintenance, low-profile performer**

Past 160 m solutions motivated me to solve the wind and performance problems at the N9NB ridge top location:

- **A low-profile 160 m antenna in college for my apartment:
“T. S. Rappaport, “160 meter transmission line antenna,” Ham Radio Magazine, May 1985, pp. 87-91**
- **K9RS achieved gain using a parasitic tower on his 4-square:
R. Sokola, T. S. Rappaport, “Multi-element low band vertical arrays – approaches for small and other lots,” 2008 Dayton Antenna Forum**

One day at lunch in Austin, Texas in November 2017.....

- **W5JAW had modeled N3BB's tower for a 160 m shunt fed vertical**
- **I had been trying to figure out a single-feed dual band vertical for years.....**
 - Investigated parasitic 80 m verticals next to 160 m but always 1 - 3 dB loss
- **Inspiration struck as W5JAW and I tried different EZNEC concepts**
- **For 160 m shunt feed, a parallel wire located a few feet away can work on 80m**
 - Much lower impedance (about 12 ohms)
 - Only 0.2- 0.5 dB loss from modeled ideal vertical performance, need 1:4 unun

- **Single feedline for multiple bands is convenient and cost-efficient**
- **Some multi-band dipoles do not require any traps or tuners or switches**
- **Resonance for one band should not be “bothered” by the other bands**
- **I had been using a single feed dual band dipole for 80/160 m at N9NB**
- **80 m dipole is electrically short, high Z (cap) in parallel to 160 m feed**
- **160 m dipole has high Z (resistive) in parallel to 80 m feed**



- **First step**: Find resonance of tower – used EZNEC for base current feed
- Once we knew the tower could be shunt fed, 160 m was solved (ON4UN)
- **Second step**: Found proper spacing and length of parallel 80 m vertical wire
- **Third step**: Realized 80 m vertical used a 12-15 ohm feed impedance (1:4)
- Single feed with standard 1:4 Unun (80 m) and parallel “hot center” for 160 m
- **Fourth step**: Realized sensitivity at base of tower on 80 m – can tune 75/80!
- **Fifth step**: Build a single vertical and a 2 el phased array – have fun!

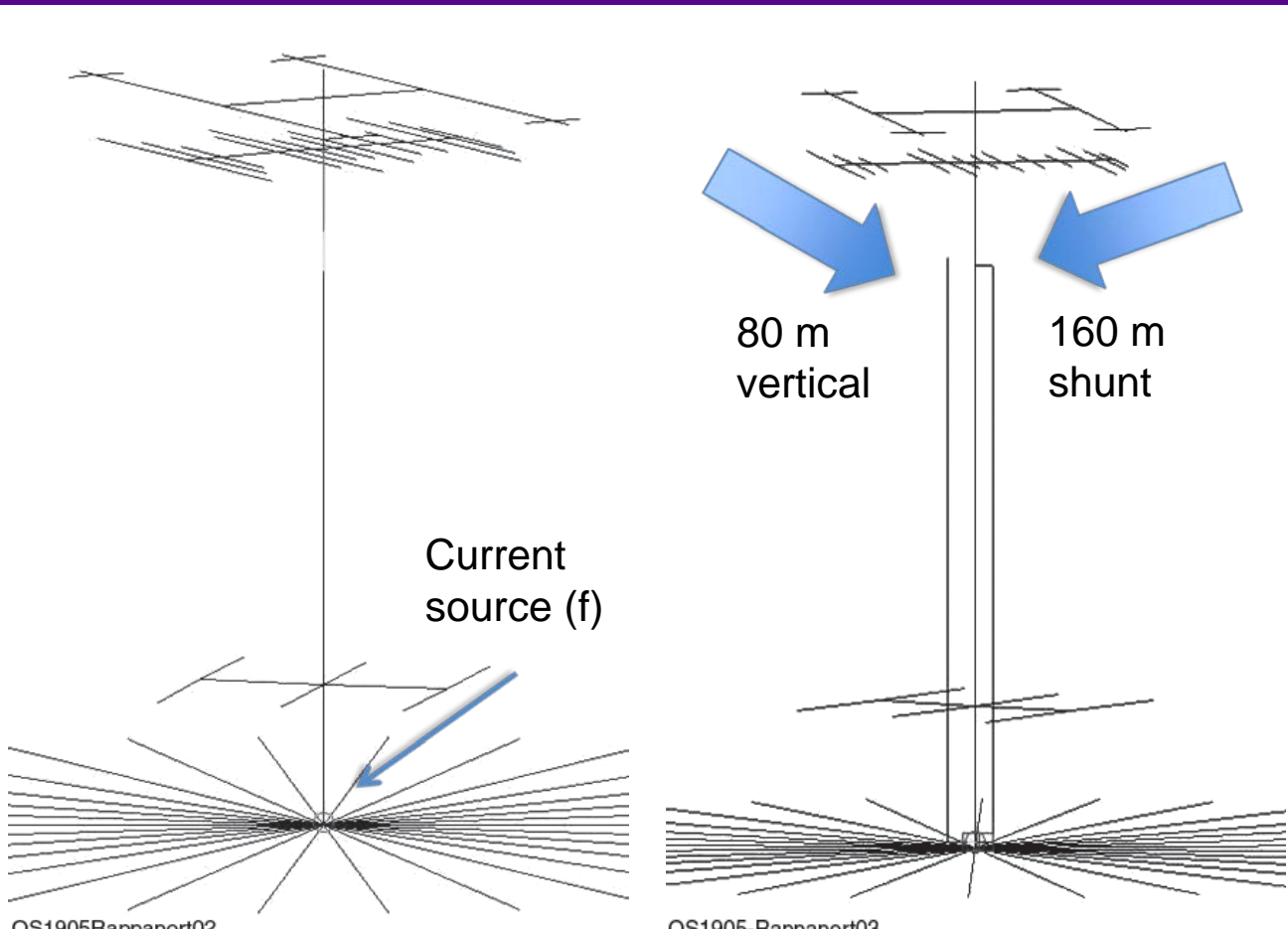

Construction of the antenna

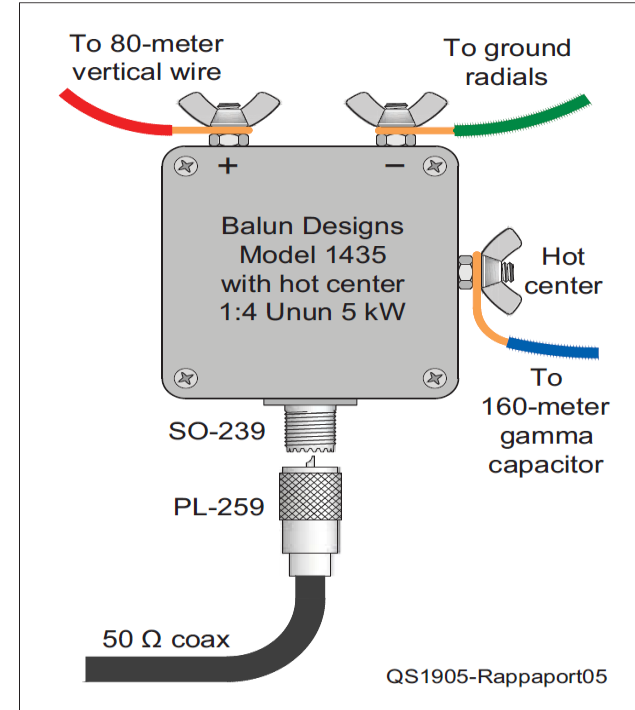
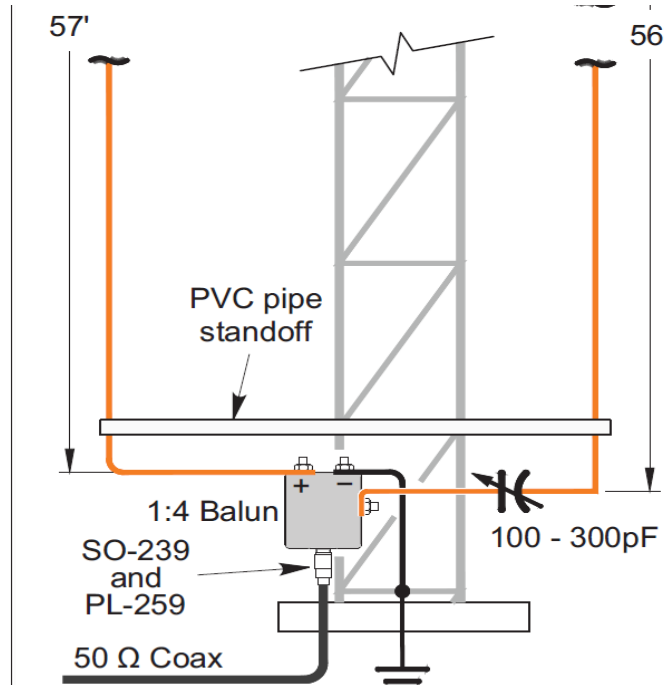
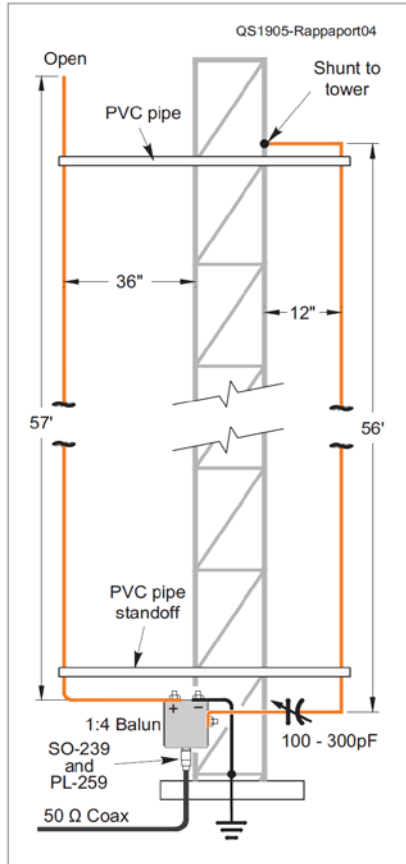

Graphics Courtesy QST Magazine, T.S. Rappaport, J. Parnell, "Use your tower as a dual band, low band DX antenna, QST, May 2019, pp. 41-45

W5JAW Center Tapped Toroid Coil Solution for insulated driven element at N3BB

Use this if You have a Yagi with insulated driven element

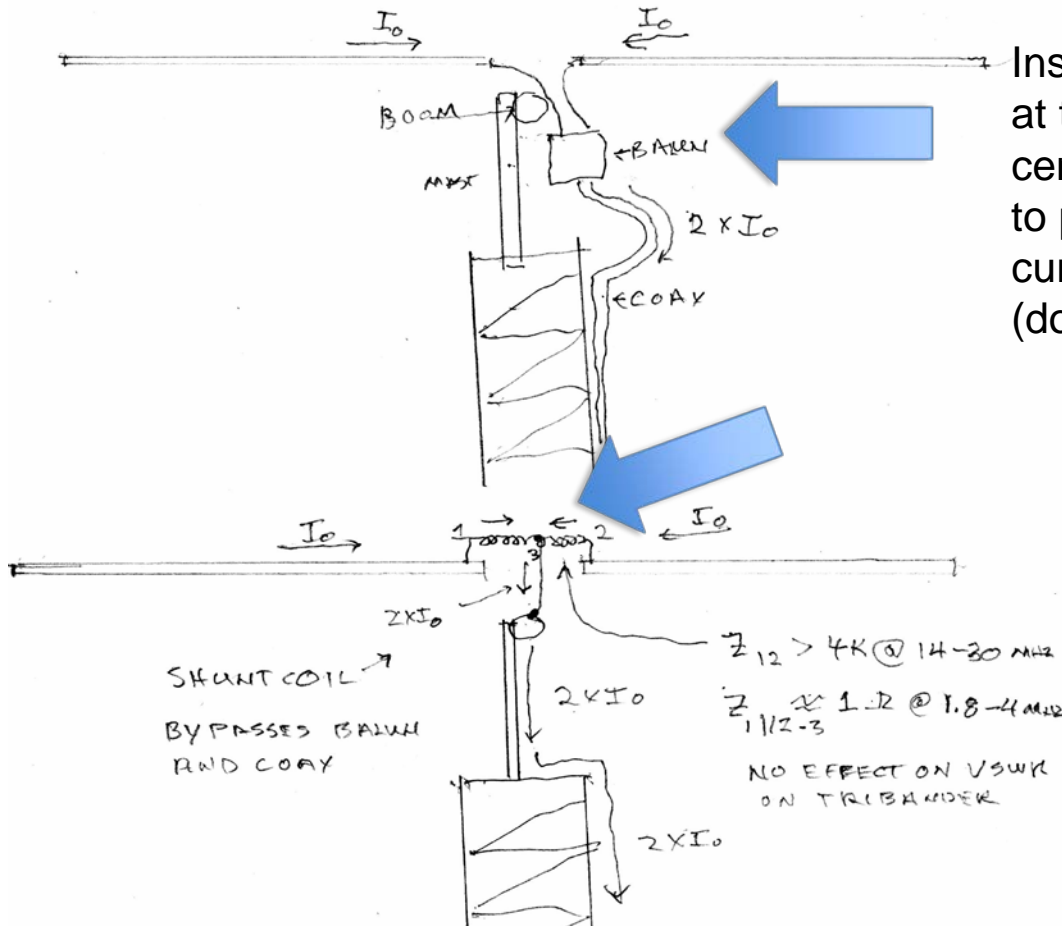

Insulated driven element at top of tower must be center shunted to tower to prevent 160 / 80 m currents on balun/coax (do this for all top yagis)

Hi Z center-tapped toroid coil shunts the driven elements to tower, bringing all currents onto tower and not on yagi balun or yagi coax

- **Center-tapped toroid coil w/balun: grounds insulated driven element**
- **W5JAW's solution eliminates 160 m currents on top yagi balun/coax**

Added center tapped toroid in parallel with stock yagi balun: the center tap shunts insulated driven elements to tower

Windings of center-tapped toroid goes across insulated top yagi driven elements, use this idea for all driven elements at top of your tower

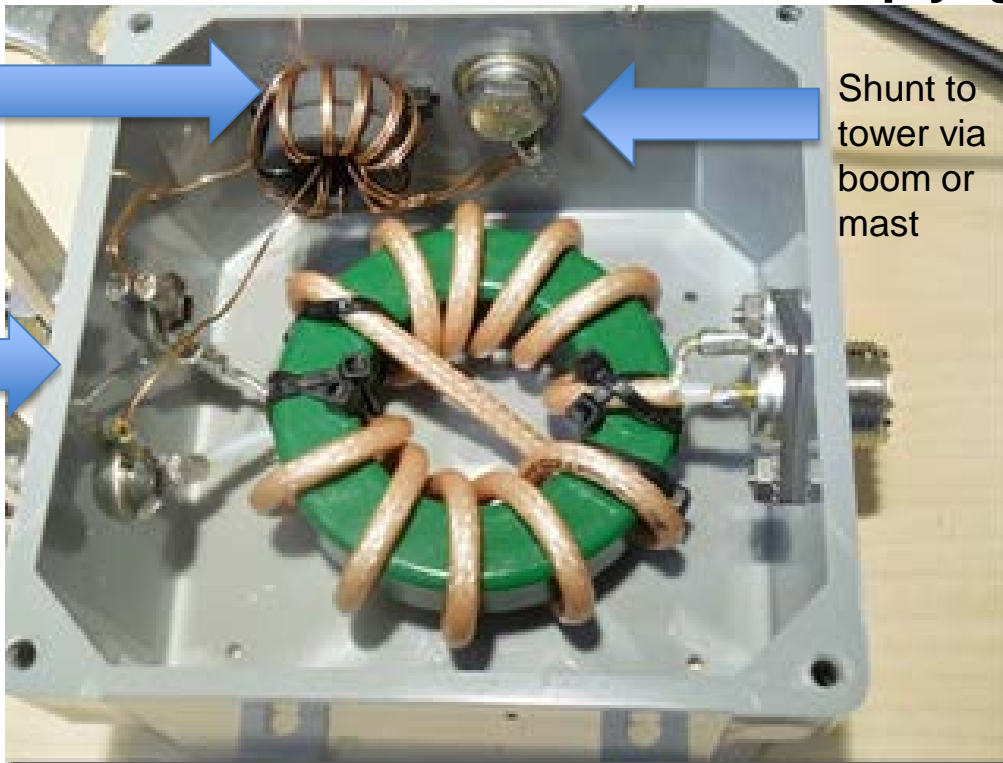

Shunt to tower via boom or mast

Core: stack of two Amidon FT-114A-61 cores w/ties. Currents in two halves of driven elements are equal and in phase, giving Zero vector sum flux in the toroid core, and Low Z to the center tap. End to end Z diff. for feed line is $4K\Omega$, no impact on 14-30 MHz SWR

- **Antenna parts cost less than \$125 for a dual band 80/160 m vertical**

Table 1
Components for the 80/160-meter vertical on a single tower

Qty	Component	Comment
1	JBX666 junction box	Manufactured by Kraloy, available at many electrical supply stores
1	5 $\frac{5}{8}$ × 6 $\frac{3}{4}$ × $\frac{1}{4}$ inch Plexiglas, Lexan, or perf board	To mount the capacitors in the junction box
2	20-foot pieces of $\frac{3}{4}$ -inch schedule 40 PVC waterpipe	These are cut into three equal lengths of 6.66 feet at the store for easy transport in a car
12	1 $\frac{5}{8}$ -inch stainless-steel hose clamps	For mounting PVC spacer pipes to horizontal tower legs
1	Variable capacitor, 1 – 130 pF, 5 kV	Rating for legal limit
1	Doorknob capacitor, 180 pF, 5 kV	Rating for legal limit, available from Surplus Sales, Omaha, NE
1	Model 1435 1:4 unun with added hot center tap	Available from Balun Designs, Denton, TX
—	Assorted #12 AWG wire and lugs for vertical wires	To enable connections shown in Figures 3 and 4

Graphic Courtesy QST Magazine, T.S. Rappaport, J. Parnell, “Use your tower as a dual band, low band DX antenna, QST, Vol. 103, No. 5, May 2019, pp. 41-45

- **Gamma Match capacitor construction**

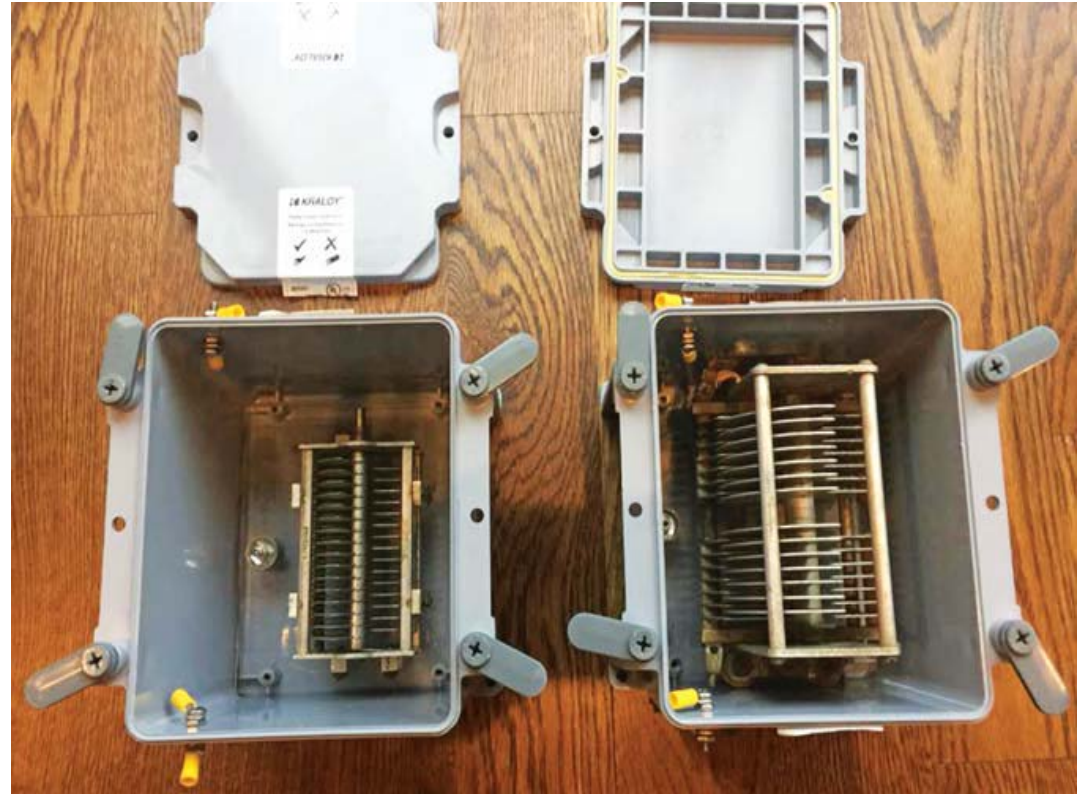
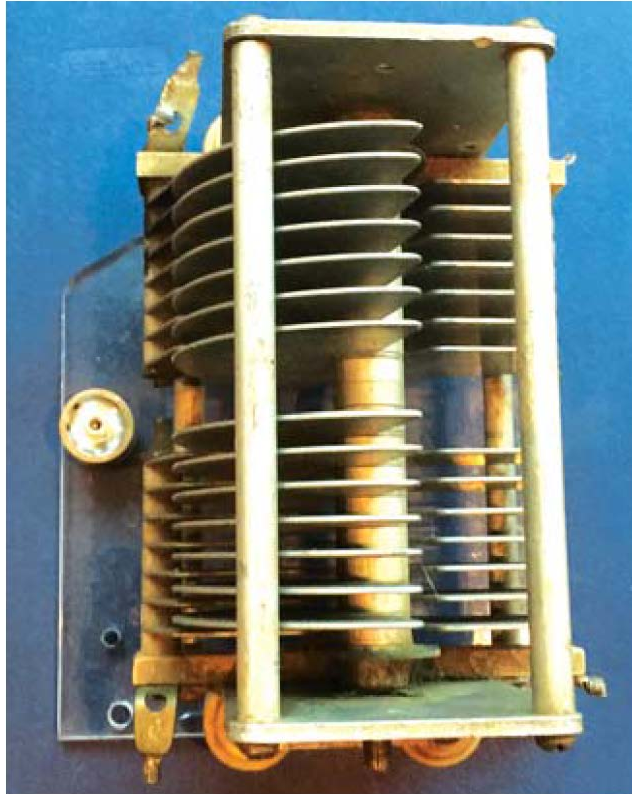

Construction of the antenna



- **First: Tune 160 M Gamma match height and Cap with 80 m/unun connected**
- **Second: Determine 80 m wire height and spacing, special care for base spacing**
- **Third: using PVC pipe as a core, a tight coil lowers 80 m resonant freq.**
- **Fourth: Moving 80 m wire closer to tower and uncoiling raises the freq.**

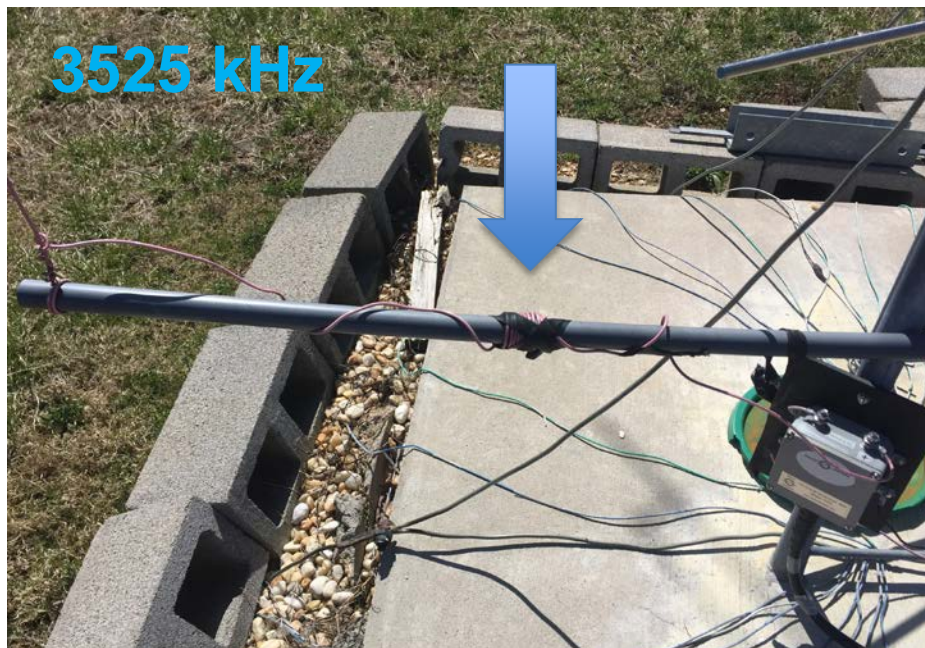

- **SWR is excellent over 100 kHz range on both bands**
- **Easy to move between 3525 and 3725 khz resonance w/coil base and tie rope**
- **No tuners, traps, or moving parts!**

Table 2
Measured SWR,
160-meter band

Freq., kHz	SWR
1,800	1.4
1,825	1.1
1,850	1.2
1,875	1.6
1,900	2.1

Table 3
Measured SWR,
80-meter band

Freq., kHz	SWR
3,500	1.4
3,525	1.2
3,550	1.1
3,575	1.3
3,590	1.5
3,600	1.9

Graphics Courtesy QST Magazine

T.S. Rappaport, J. Parnell, "Use your tower as a dual band, low band DX antenna, QST, May 2019, pp. 41-45

- **First step**: ON4UN: estimate or measure your tower resonance for 160 shunt
- **Second step**: If insulated top yagi(s), install parallel center-tap toroid(s) to ensure proper vertical performance, and protect hi-band yagi(s) balun/coax
- **Third step**: Install single band 160 m shunt fed vertical to validate performance
- **Fourth step**: Install single coax w/1:4 Unun, 80 m wire 3' from tower || 160 shunt
- **Fifth step**: Experiment with length of 80 m wire and spacing from tower, and spacing length (and coil of wire) at base of tower on 80 m – can tune 75/80
- **Sixth step**: Confirm both 160 and 80/75 provide resonance, HAVE FUN!

- **For a Two Element dual-band phased array, use two identical vertical towers**
- **Identical 125' coax runs to each of the two towers – equal phase feeds**
- **Using a stack match in shack, I can select N, S, or BOTH**
- **N drives the N vertical for gain to the N-NW using the south tower as reflector**
- **S drives the S vertical for gain to the S-SE using the north tower as reflector**
- **Exploits parasitic reflector as in K9RS 4-square (2008 Dayton Antenna forum)**
- **BOTH drives each vertical: broadside 2 element phased array to NE and SW**

- 2 Element Phased Array gain > single element: 1.1 dB (160) and 3.8 dB (80)
- 2 Element design: Half wave spacing on 80 m, Quarter wave spacing on 160 m

Total Field

* Primary
 160M BROADSIDE
 80 M SINGLE ELEMENT
 160 M SINGLE ELEMENT

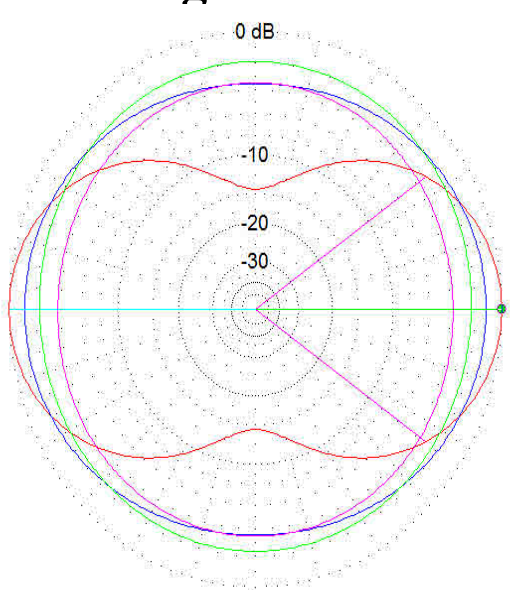

EZNEC

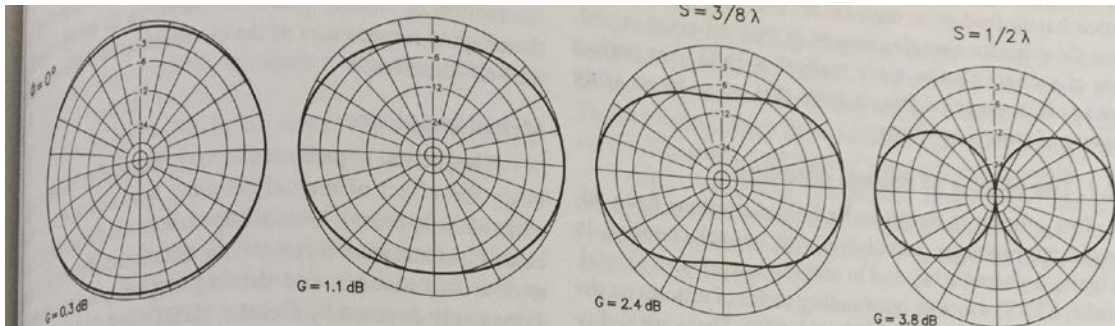

Best elevation angle depends on ground cond. (EZNEC and ON4UN): Model shows 24 deg. for 160 m and 25 deg. for 80 m. More radials will improve single element gains!

3.525 MHz

Cursor Az 0.0 deg.
 Gain 5.06 dBi
 0.0 dBmax

	160m	Single	Array	Gain
Azimuth Plot				
Elevation Angle	24.0 deg.			
Outer Ring	5.06 dBi			
Slice Max Gain	5.06 dBi @ Az Angle = 0.0 deg.			
Front/Side	14.38 dB			
Beamwidth	69.4 deg., -3dB @ 325.3, 34.7 deg.			
Sidelobe Gain	5.06 dBi @ Az Angle = 180.0 deg.			
Front/Sidelobe	0.0 dB			
	80m	1.28 dBi	5.06 dBi	3.78 dB

Does it work??? I consistently break pile ups and work what is heard w/LP

- **#3 World Low Power Stew Perry Top Band Challenge December 2018**
 - (Low Power World QSO leader, did not use any RX antenna other than the vertical!)
- **#1 US Low Power 2019 ARRL CW DX (preliminary)**
- **#1 North America Low Power 2019 Russian DX Contest (preliminary)**
- **#1 North America Low Power 2019 CQWPX SSB (preliminary)**

YES! IT WORKS !!!BUT WAIT, there's MORE.....

- **Amazingly, the antenna tunes well on almost every band: 160-6 m!**
- **EVEN WARC BANDS and 6 m without a tuner! Who would have guessed?**
- **Discovered by remote operation with limited antennas connected**
- **Worst VSWR was 5:1 on 40 m and 15 m, other bands did not need a tuner!**
- **Unexpected benefit! No telling what the patterns are – but I can work DX!**

CONCLUSION:

- **I no longer use dipoles. The tower verticals are my only 80/160 m TX Ants.**
- **These verticals are easy to make, easy to maintain, and really work well!**
- **They require no tuners, traps or switches for dual band 80/160 m operation**
- **Adding more ground radials will improve the gain even more**
- **TRY IT, YOU'LL LIKE IT!**

THANK YOU !

73

de

N9NB and W5JAW



Use this QR Code for a preprint of May 2019 QST article
about this antenna: <http://tinyurl.com/N9NB-QST>