



Clear Spot 4G+ Personal Hotspot

User Guide



SIERRA
WIRELESS



CLEAR™

2131352
Rev 1.0

Important Notice

Due to the nature of wireless communications, transmission and reception of data can never be guaranteed. Data may be delayed, corrupted (i.e., have errors) or be totally lost. Although significant delays or losses of data are rare when wireless devices such as the Sierra Wireless modem are used in a normal manner with a well-constructed network, the Sierra Wireless modem should not be used in situations where failure to transmit or receive data could result in damage of any kind to the user or any other party, including but not limited to personal injury, death, or loss of property. Sierra Wireless accepts no responsibility for damages of any kind resulting from delays or errors in data transmitted or received using the Sierra Wireless modem, or for failure of the Sierra Wireless modem to transmit or receive such data.

Safety and Hazards

Do not operate the Sierra Wireless modem in areas where blasting is in progress, where explosive atmospheres may be present, near medical equipment, near life support equipment, or any equipment which may be susceptible to any form of radio interference. In such areas, the Sierra Wireless modem **MUST BE POWERED OFF**. The Sierra Wireless modem can transmit signals that could interfere with this equipment.

Do not operate the Sierra Wireless modem in any aircraft, whether the aircraft is on the ground or in flight. In aircraft, the Sierra Wireless modem **MUST BE POWERED OFF**. When operating, the Sierra Wireless modem can transmit signals that could interfere with various onboard systems.

Note: Some airlines may permit the use of cellular phones while the aircraft is on the ground and the door is open. Sierra Wireless modems may be used at this time.

The driver or operator of any vehicle should not operate the Sierra Wireless modem while in control of a vehicle. Doing so will detract from the driver or operator's control and operation of that vehicle. In some states and provinces, operating such communications devices while in control of a vehicle is an offence.

Limitation of Liability

The information in this manual is subject to change without notice and does not represent a commitment on the part of Sierra Wireless. SIERRA WIRELESS AND ITS AFFILIATES SPECIFICALLY DISCLAIM LIABILITY FOR ANY AND ALL DIRECT, INDIRECT, SPECIAL, GENERAL, INCIDENTAL, CONSEQUENTIAL, PUNITIVE OR EXEMPLARY DAMAGES INCLUDING, BUT NOT LIMITED TO, LOSS OF PROFITS OR REVENUE OR ANTICIPATED PROFITS OR REVENUE ARISING OUT OF THE USE OR INABILITY TO USE ANY SIERRA WIRELESS PRODUCT, EVEN IF SIERRA WIRELESS AND/OR ITS AFFILIATES HAS BEEN ADVISED OF THE POSSIBILITY OF SUCH DAMAGES OR THEY ARE FORESEEABLE OR FOR CLAIMS BY ANY THIRD PARTY.

Notwithstanding the foregoing, in no event shall Sierra Wireless and/or its affiliates aggregate liability arising under or in connection with the Sierra Wireless product, regardless of the number of events, occurrences, or claims giving rise to liability, be in excess of the price paid by the purchaser for the Sierra Wireless product.

Patents

Portions of this product may be covered by some or all of the following US patents:

5,515,013	5,629,960	5,845,216	5,847,553	5,878,234	5,890,057	5,929,815
6,169,884	6,191,741	6,199,168	6,339,405	6,359,591	6,400,336	6,516,204
6,561,851	6,643,501	6,653,979	6,697,030	6,785,830	6,845,249	6,847,830
6,876,697	6,879,585	6,886,049	6,968,171	6,985,757	7,023,878	7,053,843
7,106,569	7,145,267	7,200,512	7,295,171	7,287,162	D442,170	D459,303
D599,256	D560,911					

and other patents pending.

This product includes technology licensed from QUALCOMM® 3G

Manufactured or sold by Sierra Wireless or its licensees under one or more patents licensed from InterDigital Group.

Licenses

A large amount of the source code to this product is available under licenses which are both free and open source. Most is available under the GNU General Public License.

The remainder of the open source software which is not under the GPL is available under one of a variety of more permissive licenses. Those that require reproduction of the license text in the distribution are listed in the sections that follow (starting on [page 10](#)).

GNU General Public License

Version 2, June 1991

Copyright (C) 1989, 1991 Free Software Foundation, Inc. 51 Franklin St, Fifth Floor, Boston, MA 02110-1301 USA

Everyone is permitted to copy and distribute verbatim copies of this license document, but changing it is not allowed.

Preamble

The licenses for most software are designed to take away your freedom to share and change it. By contrast, the GNU General Public License is intended to guarantee your freedom to share and change free software--to make sure the software is free for all its users. This General Public License applies to most of the Free Software Foundation's software and to any other program whose authors commit to using it. (Some other Free Software Foundation software is covered by the GNU Library General Public License instead.) You can apply it to your programs, too.

When we speak of free software, we are referring to freedom, not price. Our General Public Licenses are designed to make sure that you have the freedom to distribute copies of free software (and charge for this service if you wish), that you receive source code or can get it if you want it, that you can change the software or use pieces of it in new free programs; and that you know you can do these things.

To protect your rights, we need to make restrictions that forbid anyone to deny you these rights or to ask you to surrender the rights. These restrictions translate to certain responsibilities for you if you distribute copies of the software, or if you modify it.

For example, if you distribute copies of such a program, whether gratis or for a fee, you must give the recipients all the rights that you have. You must make sure that they, too, receive or can get the source code. And you must show them these terms so they know their rights.

We protect your rights with two steps: (1) copyright the software, and (2) offer you this license which gives you legal permission to copy, distribute and/or modify the software.

Also, for each author's protection and ours, we want to make certain that everyone understands that there is no warranty for this free software. If the software is modified by someone else and passed on, we want its recipients to know that what they have is not the original, so that any problems introduced by others will not reflect on the original authors' reputations.

Finally, any free program is threatened constantly by software patents. We wish to avoid the danger that redistributors of a free program will individually obtain patent licenses, in effect making the program proprietary. To prevent this, we have made it clear that any patent must be licensed for everyone's free use or not licensed at all.

The precise terms and conditions for copying, distribution and modification follow.

GNU GENERAL PUBLIC LICENSE

TERMS AND CONDITIONS FOR COPYING, DISTRIBUTION AND MODIFICATION

0. This License applies to any program or other work which contains a notice placed by the copyright holder saying it may be distributed under the terms of this General Public License. The "Program", below, refers to any such program or work, and a "work based on the Program" means either the Program or any derivative work under copyright law: that is to say, a work containing the Program or a portion of it, either verbatim or with modifications and/or translated into another language. (Hereinafter, translation is included without limitation in the term "modification".) Each licensee is addressed as "you".

Activities other than copying, distribution and modification are not covered by this License; they are outside its scope. The act of running the Program is not restricted, and the output from the Program is covered only if its contents constitute a work based on the Program (independent of having been made by running the Program). Whether that is true depends on what the Program does.

1. You may copy and distribute verbatim copies of the Program's source code as you receive it, in any medium, provided that you conspicuously and appropriately publish on each copy an appropriate copyright notice and disclaimer of warranty; keep intact all the notices that refer to this License and to the absence of any warranty; and give any other recipients of the Program a copy of this License along with the Program.

You may charge a fee for the physical act of transferring a copy, and you may at your option offer warranty protection in exchange for a fee.

2. You may modify your copy or copies of the Program or any portion of it, thus forming a work based on the Program, and copy and distribute such modifications or work under the terms of Section 1 above, provided that you also meet all of these conditions: a) You must cause the modified files to carry prominent notices

stating that you changed the files and the date of any change. b) You must cause any work that you distribute or publish, that in whole or in part contains or is derived from the Program or any part thereof, to be licensed as a whole at no charge to all third parties under the terms of this License. c) If the modified program normally reads commands interactively when run, you must cause it, when started running for such interactive use in the most ordinary way, to print or display an announcement including an appropriate copyright notice and a notice that there is no warranty (or else, saying that you provide a warranty) and that users may redistribute the program under these conditions, and telling the user how to view a copy of this License. (Exception: if the Program itself is interactive but does not normally print such an announcement, your work based on the Program is not required to print an announcement.)

These requirements apply to the modified work as a whole. If identifiable sections of that work are not derived from the Program, and can be reasonably considered independent and separate works in themselves, then this License, and its terms, do not apply to those sections when you distribute them as separate works. But when you distribute the same sections as part of a whole which is a work based on the Program, the distribution of the whole must be on the terms of this License, whose permissions for other licensees extend to the entire whole, and thus to each and every part regardless of who wrote it.

Thus, it is not the intent of this section to claim rights or contest your rights to work written entirely by you; rather, the intent is to exercise the right to control the distribution of derivative or collective works based on the Program.

In addition, mere aggregation of another work not based on the Program with the Program (or with a work based on the Program) on a volume of a storage or distribution medium does not bring the other work under the scope of this License.

3. You may copy and distribute the Program (or a work based on it, under Section 2) in object code or executable form under the terms of Sections 1 and 2 above provided that you also do one of the following: a) Accompany it with the complete corresponding machine-readable source code, which must be distributed under the terms of Sections 1 and 2 above on a medium customarily used for software interchange; or, b) Accompany it with a written offer, valid for at least three years, to give any third party, for a charge no more than your cost of physically performing source distribution, a complete machine-readable copy of the corresponding source code, to be distributed under the terms of Sections 1 and 2 above on a medium customarily used for software interchange; or, c) Accompany it with the information you received as to the offer to distribute corresponding source code. (This alternative is allowed only for noncommercial distribution and only if you received the program in object code or executable form with such an offer, in accord with Subsection b above.)

The source code for a work means the preferred form of the work for making modifications to it. For an executable work, complete source code means all the source code for all modules it contains, plus any associated interface definition files, plus the scripts used to control compilation and installation of the executable. However, as a special exception, the source code distributed need not include anything that is normally distributed (in either source or binary form) with the major components (compiler, kernel, and so on) of the operating system on which the executable runs, unless that component itself accompanies the executable.

If distribution of executable or object code is made by offering access to copy from a designated place, then offering equivalent access to copy the source code from the same place counts as distribution of the source code, even though third parties are not compelled to copy the source along with the object code.

4. You may not copy, modify, sublicense, or distribute the Program except as expressly provided under this License. Any attempt otherwise to copy, modify, sublicense or distribute the Program is void, and will automatically terminate your rights under this License. However, parties who have received copies, or rights, from you under this License will not have their licenses terminated so long as such parties remain in full compliance.

5. You are not required to accept this License, since you have not signed it. However, nothing else grants you permission to modify or distribute the Program or its derivative works. These actions are prohibited by law if you do not accept this License. Therefore, by modifying or distributing the Program (or any work based on the Program), you indicate your acceptance of this License to do so, and all its terms and conditions for copying, distributing or modifying the Program or works based on it.

6. Each time you redistribute the Program (or any work based on the Program), the recipient automatically receives a license from the original licensor to copy, distribute or modify the Program subject to these terms and conditions. You may not impose any further restrictions on the recipients' exercise of the rights granted herein. You are not responsible for enforcing compliance by third parties to this License.

7. If, as a consequence of a court judgment or allegation of patent infringement or for any other reason (not limited to patent issues), conditions are imposed on you (whether by court order, agreement or otherwise) that contradict the conditions of this License, they do not excuse you from the conditions of this License. If you cannot distribute so as to satisfy simultaneously your obligations under this License and any other pertinent obligations, then as a consequence you may not distribute the Program at all. For example, if a patent license would not permit royalty-free redistribution of the Program by all those who receive copies directly or indirectly through you, then the only way you could satisfy both it and this License would be to refrain entirely from distribution of the Program.

If any portion of this section is held invalid or unenforceable under any particular circumstance, the balance of the section is intended to apply and the section as a whole is intended to apply in other circumstances.

It is not the purpose of this section to induce you to infringe any patents or other property right claims or to contest validity of any such claims; this section has the sole purpose of protecting the integrity of the free software distribution system, which is implemented by public license practices. Many people have made generous contributions to the wide range of software distributed through that system in reliance on consistent application of that system; it is up to the author/donor to decide if he or she is willing to distribute software through any other system and a licensee cannot impose that choice.

This section is intended to make thoroughly clear what is believed to be a consequence of the rest of this License.

8. If the distribution and/or use of the Program is restricted in certain countries either by patents or by copyrighted interfaces, the original copyright holder who places the Program under this License may add an explicit geographical distribution limitation excluding those countries, so that distribution is permitted only in or among countries not thus excluded. In such case, this License incorporates the limitation as if written in the body of this License.

9. The Free Software Foundation may publish revised and/or new versions of the General Public License from time to time. Such new versions will be similar in spirit to the present version, but may differ in detail to address new problems or concerns.

Each version is given a distinguishing version number. If the Program specifies a version number of this License which applies to it and “any later version”, you have the option of following the terms and conditions either of that version or of any later version published by the Free Software Foundation. If the Program does not specify a version number of this License, you may choose any version ever published by the Free Software Foundation.

10. If you wish to incorporate parts of the Program into other free programs whose distribution conditions are different, write to the author to ask for permission. For software which is copyrighted by the Free Software Foundation, write to the Free Software Foundation; we sometimes make exceptions for this. Our decision will be guided by the two goals of preserving the free status of all derivatives of our free software and of promoting the sharing and reuse of software generally.

NO WARRANTY

11. BECAUSE THE PROGRAM IS LICENSED FREE OF CHARGE, THERE IS NO WARRANTY FOR THE PROGRAM, TO THE EXTENT PERMITTED BY APPLICABLE LAW. EXCEPT WHEN OTHERWISE STATED IN WRITING THE COPYRIGHT HOLDERS AND/OR OTHER PARTIES PROVIDE THE PROGRAM “AS IS” WITHOUT WARRANTY OF ANY KIND, EITHER EXPRESSED OR IMPLIED, INCLUDING, BUT NOT LIMITED TO, THE IMPLIED WARRANTIES OF MERCHANTABILITY AND FITNESS FOR A PARTICULAR PURPOSE. THE ENTIRE RISK AS TO THE QUALITY AND PERFORMANCE OF THE PROGRAM IS WITH YOU. SHOULD THE PROGRAM PROVE DEFECTIVE, YOU ASSUME THE COST OF ALL NECESSARY SERVICING, REPAIR OR CORRECTION.

12. IN NO EVENT UNLESS REQUIRED BY APPLICABLE LAW OR AGREED TO IN WRITING WILL ANY COPYRIGHT HOLDER, OR ANY OTHER PARTY WHO MAY MODIFY AND/OR REDISTRIBUTE THE PROGRAM AS PERMITTED ABOVE, BE LIABLE TO YOU FOR DAMAGES, INCLUDING ANY GENERAL, SPECIAL, INCIDENTAL OR CONSEQUENTIAL DAMAGES ARISING OUT OF THE USE OR INABILITY TO USE THE PROGRAM (INCLUDING BUT NOT LIMITED TO LOSS OF DATA OR DATA BEING RENDERED INACCURATE OR LOSSES SUSTAINED BY YOU OR THIRD PARTIES OR A FAILURE OF THE PROGRAM TO OPERATE WITH ANY OTHER PROGRAMS), EVEN IF SUCH HOLDER OR OTHER PARTY HAS BEEN ADVISED OF THE POSSIBILITY OF SUCH DAMAGES.

END OF TERMS AND CONDITIONS

How to Apply These Terms to Your New Programs

If you develop a new program, and you want it to be of the greatest possible use to the public, the best way to achieve this is to make it free software which everyone can redistribute and change under these terms.

To do so, attach the following notices to the program. It is safest to attach them to the start of each source file to most effectively convey the exclusion of warranty; and each file should have at least the "copyright" line and a pointer to where the full notice is found.

```
<one line to give the program's name and a brief idea
of what it does.>
Copyright (C) <year> <name of author>

This program is free software; you can redistribute it
and/or modify it under the terms of the GNU General
Public License as published by the Free Software
Foundation; either version 2 of the License, or (at
your option) any later version.

This program is distributed in the hope that it will be
useful, but WITHOUT ANY WARRANTY; without even the
implied warranty of MERCHANTABILITY or FITNESS FOR A
PARTICULAR PURPOSE. See the GNU General Public License
for more details.

You should have received a copy of the GNU General
Public License along with this program; if not, write
to the Free Software Foundation, Inc., 51 Franklin St,
Fifth Floor, Boston, MA 02110-1301 USA
```

Also add information on how to contact you by electronic and paper mail.

If the program is interactive, make it output a short notice like this when it starts in an interactive mode:

```
Gnomovision version 69, Copyright (C) year name of
author

Gnomovision comes with ABSOLUTELY NO WARRANTY; for
details type 'show w'.

This is free software, and you are welcome to
redistribute it under certain conditions; type 'show c'
for details.
```

The hypothetical commands 'show w' and 'show c' should show the appropriate parts of the General Public License. Of course, the commands you use may be called something other than 'show w' and 'show c'; they could even be mouse-clicks or menu items--whatever suits your program.

You should also get your employer (if you work as a programmer) or your school, if any, to sign a "copyright disclaimer" for the program, if necessary. Here is a sample; alter the names:

```
Yoyodyne, Inc., hereby disclaims all copyright interest
in the program 'Gnomovision' (which makes passes at
compilers) written by James Hacker.
```

<signature of Ty Coon>, 1 April 1989
Ty Coon, President of Vice

This General Public License does not permit incorporating your program into proprietary programs. If your program is a subroutine library, you may consider it more useful to permit linking proprietary applications with the library. If this is what you want to do, use the GNU Library General Public License instead of this License.

iPerf License

Copyright (c) 1999-2007, The Board of Trustees of the University of Illinois
All Rights Reserved.

Iperf performance test

Mark Gates

Ajay Tirumala

Jim Ferguson

Jon Dugan

Feng Qin

Kevin Gibbs

John Estabrook

National Laboratory for Applied Network Research

National Center for Supercomputing Applications

University of Illinois at Urbana-Champaign

<http://www.ncsa.uiuc.edu>

Permission is hereby granted, free of charge, to any person obtaining a copy of this software (Iperf) and associated documentation files (the "Software"), to deal in the Software without restriction, including without limitation the rights to use, copy, modify, merge, publish, distribute, sublicense, and/or sell copies of the Software, and to permit persons to whom the Software is furnished to do so, subject to the following conditions:

Redistributions of source code must retain the above copyright notice, this list of conditions and the following disclaimers.

Redistributions in binary form must reproduce the above copyright notice, this list of conditions and the following disclaimers in the documentation and/or other materials provided with the distribution.

Neither the names of the University of Illinois, NCSA, nor the names of its contributors may be used to endorse or promote products derived from this Software without specific prior written permission. THE SOFTWARE IS PROVIDED "AS IS", WITHOUT WARRANTY OF ANY KIND, EXPRESS OR IMPLIED, INCLUDING BUT NOT LIMITED TO THE WARRANTIES OF MERCHANTABILITY, FITNESS FOR A PARTICULAR PURPOSE AND

NONINFRINGEMENT. IN NO EVENT SHALL THE CONTRIBUTORS OR COPYRIGHT HOLDERS BE LIABLE FOR ANY CLAIM, DAMAGES OR OTHER LIABILITY, WHETHER IN AN ACTION OF CONTRACT, TORT OR OTHERWISE, ARISING FROM, OUT OF OR IN CONNECTION WITH THE SOFTWARE OR THE USE OR OTHER DEALINGS IN THE SOFTWARE.

miniupnpd License

Copyright (c) 2006-2008, Thomas BERNARD

All rights reserved.

Redistribution and use in source and binary forms, with or without modification, are permitted provided that the following conditions are met:

- Redistributions of source code must retain the above copyright notice, this list of conditions and the following disclaimer.
- Redistributions in binary form must reproduce the above copyright notice, this list of conditions and the following disclaimer in the documentation and/or other materials provided with the distribution.
- The name of the author may not be used to endorse or promote products derived from this software without specific prior written permission.

THIS SOFTWARE IS PROVIDED BY THE COPYRIGHT HOLDERS AND CONTRIBUTORS "AS IS" AND ANY EXPRESS OR IMPLIED WARRANTIES, INCLUDING, BUT NOT LIMITED TO, THE IMPLIED WARRANTIES OF MERCHANTABILITY AND FITNESS FOR A PARTICULAR PURPOSE ARE DISCLAIMED. IN NO EVENT SHALL THE COPYRIGHT OWNER OR CONTRIBUTORS BE LIABLE FOR ANY DIRECT, INDIRECT, INCIDENTAL, SPECIAL, EXEMPLARY, OR CONSEQUENTIAL DAMAGES (INCLUDING, BUT NOT LIMITED TO, PROCUREMENT OF SUBSTITUTE GOODS OR SERVICES; LOSS OF USE, DATA, OR PROFITS; OR BUSINESS INTERRUPTION) HOWEVER CAUSED AND ON ANY THEORY OF LIABILITY, WHETHER IN CONTRACT, STRICT LIABILITY, OR TORT (INCLUDING NEGLIGENCE OR OTHERWISE) ARISING IN ANY WAY OUT OF THE USE OF THIS SOFTWARE, EVEN IF ADVISED OF THE POSSIBILITY OF SUCH DAMAGE.

OpenSSL License

Copyright (c) 1998-2007 The OpenSSL Project. All rights reserved.

Redistribution and use in source and binary forms, with or without modification, are permitted provided that the following conditions are met:

1. Redistributions of source code must retain the above copyright notice, this list of conditions and the following disclaimer.
2. Redistributions in binary form must reproduce the above copyright notice, this list of conditions and the following disclaimer in the documentation and/or other materials provided with the distribution.
3. All advertising materials mentioning features or use of this software must display the following acknowledgment:
4. "This product includes software developed by the OpenSSL Project for use in the OpenSSL Toolkit. (<http://www.openssl.org/>)"
5. The names "OpenSSL Toolkit" and "OpenSSL Project" must not be used to endorse or promote products derived from this software without prior written

permission. For written permission, please contact openssl-core@openssl.org.

6. Products derived from this software may not be called “OpenSSL” nor may “OpenSSL” appear in their names without prior written permission of the OpenSSL Project.
7. Redistributions of any form whatsoever must retain the following acknowledgment:
“This product includes software developed by the OpenSSL Project for use in the OpenSSL Toolkit (<http://www.openssl.org/>)”

THIS SOFTWARE IS PROVIDED BY THE OpenSSL PROJECT “AS IS” AND ANY EXPRESSED OR IMPLIED WARRANTIES, INCLUDING, BUT NOT LIMITED TO, THE IMPLIED WARRANTIES OF MERCHANTABILITY AND FITNESS FOR A PARTICULAR PURPOSE ARE DISCLAIMED. IN NO EVENT SHALL THE OpenSSL PROJECT OR ITS CONTRIBUTORS BE LIABLE FOR ANY DIRECT, INDIRECT, INCIDENTAL, SPECIAL, EXEMPLARY, OR CONSEQUENTIAL DAMAGES (INCLUDING, BUT NOT LIMITED TO, PROCUREMENT OF SUBSTITUTE GOODS OR SERVICES; LOSS OF USE, DATA, OR PROFITS; OR BUSINESS INTERRUPTION) HOWEVER CAUSED AND ON ANY THEORY OF LIABILITY, WHETHER IN CONTRACT, STRICT LIABILITY, OR TORT (INCLUDING NEGLIGENCE OR OTHERWISE) ARISING IN ANY WAY OUT OF THE USE OF THIS SOFTWARE, EVEN IF ADVISED OF THE POSSIBILITY OF SUCH DAMAGE.

This product includes cryptographic software written by Eric Young (ey@cryptsoft.com). This product includes software written by Tim Hudson (tjh@cryptsoft.com).

Original SSLeay License

Copyright (C) 1995-1998 Eric Young (ey@cryptsoft.com)

All rights reserved.

This package is an SSL implementation written by Eric Young (ey@cryptsoft.com).

The implementation was written so as to conform with Netscape's SSL.

This library is free for commercial and non-commercial use as long as the following conditions are adhered to. The following conditions apply to all code found in this distribution, be it the RC4, RSA, lhash, DES, etc., code; not just the SSL code. The SSL documentation included with this distribution is covered by the same copyright terms except that the holder is Tim Hudson (tjh@cryptsoft.com).

Copyright remains Eric Young's, and as such any Copyright notices in the code are not to be removed. If this package is used in a product, Eric Young should be given attribution as the author of the parts of the library used. This can be in the form of a textual message at program startup or in documentation (online or textual) provided with the package.

Redistribution and use in source and binary forms, with or without modification, are permitted provided that the following conditions are met:

1. Redistributions of source code must retain the copyright notice, this list of conditions and the following disclaimer.
2. Redistributions in binary form must reproduce the above copyright notice, this list of conditions and the following disclaimer in the documentation and/or other materials provided with the distribution.
3. All advertising materials mentioning features or use of this software must display the following acknowledgement:
 “This product includes cryptographic software written by Eric Young (eay@cryptsoft.com)”
 The word ‘cryptographic’ can be left out if the routines from the library being used are not cryptographic related :-).
4. If you include any Windows specific code (or a derivative thereof) from the apps directory (application code) you must include an acknowledgement:
 “This product includes software written by Tim Hudson (tjh@cryptsoft.com)”

THIS SOFTWARE IS PROVIDED BY ERIC YOUNG “AS IS” AND ANY EXPRESS OR IMPLIED WARRANTIES, INCLUDING, BUT NOT LIMITED TO, THE IMPLIED WARRANTIES OF MERCHANTABILITY AND FITNESS FOR A PARTICULAR PURPOSE ARE DISCLAIMED. IN NO EVENT SHALL THE AUTHOR OR CONTRIBUTORS BE LIABLE FOR ANY DIRECT, INDIRECT, INCIDENTAL, SPECIAL, EXEMPLARY, OR CONSEQUENTIAL DAMAGES (INCLUDING, BUT NOT LIMITED TO, PROCUREMENT OF SUBSTITUTE GOODS OR SERVICES; LOSS OF USE, DATA, OR PROFITS; OR BUSINESS INTERRUPTION) HOWEVER CAUSED AND ON ANY THEORY OF LIABILITY, WHETHER IN CONTRACT, STRICT LIABILITY, OR TORT (INCLUDING NEGLIGENCE OR OTHERWISE) ARISING IN ANY WAY OUT OF THE USE OF THIS SOFTWARE, EVEN IF ADVISED OF THE POSSIBILITY OF SUCH DAMAGE.

The licence and distribution terms for any publically available version or derivative of this code cannot be changed. i.e. this code cannot simply be copied and put under another distribution licence [including the GNU Public Licence.]

PPPD License

Copyright (c) 1984-2000 Carnegie Mellon University. All rights reserved.

Redistribution and use in source and binary forms, with or without modification, are permitted provided that the following conditions are met:

1. Redistributions of source code must retain the above copyright notice, this list of conditions and the following disclaimer.
2. Redistributions in binary form must reproduce the above copyright notice, this list of conditions and the following disclaimer in the documentation and/or other materials provided with the distribution.
3. The name “Carnegie Mellon University” must not be used to endorse or promote products derived from this software without prior written permission. For permission or any legal details, please contact
 Office of Technology Transfer
 Carnegie Mellon University
 5000 Forbes Avenue

Pittsburgh, PA 15213-3890
(412) 268-4387, fax: (412) 268-7395
tech-transfer@andrew.cmu.edu

4. Redistributions of any form whatsoever must retain the following acknowledgment:

“This product includes software developed by Computing Services at Carnegie Mellon University (<http://www.cmu.edu/computing/>).”

CARNEGIE MELLON UNIVERSITY DISCLAIMS ALL WARRANTIES WITH REGARD TO THIS SOFTWARE, INCLUDING ALL IMPLIED WARRANTIES OF MERCHANTABILITY AND FITNESS, IN NO EVENT SHALL CARNEGIE MELLON UNIVERSITY BE LIABLE FOR ANY SPECIAL, INDIRECT OR CONSEQUENTIAL DAMAGES OR ANY DAMAGES WHATSOEVER RESULTING FROM LOSS OF USE, DATA OR PROFITS, WHETHER IN AN ACTION OF CONTRACT, NEGLIGENCE OR OTHER TORTIOUS ACTION, ARISING OUT OF OR IN CONNECTION WITH THE USE OR PERFORMANCE OF THIS SOFTWARE.

Copyright (c) 1999-2004 Paul Mackerras. All rights reserved.

Redistribution and use in source and binary forms, with or without modification, are permitted provided that the following conditions are met:

1. Redistributions of source code must retain the above copyright notice, this list of conditions and the following disclaimer.
2. The name(s) of the authors of this software must not be used to endorse or promote products derived from this software without prior written permission.
3. Redistributions of any form whatsoever must retain the following acknowledgment:

“This product includes software developed by Paul Mackerras <paulus@samba.org>”.

THE AUTHORS OF THIS SOFTWARE DISCLAIM ALL WARRANTIES WITH REGARD TO THIS SOFTWARE, INCLUDING ALL IMPLIED WARRANTIES OF MERCHANTABILITY AND FITNESS, IN NO EVENT SHALL THE AUTHORS BE LIABLE FOR ANY SPECIAL, INDIRECT OR CONSEQUENTIAL DAMAGES OR ANY DAMAGES WHATSOEVER RESULTING FROM LOSS OF USE, DATA OR PROFITS, WHETHER IN AN ACTION OF CONTRACT, NEGLIGENCE OR OTHER TORTIOUS ACTION, ARISING OUT OF OR IN CONNECTION WITH THE USE OR PERFORMANCE OF THIS SOFTWARE.

PPPStats License

Copyright (c) 1989 Regents of the University of California.

All rights reserved.

Redistribution and use in source and binary forms are permitted provided that the above copyright notice and this paragraph are duplicated in all such forms and that any documentation, advertising materials, and other materials related to such distribution and use acknowledge that the software was developed by the University of California, Berkeley. The name of the University may not be used to endorse or promote products derived from this software without specific prior written permission.

THIS SOFTWARE IS PROVIDED "AS IS" AND WITHOUT ANY EXPRESS OR IMPLIED WARRANTIES, INCLUDING, WITHOUT LIMITATION, THE IMPLIED WARRANTIES OF MERCHANTABILITY AND FITNESS FOR A PARTICULAR PURPOSE.

PPPDump License

Copyright (c) 1999 Paul Mackerras. All rights reserved.

Redistribution and use in source and binary forms, with or without modification, are permitted provided that the following conditions are met:

1. Redistributions of source code must retain the above copyright notice, this list of conditions and the following disclaimer.
2. Redistributions in binary form must reproduce the above copyright notice, this list of conditions and the following disclaimer in the documentation and/or other materials provided with the distribution.
3. The name(s) of the authors of this software must not be used to endorse or promote products derived from this software without prior written permission.
4. Redistributions of any form whatsoever must retain the following acknowledgment:

"This product includes software developed by Paul Mackerras
<Paulus@samba.org>".

THE AUTHORS OF THIS SOFTWARE DISCLAIM ALL WARRANTIES WITH REGARD TO THIS SOFTWARE, INCLUDING ALL IMPLIED WARRANTIES OF MERCHANTABILITY AND FITNESS, IN NO EVENT SHALL THE AUTHORS BE LIABLE FOR ANY SPECIAL, INDIRECT OR CONSEQUENTIAL DAMAGES OR ANY DAMAGES WHATSOEVER RESULTING FROM LOSS OF USE, DATA OR PROFITS, WHETHER IN AN ACTION OF CONTRACT, NEGLIGENCE OR OTHER TORTIOUS ACTION, ARISING OUT OF OR IN CONNECTION WITH THE USE OR PERFORMANCE OF THIS SOFTWARE.

SSH2 License

Copyright (c) 2004-2007 Sara Golemon <Sarag@libssh2.org>

Copyright (C) 2006-2007 The Written Word, Inc.

All rights reserved.

Redistribution and use in source and binary forms, with or without modification, are permitted provided that the following conditions are met:

Redistributions of source code must retain the above copyright notice, this list of conditions and the following disclaimer.

Redistributions in binary form must reproduce the above copyright notice, this list of conditions and the following disclaimer in the documentation and/or other materials provided with the distribution.

Neither the name of the copyright holder nor the names of any other contributors may be used to endorse or promote products derived from this software without specific prior written permission.

THIS SOFTWARE IS PROVIDED BY THE COPYRIGHT HOLDERS AND CONTRIBUTORS "AS IS" AND ANY EXPRESS OR IMPLIED WARRANTIES, INCLUDING, BUT NOT LIMITED TO, THE IMPLIED WARRANTIES OF MERCHANTABILITY AND FITNESS FOR A PARTICULAR PURPOSE ARE DISCLAIMED. IN NO EVENT SHALL THE COPYRIGHT OWNER OR CONTRIBUTORS BE LIABLE FOR ANY DIRECT, INDIRECT, INCIDENTAL, SPECIAL, EXEMPLARY, OR CONSEQUENTIAL DAMAGES (INCLUDING, BUT NOT LIMITED TO, PROCUREMENT OF SUBSTITUTE GOODS OR SERVICES; LOSS OF USE, DATA, OR PROFITS; OR BUSINESS INTERRUPTION) HOWEVER CAUSED AND ON ANY THEORY OF LIABILITY, WHETHER IN CONTRACT, STRICT LIABILITY, OR TORT (INCLUDING NEGLIGENCE OR OTHERWISE) ARISING IN ANY WAY OUT OF THE USE OF THIS SOFTWARE, EVEN IF ADVISED OF THE POSSIBILITY OF SUCH DAMAGE.

UUID License

Copyright (c) 2004-2008 Ralf S. Engelschall <rse@engelschall.com>

Copyright (c) 2004-2008 The OSSP Project <<http://www.ossproject.org/>>

This file is part of OSSP uuid, a library for the generation of UUIDs which can be found at <http://www.ossproject.org/pkg/lib/uuid/>

Permission to use, copy, modify, and distribute this software for any purpose with or without fee is hereby granted, provided that the above copyright notice and this permission notice appear in all copies.

THIS SOFTWARE IS PROVIDED "AS IS" AND ANY EXPRESSED OR IMPLIED WARRANTIES, INCLUDING, BUT NOT LIMITED TO, THE IMPLIED WARRANTIES OF MERCHANTABILITY AND FITNESS FOR A PARTICULAR PURPOSE ARE DISCLAIMED.

IN NO EVENT SHALL THE AUTHORS AND COPYRIGHT HOLDERS AND THEIR CONTRIBUTORS BE LIABLE FOR ANY DIRECT, INDIRECT, INCIDENTAL, SPECIAL, EXEMPLARY, OR CONSEQUENTIAL DAMAGES (INCLUDING, BUT NOT LIMITED TO, PROCUREMENT OF SUBSTITUTE GOODS OR SERVICES; LOSS OF USE, DATA, OR PROFITS; OR BUSINESS INTERRUPTION) HOWEVER CAUSED AND ON ANY THEORY OF LIABILITY, WHETHER IN CONTRACT, STRICT LIABILITY, OR TORT (INCLUDING NEGLIGENCE OR OTHERWISE) ARISING IN ANY WAY OUT OF THE USE OF THIS SOFTWARE, EVEN IF ADVISED OF THE POSSIBILITY OF SUCH DAMAGE.

Zlib License

Copyright (C) 1995-2010 Jean-loup Gailly and Mark Adler

This software is provided 'as-is', without any express or implied warranty. In no event will the authors be held liable for any damages arising from the use of this software.

Permission is granted to anyone to use this software for any purpose, including commercial applications, and to alter it and redistribute it freely, subject to the following restrictions:

1. The origin of this software must not be misrepresented; you must not claim that you wrote the original software. If you use this software in a product, an

acknowledgment in the product documentation would be appreciated but is not required.

2. Altered source versions must be plainly marked as such, and must not be misrepresented as being the original software.
3. This notice may not be removed or altered from any source distribution.

Jean-loup Gailly

Mark Adler

Copyright

© 2010 Sierra Wireless. All rights reserved.

Trademarks

AirCard and “Heart of the Wireless Machine” are registered trademarks of Sierra Wireless. AirPrime, AirLink, AirVantage, Sierra Wireless, the Sierra Wireless logo, TRU-Install, and the red wave design are trademarks of Sierra Wireless.

Windows® and Windows Vista® are registered trademarks of Microsoft Corporation.

Macintosh and Mac OS are trademarks of Apple Inc., registered in the U.S. and other countries.

QUALCOMM® is a registered trademark of QUALCOMM Incorporated. Used under license.

Linux® is the registered trademark of Linus Torvalds in the U.S. and other countries.

Wi-Fi, WPA, and WPA2 are registered marks of the Wi-Fi Alliance.

QUALCOMM® is a registered trademark of QUALCOMM Incorporated.

Other trademarks are the property of their respective owners.

Contact Information

Sales Desk:	Phone:	1-604-232-1488
	Hours:	8:00 AM to 5:00 PM Pacific Time
	E-mail:	sales@sierrawireless.com
Post:	Sierra Wireless 13811 Wireless Way Richmond, BC Canada V6V 3A4	
Fax:	1-604-231-1109	
Web:	www.sierrawireless.com	

Additional Information and Updates

For up-to-date product descriptions, documentation, application notes, firmware upgrades, troubleshooting tips, and press releases, visit www.sierrawireless.com.

Revision History

Revision number	Release date	Changes
1.0	Apr 10	Initial release



Contents

Device Basics	25
Your Device	25
Components of your device	26
3G and 4G Networks	26
Package Contents	27
Care and Maintenance	27
About This Guide	27
Getting Started With Your Device	28
System Requirements	28
Your Device	29
Battery	29
Installing the Battery	29
Connecting Through USB	30
Charging the Device	31
Using the AC Charger with USB Port	32
Charging Through a Computer	32
Power Button	33
Turning Your Device On	33
Turning Your Device Off	33
Using the Power Button to Determine the Device State	34
Controlling the Device Using the Power Button	34
LCD	35
Interpreting the LCD	35
Mute Switch	36
microSD Card Slot	36
Installing and Setting Up the Device	37
Setting Up the Device	37
Connecting to the Network	37
Changing the Password and Settings	38

Activating and Using Your Network Service	40
Using Your Device	43
Connecting Through USB	43
TRU-Install	43
Requirements for a USB Tethered Connection	43
Making a Tethered Connection	43
Browser Interface Home Page.	44
Displaying the Home Page of the Device	46
Logging On as an Administrator	46
Virtual Device	47
Mini Window	47
Turning Your Device Off	48
Alerts	48
Displaying Alerts	48
3G Activation Required	48
3G Network Update Available	49
SD Card Error	49
Software Update Available	50
Your Network Connection	51
Launching Your Network Connection	51
Sharing Your Connection	51
Ending Your Network Connection	51
Vertical Row (of Icons and Text)	52
Signal Information	53
Mobile Broadband Information and Settings	53
Alert Information	54
Wi-Fi Users Information and Settings	55
Battery Information and Settings	55
Internet Connection Information	57
microSD Card Information and Settings	57
Sounds Information and Settings	58
Home Page Buttons.	59
Buttons Along the Top of the Home Page	59

Buttons Below the Virtual Device	60
Using the microSD Card.	60
Before Using the microSD Card Slot	60
Inserting a microSD Card	62
Removing a microSD Card	62
Accessing the microSD Card	63
Updates	64
Automatically Checking for Updates	64
Manually Checking for Updates	65
Upgrade Firmware From a File	65
Viewing Device Information	66
Reset Button.	68
Restarting the Device.	68
Settings	71
Power Settings	71
Battery and USB Power Settings	71
AC Power Settings	71
Configuring the LCD.	71
Turning the LCD On or Off	71
Setting the LCD Timeout	72
Setting the LCD Brightness	72
Enabling and Disabling the LED.	72
Sounds.	73
Enabling and Disabling Sounds	73
Enabling and Disabling Sounds for Specific Events	73
Low Battery Alert	74
Critical Battery Level Alert	74
Login Settings.	75
Changing the Administrator Password	75
Automatic Login ("Remember Me")	75
Advanced Settings	76
Accessing the Advanced Settings Window	76

Device Tab	76
WAN Tab	80
Wi-Fi Tab	82
Configuring the Wi-Fi Network	84
SSID (Wi-Fi Network Name)	84
Wi-Fi Security	86
Host Name (Device Name)	90
Setting the Maximum Number of Wi-Fi Users	90
Wi-Fi Channel	91
Disabling Wi-Fi When Connected Through USB	91
Configuring 3G/4G	91
Viewing 3G Activation Information	91
3G Panel	92
Resetting the 3G/4G Configuration to Default Settings	92
Configuring the Router Tab	93
Basic Panel	93
LAN Panel	94
Port Forward Panel	98
Port Trigger Panel	100
DMZ Panel	102
Resetting the Software to Default Settings	103
Exporting and Importing Settings	105
Exporting Settings	105
Importing Settings	105
Logs	105
Logs Available	105
Connection History	106
System Events	106
Setting the Method Used for Time Acquisition	107
Setup Pages	108
Welcome to Your Device Window - Select an Option	108
Resources	109
More Information	109

Visiting the CLEAR Website	109
Contacting Customer Service	109
Online Help	109
Frequently Asked Questions	110
How Can I Tell I'm Connected to 3G/4G?	110
How Do I Connect to Wi-Fi?	110
What Do I Do if I Forgot the Wi-Fi Password?	110
What Do I Do if I Forgot the Administrator Password?	111
How Do I Access My Corporate Network Through a VPN?	111
Are Terminal Sessions Supported?	111
Tips	111
Extending Battery Life	111
Device Location	112
Improving Signal Strength	112
Improving 3G Network Service	112
Improving Wi-Fi Performance	113
Security Tips	114
Finding the MAC Address	114
Finding the IP Address	115
Troubleshooting Tips	116
General tips	116
LCD Is Dark	116
Insufficient Signal Strength	116
Messages Displayed on the Device LCD	117
Cannot Connect to Wi-Fi	118
Cannot Display the Home Page	119
Cannot Connect to the 3G/4G Network	120
Cannot Check for Updates	120
Sounds are Enabled, but the Device Doesn't Generate Any Sounds ..	120

Technical Specifications, Safety Information, and Regulatory Information	121
Technical Specifications	121
LED Operation	121
Radio Frequency and Electrical Specifications	121
Software Specifications	122
Environmental Specifications	123
Mechanical Specifications	123
Safety Information	123
Regulatory Notices	124
Index	125

>> 1: Device Basics

Your Clear Spot 4G+ personal hotspot allows you to easily connect to the Internet and to share your 3G/4G connection with others.

This user guide describes how to set up your device and use the browser interface to:

- View the status of your device.
- View and change the settings of your device and the browser interface.

It also describes your device (its various connectors and buttons).

Your Device

The Clear Spot 4G+ personal hotspot provides a simple way to use your 3G/4G Internet connection with any Wi-Fi-enabled device, and to share your Internet connection with friends and family.



Components of your device

Your device consists of these main components:

- **Wi-Fi access point**
The Wi-Fi access point connects your computers and other Wi-Fi-enabled devices to your device.
- **3G modem**
The 3G modem connects your device to the Internet via the 3G (CDMA 1X/EVDO) network (more widely available, compared to 4G).
- **4G modem**
The 4G modem connects your device to the Internet via the 4G (WiMAX) network (newer technology and faster speeds, compared to 3G).
- **Routing hardware**
The routing hardware handles traffic between the 3G/4G modems, the Wi-Fi access point, and the Wi-Fi network.

3G and 4G Networks

These wireless networks connect you to the Internet. Depending on your coverage area, you may have:

- Both 3G and 4G coverage
- Only 3G coverage
- Only 4G coverage.

Your device automatically connects to the fastest network that is available to you. If you have both 3G and 4G coverage and your connection happens to get disrupted, your device can automatically switch to the other network. For more information, see "[Configuring the 3G/4G Connection Preferences](#)" on page 54.

Download speeds

Actual speeds depend on several factors, including network conditions.

Wireless mode	Maximum downlink speeds	Typical downlink speeds
3G (EV-DO Rev 0)	2.4 Mbps	400-700 kbps
3G (EV-DO Rev A)	3 Mbps	0.6-1.4 Mbps
4G	10 Mbps	3-6 Mbps

Package Contents

Your package includes:

- Clear Spot 4G+ personal hotspot by Sierra Wireless
- Battery compartment cover
- Rechargeable battery
- Power adapter
- USB cable
- Quick Start guide

Care and Maintenance

As with any electronic device, you should handle this device with care to ensure reliable operation. Follow these guidelines in using and storing the device:

- Protect the device from liquids, dust, and excessive heat.
- Do not handle or operate the device while driving or operating a vehicle. Doing so may distract you from properly operating the vehicle. In some jurisdictions, operating communication devices while in control of a vehicle is a criminal offense.
- Do not apply adhesive labels to the device. They may cause the device to overheat and may alter the antenna's performance.

About This Guide

This user guide provides you with all the information you'll need to install and use your Clear Spot 4G+ personal hotspot.

The printed Quick Start guide that comes with the Clear Spot 4G+ personal hotspot should be sufficient for most installations.

- Chapter 1 (which you are reading) gives you an overview of the device.
- Chapter 2 describes the buttons, connectors, and other components of the device. (See "[Your Device](#)" on page 29).
- Chapter 3 provides step-by-step instructions for setting up the device. (See "[Installing and Setting Up the Device](#)" on page 37).
- Chapter 4 describes common tasks for your device. (See "[Using Your Device](#)" on page 43).
- Chapter 5 describes advanced configuration of the device and the browser interface. (See "[Settings](#)" on page 71).
- Chapter 6 contains frequently asked questions, troubleshooting tips, and resources for getting help. (See "[Resources](#)" on page 109).
- Chapter 7 lists the electrical, radio frequency, and other parameters of the device for those who require technical information, as well as safety information and regulatory information. (See "[Technical Specifications, Safety Information, and Regulatory Information](#)" on page 121).

Getting Started With Your Device

System Requirements

- One or more computers that support Wi-Fi (802.11b/g)
- Web browser (required if you'll be using the browser interface to view status and to configure settings). The following browsers are supported:
 - Internet Explorer (version 6.0 or higher)
 - Mozilla Firefox (version 2.0 or higher)
 - Google Chrome (version 2.0.172.28 or higher)
 - Apple Safari (version 2.0 or higher)
 - Opera version 9.64
- If you'll be connecting the device through USB:
 - Computer running Windows 7, Windows Vista, Windows XP, or Mac (OS X 10.4.x or higher)
 - USB 2.0 slot

2: Your Device

2

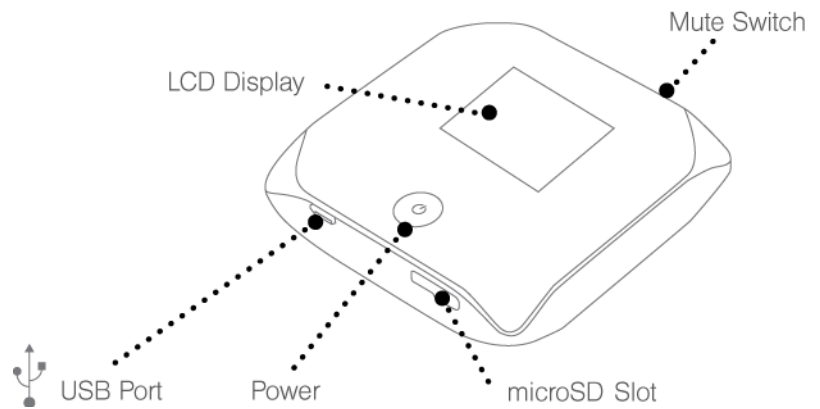

Battery

The battery compartment is on the back of the device. The battery is replaceable.

If you need a new battery, visit the Sierra Wireless online store at <https://www.sierrawireless.com/eStore/>.

Installing the Battery

1. Remove the battery compartment cover.

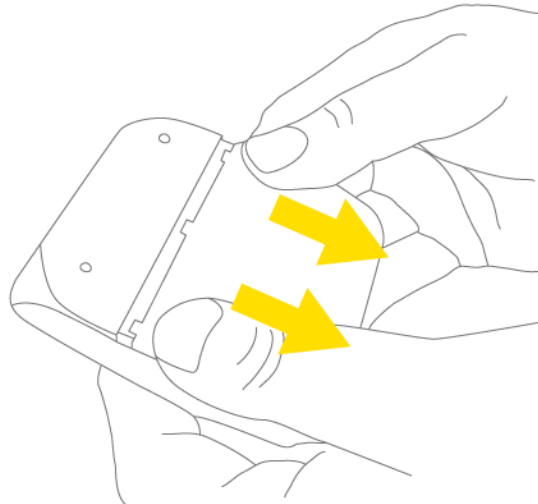

2. Align the battery contact points with those inside the battery compartment, and insert the battery into the device.

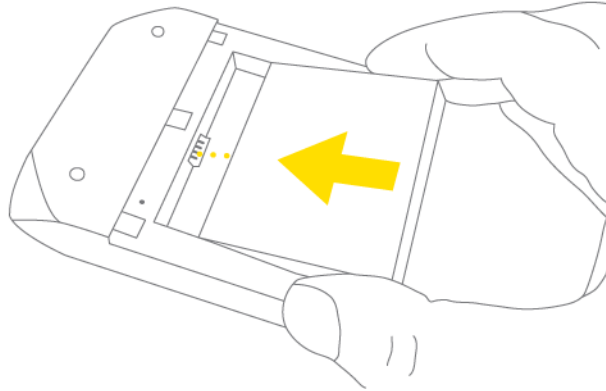

3. Replace the battery compartment cover.

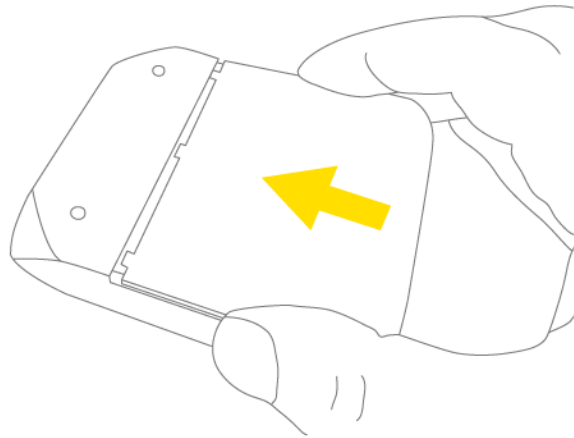

Connecting Through USB

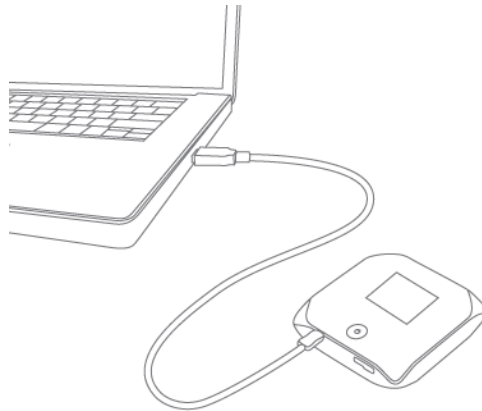

Note: If you'll be using USB for data transfer (and not just for charging the device), you must install the device driver. See ["Making a Tethered Connection"](#) on page 43.

Use the USB cable to connect the device to your computer when:

- You want to charge the device, but you don't want to use the power adapter, or the power adapter is not available.
- Your computer does not have Wi-Fi.
- You want to block others from using the device. (See ["Disabling Wi-Fi When Connected Through USB" on page 91.](#))

To connect the device to your computer:

1. Insert the larger (USB) end of the USB cable into the computer.
2. Insert the other (Micro B) end of the USB cable into the USB connector on the side of the device.

Charging the Device

You need to recharge your device's battery periodically. You can continue using your device while it is charging.

To charge the battery, you have two options, as shown in the drawing that follows — you can connect the device to an AC charger (faster way to charge). See ["Using the AC Charger with USB Port" on page 32.](#) Alternatively, you can connect the device to a computer (slower way to charge). See ["Charging Through a Computer" on page 32.](#)

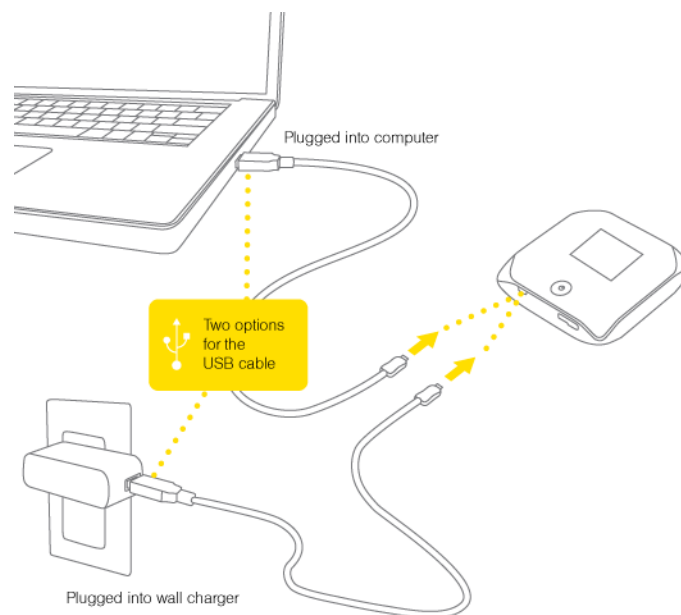

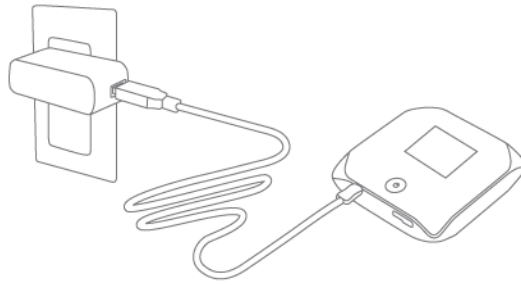

Using the AC Charger with USB Port



1. Insert the smaller (Micro B) end of the USB cable into the USB connector on the side of the device.
2. Insert the other (USB) end of the USB cable into the power adapter.
3. Insert the power adapter into an electrical outlet.

When charging, the LCD shows  and, if the device is off, displays a message "Charging... xx% complete".

When the device is charged, the LCD shows:

-  (if the device is on)
-  and the message "Fully charged" (if the device is off).

Charging Through a Computer

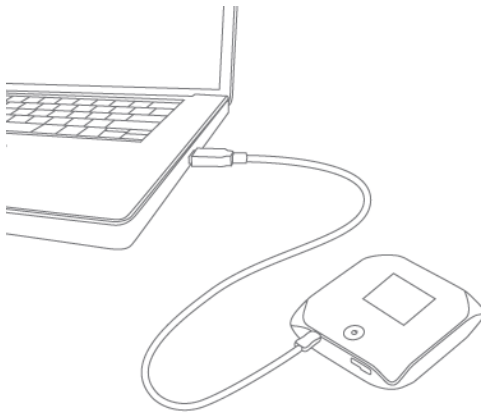

Note: Charging through a computer usually takes longer than charging through the power adapter.

Note: If you'll be using USB for data transfer (and not just for charging the device), you must install the device driver. See "[Making a Tethered Connection](#)" on page 43.

Note: If you're using Mac OS X 10.4.x, after you connect the device you may see a warning message that your computer is running on UPS backup battery and that you should perform a computer shutdown. You can continue with your work. To prevent this message from being displayed, install the device driver. See "[Making a Tethered Connection](#)" on page 43.

1. Ensure the computer is turned on.
2. Insert the larger (USB) end of the USB cable into the computer.
3. Insert the other (Micro B) end of the USB cable into the USB connector on the side of the device.

When charging, the LCD shows .

When the device is charged, the LCD shows .

Power Button

Turning Your Device On

1. Ensure that:
 - The device has a charged battery inserted.
 - or —
 - The device is connected to the power adapter or a computer (through the USB cable), as shown in the drawing on [page 31](#).
2. If the device LCD is blank, press and hold the power button  for two seconds.

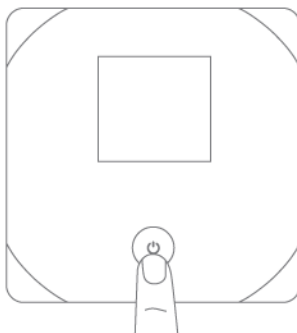



Turning Your Device Off

- Press and hold the power button  for 2 seconds.

Using the Power Button to Determine the Device State

The power button  on the device also indicates the device's status, as shown in the following table.

Power button 	Description	Your action
Not lit	<ul style="list-style-type: none"> The device is turned off, and may or may not be charging. The device is turned on, but you have turned off the LED. 	<ul style="list-style-type: none"> To turn the device on, press and hold the power button  for two seconds. [OPTIONAL]: Turn on the LED. See "Enabling and Disabling the LED" on page 72.
Lit, flashing (approximately every 4 seconds)	The device is turned on, and the LED is enabled.	No action required.
Lit, flashing (approximately every 30 seconds)	The device is in standby (low power) mode. The following are off: LCD, Wi-Fi radio, 3G/4G radios. For more information, see "Standby (Low Power) Mode" on page 56.	To exit standby mode: Connect the device to the power adapter or computer, through the USB cable. — or — Press the power button  .

Controlling the Device Using the Power Button

Type of press	Result
Quick press	<ul style="list-style-type: none"> The device leaves standby (low power) mode. The LCD wakes up (turns on) if it was enabled but dormant. (The LCD turns dark, after a configurable time of inactivity.) A displayed message is confirmed or acknowledged. Display of the Wi-Fi network name (SSID) and password is turned off.
Quick double-press	<ul style="list-style-type: none"> The LCD wakes up (turns on) if it was enabled but dormant. (The LCD turns dark, after a configurable time of inactivity.) The Wi-Fi network name (SSID) and password are briefly displayed. See "Wi-Fi Password Reminder" on page 88.
Long press (press and hold for two seconds)	The device turns on or off.

LCD

If the LCD is not lit, see ["Turning Your Device On" on page 33](#).

Interpreting the LCD

The LCD shows icons and text that reflect the status of the device and your connection.

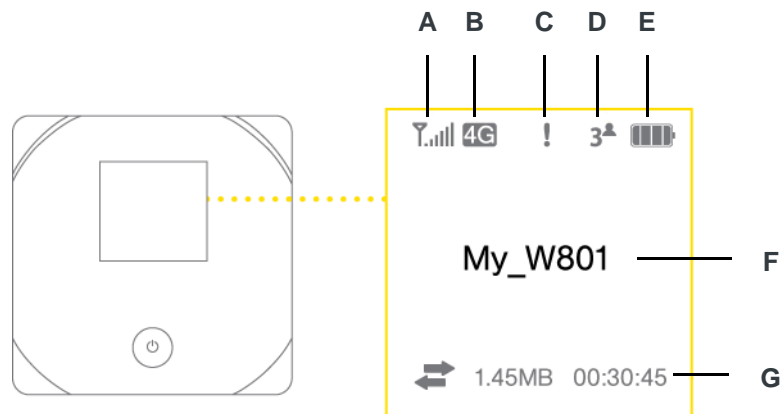

A	Signal strength
B	3G/4G status
C	Alerts
D	Number of Wi-Fi users
E	Battery status
F	Device name. Message area.
G	Amount of data transferred; connection duration. Message area.

Tip: Most of the LCD icons and messages are also shown on the *Virtual Device* (page 47) and *Mini Window* (page 47). See also ["Messages Displayed on the Device LCD" on page 117](#).

Mute Switch

The mute switch is used to turn on or off sounds from the device. The mute switch is located on the side of the device:



Tip: You can also disable sounds through the home page. See "[Sounds Information and Settings](#)" on page 58.

microSD Card Slot

Your device supports a microSD™ card (sold separately) for file sharing and transfer or storage. The microSD slot is located on the same side of the device as the USB connector. Your computer recognizes the microSD card as a removable storage device. The device supports microSD cards up to 16 GB.

Note: Using microSD cards larger than 16 GB can cause data loss and damage your device.

3: Installing and Setting Up the Device

3

Setting Up the Device

1. Install the battery, as described in ["Installing the Battery"](#) on page 29.
2. Connect the device to the AC charger, as described in ["Using the AC Charger with USB Port"](#) on page 32.
3. Plug the AC charger into an electrical outlet.
4. **Important:** Charge the device until the battery icon is full (🔋).

Connecting to the Network

1. Ensure you are in the CLEAR 3G or 4G coverage area.
2. If you have a LAN connection, disconnect it.
3. Ensure your computer's Wi-Fi is turned on.
4. If the device LCD displays "Charging", "Charged", or "Powered off", press and hold the power button  for two seconds.

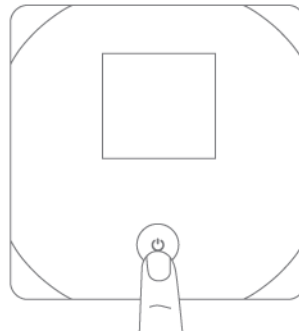

5. Wait until the device LCD displays "Connect your computer to Wi-Fi network," followed by the network name (SSID) and password. This may take several seconds.
6. On your computer, connect to the Wi-Fi network listed on the device LCD. If you don't know how to do this, see ["How Do I Connect to Wi-Fi?"](#) on page 110. After you've connected to the Wi-Fi network, the device LCD displays "Open any web page to continue setup."
7. Open your Web browser. The "Welcome to your Clear Spot 4G+" window opens.

Note: This window displays the administrator password and the address of the device home page. Please remember this information or write it down in a safe place.

This window provides several options.

- To keep the default settings of the device, click one of the following:
 - **The Internet** (to start surfing)
 - **My Clear Spot 4G+'s home page** (to view the device status, customize settings). Proceed to ["Using Your Device" on page 43](#).
- To change security settings, click **Set up my Clear Spot 4G+**.

Changing the Password and Settings

During the device setup, you can select **Set up my Clear Spot 4G+** to change the settings for the:

- **Administrator password**

This password is used to log in to the home page, where you can view and customize your device settings. **The default password is "admin"**. Choose something easy-to-remember (yet not easily guessed by others). If you forget this password, you'll need to reset the device to its default settings and go through the device setup (as described in ["Setting Up the Device" on page 37](#)). Your administrator password must be 1–20 characters long.
- **Wi-Fi network name (SSID)**

This name is visible to other Wi-Fi-enabled devices, and is used to identify your Wi-Fi network. The length of the Wi-Fi network name (SSID) depends on other settings of the browser interface. (See the Help bubble that's displayed when you move the cursor to the SSID input field.)
- **Wi-Fi security**

The default setting is WEP 64 Bit Open. To select another option, click **More options**. See ["Wi-Fi Security Options" on page 39](#).
- **Wi-Fi password**

The maximum length of this field is determined by the Wi-Fi security option (the previous item). (See the Help bubble that's displayed when you move the cursor to the Wi-Fi password field.)
If you'll be sharing your Internet connection with others, you'll have to give the Wi-Fi password to others; don't use your banking or other important passwords. Also, don't use a password that's easily guessed by others.

From this window you can also enable the Password Reminder feature, which is useful if you forget the Wi-Fi password. See ["Wi-Fi Password Reminder" on page 88](#).

Tip: Help information on each field appears (in a bubble) when you move the cursor into the field.

You can display this window any time, by clicking **Admin Setup** () in the browser interface.

After you change the settings and click **Submit**, the device restarts and displays updated information on its LCD. Follow the instructions on the LCD, and proceed to ["Your Device is Now Restarting" on page 40](#).

Wi-Fi Security Options

If you click **More options** (after having clicked **Set up my Clear Spot 4G+**, during the device setup), a window with four Wi-Fi security options opens.

Note: All the devices used with the Clear Spot 4G+ personal hotspot must support the selected security type.

Going from no security to stronger security, the options are:

- **None**
No security (no password is required to access the Wi-Fi network); not recommended. Anyone may access your device and use your Internet connection (you are responsible for payment for data usage).
- **WEP-64 Bit**
Lower security. Works with older and newer Wi-Fi devices. Recommended only if any of your devices don't support WPA or WPA2.
- **WPA-Personal**
A strong security standard, supported by most Wi-Fi devices.
- **WPA2-Personal**
A stronger, newer security standard. Limited to newer Wi-Fi devices.

If the above options don't meet your requirements, click **I don't see what I want...**

Expanded Wi-Fi Security Options

If you display the **Security** panel of the **Wi-Fi** tab of the **Advanced Settings** window or if you click **I don't see what I want...** (from the Wi-Fi Security Options window during the device setup), a window with an expanded list of Wi-Fi security options opens.

Note: All the devices used with the Clear Spot 4G+ personal hotspot must support the selected security type.

The options are:

- **None**
No security (no password is required to access the Wi-Fi network); not recommended. Anyone may access your device and use your Internet connection (you are responsible for payment for data usage).
- **WEP-64 Bit - Shared**
Lower security. Works with older and newer Wi-Fi devices. Recommended only if any of your devices don't support WPA or WPA2.
Shared WEP uses the same key for encryption and authentication; some consider shared WEP to be less secure than open WEP.
- **WEP-128 Bit - Shared**
Lower security. Works with older and newer Wi-Fi devices. Recommended only if any of your devices don't support WPA or WPA2.
Shared WEP uses the same key for encryption and authentication; some consider shared WEP to be less secure than open WEP.
- **WEP-64 Bit - Open**

Lower security. Works with older and newer Wi-Fi devices. Recommended only if any of your devices don't support WPA or WPA2.

Open WEP uses the key for encryption, but not for authentication.

- **WEP-128 Bit - Open**

Lower security. Works with older and newer Wi-Fi devices. Recommended only if any of your devices don't support WPA or WPA2.

Open WEP uses the key for encryption, but not for authentication.

- **WPA-Personal - TKIP**

A strong security standard, supported by most Wi-Fi devices.

- **WPA-Personal - TKIP/AES**

A strong security standard, supported by most Wi-Fi devices.

- **WPA2-Personal - AES**

A stronger, newer security standard. Limited to newer Wi-Fi devices.

- **WPA2-Personal - TKIP/AES**

A stronger, newer security standard. Limited to newer Wi-Fi devices.

- **WPA/WPA2 Personal** (recommended setting)

Wi-Fi devices that use either WPA or WPA2 can connect to the device. Supported by most Wi-Fi devices.

Your Device is Now Restarting

The "Your device is now restarting" window opens if you've clicked the **Set up my Clear Spot 4G+** option and then clicked **Submit**.

The changes take effect after the device restarts automatically.

It's recommended you write down the following information that's displayed in the window:

- Wi-Fi network name
- Wi-Fi password

As described in the window,

1. Wait until the device LCD displays "Connect your computer to Wi-Fi Network".
2. Connect your computer to the Wi-Fi network, using the information you've written down. (If you don't know how to do this, see ["How Do I Connect to Wi-Fi?" on page 110](#)).
3. After the Wi-Fi connection was successfully established, click the **Click here** text in the window.

Activating and Using Your Network Service

Note: If you're able to connect to 3G, you are already set up to use CLEAR service on the 3G network; no further action is needed. Proceed to ["Using Your Device" on page 43](#).

Before using your device, you must have a CLEAR wireless network account set up. The process of setting up an account is called **activation**. When the device starts up, it will detect whether the device has been configured with an account ("preactivated"). If it has not, the activation process starts automatically.

In most cases, the activation process will be seamless, not requiring any action from your part; in some cases, you won't even see any activation-related messages displayed on the device LCD.



Initiating Activation of Your Device for 3G

In rare cases, the device LCD and the home page may indicate that activation is required:

- The LCD displays "3G Activation failed".
- The home page displays the alert "3G Activation Required".

Note: You will still be able to connect to the Internet, when you have 4G coverage.

To activate your device for 3G:

1. In the **Admin Login** section (in the upper left area of the home page), enter the administrator password (1–20 characters/numbers). (The default password is "admin".)
2. Click **OK**.
3. Click the alerts icon  to display the alert window.
4. If more than one alert is available, use the  and  buttons (at the top of the alert window) to browse to the "3G Activation Required" alert.
5. In the alert, click **Activate now**.

If the activation fails, contact CLEAR. See ["Contacting Customer Service" on page 109](#).

Connecting Through USB

TRU-Install

TRU-Install™ is a Sierra Wireless feature that installs the necessary drivers the first time you connect the device to your Windows or Mac computer through the USB cable. (For details, see "[Making a Tethered Connection](#)" below.) An installation CD is not required.

By default, TRU-Install is enabled.

To change the setting:

1. Ensure you're logged in to the home page.
2. Click **Advanced settings > Device > Basic**.
3. Select a value for **TRU-Install**.

Requirements for a USB Tethered Connection

Your device supports a direct connection through a USB cable to a Windows or Mac computer. (This is commonly referred to as a "tethered" connection.)

Making a Tethered Connection

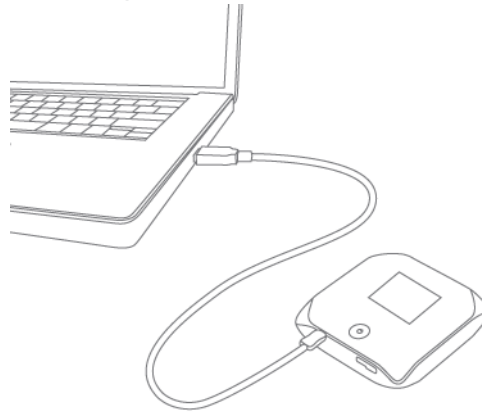

Note: If you'll be using USB for data transfer (and not just for charging the device), you must install the device driver (see below). No installation CD is required — the device supports the Sierra Wireless TRU-Install feature.

Note: If you're using Mac OS X 10.4.x, after you connect the device you may see a warning message that your computer is running on UPS backup battery and that you should perform a computer shutdown. You can continue with your work. To prevent this message from being displayed, install the device driver (see "[Mac](#)", below).

Windows

1. Ensure the device is turned on.
2. Connect the device to your computer through the USB cable.
3. If the TRU-Install window is not displayed, in Windows Explorer browse to the  **TRU-Install** entry (under My Computer), then browse to the Win folder and run **Setup.exe**.
— or —
If you're running Windows Vista and the AutoPlay window opens, click **Run setup.exe**.
4. In the TRU-Install window, click **OK**.
5. Go through the installation of the Sierra Wireless USB driver. (Follow the instructions on the screen.)

Mac

1. Ensure the device is turned on.
2. Connect the device to your computer through the USB cable.
3. In the window that appears, double-click the **.pkg** file.
4. Go through the installation of the Sierra Wireless USB driver. (Follow the instructions on the screen.)
5. When prompted for your password, enter your Mac password.

Connecting the Device to Your Computer

1. Insert the larger (USB) end of the USB cable into your computer.
2. Insert the other (Micro B) end of the USB cable into the USB connector on the side of the device.

Browser Interface Home Page

The home page is the entry page of the browser interface that lets you:

- Display status information for your device and your data connection.
- Launch and end a network connection
- Change the settings for your device and your data connections (if you're logged in).

- Access additional resources (the user guide and the Important Information document).

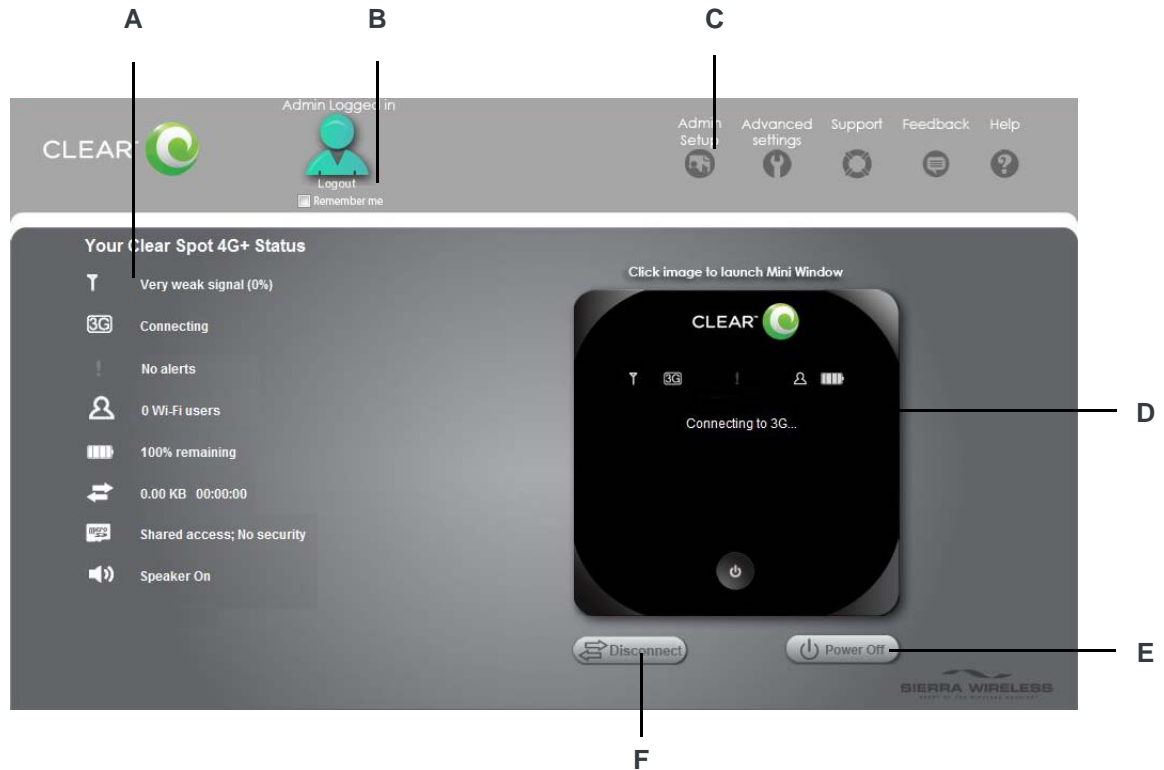

A	When you click an icon or the text next to it, a window opens to the right (see the screenshot on page 52). The window contains additional status information and, if you're logged in, commonly-used configurable settings. See " Vertical Row (of Icons and Text) " on page 52 .
B	Use this area to enter the administrator password and log in. When you're logged in, you can change settings. See " Logging On as an Administrator " on page 46 .
C	Clicking one of these buttons displays a window or a menu. See " Buttons Along the Top of the Home Page " on page 59 .
D	This is the Virtual Device; it reflects the status of your Clear Spot 4G+ personal hotspot. If you click the image, a movable Mini Window is opened. See " Virtual Device " on page 47 and " Mini Window " on page 47 .
E	A handy way to turn the device off, especially if, for example, you're in an airplane before takeoff, and the device is in your overhead bag. Available only if you're logged in.
F	Disconnects a connection, or connects (if currently there's no connection). Available only if you're logged in.

Displaying the Home Page of the Device

Note: You can display the home page only when your device is turned on and you have established a connection to it (through Wi-Fi or through the USB cable).

To display the home page, type one of the following in the address bar of your Web browser:

- **http://clearspot**
 - **SSID** value (field in **Advanced settings > Wi-Fi > Network** and also in **Advanced settings > Router > LAN**).
-

Note: If you're using the Google Chrome Web browser, after typing in the address bar, press the Down Arrow key and then the Enter key. (If you press only the Enter key, a Google search is started, using the information you typed in.)

If your Web browser displays an error message, see ["Cannot Display the Home Page" on page 119](#).

Logging On as an Administrator

You don't need to log in to access and use the home page. However, when you're logged in:

- Additional information appears in the window that appears when you click an item on the left side of the home page. See ["Vertical Row \(of Icons and Text\)" on page 52](#).
- You can access the **Advanced Settings** window, where you can modify additional settings.
- You can rerun the device setup, if required (**Admin Setup** ).
- You can install updates.

To log in:

1. Ensure that nobody else is already logged in — other people can use the home page at the same time, but only one user can be logged in.
2. In the **Admin Login** section (in the upper left area of the home page), enter the administrator password (1–20 characters/numbers). (The default password is "admin". It's recommended you change the password, if you haven't already.)
3. Click **OK**.

After a certain time, you will be automatically logged off (timeout security feature), unless you select **Remember me** (below the password field). For more information, see ["Automatic Login \("Remember Me\)" on page 75](#).

Virtual Device

The right half of the home page contains an image of your device.



This is a "virtual device" — it reflects most of the icons and text displayed on the real device.

Mini Window

If you click the virtual device on the home page, the Mini Window opens — an image of the device in a separate Web browser window.



Similar to the virtual device, the Mini Window reflects most of the icons and text displayed on the real device.

To save space on your monitor, you can close the home page and move the Mini Window to the side of your monitor. Then you can use the window to keep an eye on the status of your device and connection. (To reopen the home page, click the **Home** link.)

If you're logged in, the window has a **Connect** or **Disconnect** button, and a **Power Off** button.

Turning Your Device Off

From the Home page:

1. Ensure you're logged in to the home page.
2. Click **Power Off** (below the Virtual Device).

From the Mini Window:

1. Ensure you're logged in to the home page.
2. Click **Power Off**.

From the device:

1. Press and hold the power button  for 2 seconds.

Note: You can turn the device on only by using the device power button.



Alerts

Displaying Alerts

The alerts icon  indicates whether there are any alerts (messages that require your attention).

The icon is on the left side of the home page.

Click the icon to display the Alert window. If more than one alert is available:

- The higher priority alert opens.
- When you close an alert, the next alert opens.
- You can use the  and  buttons (at the top of the alert window) to view other alerts.



The options and instructions shown in the alert window depend on the alert event. Please read the instructions carefully. They may state, for example, that you have to reconnect to Wi-Fi after an update is installed.

3G Activation Required

If only 3G coverage is available, you won't be able to connect to the Internet until 3G activation has been completed.

To activate 3G on your device:

1. Ensure you have 3G coverage.

2. In the **Admin Login** section (in the upper left area of the home page), enter the administrator password (1–20 characters/numbers). (The default password is "admin".)
3. Click **OK**.
4. Click the alerts icon  to display the alert window.
5. If more than one alert is available, use the  and  buttons (at the top of the alert window) to browse to the "3G Activation Required" alert.
6. In the 3G Activation Required alert window, click **Activate now**. (Activation is then performed over the network; no user interaction is required.)
 - If activation is successful, "Activation complete!" is displayed. You can now connect to the 3G network. If the connection is not established automatically, click **Connect** on the home page or Mini Window.
 - If activation was not successful, "Activation failed" is displayed. Retry the activation. If it is not successful, prepare the following, and contact CLEAR:
 - Your billing information.
 - ESN of the device (displayed on the packaging, on the device [under the battery], and at **Advanced settings > Device > About**).



3G Network Update Available

The 3G Network Update Available alert appears if a PRL update or 3G profile update is available for your device. The update may improve your 3G network service.

Note: During installation of the update:

- **DO NOT** turn off or unplug the device.
 - Your 3G connection won't be available. (Your 4G connection won't be affected.)
-

To install the update:

1. Ensure you have 3G coverage.
2. In the **Admin Login** section (in the upper left area of the home page), enter the administrator password (1–20 characters/numbers). (The default password is "admin".)
3. Click **OK**.
4. Click the alerts icon  to display the alert window.
5. If more than one alert is available, use the  and  buttons (at the top of the alert window) to browse to the "3G Activation Required" alert.
6. In the 3G Network Update Available alert window, click **Update now**.

SD Card Error

If you're having problems reading from the microSD card, or if the SD Card Error alert window opens or the device LCD displays "SD Card error", try the following:

1. Remove and reinsert the microSD card.
2. If the card is still not working, try it in the microSD slot of another computer.

If it works in the other device, the card slot on your Clear Spot 4G+ personal hotspot may have a problem.

If the card doesn't work in the other computer, try one of the following:

- Use a different microSD card.
- Reformat your card.

Note: The formatting procedure erases all the data on the microSD card, after which the files CANNOT be retrieved. To prevent the loss of important data, please check the contents before you format the microSD card.

Software Update Available

The update may improve performance and add or modify features.



Note: During installation of the update, your Internet and Wi-Fi connections won't be available.

When the installation is complete, you will need to reconnect to Wi-Fi.

To install the update:

1. Ensure your device is connected to the power adapter or computer, through the USB cable.

Note: If you'll be using USB for data transfer (and not just for charging the device), you must install the device driver. See ["Making a Tethered Connection"](#) on page 43.

2. In the **Admin Login** section (in the upper left area of the home page), enter the administrator password (1–20 characters/numbers). (The default password is "admin".)
3. Click **OK**.
4. Click the alerts icon  to display the alert window.
5. If more than one alert is available, use the  and  buttons (at the top of the alert window) to browse to the "3G Activation Required" alert.
6. In the Software Update Available alert window, click **Update Options**.
7. Read the information in the Software Installation Options window.
8. To install the updates, click **Download and install now**.
— or —
If you are not in a strong signal area, make a note of the URL displayed in the window and click **I'll get the update later**. At a later time, access the URL to download the update to your computer, and then ["Upgrade Firmware From a File"](#) on page 65.
9. When the installation is complete, reconnect to Wi-Fi. See ["How Do I Connect to Wi-Fi?"](#) on page 110.

Your Network Connection

Launching Your Network Connection

After the device powers on and boots up, a connection to the 3G/4G network is launched automatically, unless you've disabled **Connect Automatically**.

You will need to manually launch a connection if:

- The connection was not successful.
- You've disabled auto-connect.
- You've manually ended a connection (by clicking **Disconnect**).

To launch a connection:

- Click **Connect** on the Virtual Device on the home page (you must be logged in).

— or —

Click **Connect** in the Mini Window (you must be logged in).

— or —

If the device LCD displays "Disconnected from 3G/4G network. Connect now?", press the power button  on the device.

Sharing Your Connection

For others to share your network connection:

1. Provide the Wi-Fi network name and password to them.
2. On their computer, users must connect to the Wi-Fi network of the Clear Spot 4G+ personal hotspot. See ["How Do I Connect to Wi-Fi?" on page 110](#).

Ending Your Network Connection

1. Ensure you're logged in to the home page.
2. Click **Disconnect** on the Virtual Device or in the Mini Window. See ["Virtual Device" on page 47](#) and ["Mini Window" on page 47](#).

Note: The Wi-Fi connection is still available, so users can, for example, share files by using a microSD card.

Vertical Row (of Icons and Text)

The left part of the home page has a vertical row of icons and text, starting with the signal strength indicator .

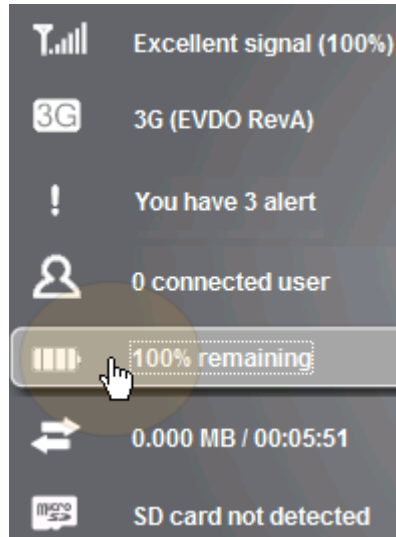

Most of these icons are also shown on the physical device and Virtual Device ([page 47](#)). Hover the mouse over an icon; the corresponding icon on the Virtual Device is highlighted.

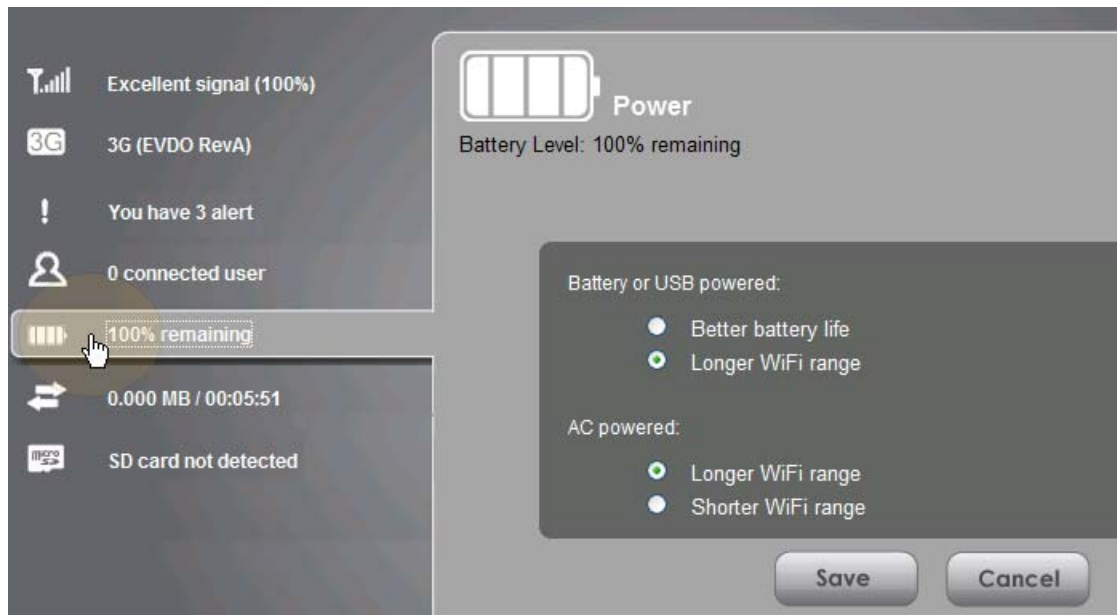

If you click an icon or the text, a window opens with additional information, as shown in the following screenshot.



If you're logged in, the window may also display configurable settings.

Tip: A more complete set of configurable settings is available in the Advanced Settings window. See ["Advanced Settings" on page 59](#).

Signal Information

Icon	Description
	No signal
	Very weak signal
...	The number of bars reflects the signal strength: the more bars, the stronger the signal.
	Excellent signal

Click the icon to display the Signal Quality window. The window displays:

- The active network: the network that is currently being used for your data connection. For example: "3G (EVDO Rev A)".
- 3G or 4G status:
 - Connection status. For example: "Connected".
 - Brief description of the signal strength. For example: "Good signal (60%)".
 - Tables that show the coverage type, RSSI, and Ec/Io (for 3G) or CINR (for 4G).

RSSI reflects the signal strength of the network.

Ec/Io is a dimensionless ratio of the average power of a channel, typically the pilot channel, to the total signal power.



CINR stands for Carrier to Interference-plus-Noise Ratio, and is a measurement of signal effectiveness.

The first table also shows the type(s) of 3G service you have: 1X, 1xEV-DO, or both. (To determine whether you have EV-DO Rev. 0 or Rev. A service, use the text near the 3G icon; see ["Mobile Broadband Information and Settings" on page 53](#).)

See also ["Improving Signal Strength" on page 112](#).

Mobile Broadband Information and Settings

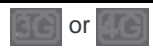
The 3G or 4G icon indicates the service and connection state. Note that only one icon is shown (the active network).

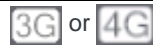
Icon	Description
	You have no service. Try the suggestions in "Cannot Connect to the 3G/4G Network" on page 120 .
	You have service but are not connected.
	You have service and are connected.

The text next to the icon displays the connection status, for example: "No service", or "3G (EVDO Rev A)".

Click the icon or text to display the Mobile Broadband Information window. The window displays:

- The active network: the network that is currently being used for your data connection. For example: "4G" or "3G (EVDO Rev A)".
- 3G and 4G status:
 - Connection status. For example: "Connected".
 - Brief description of the signal strength. For example: "Good signal (60%)".
- Connection Preferences (if you're logged in).

Configuring the 3G/4G Connection Preferences

The value determines which network(s) to connect to, and in what order:

- **4G Preferred** — Connection can be established to either 3G or 4G; if both are available, 4G is used. This setting is recommended if your service provider has no data limit for 4G, but does for 3G, or you want to take advantage of the faster data transfer speeds of 4G.
- **4G Only** — Connection can be established only to 4G.
- **3G Only** — Connection can be established only to 3G.



If you don't have 4G coverage, you can save power by selecting "3G Only".

To automatically connect to the network upon loss of connection or when the device powers on, select **Connect Automatically**.

Alert Information

The alerts icon indicates whether there are any alerts (situations that require your attention).

Note: To view alert information, you must be logged in. New alerts are checked upon device power-up. That is, if an event occurs, you won't be notified until the device is restarted.

Icon	Description
	No alerts are available.
	One or more alert is available.



The text next to the icon indicates the number of alerts.

Click the icon or text to display the Alert window.

For more information, see ["Alerts" on page 48](#).

Wi-Fi Users Information and Settings

The Wi-Fi users icon shows how many Wi-Fi users are connected to the device.



Icon	Description
	No Wi-Fi users are connected. (One user is connected via USB).
	One user is connected via Wi-Fi.
	The number indicates how many Wi-Fi users are connected.

Click the icon to display the Connected Users window.

Connected User Information

When you're logged in, the Connected Users window shows a table with information on computers currently connected to the device.

A row may optionally show one or both of these icons:

-  — The user of this computer is logged in as administrator.
-  — This computer is connected to the device through the USB cable.

MAC Address — Each wireless device has a unique MAC address (assigned by its manufacturer). On a Windows PC, the MAC address is called the "physical address"; on a Mac, it is called the "Ethernet ID". See ["Finding the MAC Address" on page 114](#).

Block — Used to block the computer's access to the device. You might want to do this if:

- You don't recognize a listed computer.
- You have lots of data to transfer (you want to be the sole user of the bandwidth).
- You're approaching the data limit on your account.

Note: You cannot block the administrator. (The row for the administrator has the  icon).

Max Wi-Fi users — Limits the number of Wi-Fi users that can connect to the device. A smaller number improves performance and security.







Disable Wi-Fi when connected via USB — Turns off the Wi-Fi of the device when connected to a computer through the USB cable. Only this computer will be able to use the device.

Battery Information and Settings

The battery icon indicates the state of the battery of the device.

The text next to the icon displays additional information, for example, the charging status (% remaining or % complete).

Tip: You can also check the battery icon from the Home page, Mini Window, and Device LCD.

Icon	Description
	Battery level is critical. Charge the device immediately. See " Charging the Device " on page 31.
	No battery; connected to an electrical outlet (through the power adapter).
	Connected to USB. Battery is either charging, or is not inserted.
	Charging through the power adapter.
	Battery is low. Charge the device. See " Charging the Device " on page 31.
...	The more bars are shown, the more the battery is charged.
	Battery is charged.

Click the icon to display the Battery Information and Settings window.

When you're logged in, you can set the behavior for when the device is:

- **Battery or USB powered.** Choose one of the following:
 - **Better battery life** — At the cost of shorter Wi-Fi range.
 - **Longer Wi-Fi range** — At the cost of shorter battery life.
- **AC powered.** Choose one of the following:
 - **Longer Wi-Fi range**
 - **Shorter Wi-Fi range** — You have a designated wireless area and you need to minimize the effect of your network on other networks in the vicinity.

Standby (Low Power) Mode

When the device is in standby (low power) mode, the 3G/4G modem radios, the Wi-Fi radio, and the LCD are off, and the power button  is flashing.

When you're logged in, you can set how soon the device goes into standby mode when no Wi-Fi users are connected to it (**Standby Timer**).

You can specify settings for battery power and AC power.

Note: This setting has no effect when the device is connected to a computer through the USB cable.

To exit standby mode:

- Connect the device to the power adapter or computer, through the USB cable.
- or —

Press the power button .

Internet Connection Information

Note: Data usage amounts are approximate and should not be used for billing purposes. For accurate data usage amounts, check with CLEAR.

Click the data icon  to display the Internet Connection Information window. The window displays:

- Data statistics for the current connection session:
 - Data sent
 - Data received
 - Total transferred
 - Session duration
- The WWAN IP address of the device — the external IP address of the modem (3G or 4G) — that is, the IP address of the modem as seen from the Internet.

Viewing and Configuring Detailed Internet Connection Information

When you're logged in, the Internet Connection Information window displays a table showing data use:

- In the currently billing cycle. These numbers get automatically reset to 0 on the day selected in the **Starts on day** list.
- Over the lifetime of the device.
- By network (3G/4G), and by sent/received/total.

From this window you can:

- Reset the data usage figures for the current billing cycle. (Click **Reset**.)
- Change the start day of the billing cycle (in the **Starts on day** list).

microSD Card Information and Settings

The text next to the icon indicates whether the card is:

- Enabled
- Detected
- Accessible by all ("shared") or only the administrator
- Accessible with or without a password (security)

Click the icon to display the SD Card Information and Settings window. The window displays:



- The card status (see the above list)
- Storage capacity of the card, and space available

When you're logged in, you can:

- Enable or disable the microSD card slot. See ["Enabling the microSD Card Slot" on page 61](#).
- Set up access to the card. See ["Setting Up Access to the microSD Card" on page 61](#).

Sounds Information and Settings

The sounds icon () shows whether the device speaker is on.

Icon	Description
	The device speaker is on.
	The device speaker is off.

Click the icon to display the Sounds window. The window displays:

- Status of the device speaker (on or off).
- If you're logged in: check boxes to enable or disable sounds for the following events:
 - **Internet connected**
 - **Internet disconnected**
 - **Low battery** — Useful as a reminder to charge the device.
 - **System alerts** — When you hear the device beep, you can then use the device LCD or the Alerts window to get information about the alert. See ["Alert Information" on page 54](#).

Note: System alerts include several types of events, for example:

- *Critical battery*
- *Critical temperature*
- *Software update available*
- *Network update available*
- *Routing hardware settings reset*
- *Device startup failure*

-
- **Wi-Fi user has joined** — Useful, for example, to detect an unwelcome Wi-Fi user if you're the only one using the device.
 - **Wi-Fi user has left**
 - **Last user has left** — When you hear the device beep, you can turn off the device, if nobody will be using it for awhile.

Tip: You can also disable all sounds through the mute switch on the device. See ["Mute Switch" on page 36](#).

If you've enabled the sounds through the home page, but there are no sounds when an event occurs, check the position of the Mute switch.

Home Page Buttons

Buttons Along the Top of the Home Page

The top horizontal part of the home page has the following areas and buttons:

- **Admin Login.** See ["Logging On as an Administrator" on page 46.](#)
- **Admin Setup** — Rerun the device setup, for example, after you've reset the software to default settings. See ["Welcome to Your Device Window - Select an Option" on page 108.](#)
- **Advanced settings.** See ["Advanced Settings" on page 59.](#)
- **Support.** See ["Support Button" on page 59.](#)
- **Feedback** — Send your comments on the device. See ["Feedback" on page 60.](#)
- **Help** — Open the Help system, display the important information booklet, or download the user guide.

Admin Setup Button

This button displays a window where you can change the administrator password, Wi-Fi network name (SSID), Wi-Fi security type, and Wi-Fi password.

For more information, see ["Welcome to Your Device Window - Select an Option" on page 108.](#)

Advanced Settings

From the Advanced Settings window you can configure all the settings of the device and the browser interface.

The Advanced Settings window has the following tabs; each tab has several panels.

- Device tab. See ["Device Tab" on page 76.](#)
- WAN tab. See ["WAN Tab" on page 80.](#)
- Wi-Fi tab. See ["Wi-Fi Tab" on page 82.](#)
- Router tab. See ["Configuring the Router Tab" on page 93.](#)

For help on a tab, click **Help** . For most fields and buttons, contextual (field-level) Help appears to the right of the window, when you move the cursor over the item. For more information, see ["Contextual Help in the Advanced Settings Window" on page 109.](#)

Accessing the Advanced Settings Window

1. Ensure you're logged in to the home page.
2. Click **Advanced settings** .

Support Button

The **Support** button opens, in a new Web browser window (or tab), the online support site for your device.

Note: This button is available only when you're connected to the Internet.

Feedback

The **Feedback** button opens, in a new Web browser window (or tab), the online feedback site for your device.

Note: This button is available only when you're connected to the Internet.

Help Button

This button displays a menu with options to:

- Display the online Help.
- Download the user guide.
- View the important information booklet. This booklet contains warranty and other information.

Buttons Below the Virtual Device

Note: The buttons appear only when you're logged in.

Connect/Disconnect Button

This button disconnects a connection, or connects (if currently there's no connection).

Power Off Button

This button turns the device off.

Note: You can turn the device on by using the device power button.

Using the microSD Card

Before Using the microSD Card Slot

1. Enable the slot. See ["Enabling the microSD Card Slot" on page 61](#).
2. Set up access to the slot. See ["Setting Up Access to the microSD Card" on page 61](#).
3. [OPTIONAL]: Rename the **microSD Shared Folder Name**. See ["microSD Shared Folder Name" on page 61](#).
4. Inform others how they can access the card. See ["Accessing the microSD Card" on page 63](#).

Enabling the microSD Card Slot

Before computers can recognize the microSD card, you must enable the microSD slot on the device.

1. Ensure you're logged in to the home page.
2. In the SD Card Information and Settings window, select **Enable SD Card**. (See ["microSD Card Information and Settings" on page 57.](#))

— or —

From **Advanced settings > Device > microSD card**, in the **SD-Card Slot** section select **Enable**.

Setting Up Access to the microSD Card

If you've enabled access to the microSD card, you must also specify whether a username and password are required to access the card.

1. Ensure you're logged in to the home page.
2. In the SD Card Information and Settings window or from **Advanced settings > Device > microSD card**, under **Username and Password Security**, select one of the values:
 - To have no security, select **None**.
Anyone can use the card; no username or password is required.
 - To allow only the administrator to use the card, select **Administrator Only**.
When prompted for the username (when you try to use the card), enter "admin". For the password, enter the home page login password.
 - To allow non-administrators to use the card, select **Administrator + Guest**.
3. If you've selected **Administrator + Guest**:
 - a. [OPTIONAL]: Change the **Set Guest Username** and **Set Guest Password** fields (up to 20 characters each; spaces are allowed).
 - b. Give the guest username and password to people whom you want to allow access to the card.

microSD Shared Folder Name

You can optionally change the name of the folder that the microSD card shows up as (in the file browser program); the default folder name is "shared".

1. Ensure you're logged in to the home page.
2. Click **Advanced settings > Device > MicroSD card**.
3. In the MicroSD Shared Folder Name field, type the new name.

You can use up to 32 letters, numbers, and spaces in any combination.

For information on how this folder name is used, see ["Accessing the microSD Card" on page 63](#).

Inserting a microSD Card

To insert the microSD card:

1. Gently flip open the tab labelled "microSD" on the side of the device.

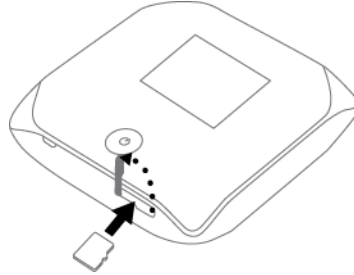

2. Gently insert the microSD card (label facing up) into the slot on the side of the device, until the microSD card clicks into place.

Note: If your microSD card has not been formatted, or is in a format that your computer does not recognize, you may be prompted to format the microSD card. The formatting procedure erases all the data on the microSD card, after which the files CANNOT be retrieved. To prevent the loss of important data, please check the contents before you format the microSD card.

3. Check the status of the microSD card. See ["microSD Card Information and Settings" on page 57](#).

Removing a microSD Card

1. Ensure you and other users have completed any file transfers.
2. Gently flip open the tab labelled "microSD" on the side of the device.

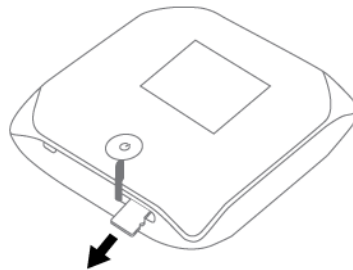

3. Using your fingernail or a thin blunt object, gently press the microSD card in and then release; it should partially pop out of its slot, as shown in the drawing above.
4. Remove the microSD card and store it in a safe place.
5. Close the tab over the microSD slot of the device.

Accessing the microSD Card

If the microSD slot is enabled, an inserted card appears in your file browser as a shared network drive.

The way to access the card varies, depending on your operating system.

Note: In the information that follows, **<Hostname>** is the value of the **Hostname** field (in **Advanced settings > Wi-Fi > Network** and also in **Advanced settings > Router > LAN**).

Windows

1. In Windows Explorer or Internet Explorer, type one of the following:

- `\\clearspot\`
- `\\<Router IP address>\` (field in **Advanced settings > Router > LAN**)

For example: `\\192.168.0.1\`

- `\\<Hostname>\`

For example: `\\MyDeviceName\`

— or —

From the Windows **start** menu, click **start > Run**, and then type one of the following:

- `\\clearspot\`
- `\\<Hostname>\`

2. Double-click the shared folder.

Mac

1. In Finder, select **Go > Connect to Server**.
2. Type one of the following:
 - `smb://clearspot/`
 - `smb://<Router IP address>/`
 - `smb://<Hostname>/`
3. When prompted, select the shared drive as the folder to mount.

Linux

1. Open the run menu (Alt+F2) or a file browser, and type one of the following:
 - `smb://clearspot/`
 - `smb://<Router IP address>/`
 - `smb://<Hostname>/`
2. Double-click the shared folder.

Other operating systems

Please see the user documentation for your operating system or computer.

If security has been enabled for the microSD card, you will be prompted to enter the username and password for the microSD card. (See ["Setting Up Access to the microSD Card" on page 61](#)).

Updates

Note: If a software update, 3G network update, or 3G profile update is available, the device LCD displays a message, and an alert is available from the home page. See ["Software Update Available"](#) on page 50 and ["3G Network Update Available"](#) on page 49.

The update may improve performance and add or modify features. The updates may include the following:

- Device firmware
- 3G network update
- The browser interface
- Help files
- Other files

You can:

- Manually check for updates. See ["Manually Checking for Updates"](#) on page 65.
- Set the browser interface to automatically check for updates. See the next section.

Automatically Checking for Updates

To specify how often the browser interface checks for updates:

1. Log in to the home page.
2. Click **Advanced settings** ().
3. Click **Device > Basic**.
4. In the **Check for Updates** list, click an option.

*Note: If **Check for Updates** is not available, your device supports the Guaranteed Update feature, which automatically checks for updates, at a pre-determined frequency. This feature requires 4G coverage.*

Tip: When updates are available, an alert is shown in the browser interface. See ["Alert Information"](#) on page 54.

Manually Checking for Updates

Note: During installation of the update:

- **DO NOT** turn off or unplug the device.
- Your Wi-Fi and Internet connections won't be available.

When the installation is complete, you will need to reconnect to Wi-Fi. (See "[How Do I Connect to Wi-Fi?](#)" on page 110).

Checking for updates

1. Log in to the home page.
2. Ensure you're connected to 3G/4G.
3. Click **Advanced settings** .
4. Click **Device > Basic**.
5. Click **Check for updates now**. (The message next to the button indicates whether updates are available.)

Installing the updates

If updates are available, after you've manually checked for updates:

1. Ensure your device is connected to the power adapter or computer, through the USB cable.
-

Note: If you'll be using USB for data transfer (and not just for charging the device), you must install the device driver. See "[Making a Tethered Connection](#)" on page 43.

2. Click **Update options**.
3. Read the information in the Software Installation Options window.
4. To install the updates, click **Download and install now**.

— or —

If you are not in a strong signal area, make a note of the URL displayed in the window and click **I'll get the update later**. At a later time, access the URL to download the update to your computer, and then follow the steps in "[Upgrade Firmware From a File](#)" on page 65.

5. When the installation is complete, reconnect to Wi-Fi. See "[How Do I Connect to Wi-Fi?](#)" on page 110.

Upgrade Firmware From a File

Use this option when you have an updated firmware file that you've, for example, downloaded from the CLEAR or Sierra Wireless website.

Note: During installation of the update:

- **DO NOT** turn off or unplug the device.
- Your Wi-Fi and Internet connections won't be available.

When the installation is complete, you will need to reconnect to Wi-Fi. (See "[How Do I Connect to Wi-Fi?](#)" on page 110).

To upgrade the device firmware from a file:

1. Log in to the home page.
2. Ensure **Disable Wi-Fi when connected via USB** is selected. See "[Disabling Wi-Fi When Connected Through USB](#)" on page 91.
3. Ensure your device is connected to the power adapter or computer, through the USB cable.
4. Click **Advanced settings** ().
5. If you want to later confirm that the upgrade was successful, write down the current version information (shown in **Device > About**):
 - Software version
 - Firmware version (in the 3G section)
 - Firmware version (in the 4G section)
6. Click **Device > Basic**.
7. [OPTIONAL]: Save the current configuration (recommended).
 - a. Click **Export**.
 - b. Save the file. Note the filename and path.
8. Click **Browse** next to the **Update Firmware From File** field, and click the firmware file to upload to the device.
9. Click **Update**.

Please wait while the upgrade occurs; this may take several minutes. The device LCD shows the upgrade status. The device will restart (possibly several times).

Once the upgrade is complete, the LCD device shows the usual icons and text (for example, the device name).
10. Compare the current version information (in **Device > About**) to the values you wrote down in step 5 to confirm that the upgrade was successful.
11. If you've saved the current configuration, reload it.
 - a. Click **Browse** next to the **Import Router Settings** field, and click the file you've saved.
 - b. Click **Import**.
12. Reconnect to Wi-Fi. See "[How Do I Connect to Wi-Fi?](#)" on page 110.

Viewing Device Information

1. Log in to the home page.
2. Click **Advanced settings** ().
3. Click **Device > About**.

Note: 4G information is not available if **WAN mode** is "3G only". (**WAN mode** is in **Advanced settings > WAN > Setup**.)

The following information is displayed:

- **Model Number**
- **Manufacturer**
- **Software Version.**
Firmware version for the routing hardware component of the device.
- **Activation Status.**
3G activated, or not activated.
- **Activation Date.**
Date that the 3G modem was first activated.
- **Network Operator.**
The carrier that your device was activated for.
- **Wi-Fi Firmware Version**
- **Router PRI Version.**
PRI version for the routing hardware component of the device. The PRI (Product Release Instructions) is a file that contains the settings used to configure wireless products for a particular service provider, customer, or purpose.
- **ESN or MEID (3G).**
The ESN (Electronic Serial Number) is the unique first-generation serial number assigned to the 3G component of the device.
The MEID (Mobile Equipment Identifier) is the unique second-generation serial number assigned to the 3G component of the device.
- **PRI Version.**
PRI version of the 3G component of the device. The PRI (Product Release Instructions) is a file that contains the settings used to configure wireless products for a particular service provider, customer, or purpose.
- **MSID (Mobile Station ID)**
The MSID is also known as IMSI (International Mobile Station Identity) — an identifier of a device on the 3G network.
- **PRL Version.**
The PRL (Preferred Roaming List) is an account configuration item set by your service provider. It controls the radio channels and network carrier used by the 3G modem. An updated PRL may improve your 3G network service.
- **Firmware Version.**
Firmware version of the 3G component of the device.
- **MAC Address.**
MAC address of the 4G module. Each wireless device has a unique MAC address (assigned by its manufacturer).
- **Firmware Version.**
Firmware version of the 4G component of the device.

The window also has buttons to:

- Save the information to a text file.
- Reset the 3G/4G configuration of the device to default settings. See ["Resetting the 3G/4G Configuration to Default Settings" on page 92.](#)

Reset Button

The reset button is inside the hole located below and to the right of the battery compartment as shown below.

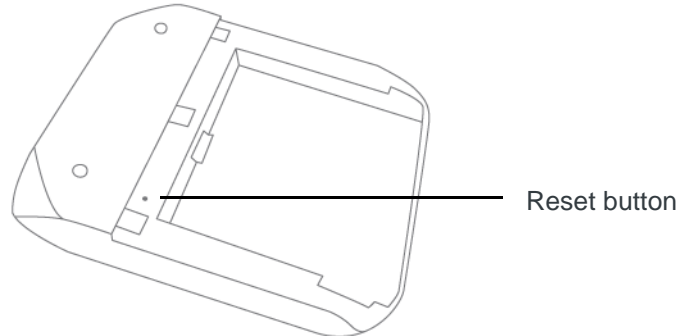

For information on using this button, see ["Restarting the Device" on page 68](#) and ["Resetting the Software to Default Settings \(Through the Reset Button\)" on page 103](#).

Restarting the Device

Tip: Alternatively, you may be able to restart the device by pressing and holding the power button  on the device for three to four seconds.

If the device or the home page seems to stop responding, you can reset (restart) the device:

1. Remove the battery compartment cover.

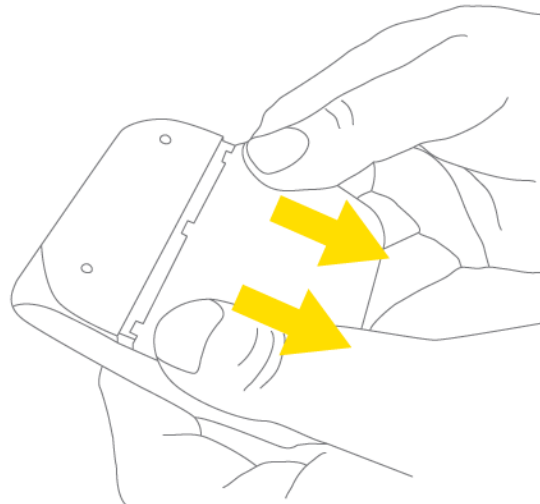

2. Find the small hole below and to the right of the battery compartment. The reset button is inside this hole.

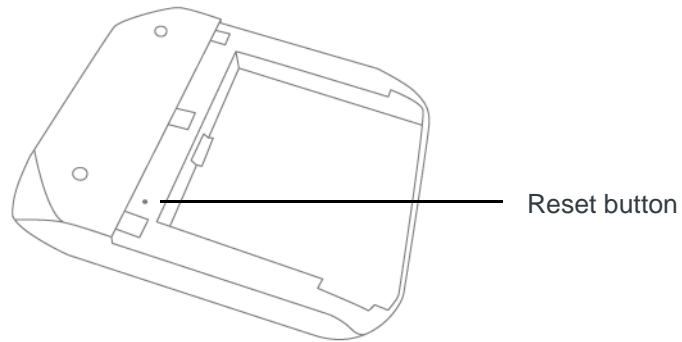

3. Insert a thin object (for example, the end of a paper clip) into the hole, and lightly press on the bottom of the hole for about a second).
4. Replace the battery compartment cover.

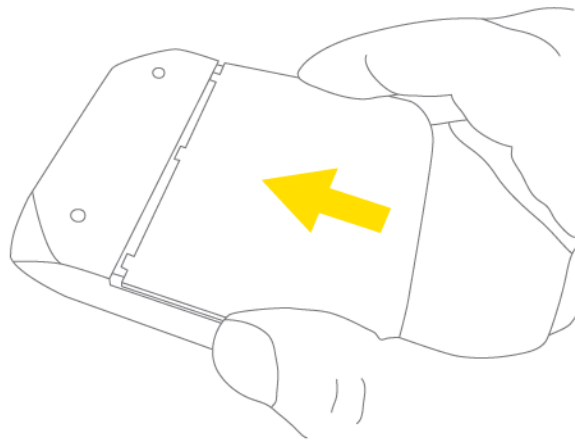

Power Settings

Battery and USB Power Settings

You can specify the settings for battery and USB power:

- **Better battery life** — At the cost of a shorter Wi-Fi range.
- **Longer Wi-Fi range** — At the cost of a shorter battery life.

To choose an option:

1. Ensure you're logged in to the home page.
2. Click the battery icon . The Battery Information and Settings window opens.
— or —
Click **Advanced settings > Wi-Fi > Network**.
3. Select an option in the **Battery or USB Powered** section.

AC Power Settings

You can specify the settings for AC power:

- **Longer Wi-Fi range**
- **Shorter Wi-Fi range**

To choose an option:

1. Ensure you're logged in to the home page.
2. Click the battery icon . The Battery Information and Settings window opens.
— or —
Click **Advanced settings > Wi-Fi > Network**.
3. Select an option in the **AC Powered** section.

Configuring the LCD

Turning the LCD On or Off

1. Log in to the home page.
2. Click **Advanced settings** (.
3. Click **Device > Display**.

4. Set the **LCD Backlight** field to **On** or **Off**. (**Off** helps prolong the battery life, but you can't check the LCD for status icons and messages.)

Setting the LCD Timeout

Tip: Alternatively, you can permanently turn off the LCD, in which case it will never become lit and will not display text and icons. See ["Turning the LCD On or Off" on page 71](#).

To set the amount of time, after which the LCD of the device temporarily turns off:

1. Ensure you're logged in to the home page.
2. Click **Advanced settings > Device > Display**.
3. Ensure **LCD Backlight** is set to **On**.
4. In the Turn Off Backlight list, click a value. (A smaller value helps prolong the battery life.)

Note: The LCD turns on if an important system event occurs.

Setting the LCD Brightness

1. Ensure you're logged in to the home page.
2. Click **Advanced settings > Device > Display**.
3. Ensure **LCD Backlight** is set to **On**.
4. Select a value for **On Battery/USB Power**. (A lower brightness prolongs the battery life.)
5. Select a value for **On AC Power**.

Enabling and Disabling the LED

The power button  on the device acts as an LED/status indicator, and may or may not be lit. For more information, see ["Using the Power Button to Determine the Device State"](#) on page 34.

To enable or disable the lighting of the power button :

1. Log in to the home page.
2. Click **Advanced settings** ()
3. Click **Device > Display**.
4. Set the **Power Button LED** field to **On** or **Off**.

Sounds

Enabling and Disabling Sounds

You can enable or disable sounds of the device through:

- The mute switch on the device (disables all sounds). See ["Mute Switch"](#) on page 36.
- The browser interface (selectively disables sounds). See ["Sounds Information and Settings"](#) on page 58 and ["Enabling and Disabling Sounds for Specific Events"](#) on page 73.

Enabling and Disabling Sounds for Specific Events

1. Log in to the home page.
2. Click **Advanced settings** ()
3. Click **Device > Sounds**.
4. Next to each of the event types, select **Enable** or **Disable**.

Sounds for the following events can be individually enabled or disabled:

- **Low Battery**
Useful as a reminder to charge the device. In the **Alert When** list, you can select a battery level to trigger the alert.
- **System Alerts**
When you hear the device beep, use the device LCD or the Alerts window to get information about the alert. See ["Alert Information"](#) on page 54.

Note: System alerts include several types of events, for example:

- *Critical battery*
- *Critical temperature*
- *Software update available*
- *Network update available*
- *Routing hardware settings reset*
- *Device startup failure*

-
- **Internet Connected**
 - **Internet Disconnected**
 - **Wi-Fi User Has Joined**
Useful, for example, if you're the only one using the device, to detect an intruder.
 - **Wi-Fi User Has Left**
 - **Last User Has Left**
You can turn off the device if nobody will be using it for a while.

Low Battery Alert

You can set an alert to sound when the battery level is low.

Setting the Alert From the Home Page

1. Ensure you're logged in to the home page.
2. Click the Sounds icon ().
3. In the Sounds window, select **Low battery**.

Setting the Alert From the Advanced Settings Window

1. Log in to the home page.
2. Click **Advanced settings** ().
3. Click **Device > Sounds**.
4. For the **Low Battery** field, select **Enable**.
5. In the **Alert When** list, click a battery level to trigger the alert.

Critical Battery Level Alert

You can enable an alert to sound when the battery level is critical (that is, dangerously low).

1. Log in to the home page.
2. Click **Advanced settings** ().
3. Click **Device > Sounds**.
4. For the **System Alerts** field, select **Enable**.

Note: System alerts include several types of events, for example:

- *Critical battery*
 - *Critical temperature*
 - *Software update available*
 - *Network update available*
 - *Routing hardware settings reset*
 - *Device startup failure*
-

Login Settings

Changing the Administrator Password

Note: If you forget the Admin login password, you'll need to reset the device to its default settings and go through the device setup. See ["What Do I Do if I Forgot the Administrator Password?"](#) on page 111.

1. Log in to the home page.
2. Click **Advanced settings** ().
3. Click **Device > Basic**.
4. In the **Admin Password** field, type the new password (1–20 characters/numbers).

Automatic Login ("Remember Me")

If you enable automatic login:

- Anyone who uses the computer will automatically be logged in to the home page (as long as no one else has already logged in from another computer); entering the administrator password is not required.
- The timeout security feature is disabled — you will never be automatically logged off.

To enable automatic login:

1. From the computer that you want to enable automatic login, log in to the home page.
2. In the login area, select the **Remember me** check box.

You can repeat the above steps on other computers; however, since only one administrator can be logged in at a time, only the first person to display the home page will be logged in.

Viewing Computers That Are Set to Automatically Log In as Administrator

1. Log in to the home page.
2. Click **Advanced settings** ().
3. Click **Device > Basic**.
4. Next to **Remember Me Client List**, click **show list**.

Disabling Automatic Login For a Specific Computer

1. Log in to the home page.
2. Click **Advanced settings** ().
3. Click **Device > Basic**.
4. Next to **Remember Me Client List**, click **show list**.

5. In the row for the computer that you want to disable automatic login, click **Remove**.

Advanced Settings

From the Advanced Settings window you can configure all the settings of the device and the browser interface.

The Advanced Settings window has the following tabs; each tab has several panels.

- Device tab. See ["Device Tab" on page 76](#).
- WAN tab. See ["WAN Tab" on page 80](#).
- Wi-Fi tab. See ["Wi-Fi Tab" on page 82](#).
- Router tab. See ["Configuring the Router Tab" on page 93](#).

For help on a tab, click **Help** (). For most fields and buttons, contextual (field-level) Help appears to the right of the window, when you move the cursor over the item. For more information, see ["Contextual Help in the Advanced Settings Window" on page 109](#).

Accessing the Advanced Settings Window

1. Ensure you're logged in to the home page.
2. Click **Advanced settings** (.

Device Tab

Basic Panel

1. Log in to the home page.
2. Click **Advanced settings** (.
3. Click **Device > Basic**.

From this window, you can view and adjust settings, or perform the following actions:

- **Admin Password** — Login password. See ["Changing the Administrator Password" on page 75](#).
- **Remember Me Client List** — View a list of computers that are set to automatically log in. See ["Automatic Login \("Remember Me"\)" on page 75](#).
- **Help for Advanced Settings** — Enable or disable contextual Help in the Advanced Settings window. See ["Contextual Help in the Advanced Settings Window" on page 109](#).
- **Import Router Settings** — Import configuration settings. See ["Importing Settings" on page 105](#).
- **Export Router Settings** — Export configuration settings. See ["Exporting Settings" on page 105](#).
- **Update Firmware From File**. See ["Upgrade Firmware From a File" on page 65](#).

- **Standby Timer on Battery or USB and On AC Power** — Enable standby (low power) mode. See ["Standby \(Low Power\) Mode" on page 56](#).
- **Check for Updates** automatically and **Check for updates now**. See ["Automatically Checking for Updates" on page 64](#) and ["Manually Checking for Updates" on page 65](#).
- **TRU-Install** — Installs the necessary drivers the first time you connect the Clear Spot 4G+ personal hotspot to your Windows or Mac computer. For information on this feature, see ["TRU-Install" on page 43](#).

Display Panel

From the **Display** panel of the **Device** tab, you can configure settings for the device LCD.

1. Log in to the home page.
2. Click **Advanced settings** ()
3. Click **Device > Display**.

From this window, you can view or adjust these settings:

- Lighting of the power button  on the device (**Power Button LED**). See ["Enabling and Disabling the LED" on page 72](#).
- Turn the LCD on or off (**LCD Backlight**). See ["Turning the LCD On or Off" on page 71](#).
- LCD timeout — how soon the LCD goes dormant (Turn Off Backlight). See ["Setting the LCD Timeout" on page 72](#).
- Brightness of the LCD (**Backlight Settings**). See ["Setting the LCD Brightness" on page 72](#).

microSD Card Panel

1. Log in to the home page.
2. Click **Advanced settings** ()
3. Click **Device > microSD Card**.

From this window, you can view and adjust settings, or perform the following actions:

- Status of the microSD card slot.
- Enable the microSD card slot. See ["Enabling the microSD Card Slot" on page 61](#).
- Folder name for the shared micro SD card. See ["microSD Shared Folder Name" on page 61](#).
- Set up access to the microSD Card. See ["Setting Up Access to the microSD Card" on page 61](#).

Sounds Panel

From the Sounds panel of the **Device** tab, you can enable or disable sounds for specific types of events.

1. Log in to the home page.

2. Click **Advanced settings** ().
3. Click **Device > Sounds**.
4. Next to each of the event types, select **Enable** or **Disable**.

Sounds for the following events can be individually enabled or disabled:

- **Low Battery**
Useful as a reminder to charge the device. In the **Alert When** list, you can select a battery level to trigger the alert.
- **System Alerts**
When you hear the device beep, use the device LCD or the Alerts window to get information about the alert. See "[Alert Information](#)" on page 54.

Note: System alerts include several types of events, for example:

- *Critical battery*
- *Critical temperature*
- *Software update available*
- *Network update available*
- *Routing hardware settings reset*
- *Device startup failure*

-
- **Internet Connected**
 - **Internet Disconnected**
 - **Wi-Fi User Has Joined**
Useful, for example, if you're the only one using the device, to detect an intruder.
 - **Wi-Fi User Has Left**
 - **Last User Has Left**
You can turn off the device if nobody will be using it for a while.

About Panel

1. Log in to the home page.
2. Click **Advanced settings** ().
3. Click **Device > About**.

*Note: 4G information is not available if **WAN mode** is "3G only". (**WAN mode** is in **Advanced settings > WAN > Setup**.)*

The following information is displayed:

- **Model Number**
- **Manufacturer**
- **Software Version.**
Firmware version for the routing hardware component of the device.
- **Activation Status.**
3G activated, or not activated.

- **Activation Date.**
Date that the 3G modem was first activated.
- **Network Operator.**
The carrier that your device was activated for.
- **Wi-Fi Firmware Version**
- **Router PRI Version.**
PRI version for the routing hardware component of the device. The PRI (Product Release Instructions) is a file that contains the settings used to configure wireless products for a particular service provider, customer, or purpose.
- **ESN or MEID (3G).**
The ESN (Electronic Serial Number) is the unique first-generation serial number assigned to the 3G component of the device.
The MEID (Mobile Equipment Identifier) is the unique second-generation serial number assigned to the 3G component of the device.
- **PRI Version.**
PRI version of the 3G component of the device. The PRI (Product Release Instructions) is a file that contains the settings used to configure wireless products for a particular service provider, customer, or purpose.
- **MSID (Mobile Station ID)**
The MSID is also known as IMSI (International Mobile Station Identity) — an identifier of a device on the 3G network.
- **PRL Version.**
The PRL (Preferred Roaming List) is an account configuration item set by your service provider. It controls the radio channels and network carrier used by the 3G modem. An updated PRL may improve your 3G network service.
- **Firmware Version.**
Firmware version of the 3G component of the device.
- **MAC Address.**
MAC address of the 4G module. Each wireless device has a unique MAC address (assigned by its manufacturer).
- **Firmware Version.**
Firmware version of the 4G component of the device.

The window also has buttons to:

- Save the information to a text file.
- Reset the 3G/4G configuration of the device to default settings. See ["Resetting the 3G/4G Configuration to Default Settings" on page 92.](#)

Log Panel

1. Log in to the home page.
2. Click **Advanced settings** ().
3. Click **Device > Log**.

From this window, you can:

- Enable logging of system events. See ["Enabling and Disabling Logging of System Events" on page 107](#).
- Enable logging of connects/disconnects. See ["Enabling and Disabling Logging of Connect/Disconnects" on page 106](#).
- Export logs. See ["Exporting System Events" on page 107](#) and ["Exporting the Connection History" on page 106](#).
- Clear logs. See ["Clearing the System Events Log" on page 107](#) and ["Clearing the Connection History" on page 106](#).
- Set the method used for time acquisition. See ["Setting the Method Used for Time Acquisition" on page 107](#).

WAN Tab

See also ["3G Panel" on page 92](#).

Setup Panel

1. Log in to the home page.
2. Click **Advanced settings** ().
3. Click **WAN > Setup**.

From this window, you can view and adjust settings, or perform the following actions:

- **Active Network** — Network that is currently being used for your data connection: 3G, 4G, or none.
- **Network Operator**.
The carrier that your device was activated for.
- **Session Duration** — How long you've been connected to the network.
- **Session Total Data** — Amount of data transferred over the lifetime of the device (by network type) and in the current session.
- **WAN Mode** — Network(s) to connect to, and in what order.
 - **4G Preferred** — Connection can be established to either 3G or 4G; if both are available, 4G is used. This setting is recommended if your service provider has no data limit for 4G, but does for 3G, or you want to take advantage of the faster data transfer speeds of 4G.
 - **4G Only** — Connection can be established only to 4G.
 - **3G Only** — Connection can be established only to 3G.

If you don't have 4G coverage, you can save power by selecting "3G Only".

- **Connect Automatically** to the network when the Clear Spot 4G+ personal hotspot powers on.
- **Failover wait time** — How long the device should wait, after it loses the connection with the preferred network, before it attempts to connect to the other network (not available if **WAN mode** is "3G only" or "4G only").
- **Switchback wait time** — How long the device should wait, when the less-preferred network is connected and the preferred network becomes available, before switching to the preferred network (not available if **WAN mode** is "3G only" or "4G only").
- **Update 3G PRL** — Check whether an updated PRL is available.
The PRL (Preferred Roaming List) is an account configuration item set by your service provider. It controls the radio channels and network carrier used by the 3G modem. An updated PRL may improve your 3G network service.

Note: A 3G connection to the Internet won't be available until the update is complete. (The 4G connection won't be affected).

- **Update 3G Profile** — Check whether an updated profile for your 3G connection is available.
An updated profile may improve your 3G network service.

4G Panel

To access this panel:

1. Log in to the home page.
2. Click **Advanced settings** .
3. Click **WAN > 4G**.

*Note: 4G information is not available if **WAN mode** is "3G only". (**WAN mode** is in **Advanced settings > WAN > Setup**.)*

From this window, you can view this 4G information:

- **Connection Status** — connected, or not connected.
- **Coverage Type** — 4G, 4G Off, or no service.
- **RSSI** and **CINR**.
RSSI reflects the signal strength of the network.
CINR stands for Carrier to Interference-plus-Noise Ratio, and is a measurement of signal effectiveness. For the receiver to decode the carrier signal, the latter must be in an acceptable CINR range.
- **Tx Power** — Transmitter power. A higher number is better.
- **Center Frequency** — Frequency of the 4G channel used for the data connection.
- **NSP-ID** — ID of the 4G Network Service Provider.
- **NAP-ID** — ID of the 4G Network Access Provider.
- **BSID** — Base Station ID.

- **Preamble** — Preamble ID of the current base station that the modem is listening to.
- **Realm** — Login address used for 4G service (user@realm).
- **Certificate information**

Wi-Fi Tab

Network Panel



1. Log in to the home page.
2. Click **Advanced settings** ()
3. Click **Wi-Fi > Network**.

From this window, you can view and adjust settings, or perform the following actions:

- **Disable Wi-Fi upon USB-PC** — Only a computer that is connected to the device through the USB cable can use the device. See ["Disabling Wi-Fi When Connected Through USB" on page 91](#).
- **SSID** — Wi-Fi network name; identifies your Wi-Fi network and is visible to other Wi-Fi-enabled devices. See ["SSID \(Wi-Fi Network Name\)" on page 84](#).
- **Hostname** — Device name. See ["Host Name \(Device Name\)" on page 90](#) and ["Displaying the Home Page of the Device" on page 46](#).
- **Link SSID and Hostname**. See ["Linking the SSID and the Host Name" on page 85](#).

If you link the **SSID** (Wi-Fi network name) and the **Hostname** (name of your device):

- The SSID becomes whatever the Hostname is (you cannot change the SSID — only the Hostname).
- You only need to remember one name when selecting the Wi-Fi network, accessing the browser interface, or accessing the microSD card.
- **SSID Broadcast**
If broadcast is enabled, the wireless network is displayed in the list of Wi-Fi networks available in the local area. For increased security, set this field to **Disable**. You will need to give the SSID to the people who will be accessing your network.
- **Max Number of Users**
Limits the number of Wi-Fi users that can connect to the device. A smaller number improves performance and security.
- **Battery or USB Powered** (power settings)
 - **Better battery life** — At the cost of a shorter Wi-Fi range.
 - **Longer Wi-Fi range** — At the cost of a shorter battery life.
- **AC Powered** (power settings)
 - **Longer Wi-Fi range**
 - **Shorter Wi-Fi range**
- **Wi-Fi Channel**
The Wi-Fi channel is the active channel of the Wi-Fi access point. If your network is having performance issues (possibly caused by other Wi-Fi networks in the vicinity using the same channel), try a different Wi-Fi channel.

- **Basic Rate** — Type of wireless devices connected to your network.
If you're certain that all of the Wi-Fi devices used with your device support 802.11g, then select **802.11g only** (this ensures faster Wi-Fi speeds); otherwise, select **802.11b/g compatibility**.
- **RTS Threshold**
Specifies the smallest packet size, in bytes, for which RTS/CTS (Request to Send/Clear to Send) handshaking is used. The recommended value is 2347. Change this value only if you're experiencing inconsistent data flow. Make only minor changes to this value.
- **Fragmentation Threshold**
Specifies the largest allowable size, in bytes, for a packet. If the packet is larger than this, it is fragmented into multiple packet before it is transmitted. To prevent poor network performance, it's recommended to keep this value as large as possible (up to 2346).
- **List of connected devices** — Display a window that shows connected computers.
A row may optionally show one or both of these icons:
 -  — The user of this computer is logged in as administrator.
 -  — This computer is connected to the device through the USB cable.

Security Panel

1. Log in to the home page.
2. Click **Advanced settings** ().
3. Click **Wi-Fi > Security**.

From this window, you can set the:

- Wi-Fi security type. See "[Wi-Fi Security](#)" on page 86.
- Wi-Fi password. See "[Wi-Fi Password](#)" on page 87.
- Wi-Fi Password Reminder feature. See "[Wi-Fi Password Reminder](#)" on page 88.

MAC Filter Panel

The MAC (Media Access Control) filter is used to grant ("whitelist") or block ("blacklist") wireless devices access to the Wi-Fi, 3G, and 4G networks. Access is based on the MAC address of each wireless device.

MAC filtering can prevent unauthorized wireless devices from connecting to your network.

MAC filtering increases security of your network. You can give access to your network, based on the MAC address of the wireless devices. This makes it harder for a hacker to use a MAC address to access your network.

To access this panel:

1. Log in to the home page.
2. Click **Advanced settings** ().
3. Click **Wi-Fi > MAC Filter**.

From this window, you can:

- Display a list of computers that are:
 - Allowed to access the network (**MAC Filter Mode** = "Allow all in list")
 - Not allowed to access the network (**MAC Filter Mode** = "Block all in list")
- Add or remove a computer from the lists. See ["Specifying Computers That Can Access the Network"](#) on page 88 and ["Specifying Computers That Are Not Allowed to Access the Network"](#) on page 89.
- Display a list of computers that are currently connected through Wi-Fi. See ["Displaying a List of Currently Connected Computers"](#) on page 90.

Configuring the Wi-Fi Network

You can configure basic settings of the Wi-Fi network through the setup pages.

1. Ensure you're logged in to the home page.

2. Click **Admin setup** ()

For more information, see ["Changing the Password and Settings"](#) on page 38.

You can configure basic and advanced settings of the Wi-Fi network through the **Advanced settings** window.

1. Log in to the home page.

2. Click **Advanced settings** ()

3. Click **Wi-Fi > Network**.

For more information, see ["Network Panel"](#) on page 82.

See also:

- ["Disabling Wi-Fi When Connected Through USB"](#) on page 91.
- ["Battery and USB Power Settings"](#) on page 71.
- ["AC Power Settings"](#) on page 71

SSID (Wi-Fi Network Name)

The SSID identifies your Wi-Fi network and is visible to other Wi-Fi-enabled devices.

It appears on your device's LCD screen; if more than one Clear Spot 4G+ personal hotspot is available, you can use this name to tell the devices apart.

You can display the home page by typing the SSID in your Web browser (if **Link SSID and Hostname** is selected; see ["Linking the SSID and the Host Name"](#) on page 85).

You should make the SSID unique and change it on a regular basis for optimal security.

To change the SSID:

1. Log in to the home page.
2. Click **Advanced settings** ().
3. Click **Wi-Fi > Network**.
4. In the **SSID** field, enter the new name.
If the **SSID** field is not available, Link SSID and Hostname is enabled. You must either edit **Hostname** (and the SSID will get the same value), or disable **Link SSID and Hostname** and edit the SSID.
5. Click **Save**.
6. Reconnect to Wi-Fi: follow the instructions on-screen, and see ["How Do I Connect to Wi-Fi?" on page 110](#).

Note: If you're sharing your connection with others, they also must reconnect to Wi-Fi; provide them the new SSID.

For security reasons, it's recommended you disable SSID Broadcast. See ["Network Panel" on page 82](#).

Linking the SSID and the Host Name

If you link the **SSID** (Wi-Fi network name) and the Hostname (name of your device):

- The SSID becomes whatever the Hostname is (you cannot change the SSID — only the Hostname).
- You only need to remember one name when selecting the Wi-Fi network, accessing the browser interface, or accessing the microSD card.

To link the SSID and the Hostname:

1. Log in to the home page.
2. Click **Advanced settings** ().
3. Click **Wi-Fi > Network** or **Router > LAN**.
4. Select the **Link SSID and Hostname** check box.
The **SSID** field gets the value of Hostname and becomes unavailable (grayed out).
5. Click **Save**.
The device resets, after which you must reconnect to Wi-Fi. See ["How Do I Connect to Wi-Fi?" on page 110](#).

Wi-Fi Security

By default, Wi-Fi security is enabled for your device and the Wi-Fi network.

Note: All the devices used with the Clear Spot 4G+ personal hotspot must support the selected security type.

To change the security used by Wi-Fi:

1. Log in to the home page.
2. Click **Advanced settings** ().
3. Click **Wi-Fi > Security**.
4. Select one of the options:
 - **None**
No security (no password is required to access the Wi-Fi network); not recommended. Anyone may access your device and use your Internet connection (you are responsible for payment for data usage).
 - **WEP-64 Bit - Shared**
Lower security. Works with older and newer Wi-Fi devices. Recommended only if any of your devices don't support WPA or WPA2. Shared WEP uses the same key for encryption and authentication; some consider shared WEP to be less secure than open WEP.
 - **WEP-128 Bit - Shared**
Lower security. Works with older and newer Wi-Fi devices. Recommended only if any of your devices don't support WPA or WPA2. Shared WEP uses the same key for encryption and authentication; some consider shared WEP to be less secure than open WEP.
 - **WEP-64 Bit - Open**
Lower security. Works with older and newer Wi-Fi devices. Recommended only if any of your devices don't support WPA or WPA2. Open WEP uses the key for encryption, but not for authentication.
 - **WEP-128 Bit - Open**
Lower security. Works with older and newer Wi-Fi devices. Recommended only if any of your devices don't support WPA or WPA2. Open WEP uses the key for encryption, but not for authentication.
 - **WPA-Personal - TKIP**
A strong security standard, supported by most Wi-Fi devices.
 - **WPA-Personal - TKIP/AES**
A strong security standard, supported by most Wi-Fi devices.
 - **WPA2-Personal - AES**
A stronger, newer security standard. Limited to newer Wi-Fi devices.
 - **WPA2-Personal - TKIP/AES**
A stronger, newer security standard. Limited to newer Wi-Fi devices.
 - **WPA/WPA2 Personal** (recommended setting)
Wi-Fi devices that use either WPA or WPA2 can connect to the device. Supported by most Wi-Fi devices.

5. Click **Save**.

The option you select determines the Wi-Fi security used and also the maximum length of the Wi-Fi password.

Wi-Fi Password

If Wi-Fi security is enabled, a Wi-Fi password is required to connect to the Wi-Fi network.

Some general rules to make your password more secure:



- Use letters and numbers
- Use special characters (for example, @)
- Use both uppercase and lowercase letters

To change the Wi-Fi password:

1. Log in to the home page.
2. Click **Advanced settings** ().
3. Click **Wi-Fi > Security**.
4. In the **Wi-Fi Password** field, type the password; the maximum length depends on the Wi-Fi security type that you've selected.
 - **None**
No security (no password is required to access the Wi-Fi network); not recommended. Anyone may access your device and use your Internet connection (you are responsible for payment for data usage).
 - **WEP-64 bit - Shared**
5 ASCII characters.
 - **WEP-128 bit - Shared**
13 ASCII characters.
 - **WEP-64 bit - Open**
5 ASCII characters.
 - **WEP-128 bit - Open**
13 ASCII characters.
 - **WPA-Personal - TKIP**
ASCII string, 8 to 63 characters.
 - **WPA-Personal - TKIP/AES**
ASCII string, 8 to 63 characters.
 - **WPA2-Personal - AES**
ASCII string, 8 to 63 characters.
 - **WPA2-Personal - TKIP/AES**
ASCII string, 8 to 63 characters.
 - **WPA/WPA2 Personal**
ASCII string, 8 to 63 characters.
5. Click **Save**.

Wi-Fi Password Reminder

When the Wi-Fi Password Reminder feature is enabled, you can display the Wi-Fi password on the LCD of the device:

1. If the LCD is dark (no text or icons are displayed):
 - a. Ensure the LCD is enabled. See ["Turning the LCD On or Off" on page 71](#).
 - b. Briefly press the power button  on the device.
2. Press the power button  on the device twice, quickly (within 0.5 seconds).

The information is displayed for approximately 20 seconds. To clear the information before that, briefly press the power button  on the device.

Enabling the Wi-Fi Password Reminder

1. Log in to the home page.
2. Click **Advanced settings** ().
3. Click **Wi-Fi > Security**.
4. In the **Password Reminder** section, select **On**.
5. Click **Save**.

Allowing or Denying Computers Access to the Network

The MAC (Media Access Control) filter is used to grant ("whitelist") or block ("blacklist") wireless devices access to the Wi-Fi, 3G, and 4G networks. Access is based on the MAC address of each wireless device.

MAC filtering can prevent unauthorized wireless devices from connecting to your network.

You can choose one of three modes:

- **No filtering** — All computers are allowed to access the network.
- **Allow all in list** — Only computers that are in this list are allowed to access the network.
- **Block all in list** — All computers are allowed to access the network, unless they're in this list.

In any case, a user still needs to provide the correct Wi-Fi password to access the network.

Specifying Computers That Can Access the Network

1. Log in to the home page.
2. Click **Advanced settings** ().
3. Click **Wi-Fi > MAC Filter**.
4. In the **MAC Filter Mode** list, click **Allow all in list**.
5. Do one of the following:
 - If the computer you want to allow access is currently connected to the Clear Spot 4G+ personal hotspot, click **List of connected devices**. In the row for the computer, click **Add**.

- Click **Add**.
In the **MAC Address** field, enter the MAC address of the computer you're adding to the list. (If you don't know this address, see ["Finding the MAC Address" on page 114.](#))
In the **Name** field, enter a name, for example "Amy's PC".
- 6. Repeat step 5 for each computer you want to allow access.

Specifying Computers That Are Not Allowed to Access the Network



1. Log in to the home page.
2. Click **Advanced settings** ().
3. Click **Wi-Fi > MAC Filter**.
4. In the **MAC Filter Mode** list, click **Block all in list**.
5. Determine and block an undesired user of your network.
 - a. Click the **List of connected devices** link.
 - b. If you see a device you don't recognize, you can compare its MAC address to the MAC address of each of the devices on your network.
To determine the MAC address of each device you have, see ["Finding the MAC Address" on page 114.](#) If none of your devices have this MAC address, that device might be an intruder.
 - c. In the row for the device you want to block, click **Add**.
6. For each computer you want to block, repeat step 5.

Tip: *The Connected Users window has a **Block** check box, available for each currently connected user (except the administrator []). See ["Wi-Fi Users Information and Settings" on page 55.](#)*

Removing a Computer From the Allowed or Disallowed Lists

1. Log in to the home page.
2. Click **Advanced settings** ().
3. Click **Wi-Fi > MAC Filter**.
4. In the **MAC filter mode** list, click either **Allow all in list** or **Block all in list**.
5. Click the row that you want to remove.
A row of buttons (**Delete**, **OK**, **Cancel**) appears.
6. Click **Delete**.

Displaying a List of Currently Connected Computers

1. Ensure you're logged in to the home page.
2. Click the  icon to display the Connected Users window.
— or —
Click **Advanced settings > Wi-Fi > Mac Filter**, and click **List of connected devices**.
A row displays the  icon if the user is logged in as administrator.

Host Name (Device Name)

The host name is, in essence, a name you're giving the device.

The host name is shown on your device's LCD screen; if more than one device is available, you can use this name to tell the devices apart. See ["Linking the SSID and the Host Name" on page 85](#).

This name is also used when you type a command to access the:

- Home page. See ["Displaying the Home Page of the Device" on page 46](#).
- microSD card. See ["Accessing the microSD Card" on page 63](#).

To change the host name:

1. Log in to the home page.
2. Click **Advanced settings** ().
3. Click **Wi-Fi > Network** or **Router > LAN**.
4. In the Hostname field, enter a name for your device.

Input rules:

1-15 ASCII characters. Valid characters are:

- a-z
- A-Z
- 0-9. Note that the host name cannot be all numbers.
- - (hyphen). Note that the host name cannot start or end with a hyphen.

Setting the Maximum Number of Wi-Fi Users

If your network is having performance issues, you might want to decrease the number of Wi-Fi users allowed to connect to the device.

1. Ensure you're logged in to the home page.
2. Click the  icon and, in the Connected Users window, click a value in the **Max Wi-Fi users** list.
— or —
Click **Advanced settings > Wi-Fi > Network**, and click a value in the **Max Number of Users** list.

Wi-Fi Channel

The Wi-Fi channel is the active channel of the Wi-Fi access point. If your network is having performance issues (possibly caused by other Wi-Fi networks in the vicinity using the same channel), try a different Wi-Fi channel.

1. Log in to the home page.
2. Click **Advanced settings** ().
3. Click **Wi-Fi > Network**.
4. Click a channel in the Wi-Fi **Channel** list, or, to have the device automatically determine the channel to use, click **Auto**.

Disabling Wi-Fi When Connected Through USB

You can optionally turn off the device's Wi-Fi when connected via the USB cable. In this case:

- Only a computer that is connected to the device through the USB cable can use the device.
- You can prolong the battery life of the device.
- The battery charges faster.

To enable this feature:

1. Ensure you're logged in to the home page.
2. Click the Connected Users icon (for example, ) and select **Disable Wi-Fi when connected via USB**.

— or —

Click **Advanced settings > Wi-Fi > Network** and set **Disable Wi-Fi upon USB-PC** to **On**.

Configuring 3G/4G

Viewing 3G Activation Information

1. Log in to the home page.
2. Click **Advanced settings** ().
3. Click **Device > About**.

The following fields are related to 3G activation:

- **Activation Status**
Activated, or not activated.
- **Activation Date**
Date that the 3G modem was first activated.
- **Network Operator**
The carrier that your device was activated for.

3G Panel

1. Log in to the home page.
2. Click **Advanced settings** ().
3. Click **WAN > 3G**.

From this window, you can view or update this information, or perform these actions:

- **Connection Status:** connected, not connected, or dormant.
Dormant means a connection is established, but no data is being transferred.
- **Service Type** used for the data connection (1xRTT, EVDO, or EVDO Rev. A).
- **Coverage Type** available, and RSSI and Ec/Io for each type.
RSSI reflects the signal strength of the network.
Ec/Io is a dimensionless ratio of the average power of a channel, typically the pilot channel, to the total signal power.
- **MDN** (Mobile Directory Number) — a 10-digit phone number.
- **SID** (System ID)
The System ID identifies your home network area.
- **MSID** (Mobile Station ID)
The MSID is also known as IMSI (International Mobile Station Identity) — an identifier of a device on the 3G network.
- **NAI** (Network Access Identifier)
The NAI is a user ID for accessing the 3G network.
- **PRL Version**
The PRL (Preferred Roaming List) is an account configuration item set by your service provider. It controls the radio channels and network carrier used by the 3G modem. An updated PRL may improve your 3G network service.
- **Load 3G PRL** — For example, you've received via email or downloaded a file).
Alternatively, you can check online for a PRL update — in **Advanced settings > WAN > Setup**, click **Update 3G PRL**.

Resetting the 3G/4G Configuration to Default Settings

Note: Reset the configuration only if instructed by a CLEAR representative.

After a configuration reset:

- You must go through the device setup ([page 37](#)) and 3G activation (the latter starts automatically).
 - Any changes you've made to the settings are lost.
-

1. Log in to the home page.
2. Click **Advanced settings** ().
3. Click **Device > About**.
4. Click **Reset Device to Factory Defaults**.

5. When prompted, enter the SPC (Service Programming Code). (If you don't know your SPC, contact CLEAR.)

You won't be able to establish a data connection until you:

1. Go through the device setup ([page 37](#)).
2. Go through 3G activation or, if using 4G, use pay-as-you-go.

Configuring the Router Tab

You can configure the routing hardware component of the device through the **Advanced Settings** window.

1. Log in to the home page.
2. Click **Advanced settings** (.
3. Click **Router**.
4. Depending on the settings you want to configure, click one of the panels:
 - **Basic**. See "[Basic Panel](#)" on [page 93](#).
 - **LAN**. See "[LAN Panel](#)" on [page 94](#).
 - **Port Forward**. See "[Port Forward Panel](#)" on [page 98](#).
 - **Port Trigger**. See "[Port Trigger Panel](#)" on [page 100](#).
 - **DMZ**. See "[DMZ Panel](#)" on [page 102](#).

Basic Panel

1. Log in to the home page.
2. Click **Advanced settings** (.
3. Click **Router > Basic**.

From this window, you can enable or disable these features, or perform these actions:

- **Port forwarding**. See "[Port Forward Panel](#)" on [page 98](#).
- **Port triggering**. See "[Port Trigger Panel](#)" on [page 100](#).
- **DMZ**. See "[DMZ Panel](#)" on [page 102](#).
- **UPnP** (universal plug and play). See "[UPnP \(Universal Plug and Play\)](#)" on [page 94](#).
- **SPI** (stateful packet inspection). See "[SPI \(Stateful Packet Inspection\)](#)" on [page 94](#).
- **Router Settings Reset** — Reset the software to default settings. See "[Resetting the Software to Default Settings \(Through the Browser Interface\)](#)" on [page 104](#).

UPnP (Universal Plug and Play)

UPnP provides simple and robust connectivity among consumer electronics, intelligent appliances, and mobile devices from many different vendors. For more information, see www.upnp.org.

Note: If UPnP is enabled, there are potential security risks.

Enabling UPnP

Before you can use UPnP, you must enable it.

1. Log in to the home page.
2. Click **Advanced settings** ().
3. Click **Router > Basic**.
4. Next to **UPnP**, select **Enable**.

SPI (Stateful Packet Inspection)

SPI, also known as "dynamic packet filtering," helps to prevent cyberattacks by validating that the traffic passing through a session conforms to the protocol used for this type of session. Packets that are not conforming get rejected.

Enabling SPI

Before you can use SPI, you must enable it.

1. Log in to the home page.
2. Click **Advanced settings** ().
3. Click **Router > Basic**.
4. Next to **SPI**, select **Enable**.

LAN Panel

1. Log in to the home page.
2. Click **Advanced settings** ().
3. Click **Router > LAN**.

From this window, you can view and adjust settings, or perform the following actions:

- **Router IP Address** (on the LAN).
- **Subnet Mask**
The routing hardware's internal LAN subnet mask.
- **Hostname** (Device name). See "[Host Name \(Device Name\)](#)" on page 90 and "[Displaying the Home Page of the Device](#)" on page 46.
- **SSID** (Wi-Fi network name). See "[SSID \(Wi-Fi Network Name\)](#)" on page 84.
- **Link SSID and Hostname**. See "[Linking the SSID and the Host Name](#)" on page 85.

- **DHCP Server** (enable DHCP)

Note: The following items are displayed only when DHCP is enabled.

- **DHCP IP Address Range**

The starting and ending address of the range of IP addresses available for the device to dynamically (that is, not permanently) assign to computers connected to it.

- **DHCP Lease Time**

Amount of time, in minutes, a computer can use its assigned IP address before it is required to renew the lease. After this time is up, the computer is automatically assigned a new dynamic IP address.

Enter a number between 2 and 10080.

- **Max DHCP Clients**

The number of DHCP addresses that can be assigned and active at one time. It's recommended you set this to a number greater than the number of Wi-Fi users.

- **DNS Mode**

The **DNS Mode** setting specifies how the DNS servers (that the DHCP clients are to communicate with) are obtained.

- **Auto:** Use the DNS server specified by CLEAR. **DNS Relay** is enabled by default.

- **Manual:** The routing hardware assigns DHCP clients the DNS servers specified in the **Manual DNS Server #1** and **#2** fields.

Use this option to access a DNS server that provides customized addressing or if you have a local DNS server on your network.

If **DNS Relay** is disabled, the routing hardware rejects DNS requests targeting the internal DNS proxy.

- **Manual DNS Server #1** and **#2** — Static IP addresses to use for the DNS servers (if DNS Mode is Manual).

Available only if **DNS Mode** is Manual.

- **DNS Relay**

If enabled, and if **DNS Mode** (see above) is Manual, the routing hardware assigns DHCP clients the DNS servers specified in the **Manual DNS Server #1** and **#2** fields.

If disabled, the routing hardware rejects DNS requests targeting the internal DNS proxy.

The **DNS Relay** field is configurable and displayed only if **DNS Mode** is Manual. If **DNS Mode** is Auto, DNS Relay is enabled by default.

- **DHCP Static IP Assignment List** — Assign a permanent IP address to a MAC address, and view the static IP assignment list. See "[DHCP Static IP Assignment List](#)" on page 97.

DHCP

DHCP (Dynamic Host Control Protocol) automatically assigns an IP address to each device on the network and manages other network configuration information for devices connected to your network. You do not need to manually configure the IP address on each device that's on your network.

The assigned IP addresses are not permanent (as opposed to when using static IP).

Most ISPs (Internet Service Providers) use DHCP.

Normally, you should enable DHCP, in which case you must configure each device on the network with one of the following:

- TCP/IP settings set to "Obtain an IP address automatically"
- TCP/IP bound to the Ethernet connection with DHCP

If DHCP is disabled, you must configure each device on the network with:

- Fixed (permanent/static) IP address.
- DNS server addresses (provided by CLEAR).

Enabling DHCP

1. Log in to the home page.
2. Click **Advanced settings** ()
3. Click **Router > LAN**.
4. Next to **DHCP Server**, select **Enable**.

Configuring DHCP

To configure DHCP settings, DHCP must be enabled (**Advanced settings > Router > LAN > DHCP Server**).

You can set the following DHCP settings in **Advanced settings > Router > LAN**:

- **DHCP IP Address Range**

The starting and ending address of the range of IP addresses available for the device to dynamically (that is, not permanently) assign to computers connected to it.

The start address must be 192.168.0.10 or above.

The ending address must be 192.168.0.50 or below.
- **DHCP Lease Time**

Amount of time, in minutes, a computer can use its assigned IP address before it is required to renew the lease. After this time is up, the computer is automatically assigned a new dynamic IP address.

Enter a number between 2 and 10080.
- **Max DHCP Clients**

The number of DHCP addresses that can be assigned and active at one time. It's recommended you set this to a number greater than the number of Wi-Fi users.

- **DNS Mode**

The **DNS Mode** setting specifies how the DNS servers (that the DHCP clients are to communicate with) are obtained. See ["DNS Mode" on page 98](#).

- **DHCP Static Assignment List** — Assign a permanent (static) IP address to a device on your network, and view the static IP assignment list. See the next section.

DHCP Static IP Assignment List

With DHCP, IP addresses are assigned dynamically; devices typically don't have a permanent IP address.

However, in some cases you might want to assign a static (permanent) IP address to a device, while still using DHCP for the rest of the devices on your network. This is also known as "DHCP reservation". You might want to do this with, for example, a Web server, FTP server, media server.

Viewing the Static IP Assignment List

1. Log in to the home page.
2. Click **Advanced settings** ().
3. Click **Router > LAN**.
4. Ensure DHCP is enabled (**DHCP Server**).
5. Click **DHCP Static IP Assignment List**.

Assigning an IP Address Based on a MAC Address

1. Follow the above steps to display the DHCP Static IP Assignment List window.
2. In the **Hostname** field, enter a meaningful description of the device.
3. In the **MAC Address** field, enter the MAC Address of the device. (If you don't know this address, see ["Finding the MAC Address" on page 114](#).)
4. In the **IP Address** field, enter the IP address you want to assign to the device.
5. Select the **Enable** check box to have the device use the designated IP address.
6. Click **Add**.
7. Click **save**.

Removing an IP Address Based on a MAC Address

1. Click **DHCP Static IP Assignment List** on the **LAN** panel of the **Router** tab.
2. To keep the device information in the list (in case you want to re-enable DHCP for this MAC address later on), clear the **Enable** check box.

— or —

To remove the device from the list:

- a. Click the row that you want to remove.
A row of buttons (**Delete**, **OK**, **Cancel**) appears.
- b. Click **Delete**.

DNS Mode

The **DNS Mode** setting specifies how the DNS servers (that the DHCP clients are to communicate with) are obtained.

1. Log in to the home page.
2. Click **Advanced settings** ()
3. Click **Router > LAN**.
4. Set **DNS Mode** to one of the following:
 - **Auto:** Use the DNS server specified by CLEAR. **DNS Relay** is enabled by default.
 - **Manual:** The routing hardware assigns DHCP clients the DNS servers specified in the **Manual DNS Server #1** and **#2** fields.
Use this option to access a DNS server that provides customized addressing or if you have a local DNS server on your network.
If **DNS Relay** is disabled, the routing hardware rejects DNS requests targeting the internal DNS proxy.

For information on DNS Relay, see ["LAN Panel" on page 94](#).

Port Forward Panel

Normally, incoming traffic (from the Internet) is blocked. However, port forwarding lets you forward incoming traffic to specific ports and devices (per their local IP address) on your network. For example, you can configure port forwarding so that:

- You can access your Remote Desktop from the Internet (by specifying the WAN [public] IP address that the device is using).
- Internet users can access a Web, FTP, or email server, or gaming or Internet application hosted by your computer.

Note: Port forwarding creates a security risk. When not required, port forwarding should be disabled.

Port forwarding does not apply to normal browsing, file downloading, running most online games or other applications hosted on the Internet. (Some online games require port forwarding.)

Before you can use or configure port forwarding, you must enable it. See ["Enabling Port Forwarding" on page 99](#).

From the **Port Forward** panel of the **Router** tab of the **Advanced Settings** window, you can:

- Enable port forwarding for an application. See ["Enabling Port Forwarding for an Application" on page 99](#).
- Remove an application from the port forwarding list. See ["Disabling Port Forwarding for an Application" on page 99](#).

Enabling Port Forwarding

Before you can use or configure Port Forwarding, you must enable it.

1. Log in to the home page.
2. Click **Advanced settings** ().
3. Click **Router > Basic**.
4. Next to **Port Forwarding**, select **Enable**.
5. Click **Save**.

Enabling Port Forwarding for an Application

1. Ensure you've enabled port forwarding. See ["Enabling Port Forwarding" on page 99](#).
2. Display the "Port forward" window.
 - a. Log in to the home page.
 - b. Click **Advanced settings** ().
 - c. Click **Router > Port Forward**.
3. In the last row of the table, click the **Application** field, and select the application type from the list.

The values for **Start** and **End** ports are automatically filled in.
4. If necessary, change the range of port numbers associated with the application. Traffic will be allowed (not blocked) if its destination port number is in the specified range.
 - a. In the **Start** field, enter the number that starts the port range.
 - b. In the **End** field, enter the number that ends the port range.

If the range consists of only one port, enter the number that you entered in the **Start** field.
5. In the **Protocol** list, click the protocol(s) used for this application (TCP, UDP, or both).
6. In the **IP Address** field, enter the IP address of the server to be accessed.
7. Ensure **Enable** is selected.
8. Click **Add**.
9. Click **save**.

Disabling Port Forwarding for an Application

1. Ensure you've enabled port forwarding. See ["Enabling Port Forwarding" on page 99](#).
2. Display the "Port forward" window.
 - a. Log in to the home page.
 - b. Click **Advanced settings** ().
 - c. Click **Router > Port forward**.

3. To keep the application in the list (in case you want to re-enable port forwarding later on), clear the **Enable** check box.

— or —

To remove the application from the list:

- a. Click the row that you want to remove.
A row of buttons (**Delete**, **OK**, **Cancel**) appears.
- b. Click **Delete**.

Port Trigger Panel

Some applications require multiple ports open for communication, many of which may be initiated by a computer on the WAN. Examples of this include video conferencing, VoIP (Internet telephony), and Internet gaming.

With port triggering, the device monitors outgoing data on specific port numbers (trigger ports).

The device keeps track of the IP address of the computer that sends data on these trigger ports, so that when incoming data on the Forward ports arrives, the device sends the incoming data to the same computer.

Before you can use or configure port triggering, you must enable it. See ["Enabling Port Triggering" on page 100](#).

From the **Port Trigger** panel of the **Router** tab of the **Advanced Settings** window, you can:

- Enable port triggering for specified protocols and ports. See ["Enabling Port Triggering for Specified Protocols and Ports" on page 100](#).
- Remove protocols and ports from the port triggering list. See ["Removing Ports from the Port Triggering List" on page 101](#).

Enabling Port Triggering

Before you can use or configure Port Triggering, you must enable it.

1. Log in to the home page.
2. Click **Advanced settings** (.
3. Click **Router > Basic**.
4. Next to **Port Triggering**, select **Enable**.

Enabling Port Triggering for Specified Protocols and Ports

1. Ensure you've enabled port triggering. See ["Enabling Port Triggering" on page 100](#).
2. Display the "Port trigger" window.
 - a. Log in to the home page.
 - b. Click **Advanced settings** (.
 - c. Click **Router > Port Trigger**.

3. In the last row of the table, in the first **Protocol** list, click the protocol(s) used by the application for outgoing traffic (to the Internet, sent through the trigger ports).
4. In the **Trigger Ports** field, enter the port number(s) used to determine that the application is in use (that is, specify the port number or range of port numbers that the application uses for outgoing traffic). (Check the user documentation for the application.)
To specify a range of port numbers, separate the start and end port number with a hyphen.
5. In the second **Protocol** list, click the protocol(s) used by the application for incoming traffic (from the Internet).
6. In the **Forward Ports** field, enter the ports to forward to the computer that triggered the rule (that is, specify the port number or range of port numbers that the application uses for incoming traffic). (Check the user documentation for the application.)
To specify a range of port numbers, separate the start and end port number with a hyphen.
7. Ensure **Enable** is selected.
8. Click **Add**.
9. Click **Save**.

Removing Ports from the Port Triggering List

1. Ensure you've enabled port triggering. See ["Enabling Port Triggering" on page 100](#).
2. Display the "Port trigger" window.
 - a. Log in to the home page.
 - b. Click **Advanced settings** .
 - c. Click **Router > Port Trigger**.
3. To keep the entry in the list (in case you want to re-enable this entry later on), clear the **Enable** check box.
— or —
To remove the entry from the list:
 - a. Click the row that you want to remove.
A row of buttons (**Delete**, **OK**, **Cancel**) appears.
 - b. Click **Delete**.

DMZ Panel

DMZ stands for "demilitarized zone". You can select one computer to receive all unsolicited incoming connections.

The IP address of the DMZ is the default recipient of incoming packets (from the Internet) that are not handled by port forwarding rules, port triggering rules, or NAT'd connections:

1. If port forwarding, port triggering, or both are enabled, incoming traffic is routed according to the port forwarding rules, port triggering rules, or NAT'd connections.
2. If incoming traffic was not routed as a result of the above:
 - If DMZ is enabled, then incoming traffic is routed to the computer that uses the IP address specified by the DMZ settings.
 - If DMZ is not enabled, the incoming traffic is blocked.

Note: Putting a computer in the DMZ opens all the ports of that computer, and exposes that computer to various security risks. Use this option only as a last resort — if possible, use other options instead (for example, port forwarding or port triggering).

Before you can use or configure DMZ, you must enable it.

Enabling DMZ

Before you can use or configure DMZ, you must enable it.

1. Log in to the home page.
2. Click **Advanced settings** .
3. Click **Router > Basic**.
4. Next to **DMZ**, select **Enable**.
5. Click **Save**.

Configuring DMZ

To configure DMZ:

1. Ensure you've enabled DMZ. See ["Enabling DMZ" on page 102](#).
2. Display the DMZ panel of the Router tab.
 - a. Log in to the home page.
 - b. Click **Advanced settings** .
 - c. Click **Router > DMZ**.
3. Specify the computer that you want exposed to the Internet: in the **Destination IP Address** field, enter the IP address of the computer.

If you don't know how to find the IP address, see ["Finding the IP Address" on page 115](#).
4. In the **Source IP Address** section, specify what incoming traffic (not handled by port forwarding, port triggering, or NAT) to forward to this computer.

To forward all incoming traffic, click **Any**.

— or —

To forward incoming traffic from certain IP addresses:

- a. Click **Restriction**.
 - b. In the two additional fields that are displayed, enter the start and end IP addresses of a range.
5. Using the DHCP Static IP Assignment List, assign an IP address based on the MAC address of the computer that is in the DMZ. See "[Assigning an IP Address Based on a MAC Address](#)" on page 97.

— or —

On the computer that is in the DMZ, disable DHCP, and manually assign the IP address, gateway, and DNS server.

Resetting the Software to Default Settings

Warning: If you reset the software to default settings:

- You must go through the device setup ([page 37](#)), as if you've just purchased the device.
 - Any changes you've made to the settings are lost.
- Your 3G and 4G account information is not affected; after reset, the device remains provisioned for service.

You'll need to reset the software to default settings if:

- You've forgotten the administrator password.
- You've changed the DHCP settings such that the device is inoperable (for example, there's no communication with the device).

You have two options to initiate the reset:

- Through the software. See "[Resetting the Software to Default Settings \(Through the Browser Interface\)](#)" on page 104.
- Through the reset button on the device. See the following section.

Resetting the Software to Default Settings (Through the Reset Button)

1. Remove the battery compartment cover.

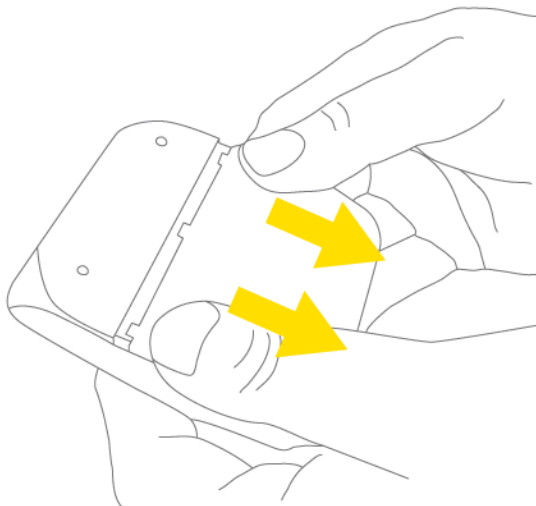

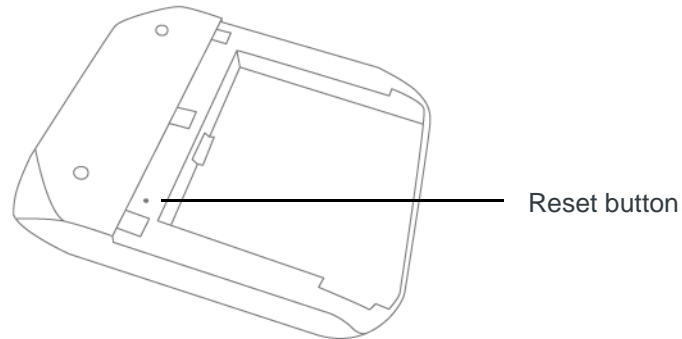

2. Find the small hole below and to the right of the battery compartment. The reset button is inside this hole.

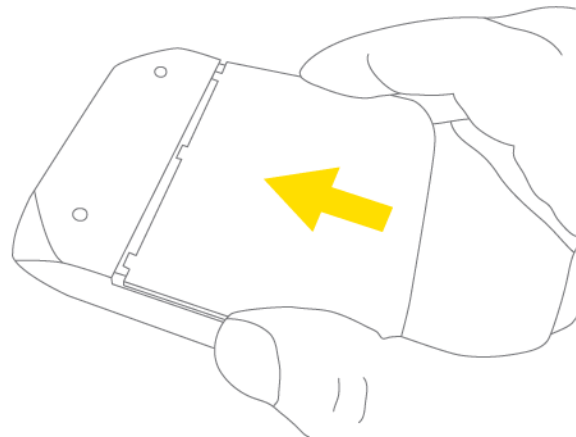

3. Insert a thin object (for example, the end of a paper clip) into the hole, and lightly press on the bottom of the hole **for five or more seconds**.
4. Replace the battery compartment cover.





5. Check the device LCD. If it displays "Reset to factory defaults? Press  to accept", press the power button  on the device.
6. Follow the instructions on the device LCD.

Resetting the Software to Default Settings (Through the Browser Interface)

Warning: If you reset the software to default settings:

- You must go through the device setup ([page 37](#)), as if you've just purchased the device.
 - Any changes you've made to the settings are lost.
- Your 3G and 4G account information is not affected; after reset, the device remains provisioned for service.
-

1. Log in to the home page.
2. Click **Advanced settings** (.
3. Click **Router > Basic**.
4. Click **Router Settings Reset**.

5. Check the device LCD. If it displays "Reset to factory defaults? Press  to accept", press the power button  on the device.
6. Follow the instructions on the device LCD.

Exporting and Importing Settings

Exporting Settings

Settings include configuration information for the device, network, and browser interface.

You can, for example, save the current configuration, then make some changes and test them. You can then use the **Import** button to restore (load) the saved configuration.

To export the settings to a text file:

1. Log in to the home page.
2. Click **Advanced settings** ().
3. Click **Device > Basic**.
4. Click **Export**.

Importing Settings

1. Log in to the home page.
2. Click **Advanced settings** ().
3. Click **Device > Basic**.
4. Browse to and click the file with the previously exported settings.
5. Click **Import**.

Note: Your device may reset, and you may need to reconnect to Wi-Fi and the Internet. See ["How Do I Connect to Wi-Fi?"](#) on page 110 and ["Launching Your Network Connection"](#) on page 51.

Logs

Logs Available

The following types of logs are available:

- Connect/disconnect. See the following section.
- System events. See ["System Events"](#) on page 106.

Connection History

The connection history shows the time of connections to and disconnections from the Internet.

Note: The connection history does not log the amount of data transferred. In the Internet Connection Information window, you can view information on the current billing cycle and lifetime of the device; see "[Internet Connection Information](#)" on page 57.

Enabling and Disabling Logging of Connect/Disconnects

1. Log in to the home page.
2. Click **Advanced settings** ()
3. Click **Device > Log**.
4. In the **Connect/Disconnect** section, select **Enable** or **Disable**.
5. Click **save**.

Exporting the Connection History

1. Log in to the home page.
2. Click **Advanced settings** ()
3. Click **Device > Log**.
4. Ensure **Connection/Disconnect** is set to **Enable**.
5. Click **Export**.

Clearing the Connection History

1. Log in to the home page.
2. Click **Advanced settings** ()
3. Click **Device > Log**.
4. In the **Connect/Disconnect** section, click **Clear log**.

System Events

You can enable or disable, as a group, the logging of the following events:

- Software update available
- Network update available
- Primary WAN failover
- Primary WAN switchback
- Unexpected data connection loss
- Changes to miscellaneous settings

The following system events are always logged:

- Intrusion alerts
- Unexpected power loss
- Critical battery
- Critical temperature
- Routing hardware settings reset
- Firmware update

Enabling and Disabling Logging of System Events

1. Log in to the home page.
2. Click **Advanced settings** ().
3. Click **Device > Log**.
4. In the **Verbose System Event Logging** section, select **Enable** or **Disable**.
5. Click **save**.

Note: Certain events are always logged; see ["System Events"](#) on page 106.

Exporting System Events

1. Log in to the home page.
2. Click **Advanced settings** ().
3. Click **Device > Log**.
4. Ensure **Verbose System Event Logging** is set to **Enable**.
5. Click **Export**.

Clearing the System Events Log

1. Log in to the home page.
2. Click **Advanced settings** ().
3. Click **Device > Log**.
4. Ensure **Verbose System Event Logging** is set to **Enable**.
5. Click **Clear log**.

Setting the Method Used for Time Acquisition

Time information is stored in the connection history log and system events log.

To set the method used for obtaining the time:

1. Log in to the home page.
2. Click **Advanced settings** ().
3. Click **Device > Log**.

4. Select the **3G** or the **NTP** check box.

3G — Time information is obtained from the 3G (CDMA) network; this is more accurate than NTP, but requires 3G coverage.

NTP — The device's clock is synchronized to a Network Time Protocol server on the Internet; not as accurate as when using the **3G** setting, but doesn't require 3G coverage. Use this setting if you have 4G but no 3G coverage.

Setup Pages

Welcome to Your Device Window - Select an Option

The "Welcome to Your Clear Spot 4G+ window" opens:

- Automatically, as part of the initial setup of your newly purchased device.
- When you click **Admin Setup** () from the home page (you must be logged in).

Note: This window displays the administrator password and the address of the device home page. Please remember this information or write it down in a safe place.

This window provides several options.

- To keep the default settings of the device, select one of the following:
 - **The Internet** (to start surfing)
 - **My Clear Spot 4G+'s home page** (to view the device status, customize settings).
- To change security settings, select **Set up my Clear Spot 4G+**.

More Information

Visiting the CLEAR Website

Check www.clear.com/support for product updates and support.

Contacting Customer Service

You can reach CLEAR Customer Service by:

- Visiting www.clear.com/support

Online Help

1. In the browser interface, click the Help button () and, from the menu, select **Online Help**.

The Help system opens in a new Web browser window or tab.

You have several options to find the information you need:

- Browse the Table of Contents.
- Use the Index or Search feature: click the appropriate button in the lower left part of the help window, and type the information you're looking for.

Other Ways to View Help Information

- Some windows have a  icon. Click the icon to view Help information.
- When you move the cursor over a field or button in **Advanced Settings**, help information, if available, appears to the right of the window.

Contextual Help in the Advanced Settings Window

When you move the cursor over a field or button in **Advanced Settings**, help information on this item, if available, appears to the right of the window.



To turn this feature on or off:

1. Ensure you're logged in to the home page.
2. Click **Advanced settings > Device > Basic**.
3. Set **Help for Advanced Settings** to **Show** or **Hide**.
4. Click **Save**.

Frequently Asked Questions

How Can I Tell I'm Connected to 3G/4G?

When you're connected:

- The 3G or 4G icon (on the left side of the home page) is solid. For example, .
- The bottom area of the device LCD, the Virtual Device, and the Mini Window show the data transfer icon  and data transfer information (amount of data; connection duration).

How Do I Connect to Wi-Fi?

You may have to manually connect to Wi-Fi after certain events — for example, as part of the initial device setup, or after a software update.

Tip: *The Wi-Fi network name is displayed on the device LCD.*

1. Do one of the following, depending on your operating system.

Windows

Windows 7: Right-click the  icon in the system tray.

Windows Vista: Click **Control Panel > Network and Internet > Network and Sharing Center > Connect to a network.**

Windows XP: Click **Control Panel > Network Connections > Wireless Network Connections > View available wireless networks.**

Mac

Click the AirPort icon  (in the upper right corner of your screen).

Linux

Please see the user documentation of the Linux distribution.

Other operating systems

Please see the user documentation for your operating system or computer.

2. Select the Wi-Fi network provided by the Clear Spot 4G+ personal hotspot and connect to it. (If prompted for a network key/security key/password, enter the Wi-Fi password.)

What Do I Do if I Forgot the Wi-Fi Password?

- If the Wi-Fi Password Reminder feature is enabled, display the password on the device. See "[Wi-Fi Password Reminder](#)" on page 88.
- Connect the device to your computer through USB, then log in and view the Wi-Fi password (in **Advanced settings > Wi-Fi > Security**). Write the password down in a safe place. See "[Connecting Through USB](#)" on page 30.

Note: If you've forgotten both the Wi-Fi password and the administrator (login) password, then you must reset the software to default settings. See ["Resetting the Software to Default Settings"](#) on page 103.

What Do I Do if I Forgot the Administrator Password?

1. Reset the software to default settings. See ["Resetting the Software to Default Settings"](#) on page 103.
2. Go through the device setup, during which the administrator password will be displayed; write it down in a safe place. See ["Setting Up the Device"](#) on page 37.

How Do I Access My Corporate Network Through a VPN?

1. Establish a connection to the 3G/4G network.
2. Launch the extranet client provided by your company.
3. Supply the appropriate user name and password to gain access.

For support, contact your company help desk.

Are Terminal Sessions Supported?

Terminal sessions (for example, via `telnet` or `ssh`) are not supported.

Tips

Extending Battery Life

- When you're not using the device, turn it off, or end the 3G/4G connection. (Click **Disconnect** on the home page).
- Connect the device, through the USB cable, to the power adapter or a computer, and disable Wi-Fi. See ["Disabling Wi-Fi When Connected Through USB"](#) on page 91.
- Adjust the LCD — do one or more of the following:
 - Turn off the LCD (**Advanced settings > Device > Display > LCD Backlight**).
 - Decrease the brightness of the LCD (**Advanced settings > Device > Display > Backlight Settings > On Battery/USB Power**).
 - Set the LCD to turn off sooner. See ["Setting the LCD Timeout"](#) on page 72.
- Configure the setting (for when battery powered or connected via USB) to "Better battery life" (**Advanced settings > Wi-Fi > Network > Battery or USB powered**).
- Enable standby (low power) mode. See ["Standby \(Low Power\) Mode"](#) on page 56.
- Turn off the lighting of the power button  (i.e. LED) (**Advanced settings > Device > Display > Power Button LED**).

- Limit the number of Wi-Fi users (**Advanced settings > Wi-Fi > Network > Max Number of Users**).
- If you have 3G but not 4G coverage, set **WAN Mode** to "3G only" (**Advanced settings > WAN > Setup > WAN Mode**).

Device Location

- Avoid moisture or extreme temperatures.
- For improved reception, place the device near a closed window.
- Place your device within easy reach of a reliable power supply and the computer to which it will be connected.

Improving Signal Strength

- Ensure you're inside the network coverage area.
- Try reorienting your device.
- Move the device and your computer to another location — you may be in or near a structure that is blocking the signal. Every obstacle (for example, walls, ceilings, furniture) between the Clear Spot 4G+ personal hotspot and other wireless devices decreases the signal strength.
- Place the device in a centralized location, as high as possible in the room.
- Make sure there's plenty of space around your device to provide the best signal reception.
- Keep the device at least 3-6 feet away from electrical devices that generate RF interference (for example, microwaves, TVs, 2.4 GHz cordless phones, cellular phones, baby monitors, wireless speakers). If you're not using these electrical devices, turn them off.
- If possible, place your devices so that the signal passes through open doorways or drywall, as opposed to concrete, brick, metal, walls with insulation, and so on.
- If you cannot obtain service, contact CLEAR — a network or account problem may be preventing you from obtaining service.

Improving 3G Network Service

To improve your network service, periodically check for PRL and profile updates.

The PRL (Preferred Roaming List) is an account configuration item set by your service provider. It controls the radio channels and network carrier used by the 3G modem.

To check for these updates:

1. Log in to the home page.
2. Click **Advanced settings** ().
3. Click **WAN > Setup**.
4. Click **Update 3G PRL**.
5. After the update checking is completed, click **Update 3G Profile**.

Improving Wi-Fi Performance

- Try a different channel number. See "[Wi-Fi Channel](#)" on page 91.
- Check whether any device updates are available. See "[Updates](#)" on page 64.
- See the tips in "[Improving Signal Strength](#)" on page 112.
- Limit the number of Wi-Fi users (**Advanced settings > Wi-Fi > Network > Max Number of Users**).
- Select a longer Wi-Fi range. (**Advanced settings > Wi-Fi > Network > Longer Wi-Fi range** [two locations: **Battery or USB Powered**, and **AC Powered**])

Windows XP Users

1. Open the Device Manager.
 - a. Click **start > Settings > Control Panel**.
 - b. Double-click **System**.
 - c. Click **Hardware**.
 - d. Click **Device Manager**.
2. Double-click **Network adapters**.
3. Double-click the Wi-Fi client network adapter of your computer — for example, "Intel(R) WiFi Link 5100 AGN" in the following screenshot.

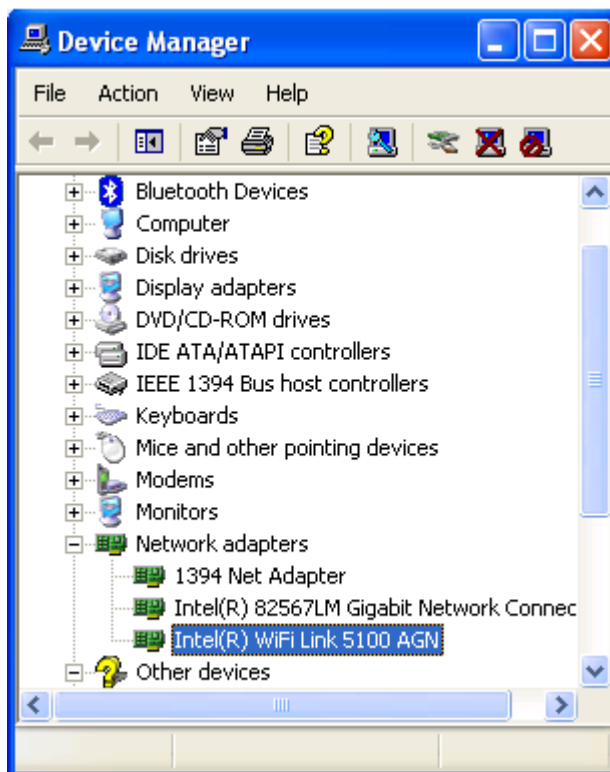

4. If the Wi-Fi client network adapter is by Intel, click **Advanced** and, in the **Property** list, click **Power Management** and move the slider all the way to the right (to **Highest**). Click **OK**.

— or —

If the Wi-Fi client network adapter is not by Intel, select a configuration with minimal power savings (to maximize throughput).

Note: The above settings are often controlled by 3rd-party value-add applications and may be automatically changed. If Wi-Fi performance improves for a while after performing the above steps, but then declines, recheck the above settings.

Security Tips

- Change the Wi-Fi network name (SSID) and Wi-Fi password on a regular basis. See "[SSID \(Wi-Fi Network Name\)](#)" on page 84 and "[Wi-Fi Password](#)" on page 87
- Disable SSID Broadcast. See "[Network Panel](#)" on page 82.
- Use the highest level of Wi-Fi security that your devices support. See "[Wi-Fi Security](#)" on page 86.
- Change the login password. See "[Changing the Administrator Password](#)" on page 75.
- Use MAC filtering to specify computers that are or aren't allowed to connect to the network. See "[MAC Filter Panel](#)" on page 83.

Finding the MAC Address

You'll need to know the MAC address of a device, when performing any of the following:

- Assigning an IP address based on a MAC address (when using DHCP). See "[DHCP Static IP Assignment List](#)" on page 97.
- Allowing or denying computers access to the network. See "[Allowing or Denying Computers Access to the Network](#)" on page 88.

Tip: You can display a list of connected devices, including the MAC address of each device: click **List of connected devices**, available from **Advanced settings > Wi-Fi > MAC Filter** and **Advanced settings > Wi-Fi > Network**.

The steps to finding the MAC address of a device vary, depending on your operating system.

Windows

1. Open a command prompt window.
 - a. Click **start** and **Run**.
 - b. Type **cmd** or **command**, and click **OK**.
2. At the command prompt, type **ipconfig/all** and press **Enter**.
3. Write down the Physical Address for the entry that relates to the wireless network connection; it appears as a series of numbers and letters — this is the MAC address of your wireless adapter.

Mac OS X

1. From the Apple menu () , select **System Preferences**.
2. Select **Network**.
3. Select the adapter that is connecting to the routing hardware.
4. Select **Advanced**.
5. Select **Ethernet**. The Ethernet ID is listed. This is the same as the MAC address.

Linux

Please see the user documentation of the Linux distribution.

Other operating systems

Please see the user documentation for your operating system or computer.

Finding the IP Address

You'll need to know the IP address of a device, when configuring any of the following:

- Port forwarding
- Port triggering
- DMZ
- Static DHCP features

To find the IP address of a device:

Windows

1. Open a command prompt window.
 - a. Click **start** and **Run**.
 - b. Type **cmd** or **command**, and click **OK**.
2. At the command prompt, type **ipconfig** and press **Enter**.
3. Write down the IP Address for the entry that relates to the wireless network connection. (The IP address might be listed under "Ipv4 Address", or something similar.)

Mac OS X

1. From the Apple menu () , select **System Preferences**.
2. Select **Network**.
3. Select the wireless adapter. The IP address is displayed in the right pane.

Other operating systems

Please see the user documentation for your operating system or computer.



Troubleshooting Tips

General tips

- Check the system events log. See "[Exporting System Events](#)" on page 107.
- If some settings are preventing you from connecting to Wi-Fi, connect to the device through the USB cable, and then change the settings. See "[Requirements for a USB Tethered Connection](#)" on page 43 and "[Making a Tethered Connection](#)" on page 43.
- Go to www.clear.com/support to access troubleshooting and other resources.
- The knowledge base at the Sierra Wireless website (www.sierrawireless.com/support/customer_help.aspx) may also be useful.

LCD Is Dark

The LCD is dark and is not displaying any text or icons if:

- The device is turned on and:
 - The LCD is turned off (**Advanced settings > Device > Display > LCD Backlight**).
 - The LCD is turned on, but the LCD is dormant (inactivity timeout). To make the LCD active, briefly press the power button  on the device.
 - The device is in standby (low power) mode. To exit this mode, briefly press the power button  on the device.
- The device is turned off.

To turn the device on:

 - a. Ensure a battery is inserted into the device.
 - b. Press the power button  on the device for approximately two seconds.

If the LCD is still dark, use the USB cable to connect the device to the power adapter or to a computer.

Insufficient Signal Strength

If you have insufficient signal strength, the icon  is displayed (on the left side of the home page).

Insufficient signal strength may occur because:

- You are outside the network coverage area.
- Your device's internal antenna is pointing in the wrong direction.
- You are in or near a structure that is blocking the signal.
- You are near a device that is causing radio signal interference.
- A network or account problem is preventing you from obtaining service.

See also "[Improving Signal Strength](#)" on page 112.

Messages Displayed on the Device LCD

See also ["SD Card Error"](#) on page 49.

3G Activation Failed

If this message is displayed on the device LCD or in the 3G Activation Required alert window (after you've attempted activation):

1. Ensure you're in 3G coverage and the signal strength is strong.
2. Turn the device off and on. See ["Turning Your Device Off"](#) on page 48 and ["Turning Your Device On"](#) on page 33.
3. If the "Activation failed" message is still displayed, prepare the following, and contact CLEAR:
 - Your billing information.
 - ESN of the device (displayed on the packaging, on the device [under the battery], and at **Advanced settings > Device > About**).

Connecting to 3G/4G

If the LCD displays this message for a long time:

1. Check the signal strength. If it is weak, try the tips in ["Improving Signal Strength"](#) on page 112.
2. Try a different Connection Preferences setting. See ["Mobile Broadband Information and Settings"](#) on page 53.
3. Turn the device off and on. See ["Turning Your Device Off"](#) on page 48 and ["Turning Your Device On"](#) on page 33.
4. Update the 3G profile: click **Advanced settings > WAN > Setup > Update 3G Profile**.
5. If you're still unable to connect to 3G/4G, contact CLEAR.

Connection Error



If this message persists on the device LCD, update the 3G profile:

1. Log in to the home page.
2. Click **Advanced settings** (.
3. Click **WAN > Setup**.
4. Click **Update 3G Profile**.
5. If an error message and number are displayed on the LCD after the update, note the information and contact CLEAR.

3G Activation Required

If the LCD displays this message, display the 3G Activation Required alert and start the activation:

1. In the **Admin Login** section (in the upper left area of the home page), enter the administrator password (1–20 characters/numbers). (The default password is "admin".)
2. Click **OK**.

3. Click the alerts icon  to display the alert window.
4. If more than one alert is available, use the  and  buttons (at the top of the alert window) to browse to the "3G Activation Required" alert.
5. In the 3G Activation Required alert window, click **Activate now**.

Tip: Alternatively, click **Advanced settings > WAN > Setup > Update 3G Profile**.

Searching for Network

The LCD displays this message until a 3G or 4G network is acquired.

If this message persists, see the tips in "[Cannot Connect to the 3G/4G Network](#)" on page 120.

Update Failed

If this message appears on the device LCD or in the 3G Network Update Available or Software Update Available alert windows (after you've attempted the update):

1. Ensure your device is connected to the power adapter or computer, through the USB cable.

Note: If you'll be using USB for data transfer (and not just for charging the device), you must install the device driver. See "[Making a Tethered Connection](#)" on page 43.

2. Retry the update.
3. If the "Update failed" message is still displayed, contact CLEAR.

Cannot Connect to Wi-Fi

If your computer cannot connect to the Wi-Fi network of the Clear Spot 4G+ personal hotspot, ensure that:

- The maximum number of Wi-Fi users has not been reached. (To determine the number of connected Wi-Fi users and set the maximum, see "[Wi-Fi Users Information and Settings](#)" on page 55).
- You're connecting to the correct Wi-Fi network (SSID), and you're using the correct Wi-Fi password. If the Wi-Fi Password Reminder feature is enabled ([page 88](#)), you can use it to display the SSID and Wi-Fi password on the device LCD.
- Nobody has changed the name or password of the Wi-Fi network. If the Wi-Fi Password Reminder feature is enabled ([page 88](#)), you can use it to display the SSID and Wi-Fi password on the device LCD.
- Nobody is connected through the USB cable when **Disable Wi-Fi when connected via USB** is selected.
- Your computer supports the type of Wi-Fi security that the network is set to use.

Note: All the devices used with the Clear Spot 4G+ personal hotspot must support the selected security type.

- Your computer supports Wi-Fi 802.11g (if **Basic Rate** is set, in **Advanced settings > Wi-Fi > Network**, to **802.11b/g compatibility**).
 - Your computer has not been blocked, through MAC filtering. See "[Specifying Computers That Are Not Allowed to Access the Network](#)" on page 89.
-

Tip: *If some settings are preventing you from connecting to Wi-Fi, connect to the device through the USB cable, and then change the settings. See "[Requirements for a USB Tethered Connection](#)" on page 43 and "[Making a Tethered Connection](#)" on page 43.*

Cannot Display the Home Page

Your Web browser may display an error message when you try to display the home page. The error message depends on your Web browser.

- "Could not connect to remote server" (Opera)
- "Internet Explorer cannot display the webpage" (Internet Explorer)
- "Oops! This link appears to be broken" (Google Chrome)
- "Safari can't open the page" (Safari)
- "The connection has timed out" (FireFox)

Check the following:

- The device is turned on. See "[Turning Your Device On](#)" on page 33.
- You have established a connection to the device (through Wi-Fi or through the USB cable).
- Ensure you're typing the correct address in the Web browser.
 - Try **http://<SSID>**, where <SSID> is as displayed on the device LCD.
 - If the home page is still not displayed, try **http://192.168.0.1** or, if you're using custom routing settings, replace "192.168.0.1" with the appropriate IP address.
- The Web browser is a recent version, and Java-enabled. The following are recommended:
 - Internet Explorer (version 6.0 or higher)
 - Mozilla Firefox (version 2.0 or higher)
 - Google Chrome (version 2.0.172.28 or higher)
 - Apple Safari (version 2.0 or higher)
 - Opera version 9.64
- If your computer has other adapters (for example, Ethernet) connected to other networks, disable or remove them from your computer.
- If Internet security software is running on your computer, disable it and see whether the error message still occurs. Some firewall software may block access to the home page.
- If DHCP is enabled on the device, ensure DHCP is enabled on your computer. See "[DHCP](#)" on page 96.

- Check your Web browser settings.
 - a. Open the Control Panel in Windows.
 - b. Double-click **Internet Options**.
 - c. From the **Security** tab, restore the default settings.
 - d. From the **Connections** tab, select **Never dial a connection**.
 - e. From the **Advanced** tab, restore the default settings.
 - f. Close and reopen your Web browser.
- Disconnect the device from your computer (if you're using the USB cable). Remove the battery from the device. Reinsert the battery.

If, after checking all of the above, you still cannot display the home page, consider resetting the software to default settings. See ["Resetting the Software to Default Settings"](#) on page 103.

Cannot Connect to the 3G/4G Network

- Ensure your computer is connected to the device (through the USB cable or Wi-Fi). See ["How Do I Connect to Wi-Fi?"](#) on page 110 or ["Making a Tethered Connection"](#) on page 43.
- Try the tips in ["Improving Signal Strength"](#) on page 112.
- Check the **WAN Mode** setting (**Advanced settings > WAN > Setup**). For example, if it's set to **4G only**, you won't be able to connect if:
 - You don't have 4G coverage.
- Check with CLEAR — a network or account problem may be preventing your device from obtaining service.

Cannot Check for Updates

Ensure your device is connected to the power adapter or computer, through the USB cable.

Note: If you'll be using USB for data transfer (and not just for charging the device), you must install the device driver. See ["Making a Tethered Connection"](#) on page 43.

Sounds are Enabled, but the Device Doesn't Generate Any Sounds

Check that sounds are not turned off through the Mute switch on the device. See ["Mute Switch"](#) on page 36.



7: Technical Specifications, Safety Information, and Regulatory Information

Technical Specifications

LED Operation

See ["Using the Power Button to Determine the Device State"](#) on page 34.

Radio Frequency and Electrical Specifications

Approvals	FCC
Battery	Size: 1800 mAh Duration for full charge: <ul style="list-style-type: none">• AC charger: 1.5 hours• PC USB cable: 3.6 hours Charge life: <ul style="list-style-type: none">• 4 hours under standard use• 3 hours of continuous use
Current	Maximum: 1000 mA Standby: <ul style="list-style-type: none">• 48 mA (1xEV-DO/IS2000 hybrid mode)• 48 (WiMAX)
Transmit	PCS: 1850 to 1910 MHz Cellular: 824 to 849 MHz WiMAX: 2495 to 2690 MHz
Receive	PCS: 1930 to 1990 MHz Cellular: 869 to 894 MHz WiMAX: 2495 to 2690 MHz GPS: 1575.42 MHz

Software Specifications

CDMA (3G) specification	IS-2000 Release 0
Data service	IS-707A
WiMAX (4G) specification	IEEE 802.16e-2005
Wi-Fi specification	IEEE 802.11b IEEE 802.11g
Wi-Fi security and encryption protocols	WEP Open & Shared WEP-64 WEP-128 WPA-Personal TKIP & AES (Pre-Shared Key or WPA-PSK) WPA2-Personal TKIP & AES (WPA2-PSK) WPA+WPA2-Personal (WPA+WPA2 PSK)
SMS (IS-637)	Not supported
FAX	Not supported
IOTA	Supported
OTASP (IS-683A, IS-683B, IS-683C)	Supported
OTAPA	Supported
PRL (Preferred Roaming List)	Supported
Authentication	Supported
Voice	Not supported
NAM	Single
Position Location	Standalone
TTY/Accessibility	Not supported
Mobile IP	Supported
Network protocols (routing hardware)	TCP, UDP, ARP, RARP, ICMP
VPN	Pass-through of the following VPN types: <ul style="list-style-type: none"> • PPTP • IPSec Tunneling of multiple VPN sessions simultaneously is supported.

Environmental Specifications

Operating temperature	-20 to +55°C
Storage temperature	-40 to +85°C
Humidity	95%, non-condensing
Vibration	10-1000 Hz, 6G, 60 min/axis, 3 hrs total (non-operating)
Drop	1 m on concrete

Mechanical Specifications

Dimensions (W x L x H)	81 mm x 81 mm x 16 mm
Power button	Supported
Headset jack	Not supported
LED	White

Safety Information

Proper Battery Use and Disposal

Note: Improper battery use may result in a fire, explosion, or other hazard.

To ensure safe and responsible battery use:

- Do not open, disassemble, puncture, crush, bend, or shred.
- Do not expose to water or other liquids, fire, explosion, or other hazards.
- Use the battery only in the Clear Spot 4G+ personal hotspot.
- If using with a charger, use only the power adapter supplied with the device.
- Do not short circuit the battery.
- When replacing a battery, use the same model of battery that was supplied with the device.
- Follow local regulations when disposing of a used battery.
- Avoid dropping the device or the battery. If dropped and you suspect damage, take it to a service center for inspection.

Regulatory Notices

The design of the Clear Spot 4G+ personal hotspot complies with U.S. Federal Communications Commission (FCC) guidelines respecting safety levels of radio frequency (RF) exposure for mobile devices, which in turn are consistent with the following safety standards previously set by U.S. and international standards bodies:

- ANSI / IEEE C95.1-1999, *IEEE Standard for Safety Levels with Respect to Human Exposure to Radio Frequency Electromagnetic Fields, 3kHz to 300 GHz*
- National Council on Radiation Protection and Measurements (NCRP) Report 86, 1986, *Biological Effects and Exposure Criteria for Radio Frequency Electromagnetic Fields*
- International Commission on Non-Ionising Radiation Protection (ICNIRP) 1998, *Guidelines for limiting exposure to time-varying electric, magnetic, and electromagnetic fields (up to 300 GHz)*

FCC ID: N7N-MHS801.

RF Exposure - This device is only authorized for use in a mobile application. At least 20 cm (8 inches) of separation distance between the Clear Spot 4G+ personal hotspot and the user's body must be maintained at all times.

Warning: (EMI) - United States FCC Information - *This equipment has been tested and found to comply with the limits for a Class B computing device peripheral, pursuant to Parts 15 and 27 of the FCC rules. These limits are designed to provide reasonable protection against harmful interference in a residential installation.*

This equipment generates, uses, and can radiate radio frequency energy and, if not installed and used in accordance with the instructions, may cause harmful interference to radio communications. However, there is no guarantee that interference will not occur in a particular installation.

If this equipment does cause harmful interference to radio or television reception, which can be determined by turning the equipment off and on, the user is encouraged to try to correct the interference by one or more of the following measures:

- Reorient or relocate the receiving antenna.
- Increase the separation between the equipment and receiver.
- Connect the equipment into an outlet on a circuit different from that to which the receiver is connected.
- Consult the dealer or an experienced radio/TV technician for help.

This device complies with Parts 15 and 27 of the FCC Rules. Operation is subject to the condition that this device does not cause harmful interference.

Index

Numerics

- 3G
 - 3G panel of the WAN tab [92](#)
 - activation failed [117](#)
 - activation information, viewing [91](#)
 - activation, initiate [48](#)
 - configuration, resetting to default settings [92](#)
 - data transmission rates [26](#)
 - improving network service, tips [112](#)
 - lifetime data [80](#)
 - Mobile Broadband Information window [53](#)
 - overview [26](#)
 - PRL version [67](#), [79](#), [92](#)
 - service type [92](#)
 - status [92](#)
- 3G (time acquisition method) [108](#)
- 3G Activation Required (alert) [48](#)
- 3G Activation Required (LCD message) [117](#)
- 3G Network Update Available (alert) [49](#)
- 3G Only [54](#), [80](#)
- 3G panel of the WAN tab [92](#)
- 3G/4G Mobile Broadband Information window [53](#)
- 3G/4G Off [54](#), [80](#)
- 4G
 - 4G panel of the WAN tab [81](#)
 - Base Station ID (BSID) [81](#)
 - configuration, resetting to default settings [92](#)
 - connection status [81](#)
 - coverage type (service type) [81](#)
 - data transmission rates [26](#)
 - lifetime data [80](#)
 - Mobile Broadband Information window [53](#)
 - network access provider (NAP-ID) [81](#)
 - network service provider (NSP-ID) [81](#)
 - overview [26](#)
- 4G Only [54](#), [80](#)
- 4G Preferred [54](#), [80](#)
- 802.11 standards supported [122](#)

A

- About panel of the Device tab [78](#)
- about this guide [27](#)
- AC charger (power adapter) [32](#)
- AC powered [56](#), [71](#)
- access to the network, configuring [88](#), [89](#)
- account information [67](#), [79](#)
- acquisition, time, method used for [107](#)
- Activate now [41](#)
- activating network service [40](#)
- Activation complete! [49](#)
- Activation Date [67](#), [79](#)
- Activation Required (alert) [48](#)
- Activation Status [67](#), [78](#)
- activation, 3G
 - 3G Activation Required [117](#)
 - 3G Activation Required alert [48](#)
 - date of original activation [91](#)
 - failed [117](#)
 - initiate [48](#)
- Active network [53](#), [80](#)
- Admin Login area of the home page [46](#)
- Admin Password [75](#)
- Admin Setup button [59](#)
- Administrator + Guest [61](#)
- administrator password
 - changing [75](#)
 - forgotten; what do I do? [111](#)
- administrator, logging in as [46](#)
- Advanced Settings window [59](#), [76](#)
- AES [40](#), [86](#)
- alert
 - 3G Activation Required [48](#)
 - Alert window [54](#)
 - audio, enabling/disabling [73](#)
 - critical battery level alert [74](#)
 - displaying [48](#)
 - low battery [74](#)
 - Network Update Available [49](#)
 - SD Card Error [49](#)
 - Software Update Available [50](#)
 - Sounds panel of the Device tab [77](#)
- Alert when (low battery) [74](#)
- Alert window [54](#)
- Allow all in list (giving computers access to the network) [88](#)

- allowing computers access to the network [88](#)
- Apple Safari [28](#)
- Application (port forwarding) [99](#)
- application notes [17](#)
- application updates [64](#)
- automatically check for updates [64](#)
- automatically log in
 - disabling for a specific computer [75](#)
 - enabling [75](#)
 - viewing list of computers set to automatically log in [75](#)

B

- baby monitors [112](#)
- Backlight (LCD on the device)
 - brightness [72](#)
 - turning off automatically [72](#)
 - turning on or off [72](#)
- Backlight Settings [72](#)
- Base Station ID (BSID) [81](#)
- Basic panel of the Device tab [76](#)
- Basic panel of the Router tab [93](#)
- Basic Rate [83](#)
- battery
 - "Better battery life" setting [56](#), [71](#), [82](#)
 - Battery Information and Settings window [56](#)
 - charging [31](#)
 - critical battery level alert [73](#), [74](#)
 - icon [56](#)
 - installing [29](#)
 - low battery alert [74](#)
 - low battery, play sound [58](#)
 - overview [29](#)
 - proper use and disposal [123](#)
 - specifications [121](#)
 - tips on extending battery life [111](#)
- Battery Information and Settings window [56](#)
- Battery or USB powered [56](#), [71](#)
- Better battery life [56](#), [71](#), [82](#)
- billing cycle
 - data statistics [57](#)
- blacklist [83](#), [88](#)
- Block (block a computer's access to the Wi-Fi network of the device) [55](#)
- Block all in list [88](#), [89](#)
- box contents [27](#)
- brightness of LCD [72](#)

- broadcast the SSID (Wi-Fi network name) [82](#)
- browser interface home page
 - See home page
- browser interface updates [64](#)
- browsers supported [28](#)
- BSID (Base Station ID) [81](#)
- buttons
 - below the virtual device [60](#)
 - top of home page [59](#)

C

- cannot connect to the 3G/4G network [120](#)
- cannot connect to Wi-Fi [118](#)
- cannot display the home page [119](#)
- care of your device [27](#)
- Carrier to Interference-plus-Noise Ratio (CINR) [53](#)
- CDMA
 - See 3G
- cell phones [112](#)
- Center frequency [81](#)
- Certificate information [82](#)
- charger (power adapter) [32](#)
- charging the device [31](#)
- check for updates
 - automatically [64](#)
 - manually [65](#)
- Check for updates now [65](#)
- Chrome browser [28](#)
- CINR (Carrier to Interference-plus-Noise Ratio) [53](#)
- Clear Log (connection history) [106](#)
- Clear Log (system events) [107](#)
- components of your device [26](#)
- Connect Automatically [54](#)
- Connect button [60](#)
- connect to Internet
 - alert [73](#), [78](#)
 - cannot connect [120](#)
 - improving 3G network service, tips [112](#)
 - launching a connection [51](#)
 - sharing your connection [51](#)
- Connect/Disconnect [106](#)
- connected
 - how to tell you're connected to 3G/4G [110](#)
 - icon [53](#)
 - play sound when connected or disconnected [58](#)
 - Wi-Fi users information [55](#)

- connected computers, displaying a list of [90](#)
 - Connected Users window [55](#)
 - connecting the device to your computer
 - USB [43](#)
 - Wi-Fi [110](#)
 - Connecting to 3G/4G message [117](#)
 - connection
 - ending [51](#)
 - history log [106](#)
 - improving 3G network service, tips [112](#)
 - information, displaying [57](#)
 - launching [51](#)
 - lost (audio alert) - Internet Disconnected [73](#)
 - settings [54](#), [80](#)
 - sharing [51](#)
 - state [53](#), [81](#)
 - status, 3G [53](#)
 - status, 4G [53](#), [81](#)
 - Wi-Fi users information [55](#)
 - Connection Error message [117](#)
 - connection history
 - clearing [106](#)
 - description [106](#)
 - enabling logging [106](#)
 - exporting [106](#)
 - Connection Preferences [54](#)
 - contents, package [27](#)
 - contextual (field-level) Help [109](#)
 - cordless phones [112](#)
 - corporate network, accessing through VPN [111](#)
 - Could not connect to remote server [119](#)
 - coverage type (service type)
 - 3G [92](#)
 - 4G [81](#)
 - coverage type(s) available [53](#), [92](#)
 - critical battery level alert [74](#)
 - critical temperature alert [73](#)
 - current, electrical (specification) [121](#)
 - Customer Service, contacting [109](#)
- D**
- dark LCD [116](#)
 - data statistics for the current connection session [57](#)
 - data transferred [57](#), [80](#)
 - data transmission rates [26](#)
 - default settings
 - 3G/4G configuration, resetting [92](#)
 - software, resetting [104](#)
 - software, resetting (through the reset button on the device) [103](#)
 - denying computers access to your network [89](#)
 - Destination IP Address [102](#)
 - device
 - information, viewing [66](#), [78](#)
 - name (host name) [85](#)
 - overview [25](#)
 - device driver, installing [44](#)
 - device name (host name) [90](#)
 - Device tab
 - About panel [78](#)
 - Basic panel [76](#)
 - Display panel [77](#)
 - Log panel [80](#)
 - microSD card panel [77](#)
 - Sounds panel [77](#)
 - DHCP
 - clients, maximum number of [96](#)
 - description [96](#)
 - enabling [96](#)
 - lease time [96](#)
 - start and end address [96](#)
 - Static IP Assignment List [97](#)
 - DHCP IP Address Range [95](#), [96](#)
 - DHCP Lease Time [96](#)
 - DHCP Server [95](#)
 - DHCP Static IP Assignment List [97](#)
 - dimensions of device [123](#)
 - Disable Wi-Fi upon USB-PC [91](#)
 - Disable Wi-Fi when connected via USB [55](#), [91](#)
 - Disconnect button [60](#)
 - Display panel of the Device tab [77](#)
 - displaying
 - home page [46](#)
 - disposal of battery [123](#)
 - DMZ
 - configuring [102](#)
 - DMZ panel of the Router tab [102](#)
 - enabling [102](#)
 - DMZ panel of the Router tab [102](#)
 - DNS Mode [98](#)
 - DNS Relay [95](#)
 - document overview [27](#)
 - dormant [92](#)
 - download speeds [26](#)
 - drawing of hardware [29](#)

driver, installing [44](#)
drop specification [123](#)
duration for full charge [121](#)
duration, session [57](#), [80](#)

E

Ec/lo [53](#), [92](#)
electrical specifications [121](#)
Electronic Serial Number (ESN) [67](#), [79](#)
email server, accessing [98](#)
Enable SD Card [61](#)
End (port, for port forwarding) [99](#)
environmental specifications [123](#)
ESN (Electronic Serial Number) [67](#), [79](#)
Export Router Settings [105](#)
exporting
 connection history [106](#)
 settings [105](#)
 system event log [107](#)

F

Failover wait time [81](#)
failure, device startup
 audio alert [73](#)
FAQ (Frequently Asked Questions) [110](#)
FCC (regulatory) notices [124](#)
FCC ID [124](#)
feedback [60](#)
field-level (contextual) Help [109](#)
Firefox browser [28](#)
firewall software [119](#)
firmware version
 3G modem [67](#), [79](#)
 4G modem [67](#), [79](#)
 routing hardware component [67](#), [78](#)
 Wi-Fi [67](#), [79](#)
firmware, upgrade from a file [65](#)
folder name, microSD card [61](#)
forgot administrator password [111](#)
forgot Wi-Fi password [110](#)
Forward Ports [101](#)
Fragmentation Threshold [83](#)
frequencies, transmit and receive [121](#)
Frequently Asked Questions (FAQ) [110](#)
FTP server, accessing [98](#)
full charge [121](#)

G

gaming, Internet [100](#)
Get Started guide [27](#)
Google Chrome [28](#)
Guaranteed Update [64](#)
Guest Password (for microSD card access) [61](#)
Guest Username (for microSD card access) [61](#)

H

hardware [29](#)
Help button [60](#)
Help files, updates [64](#)
Help for Advanced Settings [109](#)
help, getting
 CLEAR website [109](#)
 Customer Service, contacting [109](#)
 FAQ (Frequently Asked Questions) [110](#)
 tips [111](#)
 troubleshooting [116](#)
Help, online [109](#)
home page
 buttons along the top [59](#)
 cannot display [119](#)
 description [44](#)
 displaying [46](#)
 logging in [46](#)
 vertical row of icons and text [52](#)
 virtual device [47](#)
host name [85](#), [90](#)
humidity specification [123](#)

I

icons
 home page (vertical row of icons and text) [52](#)
 LCD [35](#)
Import Router Settings [105](#)
important information booklet [60](#)
importing settings [105](#)
improving signal strength [112](#)
IMSI (International Mobile Station Identity) [67](#), [79](#),
[92](#)
information about your device [66](#), [78](#)
installing the device [37](#)
International Mobile Station Identity (IMSI) [67](#), [79](#),

-
- 92
 - Internet Connected 58, 73, 78
 - Internet Connection Information window 57
 - connection
 - lost (alert) 73, 78
 - Internet Disconnected 58, 73, 78
 - Internet Explorer 28
 - Internet Explorer cannot display the webpage 119
 - Internet gaming 100
 - Internet telephony 100
 - IOTA 122
 - IP address
 - assigning, based on MAC address 97
 - DHCP, range 95
 - DMZ computer 102
 - finding for a device 115
 - removing an address based on MAC address 97
 - routing hardware 94
 - WWAN, of the device 57
 - IP Address (port forwarding) 99
- K**
- knowledge base 116
- L**
- LAN panel of the Router tab 94
 - Last user has joined 58
 - Last User Has Left 73, 78
 - LCD
 - brightness 72
 - dark 116
 - icons on LCD 35
 - not lit 116
 - timeout 72
 - turning off automatically 72
 - turning on or off 71
 - LCD Backlight 72
 - lease time, DHCP 96
 - LED (Power button on the device)
 - description 34
 - enabling 72
 - interpreting 34
 - location 29
 - lifetime data 80
 - lifetime of product
 - total data transferred 80
 - Link SSID and Host Name 85
 - list of connected computers, displaying 90
 - List of connected devices 90
 - Load 3G PRL 92
 - log
 - connection history 106
 - system events 106, 107
 - log in automatically
 - disabling for a specific computer 75
 - enabling 75
 - viewing list of computers set to automatically log in 75
 - Log panel of the Device tab 80
 - logging in
 - automatically 75
 - steps to log in 46
 - login password
 - changing 75
 - forgotten; what do I do? 111
 - Longer Wi-Fi range 56, 71, 82
 - Low battery 58, 73, 78
 - low battery alert 74
 - low power mode (Standby Timer) 56
- M**
- MAC (Media Access Control) filter 83, 88
 - MAC address
 - 4G modem 67, 79
 - assigning an IP address based on MAC address 97
 - finding for a device 114
 - Wi-Fi users 55
 - Mac device driver, installing 44
 - MAC filter 89
 - MAC Filter List 88, 89
 - MAC filter mode 84, 88
 - MAC Filter panel of the Wi-Fi tab 83
 - maintenance of your device 27
 - manufacturer information 67, 78
 - Max DHCP clients 96
 - Max Number of Users 90
 - Max number of Wi-Fi users 90
 - Max Wi-Fi users 55
 - maximum number of Wi-Fi users 90
 - mechanical specifications 123
-

Media Access Control
See MAC address

MEID (Mobile Equipment Identifier) [67](#), [79](#)

microSD card

- accessing [61](#), [63](#)
- enabling [61](#)
- inserting [62](#)
- location of slot [29](#), [36](#)
- microSD Card panel of the Device tab [77](#)
- overview [36](#)
- removing from the device [62](#)
- SD Card Error (alert) [49](#)
- SD Card Information and Settings window [57](#)
- shared folder name [61](#)

microSD Shared Folder Name [61](#)

microwaves [112](#)

Mini Window [47](#)

Mobile Broadband Information window [53](#)

Mobile Equipment Identifier (MEID) [67](#), [79](#)

Mobile Station ID (MSID) [67](#), [79](#), [92](#)

model information [67](#), [78](#)

Mozilla Firefox [28](#)

MSID (Mobile Station ID) [67](#), [79](#), [92](#)

mute switch, location [36](#)

N

NAI (Network Access Identifier) [92](#)

NAP-ID (Network Access Provider ID) [81](#)

network

- 3G, overview [26](#)
- 4G Base Station ID (BSID) [81](#)
- 4G network access provider (NAP-ID) [81](#)
- 4G service provider (NSP-ID) [81](#)
- 4G, overview [26](#)
- active network [53](#), [80](#)
- cannot connect [120](#)
- name, Wi-Fi (SSID) [84](#)
- network operator [80](#)
- protocols supported [122](#)

Network Access Identifier (NAI) [92](#)

network access provider, 4G (NAP-ID) [81](#)

network access, configuring [88](#)

network operator

- 4G (NSP-ID) [81](#)
- viewing [67](#), [79](#), [91](#)

Network panel of the Wi-Fi tab [82](#)

network service

3G, tips on improving service [112](#)

- activating [40](#)

Network Time Protocol (NTP) [108](#)

Network Update Available (alert) [49](#), [58](#)

network, corporate, accessing through VPN [111](#)

No filtering [88](#)

no service

- icon [53](#)

not connected [53](#)

notices

- regulatory [124](#)

NSP-ID (Network Service Provider ID) [81](#)

NTP (Network Time Protocol) [108](#)

O

Obtain an IP address automatically [96](#)

On AC Power [72](#), [77](#)

On Battery/USB Power [72](#)

online games [98](#), [100](#)

online Help

- displaying [109](#)
- getting updates [64](#)

Oops! This link appears to be broken [119](#)

Opera browser [28](#)

operating temperature [123](#)

operator, network [67](#), [79](#), [91](#)

original activation date [91](#)

OTAPA [122](#)

OTASP [122](#)

overview of this document [27](#)

P

package contents [27](#)

password reminder, Wi-Fi [88](#)

password, administrator

- changing [75](#)
- forgotten; what do I do? [111](#)

password, Wi-Fi

- changing [87](#)
- forgotten; what do I do? [110](#)
- overview [87](#)
- reminder [88](#)

pay-as-you-go [93](#)

performance, Wi-Fi, tips on improving [113](#)

place for your device, tips [112](#)

Plug and Play, Universal (UPnP) [94](#)

Port Forward panel of the Router tab [98](#)
port forwarding
 description [98](#)
 disabling for an application [99](#)
 enabling [99](#)
 enabling for an application [99](#)
Port Trigger panel of the Router tab [100, 101](#)
port triggering
 description [100](#)
 enabling [100](#)
 ports, adding [100](#)
 ports, removing [101](#)
power adapter [32](#)
Power button (on the device)
 description [34](#)
 interpreting [34](#)
 location [29](#)
Power Button LED field [72](#)
Power Off button [48, 60](#)
power settings
 AC outlet, connected to [71](#)
 battery-powered [71](#)
 tips on extending battery life [111](#)
 USB powered [71](#)
powering the device off [48](#)
powering the device on [33](#)
Preable [82](#)
Preferred Roaming List (PRL) update
 See PRL update
PRI version
 3G component [67, 79](#)
 routing hardware [67, 79](#)
PRL update
 alert (update available) [49](#)
 load a file [92](#)
PRL version
 3G modem [67, 79, 92](#)
problems
 See troubleshooting
Protocol (port forwarding) [99](#)
Protocol (port triggering) [101](#)
protocols, network, supported [122](#)

Q

questions, frequently asked (FAQ) [110](#)

R

radio frequency (RF) specifications [121](#)
Realm [82](#)
receive frequencies [121](#)
Received (amount of data transferred) [57](#)
recharging the battery [31](#)
regulatory notices [124](#)
Remember me [75](#)
Remember me clients list [75](#)
Remember me computers, view list of [75](#)
reminder, Wi-Fi password [88](#)
Remote Desktop, accessing [98](#)
requirements
 installation [28](#)
 USB [43](#)
reset button
 location [68](#)
 resetting the software to default settings [103](#)
Reset Device to Factory Defaults button [92](#)
resetting the 3G/4G configuration to default settings [92](#)
resetting the software to default settings
 through the browser interface [104](#)
 through the reset button on the device [103](#)
restarting the device [68](#)
Restriction field [103](#)
RF (Radio Frequency) specifications [121](#)
router
 See routing hardware
Router IP Address [94](#)
Router PRI Version [67, 79](#)
Router setting reset
 audio alert [58, 73](#)
 performing [104](#)
Router tab
 DMZ panel [102](#)
 LAN panel [94](#)
 Port Forward panel [98](#)
 Port Trigger panel [100, 101](#)
routing hardware
 firmware version [67, 78](#)
 IP address [94](#)
 play sound when routing hardware resets [73](#)
 PRI version [67, 79](#)
 resetting to default settings (through the reset button on the device) [103](#)
 resetting to default settings (through the software) [104](#)

- subnet mask [94](#)
- RSSI (signal strength)
 - improving [112](#)
 - insufficient [116](#)
 - viewing [53](#)
- RTS Threshold [83](#)
- Rx (receive) frequencies [121](#)

S

- Safari browser [28](#)
- Safari can't open the page [119](#)
- SD Card error (alert) [49](#)
- SD Card Information and Settings window [57](#)
- Searching for Network [118](#)
- security
 - MAC filtering [83](#)
 - network access, configuring [88](#)
 - SPI (Stateful Packet Inspection) [94](#)
 - tips [114](#)
 - Wi-Fi [86](#)
- Security panel of the Wi-Fi tab [83](#)
- Sent (amount of data transferred) [57](#)
- server, accessing [98](#)
- service icon [53](#)
- Service Programming Code (SPC) [93](#)
- service type
 - 3G [92](#)
- session duration [57](#), [80](#)
- Session total data [80](#)
- Set Guest Password (for microSD card access) [61](#)
- Set Guest Username (for microSD card access) [61](#)
- Set up my device [38](#)
- setting up the device [37](#)
- settings
 - exporting [105](#)
 - importing [105](#)
- Setup panel of the WAN tab [80](#)
- shared folder name, microSD card [61](#)
- sharing your Internet connection [51](#)
- short text messaging (SMS) [122](#)
- Shorter Wi-Fi range [56](#), [71](#), [82](#)
- SID (System ID) [92](#)
- Sierra Wireless
 - knowledge base [116](#)
- Signal Quality window [53](#)
- signal strength

- improving [112](#)
- insufficient [116](#)
- viewing [53](#)
- size of device [123](#)
- SMS [122](#)
- software
 - resetting to default settings [103](#)
 - specifications [122](#)
 - updates [64](#)
- Software Update Available (alert) [50](#), [58](#)
- Software Version [67](#), [78](#)
- sounds
 - enabling/disabling all (Mute switch) [36](#)
 - enabling/disabling individually [73](#)
- Sounds panel of the Device tab [77](#)
- Sounds window [58](#)
- Source IP Address [102](#)
- SPC (Service Programming Code) [93](#)
- specifications
 - electrical [121](#)
 - environmental [123](#)
 - mechanical [123](#)
 - radio frequency (RF) [121](#)
 - software [122](#)
- speeds, download [26](#)
- SPI (Stateful Packet Inspection) [94](#)
- ssh support [111](#)
- SSID (Wi-Fi network name)
 - broadcast [82](#)
 - changing [84](#)
 - description [84](#)
 - Host Name, link to [85](#)
- SSID Broadcast [82](#)
- Standby Timer [56](#)
- Standby Timer on Battery or USB [77](#)
- Start (port, for port forwarding) [99](#)
- start day of the billing cycle, changing [57](#)
- Starts on day [57](#)
- startup failure, device (audio alert) [73](#)
- Stateful Packet Inspection (SPI) [94](#)
- Static IP Assignment List, DHCP [97](#)
- storage guidelines [27](#)
- storage temperature [123](#)
- subnet mask [94](#)
- Support button [59](#)
- support, contacting [109](#)
- Switchback wait time [81](#)
- System alerts [58](#), [73](#), [78](#)
- system events log

- clearing 107
- enabling 107
- exporting 107
- types of events included 106

System ID (SID) 92

system requirements 28

T

TCP/IP settings 96

technical support, contacting 109

telnet support 111

temperature specifications 123

temperature, critical (audio alert) 73

terminal sessions 111

tethered connection

- making 43
- requirements 43
- See also USB

text messaging (SMS) 122

The connection has timed out 119

timeout

- connection timeout (cannot display the home page) 119
- LCD 72

tips 111

TKIP/AES 40, 86

Total (amount of data transferred) 57

Total data 80

trademarks 17

transmission rates 26

transmit frequencies 121

transmitter power 81

Trigger Ports 101

troubleshooting

- cannot connect to the 3G/4G network 120
- cannot connect to Wi-Fi 118
- cannot display the home page 119
- general tips 116

TRU-Install 43

TTY 122

Turn Off Backlight 72

turning the device off 48

turning the device on 33

TVs 112

Tx (transmit) frequencies 121

Tx Power 81

U

Universal Plug and Play (UPnP) 93, 94

Update 3G PRL 81

Update 3G profile 81

Update Failed 118

Update firmware from file 66

updates

- 3G Network Update Available (alert) 49
- automatically check 64
- cannot check for 120
- firmware, upgrade from a file 65
- manually check 65
- overview 64
- PRL 49, 81
- Software Update Available (alert) 50

UPnP (Universal Plug and Play) 94

usage guidelines for your device 27

USB

- charging the device 31, 32
- connecting the device to your computer through USB 43
- location 29
- power settings 56
- requirements 43
- Wi-Fi, disabling when connected through USB 91

user ID, 3G network 92

Username and Password Security 61

V

Verbose System Event Logging 107

vertical row of icons and text 52

vibration specification 123

video conferencing 100

virtual device 47

Voice over Internet Protocol (VoIP) 100

VoIP (Voice over Internet Protocol) 100

VPN

- accessing corporate network through 111
- passthrough types supported 122

W

wait time

- failover 81

- switchback [81](#)
- WAN mode [80](#)
- WAN tab
 - 3G panel [92](#)
 - 4G panel [81](#)
 - Setup panel [80](#)
- warning (EMI) [124](#)
- warning (software settings reset) [103](#)
- warranty [60](#)
- Web browsers supported [28](#)
- Web server, accessing [98](#)
- website
 - CLEAR [109](#)
 - Sierra Wireless [17](#)
- Welcome to Your Device window - Select an Option [108](#)
- WEP [39](#), [86](#)
- whitelist [83](#), [88](#)
- Wi-Fi
 - alerts (user has joined, or left) [73](#), [78](#)
 - cannot connect [118](#)
 - channel [91](#)
 - configuring, overview [84](#)
 - connected computers, displaying list of [90](#)
 - connecting to [110](#)
 - longer Wi-Fi range [56](#), [71](#), [82](#)
 - MAC Filter panel of the Wi-Fi tab [83](#)
 - maximum number of users [90](#)
 - network name (SSID) [84](#)
 - Network panel of the Wi-Fi tab [82](#)
 - password [87](#)
 - Password Reminder [88](#)
 - password, forgot [110](#)

- performance, tips on improving [113](#)
- security [86](#)
- security and encryption protocols supported [122](#)
- Security panel of the Wi-Fi tab [83](#)
- sounds when user joins or leaves [58](#)
- SSID (Wi-Fi network name) [84](#)
- USB tethered mode [91](#)
- Wi-Fi users information [55](#)
- Wi-Fi Channel [91](#)
- Wi-Fi Firmware Version [67](#), [79](#)
- Wi-Fi Passwordl [87](#)
- Wi-Fi Security Options window [39](#)
- Wi-Fi user has joined [58](#), [73](#), [78](#)
- Wi-Fi user has left [58](#), [73](#), [78](#)
- Windows device driver, installing [44](#)
- Windows XP
 - Wi-Fi performance, tips on improving [113](#)
- wireless speakers [112](#)
- WPA [40](#), [86](#)
- WPA2 [40](#), [86](#)
- WWAN IP address of the device [57](#)

X

- XP, Windows
 - Wi-Fi performance, tips on improving [113](#)

Y

- Your device is now restarting (window) [40](#)



SIERRA
WIRELESS