



**User Instruction Manual for:**  
 RollGliss® Rescue Emergency Descent Device  
 with Auto-Retract  
 (Model Numbers: See Figure 1)

**USER INSTRUCTION MANUAL**  
**ROLLGLISS® RESCUE EMERGENCY DESCENT DEVICE**  
**WITH AUTO-RETRACT**

This manual is intended to be used as part of an employee training program as required by OSHA.

**WARNING:** This product is part of an emergency descent system. The user must follow manufacturer's instructions for each part of the system. These instructions must be provided to the user of this equipment. The user must read and understand these instructions before using this equipment. Manufacturer's instructions must be followed for proper use and maintenance of this equipment. Alterations or misuse of this equipment, or failure to follow instructions, may result in serious injury or death.

**IMPORTANT:** If you have questions on the use, care, or suitability of this equipment for your application contact Capital Safety.

**IMPORTANT:** Record the product identification information from the ID label in the Inspection and Maintenance Log in Section 9.0 of this manual.

**DESCRIPTION**

The Emergency Descent Device is available as a vertical or sloped descent model. The vertical descent model incorporates a snap hook attached to the device lifeline. The sloped descent model is designed to be attached to a guide cable, and includes a Guide Cable Sleeve and Suspension Bar Kit. See Figure 1.

<b>Figure 1 - RollGliss Rescue Emergency Descent Device</b>		
A	Emergency Descent Device for Vertical Descent	3303000, 3303002, 3303007, 3303030, 3303051
B	Emergency Descent Device with Guide Cable Sleeve and Suspension Bar Kit for Sloped Descent	3303001, 3303003, 3303004, 3303005, 3303006



## 1.0 APPLICATION

- 1.1 PURPOSE:** The Emergency Descent Device is available as a vertical or sloped descent model (see Figure 1). The vertical descent model incorporates a snap hook attached to the device lifeline. The sloped descent model is designed to be attached to a guide cable, and includes a Guide Cable Sleeve and Suspension Bar Kit.

**WARNING:** *The Emergency Descent Device must not be used as a fall arrest device.*

- 1.2 LIMITATIONS:** The following application limitations must be recognized and considered before using this product:
- A. CAPACITY:** This equipment is designed for use by persons with a combined weight (including tools, clothing, body support, etc.) of 75 lbs. (34 kg) to 310 lbs. (141 kg).
  - B. DESCENT SPEED:** The speed at which the user will be lowered when using the Emergency Descent Device increases with the combined weight of the user. For vertical descents the approximate descent speeds are as follows:

120 lbs. (54 kg) Combined Weight: 6.8 ft/s (2.1 m/s)  
220 lbs. (100 kg) Combined Weight: 8.8 ft/s (2.7 m/s)  
300 lbs. (136 kg) Combined Weight: 10.0 ft/s (3.0 m/s)

The model 3303051 Vertical Descent Device is equipped with a larger brake than the other auto-retract models so descent speed will be slower. Approximate descent speed is as follows:

310 lbs. (141 kg) Combined Weight: 6.0 ft/s (1.8 m/s)

When using the Emergency Descent Device with a guide cable, the descent speed of the user will decrease as the slope of the guide cable decreases. Table 1 lists typical descent speeds of a High-Speed Descender (e.g., model 3303005) for various slopes and weights.

- C. HAZARDOUS AREAS:** Use of this equipment in hazardous areas may require additional precautions to reduce the possibility of injury to the user or damage to the equipment. Hazards may include, but are not limited to: high heat, caustic chemicals, corrosive environments, high voltage power lines, explosive or toxic gases, moving machinery, and sharp edges.
  - D. TRAINING:** This equipment is intended to be installed and used by persons trained in its correct application and use.
- 1.3 APPLICABLE STANDARDS:** Refer to local, state, and federal (OSHA) standards for requirements governing the use of this equipment.

**Table 1 - Descent Speed: Sloped High-Speed Descender**

<b>Angle (from horizontal)</b>	<b>Weight: lbs (kg)</b>	<b>Descent Speed (ft/s)</b>	<b>Descent Speed (m/s)</b>
45°	120 (54)	12.50	3.81
45°	220 (100)	17.24	5.25
45°	300 (136)	20.65	6.29
40°	120 (54)	11.92	3.63
40°	220 (100)	16.24	4.95
40°	300 (136)	19.37	5.90
35°	120 (54)	11.29	3.44
35°	220 (100)	15.16	4.62
35°	300 (136)	17.97	5.48
30°	120 (54)	10.62	3.24
30°	220 (100)	14.00	4.27
30°	300 (136)	16.47	5.02
25°	120 (54)	9.91	3.02
25°	220 (100)	12.76	3.89
25°	300 (136)	14.87	4.53
20°	120 (54)	9.15	2.79
20°	220 (100)	11.46	3.49
20°	300 (136)	13.18	4.02
15°	120 (54)	8.38	2.55
15°	220 (100)	10.11	3.08
15°	300 (136)	11.40	3.47

## **2.0 SYSTEM REQUIREMENTS**

- 2.1 COMPATIBILITY OF COMPONENTS:** DBI-SALA equipment is designed for use with DBI-SALA approved components and subsystems only. Substitutions or replacements made with non-approved components or subsystems may jeopardize compatibility of equipment and may effect the safety and reliability of the complete system.
- 2.2 COMPATIBILITY OF CONNECTORS:** Connectors (hooks, carabiners, D-rings) used to suspend the Emergency Descent Device must be capable of supporting at least 3,100 lbs (1,406 kg). Connectors must be compatible in size, shape, and strength. Non compatible connectors may unintentionally disengage (roll-out). Roll-out occurs when interference between the connector and anchorage connector causes the hook or carabiner gate to unintentionally open and release. Self locking snap hooks and carabiners must be used with this system to reduce the possibility of roll-out. Do not use connectors that will not completely close over the attachment element.
- 2.3 ANCHORAGE STRENGTH - EMERGENCY DESCENT DEVICE:** Anchorages used to suspend the Emergency Descent Device must sustain static loads, applied along the axis of the device, of at least 3,100 lbs (1,406 kg). When more than one Emergency Descent Device is attached to an anchorage the strengths stated above must be multiplied by the number of descent devices attached to the anchorage. Anchorages used to support a guide cable, when applicable, must be sufficiently strong to withstand the forces generated in the guide cable during descent.
- 2.4 GUIDE CABLE:** Applications with a sloped descent require a guide cable (see Figure 2). Systems requiring a guide cable must be designed by a qualified person. The angle at which the guide cable is secured, as well as the amount of sag in the guide cable, will affect the descent speed. The guide cable must be installed with sufficient slope and limited sag to ensure the user will reach the landing area in the event of an emergency descent. The guide cable and the anchorage point must support the weight of the user in a descent. Guide cable must be 3/8 inch (.9525 cm) to 5/8 inch (1.5875 cm) wire rope. The operation of the emergency descent system should be verified by performing a test descent in accordance with section 3.2.C.

**ANCHORAGE STRENGTH - GUIDE CABLE:** The table in Figure 2 provides approximate recommended anchorage strengths for various system configurations using 115 ft. (35 m) long, 5/8 inch (1.5875 m), 7x19 steel aircraft cable. When the angle of the guide cable from horizontal is 90 degrees or more, a minimum anchorage strength of 5,000 lbs (2,268 kg) is recommended.

**Figure 2 - Installation Options & Guide Cable Anchorage Strengths**

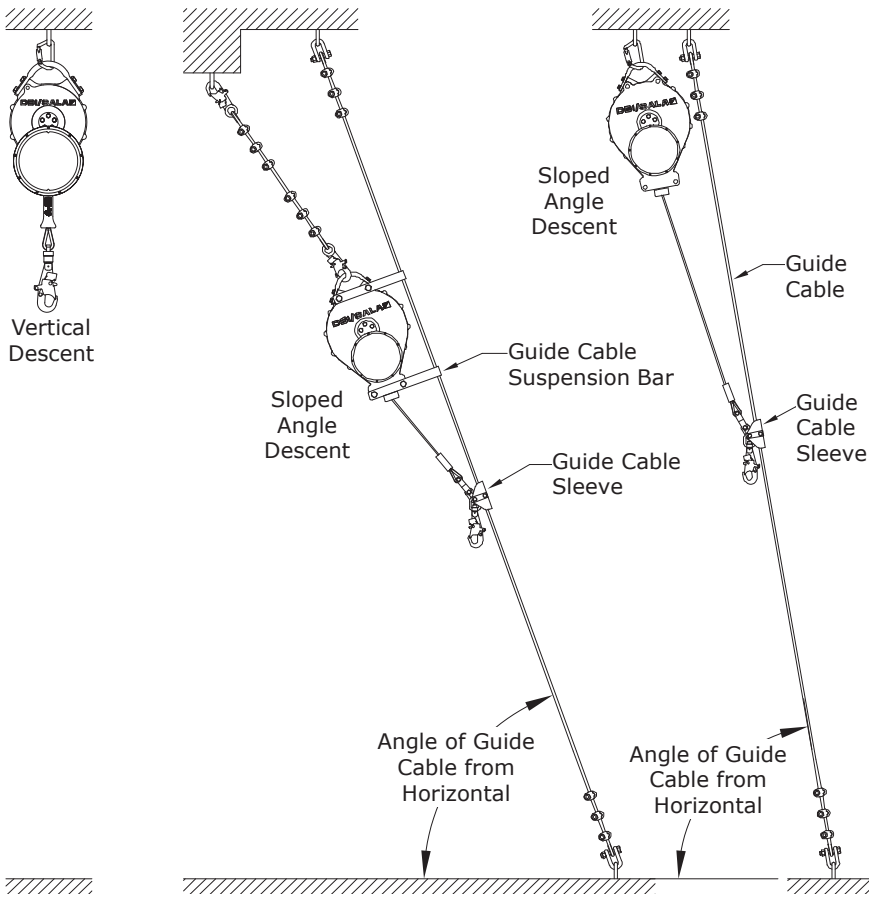

Angle of Guide Cable from Horizontal	Guide Cable Pretension	Initial Guide Cable Sag	Recommended Anchorage Strength (including 2:1 Safety Factor)
75 Degrees	610 lbs (2.71 kN)	6 in (15.24 cm)	6,700 lbs (29.80 kN)
75 Degrees	310 lbs (1.38 kN)	12 in (30.48 cm)	5,600 lbs (24.91 kN)
75 Degrees	150 lbs (0.67 kN)	24 in (60.96 cm)	5,000 lbs (22.24 kN)
75 Degrees	80 lbs (0.36 kN)	48 in (121.92 cm)	5,000 lbs (22.24 kN)
60 Degrees	1,180 lbs (5.25 kN)	6 in (15.24 cm)	10,900 lbs (48.49 kN)
60 Degrees	590 lbs (2.62 kN)	12 in (30.48 cm)	9,900 lbs (44.04 kN)
60 Degrees	300 lbs (1.33 kN)	24 in (60.96 cm)	8,100 lbs (36.03 kN)
60 Degrees	150 lbs (0.67 kN)	48 in (121.92 cm)	5,200 lbs (23.13 kN)
45 Degrees	1,670 lbs (7.42 kN)	6 in (15.24 cm)	14,000 lbs (62.28 kN)
45 Degrees	840 lbs (3.74 kN)	12 in (30.48 cm)	13,000 lbs (57.83 kN)
45 Degrees	420 lbs (1.87 kN)	24 in (60.96 cm)	11,300 lbs (50.25 kN)
45 Degrees	210 lbs (0.94 kN)	48 in (121.92 cm)	8,100 lbs (38.03 kN)

## 3.0 INSTALLATION AND USE

- 3.1 BEFORE EACH USE:** Before each use of this equipment carefully inspect it according to section 5.0 of this manual.
- 3.2 PLANNING:** Plan your emergency escape system and how it will be used before starting your work. Consider all factors that will affect your safety before, during, and after an escape. Consider the following when planning your system:
- A. ANCHORAGE:** Select a rigid anchorage point that is capable of supporting at least 3,100 lbs (1,406 kg). See Section 2.3.
  - B. DESCENT PATH AND LANDING AREA CLEARANCE:** Your descent path must be unobstructed. The landing area must be clear of obstructions to permit safe landing of the user. Failure to provide an unobstructed descent path and landing area may result in serious injury.
  - C. TESTING THE SYSTEM:** DBI-SALA recommends performing a test descent using a 120 lb (55 kg) weight (minimum). The descent speed should be uniform, and allow the user to reach the landing area safely. For vertical descent applications, the descent speed should be approximately as stated in section 1.2.B. Descent speed will be lower for sloped applications.
  - D. SHARP EDGES:** Avoid using this equipment where system components will be in contact with, or abrade against, unprotected sharp edges. If working with this equipment near sharp edges is unavoidable, cover the sharp edge with a heavy pad.
  - E. AFTER A DESCENT:** After use of the emergency escape system, the auto retract function will retract the device line back to the device under control. The escape system is now ready for another descent
- 3.3 INSTALLATION:** The emergency escape device may be configured in a vertical or sloped application. See Figure 2 for acceptable installation configurations.

**WARNING:** *Emergency Descent Device models for vertical descent (see Figure 1) should not be used in sloped applications.*

- 3.4 CONNECTING THE EMERGENCY DESCENT DEVICE TO ANCHORAGE:** Figure 3 illustrates attachment of the Emergency Descent Device to the anchorage. See section 2.0 for compatibility and anchorage strength requirements.

**Figure 3 - Connection the Emergency Descent Device to Anchorage**

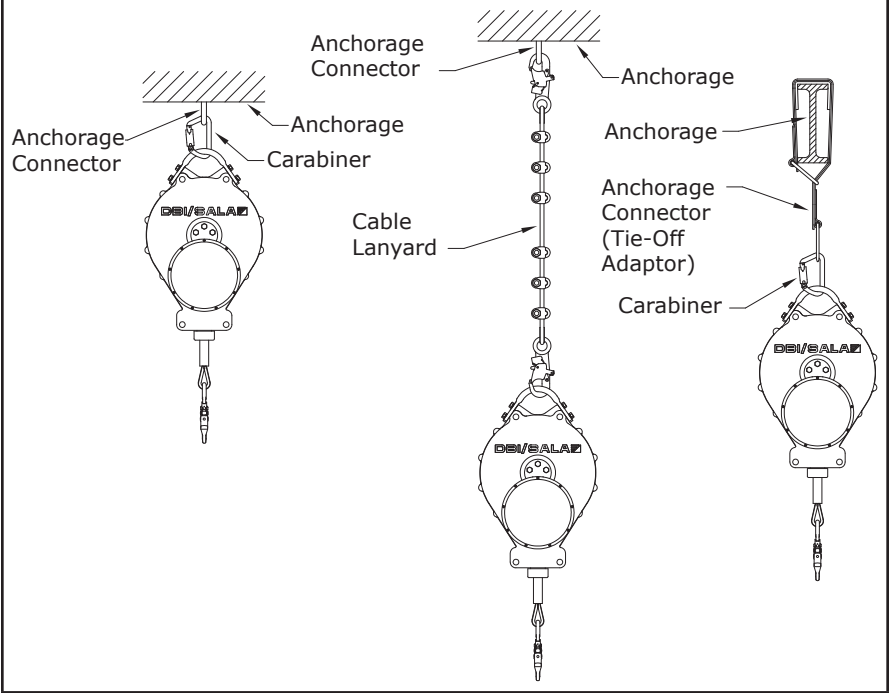

**3.5 CONNECTING THE EMERGENCY DESCENT DEVICE TO A GUIDE CABLE:** Some sloped angle descent applications may require attaching the Emergency Descent Device to the guide cable (see Figure 2). Use the Guide Cable Sleeve and Suspension Bar Kit (Part No. 3302981) to attach the Emergency Descent Device to the guide cable as shown in Figure 4.

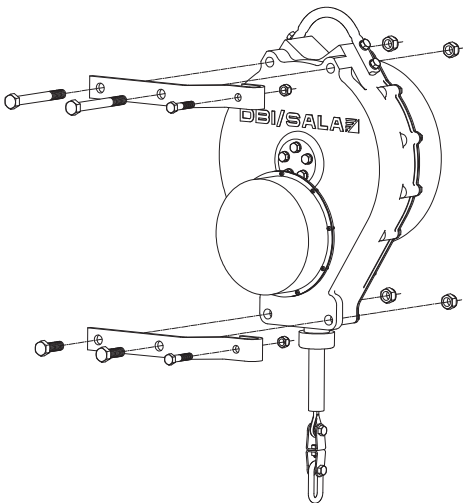

**Figure 4 - Connecting Emergency Descent Device to a Guide Cable - Sloped Descent Application**

Suspension Bar (2) See Installation Detail

Guide Cable  
3/8" - 5/8"  
(.9525 cm - 1.5875 cm)  
Wire Rope

Guide Cable Sleeve  
See Installation Detail



Suspension Bar Installation Detail

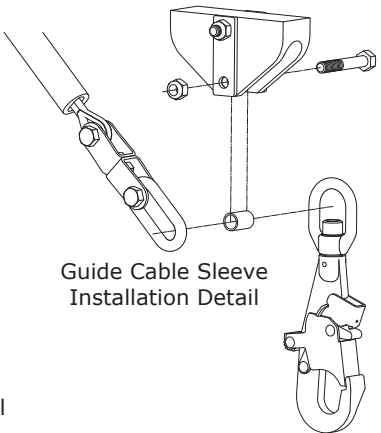

Guide Cable Sleeve  
Installation Detail

**3.6 CONNECTING TO YOUR BODY SUPPORT:** A full body harness or other means of supporting the user must be used with this device. Do not use a body belt with this device. When using a full body harness, connect to the front or back D-ring (Figure 5). Ensure the D-ring is positioned to hold yourself upright. See full body harness manufacturer's instructions for more information.

**WARNING:** Do not use a body belt with this equipment. Body belts do not support your entire body, which may result in serious injury.

**3.7 USE:** Connect to the appropriate connection on your body support. Check your descent path and landing area for obstructions before stepping off the structure. The device will allow you to descend at a rapid rate. Do not grasp the guide cable while descending. Bend your knees and be prepared for landing. After landing, disconnect from your body support. The connecting hook will retract back to the device.

**WARNING:** The users of this equipment must be in good physical condition. The device will allow rapid descent; the user must have the ability to absorb the landing.

**Figure 5 - Connecting to a Full Body Harness**

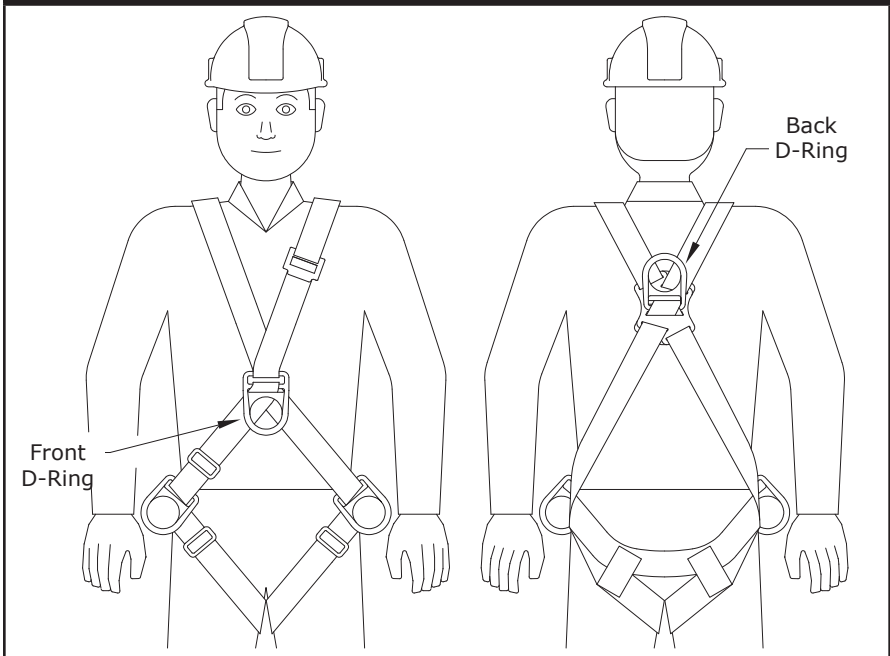

## 4.0 TRAINING

- 4.1** It is the responsibility of the user and purchaser of this equipment to be trained in the correct care and use of this equipment. The user and purchaser must be aware of the operating characteristics, application limits, and consequences of improper use of this equipment.

**WARNING:** Training must be conducted without exposing the trainee to a fall hazard. Training should be repeated on a periodic basis

## 5.0 INSPECTION

- 5.1 MONTHLY:** 5.1 A formal inspection should be completed by a competent person other than the user. A formal inspection should be completed if the system parameters are changed, such as after a system is moved, Re-rigged, anchorages moved, guide cable angle changed, etc. Extreme working conditions may require increasing the Inspection frequency. Inspect the Emergency Descent Device according to sections 5.2 and 5.3. Record inspection results in the Inspection and Maintenance Log, or use the i-Safe™ inspection web portal to maintain your inspection records.

**EVERY TWO YEARS:** The device must be sent to an authorized service center for inspection and service. See section 6.2.

**i-Safe™ RFID Tag:** Some Emergency Descent Device models are equipped with an i-Safe™ Radio Frequency Identification (RFID) tag. The i-Safe™ RFID tag on the Emergency Descent Device can be used in conjunction with the i-Safe handheld reading device and the web based portal to simplify inspection and inventory control and provide records for your fall protection equipment. If you are a first-time user, contact a Customer Service representative in the US at 800-328-6146 or in Canada at 800-387-7484 or if you have already registered, go to: [www.capitalsafety.com/isafe.html](http://www.capitalsafety.com/isafe.html). Follow the instructions provided with your i-Safe handheld reader or on the web portal to transfer your data to your web log.

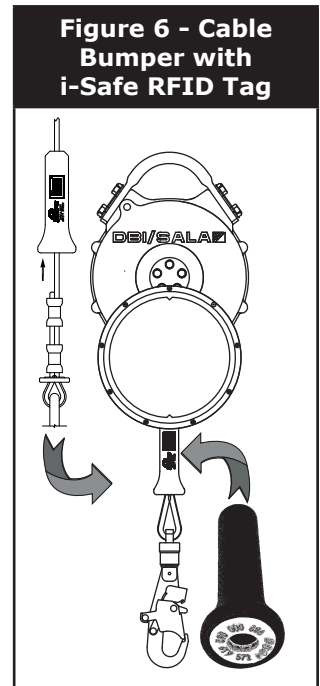

## **5.2 INSPECTION STEPS:**

- Step 1.** Inspect device for loose fasteners and bent or damaged parts.
- Step 2.** Inspect device housing for distortion, cracks, or other damage. Ensure the anchorage handle is not damaged or distorted.
- Step 3.** Device lifeline must pull out and retract fully. Inspect entire wire rope for cuts, kinks, broken wires, corrosion, or severely abraded areas. Slide the cable bumper up and inspect the wire rope and ferrules for cracks, corrosion, broken wires, etc. (see Figure 6).
- Step 4.** Device labels must be present and fully legible. See section 8.0.
- Step 5.** Inspect for corrosion on the entire device.
- Step 6.** Inspect connecting hooks or carabiners for damage, corrosion, and working condition.
- Step 7.** Inspect Guide Cable Sleeve for excessive wear.
- Step 8.** Inspect guide cable. Inspect wire rope for cuts, kinks, broken wires, corrosion, or severely abraded areas. If guide cable is damaged do not use the system.
- Step 9.** Inspect each system component and subsystem according to manufacturer's instructions.
- Step 10.** Record inspection results in the Inspection and Maintenance Log (Section 9.0) or on the i-Safe web portal.

**5.3 UNSAFE OR DEFECTIVE CONDITIONS:** If inspection reveals an unsafe or defective condition, remove the device from service and contact an authorized service center for repair.

## **6.0 MAINTENANCE, SERVICE, STORAGE**

- 6.1 MAINTENANCE:** Periodically clean the exterior of the Emergency Descent Device with water and mild detergent. Position the device so excess water can drain out. Clean labels as required. Clean device lifeline with water and mild detergent. Rinse and thoroughly air dry. Do not force dry with heat. An excessive buildup of dirt, paint, etc., may prevent the lifeline from retracting back to the device.
- 6.2 SERVICING:** Maintenance and servicing must be completed by an authorized service center. An authorization and return number must be issued by DBI-SALA. Do not attempt to disassemble the device. The Emergency Descent Device is required to be serviced at least every two years by an authorized service center. Extreme working conditions may require increasing the service frequency. Contact DBI-SALA for service frequencies when this equipment is used in extreme working conditions. Service shall include

an intensive inspection and cleaning of all components. Failure to provide required service may shorten the product life and compromise safety and performance.

**NOTE:** Only DBI-SALA or parties authorized in writing may make repairs to this equipment.

**6.3 STORAGE:** Store the Emergency Descent Device in a cool, dry, clean environment, out of direct sunlight. Avoid areas where chemical or organic vapors are present. Thoroughly inspect the Emergency Descent Device after extended storage.

## **7.0 SPECIFICATIONS**

### **7.1 MATERIALS:**

#### **Emergency Descent Device:**

Housing:	Cast Aluminum
Housing Cover:	Stainless Steel
Anchorage Handle:	Stainless Steel
Fasteners:	Stainless Steel
Main Shaft:	Stainless Steel
Motor Spring:	Carbon Spring Steel
Connecting Hook:	Forged Alloy Steel
Cable Bumper:	Urethane
Lifeline (Galvanized):	3/16" (.47625 cm) dia, 7x19 Aircraft Wire Rope, 4,200 lbs (16 kN) minimum tensile strength
Lifeline (Stainless Steel):	3/16" (.47625 cm) dia. 7x19 Aircraft Wire Rope, 3,600 lbs (16 kN) minimum tensile strength
Finish Paint:	Polyester Baked Finish
Lifeline Guide:	Nylon with Stainless Steel

#### **Guide Cable Sleeve and Suspension Bar Kit:**

Guide Cable Sleeve:	Nylon Wear Pad, Stainless Steel Side Plates and Fasteners
Suspension Bars and Mounting Hardware:	Stainless Steel

### **7.2 PERFORMANCE SPECIFICATIONS:**

Capacity:	75-310 lbs (34-141 kg), One Person
Safety Factor at Rated Load:	10:1
Nominal Descent Speed: (Low-Speed Vertical Descent)	115' - 135' (35 - 41 m) = 8 ft/s (2.4 m/s) 50' (15 m) = 6 ft/s (1.8 m/s)
Approximate Descent Device Weight: (based on Lifeline Length)	115' - 135' (35 - 41 m) = 63 lbs (29 kg) 50' (15 m) = 31 lbs (14 kg)
Guide Cable and Suspension Bar Kit Weight:	5.2 lbs (2.4 kg)
Device meets OSHA requirements:	Yes

## 8.0 LABELING

The following labels should be securely attached to the RollGliss Rescue Emergency Descent Device:

**DBI SALA**®  
 USA: (800) 328-6146  
 CANADA: (800) 887-7484  
 www.capitalsafety.com

**SPECIFICATIONS**  
 Capacity: 75-310 lbs. (34-141 kg)  
 Made in the USA  
**NOMINAL DESCENT SPEED**  
 (ft/sec):

**MATERIAL:** LENGTH (ft.):

Lifeline material designation: 3/16 in. (5mm) dia. 7x19 galvanized steel (G) or stainless steel (S). Meets OSHA requirements.

**WARNING**  
 Instructions provided with this product at time of shipment must be followed for proper use. Failure to follow instructions may result in serious injury or death.

**INSPECTION** Before each use inspect each device in accordance with user manual including locking function (pull sharply to test), retraction function, lifeline condition, function and condition of connectors, housing and fasteners, legibility of labels, and any evidence of defects, damage, or missing parts. Inspection by competent person required at least annually, see user manual. Annual factory authorized service required in Canada. Do not use if inspection reveals an unsafe condition. Not user repairable.

**USE** This device is designed for emergency use only. The minimum required anchorage strength is 3100 lbs. (13.77 MN). Personnel are recommended to wear full body harnesses when using this unit. Avoid lifeline contact with sharp edges. For use by trained persons only.

330293 REV 6

**Instruction Label**

SERIAL NO.	XXXXXXXX
MODEL NO.	
DATE OF MFR.	
LOT NO.	
DATE OF LAST SERVICE	

**Identification Label**

**DBI SALA**®  
 USA: (800) 328-6146  
 CANADA: (800) 387-7484  
 www.capitalsafety.com

0086  
 EN341-1993  
 CLASS C

**SPECIFICATIONS**  
 Capacity: 75-310 lbs. (34-141 kg)  
 Max. Descent Height: 50 ft (15.2 m)  
 Made in the USA  
 Single User, Multiple Use.  
 NOMINAL DESCENT SPEED: 6 ft/sec (1.83 m/s)

**MATERIAL:** LENGTH(ft):

Lifeline material designation: 3/16 in. (5mm) dia. 7x19 galvanized steel (G) or stainless steel (S). Meets OSHA requirements.

**WARNING**  
 Instructions provided with this product at time of shipment must be followed for proper use. Failure to follow instructions may result in serious injury or death.

**INSPECTION** Before each use inspect each device in accordance with user manual including retraction function, lifeline condition, function and condition of connectors, housing and fasteners, legibility of labels, and any evidence of defects, damage, or missing parts. Inspection by competent person required at least annually, see user manual. Annual factory authorized service required in Canada. Do not use if inspection reveals an unsafe condition. Not user repairable.

**INSTRUCTIONS** Connect to your front or back D-ring. Check your descent path and landing area for obstructions before stepping off the structure. The device will allow you to descend at a rapid rate. Bend your knees and be prepared for landing. After landing, disconnect from your body support. The connecting hook will retract back to the device.

**USE** This device is designed for emergency use only. The minimum required anchorage strength is 3100 lbs. (13.77MN). Personnel are recommended to wear full body harnesses when using this unit. Avoid lifeline contact with sharp edges. For use by trained persons only.

3303051 REV 3

**Instruction Label (Model 3303051)**

**SALA** *i-safe*

This product is i-Safe enabled and contains an electronic tag that can be read by compatible readers – providing inspection logs, inventory management and other safety information.  
 Ce produit est validé dans i-Safe et contient une rondelle d'identification électronique qui peut être lue par des lecteurs compatibles – en fournissant des registres d'inspection, de l'informations sur la gestion des stocks et d'autre information relative à la protection.

9502313 REV B

**i-Safe™ RFID Label**

# 9.0 INSPECTION AND MAINTENANCE LOG

SERIAL NUMBER: \_\_\_\_\_

MODEL NUMBER: \_\_\_\_\_

DATE PURCHASED: \_\_\_\_\_ DATE FIRST USED: \_\_\_\_\_

INSPECTION DATE	INSPECTION ITEMS NOTED	CORRECTIVE ACTION	MAINTENANCE PERFORMED
Approved By: _____			
Approved By: _____			
Approved By: _____			
Approved By: _____			
Approved By: _____			
Approved By: _____			
Approved By: _____			
Approved By: _____			
Approved By: _____			
Approved By: _____			
Approved By: _____			
Approved By: _____			
Approved By: _____			

## WARRANTY

Equipment offered by DBI-SALA is warranted against factory defects in workmanship and materials for a period of two years from date of installation or use by the owner, provided that this period shall not exceed two years from date of shipment. Upon notice in writing, DBI-SALA will promptly repair or replace all defective items. DBI-SALA reserves the right to elect to have any defective item returned to its plant for inspection before making a repair or replacement. This warranty does not cover equipment damages resulting from abuse, damage in transit, or other damage beyond the control of DBI-SALA. This warranty applies only to the original purchaser and is the only one applicable to our products, and is in lieu of all other warranties, expressed or implied.



### CSG USA

3833 Sala Way  
Red Wing, MN 55066-5005  
Toll Free: 800.328.6146  
Phone: 651.388.8282  
Fax: 651.388.5065  
solutions@capitalsafety.com

### CSG Canada Ltd.

260 Export Boulevard  
Mississauga, Ontario L5S 1Y9  
Toll Free: 800.387.7484  
Phone: 905.795.9333  
Fax: 905.795.8777  
sales.ca@capitalsafety.com

[www.capitalsafety.com](http://www.capitalsafety.com)



Certificate No. FM 39709