

**DAIKIN**

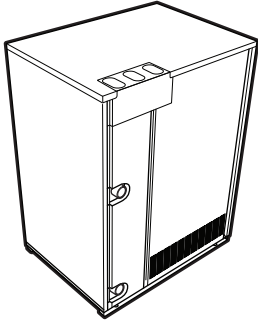

# Installer and user reference guide

## VRV IV water-cooled system air conditioner



**RWEYQ8T9Y1B  
RWEYQ10T9Y1B  
RWEYQ12T9Y1B  
RWEYQ14T9Y1B**

Installer and user reference guide  
VRV IV water-cooled system air conditioner

**English**

## Table of contents

<b>1</b>	<b>General safety precautions</b>	<b>3</b>
1.1	About the documentation	3
1.1.1	Meaning of warnings and symbols	3
1.2	For the user	4
1.3	For the installer	4
1.3.1	General	4
1.3.2	Installation site	5
1.3.3	Refrigerant	5
1.3.4	Brine	5
1.3.5	Water	6
1.3.6	Electrical	6

<b>2</b>	<b>About the documentation</b>	<b>7</b>
2.1	About this document	7

### For the installer 7

<b>3</b>	<b>About the box</b>	<b>7</b>
3.1	Overview: About the box	7
3.2	To unpack the outdoor unit	7
3.3	To remove the accessories from the outdoor unit	8
3.4	Accessory pipes: Diameters	8
3.5	To remove the transportation stay	8

<b>4</b>	<b>About the units and options</b>	<b>9</b>
4.1	Overview: About the units and options	9
4.2	Identification label: Outdoor unit	9
4.3	About the outdoor unit	9
4.4	System layout	9
4.5	Combining units and options	10
4.5.1	About combining units and options	10
4.5.2	Possible combinations of indoor units	10
4.5.3	Possible combinations of outdoor units	10
4.5.4	Possible options for the outdoor unit	11

<b>5</b>	<b>Preparation</b>	<b>11</b>
5.1	Overview: Preparation	11
5.2	Preparing the installation site	11
5.2.1	Installation site requirements of the outdoor unit	11
5.2.2	Securing safety against refrigerant leaks	12
5.3	Preparing refrigerant piping	13
5.3.1	Refrigerant piping requirements	13
5.3.2	To select the piping size	13
5.3.3	To select refrigerant branch kits	15
5.3.4	About the piping length	15
5.3.5	Single outdoor units and standard multi-outdoor-unit combinations	16
5.3.6	Multiple outdoor units: Possible layouts	18
5.4	Preparing water piping	19
5.4.1	Water quality requirements	19
5.4.2	Water circuit requirements	19
5.4.3	Handling the brazed plate heat exchanger	20
5.4.4	About the water flow rate	20
5.5	Preparing electrical wiring	21
5.5.1	About electrical compliance	21
5.5.2	Safety device requirements	22







<b>6</b>	<b>Installation</b>	<b>22</b>
6.1	Overview: Installation	22
6.2	Opening the units	22
6.2.1	To open the outdoor unit	22
6.2.2	To open the electrical component box of the outdoor unit	23
6.3	Mounting the outdoor unit	23
6.3.1	To provide the installation structure	23

6.4	Connecting the refrigerant piping	23
6.4.1	Precautions when connecting the refrigerant piping	23
6.4.2	About connecting the refrigerant piping	23
6.4.3	To route the refrigerant piping	23
6.4.4	To connect the refrigerant piping to the outdoor unit	24
6.4.5	To connect the multi connection piping kit	24
6.4.6	To connect the refrigerant branching kit	24
6.4.7	To protect against contamination	24
6.4.8	To braze the pipe end	25
6.4.9	Using the stop valve and service port	25
6.4.10	To remove the pinched pipes	26
6.5	Checking the refrigerant piping	27
6.5.1	About checking the refrigerant piping	27
6.5.2	Checking refrigerant piping: General guidelines	27
6.5.3	Checking refrigerant piping: Setup	27
6.5.4	To perform a leak test	28
6.5.5	To perform vacuum drying	28
6.6	Charging refrigerant	28
6.6.1	Precautions when charging refrigerant	28
6.6.2	About charging refrigerant	29
6.6.3	To determine the additional refrigerant amount	29
6.6.4	To charge refrigerant	29
6.6.5	Checks after charging refrigerant	30
6.6.6	To fix the fluorinated greenhouse gases label	30
6.7	Connecting the water piping	31
6.7.1	About connecting the water piping	31
6.7.2	Precautions when connecting the water piping	31
6.7.3	To connect the water piping	31
6.7.4	To fill the water circuit	31
6.7.5	To insulate the water piping	31
6.8	Connecting the electrical wiring	31
6.8.1	Precautions when connecting electrical wiring	31
6.8.2	Field wiring: Overview	32
6.8.3	About the electrical wiring	32
6.8.4	To route and fix the transmission wiring	33
6.8.5	To connect the transmission wiring	33
6.8.6	To finish the transmission wiring	34
6.8.7	To route and fix the power supply	34
6.8.8	To connect the power supply	34
6.8.9	To connect the optional wiring	34

<b>7</b>	<b>Configuration</b>	<b>35</b>
7.1	Overview: Configuration	35
7.2	Making field settings	36
7.2.1	About making field settings	36
7.2.2	Field setting components	36
7.2.3	To access the field setting components	36
7.2.4	To access mode 1 or 2	36
7.2.5	To use mode 1	37
7.2.6	To use mode 2	37
7.2.7	Mode 1: Monitoring settings	38
7.2.8	Mode 2: Field settings	38
7.2.9	To connect the PC configurator to the outdoor unit	40

<b>8</b>	<b>Commissioning</b>	<b>40</b>
8.1	Overview: Commissioning	40
8.2	Precautions when commissioning	40
8.3	Checklist before commissioning	40
8.4	About the test run	41
8.5	To perform a test run	41
8.6	Correcting after abnormal completion of the test run	42
8.7	Operating the unit	42

<b>9</b>	<b>Maintenance and service</b>	<b>42</b>
9.1	Overview: Maintenance and service	42
9.2	Maintenance safety precautions	42
9.2.1	To prevent electrical hazards	42
9.3	Maintenance of the plate heat exchanger	42
9.3.1	To clean the plate heat exchanger	42
9.4	About service mode operation	43

9.4.1	To use vacuum mode .....	43	19.2.5	Symptom: The fan direction does not correspond to the setting .....	53
9.4.2	To recover refrigerant .....	43	19.2.6	Symptom: White mist comes out of a unit (Indoor unit) .....	53
<b>10</b>	<b>Troubleshooting</b> .....	<b>43</b>	19.2.7	Symptom: White mist comes out of a unit (Indoor unit, outdoor unit) .....	53
10.1	Overview: Troubleshooting .....	43	19.2.8	Symptom: The user interface display reads "U4" or "U5" and stops, but then restarts after a few minutes ..	53
10.2	Solving problems based on error codes .....	43	19.2.9	Symptom: Noise of air conditioners (Indoor unit) .....	53
<b>11</b>	<b>Disposal</b> .....	<b>43</b>	19.2.10	Symptom: Noise of air conditioners (Indoor unit, outdoor unit) .....	53
<b>12</b>	<b>Technical data</b> .....	<b>44</b>	19.2.11	Symptom: Noise of air conditioners (Outdoor unit) .....	53
12.1	Overview: Technical data .....	44	19.2.12	Symptom: Dust comes out of the unit .....	53
12.2	Service space: Outdoor unit .....	44	19.2.13	Symptom: The units can give off odours .....	53
12.3	Piping diagram: Outdoor unit .....	44	19.2.14	Symptom: The outdoor unit fan does not spin .....	53
12.4	Wiring diagram: Outdoor unit .....	45	19.2.15	Symptom: The display shows "88" .....	53
<b>For the user</b> .....		<b>46</b>	19.2.16	Symptom: The compressor in the outdoor unit does not stop after a short heating operation .....	54
<b>13</b>	<b>About the system</b> .....	<b>46</b>	19.2.17	Symptom: The inside of an outdoor unit is warm even when the unit has stopped .....	54
13.1	System layout .....	46	19.2.18	Symptom: Hot air can be felt when the indoor unit is stopped .....	54
<b>14</b>	<b>User interface</b> .....	<b>47</b>	<b>20</b>	<b>Relocation</b> .....	<b>54</b>
<b>15</b>	<b>Before operation</b> .....	<b>47</b>	<b>21</b>	<b>Disposal</b> .....	<b>54</b>
<b>16</b>	<b>Operation</b> .....	<b>47</b>	<b>22</b>	<b>Glossary</b> .....	<b>54</b>
16.1	Operation range .....	47	<b>1 General safety precautions</b>		
16.2	Operating the system .....	47	<b>1.1 About the documentation</b>		
16.2.1	About operating the system .....	47	<ul style="list-style-type: none"> <li>• The original documentation is written in English. All other languages are translations.</li> <li>• The precautions described in this document cover very important topics, follow them carefully.</li> <li>• The installation of the system, and all activities described in the installation manual and the installer reference guide <b>MUST</b> be performed by an authorised installer.</li> </ul>		
16.2.2	About cooling, heating, fan only, and automatic operation .....	47	<b>1.1.1 Meaning of warnings and symbols</b>		
16.2.3	About the heating operation .....	47	<div style="border: 1px solid black; padding: 5px; margin-bottom: 5px;">  <b>DANGER</b> Indicates a situation that results in death or serious injury.         </div> <div style="border: 1px solid black; padding: 5px; margin-bottom: 5px;">  <b>DANGER: RISK OF ELECTROCUTION</b> Indicates a situation that could result in electrocution.         </div> <div style="border: 1px solid black; padding: 5px; margin-bottom: 5px;">  <b>DANGER: RISK OF BURNING</b> Indicates a situation that could result in burning because of extreme hot or cold temperatures.         </div> <div style="border: 1px solid black; padding: 5px; margin-bottom: 5px;">  <b>DANGER: RISK OF EXPLOSION</b> Indicates a situation that could result in explosion.         </div> <div style="border: 1px solid black; padding: 5px; margin-bottom: 5px;">  <b>WARNING</b> Indicates a situation that could result in death or serious injury.         </div> <div style="border: 1px solid black; padding: 5px; margin-bottom: 5px;">  <b>WARNING: FLAMMABLE MATERIAL</b> </div> <div style="border: 1px solid black; padding: 5px;">  <b>CAUTION</b> Indicates a situation that could result in minor or moderate injury.         </div>		
16.2.4	To operate the system (WITHOUT cool/heat changeover remote control switch) .....	48			
16.2.5	To operate the system (WITH cool/heat changeover remote control switch) .....	48			
16.3	Using the dry program .....	48			
16.3.1	About the dry program .....	48			
16.3.2	To use the dry program (WITHOUT cool/heat changeover remote control switch) .....	48			
16.3.3	To use the dry program (WITH cool/heat changeover remote control switch) .....	49			
16.4	Adjusting the air flow direction .....	49			
16.4.1	About the air flow flap .....	49			
16.5	Setting the master user interface .....	49			
16.5.1	About setting the master user interface .....	49			
16.5.2	To designate the master user interface (VRV DX and Hydrobox) .....	49			
16.6	About control systems .....	49			
<b>17</b>	<b>Energy saving and optimum operation</b> .....	<b>49</b>			
17.1	Available main operation methods .....	50			
17.2	Available comfort settings .....	50			
<b>18</b>	<b>Maintenance and service</b> .....	<b>50</b>			
18.1	Maintenance after a long stop period .....	50			
18.2	Maintenance before a long stop period .....	51			
18.3	About the refrigerant .....	51			
18.4	After-sales service and warranty .....	51			
18.4.1	Warranty period .....	51			
18.4.2	Recommended maintenance and inspection .....	51			
18.4.3	Recommended maintenance and inspection cycles ..	51			
18.4.4	Shortened maintenance and replacement cycles .....	52			
<b>19</b>	<b>Troubleshooting</b> .....	<b>52</b>			
19.1	Error codes: Overview .....	52			
19.2	Symptoms that are NOT system malfunctions .....	52			
19.2.1	Symptom: The system does not operate .....	52			
19.2.2	Symptom: Cool/Heat cannot be changed over .....	53			
19.2.3	Symptom: Fan operation is possible, but cooling and heating do not work .....	53			
19.2.4	Symptom: The fan speed does not correspond to the setting .....	53			

# 1 General safety precautions



## NOTICE

Indicates a situation that could result in equipment or property damage.



## INFORMATION

Indicates useful tips or additional information.

Symbol	Explanation
	Before installation, read the installation and operation manual, and the wiring instruction sheet.
	Before performing maintenance and service tasks, read the service manual.
	For more information, see the installer and user reference guide.

## 1.2 For the user

- If you are NOT sure how to operate the unit, contact your installer.
- This appliance can be used by children aged from 8 years and above and persons with reduced physical, sensory or mental capabilities or lack of experience and knowledge if they have been given supervision or instruction concerning use of the appliance in a safe way and understand the hazards involved. Children shall NOT play with the appliance. Cleaning and user maintenance shall NOT be made by children without supervision.



## WARNING

To prevent electric shocks or fire:

- Do NOT rinse the unit.
- Do NOT operate the unit with wet hands.
- Do NOT place any objects containing water on the unit.



## NOTICE

- Do NOT place any objects or equipment on top of the unit.
- Do NOT sit, climb or stand on the unit.

- Units are marked with the following symbol:



This means that electrical and electronic products may NOT be mixed with unsorted household waste. Do NOT try to dismantle the system yourself: the dismantling of the system, treatment of the refrigerant, of oil and of other parts must be done by an authorized installer and must comply with applicable legislation. Units must be treated at a specialized treatment facility for reuse, recycling and recovery. By ensuring this product is disposed of correctly, you will help to prevent potential negative consequences for the environment and human health. For more information, contact your installer or local authority.

- Batteries are marked with the following symbol:



This means that the batteries may NOT be mixed with unsorted household waste. If a chemical symbol is printed beneath the symbol, this chemical symbol means that the battery contains a heavy metal above a certain concentration. Possible chemical symbols are: Pb: lead (>0.004%).

Waste batteries must be treated at a specialized treatment facility for reuse. By ensuring waste batteries are disposed of correctly, you will help to prevent potential negative consequences for the environment and human health.

## 1.3 For the installer

### 1.3.1 General

If you are NOT sure how to install or operate the unit, contact your dealer.



## NOTICE

Improper installation or attachment of equipment or accessories could result in electric shock, short-circuit, leaks, fire or other damage to the equipment. Only use accessories, optional equipment and spare parts made or approved by Daikin.



## WARNING

Make sure installation, testing and applied materials comply with applicable legislation (on top of the instructions described in the Daikin documentation).



## CAUTION

Wear adequate personal protective equipment (protective gloves, safety glasses,...) when installing, maintaining or servicing the system.



## WARNING

Tear apart and throw away plastic packaging bags so that nobody, especially children, can play with them. Possible risk: suffocation.



## DANGER: RISK OF BURNING

- Do NOT touch the refrigerant piping, water piping or internal parts during and immediately after operation. It could be too hot or too cold. Give it time to return to normal temperature. If you must touch it, wear protective gloves.
- Do NOT touch any accidental leaking refrigerant.



## WARNING

Provide adequate measures to prevent that the unit can be used as a shelter by small animals. Small animals that make contact with electrical parts can cause malfunctions, smoke or fire.



## CAUTION

Do NOT touch the air inlet or aluminium fins of the unit.



## NOTICE

- Do NOT place any objects or equipment on top of the unit.
- Do NOT sit, climb or stand on the unit.



## NOTICE

Works executed on the outdoor unit are best done under dry weather conditions to avoid water ingress.

In accordance with the applicable legislation, it might be necessary to provide a logbook with the product containing at least: information on maintenance, repair work, results of tests, stand-by periods,...

Also, at least, following information MUST be provided at an accessible place at the product:

- Instructions for shutting down the system in case of an emergency
- Name and address of fire department, police and hospital
- Name, address and day and night telephone numbers for obtaining service

In Europe, EN378 provides the necessary guidance for this logbook.

## 1.3.2 Installation site

- Provide sufficient space around the unit for servicing and air circulation.
- Make sure the installation site withstands the unit's weight and vibration.
- Make sure the area is well ventilated. Do NOT block any ventilation openings.
- Make sure the unit is level.

Do NOT install the unit in the following places:

- In potentially explosive atmospheres.
- In places where there is machinery that emits electromagnetic waves. Electromagnetic waves may disturb the control system, and cause malfunction of the equipment.
- In places where there is a risk of fire due to the leakage of flammable gases (example: thinner or gasoline), carbon fibre, ignitable dust.
- In places where corrosive gas (example: sulphurous acid gas) is produced. Corrosion of copper pipes or soldered parts may cause the refrigerant to leak.

## 1.3.3 Refrigerant

If applicable. See the installation manual or installer reference guide of your application for more information.



### NOTICE

Make sure refrigerant piping installation complies with applicable legislation. In Europe, EN378 is the applicable standard.



### NOTICE

Make sure the field piping and connections are NOT subjected to stress.



### WARNING

During tests, NEVER pressurize the product with a pressure higher than the maximum allowable pressure (as indicated on the nameplate of the unit).



### WARNING

Take sufficient precautions in case of refrigerant leakage. If refrigerant gas leaks, ventilate the area immediately. Possible risks:

- Excessive refrigerant concentrations in a closed room can lead to oxygen deficiency.
- Toxic gas may be produced if refrigerant gas comes into contact with fire.



### DANGER: RISK OF EXPLOSION

**Pump down – Refrigerant leakage.** If you want to pump down the system, and there is a leak in the refrigerant circuit:

- Do NOT use the unit's automatic pump down function, with which you can collect all refrigerant from the system into the outdoor unit. **Possible consequence:** Self-combustion and explosion of the compressor because of air going into the operating compressor.
- Use a separate recovery system so that the unit's compressor does NOT have to operate.



### WARNING

ALWAYS recover the refrigerant. Do NOT release them directly into the environment. Use a vacuum pump to evacuate the installation.



### NOTICE

After all the piping has been connected, make sure there is no gas leak. Use nitrogen to perform a gas leak detection.



### NOTICE



- To avoid compressor breakdown, do NOT charge more than the specified amount of refrigerant.
- When the refrigerant system is to be opened, refrigerant MUST be treated according to the applicable legislation.



### WARNING

Make sure there is no oxygen in the system. Refrigerant may only be charged after performing the leak test and the vacuum drying.

- In case re-charge is required, refer to the nameplate of the unit. It states the type of refrigerant and necessary amount.
- The unit is factory charged with refrigerant and depending on pipe sizes and pipe lengths some systems require additional charging of refrigerant.
- Only use tools exclusively for the refrigerant type used in the system, this to ensure pressure resistance and prevent foreign materials from entering into the system.
- Charge the liquid refrigerant as follows:

If	Then
A siphon tube is present (i.e., the cylinder is marked with "Liquid filling siphon attached")	Charge with the cylinder upright. 
A siphon tube is NOT present	Charge with the cylinder upside down. 

- Open refrigerant cylinders slowly.
- Charge the refrigerant in liquid form. Adding it in gas form may prevent normal operation.



### CAUTION

When the refrigerant charging procedure is done or when pausing, close the valve of the refrigerant tank immediately. If the valve is NOT closed immediately, remaining pressure might charge additional refrigerant. **Possible consequence:** Incorrect refrigerant amount.

## 1.3.4 Brine

If applicable. See the installation manual or installer reference guide of your application for more information.



### WARNING

The selection of the brine MUST be in accordance with the applicable legislation.

# 1 General safety precautions

## WARNING

Take sufficient precautions in case of brine leakage. If brine leaks, ventilate the area immediately and contact your local dealer.

## WARNING

The ambient temperature inside the unit can get much higher than that of the room, e.g. 70°C. In case of a brine leak, hot parts inside the unit can create a hazardous situation.

## WARNING

The use and installation of the application MUST comply with the safety and environmental precautions specified in the applicable legislation.

### 1.3.5 Water

If applicable. See the installation manual or installer reference guide of your application for more information.

## NOTICE

Make sure water quality complies with EU directive 98/83 EC.

### 1.3.6 Electrical

## DANGER: RISK OF ELECTROCUTION

- Turn OFF all power supply before removing the switch box cover, connecting electrical wiring or touching electrical parts.
- Disconnect the power supply for more than 1 minute, and measure the voltage at the terminals of main circuit capacitors or electrical components before servicing. The voltage MUST be less than 50 V DC before you can touch electrical components. For the location of the terminals, see the wiring diagram.
- Do NOT touch electrical components with wet hands.
- Do NOT leave the unit unattended when the service cover is removed.

## WARNING

If NOT factory installed, a main switch or other means for disconnection, having a contact separation in all poles providing full disconnection under overvoltage category III condition, MUST be installed in the fixed wiring.

## WARNING

- ONLY use copper wires.
- Make sure the field wiring complies with the applicable legislation.
- All field wiring MUST be performed in accordance with the wiring diagram supplied with the product.
- NEVER squeeze bundled cables and make sure they do NOT come in contact with the piping and sharp edges. Make sure no external pressure is applied to the terminal connections.
- Make sure to install earth wiring. Do NOT earth the unit to a utility pipe, surge absorber, or telephone earth. Incomplete earth may cause electrical shock.
- Make sure to use a dedicated power circuit. NEVER use a power supply shared by another appliance.
- Make sure to install the required fuses or circuit breakers.
- Make sure to install an earth leakage protector. Failure to do so may cause electric shock or fire.
- When installing the earth leakage protector, make sure it is compatible with the inverter (resistant to high frequency electric noise) to avoid unnecessary opening of the earth leakage protector.

## NOTICE

Precautions when laying power wiring:



- Do NOT connect wiring of different thicknesses to the power terminal block (slack in the power wiring may cause abnormal heat).
- When connecting wiring which is the same thickness, do as shown in the figure above.
- For wiring, use the designated power wire and connect firmly, then secure to prevent outside pressure being exerted on the terminal board.
- Use an appropriate screwdriver for tightening the terminal screws. A screwdriver with a small head will damage the head and make proper tightening impossible.
- Over-tightening the terminal screws may break them.

Install power cables at least 1 m away from televisions or radios to prevent interference. Depending on the radio waves, a distance of 1 m may not be sufficient.

## WARNING

- After finishing the electrical work, confirm that each electrical component and terminal inside the electrical components box is connected securely.
- Make sure all covers are closed before starting up the unit.

## NOTICE

Only applicable if the power supply is three-phase, and the compressor has an ON/OFF starting method.

If there exists the possibility of reversed phase after a momentary black out and the power goes on and off while the product is operating, attach a reversed phase protection circuit locally. Running the product in reversed phase can break the compressor and other parts.

## 2 About the documentation

### 2.1 About this document

**Target audience**

Authorised installers + end users

**Documentation set**

This document is part of a documentation set. The complete set consists of:

- **General safety precautions:**
  - Safety instructions that you must read before installing
  - Format: Paper (in the box of the outdoor unit)
- **Outdoor unit installation and operation manual:**
  - Installation and operation instructions
  - Format: Paper (in the box of the outdoor unit)

▪ **Installer and user reference guide:**

- Preparation of the installation, reference data,...
- Detailed step-by-step instructions and background information for basic and advanced usage
- Format: Digital files on <http://www.daikineurope.com/support-and-manuals/product-information/>

Latest revisions of the supplied documentation may be available on the regional Daikin website or via your dealer.

The original documentation is written in English. All other languages are translations.

**Technical engineering data**

- A **subset** of the latest technical data is available on the regional Daikin website (publicly accessible).
- The **full set** of latest technical data is available on the Daikin extranet (authentication required).

## For the installer

## 3 About the box

### 3.1 Overview: About the box

This chapter describes what you have to do after the box with the outdoor unit is delivered on-site.

It contains information about:

- Unpacking and handling the outdoor unit
- Removing the accessories from the unit
- Removing the transportation stay

Keep the following in mind:

- At delivery, the unit **MUST** be checked for damage. Any damage **MUST** be reported immediately to the carrier's claims agent.
- Bring the packed unit as close as possible to its final installation position to prevent damage during transport.
- When handling the unit, take into account the following:

 Fragile, handle the unit with care.

 Keep the unit upright in order to avoid compressor damage.

- Prepare the path along which you want to bring the unit inside in advance.
- Lift the unit preferably with a crane and 2 belts of at least 5 m long as shown in the figure below. Always use protectors to prevent belt damage and pay attention to the position of the unit's centre of gravity.

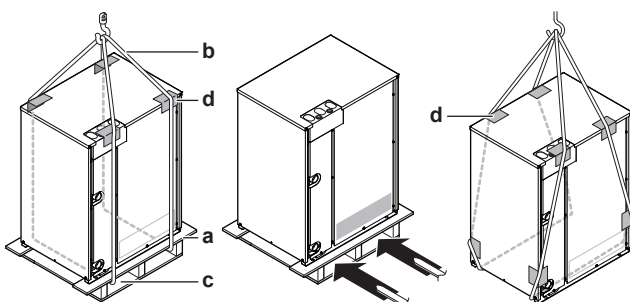

- a Packaging material
- b Belt sling
- c Opening
- d Protector



**NOTICE**

Use a belt sling of ≤20 mm wide that adequately bears the weight of the unit.

- A forklift can only be used for transport as long as the unit remains on its pallet as shown above.

### 3.2 To unpack the outdoor unit

Remove the packaging material from the unit:

- Take care not to damage the unit when removing the shrink foil with a cutter.
- Remove the 4 bolts fixing the unit to its pallet.



**WARNING**

Tear apart and throw away plastic packaging bags so that nobody, especially children, can play with them. Possible risk: suffocation.

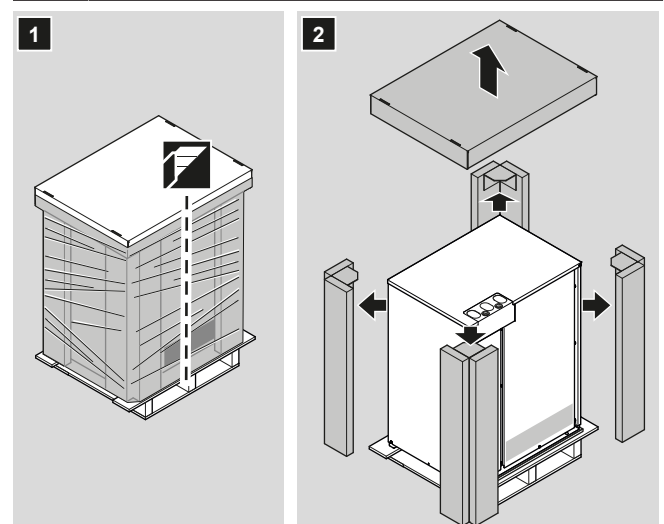

### 3 About the box

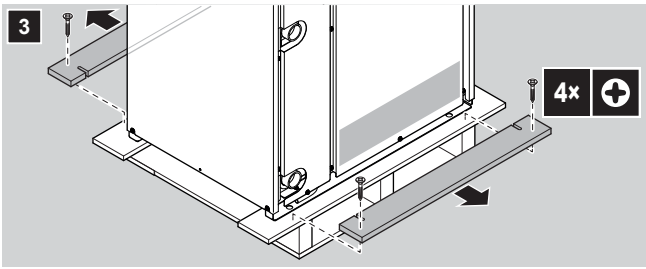

### 3.3 To remove the accessories from the outdoor unit

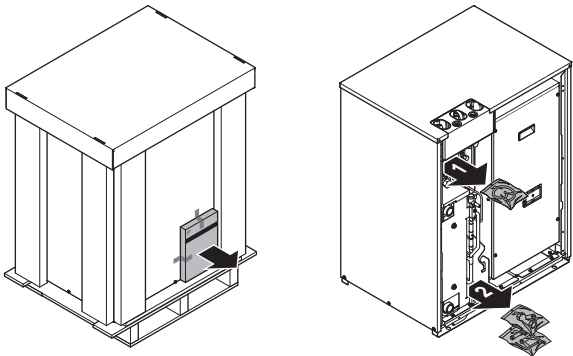

Make sure that all accessories are available in the unit.

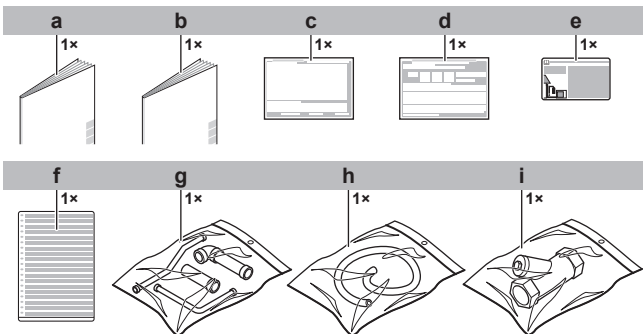

- a General safety precautions
- b Installation manual and operation manual
- c Additional refrigerant charge label
- d Installation information sticker
- e Fluorinated greenhouse gases label
- f Multilingual fluorinated greenhouse gases label
- g Piping accessory bag
- h Hose
- i Water filter

### 3.4 Accessory pipes: Diameters

Accessory pipes (mm)	HP	Øa	Øb	Øc	Ød
Liquid pipe	8	12.7	12.7	12.7	9.5
	10				
	12				
	14				
• Front connection <sup>(a)</sup>					12.7
• Top connection					

Accessory pipes (mm)	HP	Øa	Øb	Øc	Ød
Gas pipe	8	25.4	25.4	25.4	19.1
	10				
	12				
	14				
• Front connection <sup>(a)</sup>					22.2
• Top connection					28.6
High pressure/Low pressure gas pipe	8	25.4	25.4	25.4	15.9
	10				
	12				
	14				
• Front connection <sup>(a)</sup>					19.1
• Top connection					22.2

(a) Braze the straight accessory pipe onto the L-shaped accessory pipe in order to get the correct diameter to connect the field pipes (for front connection).

### 3.5 To remove the transportation stay



#### NOTICE

If the unit is operated with the transportation stay attached, abnormal vibration or noise may be generated.

The compressor transportation stay must be removed. It is installed under the compressor leg in order to protect the unit during transport. Proceed as shown in the figure and procedure below.

- 1 Remove the bolt.
- 2 Lift the insulation to access the compressor mounting bolt.
- 3 Slightly loosen the mounting bolt.
- 4 Remove the transportation stay as shown in the figure below.
- 5 Tighten the mounting bolt to 12.3 N•m of torque.

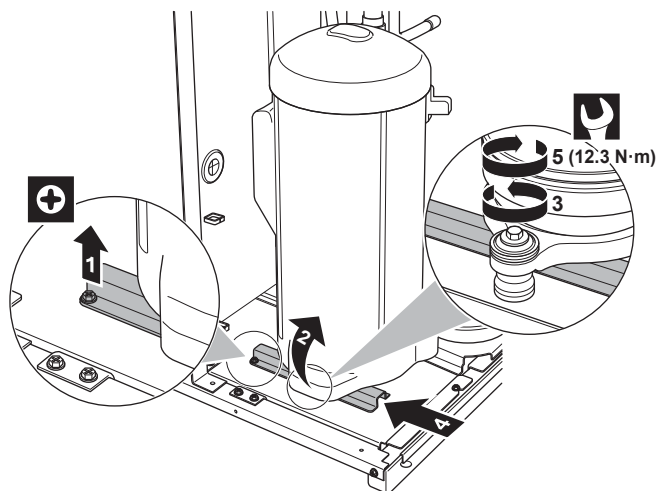



## 4 About the units and options

### 4.1 Overview: About the units and options

This chapter contains information about:

- Identification of the outdoor unit
- Where the outdoor unit fits in the system layout
- With which indoor units and options you can combine the outdoor units
- Which outdoor units have to be used as standalone units, and which outdoor units can be combined

### 4.2 Identification label: Outdoor unit

Location

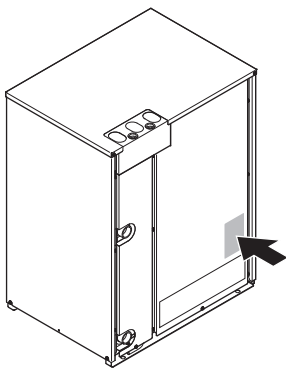

Model identification

Example: RW E Y Q 8 T9 Y1 B [\*]

Code	Explanation
RW	Water-cooled
E	Heat pump system
Y	Heat recovery system
Q	Refrigerant R410A
8	Capacity class
T9	Model series
Y1	Power supply
B	European market
[*]	Minor model change indication

### 4.3 About the outdoor unit

This installation manual concerns the VRV IV water-cooled system air conditioner. The unit is full inverter driven, and can be used for cooling, heat pump and heat recovery applications.

Model line up:

Model	Description
RWEYQ8~14	Heat recovery model for single or multi-use

Depending on the chosen type of unit, some functionality will or will not exist. It will be indicated throughout this installation manual and brought to your attention. Certain features have exclusive model rights.

These units are intended for indoor installation and aimed for heat pump applications including water to air and water to water applications.

These units have (in single use) heating capacities ranging from 25 to 45 kW and cooling capacities ranging from 22.4 to 40 kW. When multi combination is used, the capacity can go up to 135 kW for heating and 120 kW for cooling.

The unit is designed to work in heating mode at indoor temperatures from 15°C WB to 27°C WB and in cooling mode at indoor temperatures from 21°C DB to 32°C DB or 14°C WB to 25°C WB.

The ambient temperature around the unit should be above 0°C DB and below 40°C DB. Relative humidity around the unit should be below 80%.

The water temperature at the water inlet of the unit must be between 10°C and 45°C. The lower limit is extendable down to -10°C (heating operation mode) in case the brine type setting [2-50] is set for use with brine as heat source medium.

### 4.4 System layout



#### INFORMATION

Not all combinations of indoor units are allowed, for guidance, see "4.5.2 Possible combinations of indoor units" on page 10.

#### Heat pump system

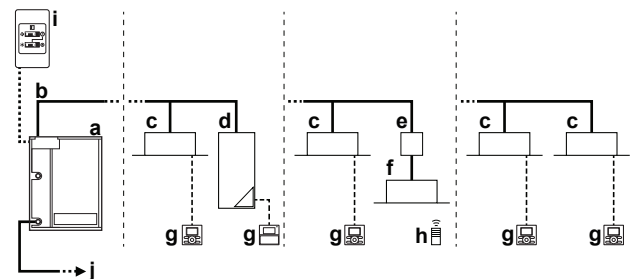

- a Unit
- b Refrigerant piping
- c VRV DX indoor unit
- d LT Hydrobox unit
- e BP box (required to connect Residential Air (RA) or Sky Air (SA) direct expansion (DX) indoor units)
- f Residential Air (RA) direct expansion (DX) indoor units
- g User interface
- h Wireless user interface
- i Cool/heat changeover remote control switch
- j Water system connection

## 4 About the units and options

### Heat recovery system

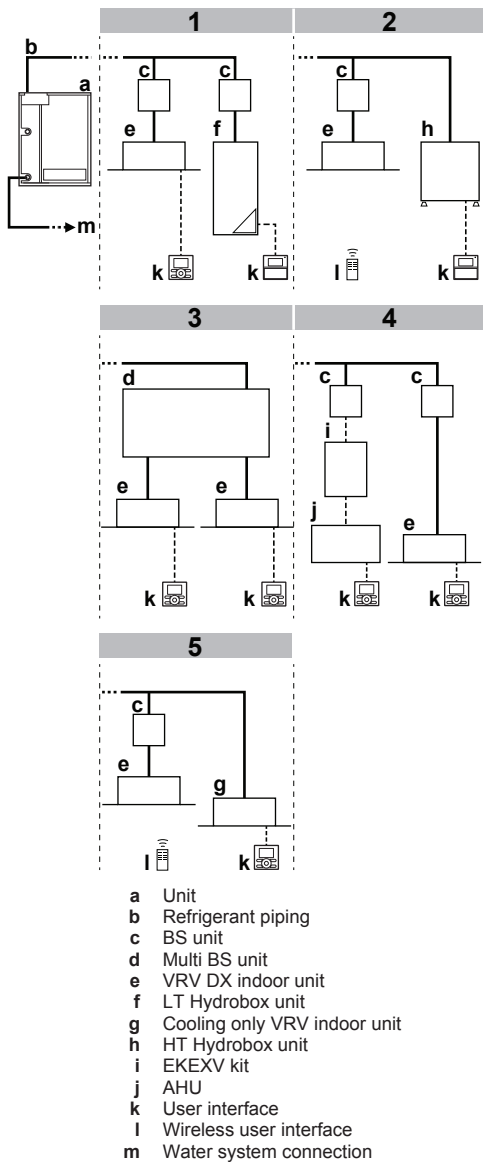

### Water system

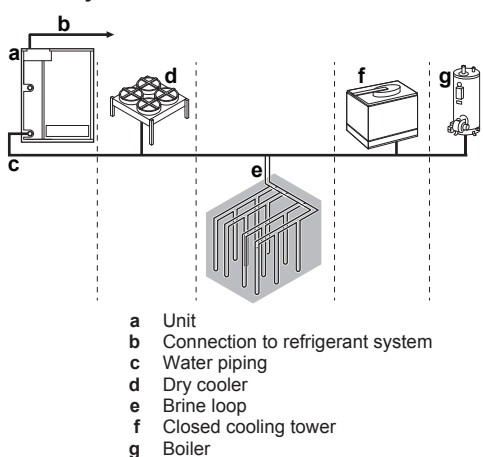

## 4.5 Combining units and options

### 4.5.1 About combining units and options



#### NOTICE

To be sure your system setup (unit+indoor unit(s)) will work, you have to consult the latest technical engineering data for VRV IV water-cooled.

The VRV IV water cooled system can be combined with several types of indoor units and is intended for R410A use only.

For an overview which units are available you can consult the product catalogue for VRV IV.

An overview is given indicating the allowed combinations of indoor units and outdoor units. Not all combinations are allowed. They are subject to rules (combination between outdoor-indoor, single outdoor unit use, multiple outdoor unit use, combinations between indoor units, etc.) mentioned in the technical engineering data.

### 4.5.2 Possible combinations of indoor units

In general following type of indoor units can be connected to a VRV IV heat recovery system. The list is non-exhaustive and is depending on both outdoor unit model and indoor unit model combinations.

For more information, see "5.3.5 Single outdoor units and standard multi-outdoor-unit combinations" on page 16.

- VRV direct expansion (DX) indoor units (air-to-air applications).
- HT (high temperature) Hydrobox (air-to-water applications): HXHD series (heating only).
- LT (low temperature) Hydrobox (air-to-water applications): HXY080/125 series.
- AHU (air-to-air applications): EKEXV-kit+EKEQM-box required, depending on the application.
- Comfort air curtain (air-to-air applications): CYVS (Biddle) series.

### 4.5.3 Possible combinations of outdoor units

#### Possible standalone units

RWEYQ8
RWEYQ10
RWEYQ12
RWEYQ14

#### Possible standard combinations of units

RWEYQ16~42 consists of 2 or 3 RWEYQ8~14 units.

RWEYQ16 = RWEYQ8 + 8
RWEYQ18 = RWEYQ8 + 10
RWEYQ20 = RWEYQ10 + 10
RWEYQ22 = RWEYQ10 + 12
RWEYQ24 = RWEYQ12 + 12
RWEYQ26 = RWEYQ12 + 14
RWEYQ28 = RWEYQ14 + 14
RWEYQ30 = RWEYQ10 + 10 + 10
RWEYQ32 = RWEYQ10 + 10 + 12
RWEYQ34 = RWEYQ10 + 12 + 12
RWEYQ36 = RWEYQ12 + 12 + 12
RWEYQ38 = RWEYQ12 + 12 + 14
RWEYQ40 = RWEYQ12 + 14 + 14
RWEYQ42 = RWEYQ14 + 14 + 14

#### 4.5.4 Possible options for the outdoor unit



##### INFORMATION

Refer to the technical engineering data for the latest option names.

##### Refrigerant branching kit

In case of heat pump system	
Description	Model name
Refnet header	KHRQ22M29H
	KHRQ22M64H
	KHRQ22M75H
Refnet joint	KHRQ22M20T
	KHRQ22M29T9
	KHRQ22M64T
	KHRQ22M75T

In case of heat recovery system	
Description	Model name
Refnet header	KHRQ23M29H
	KHRQ23M64H
	KHRQ23M75H
Refnet joint	KHRQ23M20T
	KHRQ23M29T9
	KHRQ23M64T
	KHRQ23M75T

##### Outdoor multi connection piping kit

In case of heat pump system	
Number of outdoor units	Model name
2	BHFQ22P1007
3	BHFQ22P1517

In case of heat recovery system	
Number of outdoor units	Model name
2	BHFQ23P907
3	BHFQ23P1357

##### Cool/heat selector

In order to control the cooling or heating operation from a central location, the following option can be connected:

Description	Model name
Cool/heat changeover switch	KRC19-26A
Cool/heat changeover PCB	BRP2A81
With optional fixing box for the switch	KJB111A



##### INFORMATION

The cool/heat selector can only be used when the refrigerant system is configured as heat pump system.

##### External control adaptor (DTA104A61/62)

To instruct specific operation with an external input coming from a central control the external control adaptor can be used. Instructions (group or individual) can be instructed for low noise operation and power consumption limitation operation.

##### PC configurator cable (EKPCAB)

You can make several commissioning field settings through a personal computer interface. For this option EKPCAB is required which is a dedicated cable to communicate with the outdoor unit. The user interface software is available on <http://www.daikineurope.com/support-and-manuals/software-downloads/>.

##### Demand PCB (EKRP1AHTA)

To enable the power saving consumption control by digital inputs you must install the demand PCB.

For installation instructions, see the installation manual of the demand PCB and addendum book for optional equipment.

## 5 Preparation

### 5.1 Overview: Preparation

This chapter describes what you have to do and know before going on-site.

It contains information about:

- Preparing the installation site
- Preparing the water piping
- Preparing the refrigerant piping
- Preparing the electrical wiring

### 5.2 Preparing the installation site

#### 5.2.1 Installation site requirements of the outdoor unit

- Provide sufficient space around the unit for servicing and air circulation.
- Make sure the installation site withstands the unit's weight and vibration.
- Make sure the area is well ventilated. Do NOT block any ventilation openings.
- Make sure the unit is level.
- Make sure to install the unit in a machine room that is free of moisture. The unit is designed for indoor use only.
- Select the location of the unit in such a way that the sound generated by the unit does not disturb anyone, and the location is selected according the applicable legislation.

Do NOT install the unit in the following places:

- In potentially explosive atmospheres.
- In places where there is machinery that emits electromagnetic waves. Electromagnetic waves may disturb the control system, and cause malfunction of the equipment.
- In places where there is a risk of fire due to the leakage of flammable gases (example: thinner or gasoline), carbon fibre, ignitable dust.
- In places where corrosive gas (example: sulphurous acid gas) is produced. Corrosion of copper pipes or soldered parts may cause the refrigerant to leak.
- In places where a mineral oil mist, spray or vapour may be present in the atmosphere. Plastic parts may deteriorate and fall off or cause water leakage.



##### NOTICE

This equipment is compliant with Class A of EN55032/ CISPR 32. In a residential environment this equipment may cause radio interference.

## 5 Preparation

### NOTICE

The equipment described in this manual may cause electronic noise generated from radio-frequency energy. The equipment complies to specifications that are designed to provide reasonable protection against such interference. However, there is no guarantee that interference will not occur in a particular installation.

It is therefore recommended to install the equipment and electric wires keeping proper distances away from stereo equipment, personal computers, etc.

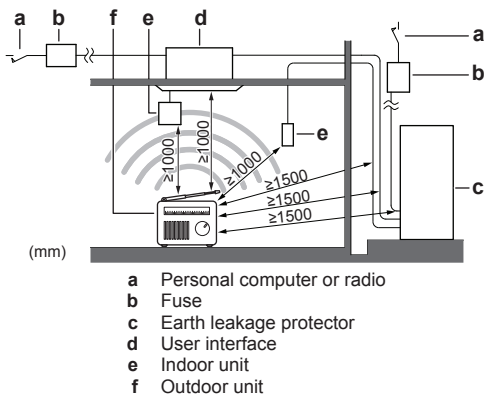

In places with weak reception, keep distances of 3 m or more to avoid electromagnetic disturbance of other equipment and use conduit tubes for power and transmission lines.

### CAUTION

Appliance not accessible to the general public, install it in a secured area, protected from easy access.

This unit, both indoor and outdoor, is suitable for installation in a commercial and light industrial environment.

- When installing, take strong winds, typhoons or earthquakes into account, improper installation may result in the unit turning over.
- Take care that in the event of a water leak, water cannot cause any damage to the installation space and surroundings.
- When installing the unit in a small room, take measures in order to keep the refrigerant concentration from exceeding allowable safety limits in the event of a refrigerant leak, refer to "[About safety against refrigerant leaks](#)" on page 12.

### CAUTION

Excessive refrigerant concentrations in a closed room can lead to oxygen deficiency.

- Ensure that water cannot cause any damage to the location by adding water drains to the foundation and prevent water traps in the construction.
- Install drain piping to ensure proper drainage and insulate piping to prevent condensation. Improper drain piping may result in indoor water leakage and property damage.

### 5.2.2 Securing safety against refrigerant leaks

#### About safety against refrigerant leaks

The installer and system specialist shall secure safety against leakage according to local regulations or standards. The following standards may be applicable if local regulations are not available.

This system uses R410A as refrigerant. R410A itself is an entirely safe non-toxic, non-combustible refrigerant. Nevertheless care must be taken to ensure that the system is installed in a room which is sufficiently large. This assures that the maximum concentration level

of refrigerant gas is not exceeded, in the unlikely event of major leak in the system and this in accordance to the local applicable regulations and standards.

#### About the maximum concentration level

The maximum charge of refrigerant and the calculation of the maximum concentration of refrigerant is directly related to the humanly occupied space in to which it could leak.

The unit of measurement of the concentration is kg/m<sup>3</sup> (the weight in kg of the refrigerant gas in 1 m<sup>3</sup> volume of the occupied space).

Compliance to the local applicable regulations and standards for the maximum allowable concentration level is required.

According to the appropriate European Standard, the maximum allowed concentration level of refrigerant to a humanly space for R410A is limited to 0.44 kg/m<sup>3</sup>.

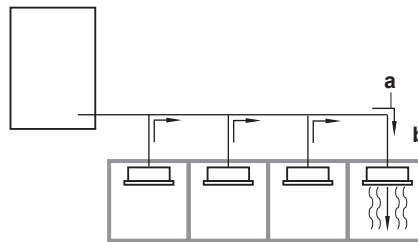

- a Direction of the refrigerant flow
- b Room where refrigerant leak has occurred (outflow of all the refrigerant from the system)

Pay special attention to places such as basements etc., where refrigerant can accumulate, since refrigerant is heavier than air.

#### To check the maximum concentration level

Check the maximum concentration level in accordance with steps 1 to 4 below and take whatever action is necessary to comply.

- 1 Calculate the amount of refrigerant (kg) charged to each system separately.

Formula: **A+B=C**

- A Amount of refrigerant in a single unit system (amount of refrigerant with which the system is charged before leaving the factory).
- B Additional charging amount (amount of refrigerant added locally).
- C Total amount of refrigerant (kg) in the system.

### NOTICE

Where a single refrigerant facility is divided into 2 entirely independent refrigerant systems, use the amount of refrigerant with which each separate system is charged.

- 2 Calculate the volume of the room (m<sup>3</sup>) where the indoor unit is installed. In one of the following cases, calculate the volume of (D), (E) as a single room or as the smallest room:

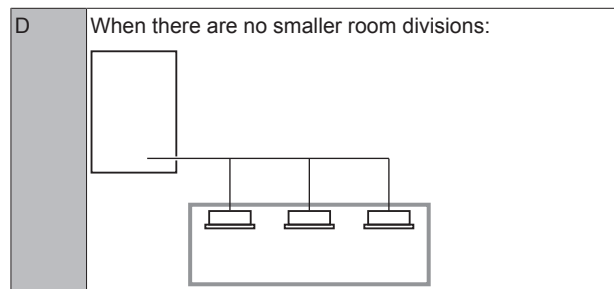

**E** When there is a room division that has an opening sufficiently large to permit free air flow.

**a** Opening between the rooms. In case there is a door the openings above and below the door each must be equivalent in size to 0.15% or more of the floor area.

**b** Room division

- Calculate the refrigerant density using the results of the calculations in steps 1 and 2 above. If the result of the above calculation exceeds the maximum concentration level, a ventilation opening to the adjacent room shall be made.

Formula:  $F/G \leq H$

- F** Total volume of refrigerant in the refrigerant system.
- G** Size (m<sup>3</sup>) of smallest room in which there is an indoor unit installed.
- H** Maximum concentration level (kg/m<sup>3</sup>).

- Calculate the refrigerant density using the total volume of the room where the indoor unit is installed and the adjacent room. Install ventilation openings in other doors of adjacent rooms until the resulting refrigerant density is smaller than the maximum concentration level.

## 5.3 Preparing refrigerant piping

### 5.3.1 Refrigerant piping requirements



#### NOTICE

The refrigerant R410A requires strict cautions for keeping the system clean, dry and tight.

- Clean and dry: foreign materials (including mineral oils or moisture) should be prevented from getting mixed into the system.
- Tight: R410A does not contain any chlorine, does not destroy the ozone layer, and does not reduce earth's protection against harmful ultraviolet radiation. R410A can contribute slightly to the greenhouse effect if it is released. Therefore pay special attention to check the tightness of the installation.



#### NOTICE

The piping and other pressure-containing parts shall be suitable for refrigerant. Use phosphoric acid deoxidised seamless copper for refrigerant.

- Foreign materials inside pipes (including oils for fabrication) must be  $\leq 30$  mg/10 m.
- Temper grade: use piping with temper grade in function of the pipe diameter as listed in table below.

Pipe Ø	Temper grade of piping material
$\leq 15.9$ mm	O (annealed)
$\geq 19.1$ mm	1/2H (half hard)

- All piping lengths and distances have been taken into consideration (see "5.3.4 About the piping length" on page 15).
- The pipe thickness of the refrigerant piping shall comply with the applicable legislation. The minimal pipe thickness for R410A piping must be in accordance with the table below.

Pipe Ø	Minimal thickness t
6.4 mm/9.5 mm/12.7 mm	0.80 mm
15.9 mm	0.99 mm
19.1 mm/22.2 mm	0.80 mm
28.6 mm	0.99 mm
34.9 mm	1.21 mm
41.3 mm	1.43 mm

- In case the required pipe sizes (inch sizes) are not available, it is also allowed to use other diameters (mm sizes), taken the following into account:
  - Select the pipe size nearest to the required size.
  - Use the suitable adapters for the change-over from inch to mm pipes (field supply).
  - The additional refrigerant calculation has to be adjusted as mentioned in "6.6.3 To determine the additional refrigerant amount" on page 29.

### 5.3.2 To select the piping size



#### INFORMATION

Please select the proper pipe sizes depending on the mode of your system. There are 2 possible modes:

- heat pump,
- heat recovery.

Determine the proper size using the following tables and reference figure (only for indication).

#### In case of heat pump system

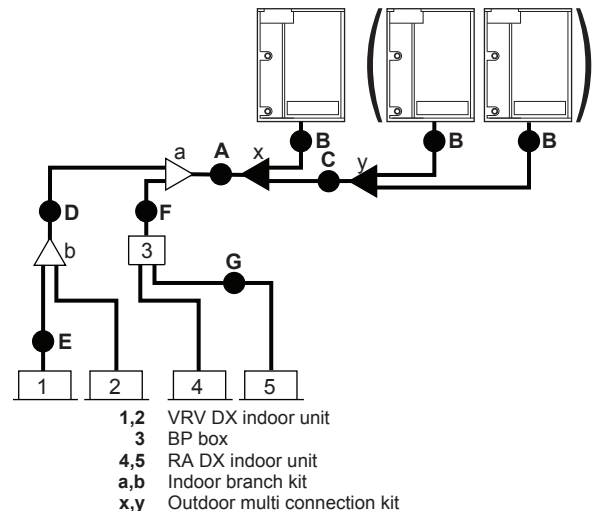

#### In case of heat recovery system

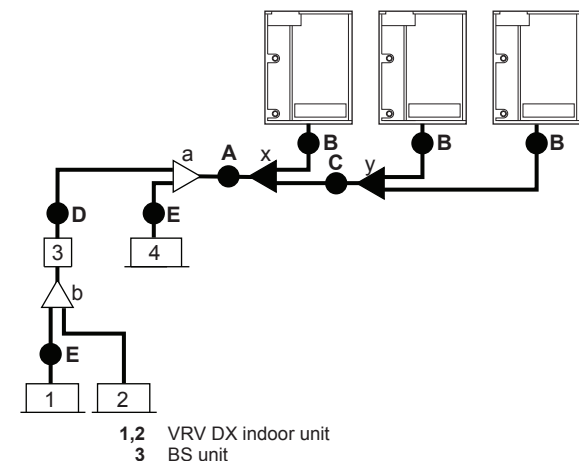

## 5 Preparation

- 4 Cooling only VRV indoor unit
- A~E Piping
- a,b Indoor branch kit
- x,y Outdoor multi connection kit

### A, B, C: Piping between outdoor unit and (first) refrigerant branch kit

Choose from the following table in accordance with the outdoor unit total capacity type, connected downstream.

#### In case of heat pump system

Outdoor unit capacity type (HP)	Piping outer diameter size (mm)	
	Gas pipe	Liquid pipe
8	19.1	9.5
10	22.2	
12~16	28.6	12.7
18~22		15.9
24	34.9	19.1
26~34		
36~42	41.3	

#### In case of heat recovery system

Outdoor unit capacity type (HP)	Piping outer diameter size (mm)		
	Liquid pipe	Suction gas pipe	High pressure/low pressure gas pipe
8	9.5	19.1	15.9
10		22.2	19.1
12	12.7	28.6	22.2
14~16			
18	15.9	34.9	28.6
20~22			
24	19.1	41.3	34.9
26~34			
36			
38~42			

### D: Piping between refrigerant branch kits or refrigerant branch kit and BS unit

Choose from the following table in accordance with the indoor unit total capacity type, connected downstream. Do not let the connection piping exceed the refrigerant piping size chosen by the general system model name.

#### In case of heat pump system

Indoor unit capacity index	Piping outer diameter size (mm)	
	Gas pipe	Liquid pipe
<150	15.9	9.5
150≤x<200	19.1	
200≤x<290	22.2	
290≤x<420	28.6	12.7
420≤x<640		15.9
640≤x<920	34.9	19.1
≥920	41.3	

#### In case of heat recovery system

Indoor unit capacity index	Piping outer diameter size (mm)		
	Liquid pipe	Suction gas pipe	High pressure/low pressure gas pipe
<150	9.5	15.9	12.7
150≤x<200		19.1	15.9
200≤x<290		22.2	19.1
290≤x<420	12.7	28.6	28.6
420≤x<640	15.9		
640≤x<920	19.1	34.9	
≥920		41.3	

#### Example:

- Downstream capacity for E=[capacity index of unit 1]
- Downstream capacity for D=[capacity index of unit 1]+[capacity index of unit 2]

### E: Piping between refrigerant branch kit or BS unit and indoor unit

#### For heat pump and heat recovery system

Pipe size for direct connection to indoor unit must be the same as the connection size of the indoor unit.

Indoor unit capacity index	Piping outer diameter size (mm)	
	Gas pipe	Liquid pipe
15~50	12.7	6.4
63~140	15.9	9.5
200	19.1	
250	22.2	

- If a size-up of the piping is required, refer to the table below.

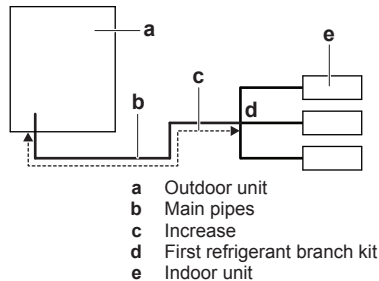

- a Outdoor unit
- b Main pipes
- c Increase
- d First refrigerant branch kit
- e Indoor unit

Size up	
HP class	Liquid piping outer diameter size (mm)
8	9.5 → 12.7
10	
12+14	12.7 → 15.9
16	
18~22	15.9 → 19.1
24	
26~34	19.1 → 22.2
36~42	

### F: Piping between refrigerant branch kit and BP unit

#### Heat pump system in case of single outdoor unit

Pipe size for direct connection on BP unit must be based on the total capacity of the connected indoor units (only in case RA DX indoor units are connected).

Total capacity index of connected indoor units	Piping outer diameter size (mm)	
	Gas pipe	Liquid pipe
20~62	12.7	6.4
63~149	15.9	9.5
150~208	19.1	

**Example:**

Downstream capacity for  $F=[\text{capacity index of unit 4}]+[\text{capacity index of unit 5}]$

**G: Piping between BP unit and RA DX indoor unit****Heat pump system in case of single outdoor unit**

Only in case RA DX indoor units are connected.

Indoor unit capacity index	Piping outer diameter size (mm)	
	Gas pipe	Liquid pipe
20, 25, 30	9.5	6.4
50	12.7	
60		9.5
71	15.9	

**5.3.3 To select refrigerant branch kits****Refrigerant refnets**

For piping example, refer to "5.3.2 To select the piping size" on page 13.

- When using refnet joints at the first branch counted from the outdoor unit side, choose from the following table in accordance with the capacity of the outdoor unit (example: refnet joint a).

Outdoor unit capacity type (HP)	2 pipes	3 pipes
8~10	KHRQ22M29T9	KHRQ23M29T9
12~22	KHRQ22M64T	KHRQ23M64T
24~42	KHRQ22M75T	KHRQ23M75T

- For refnet joints other than the first branch (example refnet joint b), select the proper branch kit model based on the total capacity index of all indoor units connected after the refrigerant branch.

Indoor unit capacity index	2 pipes	3 pipes
<200	KHRQ22M20T	KHRQ23M20T
$200 \leq x < 290$	KHRQ22M29T9	KHRQ23M29T9
$290 \leq x < 640$	KHRQ22M64T	KHRQ23M64T
$\geq 640$	KHRQ22M75T	KHRQ23M75T

- Concerning refnet headers, choose from the following table in accordance with the total capacity of all the indoor units connected below the refnet header.

Indoor unit capacity index	2 pipes	3 pipes
<200	KHRQ22M29H	KHRQ23M29H
$200 \leq x < 290$		
$290 \leq x < 640$	KHRQ22M64H <sup>(a)</sup>	KHRQ23M64H <sup>(a)</sup>
$\geq 640$	KHRQ22M75H	KHRQ23M75H

(a) If the pipe size above the refnet header is  $\geq 34.9$  mm or more, KHRQ22M75H is required.

**INFORMATION**

Maximum 8 branches can be connected to a header.

- How to choose an outdoor multi connection piping kit. Choose from the following table in accordance with the number of outdoor units.

Number of outdoor units	Branch kit name
2	BHFQ22P1007
3	BHFQ22P1517

**INFORMATION**

Reducers or T-joints are field supplied.

**NOTICE**

Refrigerant branch kits can only be used with R410A.

**5.3.4 About the piping length**

Make sure the piping installation does not exceed the maximum allowable pipe length, the allowable level difference, and the allowable length after branching. To illustrate the piping length requirements, 6 cases are discussed in the chapters below. They describe both standard and non-standard outdoor unit combinations.

**Definitions**

Term	Definition
Actual piping length	Pipe length between outdoor <sup>(a)</sup> and indoor units
Equivalent piping length	Pipe length between outdoor <sup>(a)</sup> and indoor units, including the equivalent length of the piping accessories
Total piping length	Total piping length, from the outdoor to all indoor units

(a) If the system is a multi outdoor installation, re-read "the first outdoor unit branch as seen from the indoor unit".

**Equivalent length of the piping accessories**

Accessory	Equivalent length
Refnet joint	0.5 m
Refnet header	1 m
Single BS1Q100~160	4 m
Single BS1Q25	6 m
Multi BS4~16Q14	4 m

**Allowable height difference**

Term	Definition	Distance
Actual piping length	Pipe length between outdoor <sup>(a)</sup> and indoor units	165 m
Equivalent piping length <sup>(b)</sup>	Pipe length between outdoor <sup>(a)</sup> and indoor units	190 m
Total piping length	Total piping length from the outdoor <sup>(a)</sup> to all indoor units	300 m
H1	Height difference between outdoor and indoor units	50/40 m <sup>(b)</sup>
H2	Height difference between indoor units	15 m 30 m <sup>(c)</sup>
H3	Height difference between outdoor units	5 m
H4	Height difference between outdoor unit and BP unit.	40 m
H5	Height difference between BP units	15 m
H6	Height difference between BP unit and RA DX indoor unit	5 m
H7	Height difference between EKEXV-kits and AHU units	5 m

## 5 Preparation

- (a) If the system capacity is a multi outdoor installation, re-read "the first outdoor branch as seen from the indoor unit".
- (b) The allowable height difference is 50 m in case the outdoor unit is positioned higher than the indoor unit, and 40 m in case the outdoor unit is positioned lower than the indoor unit.
- (c) If the outdoor unit is connected to VRV DX indoor units only, the height difference between indoor units (H2) can be increased to 30 m. In all other cases, the H2 is limited to 15 m.

If	Then
The outdoor unit is positioned higher than the indoor units	<ul style="list-style-type: none"> <li>▪ Minimum connection ratio: 80%</li> <li>▪ Size up the liquid piping (refer to "5.3.2 To select the piping size" on page 13 for more information)</li> <li>▪ Activate the outdoor unit setting. Refer to the service manual for more information.</li> </ul>
The outdoor unit is positioned lower than the indoor units	<ul style="list-style-type: none"> <li>▪ Minimum connection ratio varies according to the height difference between outdoor and indoor units:                             <ul style="list-style-type: none"> <li>▪ 40~60 m: 80%</li> <li>▪ 60~65 m: 90%</li> <li>▪ 65~80 m: 100%</li> <li>▪ 80~90 m: 110%</li> </ul> </li> <li>▪ Size up the liquid piping (refer to "5.3.2 To select the piping size" on page 13 for more information)</li> <li>▪ Activate the outdoor unit setting. Refer to the service manual for more information.</li> <li>▪ No technical cooling</li> </ul>

### 5.3.5 Single outdoor units and standard multi-outdoor-unit combinations

#### In case of heat pump system

##### Connection with VRV DX indoor units and air handling units

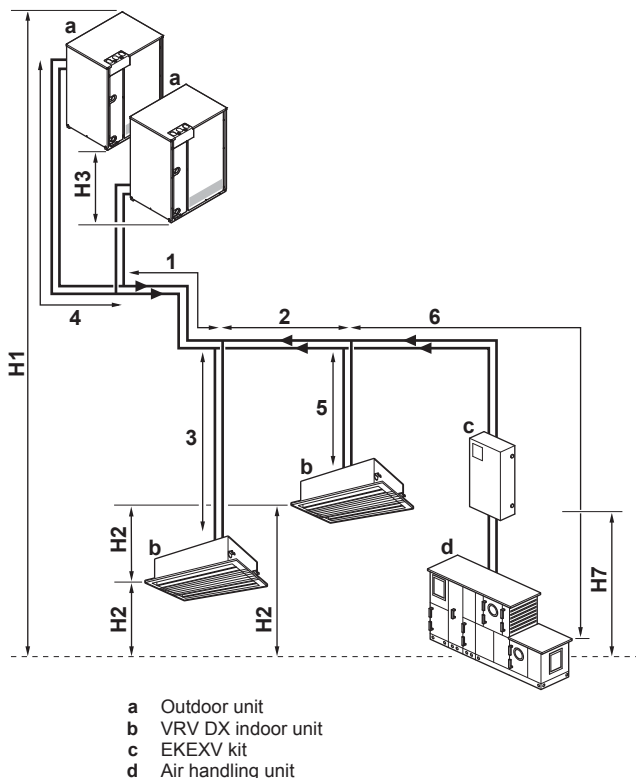

Pipe	Maximum length (actual/equivalent)
Longest pipe from the outdoor unit or the last multi-outdoor piping branch (1+2+6, 1+3, 1+2+5)	165 m/190 m <sup>(a)</sup>
Longest pipe after the first branch (3, 2+6, 2+5)	40 m/—
In case of a multi-outdoor setup: longest pipe from the outdoor unit to the last multi-outdoor piping branch (4)	10 m/13 m
Total pipe length (1+2+3+5+6)	300 m/—

- (a) If the equivalent piping length is more than 90 m, size up the main liquid piping according to "5.3.2 To select the piping size" on page 13.

##### Connection with VRV DX indoor units and Hydrobox units

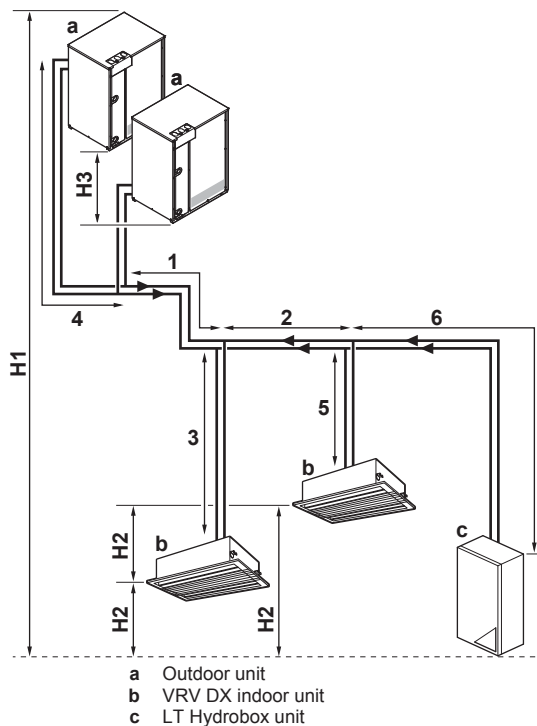

Pipe	Maximum length (actual/equivalent)
Longest pipe from the outdoor unit or the last multi-outdoor piping branch (1+2+6, 1+3, 1+2+5)	120 m/140 m
Longest pipe after the first branch (3, 2+6, 2+5)	40 m/—
In case of a multi-outdoor setup: longest pipe from the outdoor unit to the last multi-outdoor piping branch (4)	10 m/13 m
Total pipe length (1+2+3+5+6)	300 m/—



Connection with only VRV DX and RA DX indoor units

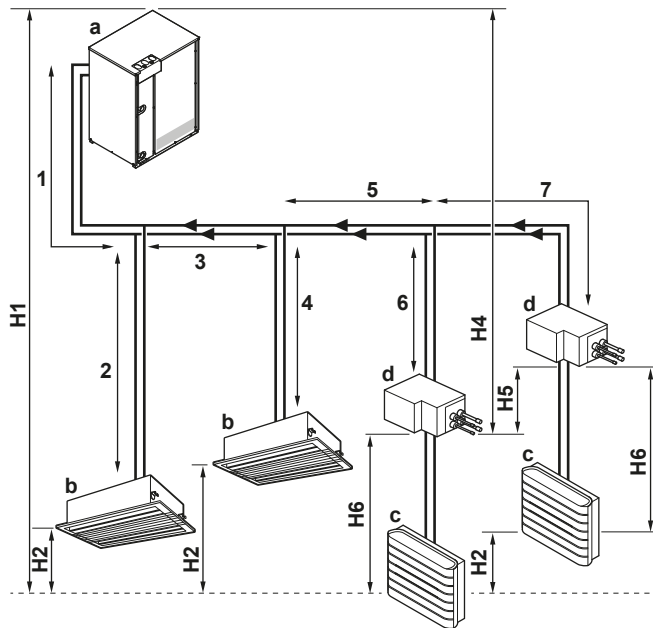

- a Outdoor unit
- b VRV DX indoor unit
- c RA DX indoor unit<sup>(1)</sup>
- d BP box

(1) This connection is only allowed on a single outdoor unit installation.

Pipe	Maximum length (actual/equivalent)
Longest pipe from the outdoor unit or the last multi-outdoor piping branch (1+2, 1+3+4, 1+3+5+6, 1+3+5+7)	100 m/120 m
Longest pipe after the first branch (3+4, 3+5+6, 3+5+7)	40 m/—
Total pipe length (1+2+3+4+5+6+7+8+9)	250 m/—

Between BP unit and indoor unit:

Indoor unit capacity index	Pipe length
<60	2~15 m
60	2~12 m
71	2~8 m

**Remark: Minimum allowable length** between the outdoor unit and first refrigerant branch kit must be larger than 5 m (e.g., a>5 m).

If the piping length between the first branch and BP unit or VRV DX indoor unit is larger than 20 m, it is necessary to increase the gas and liquid piping size between the first branch and BP unit or VRV DX indoor unit. If the piping diameter of the sized up piping exceeds the diameter of the piping before the first branch kit, then the latter also requires a liquid piping and gas piping size up.

In case of heat recovery system

Connection with VRV DX indoor units and air handling units

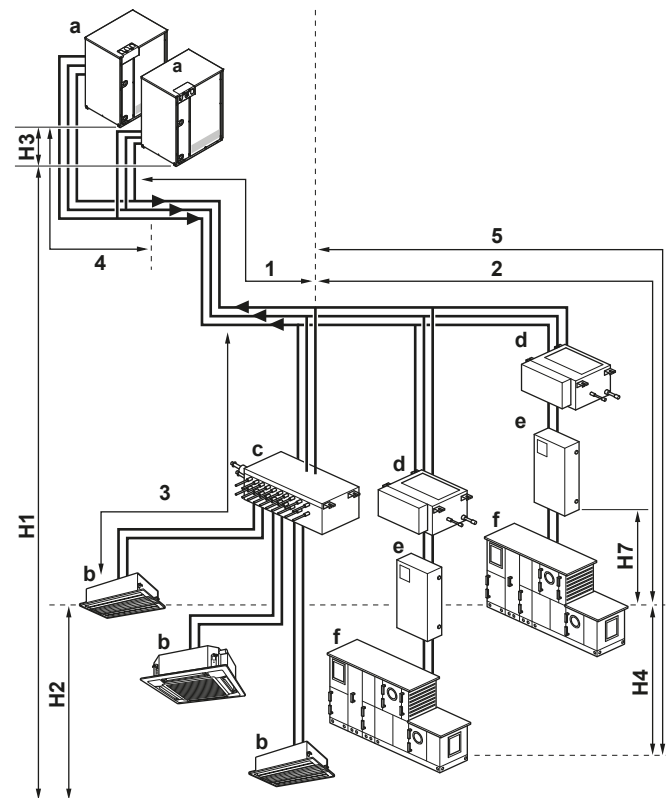

- a Outdoor unit
- b VRV DX indoor unit
- c Multi BS unit
- d BS unit
- e EKEXV kit
- f AHU

Pipe	Maximum length (actual/equivalent)
Longest pipe from the outdoor unit or the last multi-outdoor piping branch (1+2, 1+3, 1+5)	165 m/190 m <sup>(a)</sup>
Longest pipe after the first branch (2, 3, 5)	40 m/—
In case of a multi-outdoor setup: longest pipe from the outdoor unit to the last multi-outdoor piping branch (4)	10 m/13 m
Total pipe length	300 m/—

(a) If the equivalent piping length is more than 90 m, size up the main liquid piping according to "5.3.2 To select the piping size" on page 13.

## 5 Preparation

### Connection with VRV DX indoor units and Hydrobox units

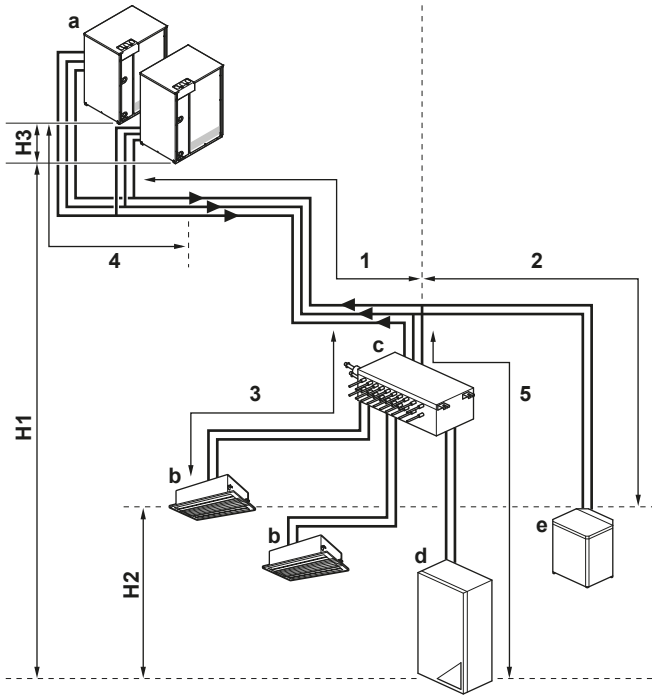

- a Outdoor unit
- b VRV DX indoor unit
- c Multi BS unit
- d LT Hydrobox unit
- e HT Hydrobox unit

Pipe	Maximum length (actual/equivalent)
Longest pipe from the outdoor unit or the last multi-outdoor piping branch (1+2, 1+3, 1+5)	120 m/140 m <sup>(a)</sup>
Longest pipe after the first branch (2, 3, 5)	40 m/—
In case of a multi-outdoor setup: longest pipe from the outdoor unit to the last multi-outdoor piping branch (4)	10 m/13 m
Total pipe length	300 m/—

- (a) If the equivalent piping length is more than 90 m, size up the main liquid piping according to "5.3.2 To select the piping size" on page 13.

### Connection with only VRV DX indoor units

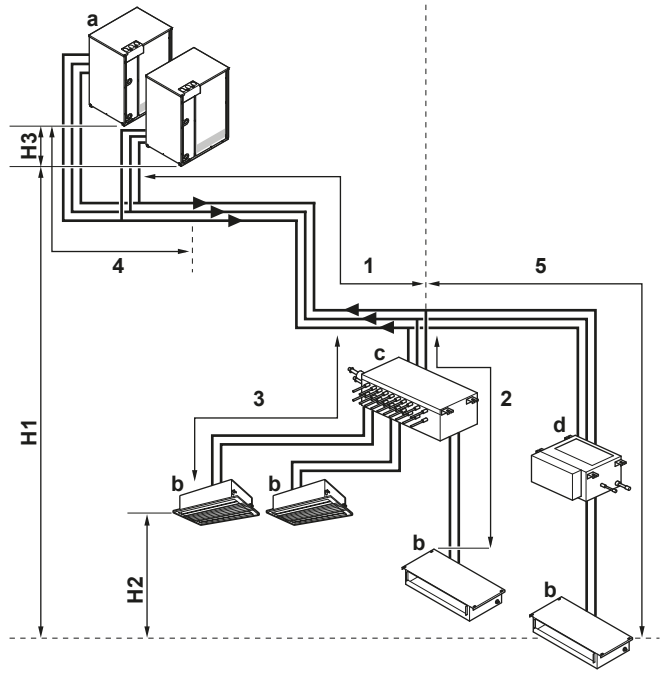

- a Outdoor unit
- b VRV DX indoor unit
- c Multi BS unit
- d Single BS unit

Pipe	Maximum length (actual/equivalent)
Longest pipe from the outdoor unit or the last multi-outdoor piping branch (1+2, 1+3, 1+5)	165 m/190 m <sup>(a)</sup>
Longest pipe after the first branch (2, 3, 5)	40 m/—
In case of a multi-outdoor setup: longest pipe from the outdoor unit to the last multi-outdoor piping branch (4)	10 m/13 m
Total pipe length	300 m/—

### 5.3.6 Multiple outdoor units: Possible layouts

- The piping between the outdoor units must be routed level or slightly upward to avoid the risk of oil retention into the piping.

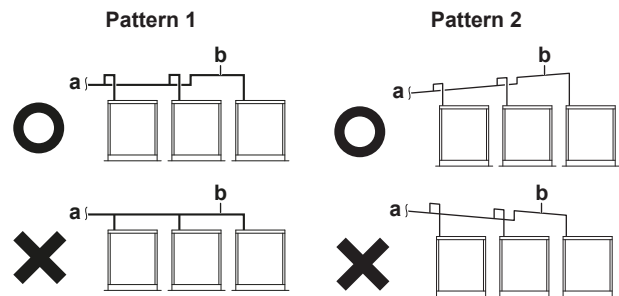

- a To indoor unit
- b Piping between outdoor units
- X Not allowed (oil remains in piping)
- O Allowed

- If the piping length between the outdoor unit connecting pipe kit or between the outdoor units exceeds 2 m, create a rise of 200 mm or more in the gas line within a length of 2 m from the kit.
- For the gas piping (both discharge and suction gas piping in case of the heat recovery system) after the branch, install a trap of 200 mm or more using the piping included in the piping kit for connecting the outdoor unit. Otherwise, the refrigerant may stay in the piping, causing damage to the outdoor unit.

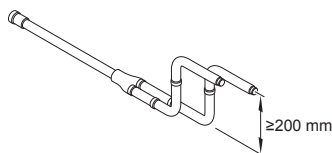

- a To indoor unit
- b Piping between outdoor units



### NOTICE

There are restrictions on the refrigerant pipe connection order between outdoor units during installation in case of a multiple outdoor unit system. Install according to following restrictions. The capacities of outdoor units A, B and C must fulfill the following restriction conditions:  $A \geq B \geq C$ .

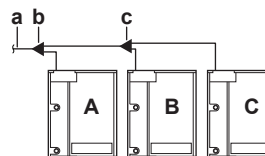

- a To indoor units
- b Outdoor unit multi connecting piping kit (first branch)
- c Outdoor unit multi connecting piping kit (second branch)

If	Then
$\leq 2$ m	
$> 2$ m	

## 5.4 Preparing water piping

### 5.4.1 Water quality requirements

Item <sup>(a)</sup>	Cooling water <sup>(b)</sup> and circulation system		Hot water system <sup>(c)</sup>		Tendency <sup>(d)</sup>	
	Circulation water	Make-up water	Circulation water	Make-up water	Corrosion	Scale
Standard items						
pH (25°C)	6.5~8.2	6.0~8.0	7.0~8.0		○	○
Electrical conductivity (mS/m) (25°C)	<80	<30	<30		○	○
Chloride ions (mg Cl <sup>-</sup> /l)	<200	<50	<50		○	
Sulfate ions (mg SO <sub>4</sub> <sup>2-</sup> /l)	<200	<50	<50		○	
Acid consumption (pH 4.8) (mg CaCO <sub>3</sub> /l)	<100	<50	<50			○
Total hardness (mg CaCO <sub>3</sub> /l)	<200	<70	<70			○
Calcium hardness (mg CaCO <sub>3</sub> /l)	<50		<50			○
Ionic-state silica (mg SiO <sub>2</sub> /l)	<50	<30	<30			○
Reference items						
Iron (mg Fe/l)	<1.0	<0.3	<1.0	<0.3	○	○
Copper (mg Cu/l)	<0.3	<0.1	<1.0	<0.1	○	
Sulfate ion (mg S <sup>2-</sup> /l)	—		—		○	
Ammonium ion (mg NH <sub>4</sub> <sup>+</sup> /l)	<1.0	<0.1	<0.3	<0.1	○	
Residual chlorine (mg Cl/l)	<0.3		<0.25	<0.3	○	
Free carbon dioxide (mg CO <sub>2</sub> /l)	<4.0		<0.4	<4.0	○	
Stability index	6.0~7.0	—	—		○	○

- (a) These items represent typical causes of corrosion and scale.
- (b) In a condenser water circuit that uses a closed cooling tower, the closed circuit circulating water and make-up water MUST meet the water quality standards for the hot water system, and passing water and make-up water MUST satisfy those for the circulation type cooling water system.
- (c) Corrosion has a tendency to occur when water temperature is high (40°C or higher), and if metals with no protective coating are directly exposed to water, it would be a good idea to take effective measures against corrosion such as adding a corrosion inhibitor or deaeration treatment.
- (d) The circle marks in the columns indicate a tendency for corrosion or scale to develop.



### NOTICE

- The supply water MUST be clean tap water, industrial water or clean underground water. Do NOT use purified or softened water.
- Do NOT use once-through water. It may cause corrosion.



### NOTICE

In case of plastic pipes, make sure they are fully oxygen diffusion tight according to DIN 4726. The diffusion of oxygen into the piping can lead to excessive corrosion.

- **Connecting piping – Legislation.** Make all piping connections in accordance with the applicable legislation and the instructions in the "Installation" chapter, respecting the water inlet and outlet.
- **Connecting piping – Force.** Do NOT use excessive force when connecting the piping. Deformation of the piping can cause malfunctioning of the unit.

### 5.4.2 Water circuit requirements



### INFORMATION

Also read the precautions and requirements in the "General safety precautions" chapter.

## 5 Preparation

- **Connecting piping – Tools.** Only use appropriate tooling to handle brass, which is a soft material. If NOT, pipes will get damaged.
- **Connecting piping – Stainless steel.** Only use stainless steel material to connect the water piping to the unit. If NOT, pipes will get corroded. Take preventive measures, for example by insulating the connection on the water pipe.
- **Connecting piping – Air, moisture, dust.** If air, moisture or dust gets into the circuit, problems may occur. To prevent this:
  - Only use clean pipes
  - Hold the pipe end downwards when removing burrs.
  - Cover the pipe end when inserting it through a wall, to prevent dust and/or particles entering the pipe.
  - Use a decent thread sealant to seal connections.
- **Piping work – Dripping.** The outdoor unit is intended for indoor installation. Carry out piping work in such a way that no water drips on the outdoor unit.
- **Outlets.** Do NOT connect the **drain** outlet to the **water** outlet.
- **Filter.** Install the filter in the water piping inlet within a distance of 1.5 m from the outdoor unit. If sand, waste or rust particles are mixed in the water circulation system, metal materials will become corroded.
- **Insulation.** Insulate up to the base of the heat exchanger.

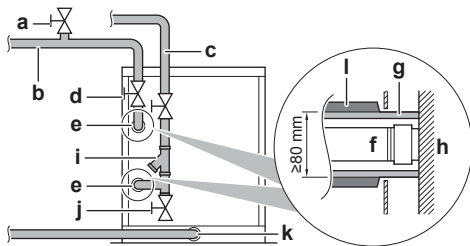

- a Air purge (field supply)
- b Water outlet
- c Water inlet
- d Shut-off valve (field supply)
- e Water connection
- f Water piping (field supply)
- g Insulation (field supply)
- h Heat exchanger
- i Filter (accessory)
- j Drain valve (field supply)
- k Drain connection
- l Insulation cover

- **Water pump.** After filling the water piping, run the water pump (field supply) to flush the water piping. After flushing, clean the filter.
- **Freeze.** Protect against freezing.
- **Water pipes.** ALWAYS comply with local and national regulations.
- **Water piping – Tightening torque.** Securely tighten the water piping with a tightening torque of  $\leq 300 \text{ N}\cdot\text{m}$ . Overtightening results in damage to the unit.
- **Field supply components – Water.** Only use materials that are compatible with water used in the system and with the materials used in the outdoor unit.
- **Field supply components – Water pressure and temperature.** Check that all components in the field piping can withstand the water pressure and water temperature.
- **Water pressure.** The maximum water pressure is 37 bar. Provide adequate safeguards in the water circuit to ensure that the maximum pressure is NOT exceeded.
- **Drainage – Low points.** Provide drain taps at all low points of the system in order to allow complete drainage of the water circuit.
- **Drainage – Clogging.** Make sure that the water runs smoothly without any clogging by dirt.

- **Drainage – Lateral length.** Lateral length of drainage should be as short as possible ( $\leq 400 \text{ mm}$ ) and installed in a downward direction. The diameter of the drain pipe must be the same as the diameter of the pipe on the outdoor unit.
- **Non-brass metallic piping.** When using non-brass metallic piping, insulate the brass and non-brass properly so that they do NOT make contact with each other. This to prevent galvanic corrosion.

### 5.4.3 Handling the brazed plate heat exchanger



#### INFORMATION

A brazed plate heat exchanger is used. Because of a different structure from a conventional heat exchanger, it MUST be handled in a different manner.

- Install a water filter at the water inlet in order to prevent foreign materials such as dust, sand,... from entering the plate heat exchanger.
- Scale can stick to the plate heat exchanger depending on water quality. To remove scale, cleaning is necessary at regular intervals using chemicals. Install a shut-off valve at the end in the water piping. Install a piping connection port on the piping between this shut-off valve and the outdoor unit for cleaning by chemicals.
- For cleaning and water draining of the outdoor unit (long period of non-use or during non-use in winter), install an air purge plug (for joint use with cleaning port) (field supply) and a water draining plug at the inlet/outlet ports of the water piping. Additionally, install an automatic air purge valve (field supply) at the top of rising piping or at the top of a portion where air tends to stay.
- Install an additional cleanable filter (field supply) in front of the pump inlet.
- Carry out complete cooling/thermal insulation of the water piping and the outdoor unit drain piping. If insulation has not been carried out, the unit may sustain damage during severe winters due to freezing, in addition to thermal loss.
- When you stop the unit during night or winter, take measures to prevent water circuits from natural freezing in areas where the ambient temperature drops below  $0^\circ\text{C}$  (by water drain off, keeping the circulation pump running, warming up by a heater,...). Freezing of water circuits may result in damage to the plate heat exchanger. Therefore, take appropriate measures depending on the circumstances.

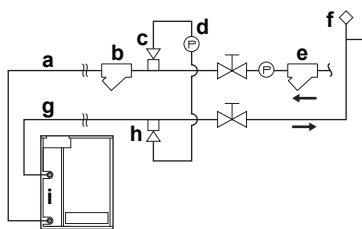

- a Water inlet piping
- b Filter (accessory)
- c Air purge plug (for joint use with cleaning port) (field supply)
- d Cleaning device
- e Filter for pump (field supply)
- f Automatic air purge valve (field supply)
- g Water outlet piping
- h Joint use with water draining plug
- i Plate heat exchanger

### 5.4.4 About the water flow rate

The RWEYQ\*T9Y1B models are equipped with the logic to operate with a variable water flow rate function.

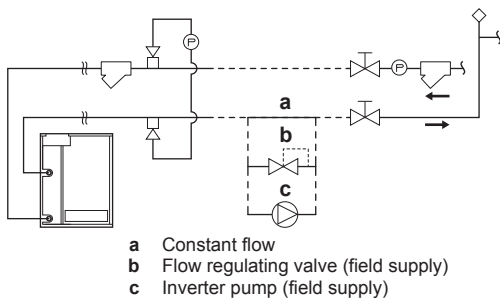

A system can either be configured as a constant flow system (a), a variable flow system with valve (b) or a variable flow system with a pump (c).

- Constant flow system (a): the variable water flow rate function is not used.
- A pressure independent flow regulating valve (b): the valve controls the flow rate of a centralized inverter pump through the unit.
- Inverter pump (c): the pump directly controls the water flow rate through the unit.

To activate the variable flow system, change field setting [2-24] to the applicable value. See "7.2 Making field settings" on page 36.

### NOTICE

Make sure that all field supplied equipment for variable flow rate can be switched off together with the outdoor unit. This is required when cleaning the plate heat exchanger.

### NOTICE

Make sure that all field supplied equipment for variable flow rate meet the minimum hydronic and electric specifications. Failure to do so can result in inefficient operation or even breakdown of the system.

Size the valve (b) or pump (c) in accordance with the maximum required flow rate A, calculated by the installer of the hydronic system (with respect to the operation range of the outdoor unit). The typical operation range of the flow rate of the valve/pump is 50% (B) to 100% (A).

The valve/pump input signal is based on a variable 2~10 V DC control output signal coming from the outdoor unit. The valve or pump should have a linear control characteristic between unit output signal and flow rate according to the example graph below.

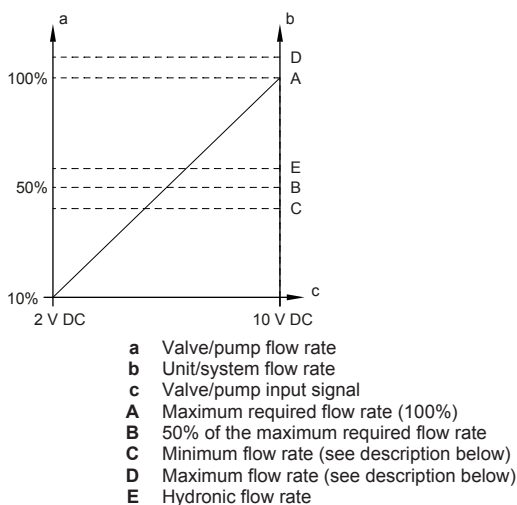

Follow the design criteria below to select the correct valve for the system. The valve system maximum required flow rate A is a property of the supplied valve and the 50% flow rate B is directly related to the maximum flow rate of the system.

### INFORMATION

Some third party valves/pumps have a maximum flow rate defined by the hardware of the system, but a different maximum flow rate can be set to correspond with the maximum input voltage (10 V DC). The installer should ask information to the valve/pump supplier before making the selection.

#### Design criteria

##### 1 Minimum flow rate C:

Model	C
RWEYQ8~12	50 l/min
RWEYQ14	75 l/min

##### 2 Maximum flow rate D:

Model	D
RWEYQ8~12	120 l/min
RWEYQ14	190 l/min

##### 3 Hydronic flow rate E:

The value E is the design flow rate calculated by the hydronic engineer when designing the building system.

Correct valve selection is done when following conditions are met:

#### (B≥C) AND (E≤A≤D)

For further selection requirements, refer to "5.5 Preparing electrical wiring" on page 21.

Check the minimum flow rate of the system during commissioning to ensure good operation.

During the initialization process of the outdoor unit, the output signal will trigger a flow rate of B (50%). The installer should make sure that a flow rate can be checked in the individual hydronic system of each unit. If this value is not matching the required flow, the installer should troubleshoot the hydronic system to solve the problem and ensure the correct flow rate.

To set a different minimum flow rate for the system, change field setting [2-25] to the applicable value. See "7.2 Making field settings" on page 36.

## 5.5 Preparing electrical wiring

### 5.5.1 About electrical compliance

This equipment complies with:

- EN/IEC 61000-3-12 provided that the short-circuit power  $S_{sc}$  is greater than or equal to the minimum  $S_{sc}$  value at the interface point between the user's supply and the public system.
- EN/IEC 61000-3-12 = European/International Technical Standard setting the limits for harmonic currents produced by equipment connected to public low-voltage systems with input current >16 A and ≤75 A per phase.
- It is the responsibility of the installer or user of the equipment to ensure, by consultation with the distribution network operator if necessary, that the equipment is connected only to a supply with a short-circuit power  $S_{sc}$  greater than or equal to the minimum  $S_{sc}$  value.

Model	Minimum $S_{sc}$ value
RWEYQ8~14T9	1780 kVA

Because of the free multi combination, it is the responsibility of the installer to calculate the minimum  $S_{sc}$  value for the multi combination. The value is calculated by adding up the values of the corresponding units used in the multi combination.  $RWEYQ28T9=2 \times RWEYQ10T9+RWEYQ8T9$ .

## 6 Installation

### 5.5.2 Safety device requirements

The power supply must be protected with the required safety devices, i.e. a main switch, a slow blow fuse on each phase and an earth leakage protector in accordance with the applicable legislation.

#### For standard combinations

Selection and sizing of the wiring should be done in accordance with the applicable legislation based on the information mentioned in the table below.

Model	Minimum circuit ampacity	Recommended fuses
RWEYQ8T9	15.5 A	20 A
RWEYQ10T9	16.4 A	20 A
RWEYQ12T9	19.4 A	25 A
RWEYQ14T9	22.3 A	25 A
RWEYQ16T9	31.0 A	32 A
RWEYQ18T9	31.9 A	32 A
RWEYQ20T9	32.7 A	35 A
RWEYQ22T9	35.8 A	40 A
RWEYQ24T9	38.9 A	40 A
RWEYQ26T9	41.7 A	50 A
RWEYQ28T9	44.6 A	50 A
RWEYQ30T9	49.1 A	50 A
RWEYQ32T9	52.2 A	63 A
RWEYQ34T9	55.3 A	63 A
RWEYQ36T9	58.3 A	63 A
RWEYQ38T9	61.2 A	63 A
RWEYQ40T9	64.0 A	80 A
RWEYQ42T9	66.9 A	80 A

For all models:

- Phase and frequency: 3N~ 50 Hz
- Voltage: 380~415 V
- Transmission line section: 0.75~1.25 mm<sup>2</sup>, maximum length is 1000 m. If the total transmission wiring exceeds these limits, it may result in communication error.

#### For free combinations

Calculate the recommended fuse capacity.

Formula	Calculate, by adding the minimum circuit amps of each used unit (according to the table above), multiply the result by 1.1 and select the next higher recommended fuse capacity.
Example	<p>Combining the RWEYQ30T9 by using the RWEYQ8T9, RWEYQ10T9, and RWEYQ12T9.</p> <ul style="list-style-type: none"> <li>Minimum circuit ampacity of the RWEYQ8T9=15.5 A</li> <li>Minimum circuit ampacity of the RWEYQ10T9=16.4 A</li> <li>Minimum circuit ampacity of the RWEYQ12T9=19.4 A</li> </ul> <p>Accordingly, the minimum circuit ampacity of the RWEYQ30T9=15.5+16.4+19.4=51.3 A</p> <p>Multiply the above result by 1.1 ⇒ (51.3 A×1.1)=56.43 A ⇒ the recommended fuse capacity would be <b>63 A</b>.</p>



#### NOTICE

When using residual current operated circuit breakers, be sure to use a high-speed type 300 mA rated residual operating current.

## 6 Installation

### 6.1 Overview: Installation

This chapter describes what you have to do and know on-site to install the system.

#### Typical workflow

Installation typically consists of the following stages:

- 1 Mounting the outdoor unit
- 2 Connecting the refrigerant piping
- 3 Checking the refrigerant piping
- 4 Insulating the refrigerant piping
- 5 Charging refrigerant
- 6 Connecting the water piping
- 7 Connecting the electrical wiring

### 6.2 Opening the units

#### 6.2.1 To open the outdoor unit



**DANGER: RISK OF ELECTROCUTION**



**DANGER: RISK OF BURNING**

To gain access to the unit, front plates need to be opened as follows:

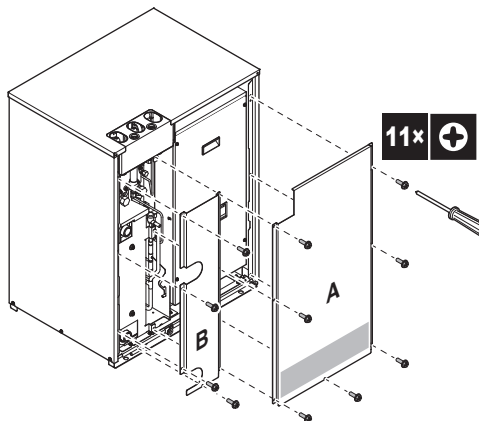

Once the front plate A is open, the electrical component box can be accessed. See "6.2.2 To open the electrical component box of the outdoor unit" on page 23.

For service purposes, the pushbuttons on the main PCB need to be accessed. To access these pushbuttons, the electrical component box cover does not need to be opened. See "7.2.3 To access the field setting components" on page 36.

To install the water piping and field wiring, front plate B has to be removed.

### 6.2.2 To open the electrical component box of the outdoor unit



#### NOTICE

Do NOT apply excessive force when opening the electronic component box cover. Excessive force can deform the cover, resulting in entering of water to cause equipment failure.

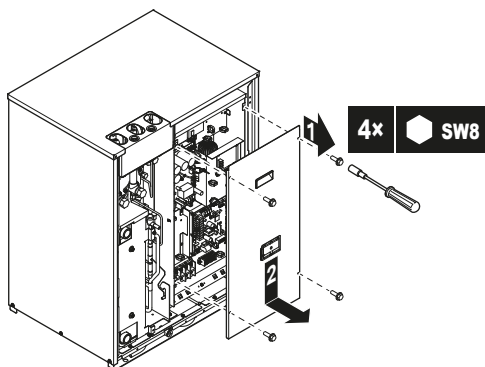

## 6.3 Mounting the outdoor unit

### 6.3.1 To provide the installation structure

Make sure the unit is installed level on a sufficiently strong base to prevent vibration and noise.

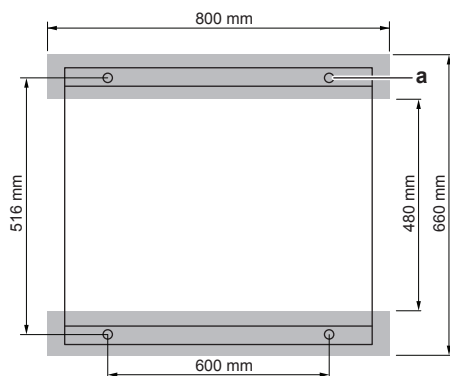

- Fasten the unit in place using four foundation bolts M12. It is best to screw in the foundation bolts until their length remains 20 mm above the foundation surface.

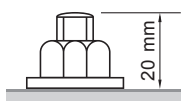

## 6.4 Connecting the refrigerant piping

### 6.4.1 Precautions when connecting the refrigerant piping



#### NOTICE

Make sure refrigerant piping installation complies with applicable legislation. In Europe, EN378 is the applicable standard.



#### NOTICE

Make sure the field piping and connections are NOT subjected to stress.



#### WARNING

During tests, NEVER pressurize the product with a pressure higher than the maximum allowable pressure (as indicated on the nameplate of the unit).



#### WARNING

Take sufficient precautions in case of refrigerant leakage. If refrigerant gas leaks, ventilate the area immediately. Possible risks:

- Excessive refrigerant concentrations in a closed room can lead to oxygen deficiency.
- Toxic gas may be produced if refrigerant gas comes into contact with fire.



#### WARNING

ALWAYS recover the refrigerant. Do NOT release them directly into the environment. Use a vacuum pump to evacuate the installation.



#### NOTICE

After all the piping has been connected, make sure there is no gas leak. Use nitrogen to perform a gas leak detection.

### 6.4.2 About connecting the refrigerant piping

Before connecting the refrigerant piping, make sure the outdoor and indoor units are mounted.

Connecting the refrigerant piping involves:

- Routing and connecting the refrigerant piping to the outdoor unit
- Protecting the outdoor unit against contamination
- Connecting the refrigerant piping to the indoor units (see the installation manual of the indoor units)
- Connecting the multi-connection piping kit
- Connecting the refrigerant branching kit
- Keeping in mind the guidelines for:
  - Brazing
  - Using the stop valves
  - Removing the pinched pipes

### 6.4.3 To route the refrigerant piping

Installation of refrigerant piping is possible as top connection (standard) or front connection.

#### In case of top connection

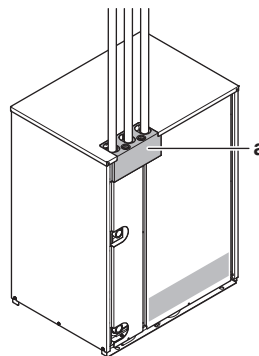

#### In case of front connection

Remove and change the position of the pipe service plate (a) as shown in figure below.

## 6 Installation

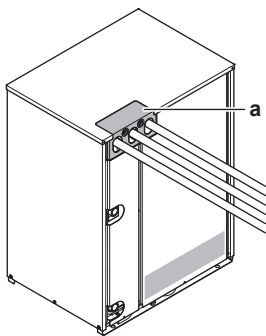

### 6.4.4 To connect the refrigerant piping to the outdoor unit



#### INFORMATION

All local inter unit piping are field supplied except the accessory pipes.



#### NOTICE

Precautions when connecting field piping. Add brazing material as shown in the figure.

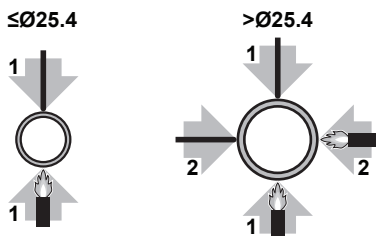

#### NOTICE

- Be sure to use the supplied accessory pipes when carrying out piping work in the field.
- Be sure that the field installed piping does not touch other pipes, the bottom panel or side panel. Especially for the bottom and side connection, be sure to protect the piping with suitable insulation, to prevent it from coming into contact with the casing.

Connect the stop valves to the field piping using the accessory pipes supplied with the unit.

The connections to the branch kits are the responsibility of the installer (field piping).

### 6.4.5 To connect the multi connection piping kit



#### NOTICE

Improper installation may lead to malfunction of the outdoor unit.

- Install the joints horizontally, so that the caution label (a) attached to the joint comes to the top.
  - Do not tilt the joint more than 7.5° (see view A).
  - Do not install the joint vertically (see view B).

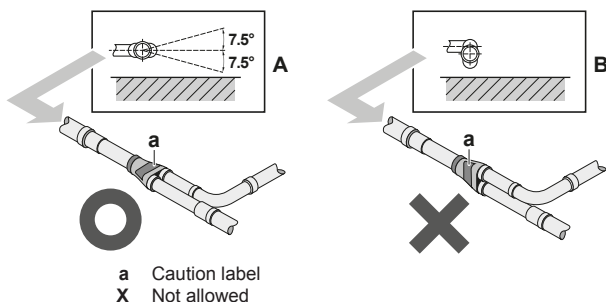

a Caution label  
X Not allowed

O Allowed

- Make sure that the total length of the piping connected to the joint is absolute straight for more than 500 mm. Only if a straight field piping of more than 120 mm is connected, more than 500 mm of straight section can be ensured.

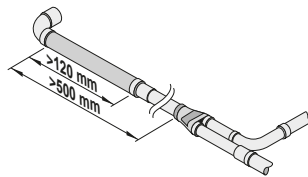

### 6.4.6 To connect the refrigerant branching kit

For installation of the refrigerant branching kit, refer to the installation manual delivered with the kit.

- Mount the refnet joint so that it branches either horizontally or vertically.
- Mount the refnet header so that it branches horizontally.

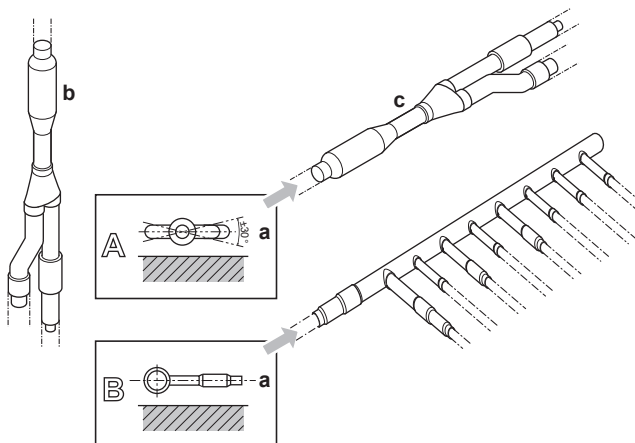

a Horizontal surface  
b Refnet joint mounted vertically  
c Refnet joint mounted horizontally

### 6.4.7 To protect against contamination

Protect the piping as described in the following table to prevent dirt, liquid or dust from entering the piping.

Unit	Installation period	Protection method
Outdoor unit	>1 month	Pinch the pipe
	<1 month	Pinch or tape the pipe
Indoor unit	Regardless of the period	

Seal the piping and wiring intake holes using sealing material (field supply), otherwise the capacity of the unit will drop and small animals may enter the machine.

If the gaps are not properly sealed, sound level will increase and sweat problems can occur.



### 6.4.8 To braise the pipe end



**NOTICE**

Precautions when connecting field piping. Add brazing material as shown in the figure.

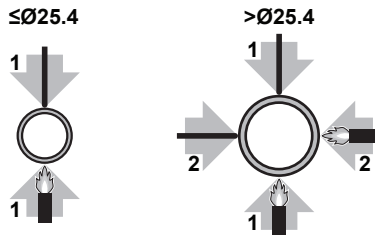

- When brazing, blow through with nitrogen to prevent creation of large quantities of oxidised film on the inside of the piping. This film adversely affects valves and compressors in the refrigerating system and prevents proper operation.
- Set the nitrogen pressure to 20 kPa (0.2 bar) (just enough so it can be felt on the skin) with a pressure-reducing valve.

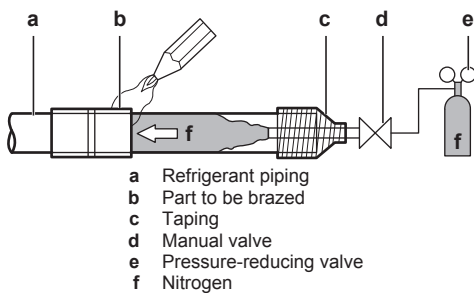

- a Refrigerant piping
- b Part to be brazed
- c Taping
- d Manual valve
- e Pressure-reducing valve
- f Nitrogen

- Do NOT use anti-oxidants when brazing pipe joints. Residue can clog pipes and break equipment.
- Do NOT use flux when brazing copper-to-copper refrigerant piping. Use phosphor copper brazing filler alloy (BCuP), which does not require flux. Flux has an extremely harmful influence on refrigerant piping systems. For instance, if chlorine based flux is used, it will cause pipe corrosion or, in particular, if the flux contains fluorine, it will deteriorate the refrigerant oil.

### 6.4.9 Using the stop valve and service port

#### To handle the stop valve

- Make sure to keep the appropriate stop valves open during operation. In case of heat pump system, the gas suction stop valve remains in the closed position.
- The stop valves are factory closed.
- The figure below shows the name of each part required in handling the stop valve.

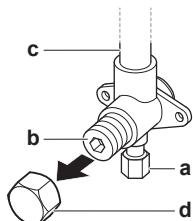

- a Service port and service port cover
- b Stop valve
- c Field piping connection
- d Stop valve cover

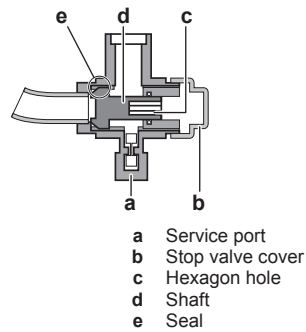

- a Service port
- b Stop valve cover
- c Hexagon hole
- d Shaft
- e Seal

#### To open the stop valve

- Remove the stop valve cover.
- Insert a hexagon wrench into the stop valve and turn the stop valve counterclockwise.

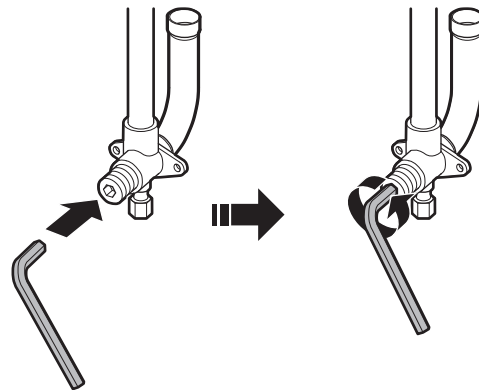

- When the stop valve cannot be turned any further, stop turning.
- Install the stop valve cover.

**Result:** The valve is now open.

To fully open the Ø19.1 mm~Ø25.4 mm stop valve, turn the hexagonal wrench until a torque between 27 and 33 N·m is achieved.

Inadequate torque may cause leakage of refrigerant and breakage of the stop valve cap.

#### To close the stop valve

- Remove the stop valve cover.
- Insert a hexagon wrench into the stop valve and turn the stop valve clockwise.

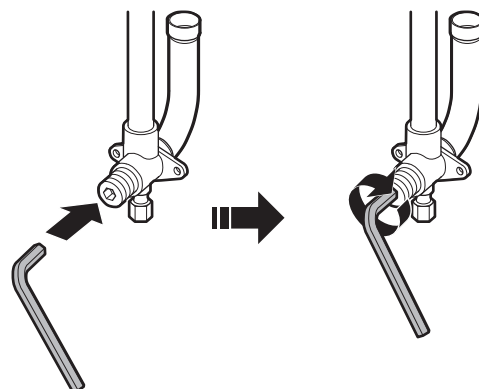

- When the stop valve cannot be turned any further, stop turning.
- Install the stop valve cover.

**Result:** The valve is now closed.

## 6 Installation

### To handle the stop valve cover

- The stop valve cover is sealed where indicated by the arrow. Do NOT damage it.
- After handling the stop valve, tighten the stop valve cover securely, and check for refrigerant leaks. For the tightening torque, refer to the table below.

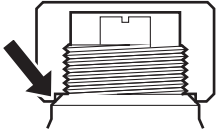

### To handle the service port

- Always use a charge hose equipped with a valve depressor pin, since the service port is a Schrader type valve.
- After handling the service port, make sure to tighten the service port cover securely. For the tightening torque, refer to the table below.
- Check for refrigerant leaks after tightening the service port cover.

### Tightening torques

Stop valve size (mm)	Tightening torque N·m (turn clockwise to close)			
	Shaft			Service port
Valve body	Hexagonal wrench	Cap (valve lid)		
Ø9.5	5.4~6.6	4 mm	13.5~16.5	11.5~13.9
Ø12.7	8.1~9.9		18.0~22.0	
Ø15.9	13.5~16.5	6 mm	23.0~27.0	
Ø19.1	27.0~33.0	8 mm	22.5~27.5	
Ø25.4				

#### 6.4.10 To remove the pinched pipes

##### NOTICE

In case of heat pump system, do NOT remove the pinched pipe of the suction gas stop valve.

##### WARNING

Any gas or oil remaining inside the stop valve may blow off the pinched piping.

Failure to observe the instructions in procedure below properly may result in property damage or personal injury, which may be serious depending on the circumstances.

Use the following procedure to remove the pinched piping:

- Remove the valve cover and make sure that the stop valves are fully closed.

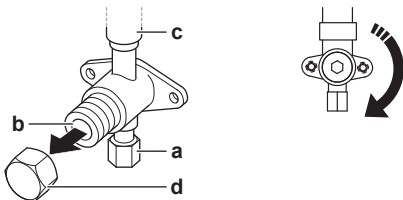

- a Service port and service port cover
- b Stop valve
- c Field piping connection
- d Stop valve cover

- Connect the vacuuming/recovery unit through a manifold to the service port of all stop valves.

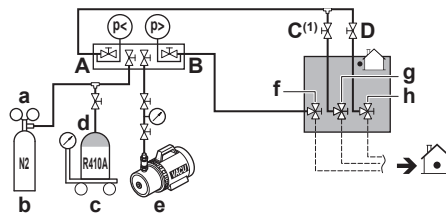

- a Pressure reducing valve
- b Nitrogen
- c Weighing scales
- d Refrigerant R410A tank (siphon system)
- e Vacuum pump
- f Liquid line stop valve
- g Gas line stop valve
- h High pressure/low pressure gas line stop valve
- A Valve A
- B Valve B
- C Valve C<sup>(1)</sup>
- D Valve D

(1) Only for heat recovery system.

##### NOTICE

Do not connect the vacuum pump to the suction gas stop valve if the unit is intended to run as a heat pump system. This will increase the risk of unit failure.

- Recover gas and oil from the pinched piping by using a recovery unit.

##### CAUTION

Do not vent gases into the atmosphere.

- When all gas and oil is recovered from the pinched piping, disconnect the charge hose and close the service ports
- Cut off the upper part of the following pipes with an appropriate tool (e.g. a pipe cutter):

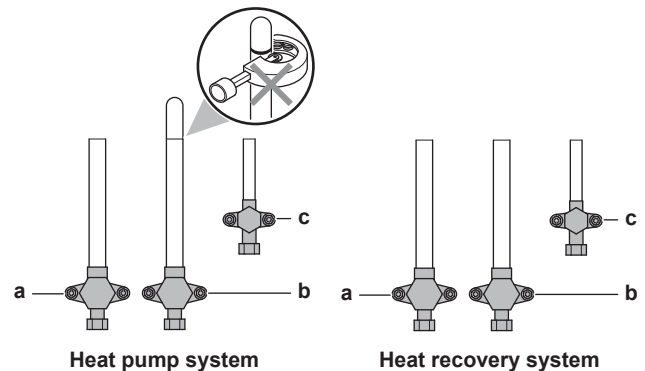

- a High pressure/low pressure gas stop valve
- b Suction gas stop valve (ONLY use in case of heat recovery system)
- c Liquid stop valve

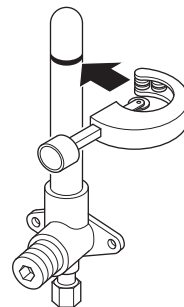

**WARNING**



Never remove the pinched piping by brazing.  
Any gas or oil remaining inside the stop valve may blow off the pinched piping.

- 6 Make sure that no particles remain in the pipe. Blow out any particles with compressed air.
- 7 Wait until all oil is dripped out before continuing with the connection of the field piping in case the recovery was not complete.

## 6.5 Checking the refrigerant piping

### 6.5.1 About checking the refrigerant piping

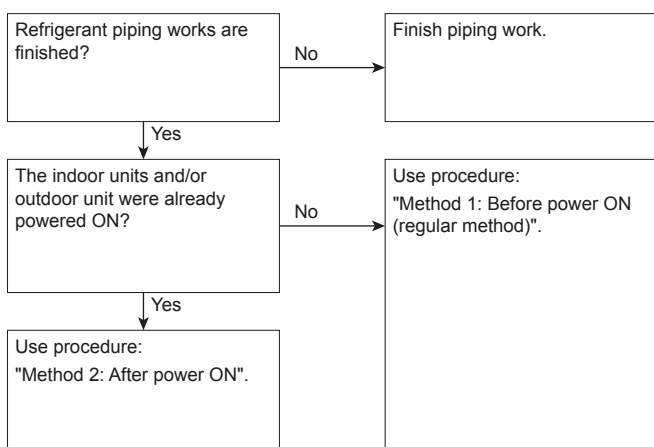

It is very important that all refrigerant piping work is done before the units (outdoor or indoor) are powered on.

When the units are powered on, the expansion valves will initialise. This means that they will close. Leak test and vacuum drying of field piping and indoor units is impossible when this happens.

Therefore, there will be explained 2 methods for initial installation, leak test and vacuum drying.

#### Method 1: Before power ON

If the system has not yet been powered on, no special action is required to perform the leak test and the vacuum drying.

#### Method 2: After power ON

If the system has already been powered on, activate setting [2-21] (refer to "7.2.4 To access mode 1 or 2" on page 36). This setting will open field expansion valves to guarantee a R410A piping pathway and make it possible to perform the leak test and the vacuum drying.



#### NOTICE

Make sure that all indoor units connected to the outdoor unit are powered on.



#### NOTICE

Wait until the outdoor unit has finished the initialisation to apply setting [2-21].

#### Leak test and vacuum drying

Checking the refrigerant piping involves:

- Checking for any leakages in the refrigerant piping.

- Performing vacuum drying to remove all moisture, air or nitrogen in the refrigerant piping.

If there is a possibility of moisture being present in the refrigerant piping (for example, water may have entered the piping), first carry out the vacuum drying procedure below until all moisture has been removed.

All piping inside the unit has been factory tested for leaks.

Only field installed refrigerant piping needs to be checked. Therefore, make sure that all the outdoor unit stop valves are firmly closed before performing leak test or vacuum drying.



#### NOTICE

Make sure that all (field supplied) field piping valves are OPEN (not outdoor unit stop valves!) before you start leak test and vacuuming.

For more information on the state of the valves, refer to "6.5.3 Checking refrigerant piping: Setup" on page 27.

### 6.5.2 Checking refrigerant piping: General guidelines

Connect the vacuum pump through a manifold to the service port of all stop valves to increase efficiency (refer to "6.5.3 Checking refrigerant piping: Setup" on page 27).



#### NOTICE

Use a 2-stage vacuum pump with a non-return valve or a solenoid valve that can evacuate to a gauge pressure of -100.7 kPa (-1.007 bar) (5 Torr absolute).



#### NOTICE

Make sure the pump oil does not flow oppositely into the system while the pump is not working.



#### NOTICE

Do not purge the air with refrigerants. Use a vacuum pump to evacuate the installation.

### 6.5.3 Checking refrigerant piping: Setup

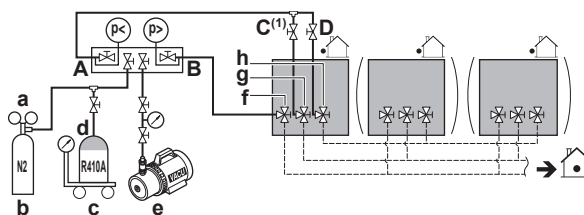

- a Pressure reducing valve
- b Nitrogen
- c Weighing scales
- d Refrigerant R410A tank (siphon system)
- e Vacuum pump
- f Liquid line stop valve
- g Gas line stop valve
- h High pressure/low pressure gas line stop valve
- A Valve A
- B Valve B
- C Valve C<sup>(1)</sup>
- D Valve D

(1) Only for heat recovery system.



#### NOTICE

Do not connect the vacuum pump to the suction gas stop valve if the unit is intended to run as a heat pump system. This will increase the risk of unit failure.

Valve	State of valve
Valve A	Open
Valve B	Open

## 6 Installation

Valve	State of valve
Valve C	Open
Valve D	Open
Liquid line stop valve	Close
Gas line stop valve	Close
High pressure/low pressure gas line stop valve	Close

### NOTICE

The connections to the indoor units and all indoor units should also be leak and vacuum tested. Keep any possible (field supplied) field piping valves open as well.

Refer to the indoor unit installation manual for more details. Leak test and vacuum drying should be done before the power supply is set to the unit. If not, see also the flow chart earlier described in this chapter (see ["6.5.1 About checking the refrigerant piping" on page 27](#)).

### 6.5.4 To perform a leak test

The leak test must satisfy the specifications of EN378-2.

#### To check for leaks: Vacuum leak test

- 1 Evacuate the system from the liquid and gas piping to  $-100.7$  kPa ( $-1.007$  bar) (5 Torr absolute) for more than 2 hours.
- 2 Once reached, turn off the vacuum pump and check that the pressure does not rise for at least 1 minute.
- 3 Should the pressure rise, the system may either contain moisture (see vacuum drying below) or have leaks.

#### To check for leaks: Pressure leak test

- 1 Break the vacuum by pressurising with nitrogen gas to a minimum gauge pressure of 0.2 MPa (2 bar). Never set the gauge pressure higher than the maximum operation pressure of the unit, i.e. 4.0 MPa (40 bar).
- 2 Test for leaks by applying a bubble test solution to all piping connections.
- 3 Discharge all nitrogen gas.

### NOTICE

Make sure to use a recommended bubble test solution from your wholesaler. Do not use soap water, which may cause cracking of flare nuts (soap water may contain salt, which absorbs moisture that will freeze when the piping gets cold), and/or lead to corrosion of flared joints (soap water may contain ammonia which causes a corrosive effect between the brass flare nut and the copper flare).

### 6.5.5 To perform vacuum drying

### NOTICE

The connections to the indoor units and all indoor units should also be leak and vacuum tested. Keep, if existing, all (field supplied) field valves to the indoor units open as well.

Leak test and vacuum drying should be done before the power supply is set to the unit. If not, see ["6.5.1 About checking the refrigerant piping" on page 27](#) for more information.

To remove all moisture from the system, proceed as follows:

- 1 Evacuate the system for at least 2 hours to a target vacuum of  $-100.7$  kPa ( $-1.007$  bar) (5 Torr absolute).

- 2 Check that, with the vacuum pump turned off, the target vacuum is maintained for at least 1 hour.
- 3 Should you fail to reach the target vacuum within 2 hours or maintain the vacuum for 1 hour, the system may contain too much moisture. In that case, break the vacuum by pressurising with nitrogen gas to a gauge pressure of 0.05 MPa (0.5 bar) and repeat steps 1 to 3 until all moisture has been removed.
- 4 Depending on whether you want to immediately charge refrigerant through the refrigerant charge port or first pre-charge a portion of refrigerant through the liquid line, either open the outdoor unit stop valves, or keep them closed. See ["6.6.2 About charging refrigerant" on page 29](#) for more information.

### INFORMATION

After opening the stop valve, it is possible that the pressure in the refrigerant piping does NOT increase. This might be caused by e.g. the closed state of the expansion valve in the outdoor unit circuit, but does NOT present any problem for correct operation of the unit.

## 6.6 Charging refrigerant

### 6.6.1 Precautions when charging refrigerant

#### WARNING

- Only use R410A as refrigerant. Other substances may cause explosions and accidents.
- R410A contains fluorinated greenhouse gases. Its global warming potential (GWP) value is 2087.5. Do NOT vent these gases into the atmosphere.
- When charging refrigerant, always use protective gloves and safety glasses.

### NOTICE

If the power of some units is turned off, the charging procedure cannot be finished properly.

### NOTICE

In case of a multiple outdoor system, turn on the power of all outdoor units.

### NOTICE

Be sure to turn on the power 6 hours before operation in order to have power running to the crankcase heater and to protect the compressor.

### NOTICE

If operation is performed within 12 minutes after the indoor and outdoor units are turned on, the compressor will not operate before the communication is established in a correct way between outdoor unit(s) and indoor units.

### NOTICE

Before starting charging procedures, check if the 7-segment display indication of the outdoor unit A1P PCB is as normal (see ["7.2.4 To access mode 1 or 2" on page 36](#)). If a malfunction code is present, see ["10.2 Solving problems based on error codes" on page 43](#).

### NOTICE

Close the front panel before any refrigerant charge operation is executed. Without the front panel attached the unit cannot judge correctly whether it is operating properly or not.

### 6.6.2 About charging refrigerant

The outdoor unit is factory charged with refrigerant, but depending on the field piping you have to charge additional refrigerant.

Make sure the outdoor unit's external refrigerant piping is checked (leak test, vacuum drying).

Charging additional refrigerant typically consists of the following stages:

- 1 Determining how much you have to charge additionally.
- 2 Charging additional refrigerant (pre-charging and/or charging).
- 3 Filling in the fluorinated greenhouse gases label, and fixing it to the inside of the outdoor unit.

### 6.6.3 To determine the additional refrigerant amount



#### INFORMATION

For final charge adjustment in the test laboratory, please contact your local dealer.



#### NOTICE

The refrigerant charge of the system must be less than 100 kg. This means that in case the calculated total refrigerant charge is equal to or more than 95 kg you must divide your multiple outdoor system into smaller independent systems, each containing less than 95 kg refrigerant charge. For factory charge, refer to the unit name plate.

#### In case of heat pump system

##### Formula:

$$R = [(X_1 \times \text{Ø}22.2) \times 0.37 + (X_2 \times \text{Ø}19.1) \times 0.26 + (X_3 \times \text{Ø}15.9) \times 0.18 + (X_4 \times \text{Ø}12.7) \times 0.12 + (X_5 \times \text{Ø}9.5) \times 0.059 + (X_6 \times \text{Ø}6.4) \times 0.022] + A$$

**R** Additional refrigerant to be charged [in kg and rounded off to 1 decimal place]

**X<sub>1...6</sub>** Total length [m] of liquid piping size at **Øa**

**A** Parameter A

**Parameter A.** If the total indoor unit capacity connection ratio (CR) > 100%, charge an additional 0.5 kg of refrigerant per outdoor unit.

#### In case of heat recovery system

##### Formula:

$$R = [(X_1 \times \text{Ø}22.2) \times 0.37 + (X_2 \times \text{Ø}19.1) \times 0.26 + (X_3 \times \text{Ø}15.9) \times 0.18 + (X_4 \times \text{Ø}12.7) \times 0.12 + (X_5 \times \text{Ø}9.5) \times 0.059 + (X_6 \times \text{Ø}6.4) \times 0.022] \times 1.04 + A + C$$

**R** Additional refrigerant to be charged [in kg and rounded off to 1 decimal place]

**X<sub>1...6</sub>** Total length [m] of liquid piping size at **Øa**

**A** Parameter A

**C** Parameter C

**Parameter A.** If the total indoor unit capacity connection ratio (CR) > 100%, charge an additional 0.5 kg of refrigerant per outdoor unit.

**Parameter C.** When using more than one multi BS unit, add the sum of the individual BS unit charge factors.

Model	C
BS1Q10	0.05 kg
BS1Q16	0.1 kg
BS1Q25	0.2 kg
BS4Q	0.3 kg
BS6Q	0.4 kg
BS8Q	0.5 kg
BS10Q	0.7 kg
BS12Q	0.8 kg

Model	C
BS16Q	1.1 kg

**Metric piping.** When using metric piping, replace the weight factors in the formula by the ones from the following table:

Inch piping		Metric piping	
Piping	Weight factor	Piping	Weight factor
Ø6.4 mm	0.022	Ø6 mm	0.018
Ø9.5 mm	0.059	Ø10 mm	0.065
Ø12.7 mm	0.12	Ø12 mm	0.097
Ø15.9 mm	0.18	Ø15 mm	0.16
		Ø16 mm	0.18
Ø19.1 mm	0.26	Ø18 mm	0.24
Ø22.2 mm	0.37	Ø22 mm	0.35

**Connection ratio requirements.** When selecting indoor units, the connection ratio must comply with the following requirements. For more information, see the technical engineering data.

### 6.6.4 To charge refrigerant

Follow the steps as described below.

#### Pre-charging refrigerant

- 1 Calculate the additional amount of refrigerant to be added using the formula mentioned in "6.6.3 To determine the additional refrigerant amount" on page 29.
- 2 The first 10 kg of additional refrigerant can be pre-charged without outdoor unit operation:

If	Then
The additional refrigerant amount is smaller than 10 kg	Perform steps 3~4.
The additional refrigerant charge is larger than 10 kg	Perform steps 3~6.

- 3 Pre-charging can be done without compressor operation, by connecting the refrigerant bottle to the service port of the liquid stop valve (open valve B). Make sure that all outdoor unit stop valves, as well as valves A, C, and D are closed.



#### NOTICE

During pre-charging, the refrigerant is charged through the liquid line only. Close valves C, D, and A and disconnect the manifold from the gas line and the high pressure/low pressure gas line.

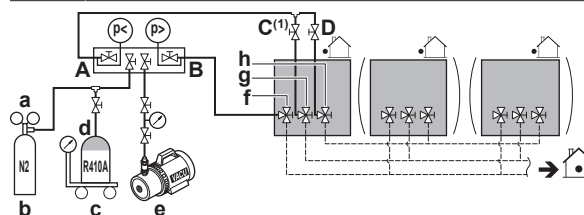

- a Pressure reducing valve
- b Nitrogen
- c Weighing scales
- d Refrigerant R410A tank (siphon system)
- e Vacuum pump
- f Liquid line stop valve
- g Gas line stop valve
- h High pressure/low pressure gas line stop valve
- A Valve A
- B Valve B
- C Valve C<sup>(1)</sup>
- D Valve D

- (1) Only for heat recovery system.

## 6 Installation

### NOTICE

Do not connect the vacuum pump to the suction gas stop valve if the unit is intended to run as a heat pump system. This will increase the risk of unit failure.

4 Do one of the following:

	If	Then
4a	The calculated additional refrigerant amount is reached by above pre-charging procedure	Close valve B and disconnect the manifold from the liquid line.
4b	The total amount of refrigerant could not be charged by pre-charging	Close valve B, disconnect the manifold from the liquid line, and perform steps 5~6.

### INFORMATION

If the total additional refrigerant amount was reached in step 4 (by pre-charging only), record the amount of refrigerant that was added on the additional refrigerant charge label provided with the unit and attach it on the back side of the front panel.

Perform the test procedure as described in "8 Commissioning" on page 40.

### Charging refrigerant

5 After pre-charging, connect valve A to the refrigerant charge port and charge the remaining additional refrigerant through this port. Open all outdoor unit stop valves. At this point, valve A must remain closed!

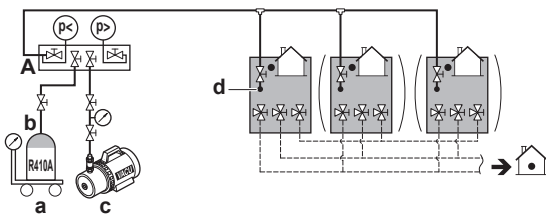

- a Weighing scales
- b Refrigerant R410A tank (siphon system)
- c Vacuum pump
- d Refrigerant charge port
- A Valve A

### INFORMATION

For a multi outdoor unit system, it is not required to connect all charge ports to a refrigerant tank.

The refrigerant will be charged with  $\pm 22$  kg in 1 hour time at an outdoor temperature of  $30^{\circ}\text{C}$  DB or with  $\pm 6$  kg at an outdoor temperature of  $0^{\circ}\text{C}$  DB.

If you need to speed up in case of a multiple outdoor system, connect the refrigerant tanks to each outdoor unit.

### NOTICE

- The refrigerant charging port is connected to the piping inside the unit. The unit's internal piping is already factory charged with refrigerant, so be careful when connecting the charge hose.
- After adding the refrigerant, do not forget to close the lid of the refrigerant charging port. The tightening torque for the lid is 11.5 to 13.9 N·m.
- In order to ensure uniform refrigerant distribution, it may take the compressor  $\pm 10$  minutes to start up after the unit has started operation. This is not a malfunction.

The remaining additional refrigerant charge can be charged by operating the outdoor unit by means of the manual refrigerant charge operation mode:

- 6 Take all the precautions mentioned in "7 Configuration" on page 35 and "8 Commissioning" on page 40 into account.
- 7 Turn on the power of the indoor units and outdoor unit.
- 8 Activate outdoor unit setting [2-20]=1 to start manual refrigerant charge mode. Refer to "7.2.8 Mode 2: Field settings" on page 38 for details.

**Result:** The unit will start operation.

- 9 Valve A can be opened. Charging of remaining additional refrigerant can be done.
- 10 When the remaining calculated additional refrigerant amount is added, close valve A and push BS3 to stop the manual refrigerant charging procedure.

### INFORMATION

The manual refrigerant charge operation will automatically stop within 30 minutes. If charging is not completed after 30 minutes, perform the additional refrigerant charging operation again.

- 11 Perform the test procedure as described in "8 Commissioning" on page 40.

### INFORMATION

After charging refrigerant:

- Record the additional refrigerant amount on the refrigerant label provided with the unit and attach it to the backside of the front panel.
- Perform the test procedure described in "8 Commissioning" on page 40.

### INFORMATION

Aborting the manual refrigerant charge is possible by pushing BS3. The unit will stop and return to idle condition.

### 6.6.5 Checks after charging refrigerant

- Are all stop valves open?
- Is the amount of refrigerant, that has been added, recorded on the refrigerant charge label?

### NOTICE

Make sure to open all stop valves after (pre-) charging the refrigerant.

Operating with the stop valves closed will damage the compressor.

### 6.6.6 To fix the fluorinated greenhouse gases label

1 Fill in the label as follows:

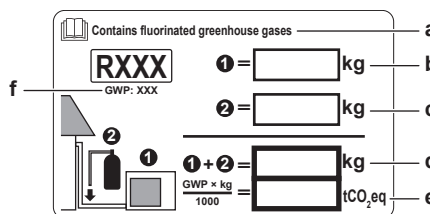

- a If a multilingual fluorinated greenhouse gases label is delivered with the unit (see accessories), peel off the applicable language and stick it on top of a.
- b Factory refrigerant charge: see unit name plate
- c Additional refrigerant amount charged
- d Total refrigerant charge
- e **Greenhouse gas emissions** of the total refrigerant charge expressed as tonnes CO<sub>2</sub> equivalent
- f GWP = Global warming potential

**NOTICE**

In Europe, the **greenhouse gas emissions** of the total refrigerant charge in the system (expressed as tonnes CO<sub>2</sub> equivalent) is used to determine the maintenance intervals. Follow the applicable legislation.

**Formula to calculate the greenhouse gas emissions:**  
GWP value of the refrigerant × Total refrigerant charge [in kg] / 1000

- 2 Fix the label on the inside of the outdoor unit near the gas and liquid stop valves.

## 6.7 Connecting the water piping

### 6.7.1 About connecting the water piping

#### Before connecting the water piping

Make sure the outdoor and indoor units are mounted.

#### Typical workflow

Connecting the water piping typically consists of the following stages:

- 1 Connecting the water piping of the outdoor unit.
- 2 Filling the water circuit.
- 3 Insulating the water piping.

### 6.7.2 Precautions when connecting the water piping

**INFORMATION**

Also read the precautions and requirements in the following chapters:

- General safety precautions
- Preparation

### 6.7.3 To connect the water piping

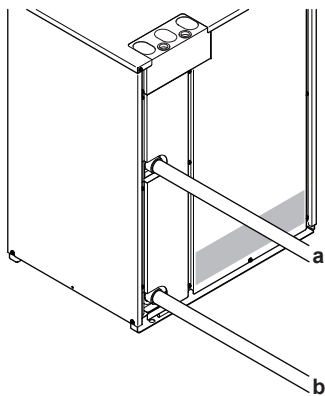

- a Cooling water outlet  
b Cooling water inlet

Consult "5.4.2 Water circuit requirements" on page 19 for the correct tightening torque of the water piping connections.

### 6.7.4 To fill the water circuit

- 1 Connect the water supply hose to the fill valve (field supply).
- 2 Open the fill valve.
- 3 Run the pump **ONLY** and make sure that no air has been caught in the water circulation system otherwise the plate heat exchanger will freeze.

- 4 Check if the water flow rate is correct, otherwise the plate heat exchanger will freeze. Measure any water pressure loss before and after running the pump and make sure that the flow rate is correct. If not, stop the pump immediately and carry out troubleshooting.

### 6.7.5 To insulate the water piping

The outdoor water piping **MUST** be insulated to prevent condensation during cooling operation and reduction of the heating and cooling capacity.

See "5.4.2 Water circuit requirements" on page 19 for more information.

## 6.8 Connecting the electrical wiring

### 6.8.1 Precautions when connecting electrical wiring

**DANGER: RISK OF ELECTROCUTION****WARNING**

All field wiring and components **MUST** be installed by a licensed electrician and **MUST** comply with the applicable legislation.

**WARNING**

If **NOT** factory installed, a main switch or other means for disconnection, having a contact separation in all poles providing full disconnection under overvoltage category III condition, **MUST** be installed in the fixed wiring.

**WARNING**

- **ONLY** use copper wires.
- Make sure the field wiring complies with the applicable legislation.
- All field wiring **MUST** be performed in accordance with the wiring diagram supplied with the product.
- **NEVER** squeeze bundled cables and make sure they do **NOT** come in contact with the piping and sharp edges. Make sure no external pressure is applied to the terminal connections.
- Make sure to install earth wiring. Do **NOT** earth the unit to a utility pipe, surge absorber, or telephone earth. Incomplete earth may cause electrical shock.
- Make sure to use a dedicated power circuit. **NEVER** use a power supply shared by another appliance.
- Make sure to install the required fuses or circuit breakers.
- Make sure to install an earth leakage protector. Failure to do so may cause electric shock or fire.
- When installing the earth leakage protector, make sure it is compatible with the inverter (resistant to high frequency electric noise) to avoid unnecessary opening of the earth leakage protector.

Install power cables at least 1 m away from televisions or radios to prevent interference. Depending on the radio waves, a distance of 1 m may not be sufficient.

## 6 Installation



### WARNING

- After finishing the electrical work, confirm that each electrical component and terminal inside the electrical components box is connected securely.
- Make sure all covers are closed before starting up the unit.



### NOTICE

Do NOT operate the unit until the refrigerant piping is complete. Running the unit before the piping is ready will break the compressor.



### NOTICE

If the power supply has a missing or wrong N-phase, equipment will break down.



### NOTICE

Do NOT install a phase advancing capacitor, because this unit is equipped with an inverter. A phase advancing capacitor will reduce performance and may cause accidents.



### NOTICE

NEVER remove a thermistor, sensor, etc., when connecting power wiring and transmission wiring. (If operated without thermistor, sensor, etc., the compressor may break down.)

### 6.8.2 Field wiring: Overview

#### In case of heat pump system

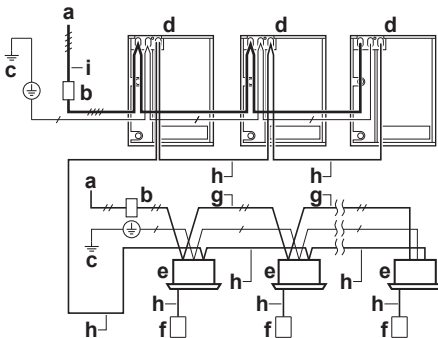

- a Field power supply (with earth leakage protector)
  - b Main switch
  - c Earth connection
  - d Outdoor unit
  - e Indoor unit
  - f User interface
  - g Indoor power supply wiring (sheathed cable) (230 V)
  - h Transmission wiring (sheathed cable) (16 V)
  - i Outdoor power supply wiring (sheathed cable)
- Power supply 3N~ 50 Hz  
 Power supply 1~ 50 Hz  
 Earth wiring

#### In case of heat recovery system

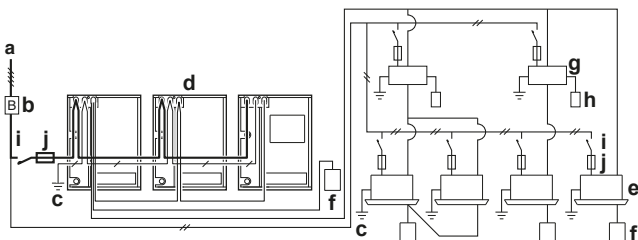

- a Field power supply (with earth leakage protector)
- b Main switch
- c Earth connection
- d Outdoor unit
- e Indoor unit
- f User interface

- g BS unit
  - h Cool/heat selector
  - i Circuit breaker
  - j Fuse
- Power supply 3N~ 50 Hz  
 Power supply 1~ 50 Hz  
 Earth wiring

### 6.8.3 About the electrical wiring

It is important to keep the power supply and the transmission wiring separated from each other. In order to avoid any electrical interference the distance between both wiring should always be at least 25 mm.



### NOTICE

- Be sure to keep the power line and transmission line apart from each other. Transmission wiring and power supply wiring may cross, but may not run parallel.
- Transmission wiring and power supply wiring may not touch internal piping (except the inverter PCB cooling pipe) in order to avoid wire damage due to high temperature piping.
- Firmly close the lid and arrange the electrical wires so as to prevent the lid or other parts from coming loose.

The transmission wiring outside the unit should be wrapped and routed together with the field piping.

Be sure to follow the limits below. If the unit-to-unit cables are beyond these limits, it may result in malfunction of transmission:

Description	Limitation
Maximum wiring length	1000 m
Total wiring length	2000 m
Maximum inter unit wiring length between outdoor units	30 m
Transmission wiring to cool/heat selector	500 m
Maximum number of branches for unit-to-unit cabling <sup>(a)</sup>	16
Maximum number of independent interconnectable systems	10

(a) No branching is allowed after branching (see figure below).

#### In case of heat pump system

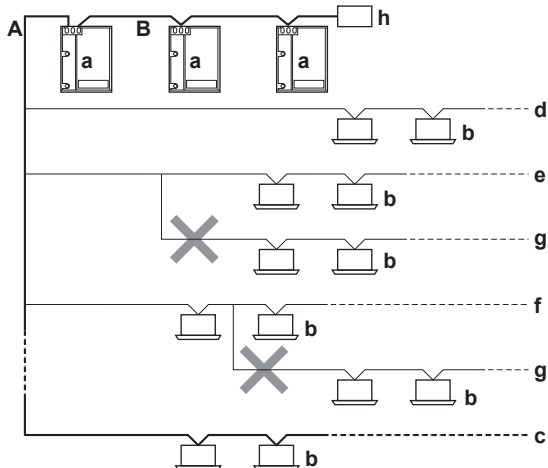

- a Outdoor unit
- b Indoor unit + BS unit
- c Main line
- d Branch line 1
- e Branch line 2
- f Branch line 3
- g No branch is allowed after branch
- h Central user interface (etc...)
- A Outdoor/indoor transmission wiring
- B Master/slave transmission wiring



In case of heat recovery system

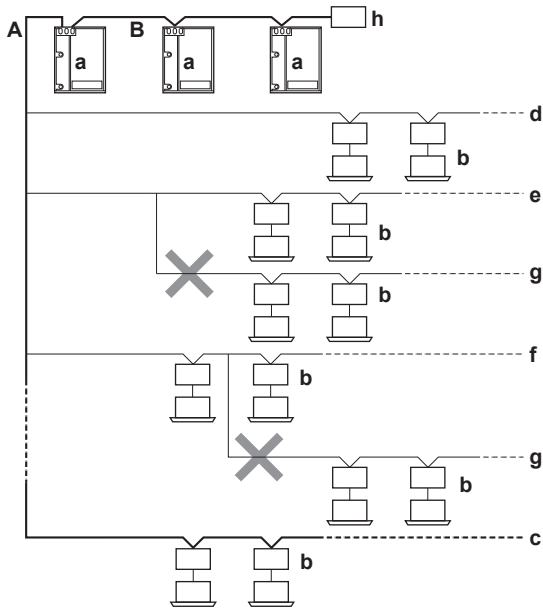

- a Outdoor unit
- b Indoor unit
- c Main line
- d Branch line 1
- e Branch line 2
- f Branch line 3
- g No branch is allowed after branch
- h Central user interface (etc...)
- A Outdoor/indoor transmission wiring
- B Master/slave transmission wiring

For the above wiring, always use vinyl cords with 0.75 mm<sup>2</sup> to 1.25 mm<sup>2</sup> sheath or cables (2-core wires). 3-core wire cables are only allowable for the cooler/heater changeover user interface.

6.8.4 To route and fix the transmission wiring

Transmission wiring can be routed through the front side only. Fix it to the upper mounting hole.

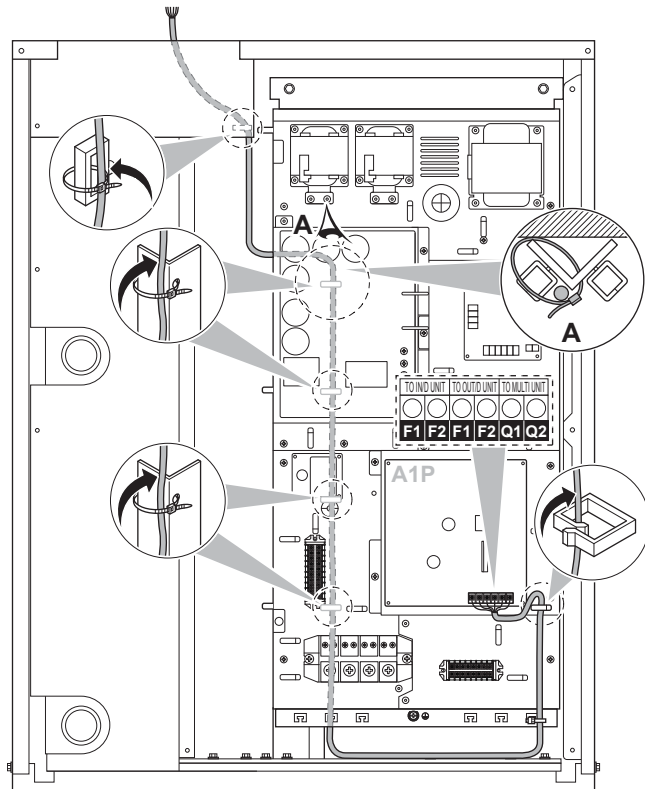

Fix to the indicated plastic brackets (factory installed).

6.8.5 To connect the transmission wiring

The wiring from the indoor units must be connected to the F1/F2 (In-Out) terminals on the PCB in the outdoor unit.

Tightening torque for the transmission wiring terminal screws:

Screw size	Tightening torque (N·m)
M3.5 (A1P)	0.8~0.96

In case of heat pump system

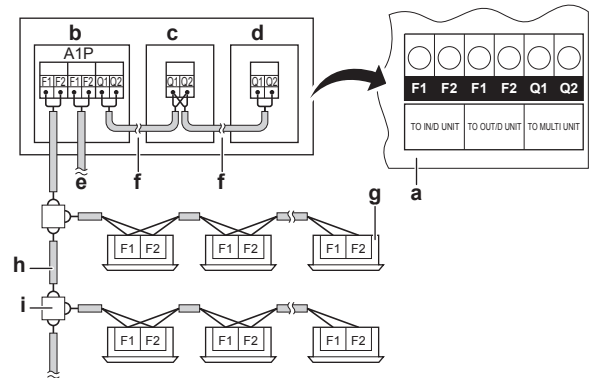

- a Outdoor unit PCB (A1P)
- b Unit A (master outdoor unit)
- c Unit B (slave outdoor unit)
- d Unit C (slave outdoor unit)
- e Outdoor unit/other system transmission (F1/F2)
- f Outdoor-outdoor unit transmission (Q1/Q2)
- g Indoor unit
- h Use the conductor of sheathed wire (2 wire) (no polarity)
- i Terminal board (field supply)

In case of heat recovery system

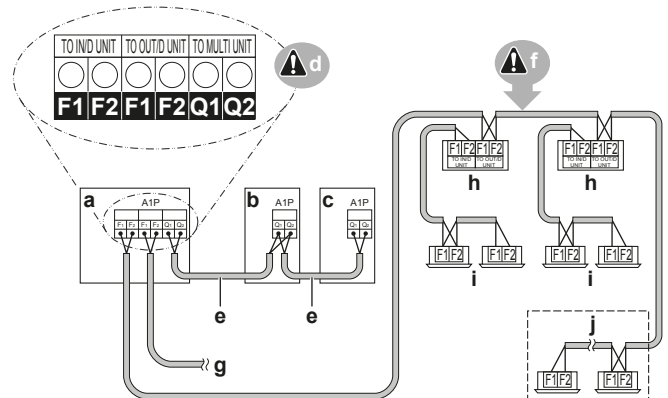

- a Unit A (master outdoor unit)
- b Unit B (slave outdoor unit)
- c Unit C (slave outdoor unit)
- d Outdoor unit PCB (A1P)
- e Master/slave transmission (Q1/Q2)
- f Outdoor/indoor transmission (F1/F2)
- g Outdoor unit/other system transmission (F1/F2)
- h BS unit
- i Indoor unit
- j Cooling-only VRV indoor unit / Heating-only Hydrobox unit

- The interconnecting wiring between the outdoor units in the same piping system must be connected to the Q1/Q2 (Out Multi) terminals. Connecting the wires to the F1/F2 terminals results in system malfunction.
- The wiring for the other systems must be connected to the F1/F2 (Out-Out) terminals of the PCB in the outdoor unit to which the interconnecting wiring for the indoor units is connected.
- The base unit is the outdoor unit to which the interconnecting wiring for the indoor units is connected.

## 6 Installation

### 6.8.6 To finish the transmission wiring

After installing the transmission wires inside the unit, wrap them along with the on-site refrigerant pipes using finishing tape, as shown in figure below.

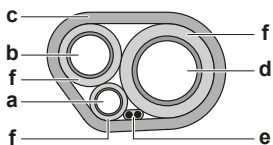

- a Liquid pipe
- b Gas pipe
- c Finishing tape
- d High pressure/low pressure gas pipe
- e Transmission wiring (F1/F2)
- f Insulator

### 6.8.7 To route and fix the power supply

#### NOTICE

When routing earth wires, secure clearance of 25 mm or more away from compressor lead wires. Failure to observe this instruction properly may adversely affect correct operation of other units connected to the same earth.

The power supply wiring can be routed from the front side. Exit the wiring via the upper mounting hole.

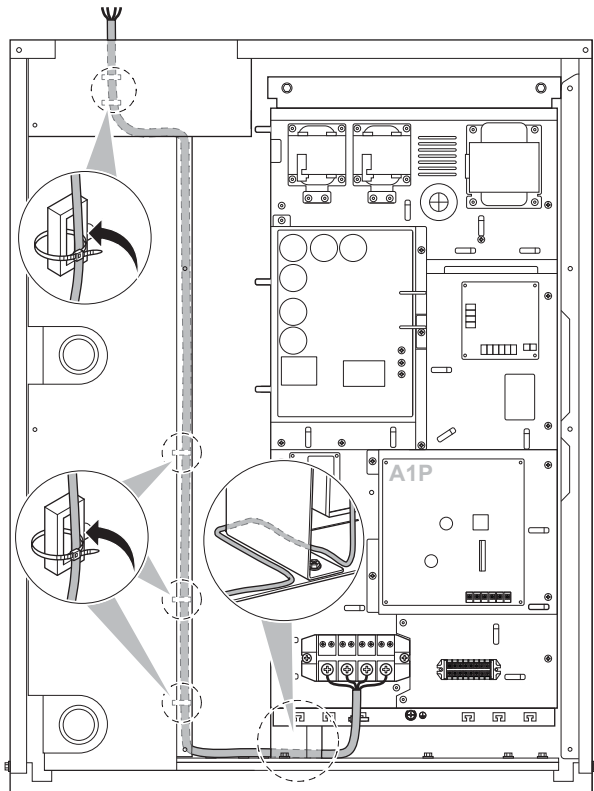

### 6.8.8 To connect the power supply

#### NOTICE

Never connect the power supply to transmission wiring terminal block. Otherwise the entire system may break down.

#### CAUTION

When connecting the power supply, the earth connection must be made before the current-carrying connections are established. When disconnecting the power supply, the current-carrying connections must be separated before the earth connection is. The length of the conductors between the power supply stress relief and the terminal block itself must be as such that the current-carrying wires are tightened before the earth wire is in case the power supply is pulled loose from the stress relief.

Tightening torque for the terminal screws:

Screw size	Tightening torque (N·m)
M8 (power terminal block)	5.5~7.3
M8 (ground)	

#### NOTICE

Recommendations when connecting the earth wire:

Wire it so that it comes through the cut out section of the cup washer. (An improper earth connection may prevent a good earthing from being achieved.)

The power supply MUST be clamped to the plastic bracket using field supplied clamp material to prevent external force being applied to the terminal. The green and yellow striped wire MUST be used for earthing only.

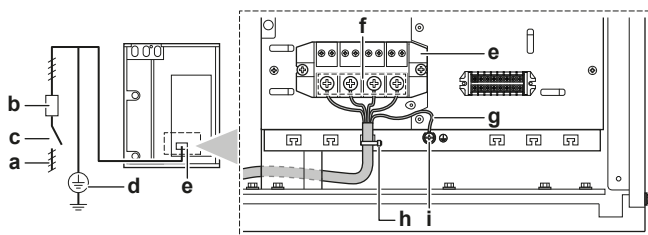

- a Power supply (380~415 V, 3N~ 50 Hz OR 400 V, 3N~ 60 Hz)
- b Fuse
- c Earth leakage protector
- d Earth wire
- e Power supply terminal block
- f Connect each power wire: RED to L1, WHT to L2, BLK to L3 and BLU to N
- g Earth wire (GRN/YLW). When connecting the earth wire, it is recommended to perform curling.
- h Clamp the power supply to the bracket using a field supplied clamp to prevent external force being applied to the terminal.
- i Cup washer.

#### Multiple outdoor units

To connect the power supply for multiple outdoor units to each other, ring tongues have to be used. No bare cable can be used.

In that case, the ring washer that is installed by default should be removed.

Attach both cables to the power supply terminal as indicated below:

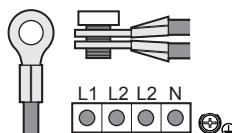

### 6.8.9 To connect the optional wiring

For the optional wiring use insulated wires of a rated voltage of 250 V or higher and a minimal cross section of 1.25 mm<sup>2</sup> for single core wires and 0.75 mm<sup>2</sup> for multicore wires.

### Variable water flow

The variable water flow output signal is a low voltage control signal which generates an output of 2~10 V DC depending on the required water flow rate through the plate heat exchanger. For more information, see "5.4.4 About the water flow rate" on page 20.

#### NOTICE

The maximum output power of the 2~10 V DC output signal is 50 mW. Exceeding this power can result in damage of the system.

Always use shielded cables with a minimal cross section of 0.75 mm<sup>2</sup> and a length limited to 100 m.

The control line of the valve/pump should be connected to the X2M connector in the electrical switchbox. To connect the valve/pump to the outdoor unit, also provide a separate 12 V DC power supply (with an output power of at least 50 mW) to the X2M connector.

Connect the valve/pump to: X2M terminals 2 and 3.

Connect the power source to X2M terminals 1 and 3 (respect the polarity).

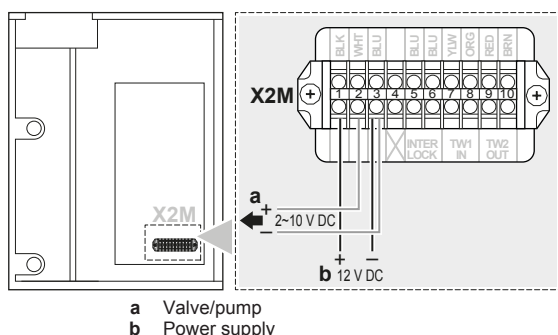

#### NOTICE

Make sure to connect a flow switch to your water-cooled VRV IV system. Running the system with a flow rate below the minimum requirement can result in damage of the system.

### Interlock

It is mandatory to connect a flow switch to the interlock circuit of the outdoor unit. Running the system with a flow rate below the minimum requirement can result in damage of the system. The flow switch should be installed in the main water circuit between the plate heat exchanger and the closed valve. Select a flow switch contact of at least 15 V DC, 1 mA.

Connect the flow switch to: X2M terminals 5 and 6.

In case of a multi outdoor unit system, install one or more flow switches depending on the installation of the water system so that water flow is guaranteed under every condition.

#### NOTICE

If the flow switch is installed in a variable water flow system, take into account the inertia of the water flow. If a variable water flow system is used, the flow switch control should be linked to the compressor operation using the multifunction output terminal "b".

Failure to do so will result in unintended "forced thermo off" conditions.

#### Example:

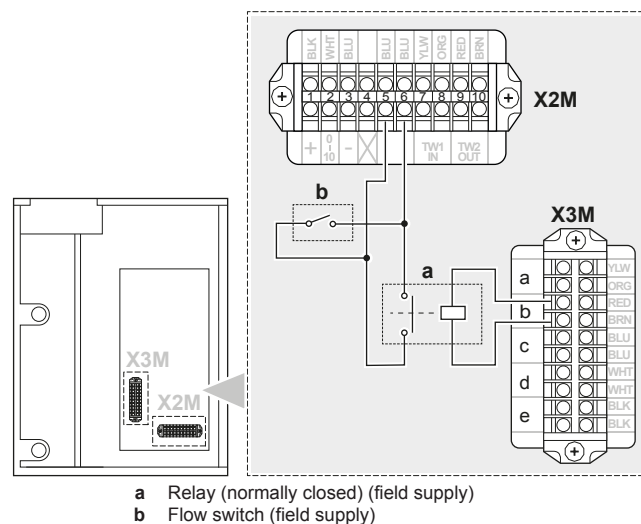

### Multifunction outputs

To monitor the outdoor unit operation or trigger field supplied equipment connected to the outdoor unit, this RWEYQ\*T9, series is equipped with 5 output contacts.

General contact specifications: 220 V AC, 3 mA-0.5 A.

To connect these output signals, choose the applicable contacts in the X3M terminal in the table below:

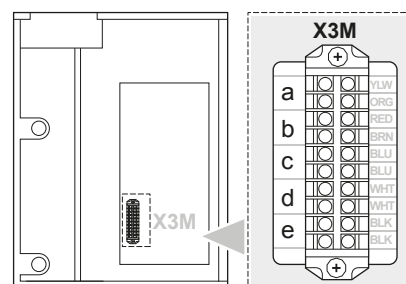

Terminal	Function
a	Error on remote controller
b	Compressor operation
c	Heating operation
d	Cooling operation
e	Water pump operation request

## 7 Configuration

### 7.1 Overview: Configuration

This chapter describes what you have to do and know to configure the system after it is installed.

It contains information about:

- Making field settings
- Energy saving and optimum operation
- Using the leak detection function



#### INFORMATION

It is important that all information in this chapter is read sequentially by the installer and that the system is configured as applicable.



#### DANGER: RISK OF ELECTROCUTION

## 7 Configuration

### 7.2 Making field settings

#### 7.2.1 About making field settings

To continue the configuration of the VRV IV heat recovery system, it is required to give some input to the PCB of the unit. This chapter will describe how manual input is possible by operating the push buttons on the PCB and reading the feedback from the 7-segment displays.

Making settings is done via the master outdoor unit.

Next to making field settings it is also possible to confirm the current operation parameters of the unit.

##### Push buttons

Performing special actions (automatic refrigerant charge, test run, etc.) and making field settings (demand operation, low noise, etc.) happens by way of operating the push buttons.

See also:

- ["7.2.2 Field setting components" on page 36](#)
- ["7.2.3 To access the field setting components" on page 36](#)

##### PC configurator

For VRV IV heat recovery system it is alternatively possible to make several commissioning field settings through a personal computer interface (for this, option EKPCCAB is required). The installer can prepare the configuration (off-site) on PC and afterwards upload the configuration to the system.

See also: ["7.2.9 To connect the PC configurator to the outdoor unit" on page 40.](#)

##### Mode 1 and 2

Mode	Description
Mode 1 (monitoring settings)	Mode 1 can be used to monitor the current situation of the outdoor unit. Some field setting contents can be monitored as well.
Mode 2 (field settings)	<p>Mode 2 is used to change the field settings of the system. Consulting the current field setting value and changing the current field setting value is possible.</p> <p>In general, normal operation can be resumed without special intervention after changing field settings.</p> <p>Some field settings are used for special operation (e.g., 1 time operation, recovery/vacuumping setting, manual adding refrigerant setting, etc.). In such a case, it is required to abort the special operation before normal operation can restart. It will be indicated in below explanations.</p>

See also:

- ["7.2.4 To access mode 1 or 2" on page 36](#)
- ["7.2.5 To use mode 1" on page 37](#)
- ["7.2.6 To use mode 2" on page 37](#)
- ["7.2.7 Mode 1: Monitoring settings" on page 38](#)
- ["7.2.8 Mode 2: Field settings" on page 38](#)

#### 7.2.2 Field setting components

Location of the 7-segment displays, buttons and DIP switches:

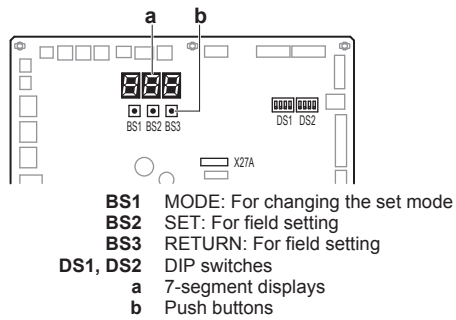

#### 7.2.3 To access the field setting components

It is not required to open the complete electronic component box to access the push buttons on the PCB and read out the 7-segment display(s).

To access you can remove the front inspection cover of the front plate (see figure). Now you can open the inspection cover of the electrical component box front plate (see figure). You can see the three push buttons and the three 7-segment displays and DIP switches.

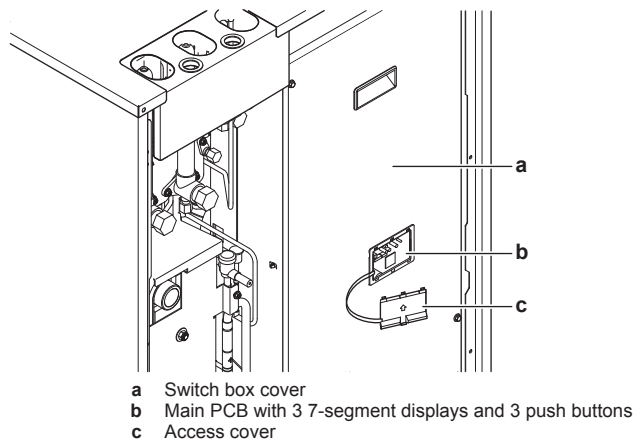

Operate the switches and push buttons with an insulated stick (such as a closed ball-point pen) to avoid touching of live parts.



Make sure to re-attach the inspection cover into the electronic component box cover and to close the front plate's inspection cover after the job is finished. During operation of the unit the front plate of the unit should be attached. Settings are still possible to be made through the inspection opening.



##### NOTICE

Make sure that all outside panels, except for the service cover on the electrical component box, are closed while working.

Close the lid of the electrical component box firmly before turning on the power.

#### 7.2.4 To access mode 1 or 2

##### Initialisation: default situation



##### NOTICE

Be sure to turn on the power 6 hours before operation in order to have power running to the crankcase heater and to protect the compressor.

Turn on the power supply of the outdoor unit and all indoor units. When the communication between indoor units and outdoor unit(s) is established and normal, the 7-segment display indication state will be as below (default situation when shipped from factory).

Stage	Display
When turning on the power supply: flashing as indicated. First checks on power supply are executed (1~2 min).	
When no trouble occurs: lighted as indicated (8~10 min).	
Ready for operation: blank display indication as indicated.	

7-segment display indications:

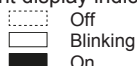

When above situation cannot be confirmed after 12 min, the malfunction code can be checked on the indoor unit user interface and the outdoor unit 7-segment display. Solve the malfunction code accordingly. The communication wiring should be checked at first.

### Access

BS1 is used to change the mode you want to access.

Access	Action
Mode 1	Push BS1 one time. 7-segment display indication changes to: 
Mode 2	Push BS1 for at least 5 seconds. 7-segment display indication changes to: 

### **i** INFORMATION

If you get confused in the middle of the process, push BS1. Then it returns to idle situation (no indication on 7-segment displays: blank, refer to "7.2.4 To access mode 1 or 2" on page 36.

## 7.2.5 To use mode 1

Mode 1 is used to set basic settings and to monitor the status of the unit.

What	How
Changing and accessing the setting in mode 1	Once mode 1 is selected (push BS1 one time), you can select the wanted setting. It is done by pushing BS2.  Accessing the selected setting's value is done by pushing BS3 one time.
To quit and return to the initial status	Press BS1.

### Example:

Checking the content of parameter [1-10] (to know how many indoor units are connected to the system).

[A-B]=C in this case defined as: A=1; B=10; C=the value we want to know/monitor:

- 1 Make sure the 7-segment display indication is as during normal operation (default situation when shipped from factory).
- 2 Push BS1 one time.

**Result:** Mode 1 is accessed:

- 3 Push BS2 10 times.

**Result:** Mode 1 setting 10 is addressed:

- 4 Push BS3 one time; the value which is returned (depending on the actual field situation), is the amount of indoor units which are connected to the system.

**Result:** Mode 1 setting 10 is addressed and selected, return value is monitored information

- 5 To leave the monitoring function, push BS1 one time.

**Result:** You will return to the default situation when shipped from factory.

## 7.2.6 To use mode 2

The master unit should be used to input field settings in mode 2.

Mode 2 is used to set field settings of the outdoor unit and system.

What	How
Changing and accessing the setting in mode 2	Once mode 2 is selected (push BS1 for more than 5 seconds), you can select the wanted setting. It is done by pushing BS2.  Accessing the selected setting's value is done by pushing BS3 1 time.
To quit and return to the initial status	Press BS1.
Changing the value of the selected setting in mode 2	<ul style="list-style-type: none"> <li>Once mode 2 is selected (push BS1 for more than 5 seconds) you can select the wanted setting. It is done by pushing BS2.</li> <li>Accessing the selected setting's value is done by pushing BS3 1 time.</li> <li>Now BS2 is used to select the required value of the selected setting.</li> <li>When the required value is selected, you can define the change of value by pushing BS3 1 time.</li> <li>Press BS3 again to start operation according to the chosen value.</li> </ul>

### Example:

Checking the content of parameter [2-12].

[A-B]=C in this case defined as: A=2; B=12; C=the value we want to know/change

- 1 Make sure the 7-segment display indication is as during normal operation (default situation when shipped from factory).
- 2 Push BS1 for over 5 seconds.

**Result:** Mode 2 is accessed:

- 3 Push BS2 12 times.

**Result:** Mode 2 setting 12 is addressed:

- 4 Push BS3 1 time; the value which is returned (depending on the actual field situation), is the status of the setting. In the case of [2-12], default value is "0", which means the function is not active.

**Result:** Mode 2 setting 12 is addressed and selected, return value is the current setting situation.

- 5 To change the value of the setting, push BS2 till the required value appears on the 7-segment display indication. When achieved, define the setting value by pushing BS3 1 time. To start operation according to the chosen setting, confirm again by pushing BS3.

- 6 To leave the monitoring function, push BS1 2 times.

## 7 Configuration

**Result:** You will return to the default situation when shipped from factory.

### 7.2.7 Mode 1: Monitoring settings

#### [1-0]

Shows whether the unit you check is a master, slave 1 or slave 2 unit.

Master, slave 1 and slave 2 indications are relevant in multiple outdoor unit system configurations. The allocation of which outdoor unit is master, slave 1 or slave 2 are decided by the unit's logic.

**The master unit should be used to input field settings in mode 2.**

[1-0]	Description
No indication	Undefined situation.
0	Outdoor unit is master unit.
1	Outdoor unit is slave 1 unit.
2	Outdoor unit is slave 2 unit.

#### [1-2]

Shows the status of power consumption limitation operation.

Power consumption limitation reduces the power consumption of the unit compared to nominal operating conditions.

[1-2]	Description
0	Unit is currently not operating under power consumption limitations.
1	Unit is currently operating under power consumption limitation.

Power consumption limitation can be set in mode 2. There are two methods to activate power consumption limitation of the outdoor unit system.

- The first method is to enable a forced power consumption limitation by field setting. The unit will always operate at the selected power consumption limitation.
- The second method is to enable power consumption limitation based on an external input. For this operation an optional accessory is required.

#### [1-5] [1-6]

Shows:

- [1-5]: The current  $T_e$  target parameter position.
- [1-6]: The current  $T_c$  target parameter position.

#### [1-13]

Shows the total number of connected outdoor units (in case of multiple outdoor system).

It can be convenient to check if the total number of outdoor units which are installed matches the total number of outdoor units which are recognised by the system. In case there is a mismatch, it is recommended to check the communication wiring path between outdoor and indoor units (Q1/Q2 communication line).

#### [1-17] [1-18] [1-19]

Shows:

- [1-17]: The latest malfunction code.
- [1-18]: The 2nd last malfunction code.
- [1-19]: The 3rd last malfunction code.

When the latest malfunction codes were reset by accident on an indoor unit user interface, they can be checked again through this monitoring settings.

For the content or reason behind the malfunction code see ["10.2 Solving problems based on error codes"](#) on page 43, where most relevant malfunction codes are explained. Detailed information about malfunction codes can be consulted in the service manual of this unit.

### 7.2.8 Mode 2: Field settings

#### [2-8]

$T_e$  target temperature during cooling operation without variable refrigerant temperature (VRT) control.

[2-8]	$T_e$ target (°C)
1	3°C
2 (default)	6°C
3	7°C
4	8°C
5	9°C
6	10°C
7	11°C

#### [2-9]

$T_c$  target temperature during heating operation without variable refrigerant temperature (VRT) control.

[2-9]	$T_c$ target (°C)
1	41°C
2	42°C
3	43°C
4	44°C
5	45°C
6 (default)	46°C
7	49°C

#### [2-12]

Enable the power consumption limitation via external control adaptor (DTA104A61/62).

If the system needs to be running under power consumption limitation conditions when an external signal is sent to the unit, this setting should be changed. This setting will only be effective when the optional external control adaptor (DTA104A61/62) is installed.

[2-12]	Description
0 (default)	Deactivated.
1	Activated.

#### [2-20]

Manual additional refrigerant charge.

In order to add the additional refrigerant charge amount in a manual way, following setting should be applied. Further instructions regarding the different ways to charge additional refrigerant into your system can be found in chapter ["6.6.2 About charging refrigerant"](#) on page 29.

[2-20]	Description
0 (default)	Deactivated.
1	Activated. To stop the manual additional refrigerant charge operation (when the required additional refrigerant amount is charged), push BS3. If this function was not aborted by pushing BS3, the unit will stop its operation after 30 minutes. If 30 minutes was not sufficient to add the needed refrigerant amount, the function can be reactivated by changing the field setting again.

**[2-23]**

Variable refrigerant temperature (VRT) control

[2-23]	VRT control
0 (default)	Activated both cooling and heating
1	Activated heating only
2	Activated cooling only
3	Deactivated

**[2-24]**

Water pump/valve control.

To activate the variable flow system, change the setting to the applicable value.

[2-24]	Water pump control
0 (default)	OFF
1	Each unit has a pump/valve
2	One pump/valve per system
3	Each unit has a pump/valve (pump is OFF when slave unit does not operate)

**[2-25]**

Minimum water flow rate limit control.

To change the minimum water flow rate limit of the variable flow system, change the setting to the applicable value. The flow rate limit is according to the table.

[2-25]	Minimum water flow rate limit (%)
0	10%
1	20%
2	30%
3	40%
4 (default)	50%
5	60%
6	70%
7	80%

**[2-30]**

Power consumption limitation level (step 1) via the external control adaptor (DTA104A61/62).

If the system needs to be running under power consumption limitation conditions when an external signal is sent to the unit, this setting defines the level power consumption limitation that will be applied for step 1. The level is according to the table.

[2-30]	Power consumption limitation (approximately)
1	60%
2	65%
3 (default)	70%
4	75%
5	80%
6	85%
7	90%
8	95%

**[2-31]**

Power consumption limitation level (step 2) via the external control adaptor (DTA104A61/62).

If the system needs to be running under power consumption limitation conditions when an external signal is sent to the unit, this setting defines the level power consumption limitation that will be applied for step 2. The level is according to the table.

[2-31]	Power consumption limitation (approximately)
1 (default)	40%
2	50%
3	55%

**[2-32]**

Forced, all time, power consumption limitation operation (no external control adaptor is required to perform power consumption limitation).

If the system always needs to be running under power consumption limitation conditions, this setting activates and defines the level power consumption limitation that will be applied continuously. The level is according to the table.

[2-32]	Restriction reference
0 (default)	Function not active.
1	Follows [2-30] setting.
2	Follows [2-31] setting.

**[2-50]**

Brine type setting.

By changing this setting, you can extend the operation range at the brine side of the unit.

- Normal operation range at brine side (default): for use with water as heat source medium.
- Extended operation range at brine side (default): for use with brine as heat source medium.

**NOTICE**

By changing this setting to extended operation type, glycol (40%) must be used as heat source medium to avoid freeze up of the brine circuit or unit itself (cf. operation range). Do not use water in this case!

[2-50]	Description
0 (default)	No brine: water. Extended range impossible.
1	Use brine: glycol (20%). Extended range possible.
2	Use brine: glycol (30%). Extended range possible.
3	Use brine: glycol (40%). Extended range possible.

**[2-73]**

Zero energy dissipation control setting.

[2-73]	Description
0 (default)	OFF
1	ON (with priority on cooling capacity)
2	ON (with priority on zero energy dissipation)

Zero energy dissipation control can be OFF if the mechanical room is already equipped with a ventilation system or air conditioning system for other facilities.

**[2-74]**

Zero energy dissipation setting temperature.

If the unit internal temperature is higher than the zero energy dissipation setting temperature, the zero energy dissipation control will start and cool down the unit.

[2-74]	Description
0	25°C
1	27°C
2	29°C

## 8 Commissioning

[2-74]	Description
3 (default)	31°C
4	33°C
5	35°C
6	37°C
7	39°C

### [2-81]

Cooling comfort setting.

This setting is used in conjunction with setting [2-8].

[2-81]	Cooling comfort setting
0	Eco
1 (default)	Mild
2	Quick
3	Powerful

### [2-82]

Heating comfort setting.

This setting is used in conjunction with setting [2-9].

[2-82]	Heating comfort setting
0	Eco
1 (default)	Mild
2	Quick
3	Powerful

### 7.2.9 To connect the PC configurator to the outdoor unit

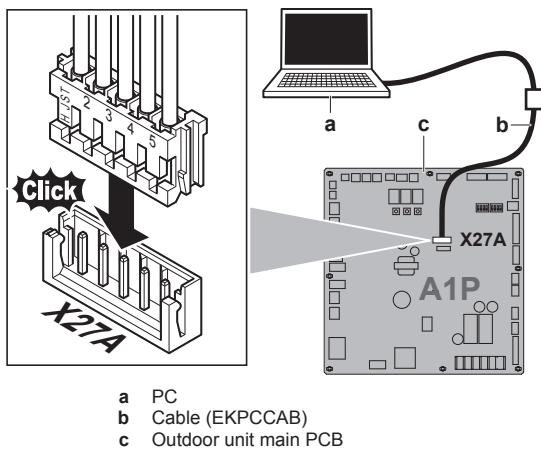

## 8 Commissioning

### 8.1 Overview: Commissioning

After installation and once the field settings are defined, the installer is obliged to verify correct operation. Therefore a test run **MUST** be performed according to the procedures described below.

This chapter describes what you have to do and know to commission the system after it is configured.

Commissioning typically consists of the following stages:

- 1 Checking the "Checklist before commissioning".
- 2 Performing a test run.
- 3 If necessary, correcting errors after abnormal completion of the test run.
- 4 Operating the system.

### 8.2 Precautions when commissioning



**DANGER: RISK OF ELECTROCUTION**



**DANGER: RISK OF BURNING**



**CAUTION**

Do **NOT** perform the test operation while working on the indoor units.

When performing the test operation, **NOT** only the outdoor unit, but the connected indoor unit will operate as well. Working on an indoor unit while performing a test operation is dangerous.



**CAUTION**

Do **NOT** insert fingers, rods or other objects into the air inlet or outlet. Do **NOT** remove the fan guard. When the fan is rotating at high speed, it will cause injury.



**INFORMATION**

During the first running period of the unit, the required power may be higher than stated on the nameplate of the unit. This phenomenon is caused by the compressor, that needs a continuous run time of 50 hours before reaching smooth operation and stable power consumption.



**NOTICE**

Be sure to turn on the power 6 hours before operation in order to have power running to the crankcase heater and to protect the compressor.

During test operation, the outdoor unit and the indoor units will start up. Make sure that the preparations of all indoor units are finished (field piping, electrical wiring, air purge, ...). See installation manual of the indoor units for details.

### 8.3 Checklist before commissioning

After the installation of the unit, first check the following items. Once all below checks are fulfilled, the unit **MUST** be closed, **ONLY** then can the unit be powered up.

<input type="checkbox"/>	You read the complete installation and operation instructions, as described in the <b>installer and user reference guide</b> .
<input type="checkbox"/>	<b>Installation</b> Check that the unit is properly installed, to avoid abnormal noises and vibrations when starting up the unit.
<input type="checkbox"/>	<b>Field wiring</b> Be sure that the field wiring has been carried out according to the instructions described in the chapter <a href="#">"6.8 Connecting the electrical wiring"</a> on page 31, according to the wiring diagrams and according to the applicable legislation.
<input type="checkbox"/>	<b>Power supply voltage</b> Check the power supply voltage on the local supply panel. The voltage <b>MUST</b> correspond to the voltage on the identification label of the unit.
<input type="checkbox"/>	<b>Earth wiring</b> Be sure that the earth wires have been connected properly and that the earth terminals are tightened.
<input type="checkbox"/>	<b>Insulation test of the main power circuit</b> Using a megatester for 500 V, check that the insulation resistance of 2 MΩ or more is attained by applying a voltage of 500 V DC between power terminals and earth. <b>NEVER</b> use the megatester for the transmission wiring.



<input type="checkbox"/>	<b>Fuses, circuit breakers, or protection devices</b> Check that the fuses, circuit breakers, or the locally installed protection devices are of the size and type specified in the chapter <a href="#">"5.5.2 Safety device requirements" on page 22</a> . Be sure that neither a fuse nor a protection device has been bypassed.
<input type="checkbox"/>	<b>Internal wiring</b> Visually check the electrical component box and the inside of the unit on loose connections or damaged electrical components.
<input type="checkbox"/>	<b>Pipe size and pipe insulation</b> Be sure that correct pipe sizes are installed and that the insulation work is properly executed.
<input type="checkbox"/>	<b>Stop valves</b> Be sure that the stop valves are open on both liquid and gas side.
<input type="checkbox"/>	<b>Damaged equipment</b> Check the inside of the unit on damaged components or squeezed pipes.
<input type="checkbox"/>	<b>Refrigerant leak</b> Check the inside of the unit on refrigerant leakage. If there is a refrigerant leak, try to repair the leak. If the repair is unsuccessful, call your local dealer. Do not touch any refrigerant which has leaked out from refrigerant piping connections. This may result in frostbite.
<input type="checkbox"/>	<b>Oil leak</b> Check the compressor for oil leakage. If there is an oil leak, try to repair the leak. If the repairing is unsuccessful, call your local dealer.
<input type="checkbox"/>	<b>Air inlet/outlet</b> Check that the air inlet and outlet of the unit is NOT obstructed by paper sheets, cardboard, or any other material.
<input type="checkbox"/>	<b>Additional refrigerant charge</b> The amount of refrigerant to be added to the unit shall be written on the included "Added refrigerant" plate and attached to the rear side of the front cover.
<input type="checkbox"/>	<b>Installation date and field setting</b> Be sure to keep record of the installation date on the sticker on the rear of the upper front panel according to EN60335-2-40 and keep record of the contents of the field setting(s).
<input type="checkbox"/>	Inspect the <b>water filter</b> at the inlet piping of the outdoor unit. Clean it if it is dirty.
<input type="checkbox"/>	The <b>piping work</b> has been carried out according to this document and the applicable legislation. Make sure that following components are positioned at their correct places: <ul style="list-style-type: none"> <li>▪ water filter,</li> <li>▪ air purge valve,</li> <li>▪ automatic water supply valve, and</li> <li>▪ expansion tank.</li> </ul>
<input type="checkbox"/>	<b>Water circuit</b> Make sure that the water circuit is filled.
<input type="checkbox"/>	<b>Water flow</b> Make sure that the calculated water flow rate can be reached.

## 8.4 About the test run

The procedure below describes the test operation of the complete system. This operation checks and judges following items:

- Check for incorrect wiring (communication check with indoor units).
- Check of the stop valves opening.
- Judgement of piping length.

In case Hydrobox units are present in the system, the pipe length check and the refrigerant situation check will not be performed.

- Make sure to carry out the system test operation after the first installation. Otherwise, the malfunction code **U3** will be displayed on the user interface and normal operation or individual indoor unit test run cannot be carried out.
- Abnormalities on indoor units cannot be checked for each unit separately. After the test operation is finished, check the indoor units one by one by performing a normal operation using the user interface. Refer to the indoor unit installation manual for more details (e.g., Hydrobox) concerning the individual test run.



### INFORMATION

- It may take 10 minutes to achieve a uniform refrigerant state before the compressor starts.
- During the test operation, the refrigerant running sound or the magnetic sound of a solenoid valve may become loud and the display indication may change. These are not malfunctions.

## 8.5 To perform a test run

- 1 Close all front panels in order to not let it be the cause of misjudgement (except the electrical component box inspection opening service cover).
- 2 Make sure all field settings you want are set; see ["7.2 Making field settings" on page 36](#).
- 3 Turn ON the power to the outdoor unit and the connected indoor units.



### NOTICE

Be sure to turn on the power 6 hours before operation in order to have power running to the crankcase heater and to protect the compressor.

- 4 Make sure the default (idle) situation is existing; see ["7.2.4 To access mode 1 or 2" on page 36](#). Push BS2 for 5 seconds or more. The unit will start test operation.

**Result:** The test operation is automatically carried out, the outdoor unit display will indicate "**LO I**" and the indication "Test operation" and "Under centralised control" will display on the user interface of indoor units.

Steps during the automatic system test run procedure:

Step	Description
L01	Control before start up (pressure equalisation)
L02	Cooling start up control
L03	Cooling stable condition
L04	Communication check
L05	Stop valve check
L06	Pipe length check
L07	Refrigerant amount check
L09	Pump down operation
L10	Unit stop

## 9 Maintenance and service

**Note:** During the test operation, it is not possible to stop the unit operation from a user interface. To abort the operation, press BS3. The unit will stop after ±30 seconds.

- 5 Check the test operation results on the outdoor unit 7-segment display.

Completion	Description
Normal completion	No indication on the 7-segment display (idle).
Abnormal completion	Indication of malfunction code on the 7-segment display.  Refer to "8.6 Correcting after abnormal completion of the test run" on page 42 to take actions for correcting the abnormality. When the test operation is fully completed, normal operation will be possible after 5 minutes.

### 8.6 Correcting after abnormal completion of the test run

The test operation is only completed if there is no malfunction code displayed on the user interface or outdoor unit 7-segment display. In case of a displayed malfunction code, perform correcting actions as explained in the malfunction code table. Carry out the test operation again and confirm that the abnormality is properly corrected.



#### INFORMATION

Refer to the installation manual of the indoor unit for detailed malfunction codes related to indoor units.

### 8.7 Operating the unit

Once the unit is installed and test operation of outdoor unit and indoor units is finished, the operation of the system can start.

For operating the indoor unit, the user interface of the indoor unit should be switched ON. Refer to the indoor unit operation manual for more details.

## 9 Maintenance and service



#### NOTICE

Maintenance **MUST** be done by an authorized installer or service agent.

We recommend performing maintenance at least once a year. However, applicable legislation might require shorter maintenance intervals.



#### NOTICE

In Europe, the **greenhouse gas emissions** of the total refrigerant charge in the system (expressed as tonnes CO<sub>2</sub> equivalent) is used to determine the maintenance intervals. Follow the applicable legislation.

**Formula to calculate the greenhouse gas emissions:**  
GWP value of the refrigerant × Total refrigerant charge [in kg] / 1000

### 9.1 Overview: Maintenance and service

This chapter contains information about:

- Preventing electrical hazards when maintaining and servicing the system
- Cleaning the plate heat exchanger
- The refrigerant recovery operation

## 9.2 Maintenance safety precautions



**DANGER: RISK OF ELECTROCUTION**



**DANGER: RISK OF BURNING**



**NOTICE: Risk of electrostatic discharge**

Before performing any maintenance or service work, touch a metal part of the unit in order to eliminate static electricity and to protect the PCB.

### 9.2.1 To prevent electrical hazards

When performing service to inverter equipment:

- 1 Do NOT open the electrical component box cover for 10 minutes after the power supply is turned off.
- 2 Measure the voltage between terminals on the terminal block for power supply with a tester and confirm that the power supply is shut off. In addition, measure points as shown in the figure, with a tester and confirm that the voltage of the capacitor in the main circuit is less than 50 V DC.

### 9.3 Maintenance of the plate heat exchanger

The performance of a plate heat exchanger may decline due to scale accumulation. It may be damaged by freezing due to the decrease in the flow rate. For this reason, it is necessary to carry out programmed maintenance at regular intervals in order to prevent scale.

At the beginning of the season, carry out following inspections:

- water quality test and follow the recommendations as described in "5.4.1 Water quality requirements" on page 19
- clean the water filter,
- water flow rate is correct,
- operational conditions (e.g. pressure, water flow rate, outlet temperature,...) are normal.

#### 9.3.1 To clean the plate heat exchanger

Disassembling and cleaning of the plate heat exchanger is not possible. Please use following steps.

**Prerequisite:** Provide a connection port on the water inlet and on the water outlet and connect a circulation pump in between these 2 connection ports when cleaning with chemicals.

**Prerequisite:** Provide a stop valve in front of the inlet water pipe connection port and a stop valve after the outlet water connection port.

**Prerequisite:** Use a solution with 5% diluted formic, citric, oxalic, acetic or phosphoric acid for cleaning scale. NEVER use hydrochloric, sulphuric or nitric acid because such solutions have a strong corrosive feature.

- 1 Connect the piping for circulation of cleaning chemicals to the inlet piping of the plate heat exchanger.
- 2 Fill a cleaning solution of 50°C~60°C for a while in the plate heat exchanger.
- 3 Circulate for 2~5 hours by using a pump. Time for cleaning depends on the temperature of the cleaning solution or the degree of scale accumulation. Therefore, please watch the change of dirtiness of the cleaning solution to determine the level of removal of scale.
- 4 After circulating the cleaning solution, discharge the solution from the plate heat exchanger.

- 5 Fill the plate heat exchanger with a solution of 1-2% sodium hydroxide (NaOH) or sodium bicarbonate (NaHCO<sub>3</sub>).
- 6 Circulate this solution for 15-20 minutes for neutralization purpose.
- 7 Rinse the inside of the plate heat exchanger with care using fresh and clean water.
- 8 When using any commercially available cleaning agent, check in advance that such agent has no corrosive features against stainless steel and copper. Ask the manufacturer of the cleaning agent for more details.
- 9 Check if the unit can operate in a normal way.

## 9.4 About service mode operation

Refrigerant recovery operation/vacuuming operation is possible by applying setting [2-21]. Refer to "7.2 Making field settings" on page 36 for details how to set mode 2.

When vacuuming/recovery mode is used, check very carefully what should be vacuumed/recovered before starting. See installation manual of the indoor unit for more information about vacuuming and recovery.

### 9.4.1 To use vacuum mode

- 1 When the unit is at standstill, set the unit in [2-21]=1.
 

**Result:** When confirmed, the indoor and outdoor unit expansion valves will fully open. At that moment the 7-segment display indication= $E3$  and the user interface of all indoor units indicate TEST (test operation) and  (external control) and the operation will be prohibited.
- 2 Evacuate the system with a vacuum pump.
- 3 Press BS3 to stop vacuuming mode.

### 9.4.2 To recover refrigerant

This should be done by a refrigerant reclaimer. Follow the same procedure as for vacuuming method.



#### DANGER: RISK OF EXPLOSION

**Pump down – Refrigerant leakage.** If you want to pump down the system, and there is a leak in the refrigerant circuit:

- Do NOT use the unit's automatic pump down function, with which you can collect all refrigerant from the system into the outdoor unit. **Possible consequence:** Self-combustion and explosion of the compressor because of air going into the operating compressor.
- Use a separate recovery system so that the unit's compressor does NOT have to operate.



#### NOTICE

Make sure to NOT recover any oil while recovering refrigerant. **Example:** By using an oil separator.

## 10 Troubleshooting

### 10.1 Overview: Troubleshooting

This chapter describes what you have to do in case of problems.

It contains information about:

- Solving problems based on error codes

### 10.2 Solving problems based on error codes

In case of a displayed malfunction code, perform correcting actions as explained in the malfunction code table.

After correcting the abnormality, press BS3 to reset the malfunction code and retry operation.

The malfunction code which is displayed on the outdoor unit will indicate a main malfunction code and a sub code. The sub code indicates more detailed information about the malfunction code. The malfunction code will be displayed intermittent.

**Example:**

Code	Example
Main code	$E3$
Sub code	$-01$

With an interval of 1 second, the display will switch between main code and sub code.

## 11 Disposal

This unit uses hydrofluorocarbon. Contact your dealer when discarding this unit.



#### NOTICE

Do NOT try to dismantle the system yourself: dismantling of the system, treatment of the refrigerant, oil and other parts MUST comply with applicable legislation. Units MUST be treated at a specialised treatment facility for reuse, recycling and recovery.

## 12 Technical data

A **subset** of the latest technical data is available on the regional Daikin website (publicly accessible). The **full set** of latest technical data is available on the Daikin extranet (authentication required).

### 12.1 Overview: Technical data

This chapter contains information about:

- Service space
- Piping diagram
- Wiring diagram
- Field settings
- ESP curves

### 12.2 Service space: Outdoor unit

Make sure the space around the unit is adequate for servicing and the minimum space for ventilation is available (refer to the figure below).

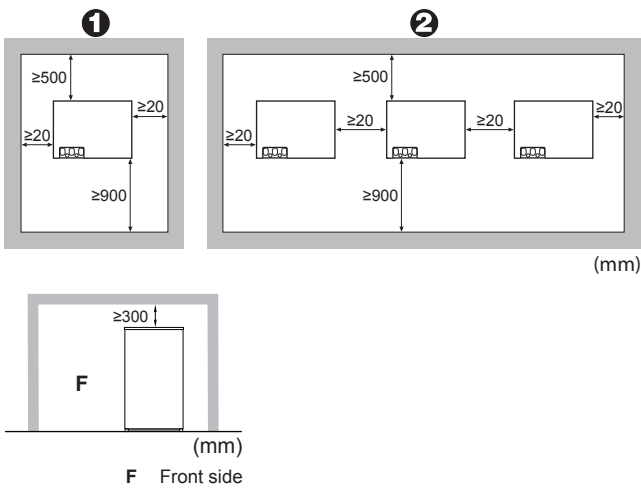

#### **i** INFORMATION

Further specifications can be found in the technical engineering data.

### 12.3 Piping diagram: Outdoor unit

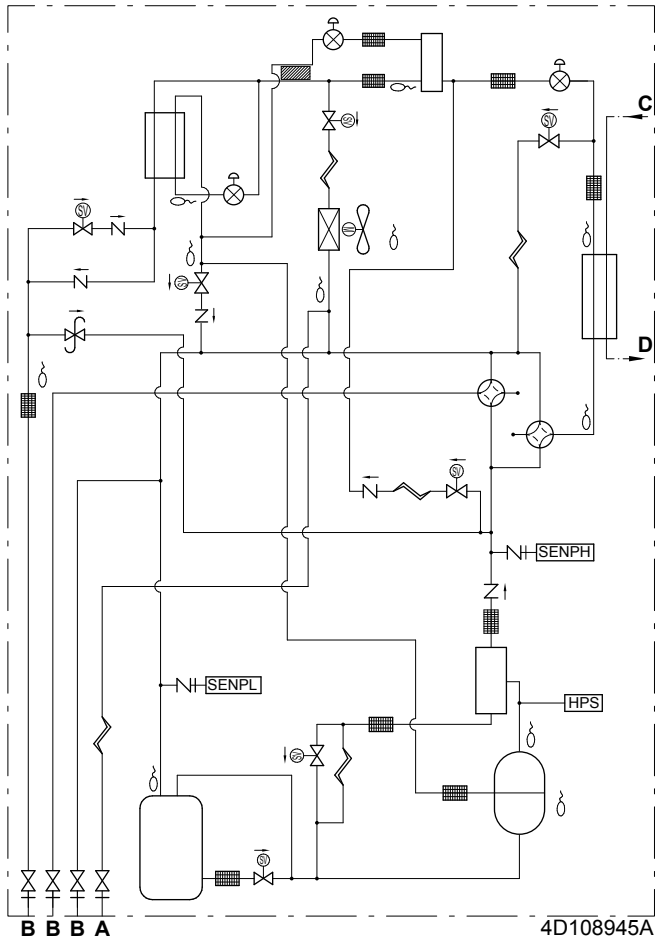

- A** Charge port
- B** Stop valve (with service port  $\varnothing$ 7.9 mm flare connection)
- C** Cooling water inlet
- D** Cooling water outlet
- Charge port / Service port
- Filter
- Check valve
- Pressure relief valve
- Solenoid valve
- Capillary tube
- Electronic expansion valve
- 4-way valve
- Propeller fan
- Port (for sensor)
- Low/high pressure sensor

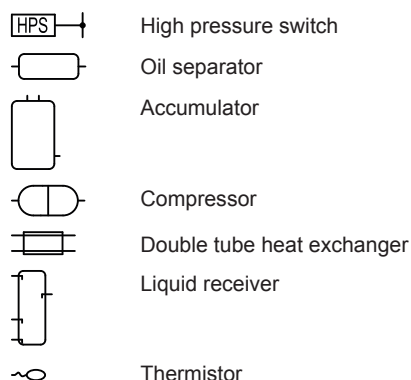

## 12.4 Wiring diagram: Outdoor unit

The wiring diagram is delivered with the unit, located at the inside of the service cover.

### Notes to go through before starting the unit

English	Translation
Notes to go through before starting the unit	Notes to go through before starting the unit
Symbols	Symbols
X1M	Main terminal
-----	Earth wiring
15	Wire number 15
-----	Field wire
	Field cable
→ **/12.2	Connection ** continues on page 12 column 2
①	Several wiring possibilities
	Option
	Not mounted in switch box
	Wiring depending on model
	PCB

- 1 Refer to the installation or service manual on how to use BS1~BS3 push buttons, and DS1+DS2 DIP switches.
- 2 Do not operate the unit by short-circuiting protection device S1PH.
- 3 For connection of indoor-outdoor F1-F2 transmission wiring, and outdoor-outdoor F1-F2 transmission wiring, refer to the service manual.

### Position in switch box

English	Translation
Position in switch box	Position in switch box

### Legend

A1P	Main PCB
A2P	Noise filter PCB
A3P	Inverter PCB
A4P	SUB PCB

A8P	Adapter PCB
A9P	* Cool/heat selector PCB
BS* (A1P)	Push buttons (mode, set, return)
C* (A3P)	Capacitor
DS* (A1P)	DIP switch
E1HC	Crankcase heater
F1S (A2P)	Surge arrestor
F1U (A4P)	Fuse (T, 3.15 A, 250 V)
F401U (A2P)	Fuse (T, 6.3 A, 250 V)
F402U (A2P)	Fuse (T, 6.3 A, 250 V)
F403U (A2P)	Fuse (T, 6.3 A, 250 V)
F410U (A2P)	Fuse (T, 6.3 A, 600 V)
F411U (A2P)	Fuse (T, 6.3 A, 600 V)
F412U (A2P)	Fuse (T, 6.3 A, 600 V)
F*U (A1P)	Fuse (T, 3.15 A, 250 V)
HAP (A1P)	Running LED (service monitor – green)
K1M (A3P)	Magnetic contactor
K*R (A*P)	Magnetic relay
L*R	Reactor
M1C	Motor (compressor)
M*F	Motor (fan)
PS (A1P)	Power supply
Q1DI	# Earth leakage circuit breaker
Q1RP (A1P)	Phase reversal detect circuit
R* (A3P)	Resistor
R*T	Thermistor
R*V (A2P)	Varistor
S1NPH	High pressure sensor
S1NPL	Low pressure sensor
S1PH	High pressure switch (discharge)
S1S	Air control switch
S2S	Cool/heat switch
S3S	Interlock switch
SEG* (A1P)	7-segment display
T1A	Leakage current detection sensor
V1R (A3P)	IGBT power module
V2R (A3P)	Diode module
X66A	Connector (remote switching cool/heat selector)
X*A	PCB connector
X*M	Terminal strip
X*M (A*P)	Terminal strip on PCB
X*Y	Connector
Y*E	Electronic expansion valve
Y*S	Solenoid valve
Z*C	Noise filter (ferrite core)
Z*F	Noise filter
	* Optional
	# Field supply

## For the user

### 13 About the system

The indoor unit part of VRV IV heat recovery system can be used for heating/cooling applications. The type of indoor unit which can be used depends on the outdoor units series.

**NOTICE**

For future modifications or expansions of your system:

A full overview of allowable combinations (for future system extensions) is available in technical engineering data and should be consulted. Contact your installer to receive more information and professional advice.

#### 13.1 System layout

##### Heat pump system

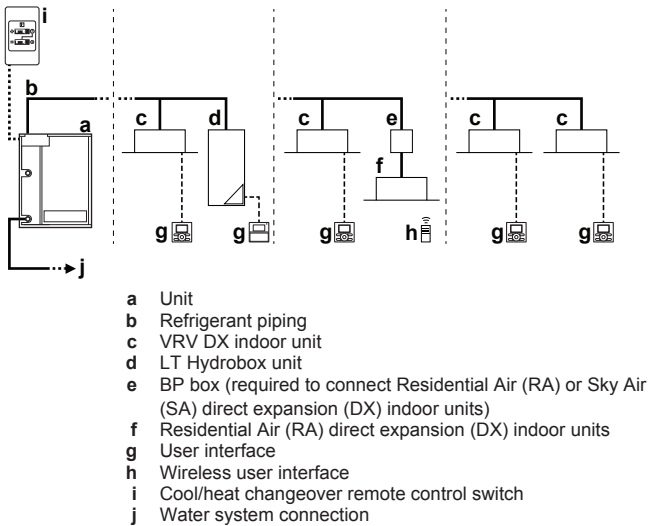

##### Heat recovery system

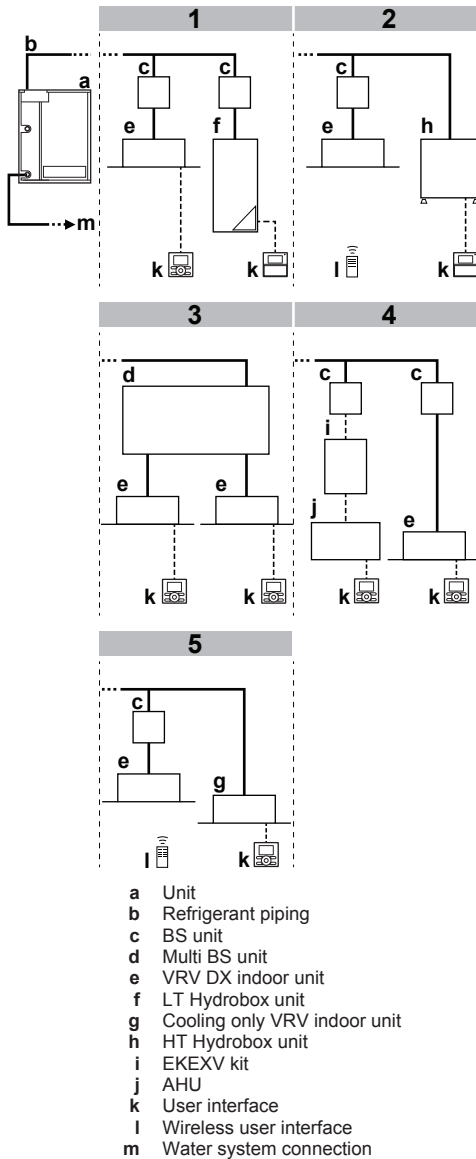

##### Water system

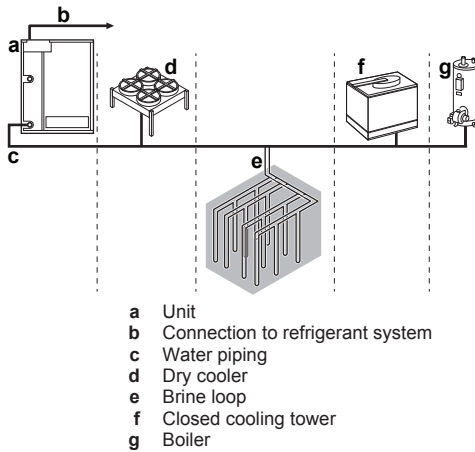

## 14 User interface



### CAUTION

- NEVER touch the internal parts of the controller.
- Do NOT remove the front panel. Some parts inside are dangerous to touch and appliance problems may happen. For checking and adjusting the internal parts, contact your dealer.

This operation manual will give a non-exhaustive overview of the main functions of the system.

Detailed information on required actions to achieve certain functions can be found in the dedicated installation and operation manual of the indoor unit.

Refer to the operation manual of the installed user interface.

## 15 Before operation



### WARNING

This unit contains electrical and hot parts.



### WARNING

Before operating the unit, be sure the installation has been carried out correctly by an installer.



### NOTICE

Never inspect or service the unit by yourself. Ask a qualified service person to perform this work.



### CAUTION

It is not good for your health to expose your body to the air flow for a long time.



### CAUTION

To avoid oxygen deficiency, ventilate the room sufficiently if equipment with burner is used together with the system.



### CAUTION

Do NOT operate the system when using a room fumigation-type insecticide. Chemicals could collect in the unit, and endanger the health of people who are hypersensitive to chemicals.



### NOTICE

Be sure to turn on the power 6 hours before operation in order to have power running to the crankcase heater and to protect the compressor.

This operation manual is for the following systems with standard control. Before initiating operation, contact your dealer for the operation that corresponds to your system type and mark. If your installation has a customised control system, ask your dealer for the operation that corresponds to your system.

Operation modes (depending on indoor unit type):

- Heating and cooling (air to air).
- Fan only operation (air to air).
- Heating and cooling (air to water).
- Domestic hot water operation

Dedicated functions exist depending on the type of indoor unit, refer to dedicated installation/operation manual for more information.

## 16 Operation

### 16.1 Operation range

Use the system in the following temperature and humidity ranges for safe and effective operation.

Above operation range is only valid in case direct expansion indoor units are connected to the VRV IV system.

Special operation ranges are valid in case of using Hydrobox units or AHU. They can be found in the installation/operation manual of the dedicated unit. Latest information can be found in the technical engineering data.

### 16.2 Operating the system

#### 16.2.1 About operating the system

- Operation procedure varies according to the combination of outdoor unit and user interface.
- To protect the unit, turn on the main power switch 6 hours before operation.

#### 16.2.2 About cooling, heating, fan only, and automatic operation

- Changeover cannot be made with a user interface whose display shows "change-over under centralised control" (refer to installation and operation manual of the user interface).
- When the display "change-over under centralised control" flashes, refer to ["16.5.1 About setting the master user interface" on page 49](#).
- The fan may keep on running for about 1 minute after the heating operation stops.
- The air flow rate may adjust itself depending on the room temperature or the fan may stop immediately. This is not a malfunction.

#### 16.2.3 About the heating operation

It may take longer to reach the set temperature for general heating operation than for cooling operation.

The following operation is performed in order to prevent the heating capacity from dropping or cold air from blowing.

##### Defrost operation

In heating operation, freezing of the outdoor unit's air cooled coil increases over time, restricting the energy transfer to the outdoor unit's coil. Heating capability decreases and the system needs to go into defrost operation to be able to remove frost from the outdoor unit's coil. During defrost operation the heating capacity on the indoor unit side will temporarily drop until defrosting is completed. After defrosting, the unit will regain its full heating capacity.

In case of	Then
RWEYQ16~42 multi-models	The indoor unit will continue heating operation at a reduced level during defrost operation. It will guarantee a decent comfort level indoor.
RWEYQ8~14 single models	The indoor unit will stop fan operation, the refrigerant cycle will reverse and energy from inside the building will be used to defrost the outdoor unit coil.

The indoor unit will indicate defrost operation on the display .

# 16 Operation

## Hot start

In order to prevent cold air from blowing out of an indoor unit at the start of heating operation, the indoor fan is automatically stopped. The display of the user interface shows . It may take some time before the fan starts. This is not a malfunction.

### INFORMATION

- The heating capacity drops when the outside temperature falls. If this happens, use another heating device together with the unit. (When using together with appliances that produce open fire, ventilate the room constantly). Do not place appliances that produce open fire in places exposed to the air flow from the unit or under the unit.
- It takes some time to heat up the room from the time the unit is started since the unit uses a hot-air circulating system to heat the entire room.
- If the hot air rises to the ceiling, leaving the area above the floor cold, we recommend that you use the circulator (the indoor fan for circulating air). Contact your dealer for details.

## 16.2.4 To operate the system (WITHOUT cool/heat changeover remote control switch)

- 1 Press the operation mode selector button on the user interface several times and select the operation mode of your choice.

- Cooling operation
- Heating operation
- Fan only operation

- 2 Press the ON/OFF button on the user interface.

**Result:** The operation lamp lights up and the system starts operating.

## 16.2.5 To operate the system (WITH cool/heat changeover remote control switch)

### Overview of the changeover remote control switch

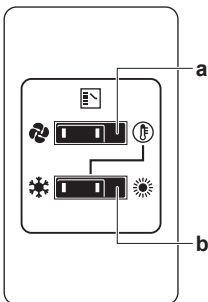

- FAN ONLY/AIR CONDITIONING SELECTOR SWITCH**  
Set the switch to for fan only operation or to for heating or cooling operation.
- COOL/HEAT CHANGEOVER SWITCH**  
Set the switch to for cooling or to for heating

### To start

- 1 Select operation mode with the cool/heat changeover switch as follows:

Cooling operation      Heating operation      Fan only operation

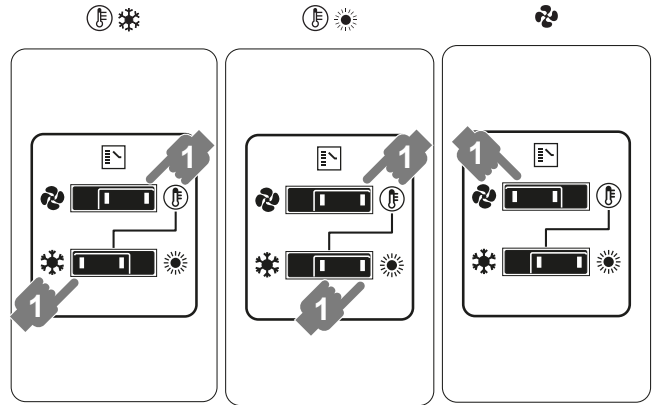

- 2 Press the ON/OFF button on the user interface.

**Result:** The operation lamp lights up and the system starts operating.

### To stop

- 3 Press the ON/OFF button on the user interface once again.

**Result:** The operation lamp goes out and the system stops operating.

### NOTICE

Do not turn off power immediately after the unit stops, but wait for at least 5 minutes.

### To adjust

For programming temperature, fan speed and air flow direction refer to the operation manual of the user interface.

## 16.3 Using the dry program

### 16.3.1 About the dry program

- The function of this program is to decrease the humidity in your room with minimal temperature decrease (minimal room cooling).
- The micro computer automatically determines temperature and fan speed (cannot be set by the user interface).
- The system does not go into operation if the room temperature is low (<20°C).

### 16.3.2 To use the dry program (WITHOUT cool/heat changeover remote control switch)

#### To start

- 1 Press the operation mode selector button on the user interface several times and select (program dry operation).

- 2 Press the ON/OFF button of the user interface.

**Result:** The operation lamp lights up and the system starts operating.

- 3 Press the air flow direction adjust button (only for double-flow, multi-flow, corner, ceiling-suspended and wall-mounted). Refer to "16.4 Adjusting the air flow direction" on page 49 for details.

#### To stop

- 4 Press the ON/OFF button on the user interface once again.

**Result:** The operation lamp goes out and the system stops operating.

### NOTICE

Do not turn off power immediately after the unit stops, but wait for at least 5 minutes.



## 16.3.3 To use the dry program (WITH cool/heat changeover remote control switch)

### To start

- 1 Select cooling operation mode with the cool/heat changeover remote control switch.

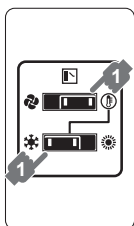

- 2 Press the operation mode selector button on the user interface several times and select (program dry operation).
- 3 Press the ON/OFF button of the user interface.  
**Result:** The operation lamp lights up and the system starts operating.
- 4 Press the air flow direction adjust button (only for double-flow, multi-flow, corner, ceiling-suspended and wall-mounted). Refer to "16.4 Adjusting the air flow direction" on page 49 for details.

### To stop

- 5 Press the ON/OFF button on the user interface once again.

**Result:** The operation lamp goes out and the system stops operating.



### NOTICE

Do not turn off power immediately after the unit stops, but wait for at least 5 minutes.

## 16.4 Adjusting the air flow direction

Refer to the operation manual of the user interface.

### 16.4.1 About the air flow flap

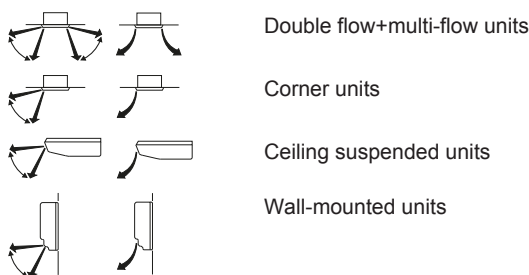

For the following conditions, a micro computer controls the air flow direction which may be different from the display.

The air flow direction can be adjusted in one of the following ways:

- The air flow flap itself adjusts its position.
- The air flow direction can be fixed by the user.
- Automatic and desired position .



### WARNING

Never touch the air outlet or the horizontal blades while the swing flap is in operation. Fingers may become caught or the unit may break down.



### NOTICE

- The movable limit of the flap is changeable. Contact your dealer for details. (only for double-flow, multi-flow, corner, ceiling-suspended and wall-mounted).
- Avoid operating in the horizontal direction . It may cause dew or dust to settle on the ceiling or flap.

## 16.5 Setting the master user interface

### 16.5.1 About setting the master user interface

The displays of slave user interfaces show (change-over under centralised control) and slave user interfaces automatically follow the operation mode directed by the master user interface.

Only the master user interface can select heating or cooling mode.

### 16.5.2 To designate the master user interface (VRV DX and Hydrobox)

- 1 Press the operation mode selector button of the current master user interface for 4 seconds. In case this procedure was not yet performed, the procedure can be executed on the first user interface operated.

**Result:** The display showing (change-over under centralised control) of all slave user interfaces connected to the same outdoor unit flashes.

- 2 Press the operation mode selector button of the controller that you wish to designate as the master user interface.

**Result:** Designation is completed. This user interface is designated as the master user interface and the display showing (change-over under centralised control) vanishes. The displays of other user interfaces show (change-over under centralised control).

## 16.6 About control systems

This system provides two other control systems beside individual control system (one user interface controls one indoor unit). Confirm the following if your unit is of the following control system type:

Type	Description
Group control system	1 user interface controls up to 16 indoor units. All indoor units are equally set.
2 user interface control system	2 user interfaces control 1 indoor unit (in case of group control system, 1 group of indoor units). The unit is individually operated.



### NOTICE

Contact your dealer in case of changing the combination or setting of group control and 2 user interface control systems.

# 17 Energy saving and optimum operation

Observe the following precautions to ensure the system operates properly.

- Adjust the air outlet properly and avoid direct air flow to room inhabitants.
- Adjust the room temperature properly for a comfortable environment. Avoid excessive heating or cooling.
- Prevent direct sunlight from entering a room during cooling operation by using curtains or blinds.

## 18 Maintenance and service

- Ventilate often. Extended use requires special attention to ventilation.
- Keep doors and windows closed. If the doors and windows remain open, air will flow out of your room causing a decrease in the cooling or heating effect.
- Be careful NOT to cool or heat too much. To save energy, keep the temperature setting at a moderate level.
- NEVER place objects near the air inlet or the air outlet of the unit. Doing so may cause a reduced heating/cooling effect or stop operation.
- Turn off the main power supply switch to the unit when the unit is not used for longer periods of time. If the switch is on, it consumes electricity. Before restarting the unit, turn on the main power supply switch 6 hours before operation to ensure smooth running. (Refer to "Maintenance" in the indoor unit manual.)
- When the display shows  (time to clean the air filter), ask a qualified service person to clean the filters. (Refer to "Maintenance" in the indoor unit manual.)
- Keep the indoor unit and user interface at least 1 m away from televisions, radios, stereos, and other similar equipment. Failing to do so may cause static or distorted pictures.
- Do NOT place items under the indoor unit, as they may be damaged by water.
- Condensation may form if the humidity is above 80% or if the drain outlet gets blocked.

This VRV IV heat recovery system is equipped with advanced energy saving functionality. Depending on the priority, emphasises can be put on energy saving or comfort level. Several parameters can be selected, resulting in the optimal balance between energy consumption and comfort for the particular application.

Several patterns are available and roughly explained below. Contact your installer or dealer for advice or to modify the parameters to the needs of your building.

Detailed information is given for the installer in the installation manual. He can help you to realize the best balance between energy consumption and comfort.

### 17.1 Available main operation methods

#### Basic

The refrigerant temperature is fixed independent from the situation. It corresponds to the standard operation which is known and can be expected from/under previous VRV systems.

#### Automatic

The refrigerant temperature is set depending on the outdoor ambient conditions. As such adjusting the refrigerant temperature to match the required load (which is also related to the outdoor ambient conditions).

E.g., when your system is operating in cooling, you do not need as much cooling under low outdoor ambient temperatures (e.g., 25°C) as under high outdoor ambient temperatures (e.g., 35°C). Using this idea, the system automatically starts increasing its refrigerant temperature, automatically reducing the delivered capacity and increasing the system's efficiency.

#### Hi-sensible/economic (cooling/heating)

The refrigerant temperature is set higher/lower (cooling/heating) compared to basic operation. The focus under high sensible mode is comfort feeling for the customer.

The selection method of indoor units is important and has to be considered as the available capacity is not the same as under basic operation.

For details concerning to Hi-sensible applications, please contact your installer.

### 17.2 Available comfort settings

For each of above modes a comfort level can be selected. The comfort level is related to the timing and the effort (energy consumption) which is put in achieving a certain room temperature by temporarily changing the refrigerant temperature to different values in order to achieve requested conditions more quickly.

- Powerful
- Quick
- Mild
- Eco



#### INFORMATION

Combinations of Automatic mode together with Hydrobox applications should be considered. The effect of the energy saving function can be very small when low/high (cooling/heating) leaving water temperatures are requested.

## 18 Maintenance and service



#### NOTICE

Never inspect or service the unit by yourself. Ask a qualified service person to perform this work.



#### WARNING

Never replace a fuse with a fuse of a wrong ampere ratings or other wires when a fuse blows out. Use of wire or copper wire may cause the unit to break down or cause a fire.



#### CAUTION

Do NOT insert fingers, rods or other objects into the air inlet or outlet. Do NOT remove the fan guard. When the fan is rotating at high speed, it will cause injury.



#### CAUTION: Pay attention to the fan!

It is dangerous to inspect the unit while the fan is running.

Be sure to turn off the main switch before executing any maintenance task.



#### CAUTION

After a long use, check the unit stand and fitting for damage. If damaged, the unit may fall and result in injury.



#### NOTICE

Do not wipe the controller operation panel with benzine, thinner, chemical dust cloth, etc. The panel may get discoloured or the coating peeled off. If it is heavily dirty, soak a cloth in water-diluted neutral detergent, squeeze it well and wipe the panel clean. Wipe it with another dry cloth.

### 18.1 Maintenance after a long stop period

E.g., at the beginning of the season.

- Check and remove everything that might be blocking inlet and outlet vents of indoor units and outdoor units.
- Clean air filters and casings of indoor units. Contact your installer or maintenance person to clean air filters and casings of the indoor unit. Maintenance tips and procedures for cleaning are provided in the installation/operation manuals of dedicated indoor units. Make sure to install cleaned air filters back in the same position.

- Turn on the power at least 6 hours before operating the unit in order to ensure smoother operation. As soon as the power is turned on, the user interface display appears.

## 18.2 Maintenance before a long stop period

E.g., at the end of the season.

- Let the indoor units run in fan only operation for about half a day in order to dry the interior of the units. Refer to "16.2.2 About cooling, heating, fan only, and automatic operation" on page 47 for details on fan only operation.
- Turn off the power. The user interface display disappears.
- Clean air filters and casings of indoor units. Contact your installer or maintenance person to clean air filters and casings of the indoor unit. Maintenance tips and procedures for cleaning are provided in the installation/operation manuals of dedicated indoor units. Make sure to install cleaned air filters back in the same position.

## 18.3 About the refrigerant

This product contains fluorinated greenhouse gases. Do NOT vent gases into the atmosphere.

Refrigerant type: R410A

Global warming potential (GWP) value: 2087.5



### NOTICE

In Europe, the **greenhouse gas emissions** of the total refrigerant charge in the system (expressed as tonnes CO<sub>2</sub> equivalent) is used to determine the maintenance intervals. Follow the applicable legislation.

**Formula to calculate the greenhouse gas emissions:**  
GWP value of the refrigerant × Total refrigerant charge [in kg] / 1000

Please contact your installer for more information.



### WARNING

The refrigerant in the system is safe and normally does not leak. If the refrigerant leaks in the room, contact with a fire of a burner, a heater or a cooker may result in a harmful gas.

Turn off any combustible heating devices, ventilate the room and contact the dealer where you purchased the unit.

Do not use the system until a service person confirms that the portion where the refrigerant leaks is repaired.

## 18.4 After-sales service and warranty

### 18.4.1 Warranty period

- This product includes a warranty card that was filled in by the dealer at the time of installation. The completed card has to be checked by the customer and stored carefully.
- If repairs to the product are necessary within the warranty period, contact your dealer and keep the warranty card at hand.

### 18.4.2 Recommended maintenance and inspection

Since dust collects when using the unit for several years, performance of the unit will deteriorate to some extent. As taking apart and cleaning interiors of units requires technical expertise and in order to ensure the best possible maintenance of your units, we recommend to enter into a maintenance and inspection contract on

top of normal maintenance activities. Our network of dealers has access to a permanent stock of essential components in order to keep your unit in operation as long as possible. Contact your dealer for more information.

**When asking your dealer for an intervention, always state:**

- The complete model name of the unit.
- The manufacturing number (stated on the nameplate of the unit).
- The installation date.
- The symptoms or malfunction, and details of the defect.



### WARNING

- Do not modify, disassemble, remove, reinstall or repair the unit yourself as incorrect dismantling or installation may cause an electric shock or fire. Contact your dealer.
- In case of accidental refrigerant leaks, make sure there are no naked flames. The refrigerant itself is entirely safe, non-toxic and non-combustible, but it will generate toxic gas when it accidentally leaks into a room where combustible air from fan heaters, gas cookers, etc. is present. Always have qualified service personnel confirm that the point of leakage has been repaired or corrected before resuming operation.

### 18.4.3 Recommended maintenance and inspection cycles

Be aware that the mentioned maintenance and replacement cycles do not relate to the warranty period of the components.

Component	Inspection cycle	Maintenance cycle (replacements and/or repairs)
Electric motor	1 year	20,000 hours
PCB		25,000 hours
Heat exchanger		5 years
Sensor (thermistor, etc.)		5 years
User interface and switches		25,000 hours
Drain pan		8 years
Expansion valve		20,000 hours
Solenoid valve		20,000 hours

The table assumes the following conditions of use:

- Normal use without frequent starting and stopping of the unit. Depending on the model, we recommend not starting and stopping the machine more than 6 times/hour.
- Operation of the unit is assumed to be 10 hours/day and 2,500 hours/year.



### NOTICE

- The table indicates main components. Refer to your maintenance and inspection contract for more details.
- The table indicates recommended intervals of maintenance cycles. However, in order to keep the unit operational as long as possible, maintenance work may be required sooner. Recommended intervals can be used for appropriate maintenance design in terms of budgeting maintenance and inspection fees. Depending on the content of the maintenance and inspection contract, inspection and maintenance cycles may in reality be shorter than listed.

# 19 Troubleshooting

## 18.4.4 Shortened maintenance and replacement cycles

Shortening of "maintenance cycle" and "replacement cycle" needs to be considered in following situations:

The unit is used in locations where:

- Heat and humidity fluctuate out of the ordinary.
- Power fluctuation is high (voltage, frequency, wave distortion, etc.) (the unit cannot be used if power fluctuation is outside the allowable range).
- Bumps and vibrations are frequent.
- Dust, salt, harmful gas or oil mist such as sulphurous acid and hydrogen sulfide may be present in the air.
- The machine is started and stopped frequently or operation time is long (sites with 24 hour air-conditioning).

Recommended replacement cycle of wear parts

Component	Inspection cycle	Maintenance cycle (replacements and/or repairs)
Air filter	1 year	5 years
High efficiency filter		1 year
Fuse		10 years
Crankcase heater		8 years
Pressure containing parts		In case of corrosion, contact your local dealer.



### NOTICE

- The table indicates main components. Refer to your maintenance and inspection contract for more details.
- The table indicates recommended intervals of replacement cycles. However, in order to keep the unit operational as long as possible, maintenance work may be required sooner. Recommended intervals can be used for appropriate maintenance design in terms of budgeting maintenance and inspection fees. Contact your dealer for details.



### INFORMATION

Damage due to taking apart or cleaning interiors of units by anyone other than our authorised dealers may not be included in the warranty.

# 19 Troubleshooting

If one of the following malfunctions occur, take the measures shown below and contact your dealer.



### WARNING

**Stop operation and shut off the power if anything unusual occurs (burning smells etc.).**

Leaving the unit running under such circumstances may cause breakage, electric shock or fire. Contact your dealer.

The system MUST be repaired by a qualified service person.

If the system does NOT properly operate except for the above mentioned cases and none of the above mentioned malfunctions is evident, investigate the system according to the following procedures.

Malfunction	Measure
If the system does not operate at all.	<ul style="list-style-type: none"> <li>• Check if there is no power failure. Wait until power is restored. If power failure occurs during operation, the system automatically restarts immediately after power is restored.</li> <li>• Check if no fuse has blown or breaker is activated. Change the fuse or reset the breaker if necessary.</li> </ul>
If the system goes into fan only operation, but as soon as it goes into heating or cooling operation, the system stops.	<ul style="list-style-type: none"> <li>• Check if air inlet or outlet of outdoor or indoor unit is not blocked by obstacles. Remove any obstacles and make sure the air can flow freely.</li> <li>• Check if the user interface display shows  (time to clean the air filter). (Refer to "18 Maintenance and service" on page 50 and "Maintenance" in the indoor unit manual.)</li> </ul>
The system operates but cooling or heating is insufficient.	<ul style="list-style-type: none"> <li>• Check if air inlet or outlet of outdoor or indoor unit is not blocked by obstacles. Remove any obstacles and make sure the air can flow freely.</li> <li>• Check if the air filter is not clogged (refer to "Maintenance" in the indoor unit manual).</li> <li>• Check the temperature setting.</li> <li>• Check the fan speed setting on your user interface.</li> <li>• Check for open doors or windows. Close doors and windows to prevent wind from coming in.</li> <li>• Check if there are too many occupants in the room during cooling operation. Check if the heat source of the room is excessive.</li> <li>• Check if direct sunlight enters the room. Use curtains or blinds.</li> <li>• Check if the air flow angle is proper.</li> </ul>

If after checking all above items, it is impossible to fix the problem yourself, contact your installer and state the symptoms, the complete model name of the unit (with manufacturing number if possible) and the installation date (possibly listed on the warranty card).

## 19.1 Error codes: Overview

In case a malfunction code appears on the indoor unit user interface display, contact your installer and inform the malfunction code, the unit type, and serial number (you can find this information on the nameplate of the unit).

For your reference, a list with malfunction codes is provided. You can, depending on the level of the malfunction code, reset the code by pushing the ON/OFF button. If not, ask your installer for advice.

## 19.2 Symptoms that are NOT system malfunctions

The following symptoms are NOT system malfunctions:



### 19.2.1 Symptom: The system does not operate

- The air conditioner does not start immediately after the ON/OFF button on the user interface is pressed. If the operation lamp lights, the system is in normal condition. To prevent overloading of the compressor motor, the air conditioner starts 5 minutes after it

is turned ON again in case it was turned OFF just before. The same starting delay occurs after the operation mode selector button was used.

- If "Under Centralized Control" is displayed on the user interface, pressing the operation button causes the display to blink for a few seconds. The blinking display indicates that the user interface cannot be used.
- The system does not start immediately after the power supply is turned on. Wait one minute until the micro computer is prepared for operation.

### 19.2.2 Symptom: Cool/Heat cannot be changed over

- When the display shows  (change-over under centralized control), it shows that this is a slave user interface.
- When the cool/heat changeover remote control switch is installed and the display shows , this is because cool/heat changeover is controlled by the cool/ heat changeover remote control switch. Ask your dealer where the remote control switch is installed.

### 19.2.3 Symptom: Fan operation is possible, but cooling and heating do not work

Immediately after the power is turned on. The micro computer is getting ready to operate and is performing a communication check with all indoor units. Please wait 12 minutes maximally until this process is finished.

### 19.2.4 Symptom: The fan speed does not correspond to the setting

The fan speed does not change even if the fan speed adjustment button is pressed. During heating operation, when the room temperature reaches the set temperature, the outdoor unit goes off and the indoor unit changes to whisper fan speed. This is to prevent cold air blowing directly on occupants of the room. The fan speed will not change even when another indoor unit is in heating operation, if the button is pressed.

### 19.2.5 Symptom: The fan direction does not correspond to the setting

The fan direction does not correspond with the user interface display. The fan direction does not swing. This is because the unit is being controlled by the micro computer.

### 19.2.6 Symptom: White mist comes out of a unit (Indoor unit)

- When humidity is high during cooling operation. If the interior of an indoor unit is extremely contaminated, the temperature distribution inside a room becomes uneven. It is necessary to clean the interior of the indoor unit. Ask your dealer for details on cleaning the unit. This operation requires a qualified service person.
- Immediately after the cooling operation stops and if the room temperature and humidity are low. This is because warm refrigerant gas flows back into the indoor unit and generates steam.

### 19.2.7 Symptom: White mist comes out of a unit (Indoor unit, outdoor unit)

When the system is changed over to heating operation after defrost operation. Moisture generated by defrost becomes steam and is exhausted.

### 19.2.8 Symptom: The user interface display reads "U4" or "U5" and stops, but then restarts after a few minutes

This is because the user interface is intercepting noise from electric appliances other than the air conditioner. The noise prevents communication between the units, causing them to stop. Operation automatically restarts when the noise ceases.

### 19.2.9 Symptom: Noise of air conditioners (Indoor unit)

- A "zeen" sound is heard immediately after the power supply is turned on. The electronic expansion valve inside an indoor unit starts working and makes the noise. Its volume will reduce in about one minute.
- A continuous low "shah" sound is heard when the system is in cooling operation or at a stop. When the drain pump (optional accessories) is in operation, this noise is heard.
- A "pishi-pishi" squeaking sound is heard when the system stops after heating operation. Expansion and contraction of plastic parts caused by temperature change make this noise.
- A low "sah", "choro-choro" sound is heard while the indoor unit is stopped. When another indoor unit is in operation, this noise is heard. In order to prevent oil and refrigerant from remaining in the system, a small amount of refrigerant is kept flowing.

### 19.2.10 Symptom: Noise of air conditioners (Indoor unit, outdoor unit)

- A continuous low hissing sound is heard when the system is in cooling or defrost operation. This is the sound of refrigerant gas flowing through both indoor and outdoor units.
- A hissing sound which is heard at the start or immediately after stopping operation or defrost operation. This is the noise of refrigerant caused by flow stop or flow change.

### 19.2.11 Symptom: Noise of air conditioners (Outdoor unit)

When the tone of operating noise changes. This noise is caused by the change of frequency.

### 19.2.12 Symptom: Dust comes out of the unit

When the unit is used for the first time in a long time. This is because dust has gotten into the unit.

### 19.2.13 Symptom: The units can give off odours

The unit can absorb the smell of rooms, furniture, cigarettes, etc., and then emit it again.

### 19.2.14 Symptom: The outdoor unit fan does not spin

During operation. The speed of the fan is controlled in order to optimise product operation.

### 19.2.15 Symptom: The display shows "88"

This is the case immediately after the main power supply switch is turned on and means that the user interface is in normal condition. This continues for 1 minute.

## 20 Relocation

---

### 19.2.16 Symptom: The compressor in the outdoor unit does not stop after a short heating operation

This is to prevent refrigerant from remaining in the compressor. The unit will stop after 5 to 10 minutes.

### 19.2.17 Symptom: The inside of an outdoor unit is warm even when the unit has stopped

This is because the crankcase heater is warming the compressor so that the compressor can start smoothly.

### 19.2.18 Symptom: Hot air can be felt when the indoor unit is stopped

Several different indoor units are being run on the same system. When another unit is running, some refrigerant will still flow through the unit.

### Maintenance instructions

Instruction manual specified for a certain product or application, which explains (if relevant) how to install, configure, operate and/or maintain the product or application.

### Accessories

Labels, manuals, information sheets and equipment that are delivered with the product and that need to be installed according to the instructions in the accompanying documentation.

### Optional equipment

Equipment made or approved by Daikin that can be combined with the product according to the instructions in the accompanying documentation.

### Field supply

Equipment NOT made by Daikin that can be combined with the product according to the instructions in the accompanying documentation.

## 20 Relocation

Contact your dealer for removing and reinstalling the total unit. Moving units requires technical expertise.

## 21 Disposal

This unit uses hydrofluorocarbon. Contact your dealer when discarding this unit.



### NOTICE

Do NOT try to dismantle the system yourself: dismantling of the system, treatment of the refrigerant, oil and other parts MUST comply with applicable legislation. Units MUST be treated at a specialised treatment facility for reuse, recycling and recovery.

---

## 22 Glossary

### Dealer

Sales distributor for the product.

### Authorized installer

Technical skilled person who is qualified to install the product.

### User

Person who is owner of the product and/or operates the product.

### Applicable legislation

All international, European, national and local directives, laws, regulations and/or codes that are relevant and applicable for a certain product or domain.

### Service company

Qualified company which can perform or coordinate the required service to the product.

### Installation manual

Instruction manual specified for a certain product or application, explaining how to install, configure and maintain it.

### Operation manual

Instruction manual specified for a certain product or application, explaining how to operate it.

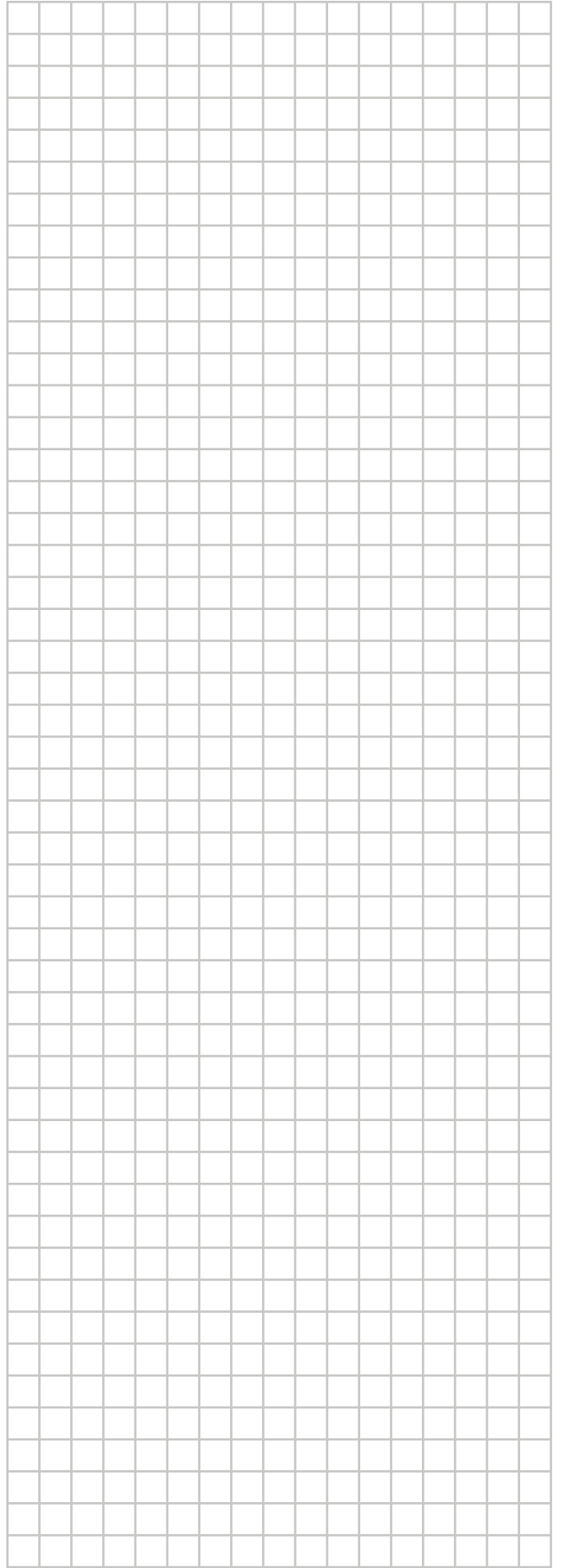
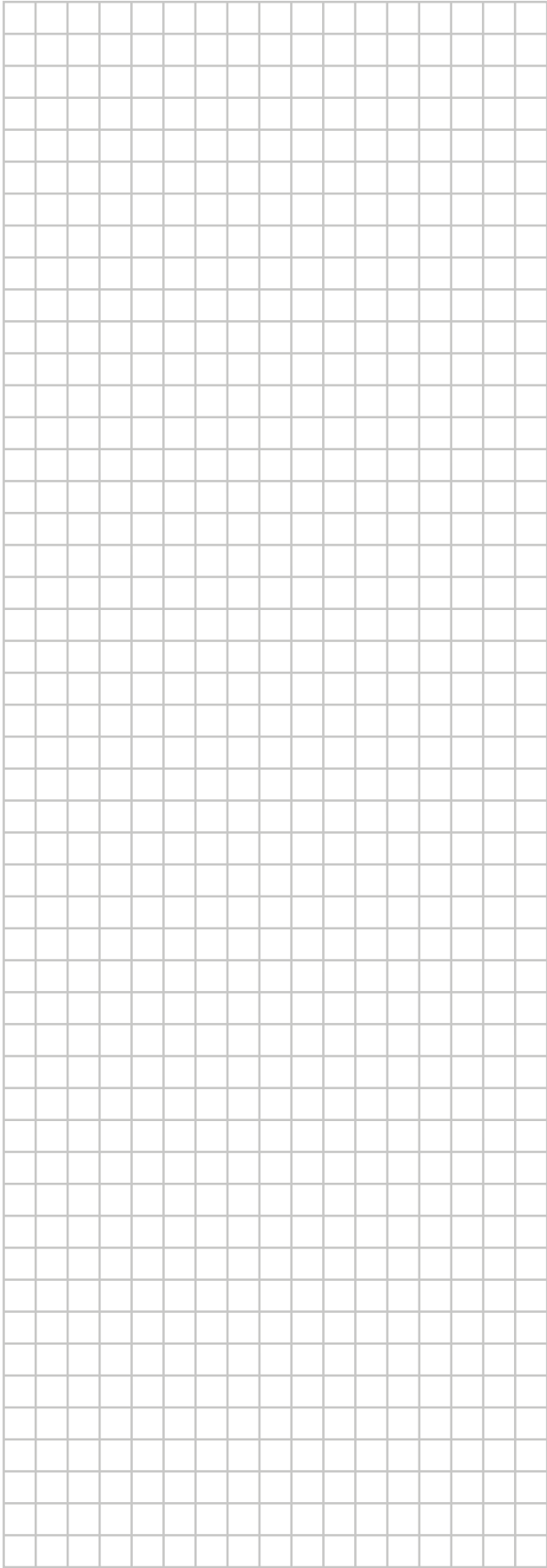

ERC

Copyright 2017 Daikin