

---

User's Guide

# PrecisionTree

## *Decision Analysis Add-In For Microsoft® Excel*

October, 2004

---

Palisade Corporation  
31 Decker Road  
Newfield, NY 14867  
(607) 277-8000  
<http://www.palisade.com>

---

## **Copyright Notice**

Copyright © 1996-2004, Palisade Corporation

## **Trademark Acknowledgments**

PrecisionTree, TopRank, BestFit and Palisade are registered trademarks of Palisade Corporation.

RISK is a trademark of Parker Brothers, Division of Tonka Corporation, and is used under license.

Microsoft, Excel and Windows are registered trademarks of Microsoft Corporation.

---

# Welcome

Welcome to PrecisionTree, the decision analysis software that's an add-in to Microsoft Excel. Now you can do something you've never been able to do before - define a decision tree or influence diagram directly in your spreadsheet. PrecisionTree allows you to run a complete decision analysis without leaving the program where your data is - your spreadsheet!

## Why You Need Decision Analysis and PrecisionTree

You might wonder if the decisions you make are suitable for decision analysis. If you are looking for a way to structure your decisions to make them more organized and easier to explain to others, you definitely should consider using formal decision analysis.

When faced with a complex decision, decision makers must be able to organize the problem efficiently. They have to consider all possible options by analyzing all available information. In addition, they need to present this information to others in a clear, concise format. PrecisionTree allows decision makers to do all this, and more!

But, what exactly does decision analysis allow you to do? As the decision maker, you can clarify options and rewards, describe uncertainty quantitatively, weigh multiple objectives simultaneously and define risk preferences. All in an Excel spreadsheet.

### Modeling Features

#### *PrecisionTree and Microsoft Excel*

As an "add-in" to Microsoft Excel, PrecisionTree "links" directly to Excel to add Decision Analysis capabilities. The PrecisionTree system provides all the necessary tools for setting up and analyzing decision trees and influence diagrams. And PrecisionTree works in a style you are familiar with — Excel-style menus and toolbars.

With PrecisionTree, there's no limit to the size tree you can define. Design a tree which spans multiple worksheets in an Excel workbook! PrecisionTree reduces the tree to an easy-to-understand report right in your current workbook.

**PrecisionTree  
Nodes**

PrecisionTree allows you to define influence diagram and decision tree nodes in Excel spreadsheets. Node types offered by PrecisionTree include:

- ◆ *Chance nodes*
- ◆ *Decision nodes*
- ◆ *End nodes*
- ◆ *Logic nodes*
- ◆ *Reference nodes*

Values and probabilities for nodes are placed directly in spreadsheet cells, allowing you to easily enter and edit the definition of your decision models.

**Model Types**

PrecisionTree creates both decision trees and influence diagrams. Influence diagrams are excellent for showing the relationship between events and the general structure of a decision clearly and concisely, while decision trees outline the chronological and numerical details of the decision.

**Values in  
Models**

In PrecisionTree, all decision model values and probabilities are entered directly in spreadsheet cells, just like other Excel models. PrecisionTree can also link values in a decision model directly to locations you specify in a spreadsheet model. The results of that model are then used as the payoffs for each path through the decision tree.

All calculations of payoffs happen in “real-time” – that is, as you edit your tree, all payoffs and node values are automatically recalculated.

**Decision  
Analysis**

PrecisionTree's decision analyses give you straightforward reports including statistical reports, risk profiles and policy suggestions\* (\*PrecisionTree Pro only). And, decision analysis can produce more qualitative results by helping you understand tradeoffs, conflicts of interest, and important objectives.

All analysis results are reported directly in Excel for easy customization, printing and saving. There's no need to learn a whole new set of formatting commands since all PrecisionTree reports can be modified like any other Excel worksheet or chart.

<b>Sensitivity Analysis</b>	<p>Have you ever wondered which variables matter most in your decision? If so, you need PrecisionTree's sensitivity analysis options. Perform both one and two-way sensitivity analyses and generate Tornado Graphs, spider graphs, strategy region graphs (PrecisionTree Pro only), and more!</p> <p>For those who need more sophisticated sensitivity analyses, PrecisionTree links directly to TopRank, Palisade Corporation's sensitivity analysis add-in.</p>
<b>Reducing a Tree</b>	<p>Because decision trees can expand as more possible decision options are added, PrecisionTree offers a set of features designed to help you reduce trees to a more manageable size. All nodes can be collapsed, hiding all paths which follow the node from view. A single subtree can be referenced from multiple nodes in other trees, saving the re-entry of the same tree over and over.</p>
<b>Risk Analysis</b>	<p>@RISK, Palisade Corporation's risk analysis add-in, is a perfect companion to PrecisionTree. @RISK allows you to quantify the uncertainty in any spreadsheet model using distribution functions. Then, at the click of a button, @RISK performs a Monte Carlo simulation of your model, analyzing every possible outcome and graphically illustrating the risks you face.</p> <p>Use @RISK to define uncertain (chance) events in your model as continuous distributions instead of estimating outcomes in a finite number of branches. Probability distributions can be applied to any uncertain value or probability in your decision trees and supporting spreadsheets. With this information, @RISK can run a complete Monte Carlo simulation of your decision tree, showing you the range of possible results that could occur.</p>
<b>Advanced Analysis Capabilities</b>	<p>PrecisionTree offers many advanced analysis options including:</p> <ul style="list-style-type: none"> <li>◆ <i>Utility functions</i></li> <li>◆ <i>Use of multiple worksheets to define trees</i></li> <li>◆ <i>Logic nodes</i></li> </ul>



---

# Table of Contents

<b>Chapter 1: Getting Started</b> .....	<b>1</b>
<b>Introduction</b> .....	<b>3</b>
<b>Installation Instructions</b> .....	<b>7</b>
<b>Using PrecisionTree</b> .....	<b>11</b>
<b>Chapter 2: Overview of Decision Analysis</b> .....	<b>13</b>
<b>Introduction</b> .....	<b>15</b>
<b>Influence Diagrams</b> .....	<b>17</b>
<b>Decision Trees</b> .....	<b>21</b>
<b>Influence Diagrams vs. Decision Trees</b> .....	<b>25</b>
<b>Analyzing a Model</b> .....	<b>27</b>
<b>Sensitivity Analysis</b> .....	<b>33</b>
<b>Chapter 3: Overview of PrecisionTree</b> .....	<b>39</b>
<b>Introduction</b> .....	<b>41</b>
<b>A Quick Overview to PrecisionTree</b> .....	<b>43</b>
<b>Setting Up a Decision Tree</b> .....	<b>49</b>
<b>Setting Up an Influence Diagram</b> .....	<b>57</b>
<b>Analyzing a Decision Model</b> .....	<b>67</b>
<b>Advanced Features</b> .....	<b>77</b>

<b>Chapter 4: Modeling Techniques.....</b>	<b>81</b>
<b>Introduction .....</b>	<b>83</b>
<b>Attaching a Decision Tree to An Existing Excel Model .....</b>	<b>85</b>
<b>Generating Branch and End Node Payoffs with Formulas .....</b>	<b>89</b>
<b>Conducting a Sensitivity Analysis on Probabilities.....</b>	<b>91</b>
<b>Chapter 5: PrecisionTree Command Reference.....</b>	<b>93</b>
<b>Introduction .....</b>	<b>95</b>
<b>PrecisionTree Toolbar Icons .....</b>	<b>97</b>
<b>PrecisionTree Menu .....</b>	<b>99</b>
<b>Create New Submenu - Tree Command.....</b>	<b>100</b>
<b>Create New Submenu - Influence Diagram or Node Command.....</b>	<b>101</b>
<b>Create New Influence Arc Icon.....</b>	<b>102</b>
<b>Settings Command.....</b>	<b>103</b>
<b>Settings Command - Decision Tree Option .....</b>	<b>104</b>
<b>Settings Command - Decision Tree Node Option .....</b>	<b>110</b>
<b>Settings Command - Decision Tree Branch Option.....</b>	<b>117</b>
<b>Settings Command - Influence Diagram Option .....</b>	<b>118</b>
<b>Settings Command - Influence Diagram Node Option .....</b>	<b>120</b>
<b>Settings Command - Influence Diagram Arc Option.....</b>	<b>123</b>
<b>Decision Analysis Command .....</b>	<b>126</b>
<b>Sensitivity Analysis Command .....</b>	<b>129</b>
<b>Graph Options Command.....</b>	<b>136</b>
<b>Zoom Selection Command.....</b>	<b>137</b>



Update Links Command.....	137
Contents Command.....	138
Authorization Command .....	138
About Command .....	138
<b>Chapter 6: Distribution and Simulation Function Reference .....</b>	<b>139</b>
Introduction .....	141
Table of Available Functions .....	149
<b>Appendix A: Bayes' Theorem .....</b>	<b>155</b>
Introduction .....	157
Derivation of Bayes' Theorem .....	159
Using Bayes' Theorem .....	161
<b>Appendix B: Utility Functions.....</b>	<b>163</b>
What is Risk? .....	165
Measuring Risk with Utility Functions.....	167
PrecisionTree and Utility Functions .....	169
Custom Utility Functions .....	171
<b>Appendix C: Recommended Readings.....</b>	<b>175</b>
Books and Articles on Decision Analysis .....	175
<b>Appendix D: Using PrecisionTree With Other DecisionTools.....</b>	<b>177</b>
The DecisionTools Suite .....	177
Palisade's DecisionTools Case Study .....	179
Introduction to @RISK .....	183

<b>Using PrecisionTree With @RISK.....</b>	<b>187</b>
<b>Introduction to TopRank .....</b>	<b>191</b>
<b>Using PrecisionTree With TopRank .....</b>	<b>195</b>
<b>Introduction to BestFit.....</b>	<b>197</b>
<b>Using PrecisionTree With BestFit.....</b>	<b>201</b>
<b>Introduction to RISKview .....</b>	<b>203</b>
<b>Using PrecisionTree with RISKview .....</b>	<b>205</b>
<b>Appendix E: Glossary of Terms .....</b>	<b>207</b>
<b>Index .....</b>	<b>215</b>

---

# Chapter 1: Getting Started

<b>Introduction .....</b>	<b>3</b>
Checking Your Package .....	3
Deciding What to Read .....	3
PrecisionTree Pro .....	4
If You Need Help .....	4
Register Now! .....	4
PrecisionTree System Requirements .....	6
<b>Installation Instructions .....</b>	<b>7</b>
General Installation Instructions .....	7
The DecisionTools Suite .....	8
Setting Up the PrecisionTree Icons or Shortcuts .....	9
<b>Using PrecisionTree .....</b>	<b>11</b>
Starting PrecisionTree .....	11
Macro Security Warning Message on Startup .....	11
Exiting PrecisionTree .....	12
Learning to Use PrecisionTree .....	12



# Introduction

This introduction describes the contents of the PrecisionTree package and shows how to install PrecisionTree and attach it to your copy of Microsoft Excel.

## Checking Your Package

Your PrecisionTree package should contain:

### ***The PrecisionTree User's Guide (this book) with:***

- ◆ *Preface and Getting Started*
- ◆ *Overview of Decision Analysis*
- ◆ *Overview of PrecisionTree*
- ◆ *Modeling Techniques*
- ◆ *PrecisionTree Command Reference*
- ◆ *Technical Appendices*

### ***The PrecisionTree CD-ROM including:***

- ◆ *PrecisionTree System Files*
- ◆ *PrecisionTree Example Files*
- ◆ *PrecisionTree Tutorial*

### ***The PrecisionTree Licensing Agreement and User Registration Card***

If your package is not complete, please call your PrecisionTree dealer or supplier or contact Palisade Corporation directly at (607) 277-8000 or (800) 432-7475 (US only).

## Deciding What to Read

If you want to use PrecisionTree right away, you can go directly to the installation instructions at the end of this chapter. If you know about decision analysis but not about PrecisionTree, try working through the on-line tutorial after installing the PrecisionTree system. If you are not familiar with decision analysis, start with the *Overview of Decision Analysis* which follows this chapter. The overview discusses concepts and techniques of decision analysis and gives a good background for proceeding through the tutorial.

Both the *Modeling Techniques* chapter and the *PrecisionTree Command Reference* provide valuable information about your everyday use of PrecisionTree. The *Modeling Techniques* chapter shows you how to model typical decisions you may encounter. Included on the PrecisionTree CD-ROM are examples which illustrate the described

modeling techniques. The *PrecisionTree Command Reference* explains all PrecisionTree toolbar and menu commands.

Use the *Technical Appendices* when you need more information on a topic or concept. For the latest information on your version of PrecisionTree, check your PrecisionTree disks for a README.WRI file. This file contains information about PrecisionTree that may be more current than the information contained in this manual.

***Much of the information in this User's Guide is presented on-line in short lessons started by clicking on the PrecisionTree Tutorial icon in the Taskbar or Program Manager.***

## PrecisionTree Pro

PrecisionTree is available in both standard and professional versions. Features that are available only in PrecisionTree Pro, as well as features that behave differently in the professional version, are marked with a "Pro" symbol in the left margin. An example of this symbol is displayed to the left of this paragraph.

## If You Need Help

Technical support is available for three months to all registered users of PrecisionTree. The availability of customer support after three months is subject to the purchase of a PrecisionTree maintenance agreement, which entitles you to free product upgrades and unlimited telephone support.

If you contact us by telephone, please have your serial number and User's Guide ready. We can offer better technical support if you are in front of your computer and ready to work.

## Register Now!

As a registered user, you'll be notified of upgrades, new products and other important announcements. And only registered users receive technical support on PrecisionTree!

### **Before Calling**

Before contacting technical support, please review the following checklist:

- ◆ *Have you referred to the on-line help? Use the Tech Support command in the Help Menu for answers to common questions and explanations of error codes.*
- ◆ *Have you read the README.WRI file? It contains current information on PrecisionTree that may not be included in the manual.*
- ◆ *Can you duplicate the problem consistently? Can you duplicate the problem on a different computer or with a different model?*

- ◆ *Have you looked at our site on the World Wide Web? It can be found at <http://www.palisade.com>. Our Web site also contains the latest FAQ (a searchable database of tech support questions and answers) and PrecisionTree patches in our Technical Support section. We recommend visiting our Web site regularly for all the latest information on PrecisionTree and other Palisade software.*

**Contacting  
Palisade**

Palisade Corporation welcomes your questions, comments or suggestions regarding PrecisionTree. You may contact our technical support staff using any of the following methods:

- *E-mail us at [tech-support@palisade.com](mailto:tech-support@palisade.com).*
- *Telephone us at (607) 277-8000 any weekday from 9:00 AM to 5:00 PM, EST. Press 2 on a touch-tone phone to reach technical support.*
- *Fax us at (607) 277-8001.*
- *Mail us a letter at:*

**Technical Support  
Palisade Corporation  
31 Decker Road  
Newfield, NY 14867 USA**

If you want to contact Palisade Europe:

- *E-mail us at [tech-support@palisade-europe.com](mailto:tech-support@palisade-europe.com).*
- *Telephone us at +44 (0)207 426 9950 (UK).*
- *Fax us at +44 (0)207 375 1229 (UK).*
- *Mail us a letter at:*

**Palisade Europe  
Technical Support  
The Blue House, Unit 1  
30 Calvin Street  
London E1 6NW UK**

Regardless of how you contact us, please include the product name, version and serial number.

**If You Own a  
Student Version  
of PrecisionTree**

Telephone support is not available with the student version of PrecisionTree. If you need help, we recommend the following alternatives:

- ◆ *Consult with your professor or teaching assistant*
- ◆ *Log-on to our site on the World Wide Web for answers to frequently asked questions*
- ◆ *Contact our technical support department via e-mail or fax*

## **PrecisionTree System Requirements**

System requirements for the Windows version of PrecisionTree include:

- ◆ *A Pentium PC or faster is recommended.*
- ◆ *Microsoft Windows 98 or higher*
- ◆ *16 MB installed memory, 32MB recommended.*
- ◆ *Microsoft Excel Version 97 or higher*



# Installation Instructions

PrecisionTree is an add-in program to Microsoft Excel. By adding additional commands to the Excel menu bars, PrecisionTree enhances the functionality of Excel. Since PrecisionTree requires a hard disk, always use the copy of PrecisionTree you have installed onto the hard disk.

## General Installation Instructions

The Setup program copies the PrecisionTree system files into a directory you specify on your hard disk. Setup asks you for the location of the Excel directory on your hard disk, so please note this information before running Setup. Setup and PrecisionTree require Microsoft Windows to run, so be sure to start Windows before running these programs.

To run the Setup program in Windows 98 or higher:

- 1) *Insert the PrecisionTree CD-ROM in your CD-ROM drive*
- 2) *Click the Start button, click Settings and then click Control Panel*
- 3) *Double-click the Add/Remove Programs icon*
- 4) *On the Install/Uninstall tab, click the Install button*
- 5) *Follow the Setup instructions on the screen*

If you encounter problems while installing *PrecisionTree*, verify that there is adequate space on the drive to which you're trying to install. After you've freed up adequate space, try rerunning the installation.

### **Authorizing Your Copy of PrecisionTree**

Within 30 days of installing PrecisionTree you need to authorize your copy of PrecisionTree. Authorization can be done over the Internet by clicking the **Authorize Now** button in the Authorization dialog that is displayed each time PrecisionTree is started and following the prompts on the screen. Alternatively, you can contact Palisade or Palisade Europe during normal business hours and authorize your copy of PrecisionTree over the phone.

An authorized copy of PrecisionTree is licensed for use on a single computer only. If you wish to move your copy of PrecisionTree to a different computer, please contact Palisade for instructions.

**Removing  
PrecisionTree  
from Your  
Computer**

Setup creates the file INSTALL.LOG in your PrecisionTree directory. This file lists the names and locations of all installed files. If you wish to remove PrecisionTree from your computer when running Windows 98 or higher or Windows NT 4 or higher, use the Control Panel's Add/Remove Programs utility and select the entry for PrecisionTree.

## **The DecisionTools Suite**

PrecisionTree for Excel is a member of the DecisionTools Suite, a set of products for risk and decision analysis described in **Appendix D: Using PrecisionTree With Other DecisionTools**. The default installation procedure of PrecisionTree puts PrecisionTree in a subdirectory of a main "Program Files\Palisade" directory. This is quite similar to how Excel is often installed into a subdirectory of a "Program Files\Microsoft Office" directory.

One subdirectory of the Program Files\Palisade directory will be the PrecisionTree directory (by default called PTREE32). This directory contains the PrecisionTree program files plus example models and other files necessary for PrecisionTree to run. Another subdirectory of Program Files\Palisade is the SYSTEM directory which contains files which are needed by every program in the DecisionTools Suite, including common help files and program libraries.

**The  
DecisionTools  
Toolbar**

When you launch one of the elements of the Suite (such as PrecisionTree) from its desktop icon, Excel will load a "DecisionTools Suite" toolbar which contains one icon for each program of the Suite. This allows you to launch any of the other products in the suite directly from Excel.

***Note: In order for TopRank, the what-if analysis program in the DecisionTools Suite, to work properly with PrecisionTree, you must have release TopRank 1.5e or higher.***

## Setting Up the PrecisionTree Icons or Shortcuts

### ***Creating the Shortcut in the Windows Taskbar***

In Windows, setup automatically creates an PrecisionTree command in the Programs menu of the Taskbar. However, if problems are encountered during Setup, or if you wish to do this manually another time, follow the following directions.

- 1) Click the Start button, and then point to Settings.*
- 2) Click Taskbar, and then click the Start Menu Programs tab.*
- 3) Click Add, and then click Browse.*
- 4) Locate the file PTREE.EXE and double click it.*
- 5) Click Next, and then double-click the menu on which you want the program to appear.*
- 6) Type the name "PrecisionTree", and then click Finish.*



# Using PrecisionTree

## Starting PrecisionTree

The PrecisionTree system is comprised of several files and libraries, all of which are necessary to run the program. The Excel add-in file **PTREE.XLA** starts PrecisionTree within Excel, opening necessary files and initializing libraries.

To use PrecisionTree in a normal Excel session:

- *Click the PrecisionTree icon in the PrecisionTree program group or taskbar folder, starting PrecisionTree and Excel, or*
- *When in Excel, open the file PTREE.XLA using the Excel Tools Addins command. Make sure to change to the PTREE32 subdirectory of the "Program Files\Palisade" directory.*
- *When in Excel, click the PrecisionTree icon on the DecisionTools toolbar.*

## Macro Security Warning Message on Startup

Microsoft Office provides several security settings (under **Tools>Macro>Security**) to keep unwanted or malicious macros from being run in Office applications. A warning message appears each time you attempt to load a file with macros, unless you use the lowest security setting. To keep this message from appearing every time you run a Palisade add-in, Palisade digitally signs their add-in files. Thus, once you have specified **Palisade Corporation** as a trusted source, you can open any Palisade add-in without warning messages. To do this:

- Click **Always trust macros from this source** when a Security Warning dialog (such as the one below) is displayed when starting PrecisionTree.



## Exiting PrecisionTree

To exit PrecisionTree and Excel:

- 1) *Select Quit from the Excel File menu.*

To unload PrecisionTree without ending your Excel session:

- 1) *Select the About command from the Decision Tree menu*
- 2) *Click the Unload PrecisionTree button.*

## Learning to Use PrecisionTree

The PrecisionTree system includes a comprehensive on-line tutorial which gets you started with PrecisionTree by leading you through an analysis of a simple decision model in Microsoft Excel. The overview introduces you to important concepts in PrecisionTree. You'll learn to design an influence diagram and a decision tree using the PrecisionTree custom toolbar and use PrecisionTree to analyze your decision model. The tutorial shows you the types of results a PrecisionTree analysis generates and how to interpret those results in order to make the best decision.

***To view the on-line tutorial, click the icon titled The PrecisionTree Tutorial in the PrecisionTree program.***

---

# Chapter 2: Overview of Decision Analysis

<b>Introduction</b> .....	<b>15</b>
What is Decision Analysis?.....	15
Modeling a Decision.....	16
<b>Influence Diagrams</b> .....	<b>17</b>
Sports Wager Example.....	17
Guidelines for Using Arcs .....	18
Guidelines for Designing Influence Diagrams.....	18
<b>Decision Trees</b> .....	<b>21</b>
Event and Fault Trees.....	22
Guidelines for Designing Trees.....	22
<b>Influence Diagrams vs. Decision Trees</b> .....	<b>25</b>
<b>Analyzing a Model</b> .....	<b>27</b>
Solving Decision Trees .....	27
Constructing Risk Profiles .....	28
Policy Suggestion.....	30
Solving Influence Diagrams .....	31
<b>Sensitivity Analysis</b> .....	<b>33</b>
Definition of Terms.....	33
One-Way Sensitivity Analysis.....	34
One-Way Sensitivity Graphs.....	34
Tornado Graphs .....	35
Spider Graphs.....	36
Two-Way Sensitivity Analysis .....	37
Strategy Region Graphs .....	37





# Introduction

PrecisionTree brings advanced modeling and decision analysis to Microsoft Excel worksheets. You might wonder if the decisions you make are suitable for decision analysis. If you are looking for a way to structure your decisions to make them more organized and easier to explain to others, you definitely should consider using formal decision analysis.

## Modeling With PrecisionTree

Modeling is a catch-all phrase that usually means any type of activity where you are trying to create a representation of a real life situation — so you can analyze it. Your representation, or model, can be used to examine the situation, and hopefully understand what the future might bring. Since you've probably built an Excel spreadsheet, you've built a model! But don't worry, you don't have to be an expert in statistics or decision theory to create a decision model, and you certainly don't have to be an expert to use PrecisionTree. We can't teach you everything in a few pages, but we'll get you started. Once you begin using PrecisionTree you'll automatically begin picking up the type of expertise that can't be learned from a book.

Another purpose of this chapter is to explain how PrecisionTree works with Microsoft Excel to perform decision analyses. You don't have to know how PrecisionTree works to use it successfully, but you might find some explanations useful and interesting.

## What is Decision Analysis?

Decision analysis provides a systematic method for describing problems. It is the process of modeling a problem situation, taking into account the decision maker's preferences and beliefs regarding uncertainty, in order to identify the decision that should be made.

A decision analysis gives you a straightforward report consisting of the preferred decision path and a risk profile of all possible results. Decision analysis can also produce more qualitative results by helping to understand tradeoffs, conflicts of interest, and important objectives.

## **Modeling a Decision**

The first step in decision analysis is defining the problem you wish to solve. Do you want to maximize profit or minimize the impact on the environment? Probably, your goal is a combination of the two. Once you have clarified your goals, you are ready to design a model.

Decisions may be modeled in one of two forms, decision trees and influence diagrams. While decision trees are the traditional tool used in decision analysis, influence diagrams are a recent, and powerful, addition to the decision maker's arsenal. The rest of this chapter provides a thorough explanation of both techniques.

# Influence Diagrams

## Introduction

Influence diagrams present a decision in a simple, graphical form. Decisions, chance events and payoffs (values) are drawn as shapes (called nodes) and are connected by arrows (called arcs) which define their relationship to each other. In this way, a complex decision may be reduced to a few shapes and lines. Influence diagrams are excellent for showing the relationship between events and the general structure of a decision clearly and concisely.

### **Nodes**

In PrecisionTree, decision nodes are drawn as green squares, chance nodes as red circles and payoff nodes as blue diamonds.

### **Arcs**

Arcs point from a predecessor node to a successor node, indicating a dependence between the two nodes. An arc may contain different forms of influence: value, timing or structural or a combination of the three.

## Sports Wager Example

A simple decision to model is one where there is one decision and one chance event affecting the outcome. For example, you may have an opportunity to bet on a sports game. Your decision is whether to bet on Team A or Team B (or not at all). The chance event is the outcome of the game. The payoff node represents the monetary payoff (or loss) of the wager.

### **Influence Diagram for a Sports Wager**

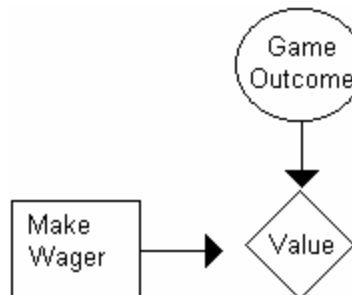

Since both the wager and the game outcome affect the payoff, an arc is drawn from each node into the payoff node. An arc drawn from the chance node to the decision node implies that you know the game outcome before making the wager, while an arc drawn from the decision node to the chance node implies that the game outcome can change depending on the decision you make. In the simplest case, neither of these situations would occur so the two nodes are not connected.

## Guidelines for Using Arcs

### Timing Arcs

Timing arcs demonstrate the flow of information. Information flows between nodes because the decision maker knows the outcome of the predecessor node before making the decision described in the successor node.

### Conditional Arcs

Conditional or "value only" arcs, on the other hand, do not necessarily show time precedence as informational arcs do. They may be reversed using a method called Bayes theorem (described later in this chapter).

How do you decide when to connect two nodes with an arc? The following guidelines may be useful.

#### ***If a...***

*Chance node is successor*

*Decision node is successor*

*Payoff node is successor*

#### ***And...***

*The result of node A is relevant for determining the chance associated with B*

*The result of node A is known before decision B is made*

*The result of node A is relevant for determining the value associated with B*

#### ***Draw...***

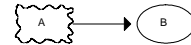
 A conditional arc

 A timing arc

 A conditional arc

## Guidelines for Designing Influence Diagrams

In order to make your model as complete as possible, you should follow these additional guidelines when designing your diagram.

- ◆ ***Your influence diagram should have only one payoff node.***  
*There should only be one endpoint of the analysis, as described by the payoff node.*

### Influence Diagram with Two Payoff nodes

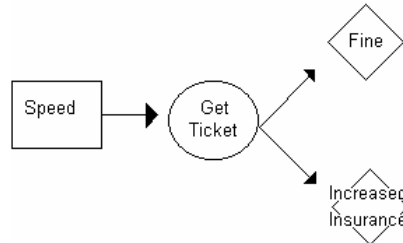

*This example contains two payoff nodes. The cost of the speeding fine and the increase in the insurance premium can be combined into one payoff node.*

- ◆ **Your influence diagram should not contain any cycles.** A cycle is a "loop" of arcs in which there is no clear endpoint. To recognize a cycle, trace back from the payoff node. If you come across the same node more than once in the same path, your diagram contains a cycle. (Note: to form a cycle, all arcs in the cycle must be of the same type)

**Influence Diagram with a Cycle**

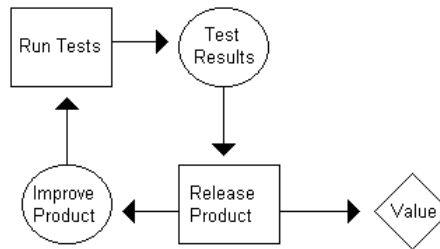

*This example above contains a cycle. Which event occurs first? When does it end?*

- ◆ **Your influence diagram should avoid barren nodes.** Barren nodes are chance or decision nodes that do not have successors, and thus do not influence the outcome of the model. You might want to use barren nodes to illustrate an event, but PrecisionTree ignores these nodes when analyzing the model.

**Influence Diagram with Barren Nodes**

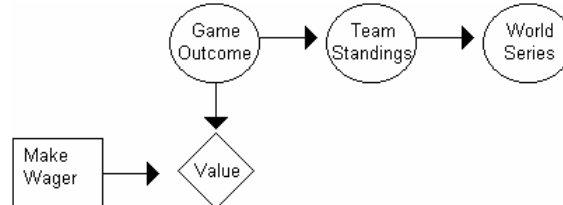

*The diagram above contains two barren nodes. The World Series node is barren since it has no successors. The Team Standings node does have one successor, but since the successor is a barren node, the Team Standings node is also barren.*



# Decision Trees

## Introduction

Decision trees are a comprehensive tool for modeling all possible decision options. While influence diagrams produce a compact summary of a problem, decision trees can show the problem in greater detail. Decision trees describe events in chronological order but can be much larger than influence diagrams.

### Nodes

As with influence diagrams, decision trees also have nodes. In PrecisionTree, decision nodes are drawn as green squares and chance nodes as red circles. But, the payoff node is now called an end node and is represented with a blue triangle. Two additional nodes (logic and reference) are available for advanced model making.

### Branches

Decision trees do not have arcs. Instead, they use branches, which extend from each node. Branches are used as follows for the three main node types in a decision tree:

- A Decision node has a branch extending from it for every available option.
- A Chance node has a branch for each possible outcome.
- ◀ An End node has no branches succeeding it and returns the payoff and probability for the associated path.

## Sports Wager Example - Revisited

The sports wager example discussed earlier can also be modeled with a decision tree. Since the chronology of the model is Make Wager → Game Outcome → Collect Payoff, the decision node begins the tree, followed by the chance node. The end nodes represent the payoffs.

### Decision Tree for a Sports Wager

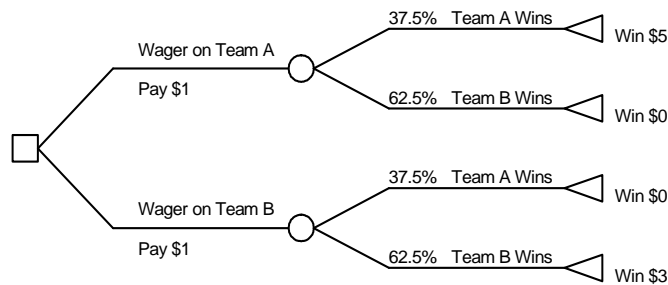

In the above model, the options, values and percentages are visible right on the diagram. But, you can also see a drawback of the decision tree, the tree is much larger than the corresponding influence diagram. Imagine how large a tree can be when there are hundreds of events!

## Event and Fault Trees

What if your model begins with a chance event instead of a decision? A tree that begins with a chance node is called an event tree. A fault tree is a particular type of event tree that shows the relationship of prior events to a particular event and usually models the fault of a complicated system. Typically, a fault tree contains only chance nodes. Unless otherwise noted, PrecisionTree provides the same capabilities for event trees as it does for decision trees.

## Guidelines for Designing Trees

In order to make your model as complete as possible, your tree should represent all possible events as accurately as possible. Follow these guidelines when designing your tree.

- ◆ **Define decision nodes so that only one option may be chosen at each node and every possible option is described.**

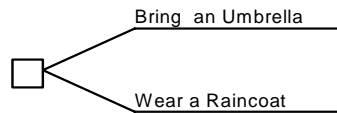

*This example implies that you cannot wear a raincoat and carry an umbrella at the same time. But can't you do both? Unless there is a specific reason why you cannot bring an umbrella when you wear a raincoat, you should include more options in your decision model.*

- ◆ **Define chance nodes so they are mutually exclusive and collectively exhaustive.** A node where only one outcome is possible (but multiple outcomes are described) is mutually exclusive and a node where all possibilities are described is collectively exhaustive.

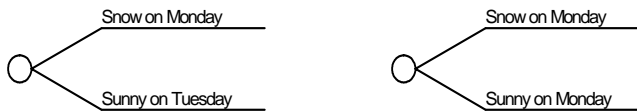

*The first node is not mutually exclusive, it can snow on Monday and be sunny on Tuesday. The second node is not collectively exhaustive, it could rain on Monday.*



◆ *The tree should proceed chronologically from left to right.*

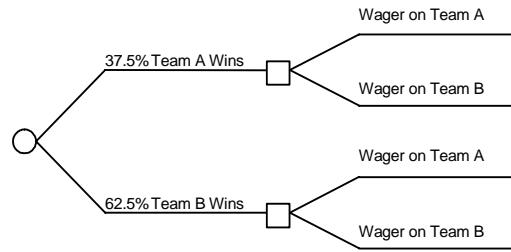

*Putting the chance node first, as in this example, implies that the wager is made after the game is played. In general, you bet on a game before you know the outcome, so the decision node should come first.*



# Influence Diagrams vs. Decision Trees

## A Comparison of the Techniques

As described here, PrecisionTree allows you to create models as either decision trees or influence diagrams. Each form of a decision model has both advantages and drawbacks, and by using each you can create the most comprehensive and understandable model of your decision problem.

### ***Benefits of Influence Diagrams***

Influence diagrams are a compact and efficient method of describing a decision model. As compared to a decision tree, which can have hundreds or thousands of nodes and branches, influence diagrams can show the decisions and events in your model using a small number of nodes, often on a single worksheet. This makes the diagram very accessible, helping others to understand the key aspects of the decision problem without getting bogged down in details of every possible branch as shown in a decision tree. You'll find influence diagrams especially useful for presenting your decision model to others and creating an overview of a complex decision problem. Influence diagrams also show the relationships between events in your decision model – that is, "what influences what?" In a decision tree, it is often difficult to see what outcomes influence the values and probabilities of other events.

### ***Drawbacks to Influence Diagrams***

A drawback to influence diagrams is their abstraction. It is difficult to see what possible outcomes are associated with an event or decision as many outcomes can be embedded in a single influence diagram decision or chance node.

It is also not possible to infer a chronological sequence of events in your decision from the arcs in your influence diagram. This can make it difficult to determine whether the influence diagram and the decision tree it represents accurately depicts the timing present in your decision problem.

### ***Benefits to Decision Trees***

Decision trees, as opposed to influence diagrams, show all possible decision options and chance events with a branching structure. They proceed chronologically, left to right, showing events and decisions as they occur in time. All options, outcomes and payoffs, along with the values and probabilities associated with them, are shown directly in your spreadsheet. This is very little ambiguity as to the possible outcomes and decisions the tree represents; just look at any node and you'll see all possible outcomes resulting from the node and the events and decisions that follow.

In PrecisionTree you can either analyze your decision model directly in your influence diagram or analyze the decision tree which PrecisionTree can create from the influence diagram. Values and probabilities for different possible events and decision options can be entered either in decision trees or influence diagrams.

# Analyzing a Model

Once you have designed a model and defined its parameters, you're ready to run an analysis. A decision analysis on a decision tree or influence diagram produces statistics, graphs and policy suggestions.

In addition to the results produced when a decision analysis is run, many statistics on a decision tree or influence diagram models are available "real-time" as values are entered or edited in a decision model. Typical of these statistics are the expected value of the model and the standard deviation of the risk profile produced by the model.

## Solving Decision Trees

The method for calculating the optimum path in a decision tree is called "folding back." A brief outline of this method is described below.

- ❶ **Chance node reduction** — *calculate the expected value of the rightmost chance nodes and reduce to a single event.*
- ❷ **Decision node reduction** — *choose the optimum path of the rightmost decision nodes and reduce to a single event.*
- ❸ **Repeat** — *return to step 1 if there are nodes that have not been analyzed.*

## Constructing Risk Profiles

The above methods describe how to determine the optimum path in a decision tree. But, you also need to know the consequences of following the suggested path. That's where risk profiles enter the picture.

### What is a Risk Profile?

A risk profile is a distribution function describing the chance associated with every possible outcome of your decision model. The risk profile graphically demonstrates the uncertainty of your decision.

The following steps are performed to construct a risk profile from a decision tree:

- 1 The tree is "collapsed" by multiplying probabilities on sequential chance branches. The value of each path in the tree is calculated by summing the value for each branch in the path. Using this path value, the expected value is calculated for the remaining chance node.

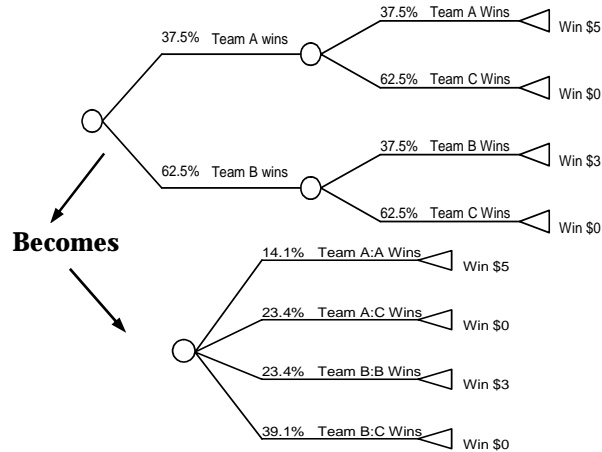

Both trees have an expected value of \$1.40. (EV= \$1.40)

② *Decision nodes are reduced by considering only the optimal branches.*

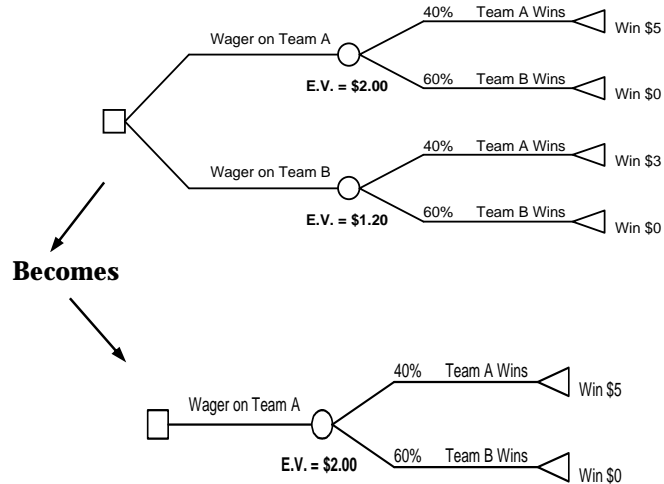

*The decision to Wager on Team A is the optimum decision in this example.*

③ *These steps are repeated until the tree is completely reduced to a single chance node with a set of values and corresponding probabilities  $[X,P]$ . If any two outcomes have the same  $X$  value, they are combined into once chance event and their probabilities are summed.*

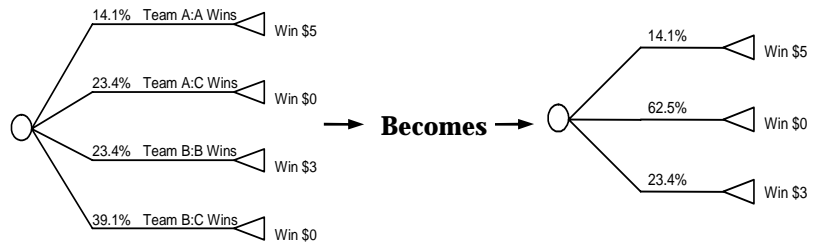

*In the example above on the left, two branches have a value of \$0. The branches are combined as shown in the example on the right.*

④ *The final set of  $[X,P]$  pairs defines a discrete probability distribution which is used to construct the risk profile.*

The risk profile is graphed as a discrete or cumulative density distribution or a scatter diagram. The discrete density distribution shows the probability that the outcome equals a value  $X$ . The

**Risk Profile and Cumulative Risk Profile**

cumulative density distribution shows the probability that the outcome is less than or equal to X.

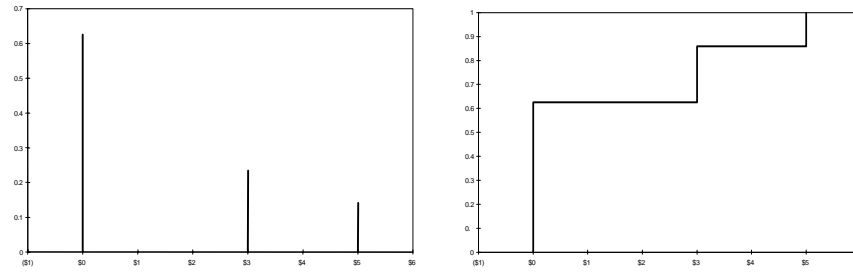

In the risk profile (left), the height of the line at \$0 is 0.625, which is equal to the probability that the wager yields \$0. On the cumulative risk profile (right), the probability that the wager produces a value less than or equal to \$5 is 100%.



**Policy Suggestion**

A Policy Suggestion report lets you know which option was chosen at each node by displaying a reduced version of your tree, with the optimum path highlighted and the value and probability of each path displayed.

**Typical Policy Suggestion**

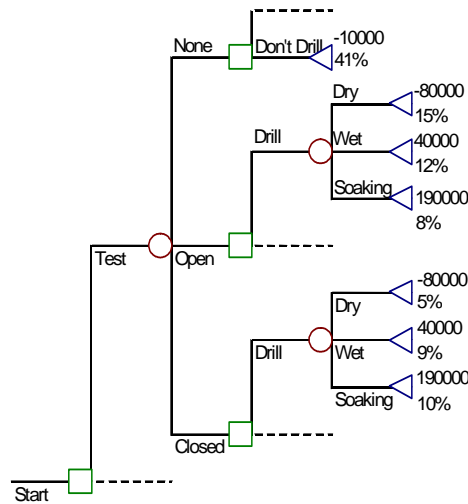

As you can see, only one option is highlighted at each decision node, since only one decision yields the optimum payoff. For chance nodes, however, all branches are highlighted since any of the chance events could occur.



## **Solving Influence Diagrams**

The analysis of an influence diagram generates the same results as analyzing the decision tree which is equivalent to the diagram. In essence, any influence diagram can be converted to a decision tree, and the expected value of the converted tree, along with its risk profile, will be the same as is shown when the influence diagram is analyzed.



# Sensitivity Analysis

Have you ever wondered which variables matter most in your decision? If so, you need sensitivity analysis, which measures the impact of changing an uncertain variable to its extreme values while keeping all other variables constant. Sensitivity analysis can be used on both decision trees and influence diagrams.

## What is Sensitivity Analysis?

By examining the impact of reasonable changes in base-case assumptions, sensitivity analysis determines which variables have little impact on the outcome and can be treated as deterministic (by being set to their average values). This can be very important if your model contains thousands of nodes (or more)! Sensitivity analysis does not give you an explicit answer to your problem, but can help you to better understand your model.

The results of a sensitivity analysis are usually presented graphically. The numerous diagrams and plots demonstrate the impact of variables on the decision.

There are many ways to run a sensitivity analysis on your decision model. None of these ways are better than the others, but each method gives you a different set of information for improving your model. This chapter discusses some of the different types of sensitivity analyses and the graphs produced by them.

## Definition of Terms

Before getting into the details of sensitivity analysis, you should understand some of the special terms used in this chapter:

- ◆ *A **variable** is a value or probability defined in your decision model*
- ◆ *The **base case** value of a variable is the number you entered when you first designed the model (usually the most likely value)*
- ◆ *The **minimum** value of a variable is the lowest possible value you think this variable can reasonably have*
- ◆ *The **maximum** value of a variable is the highest possible value you think this variable can reasonably have*
- ◆ *The number of **steps** is the number of equally spaced values across the minimum-maximum range that will be tested during the sensitivity analysis*

## One-Way Sensitivity Analysis

One-way sensitivity analysis studies the effect of a single variable on the expected value of a model. This value could be either the payoff related to an event (Deterministic Sensitivity Analysis) or the probability related to a chance occurrence (Probabilistic Sensitivity Analysis).

### **Defining a Sensitivity Variable**

Before running a one-way sensitivity analysis, you must decide which variable you wish to study and define the upper and lower bounds of the variable. It's up to you to decide what are reasonable minimum and maximum values for the variable in question.

At the beginning of a sensitivity analysis, the base case values of all variables are placed into the model and the expected value is calculated. This value can be referred to as the base case of the model, and is the value that all subsequent results are compared to.

During the calculation process, the base case value of the variable is replaced with its minimum value and a new expected value is calculated. Then, a set of values ranging from the minimum value for the variable up to its maximum are substituted in and the expected value is calculated for each. Finally, the variable is returned to its original value in preparation for analysis of another variable.

When running a sensitivity analysis, it is important to define reasonable limits for your variables in order to avoid exaggerating the uncertainty of the variables. In addition, remember to consider the uncertainty in your limits.

## One-Way Sensitivity Graphs

The results of a one-way sensitivity analysis can be plotted on a simple diagram. The value of the selected variable is plotted on the X-axis and the expected value of the model is plotted on the Y-axis.

### **One-Way Sensitivity Graph**

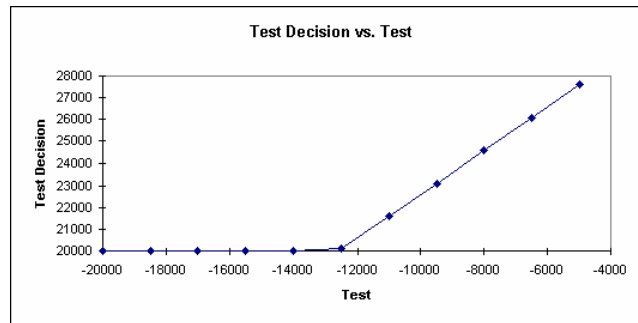

## Tornado Graphs

A Tornado Graph compares the results of multiple analyses. The X-axis is drawn in the units of the expected value. For each variable (listed on the Y-axis), a bar is drawn between the extreme values of the expected value calculated from the lower and upper bound values. A vertical line marks the base case value. The variable with the greatest range (the difference between the maximum and minimum value) is plotted on the top of the graph, and the variables proceed down the Y-axis with decreasing range. The longest bar in the graph is associated with the variable that has the largest impact on expected value.

### Typical Tornado Graph

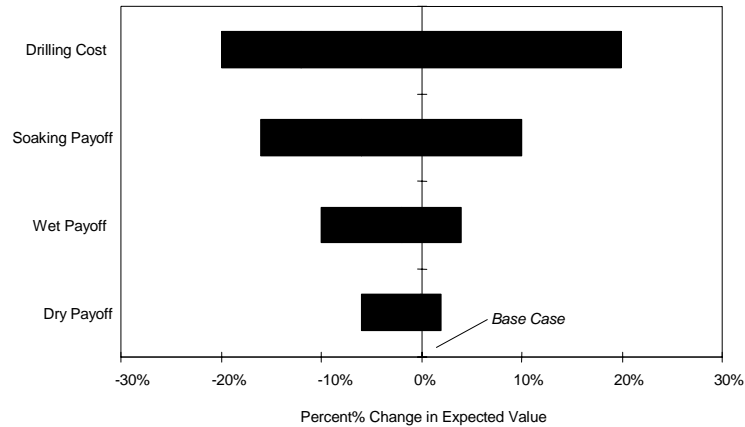

The Tornado Graph brings attention to the variables that require further attention (those plotted on the top of the graph). The Tornado Graph can summarize the impact of an almost unlimited number of variables in a neat, simple graph.

## Spider Graphs

A spider graph also compares the results of multiple analyses. For each variable, the percentage of the base case is plotted on the X-axis and the expected value of the model is plotted on the Y-axis. The slope of each line depicts the relative change in the outcome per unit change in the independent variable and the shape of the curve shows whether a linear or non-linear relationship exists. In this graph, the total variation in the *Value1* has the largest total effect on expected value, but each unit of change in *Prob1* causes the greatest unit change in expected value. This is shown in a steeper line for *Prob1* as compared to *Value1*.

### Typical Spider Graph

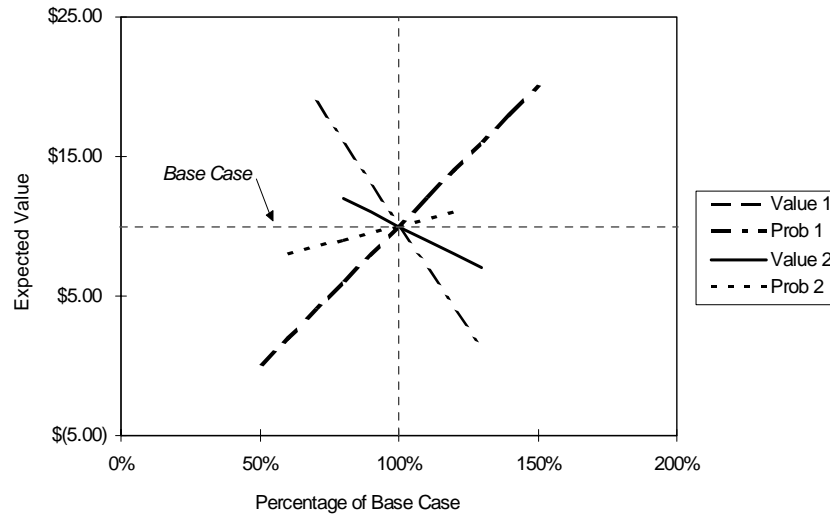

Spider graphs provide more information about each variable than Tornado Graphs. For example, spider graphs show the reasonable limits of change for each independent variable and the unit impact of these changes on the outcome. While Tornado Graphs may lead the decision maker to think that risk is proportional, the slope of spider graphs demonstrate any unproportional changes in outcomes.

The number of variables used in a spider graph should not exceed seven, but a limit of five is recommended to avoid clutter. If your sensitivity analysis contains a large number of variables, it is a good idea to plot them on a Tornado Graph first to determine which variables have the greatest impact. Then, use only these variables on your spider graph.

## Two-Way Sensitivity Analysis

Two-way sensitivity analysis studies the impact of two variables on a decision model. Typically, the two most critical variables are studied.

### Defining the Sensitivity Variables

During the calculation, all the possible combinations in value for the two variables are generated and placed in the variable cells. The resulting calculated value for the model is saved for each combination.

The results of a two-way sensitivity analysis can be plotted on a 3D graph. The value of the first variable is plotted on the X-axis and the value of the second variable is plotted on the Y-axis. The value of the decision model is plotted on the Z axis. The points calculated by the two-way sensitivity analysis are plotted and a surface is drawn to connect them.

## Strategy Region Graphs

Strategy region graphs show regions where different decisions are optimal given changes in two selected variables. The value of the first variable is plotted on the X-axis and the value of the second variable is plotted on the Y-axis. The strategy region graph is very similar to the two-way Sensitivity Graph, but the graph now shows the regions where each possible decision is optimal. For example, your decision to start your own business or invest your money "safely" may depend on expected sales and the cost of raw materials.

When a decision node is selected as the output of a two-way sensitivity analysis a strategy region graph can be created. The optimal decision at each of the input variable combinations tested during the sensitivity analysis is plotted on the graph.

### Typical Strategy Region Graph

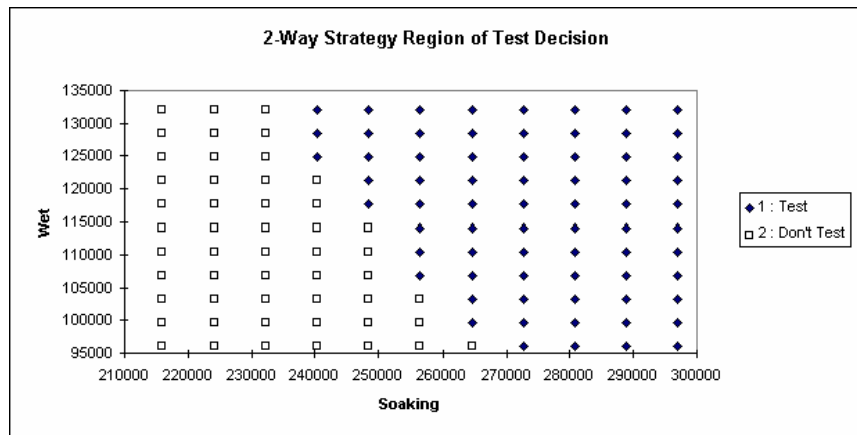

This diagram suggests whether to Test or Not to Test. By studying the possible combinations in value for the two input variables you can determine which decision is optimal at different possible input values.





---

# Chapter 3: Overview of PrecisionTree

<b>Introduction .....</b>	<b>41</b>
On-line Tutorial.....	41
<b>A Quick Overview to PrecisionTree .....</b>	<b>43</b>
PrecisionTree Toolbar and Menu .....	43
Defining Nodes .....	44
Running a Decision Analysis .....	46
Decision Analysis Results.....	46
Running a Sensitivity Analysis .....	48
Sensitivity Analysis Results.....	48
<b>Setting Up a Decision Tree .....</b>	<b>49</b>
Defining the Decision.....	49
Creating a New Tree .....	50
Creating a Decision Node.....	50
Creating a Chance Node.....	53
Completing the Tree.....	54
<b>Setting Up an Influence Diagram .....</b>	<b>57</b>
Creating a New Influence Diagram.....	57
Entering a Chance Node .....	58
Adding Other Influence Diagram Nodes.....	59
Entering Influence Arcs .....	60
Entering Influence Node Values.....	63
<b>Analyzing a Decision Model.....</b>	<b>67</b>
Running a Decision Analysis .....	67
Running a One-Way Sensitivity Analysis .....	71
Running a Two-Way Sensitivity Analysis.....	75
Strategy Region Graphs .....	76
<b>Advanced Features.....</b>	<b>77</b>



# Introduction

This chapter provides an introduction to PrecisionTree and the process of setting up a decision tree using PrecisionTree and Excel. The chapter includes the following three sections:

- ◆ ***A Quick Overview to PrecisionTree*** - a quick look at a decision tree in PrecisionTree and the results of a decision analysis
- ◆ ***Setting Up a Decision Tree*** - a step-by-step guide to creating a decision tree
- ◆ ***Setting Up an Influence Diagram*** - a step-by-step guide to creating an influence diagram
- ◆ ***Running a Decision Analysis*** - an overview of running a decision analysis and sensitivity analysis
- ◆ ***Advanced Features*** - an overview of additional features of PrecisionTree that can be used in building your decision models

## On-line Tutorial

The material in this chapter is included in the on-line tutorial provided with PrecisionTree. This tutorial can be started by clicking the icon titled *The PrecisionTree Tutorial* in the PrecisionTree program group. The time required to complete this tutorial is under ten minutes.



# A Quick Overview to PrecisionTree

This section of the *Overview to PrecisionTree* provides a quick look at PrecisionTree and the results of a decision analysis. You'll see how a simple decision tree looks in an Excel spreadsheet and see the types of reports and graphs PrecisionTree creates.

## PrecisionTree Toolbar and Menu

PrecisionTree extends the analytical capabilities of your Microsoft Excel spreadsheet to include decision analysis using decision trees and influence diagrams. To add decision analysis capabilities to your spreadsheet, PrecisionTree uses both a toolbar and menu commands.

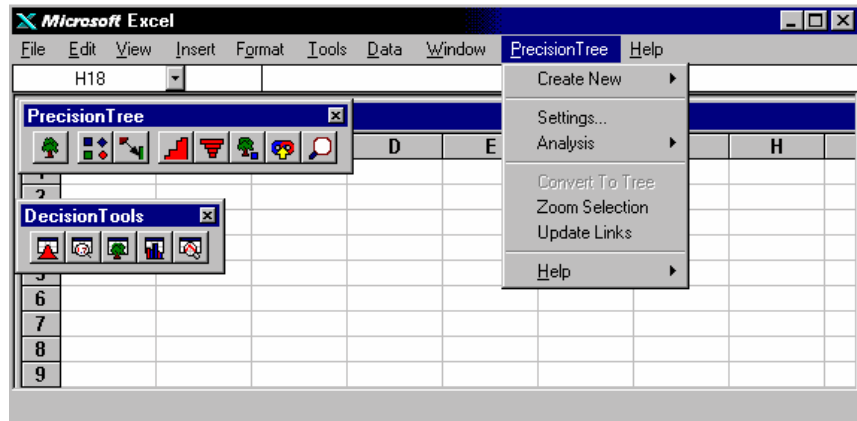

PrecisionTree creates a new menu “PrecisionTree” on the Excel menu bar. This menu contains commands for designing and analyzing decision trees and influence diagrams. The PrecisionTree toolbar contains icons which provide easy access to PrecisionTree menu commands. The DecisionTools toolbar, also added by PrecisionTree, contains icons for launching the other applications in the DecisionTools Suite.

The toolbar and menu commands are used to make selections from your spreadsheet "add-in" style. Decision trees and influence diagrams are designed directly in a spreadsheet and all PrecisionTree results and graphs are generated as Excel charts or spreadsheets for further customization and presentation.

## Defining Nodes

In PrecisionTree, nodes of an influence diagram or decision tree are defined directly in your spreadsheet. For a decision tree, the probabilities and values associated with the branches from a node are entered directly in spreadsheet cells next to each branch. Each node returns a value representing the expected value or certainty equivalent of the decision model at the node. For an influence diagram, the probabilities and values associated with the possible outcomes for a node are entered in a Value table which is displayed when the node is selected. This table is a standard Excel spreadsheet with cells, rows and columns.

PrecisionTree provides an easy-to-use interface which enters nodes in your spreadsheet automatically. Once a tree is started, nodes are edited or added by clicking on node symbols in your worksheet. Influence diagram nodes are added by clicking the Add Influence Node icon on the toolbar.

### Decision Tree Defined with PrecisionTree

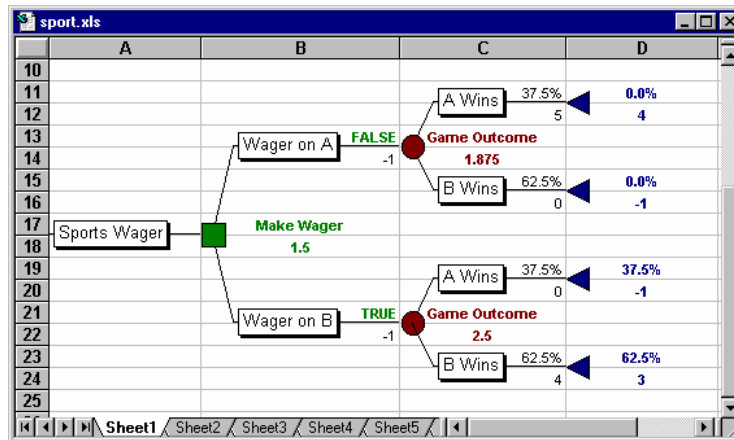

In a decision tree in PrecisionTree, decision nodes are represented by green squares, chance nodes by red circles and end nodes by blue triangles. The name of each node and the value of the tree at the node are shown next to each node symbol. Each branch has a label and two values, in cells above and below the branch. For a chance node, the two values are branch probability and branch value. For a decision node, the top cell for each branch has a TRUE or FALSE, indicating whether the branch was selected. The cell below the branch contains the branch value. For an end node, two values are shown – the probability of the path through the tree occurring and the value if the path does occur.

***Influence  
Diagram Defined  
in PrecisionTree***

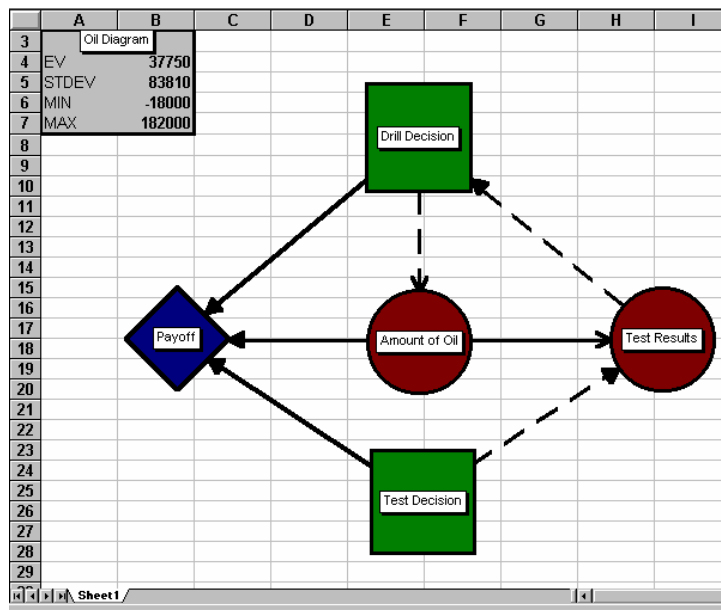

In an influence diagram in PrecisionTree, decision nodes are represented by green squares, chance nodes by red circles, calculation nodes by blue rounded rectangles and payoff nodes by blue diamonds. The name of each node is shown inside each node symbol. Clicking on the node symbol allows you to enter or edit the outcomes for a node and their values. Influence arcs are shown as arrows between nodes. Different forms of influence between nodes may be entered by clicking on an arc.

***Results Shown  
in a Decision  
Tree or  
Influence  
Diagram***

PrecisionTree displays a set of results for your decision model in your spreadsheet "real-time", with your results changing immediately as you enter or edit values in your model. These results include the expected value of the model along with the minimum, maximum and standard deviation of the risk profile for the model. These values are shown either at the root of a decision tree or in the top left of the worksheet containing an influence diagram. Just as with other spreadsheet models, you can change a value in your model and immediately see the effect on your results. When you run a full decision analysis, these real-time results are supplemented with additional reports and graphs on your model.

## Running a Decision Analysis

Once a decision model has been defined using either a decision tree or influence diagram, you are ready to run a decision analysis. The decision analysis finds the optimum path through the decision tree or influence diagram and calculates the possible outcomes on this path.

To run an analysis, select the Decision Analysis command from the Analysis submenu on the PrecisionTree menu or click the Decision Analysis icon on the PrecisionTree toolbar. Then, select the tree or influence diagram (or start node for a subtree) that you wish to analyze. For more information on how a decision analysis is performed, please refer to the *Overview of Decision Analysis*.

## Decision Analysis Results

PrecisionTree decision analysis results include a distribution of possible results for your model (called a risk profile). In addition, PrecisionTree determines the optimum path through the model to create a policy suggestion. These results are presented in Excel worksheets and charts.

### Typical Risk Profile Graph

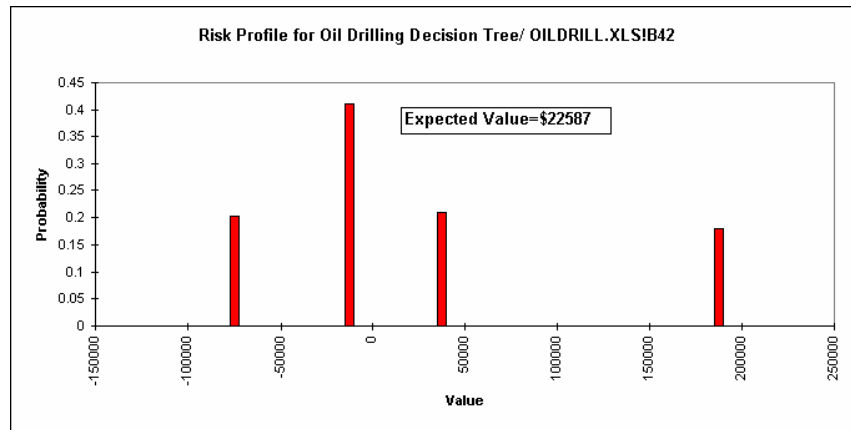

A risk profile is a distribution function describing the chance associated with every possible outcome of your decision model. The risk profile graphically demonstrates the uncertainty of your decision using a frequency or cumulative frequency graph (this information is also represented in a statistical report).



## Typical Policy Suggestion

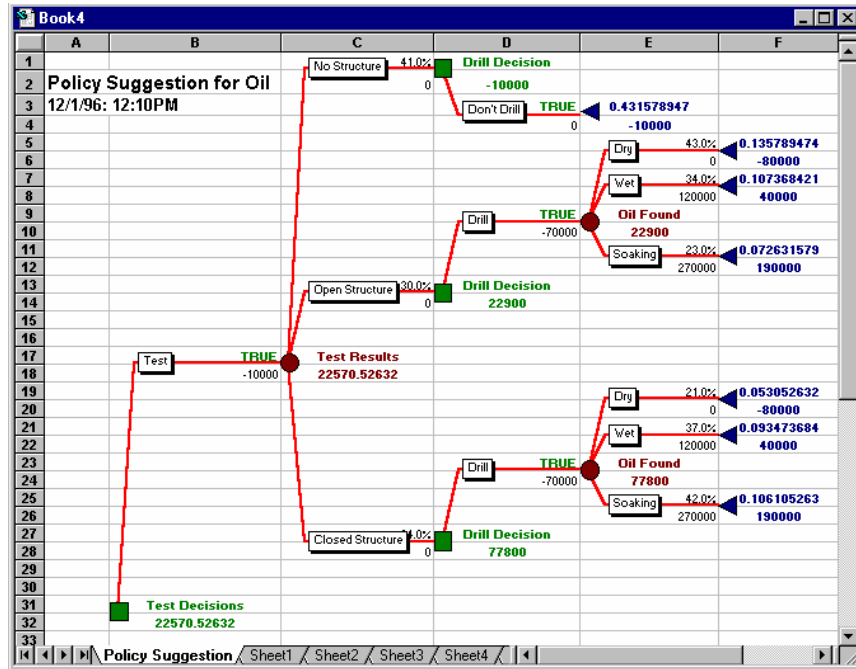

For a decision tree, PrecisionTree Pro also offers a policy suggestion report, letting you know which option was chosen at each node. The report, an enhanced version of your tree, is drawn directly in a spreadsheet with the optimum path highlighted and the expected value of each node displayed.

## Running a Sensitivity Analysis

You may wonder how much a value in your model affects the outcome of your decision. For example, how much does the expected value of a model change if one of the payoffs increase? Sensitivity analysis tells you just how "sensitive" your model is to changes in certain variables.

PrecisionTree runs both a one-way sensitivity analysis (which analyzes one variable at a time) and a two-way sensitivity analysis (which studies how a combination of two variables affect the outcome). To run an analysis, select the *Sensitivity Analysis* command from the Analysis submenu on the PrecisionTree menu. PrecisionTree prompts you for the cell to analyze and the cell(s) to vary. For more information on how a sensitivity analysis is performed, please refer to the *Overview of Sensitivity Analysis*.

## Sensitivity Analysis Results

The results of a PrecisionTree sensitivity analysis are presented graphically in Excel charts. PrecisionTree creates Tornado Graphs, spider plots, strategy region graphs and more. Each graph helps you determine how important a variable is to the outcome of your decision.

**Typical  
One-Way  
Sensitivity  
Graph**

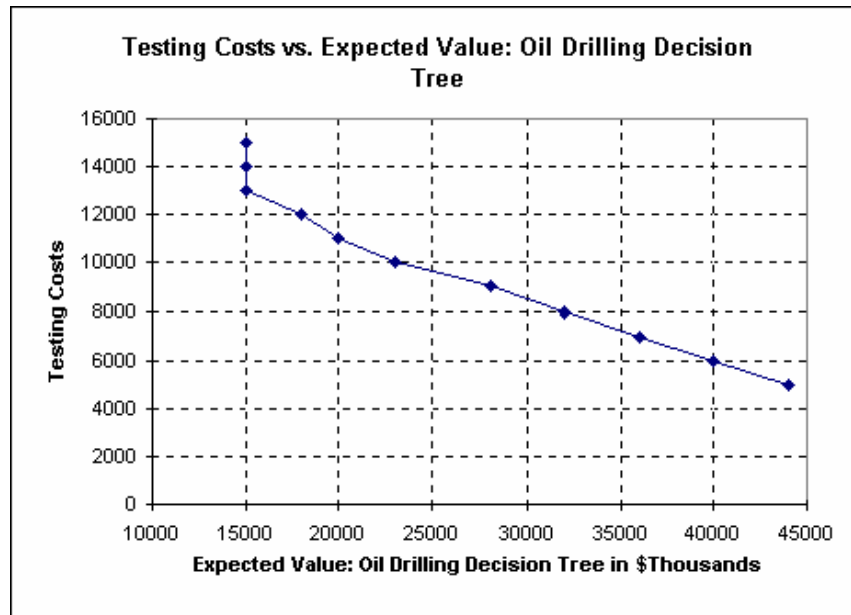

# Setting Up a Decision Tree

This section of the *Overview to PrecisionTree* provides a more in-depth look at the process of setting up a decision tree in Excel using PrecisionTree. You'll learn how to create a decision tree by defining nodes and branches.

To define a decision tree model, you'll use the commands on the PrecisionTree menu or toolbar. If you're not familiar with decision trees, please read the *Overview to Decision Analysis* first. This section assumes that you understand basic decision analysis concepts and techniques.

## Defining the Decision

To design a decision tree, you must define the events involved in your decision. Unlike influence diagrams, events in a decision tree progress in chronological order.

For example, let's look at the classic oil-drilling example:

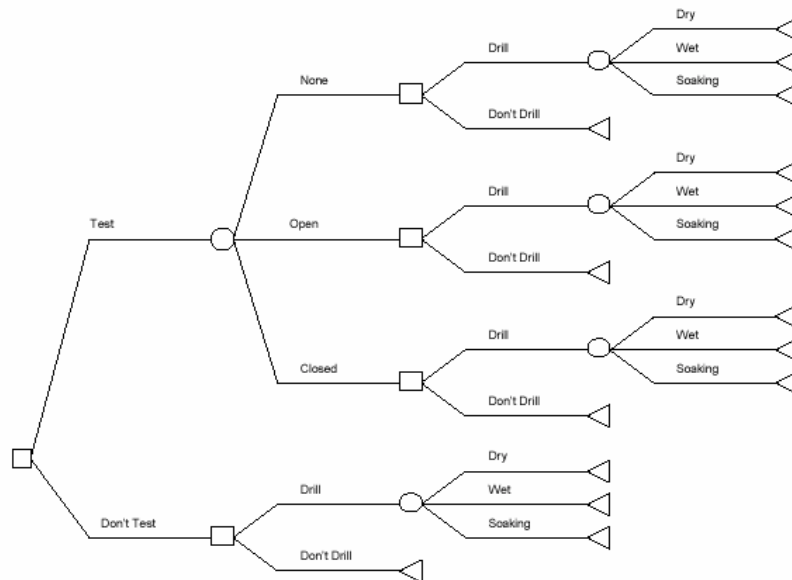

Our first decision is whether to run geological tests on the prospective site. Then, depending on the test results, the next decision is whether to drill for oil. The final chance event is the amount of oil found. The tree progresses from left to right – the decision to test is always made before the decision to drill.

## Creating a New Tree

To create a decision tree using PrecisionTree, first select the *Create New Tree* command on the PrecisionTree menu or click the *Create New Tree* icon on the PrecisionTree toolbar. For the oil drilling example, you'll create a standard decision tree. PrecisionTree also allows you to create a linked tree, where branch values are linked to a model in your spreadsheet. In *Chapter 5: Modeling Techniques*, you'll see how to create the same oil drilling model as a linked tree. The two different types of trees each have a different method for calculating the payoffs from the decisions represented in the tree.

### Naming Your Decision Tree

When the *Create New Tree* icon is clicked, a single branch representing the "root" or start of your tree is created, followed by a single End Node (a blue triangle). Let's call this tree "Oil Drilling". To do this, click the NewTree label on the tree's single branch.

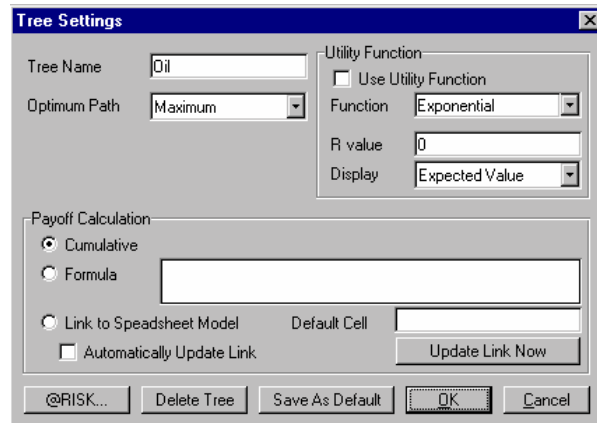

The *Tree Settings* dialog box is displayed, showing the name of this new tree, along with the settings for the tree. For now, just leave the Settings at their default values. Change the name of the tree to Oil Drilling and click OK.

## Creating a Decision Node

To create a new decision node, click the single end node (the blue triangle) that was created when you created the new tree. This allows you to edit this node's definition, changing it from an end node to a decision node. Clicking on the decision node icon in the *Node Settings* dialog box – a green square – changes the end node to a decision node. For the oil drilling example, a decision node with two possible outcomes, "Test" and "Don't Test", represents our initial decision.

## Node Settings Dialog Box

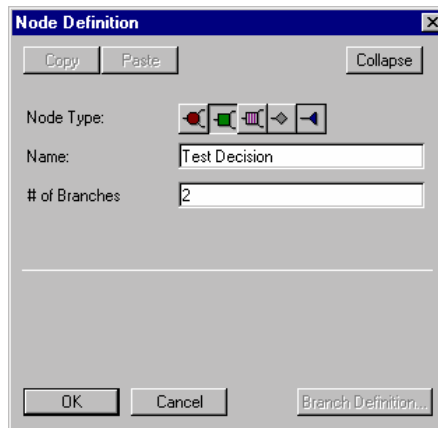

In this example, the name of our decision node is “Test Decision”. There are two branches (or decision options) following the node. After entering the node’s name, # of branches and clicking OK, PrecisionTree will create a new decision node in the spreadsheet. This node has two branches that, by default, are labelled *Branch1* and *Branch2*.

## Entering Branch Names and Values

For each branch from a decision node there is a label and a value. In PrecisionTree, the values, probabilities and labels for all nodes and branches in a decision tree are entered directly in your Excel worksheet. For the Test Decision decision node the two branches are named *Test* and *Don’t Test*. You type these labels directly in the spreadsheet, replacing the default *Branch*.

A branch value is also needed for each branch from the decision node. Since testing costs \$10,000, the value for the Test branch is -10000. If we don’t test, our value is 0 since there are no costs associated with that option. You type these values directly in the spreadsheet, in the cell below the branch name. This is where the default branch value of 0 is located.

Since the decision has two outcomes, two branches extend to the right of the node to an end node. Each end node is represented with a blue triangle. These end nodes show the value and probability of the path through the tree which terminates at the end node.

## Testing Decision

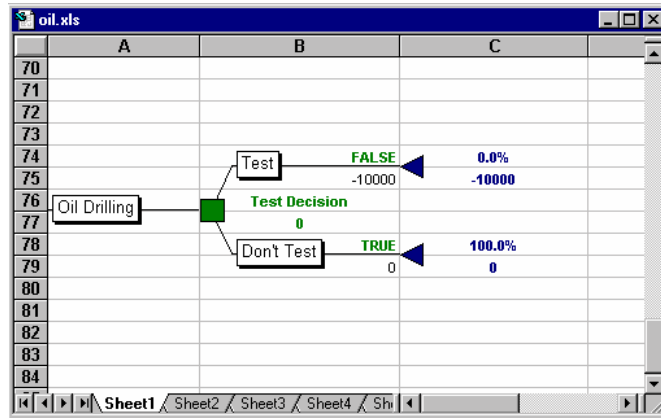

All nodes return the expected value or certainty equivalent of the node. This value is shown in the cell beneath the node name. The method used to calculate these values depends on the default settings for the model.

Each branch from a decision node has a TRUE or FALSE label. If a branch is selected as the optimum path, TRUE is shown. Unselected branches display FALSE.

## Creating a Chance Node

Once the decision to test has been made, a chance node is used to define the results of the test (a prediction of the amount of oil present). This node should extend to the right of the Test outcome, replacing the existing end node.

To replace an end node with a chance node, click on the end node to be replaced, displaying the Node Settings dialog box. Then, click the Chance node icon next to *Node Type*. The chance node icon is a red circle.

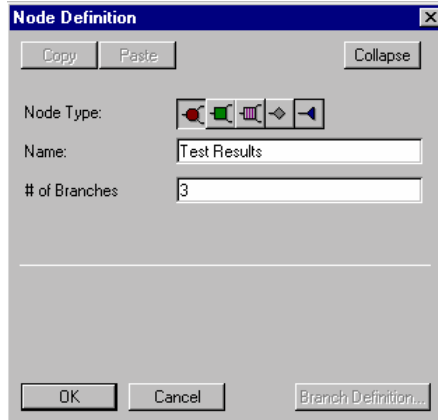

There are three branches (or possible outcomes) from the node. After entering the node's name and # of branches and clicking OK, PrecisionTree creates a new chance node in the spreadsheet. This node has three branches that, by default, are labelled *Branch*.

### **Entering Branch Names, Values and Probabilities for a Chance Node**

For each branch from a chance node there is a label, value and probability. For the Test chance node there are three possible results: *No Structure*, *Open Structure* or *Closed Structure*. These labels are typed directly in the spreadsheet, replacing the default *Branch1*, *Branch2* and *Branch3*. Each branch has a value of 0, since there are no additional costs incurred or payments received based on the test results. Thus, no change is required to the default branch value of 0 shown in the spreadsheet.

The probability of each outcome occurring is 41%, 35% and 24% respectively. These values are typed directly in the spreadsheet in the cell above each branch, replacing the .33 displayed in each cell. (Note: a default value of .33 was displayed because PrecisionTree split the total probability evenly among the three branches). In this case, the branch probabilities sum to 100%. In cases where the probabilities do not sum to 100%, the values are normalized by PrecisionTree when the tree is evaluated.

**Location of Values and Labels in a Decision Tree**

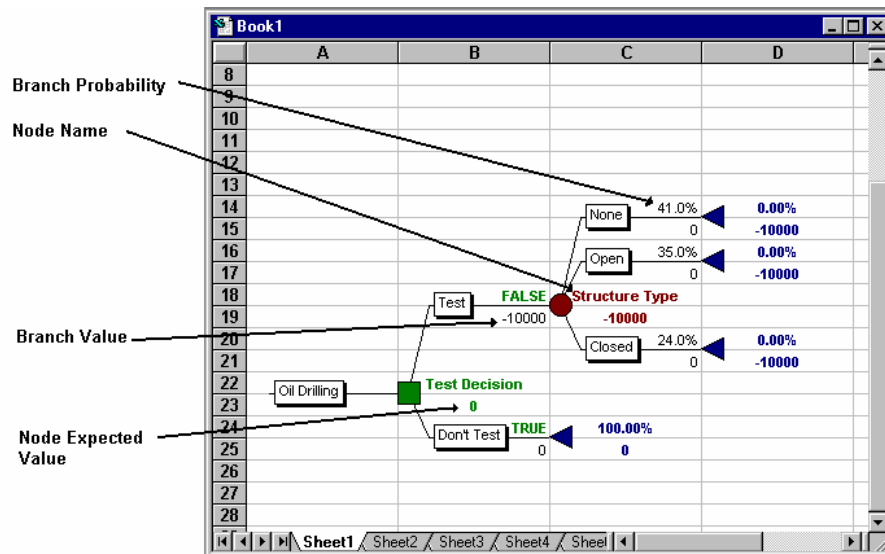

Notice the layout of the decision tree PrecisionTree has drawn for you. In the cell next to each node is the name of the node and its expected value. You can see the names, values and probabilities for each node's branches next to the branches themselves. You can edit these values and labels directly in your spreadsheet if you decide to change the definition of a branch.

**Completing the Tree**

The entire decision can be defined using the methods described above. For the oil drilling example, each outcome is followed by a decision to drill and the amount of oil found.

**Complete Oil Drilling Decision Tree**



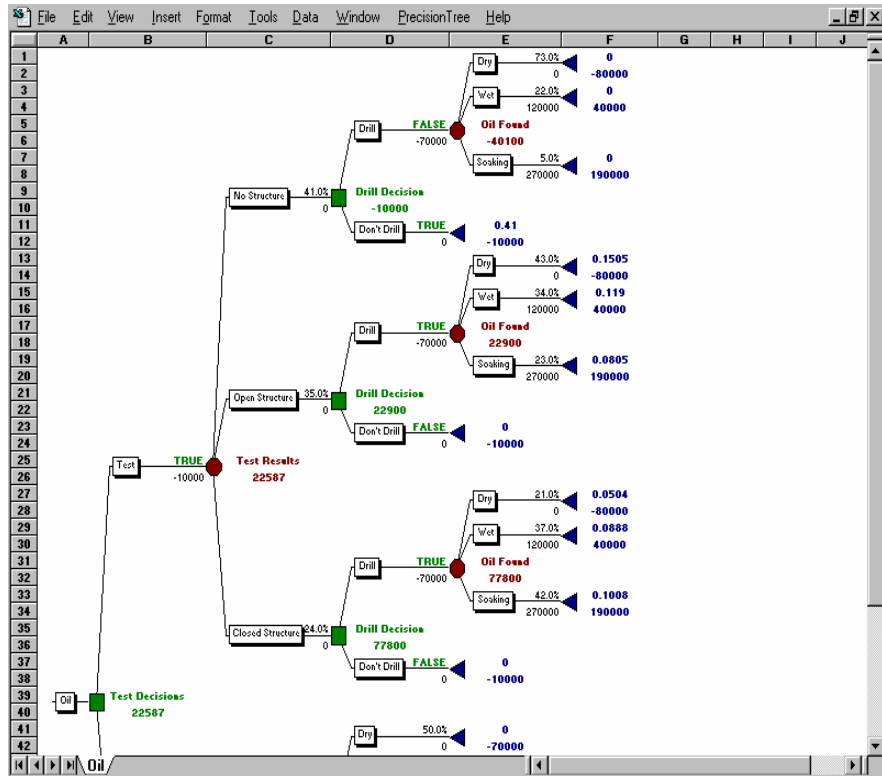

The screen above shows the top section of the completed oil drilling decision tree. At the end of each path in the decision tree are end nodes. The payoff and probability for each path through the tree are returned by the end nodes. In this example, the payoff returned depends on the cost of testing, the cost of drilling and the amount of oil found.

***The example workbook OIL.XLS contains the oil drilling example described in this section.***



# Setting Up an Influence Diagram

This section of the *Overview to PrecisionTree* provides a more in-depth look at the process of setting up an influence diagram in Excel using PrecisionTree. You'll learn how create an influence diagram by defining nodes and arcs. In addition, you'll specify values and probabilities for the possible outcomes represented by the nodes in an influence diagram in tables in a spreadsheet. The influence diagram created here will be for the oil drilling problem which was modelled using a decision tree earlier in this chapter.

To define an influence diagram, you'll use the commands on the PrecisionTree menu or toolbar. If you're not familiar with influence diagrams, please read the *Overview to Decision Analysis* first. This section assumes that you understand basic decision analysis concepts and techniques.

## Creating a New Influence Diagram

A new influence diagram is created when the *Create New Influence Diagram or Node* icon is clicked and there is no influence diagram on the current worksheet. When this icon is clicked, the cursor changes to a cross-hair, allowing you to use the mouse to drag and create a node at the position you want in your worksheet. The name of the diagram – the default *Diagram#1* - is shown in the top left of the current worksheet. The influence node dialog box is displayed, allowing you to enter the name, outcomes and values for the new node.

**Influence Node  
Dialog Box**

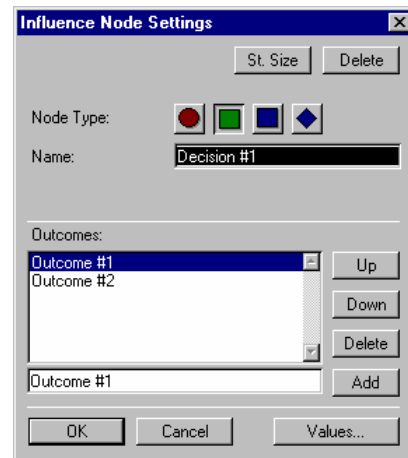

As with decision tree nodes, a dialog box allows you to select the type of node to add to your influence diagram, name the node and, for decision and chance nodes, enter the possible outcomes for the node.

The available node types in an influence diagram are:

- **Chance nodes** (represented by red circles) representing events that have a set of possible uncertain outcomes.
- **Decision nodes** (represented by green squares) where a set of possible decision options are available.
- **Calculation nodes** (represented by rounded blue rectangles), that take results from predecessor nodes and combine them using calculations to generate new values. There are no options or uncertainty associated with calculation nodes.
- **Payoff node** (represented by a blue diamond), that calculates the final outcome of the model. Only one payoff node is allowed in each influence diagram.

The influence node dialog box also allows you to display the Value table for a node. This is the table where the probabilities and values for the possible outcomes for the node are entered.

## Entering a Chance Node

The first node for the oil drilling influence diagram is a chance node named *Amount of Oil*. This node, directly or indirectly, influences many of the other nodes in your model. To set up this node, first change the name of the initial node in the diagram from the default *Chance#1* to *Amount of Oil*. There are three possible outcomes for *Amount of Oil* – *Dry*, *Wet* and *Soaking*. By clicking the *Add* button, a third outcome can be added to the default *Outcome #1* and *Outcome#2*. Then, enter the name of each outcome in the text box beneath the outcome list.

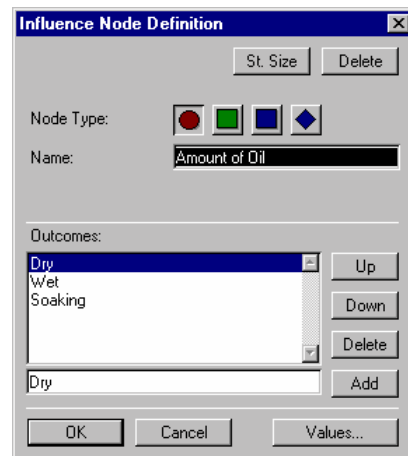

## Viewing Influence Diagram Settings

With the first node added to the diagram, let's review the model settings for the influence diagram and change the name of the diagram to *Oil Drilling Model*. To do this, click on the name *Diagram#1* in the top left corner of the worksheet.

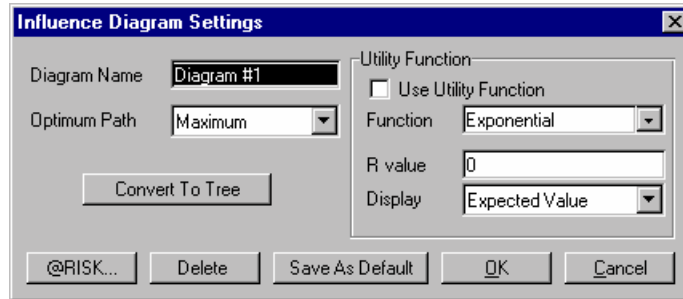

The displayed settings control how PrecisionTree calculates results from your influence diagram, specifying which path through the diagram to follow and whether or not to apply a utility function to model calculations. These settings also allow you to set up your diagram as a linked model, just as you can do with a decision tree. For now, we'll just change the name of the diagram from the default *Diagram#1* to *Oil Drilling Model*.

## Adding Other Influence Diagram Nodes

Now, we'll add the remaining nodes and their possible outcome names to our diagram. By clicking the Influence Node icon and dragging the cursor where you want each node positioned, add:

- 1) A decision node, *Test Decision*, with two options, *Test and Don't Test*.
- 2) A chance node, *Test Results* with, three possible outcomes, *None, Open and Closed*.
- 3) A decision node, *Drill Decision*, with two options, *Drill and Don't Drill*.
- 4) A final Payoff node, *Profits*.

**Influence  
Diagram with  
Only Nodes**

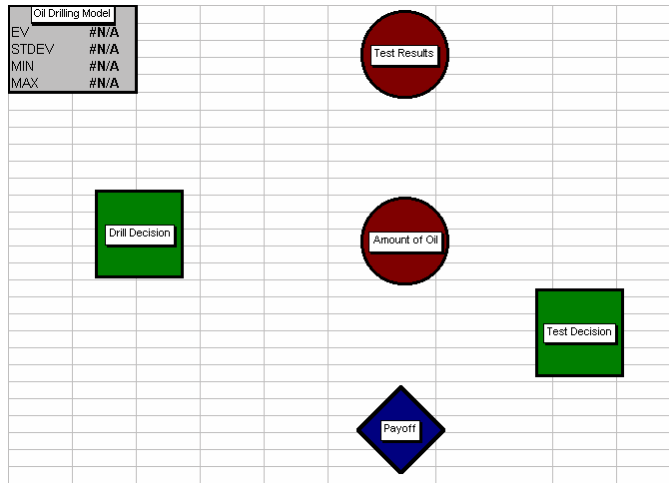

The Oil Drilling influence diagram, with all nodes entered, is shown above. The next step in creating this decision model is to connect the nodes with arcs that indicate the relationships among the elements of the model.

**Entering Influence Arcs**

An influence diagram has arcs between nodes to indicate relationships between decisions, chance events, calculation nodes and payoffs . Arcs, for example, can indicate that an outcome which occurs for one node influences the values and probabilities used for another node.

In our diagram here, the *Amount of Oil* chance node influences two other nodes – *Test Results* and the payoff node, *Profit*. The values for *Profit* and *Test Results* (and the probabilities for *Test Results*) are influenced by the outcome which occurs for the *Amount of Oil* – i.e., a value for *Profit* and *Test Results* will be specified for each possible outcome for *Amount of Oil* - *Dry, Wet and Soaking*. This influence is shown in the diagram by drawing an arc from the node *Amount of Oil* to *Profit* and *Test Results*. Arcs are drawn by clicking the Influence Arc icon and drawing a line from the *Amount of Oil* node to each of the other two nodes.

Each time you draw an arc, the Influence Arc dialog box is displayed, allowing you to enter the type of influence the arc describes.

**Influence Arc  
Dialog Box**

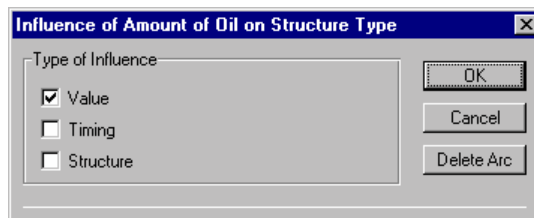

### **Types of Influence Between Nodes**

Some influence arcs specify a value influence as described here between *Amount of Oil* and *Profit*. Other arcs only indicate *timing* - when one event occurs prior to another, or *structure*, when an outcome for one event affects the outcomes which occur for another event (or whether the event takes place at all!). An arc can specify multiple types of influence; for example, an arc from *Test Decision* to *Payoff* describes not only a value influence but also a timing influence, as the *Test Decision* is made prior to the *Payoff* calculation being performed.

Timing and structure influence are important when your influence diagram is converted to a decision tree. They specify which events precede others in the converted decision tree (timing influences) and which nodes are "skipped" and branches ""pruned off" when certain outcomes occur. This allows you to make what is know as an "asymmetric" tree. The decision tree which represents the Oil Drilling problem is an asymmetric tree as some paths (such as *Don't Test - Don't Drill*) have fewer nodes and branches than other paths (such as *Test - Drill - Oil Found*).

### **Adding Arcs Between All Nodes**

To define all relationships for the Oil Drilling model, the following influence arcs with specified influence types are added to the Oil Drilling model:

- 1) An arc from *Test Decision* to *Payoff*; influence type is **value and timing** as the cost of testing influences the payoff calculation.
- 2) An arc from *Test Results* to *Drill Decision*; influence type is **timing** only, as the outcome for the Test Results is known prior to the drilling decision.
- 3) An arc from *Drill Decision* to *Amount of Oil*; influence type is **structure only**, as the amount of oil is not known prior to the drilling decision; however, if the decision is made not to drill, the *Amount of Oil* node is skipped; i.e., you'll never know the amount of oil without drilling.
- 4) An arc from *Test Decision* to *Test Results*; influence type is **timing and structure**, as the decision to test happens prior to the Test Results outcome being known; however, the decision to test has no effect on the outcome for Test Results except that the *Test Results* node is skipped if you don't test; i.e., you'll never know the Test Results without testing.
- 5) An arc from *Drill Decision* to *Payoff*; influence type is **value and timing** as the cost of drilling influences the payoff calculation and precedes that calculation chronologically.

## Entering Structure Influence

When each arc is entered, the appropriate influence type is selected in the influence type dialog box. When a structure influence is desired, it is necessary to specify how the predecessor node will effect the structure of the outcomes from the successor node. The selections which appear when the Structure influence type is selected are used to do this.

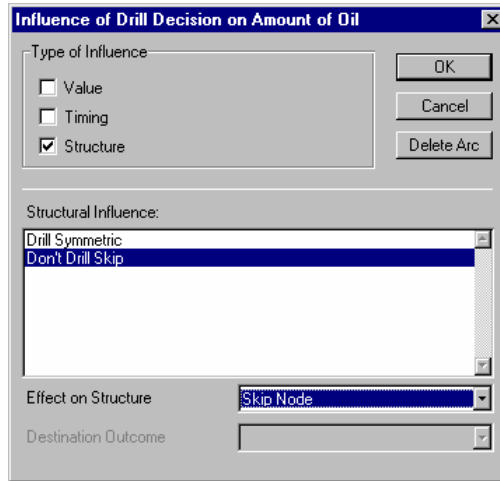

Each of the outcomes from the predecessor node (in this case, *Drill Decision* outcomes) can have a structural influence on the outcomes from the successor node (*Amount of Oil*). By default, structure influence is symmetric; that is, each outcome for the successor node is possible at each outcome for the predecessor node. In the case of the arc from *Drill Decision* to *Amount of Oil*, however, the amount of oil node will be skipped when drilling is not performed. To specify this, *Skip Node* is set as the structure influence type for the *Don't Drill* outcome of *Drill Decision*.

## Completed Influence Diagram Structure

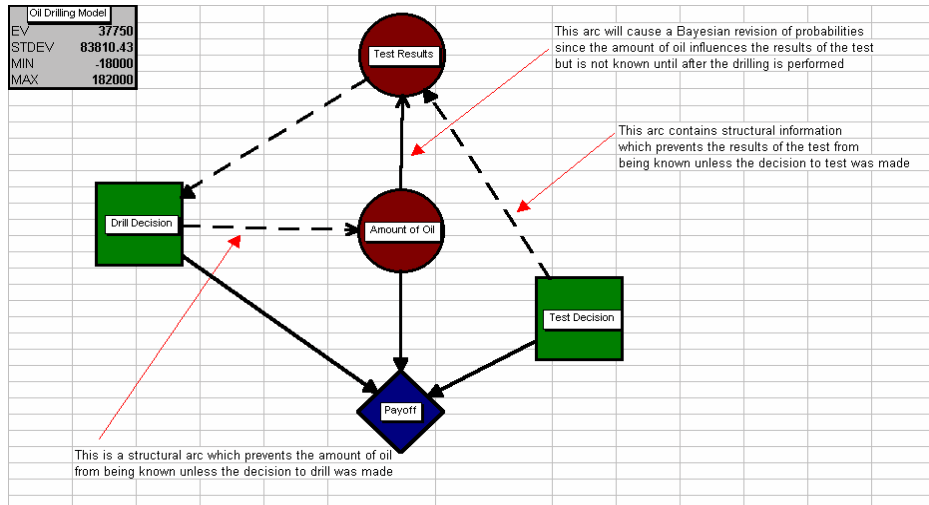



Once the appropriate influence types have been entered for each arc in the diagram, the structure of your model is complete. Now, all that remains is to enter the values for the outcomes for each node.

## Entering Influence Node Values

Clicking the Values button in an Influence Node dialog box displays the Value table for an influence diagram node. A Value table is used to enter the values for the possible outcomes for the node (and, for a chance node, probabilities of those outcomes). A value is entered for each possible combination of values of the predecessor, or influencing, nodes.

Influence Value Editor		
OK		
Cancel		
Amount of Oil	Value	Probability
Value when skipped		
Soaking	270000	0.5
Wet	23000	0.3
Dry	0	0.2

The Value table is a standard Excel spreadsheet with values of influencing nodes shown. In the Value table, values and probabilities are entered in the two white columns. In the table above, the possible values for Amount of Oil and their probabilities of occurrence are shown.

The *Amount of Oil* chance node influences the probabilities of the *Test Results* chance node. There are three different possible outcomes for *Test Results* - *None*, *Open* and *Closed*. (There are no values associated with these structure types, only probabilities). For each possible outcome for *Amount of Oil*, a different probability is entered for each structure type.

### Value Table for Test Results

Influence Value Editor			
OK			
Cancel			
Test Results	Value	Probability	Amount of Oil
Value when skipped			
No Structure		0.1	Soaking
Open Structure		0.3	Soaking
Closed Structure		0.6	Soaking
No Structure		0.2	Wet
Open Structure		0.5	Wet
Closed Structure		0.3	Wet
No Structure		0.4	Dry
Open Structure		0.5	Dry
Closed Structure		0.1	Dry

**Bayesian Revision**

In the influence diagram, probability information was entered for *Test Results* at each possible outcome for *Amount of Oil*. These events, however, occur in the opposite sequence chronologically - you find out the *Test Results* prior to the determining the *Amount of Oil*. In the converted decision tree, the order of these nodes will be "flipped" and revised probabilities calculated using a process known as *Bayesian Revision*. This happens automatically when PrecisionTree calculates the results for an influence diagram or converts your influence diagram to the equivalent decision tree.

**Entering Remaining Node Values**

To complete the Oil Drilling influence diagram it is necessary to fill in the value tables for the remaining influence diagram nodes. The following tables show the values for each node that are entered.

**Test Decision Values**

Influence Value Editor	
Test Decision	Value
Value when skipped	
Test	10000
Don't Test	0

**Drill Decision Values**

Influence Value Editor	
Drill Decision	Value
Value when skipped	
Drill	43000
Don't Drill	0

**Payoff Node Values**

For payoff nodes, formulas can be used to combine values for influencing nodes to calculate node values. These formulas are standard Excel formulas and can reference outcome values listed in the value table or other cells in open worksheets.

**Payoff Values**

Payoff	Value	Amount of Oil	Drill Decision	Test Decision
	=D4-E4-F4	Soaking	Drill	Test
	=D6-E6-F6	Wet	Drill	Test
	=D6-E6-F6	Dry	Drill	Test
	=F7		Don't Drill	Test
	=D10-E10-F10	Soaking	Drill	Don't Test
	=D11-E11-F11	Wet	Drill	Don't Test
	=D12-E12-F12	Dry	Drill	Don't Test
	0		Don't Drill	Don't Test

When entering the formula for the Payoff node, a formula is entered in the Value cell that sums the *Amount of Oil*, *Test Decision* and *Drill Decision* cells. In the Value table above, the first cell sums the values for *Dry*, *Drill* and *Test* outcomes (cells D4, E4 and F4 in the Value table where the labels *Dry*, *Drill* and *Test* are located). By entering a reference in a formula to a cell where an outcome's name is located, you are instructing PrecisionTree to use the values for the shown outcome when generating the *Payoff* value. This formula is then just copied to the other value cells, just like other Excel formulas. All cell references are automatically updated by Excel.

**Profit Payoff Values**

Oil Diagram	
EV	128000
STDEV	107373.2
MIN	43000
MAX	227000

With all values and probabilities entered for the nodes in the influence diagram, the expected value of the model, along with the minimum, maximum and standard deviation of results can be seen in the upper left of the worksheet. These values are calculated "real-time" just as are other spreadsheet results. Change a value or probability in your diagram and you'll immediately see the impact on the results of your model.



# Analyzing a Decision Model

## Introduction

PrecisionTree offers two methods for analyzing decision trees and influence diagrams: decision analysis and sensitivity analysis. Decision analysis determines the optimum path through your model, telling you which decisions are the best given certain chance outcomes. Sensitivity analysis measures the affect of the uncertainty in each variable on your model. Please refer to the *Overview of Decision Analysis* and the *Overview of Sensitivity Analysis* for more information.

### **Real-Time Decision Model Results**

A decision analysis supplements the standard statistics on your decision model which are provided real-time as you enter or edit values in your decision tree or influence diagram. These statistics, which include the expected value of the model, along with the minimum, maximum and standard deviation of possible outcomes, are shown in the grey box at the root of a decision tree or in the top left corner of the worksheet which contains an influence diagram.

## Running a Decision Analysis

To run a decision analysis, use the *Decision Analysis* command on the *Analysis* submenu of the PrecisionTree menu or click the *Decision Analysis* icon on the PrecisionTree toolbar. A dialog box appears that allows you to select which decision tree or influence diagram you wish to analyze. If you wish to analyze a small part of a decision tree (a subtree) select a node other than the start node in the dialog box.

If your model begins with a decision node, PrecisionTree offers a multi-decision option. In addition to analyzing the optimum decision, PrecisionTree can analyze every other initial decision for comparison.

During an analysis, PrecisionTree determines every possible path value and the probability associated with each. These results are used to construct a distribution function called a risk profile.

These results can be displayed in a statistical report, which lists the risk profile and relevant statistics for each initial decision. The report can be generated in a new workbook or a workbook where the model is located.

**Statistics Report**

	A	B	C	D	E
1	<b>PrecisionTree Statistics Report</b>				
2	For Oil of oil.xls				
3	Created on 7/11/2000 at 4:44:50 PM				
4					
5	<b>Test Decision</b>	1 : Test		2 : Don't Test	
6					
7	<b>STATISTICS</b>				
8	Mean	22587		20000	
9	Minimum	-80000		-70000	
10	Maximum	190000		200000	
11	Mode	-10000		-70000	
12	Std Dev	87715.43		103923	
13	Skewness	0.919699		0.721688	
14	Kurtosis	2.789759		2.083333	
15					
16	<b>PROFILE:</b>				
17	#	X	P	X	P
18	1	-80000	0.2009	-70000	0.5
19	2	-10000	0.41	50000	0.3
20	3	40000	0.2078	200000	0.2
21	4	190000	0.1813		

In this example, the two initial decisions in the model were analyzed: "Test" and "Don't Test." The expected value of the tree is 22,587 when the initial decision is to test. When the initial decision is not to test, the expected value decreases to 20,000. So, based only on expected value, testing seems to be the optimum decision.

The risk profile graph displays the information as a discrete density distribution for each possible outcome. Each line of the graph shows the probability that the outcome will equal a certain value. The expected value of the decision is also displayed. The graph is generated in a new chart in a new workbook on a sheet named *Risk Profile*.

**Risk Profile Graph**

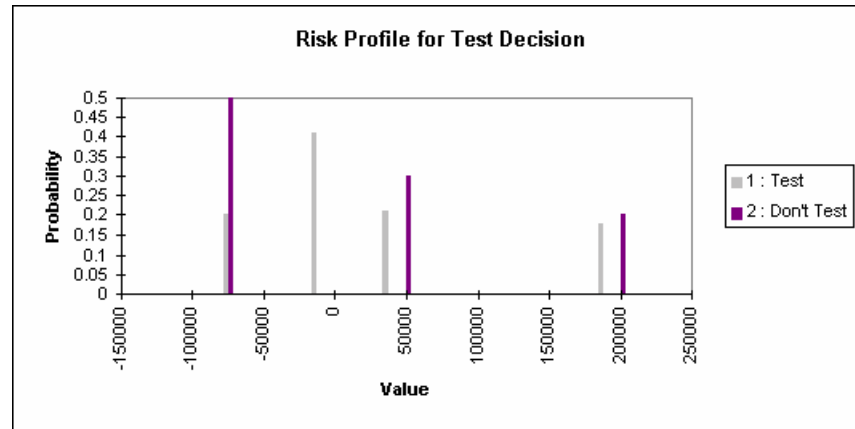

In the Risk Profile above, four possible outcomes are displayed for the Test decision and three possible outcomes for the Don't Test decision

with the probability of each displayed. The cumulative risk profile graph displays a cumulative distribution showing the probability of an outcome less than or equal to a certain value. The expected value of the decision is also displayed. As with the risk profile graph, the graph is generated in a new chart in a new workbook on a sheet named *Cumulative Risk Profile*.

**Cumulative Risk Profile Graph**

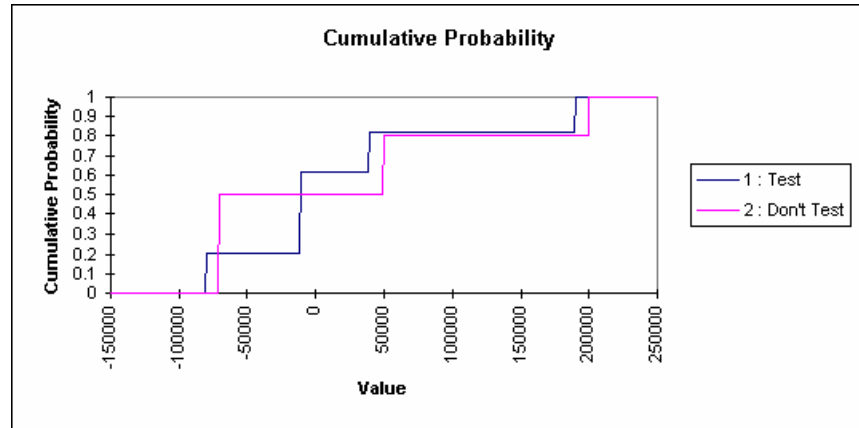

The Cumulative Risk Profile Graph above again demonstrates probability of an outcome falling below zero when testing is done is around 60%



During the decision analysis of a decision tree, PrecisionTree also finds the optimum path in order to construct a policy suggestion report (PrecisionTree Pro only). The policy suggestion report is a reduced version of the decision tree which displays only the optimum decisions in your model.

**Policy  
Suggestion  
Report**

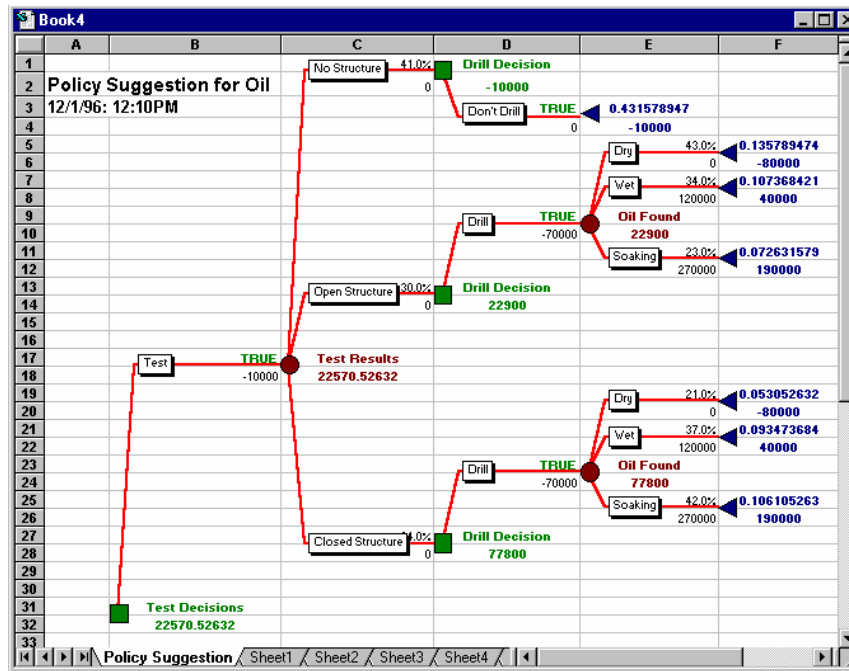

In this example, PrecisionTree suggests selecting to Test. Then, depending on the test results, PrecisionTree suggests drilling in some cases (“Open” and “Closed”) and not drilling in others (“None”). If we follow these suggestions, there is a 21% chance the well will be “Dry”, when the test results are “Closed” and a 43% chance it will be “Dry” when the test results are “Open.”



  
**Sensitivity  
Analysis  
Command**

## Running a One-Way Sensitivity Analysis

To run a one-way sensitivity analysis, use the *Sensitivity Analysis* command on the *Analysis* submenu or click the *Sensitivity Analysis* icon on the PrecisionTree toolbar. The *Sensitivity Analysis* dialog box appears, prompting you for information on the cells you wish to include in the sensitivity analysis.

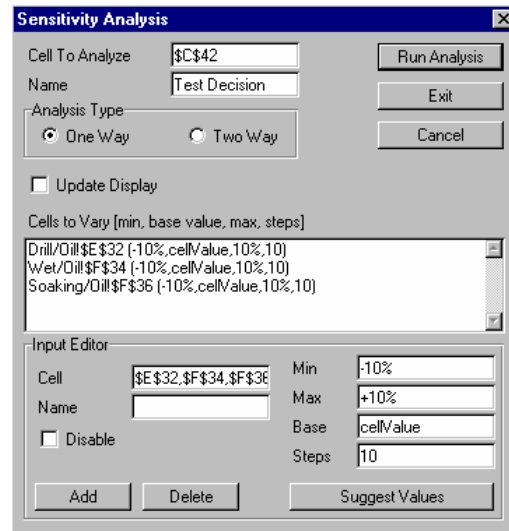

To study the effects of a variable on an entire model, enter the cell containing the value for the root of the tree or the expected Value of the influence diagram as the *Cell to Analyze*. To study the effects on a small part of a decision tree (a sub-tree), enter the cell containing the value for the start node of the subtree as the *Cell to Analyze*.

During a sensitivity analysis, PrecisionTree modifies the value(s) of the sensitivity variable(s) you specify (the *Cells to Vary*) and records the changes in the expected value of the *Cell to Analyze*. For one-way sensitivity analyses, one variable is changed at a time. Reports generated by this analysis include one-way sensitivity graphs, tornado graphs and spider graphs. The results of many one-way analyses can be compared on the same tornado graph or spider graph.

A one-way sensitivity graph displays the change in the expected value of the *Cell to Analyze* as the *Cell to Vary* changes. This graph, as well as the other graphs described in this section, is generated in a new chart within the workbook containing your results.

**One-Way Sensitivity Graph**

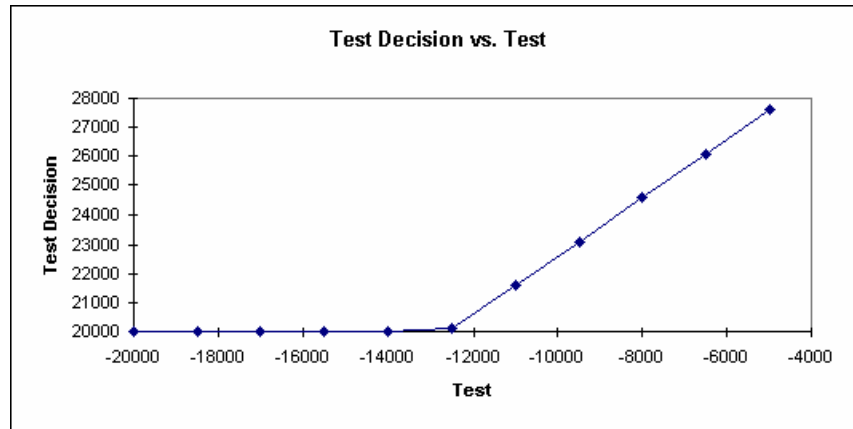

In the example above, the cost of testing was varied. According to the one-way sensitivity graph, the expected value of the model is not affected by the test cost when it rises above around 13,000 (since “Don’t Test” becomes the optimum decision).

**One Way Strategy Region Graph**

A one-way strategy region graph displays the results of each possible initial decision at each value tested in a one-way sensitivity analysis (Pro version only). The *Cell to Analyze* must be the value of a decision node for this analysis to be performed.

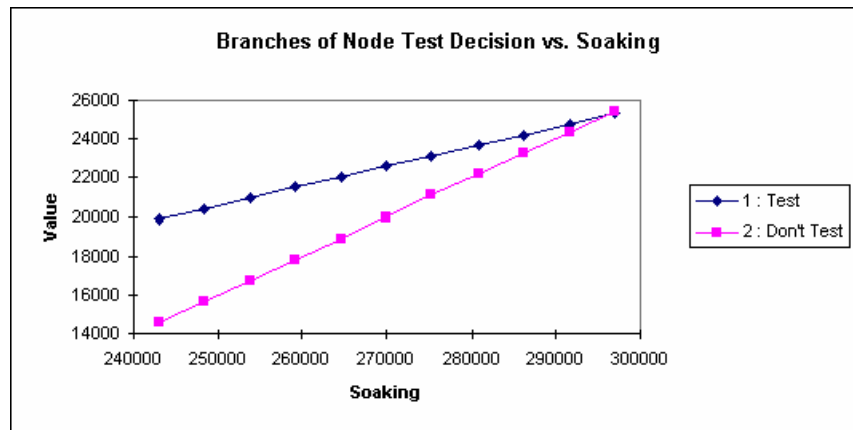

A tornado graph displays the changes in the expected value of the *Cell to Analyze* for each *Cell to Vary*. A new bar is added to the graph for each *Cell to Vary* in the one-way sensitivity analysis.

### Tornado Graph

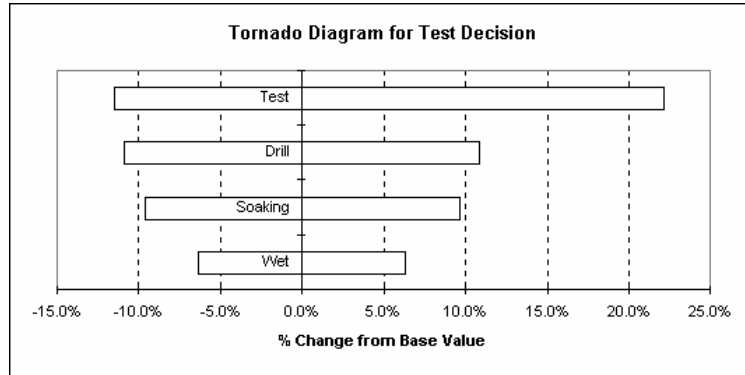

In the Tornado Graph here, Testing Costs, Drilling Costs and Soaking and Wet Field Size were varied by 10%. According to PrecisionTree, the expected value of the model is more sensitive to changes in Testing Costs (the larger bar).

A spider graph displays the percentage change in the expected value of the *Cell to Analyze* as each *Cell to Vary* changes for each analysis. A new line is added to the graph for each *Cell to Vary* included in the Sensitivity Analysis.

### Spider Graph

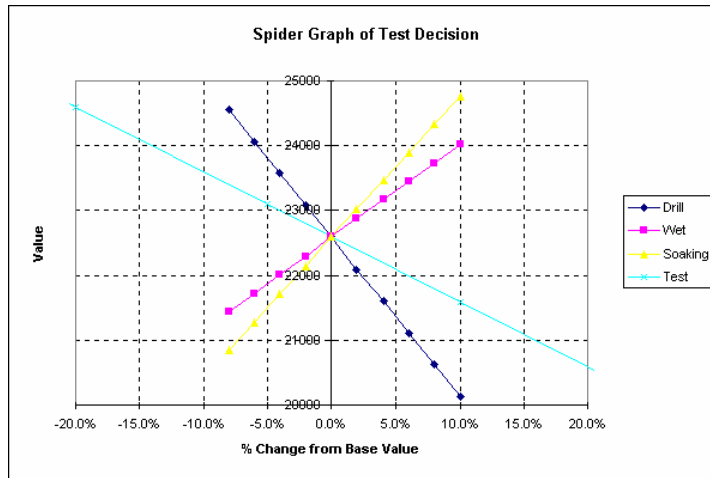

In the spider graph above, Testing Costs, Drilling Costs and Soaking and Wet Field Size were varied by 10%. According to PrecisionTree, the expected value of the model is most sensitive to changes in the cost of testing. Notice that the slope of the testing cost line is much steeper, that means that a smaller % change in the cost of testing leads to a larger change in the expected value of the model.

## Running a Two-Way Sensitivity Analysis



### Sensitivity Analysis Command

For two-way sensitivity analyses, two variables are changed simultaneously. To run a two-way sensitivity analysis, use the *Sensitivity Analysis* command on the *Analysis* submenu or click the *Sensitivity Analysis* icon on the PrecisionTree toolbar.

Reports generated by this analysis include two-way sensitivity graphs and strategy region graphs. During the analysis, PrecisionTree finds the value of the *Cell to Analyze* at each possible combination of values for the *Cells to Vary*. PrecisionTree then displays the results as a 3D graph, with values for the Cells to Vary on the X and Y axis and the values for the Cell to Analyze on the Z axis.

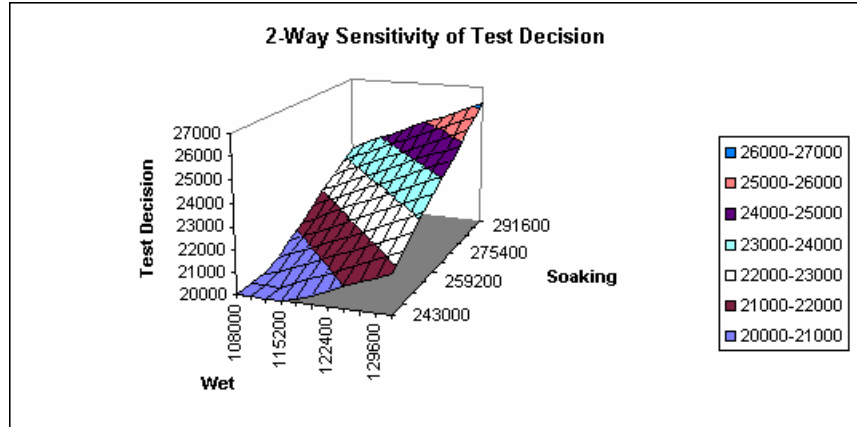

## Strategy Region Graphs

Strategy region graphs show regions where different decisions are optimal given changes in two selected variables. The value of the first variable is plotted on the X-axis and the value of the second variable is plotted on the Y-axis. The different symbols in the graph denote the optimal decision at various combinations of values for two variables - in this case, the Wet field value and the Soaking field value.

The strategy region graph here shows the optimal decision for the possible combinations in value for Wet and Soaking. When Wet and Soaking each approach their minimum values the decision Don't Test becomes optimal.

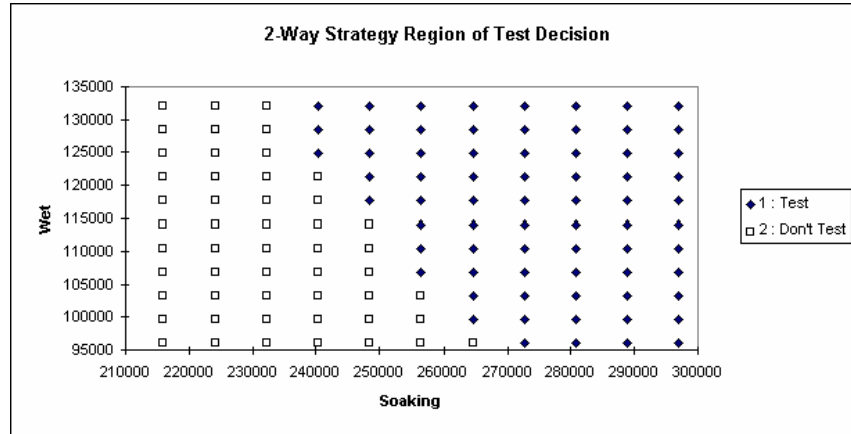

# Advanced Features

## Overview

PrecisionTree offers many advanced features that can greatly enhance your decision models. This section gives an overview of many of these features. For additional information on using the features described here, see *Chapter 4: Modeling Techniques* and *Chapter 5: The PrecisionTree Command Reference*.

### **Linked Trees**

Linked trees allow the branch values for a decision tree to be linked to cells in a Excel model that is external to the tree. By linking values, end node payoffs can be calculated by a detailed spreadsheet model.

In a linked tree, each node can be linked to an Excel cell reference or range name. When a linked tree is recalculated, branch values on each path in the tree are substituted into the designated cells in the Excel model and the payoff is calculated. End node payoffs are then taken from the cell specified as the location of the payoff value.

### **Defining Branch Values, Probabilities and Logic in Cells**

Branch values and probabilities entered in the spreadsheet (in the cells above and below a branch) can be defined by entering a value directly in the cell or by entering any valid Excel formula. For branch probabilities, entered values are normalized so that the sum of all branch probabilities from the node equals one.

### **Logic Nodes**

Logic nodes are a special type of node where the optimum branch is not selected using the PrecisionTree settings for path selection. Instead, decisions are made according to conditions the user defines. The name of the node derives from the fact that the pre-set conditions are usually phrased in a logic statement (using expressions such as "less than", "equal to", etc.). There is a logic statement (in PrecisionTree called "branch logic") associated with each branch from the node. This statement is simply a standard Excel formula that returns a TRUE or FALSE in your spreadsheet when evaluated. A logic node is symbolized by a purple square. A logic node behaves like a decision node, but it selects the branch whose branch logic formula evaluates to TRUE as the logical (optimum) decision.

**Decision  
Defined by a  
Logic Node**

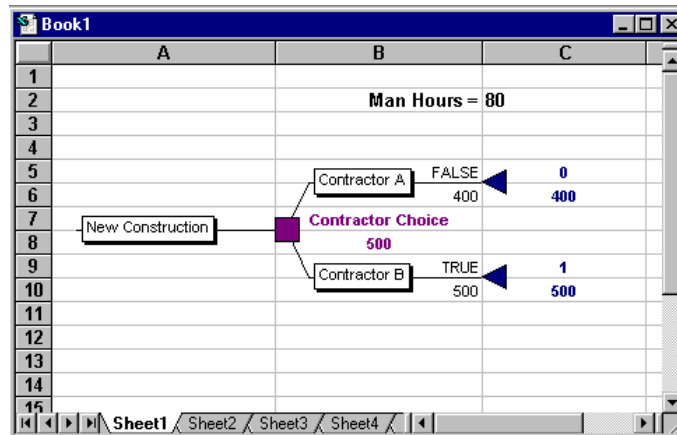

This example contains a variable Man\_Hours and a situation where you want to choose Contractor A if Man\_Hours is less than 100 and Contractor B otherwise. Using a logic node, the probability of selecting either Contractor A or Contractor B is defined with the formulas:

```
=Man_Hours>100
=Man_Hours<=100
```

PrecisionTree selects the first option as the optimum path whenever Man\_Hours are greater than 100 and the second option otherwise. The value for the Contractor A branch is 400 while the value for the Contractor B branch is 500.

If two or more branches of a logic node evaluate to TRUE, all TRUE branches are optimal and equally likely to occur. The logic node returns the weighted average of the value for each TRUE path. If all branches evaluate to FALSE, the logic node returns #VALUE.

***Note: A branch for a decision node will also display TRUE when it is the selected branch or decision option. If more than one branch has the optimal path value (i.e., the paths from two branches have the same expected value or utility), the topmost branch will be followed and labelled TRUE.***



**Using  
Distribution  
Functions as  
Branch Values**

@RISK distribution functions allow a range of possible values to be entered for values and probabilities in your decision trees and supporting worksheet models. Wherever values are used in your models, distribution functions may be substituted. During a standard decision analysis, these functions will return their expected values. These are the values that will be used in calculating all decision analysis results.

When a simulation is run using @RISK, a sample will be drawn from each distribution during each iteration of the simulation. The node values in the decision tree will then be recalculated using the new set of samples and the results recorded by @RISK. A range of possible values for nodes selected as simulation outputs will then be displayed by @RISK.

**Reference  
Nodes**

Reference nodes can be used to reference a separate tree or a sub-tree with the current tree. The referenced tree can be present in the same worksheet or on a different worksheet in the same workbook. Use reference nodes to simplify a tree, to reference the same sub-tree many times in a tree, or when a tree becomes too large to fit on one spreadsheet.

A reference node is symbolized by a gray diamond.

**Decision Tree  
Using Reference  
Nodes**

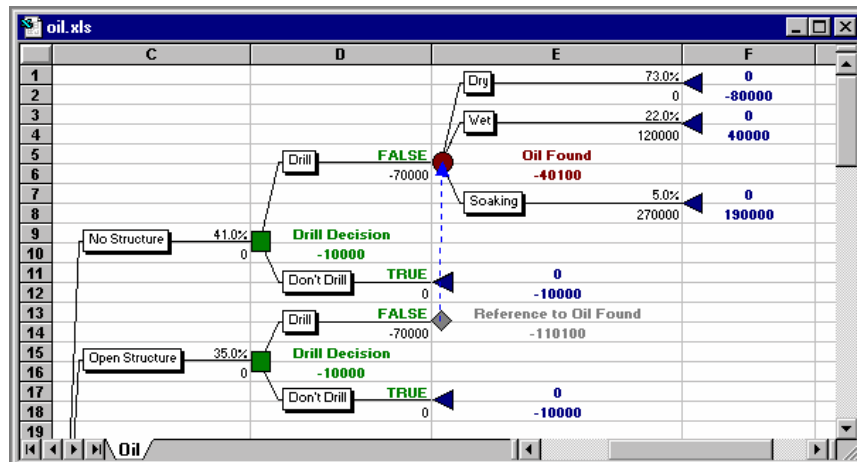

In this example, the sub-tree Oil Found (which follows the *Test\No Structure\Drill* path) is referenced at the end of the *Test\Open Structure\Drill* path. The dashed line shown displays the reference node link..

### ***Collapsing, Expanding and Reducing Trees***

Because decision trees can grow large as more nodes and decision options are added, it is important to be able to collapse sections of trees so important areas can be highlighted. Any node in PrecisionTree can be collapsed, hiding all successor nodes and branches. Collapsed sections are still calculated as are visible parts of the tree – they are just hidden from view.

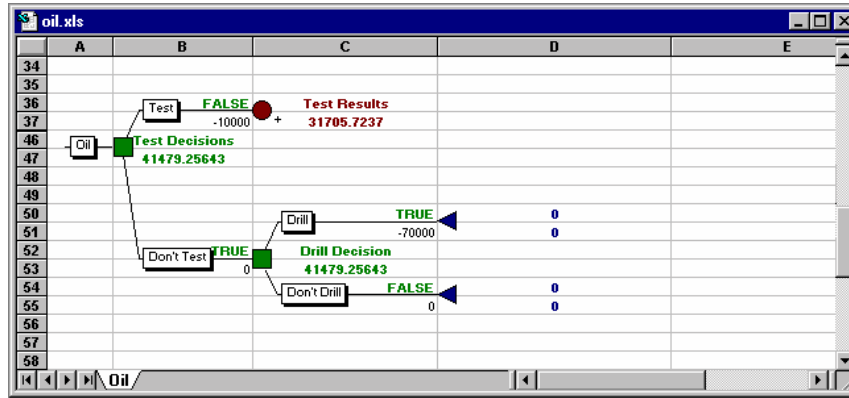

Clicking the small + symbol next to a collapsed node expands the node and all successor nodes and branches back to normal size.

Other features in PrecisionTree that are useful in keeping decision trees at a manageable size are:

- ◆ *Zooming to expand a selected section of a tree*
- ◆ *Reference nodes and subtrees*

---

# Chapter 4: Modeling Techniques

Introduction ..... 83

Attaching a Decision Tree to An Existing Excel Model..... 85

Generating Branch and End Node Payoffs with Formulas..... 89

Conducting a Sensitivity Analysis on Probabilities ..... 91



# Introduction

This chapter demonstrates the process of translating typical decisions into PrecisionTree models. These situations have been identified from real-life modeling problems that decision makers often encounter. As you model decisions, look through the examples and illustrations provided in this chapter.

You may find some helpful tips or techniques to make your PrecisionTree models the best representations of your decisions.

Several PrecisionTree techniques are presented here to illustrate common decision modeling situations. To help you understand the modeling techniques employed, example Excel worksheets are provided on disk with your PrecisionTree system. The analyses are even "pre-run" so if you like you can just look at the results. As you work through each modeling technique discussed, look at the corresponding worksheet. It will help you understand the PrecisionTree concepts and techniques involved in modeling each situation.

***The example models mentioned in this chapter can be found in the PrecisionTree\EXAMPLES directory.***



# Attaching a Decision Tree to An Existing Excel Model

## Using Standard Spreadsheets

A decision tree is often built in conjunction with a detailed spreadsheet model that calculates the financial results of each decision option. The decision tree is good for displaying your possible options, but usually a standard spreadsheet model is better for calculating the numeric results of each option. Integrating these two formats is key to an effective decision analysis.

### ***A Payoff from Each Possible Sequence of Events***

A decision tree defines all possible decision options and chance outcomes. In a tree, each possible sequence of events is represented as a path through the tree. At the end of each path is a payoff, or the value received if the sequence of events takes place. Many times, however, this payoff is best calculated by a model in traditional row and column spreadsheet format. This payoff model uses the values from the branches in the tree. But then it combines these values, along with other non-changing values, using Excel formulas to generate a result or payoff. In PrecisionTree, this linking of a decision tree to a payoff model is called a “linked tree”.

### ***Example Model: OIL\_LINK.XLS***

A linked tree allows you to easily combine a decision tree with a standard Excel model. By using linked trees you combine the strength of the decision tree for illustrating sequences of possible options with the strength of the traditional spreadsheet model for calculating results. To examine a linked tree in action, open the model OIL\_LINK.XLS located in the PTREE\EXAMPLES directory.

The model OIL\_LINK shows the standard oil drilling model described in *Chapter 4: An Overview to PrecisionTree* as a linked tree. A small Excel model is used to calculate the economic results from the oil drilling project. The branch values from the decision tree are linked to this Excel model to calculate payoffs at the end nodes for the tree.

## Linking Branch Values and End Node Payoffs

	A	B	C	D	E	F
1	<i>PrecisionTree's Linked Trees: An Example</i>					
3	Oil Prospect Economics					
4	Year	1997	1998	1999	2000	2001
5	Testing Costs	10000	0	0	0	0
6	Drilling Costs	70000	0	0	0	0
7	Oil Found (in BBL)	270000	0	0	0	0
8	Oil Production	0	54000	40004.18392	34431.92019	29635.82835
9	Price of Oil	20	20	20	20	20
10	Operating Expense	35000	35000	35000	35000	35000
11	Gross Profit	-115000	1045000	785083.6783	653638.4038	557716.567
12	Taxes	0	480700	351938.492	300673.6657	256549.6208
13	Net Profit	-115000	564300	413145.1863	352964.738	301166.9462
14						
15	NPV at 10%	\$1,100,300.92				
16	Total Production	270000				
17	Exponential Decline	0.15				
18						
19						
20						
21						
22						
23						
24						
25						
26						
27						
28						
29						

In the linked tree in OIL\_LINK, the default location for end node payoff values is cell B15, next to the label *NPV at 10%*. The Drill Decision decision node is linked to cell B6, *Drilling Costs*. The branch values from this node (70000 and 0) will be placed in cell B6 as PrecisionTree calculates the payoff values of paths through the tree which include these branches.

The screen shown here displays the calculation of the linked model for the path through the tree which terminates at the third end node from the top. This end node displays the value 1100300.92. This path represents the sequence of events, or the scenario, when:

- 1) A Test is performed
- 2) No Structure is found
- 3) A Well is drilled, and
- 4) Oil Found is soaking.



When using a linked model, each possible path through the decision tree represents one scenario and one recalculation of the linked model. For example, to calculate the payoffs for a decision tree with 500 end nodes (i.e., 500 possible paths through a tree), the linked model will be recalculated 500 times with 500 different sets of branch values. When calculating the value of a path across the tree, PrecisionTree:

- 1) *Inserts the value for each branch on the path into the cell or range specified for it.*
- 2) *Calculates the linked model (using the inserted values) to generate a new payoff value.*
- 3) *Returns this new payoff value at the end node for the path.*

#### **Tips for Using Linked Models**

When using linked models, it may help to keep the following points in mind:

- **Check Your Linked Models' Calculation for the Shortest Paths Through the Tree.** Some paths through a tree terminate sooner than others. For example, in OIL\_LINK.XLS, when a no drilling is performed, no values are placed in the linked model for Drilling Costs and Oil Found. This is because the Drilling Costs and Oil Found branches are not encountered when no drilling is performed.

Make sure that your linked model calculates properly in these situations (so that correct results are generated even though fewer values are linked). In OIL\_LINK, Drilling Costs and Oil Found are by default set to 0. This insures that short paths (such as those when no drilling is performed) calculate correctly.

- **Turn Automatically Update Links off for Large Trees.** The *Automatically Update Links* option in the *Tree Settings* dialog specifies whether or not PrecisionTree will automatically update end node payoffs in a linked tree each time the tree or linked model is edited. This option may be deselected when a large linked tree is being edited and the continued recalculations slow performance. When *Automatically Update Links* is turned off, click the *Update Links* icon on the PrecisionTree toolbar or the *Update Links Now* button in the *Tree Settings* dialog to force all end node payoffs to be updated.



# Generating Branch and End Node Payoffs with Formulas

## An Overview of Payoff Formulas

### **Example Model: OIL\_FORM.XLS**

When you create a new unlinked tree PrecisionTree by default uses the branch values shown in your spreadsheet to calculate end node payoffs. For example, when a value of 100 is entered in the spreadsheet for a branch value, PrecisionTree will add 100 to the value of any path through the tree which includes the branch. This is the *Cumulative* method for payoff calculation specified in the Tree Settings dialog box. Payoffs may also be calculated using payoff formulas for both the branch and end node payoffs. The *Formula* method for payoff calculation specified in the Tree Settings dialog box is used when payoff formulas are entered to calculate end node payoffs.

### **Branch Payoff Formulas**

There are cases when you wish to display one set of branch values in the spreadsheet but use different values from the branches in payoff calculations. You could set up a linked model to combine all the branch values in the tree to generate a payoff value. However, you may just wish to enter a formula for the node that converts the branch values for the node to a monetary measure.

Imagine, for example, that there are three branches from a chance node named *Daily Oil Well Production*, with the values 1000 barrels/day, 2000 barrels/day and 3000 barrels/day displayed in the tree. These branch values make clear what the possible outcomes are from the node and are measured in units - *barrels/day* - that are most relevant to the node. What is used for payoff calculations, however, should be a monetary value. This value can be calculated using a payoff formula for the node.

The standard oil drilling model has been modified to use payoff formula in the example OIL\_FORM.XLS. The last node, Oil Found, shows three branch values of 0, 6000 bbl and 15000 bbl. These values, however, need to be converted into dollars for use in the end node payoff calculations.

### **A Simple Payoff Formula for a Node**

In this case, a simple payoff formula:

**BranchVal\*18.50**

where 18.50 is the price of oil barrels, would convert the displayed branch values to monetary units.

To view the entered payoff formula:

- 1) Click on an *Oil Found* node in *OIL\_FORM.XLS*. The *Node Settings* dialog box is displayed.
- 2) Click the *Branch Definition* button. The *Payoff Formula* is shown in the *Payoff Calculation* section.

**Tip: To keep the values for a node's branches out of payoff calculations entirely, select *Ignore Branch Values in the Cumulative Payoff Calculation* method.**

**Referring to  
Branch Values  
in Other  
Formulas**

Even though a branch value is not directly used in payoff calculations, it still may be referenced by any other formula in the spreadsheet and included in formulas which calculate the value for other branches. In *OIL\_FORM.XLS*, for example, a chance node named *Oil Revenues* is added after the *Oil Found* node. This chance node has three branches, *Low*, *Medium* and *High*. The formulas in the cells where the *Oil Revenue* branch values are shown reference the cell where each *Oil Found* branch value is displayed.

**End Node  
Payoff Formula**

The *Payoff Formula* method for payoff calculation allows end node payoff values to be calculated using a formula. This formula can reference the values and probabilities for branches on the path whose payoff is being calculated. A typical payoff formula would be:

$=\text{BranchVal}(\text{"Price"}) * \text{BranchVal}(\text{"Sales Volume"}) - \text{BranchVal}(\text{"Costs"})$

When a payoff for a path is calculated using this formula, the value for the branch on the path from the node *Price* is multiplied by the value for the branch on the path from the node *Sales Volume*. Then, the value for the branch on the path from the node *Cost* is subtracted from the *Price \* Sales Volume* value to give the payoff for the path.

A default payoff formula is entered in the *Tree Settings* dialog box. This formula is automatically applied to each end node in the tree. By clicking on an end node, however, the payoff formula for a specific path may be edited or changed as necessary.

Two functions may be used in a payoff formula (in addition to any standard Excel function, operator or cell reference):

**BranchVal("node name")**, which returns the value of the branch of node name which was followed on the path.

**BranchProb("node name")**, which returns the probability of the branch of node name which was followed on the path.

# Conducting a Sensitivity Analysis on Probabilities

## Results from Changing Probabilities

**Example Model:**  
**PROBSENS.XLS**

A sensitivity analysis where the variable is the probability of a chance event is called probabilistic sensitivity analysis. This type of analysis shows you how uncertainty in the branch probabilities of a chance node affects the outcome of the model.

In PrecisionTree, as in most decision models, the sum of all branch probabilities of a node must equal 1. When you use constant values, it's easy to make sure that all values add up to 1. But what if one or more of the probabilities is a variable? Then you must take steps to insure that the probabilities remain valid as the variable changes. PrecisionTree “normalizes” the probability values so they add up to 1, but that may produce undesirable results.

**Defining  
Probability  
Values**

In general, you need to establish some sort of relationship between the probabilities. If there are only two branches, just define the second probability as 1 minus the first probability and make sure that the first probability always falls between 0 and 1.

**Relationship  
Between Two  
Branch  
Probabilities**

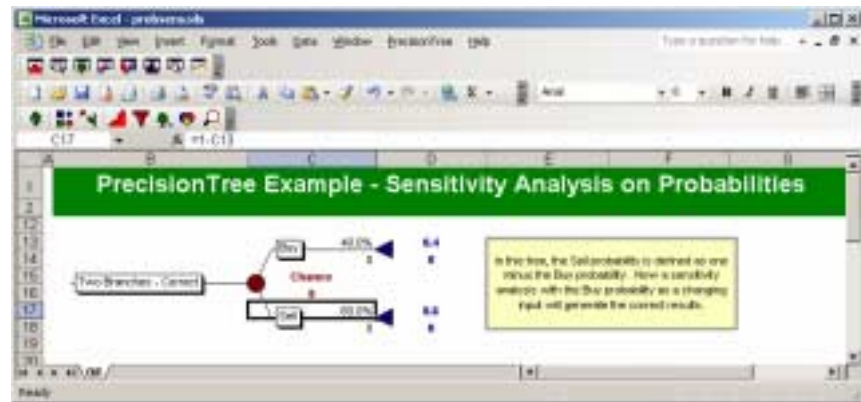

In this example, cell C13 could be varied between 0 and 1 in a sensitivity analysis. The second probability expression is always valid.

If there are three or more branches, simply define the probability of one branch as 1 minus the sum of the probabilities of all other branches, and make sure that the sum always falls between 0 and 1.

**Relationship  
Between Three  
Branch  
Probabilities**

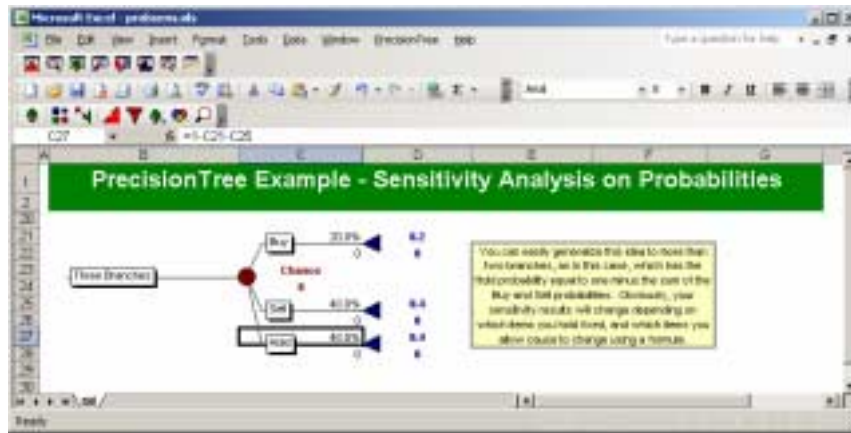

In this example, you could run a sensitivity analysis on cell C21 or cell C25. If the value of cell C25 remains 0.4, cell C21 should always fall between 0.0 and 0.6. If cell C21 were to remain constant, cell C25 could be varied between 0.0 and 0.8. These bounds insure that the third probability expression always falls between 0.0 and 1.0.

Another easy method is to define all probabilities in terms of a variable in a named range (called "Stock\_Prob" here), again making sure that the probabilities always add up to 1.

**Probabilities  
Defined by a  
Named Range**

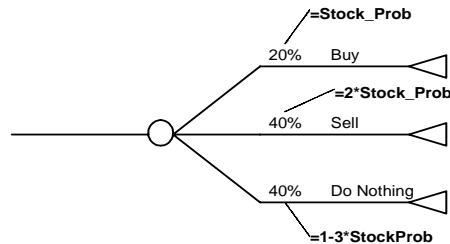

In this example, "Stock\_Prob" should always fall between 0 and 1/3. If it is less than 0, the first two probability expression are less than 0 and the last probability expression is greater than 0. If "Stock\_Prob" is greater than 1/3 then the last probability expression is less than 0. Therefore, to run a sensitivity analysis on "Stock\_Prob," choose 0.0 as the Minimum and 0.33 as the Maximum.

If you want to perform a probabilistic sensitivity analysis, you should verify that your probabilities sum to 1 when the variable changes. Although PrecisionTree does normalize the values when they do not sum to 1, that may produce undesirable or nonsensical results when an analysis is run.

---

# Chapter 5: PrecisionTree Command Reference

<b>Introduction .....</b>	<b>95</b>
How Toolbar Descriptions are Organized.....	95
How Command Descriptions are Organized.....	95
<b>PrecisionTree Toolbar Icons .....</b>	<b>97</b>
<b>PrecisionTree Menu.....</b>	<b>99</b>
<b>Create New Submenu - Tree Command .....</b>	<b>100</b>
<b>Create New Submenu - Influence Diagram or Node Command ....</b>	<b>101</b>
<b>Create New Influence Arc Icon .....</b>	<b>102</b>
<b>Settings Command .....</b>	<b>103</b>
<b>Settings Command - Decision Tree Option .....</b>	<b>104</b>
Delete Tree.....	104
Tree Name .....	104
Optimum Path.....	104
Utility Function .....	105
Payoff Calculation .....	106
@RISK .....	107
<b>Settings Command - Decision Tree Node Option .....</b>	<b>110</b>
Copy and Paste .....	110
Collapse and Expand .....	111
Node Type .....	111
Name .....	111
# of Branches .....	111
Reference.....	112
Link Branch Values To, Link Payoff Values From .....	112
Branch Definition.....	113
<b>Settings Command - Decision Tree Branch Option .....</b>	<b>117</b>

<b>Settings Command - Influence Diagram Option .....</b>	<b>118</b>
Delete .....	118
Diagram Name .....	118
Optimum Path .....	119
Utility Function .....	119
Conversion to Decision Tree .....	119
@RISK .....	119
<b>Settings Command - Influence Diagram Node Option .....</b>	<b>120</b>
Node Type .....	120
Name .....	121
Outcomes - Up, Down, Delete, Add .....	121
Standard Size .....	121
Delete .....	121
Values .....	121
<b>Settings Command - Influence Diagram Arc Option.....</b>	<b>123</b>
Type of Influence .....	124
<b>Decision Analysis Command .....</b>	<b>126</b>
Statistics Report .....	126
Risk Profile .....	127
Cumulative Risk Profile .....	127
Policy Suggestions .....	128
<b>Sensitivity Analysis Command .....</b>	<b>129</b>
Cell to Analyze .....	129
Analysis Type .....	130
Update Display .....	130
Cells to Vary .....	130
Results of a One-Way Sensitivity Analysis.....	131
Results of a Two-Way Sensitivity Analysis.....	135
<b>Graph Options Command.....</b>	<b>136</b>
<b>Zoom Selection Command.....</b>	<b>137</b>
<b>Update Links Command .....</b>	<b>137</b>
<b>Contents Command .....</b>	<b>138</b>
<b>Authorization Command.....</b>	<b>138</b>
<b>About Command.....</b>	<b>138</b>



# Introduction

When the PrecisionTree add-in is loaded, a new toolbar and menu are created in Excel. This chapter details the available commands as they appear in the PrecisionTree menu. The PrecisionTree toolbar icons can be used to perform many of the available commands. The *PrecisionTree Icon Reference* section of this chapter gives the command equivalents for each PrecisionTree toolbar icon.

## How Toolbar Descriptions are Organized

Toolbar icons are displayed as they appear in the PrecisionTree toolbar. The following information is provided for each toolbar icon:

- ◆ *Picture of icon*
- ◆ *Description of command*
- ◆ *Equivalent menu command*

## How Command Descriptions are Organized

Command descriptions are listed as they appear in the PrecisionTree menu. The following information (where applicable) is provided for each command:



- ◆ *Description of command*
- ◆ *Equivalent toolbar icon*
- ◆ *Description of dialog boxes that appear*
- ◆ *Explanation of input boxes, options and command buttons included in dialog boxes*



# PrecisionTree Toolbar Icons

PrecisionTree icons are used to quickly and easily perform tasks necessary to set up and run decision analyses. PrecisionTree icons appear in a new Excel toolbar. This section briefly describes each icon, outlining the functions they perform and the menu command equivalents for the icon. All of the commands may be found in the PrecisionTree menu on the Excel menu bar. A second toolbar titled *DecisionTools* is also available when PrecisionTree is installed. This toolbar contains icons which can be used to run PrecisionTree or any of the other programs in the DecisionTools suite (if these programs are installed on your system). For more information on the DecisionTools suite, see *Appendix D: Using PrecisionTree With Other DecisionTools*.

## **PrecisionTree Toolbar**

<b><u>Icon</u></b>	<b><u>Functions Performed and Command Equivalent</u></b>
	<b><i>Creates a new tree.</i></b> <i>Equivalent to the Create New submenu Tree command.</i>
	<b><i>Creates a new influence diagram or node.</i></b> <i>Equivalent to the Create New submenu Influence Diagram or Node command.</i>
	<b><i>Creates a new influence diagram arc.</i></b>
	<b><i>Displays current settings for a tree, node, arc or branch.</i></b> <i>Equivalent to the Settings command.</i>
	<b><i>Starts a decision analysis on a decision tree or influence diagram.</i></b> <i>Equivalent to the Analysis submenu Decision Analysis command.</i>
	<b><i>Starts a sensitivity analysis on a cell.</i></b> <i>Equivalent to the Analysis submenu Sensitivity Analysis command.</i>
	<b><i>Updates all payoff values for a linked decision tree or influence diagram.</i></b> <i>Equivalent to the Update Links command.</i>
	<b><i>Expands the selected portion of a decision tree or influence diagram in a new window.</i></b> <i>Equivalent to the Zoom command.</i>

**DecisionTools  
Toolbar**

**Icon**

**Functions Performed and Command  
Equivalent**



***Loads the @RISK add-in.***

*Equivalent to the @RISK command on the Excel Tools menu.*



***Loads the TopRank add-in.***

*Equivalent to the TopRank command on the Excel Tools menu.*



***Loads the PrecisionTree add-in.***

*Equivalent to the PrecisionTree command on the Excel Tools menu.*



***Runs the BestFit program.***

*Equivalent to the BestFit command on the Excel Tools menu.*



***Runs the RISKview program.***

*Equivalent to the RISKview command on the Excel Tools menu.*

# PrecisionTree Menu

Loading PrecisionTree creates a new toolbar and a new menu for designing decision trees and influence diagrams. The commands appear in a new menu labeled "PrecisionTree" which is added to the right of the existing menus displayed in the Excel menu bars.

Some of the icons on the PrecisionTree toolbar can be used to perform many of the commands described here. The section titled *PrecisionTree Toolbar Icons* provides the menu equivalents for each icon.

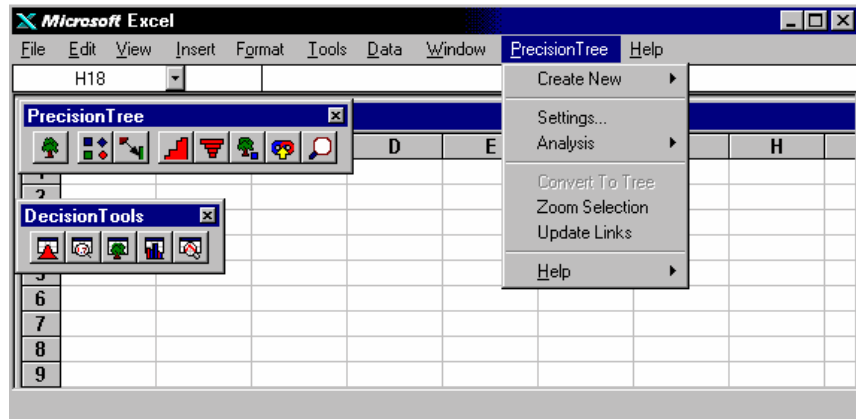

This section details the available commands as they appear in the PrecisionTree menu.

# Create New Submenu - Tree Command

---

**Creates a new tree on the active worksheet.**

---

The *Tree* command on the *Create New* submenu creates a new decision tree. After clicking the icon, a tree is started wherever the user clicks in the worksheet. A new tree has a default name of *Tree#n* (where *n* is the current number of trees in the active workbook) and a single branch terminating in an end node. To change either the name of a tree or its settings:

- ◆ *Click the box showing the tree name in your spreadsheet, or*
- ◆ *Click the Tree Settings icon or select the PrecisionTree menu Settings command and select the tree from the displayed list.*

# Create New Submenu - Influence Diagram or Node Command

---

**Creates a new influence diagram or node on the active worksheet.**

---



**Create New  
Influence  
Diagram or  
Node Icon**

The *Influence Diagram or Node* command on the *Create New* submenu creates a new influence diagram node. If there is no influence diagram in the current worksheet a new diagram is created as well. A new diagram has a default name of *Diagram#n* (where *n* is the current number of diagrams in the active workbook). A new node is created by dragging the cursor at the position in the worksheet where the new node is desired.

When a new influence diagram node is created, the *Influence Node Settings* dialog box is displayed, allowing you to select the type of node you wish to add, name it and its possible outcomes, and enter values and probabilities. For more information on this, see the *Node Settings - Influence Diagram* command in this chapter.

To change either the name of an entire diagram or its settings:

- ◆ *Click the box showing the diagram name in your spreadsheet, or*
- ◆ *Click the Settings icon or select the PrecisionTree menu Settings command and select the influence diagram from the displayed list.*

# Create New Influence Arc Icon

---

**Creates a new influence diagram arc on the active worksheet.**

---



**Create New  
Influence Arc  
Icon**

The *Create New Influence Arc* icon creates a new influence diagram arc between two nodes in the current influence diagram.

When a new influence diagram arc is created the *Influence Arc Settings* dialog box is displayed, allowing you to select the type of influence you wish to specify between the two nodes. For more information on this, see the *Node Settings - Influence Arcs* command in this chapter.



# Settings Command

---

**Displays the settings for the selected decision tree, influence diagram, node, branch or arc.**

---



**Settings Icon**

## **Displaying Settings By Selecting Items in a Worksheet**

The *Settings* command displays the current settings for the selected decision tree, influence diagram, decision tree node, decision tree branch, influence diagram node or influence diagram arc. The settings displayed depend on whether a decision tree, influence diagram, node, branch or arc is selected.

Settings can also be displayed by clicking on the text box containing the name of an item in a decision model in a worksheet. This is done as follows:

- For settings on a **decision tree**, click on the decision tree name shown at the root of the tree.
- For settings on an **influence diagram**, click on the influence diagram name shown at the top left of the worksheet which contains the diagram.
- For settings on **decision tree branch or influence diagram node**, click on the name of item in the decision tree or influence diagram.
- For settings on a **decision tree node or influence diagram arc**, click on the node or arc itself in the worksheet.

## **Settings Selection Dialog Box**

When the Settings icon is clicked or the PrecisionTree menu Settings command is selected, a dialog box is displayed that allows the selection of the model or model component for which settings are to be displayed. The *Type* option allows the selection of the type of model component for which settings are desired. The available options are *Models*, *Nodes and Arcs/Branches*. The dialog box displayed changes based on the model or model component selected, as shown in the example below. Clicking in a displayed list shows the settings for the selected item.

## **Settings Selection for Arcs and Branches**

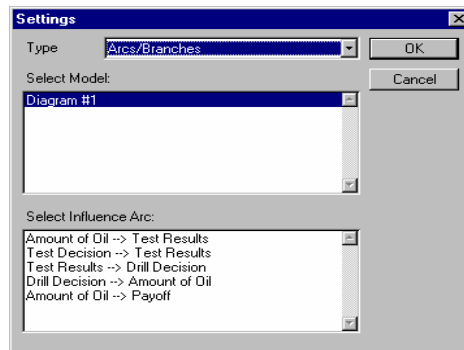

# Settings Command - Decision Tree Option

---

**Displays settings for the selected decision tree.**

---

The Decision Tree settings available include tree name, path selection, @RISK options, utility function specification and payoff calculation options.

## *Tree Settings Dialog Box*

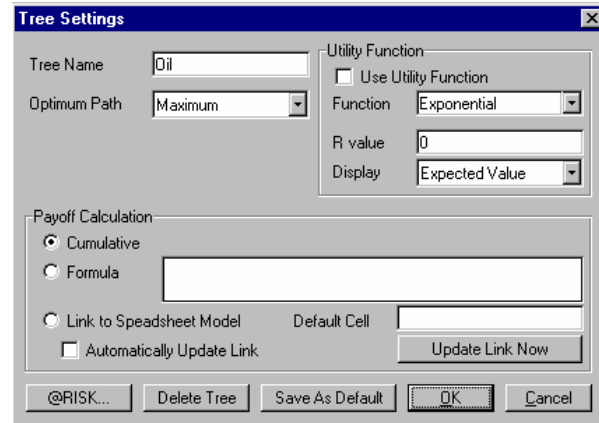

## Delete Tree

The *Delete Tree* button deletes the current tree.

## Tree Name

The *Tree Name* entry specifies the name that will be used to identify your decision tree in the spreadsheet. This name is also used when selecting a tree to analyze and for labelling reports and graphs.

## Optimum Path

The *Optimum Path* options specify the criteria PrecisionTree will use for selecting the optimum path at each node in the tree and whether decisions are forced to a specific branch.

Two options are available for selecting the optimum path at each decision node in a tree. If *Maximum* is selected, PrecisionTree will follow the path that has the highest expected value or expected utility at a decision node. If *Minimum* is selected, PrecisionTree will follow the path that has the lowest expected value from a decision node.

## Utility Function

The *Utility Function* options in the *Tree Settings* dialog box specify settings employed when utility functions are used in a decision model. A utility function converts a decision tree's monetary payoffs into a different measure – expected utilities. This is done to include a decision maker's attitude toward risk in a decision analysis.

Utility functions are used because an individual's attitude towards risk can change a decision from that which would be chosen if only expected values are considered. In other words, the optimum decision may not be the one that maximizes expected monetary value when risk is taken into account.

### **Using Utility Functions**

The utility function used, along with the entered R, or risk coefficient, describes the decision maker's attitude toward risk. In PrecisionTree, a utility function is selected on a tree-specific basis. For each tree, you may select a unique utility function and R coefficient.

PrecisionTree includes a predefined Exponential and Logarithmic utility function for your use. You can even define your own utility function using Excel's built-in programming language, VBA (Visual Basic for Applications). Once a utility function is selected, optimum paths in a decision tree will be selected using certainty equivalents instead of expected values.

To apply a utility function to a decision tree's calculations:

1. *Click the check box Use Utility Function*
2. *Select an available Utility Function from the dropdown list or type in the name of your own custom utility function*
3. *Enter the R coefficient desired for the selected utility function*

### **Defining Your Own Utility Function**

PrecisionTree will recognize any public VBA function present in an open Excel file whose name starts with UTILITY\_ as a valid user-defined utility function. For example, the function UTILITY\_SQUAREROOT would be a valid utility function name. A second function whose name begins with INVERSE\_, such as INVERSE\_SQUAREROOT, must also be supplied. If you have defined a custom utility function, simply enter its name in the drop down list. For more information on defining your own utility functions, see the section *Custom Utility Functions* in *Appendix B: Utility Functions*.

***Note: For more information on utility functions, see Appendix B: Utility Functions.***

## Payoff Calculation

The Payoff Calculation options select the method to be used for calculating payoff values in the current decision tree. Three options are available for payoff calculation – *Cumulative*, *Payoff Formula* and *Link to Spreadsheet Model*.

### **Cumulative**

The Cumulative method for payoff calculation is the simplest method for calculating the payoff values for each path through a decision tree. With the cumulative method, values for each branch on a path through a tree are simply added up in order to calculate the payoff value shown at the end node for the path. The branch values used can be modified with the *Cumulative Payoff Calculation* options in the *Branch Definition* dialog box for each node. For more information on these options, see *Branch Definition* in the *Settings Command - Decision Tree Node Option* in this chapter.

### **Payoff Formula**

The Payoff Formula method for payoff calculation allows end node payoff values to be calculated using a formula. This formula can reference the values and probabilities for branches on the path whose payoff is being calculated. A typical payoff formula would be:

`=BranchVal("Price")*BranchVal("Sales Volume")-BranchVal("Costs")`

When a payoff for a path is calculated using this formula, the value for the branch on the path from the node *Price* is multiplied by the value for the branch on the path from the node *Sales Volume*. Then, the value for the branch on the path from the node *Cost* is subtracted from the *Price \* Sales Volume* value to give the payoff for the path.

A default payoff formula is entered in the Tree Settings dialog box. This formula is automatically applied to each end node in the tree. By clicking on an end node, however, the payoff formula for a specific path may be edited or changed as necessary.

Two functions may be used in a payoff formula (in addition to any standard Excel function, operator or cell reference):

**BranchVal("node name")**, which returns the value of the branch of node name which was followed on the path.

**BranchProb("node name")**, which returns the probability of the branch of node name which was followed on the path.

### **Link to Spreadsheet Model**

The *Link to Spreadsheet Model* method for payoff calculation allows both branch and payoff values in a decision tree to be linked to cells in a Excel model that is external to the tree. By linking values, end node payoffs can be calculated by a detailed spreadsheet model.

In a linked tree, each node can be linked to an Excel cell reference or range name. When a linked tree is recalculated, branch values on each

path in the tree are substituted into the designated cells in the Excel model and the payoff is calculated. End node payoffs are then taken from the cell specified as the location of the payoff value.

For linked trees, two additional linked model settings are available – *Automatically Update Links* and *Default Cell*.

### **Automatically Update Links**

*Automatically Update Links* specifies whether or not PrecisionTree will automatically update end node payoffs in a linked tree each time the tree or linked model is edited. This option may be deselected when a large linked tree is being edited and the continued recalculations slow performance. When *Automatically Update Links* is turned off, click the *Update Links* icon on the PrecisionTree toolbar or the *Update Links Now* button to force all end node payoffs to be updated.

### **Default Cell**

A default payoff cell reference or range name may be specified. This cell reference will initially be used for all newly created end nodes in the decision tree. The default payoff reference may be changed on an end-node specific basis when payoffs should be read in from a different cell.

## **@RISK**

The @RISK options control how @RISK will recalculate during a Monte Carlo simulation of a decision tree or influence diagram. Two sets of options are available affecting 1) the type of recalculation performed each iteration of the simulation and 2) how decisions can change during a simulation.

### **@RISK Dialog Box**

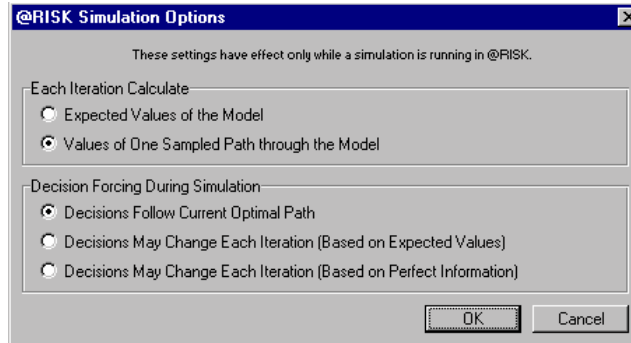

### **Each Iteration Calculate**

Two options are available for recalculation during a simulation performed with @RISK. The first option, *Expected Values of the Model*, causes @RISK to sample all distribution functions in the model and supporting spreadsheets each iteration. Then, the model is recalculated using the new sampled values to generate new expected values. Typically the output from the simulation is the cell containing the expected value of the model. At the end of the run an output distribution which reflects the range of possible expected values for the model and their relative likelihood of occurrence is generated.

The second option, *Values of One Sampled Path Through the Model*, causes @RISK to randomly sample a path through the model each iteration of a simulation. The branch to follow from each chance node is randomly selected based on the branch probabilities entered. This method does not require that distribution functions be present in the model; however, if they are used, new samples are returned each iteration and used in path value calculations. The output from the simulation is the cell containing the value of the model, such as the value of the root node of a decision tree. At the end of the run an output distribution reflecting the range of possible output values for the model and their relative likelihood of occurrence is generated.

### **Decision Forcing During Simulation**

*Decision Forcing During Simulation* options "force" PrecisionTree to select a specific branch from a decision node each iteration of a simulation, overriding any path selection based upon the entered *Optimum Path* option. This keeps the optimum path for a decision node from changing when values for uncertain chance events which follow the node change during the simulation. Forced decisions keep the path selected from decision nodes exactly the same as was identified when the tree was analyzed using expected values.

Forced decisions can also be entered on a node-specific basis by using the *Forced Branch* option in the *Branch Definition* dialog. This would be done if you wanted to analyze a tree when a specific, and not necessarily optimal, decision is made at a specific node.

Three options are available for *Decision Forcing During Simulation*:

- *Decisions Follow Current Optimal Path* specifies that all decision nodes follow the path selected when the decision tree is calculated using expected values. Each iteration of a simulation the optimal decision for each decision node will not change.
- *Decisions May Change Each Iteration (Based on Expected Values)* allows all decision nodes in the simulated tree to follow, each iteration, the optimum path as determined using the expected values that were calculated in that iteration. This calculation first finds the expected values of all chance nodes using the samples that were returned for distribution functions in that iteration. A path or branch is selected from each decision node using these chance node expected values.

- *Decisions May Change Each Iteration (Based on Perfect Information)* allows all decision nodes in the simulated tree to follow the currently identified optimum path based on the value of branches selected from chance nodes. That is, a path or branch is selected from each decision node using the values of the branches selected for each chance node that follows the node. This allows decisions to change based on outcomes for uncertain future events; an occurrence that could never take place. However, the option *Decisions May Change Each Iteration (Based on Perfect Information)* lets you calculate the Value of Perfect Information; that is, the value of your model if you knew perfectly what was going to occur in the future.

**Note: The *Decisions May Change Each Iteration (Based on Perfect Information)* option may only be used when the *Each Iteration Calculate* option is set to *Values of One Sampled Path Through the Model*.**

# Settings Command - Decision Tree Node Option

---

**Displays settings for the selected decision tree node.**

---

The *Node Settings* command displays the current definition for the selected decision tree node. The settings available include node name, number of branches, the cell reference to link branch values to (linked trees only), branch definitions for the node, and, for end nodes, a payoff formula. Branch definitions are added in a separate dialog box.

Some of the options for Node Settings can change depending on the type of node being defined.

## **Node Settings Dialog Box**

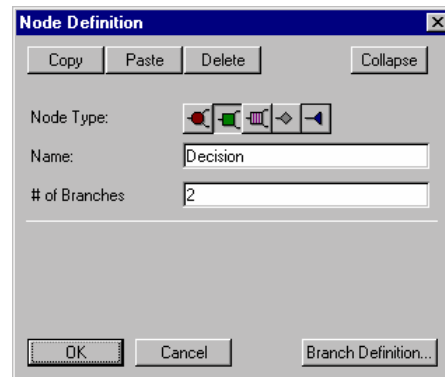

## **Copy and Paste**

The *Copy* and *Paste* buttons displayed at the top of the *Node Settings* dialog box may be used to copy a node (and all successor nodes and branches which follow the node) to a different location in a decision tree. Copied nodes replace a currently defined node when they are pasted on the node. To copy and paste a node:

- 1) *Display the Node Settings for the node you wish to copy*
- 2) *Click the Copy button*
- 3) *Display the Node Settings for the node you wish to overwrite with the copied node*
- 4) *Click Paste. The copied node, along with all successor nodes and branches which follow the copied node, will be added in the decision tree, replacing the previous node and its successors.*



## Collapse and Expand

The *Collapse* and *Expand* buttons allow you to collapse all branches and successor nodes that follow a node, or expand collapsed branches and nodes. Collapsed branches and successor nodes may also be expanded by clicking the + symbol shown next to a node.

## Node Type

The *Node Type* icon selection changes the type of node used for the current node. The five available node types are:

- Chance** - a red circle representing an event with a set of possible outcomes that the decision maker has no control over.
- Decision** - a green square representing an event where the decision maker must choose one of a number of options.
- Logic** - a purple square representing an event similar to a decision node, except that the decision chosen (i.e., the branch followed) is determined by a logical formula assigned to each option. (A logical formula in Excel, such as  $A10 > 1000$ , is a formula that returns either the value TRUE or FALSE.)
- Reference** - a grey diamond representing a link to a set of events described in a separate decision tree or a subtree in the current tree.
- End** - a blue triangle that represents the end point of a path through a decision tree.

A node's type may be changed at any time. Where applicable, branch values and probabilities will be retained when a node's type is changed.

## Name

The Name entry specifies the name that will be used to identify the node in the spreadsheet. This name can also be edited by typing the name directly in spreadsheet cell where the node name is displayed.

## # of Branches

The # of Branches entry specifies the number of branches for a decision, chance and logic node. End and reference nodes have no branches. The number of branches specified for a node can be increased at any time.

## Reference

For reference nodes, the *Reference* entry specifies the location of the tree or subtree that the node references. Two options are available for referencing trees -- *Other Tree* or *Node in Current Tree*. *Other Tree* refers to a unique decision tree with its own start node. *Node in Current Tree* is a subtree that begins at another node in the tree where the reference node is located. To enter a reference for a Reference node:

- 1) *Select the Other Tree or Node in Current Tree option*
- 2) *When Other Tree is selected, select a tree name from the drop down list.*
- 3) *When Node in Current Tree is selected, enter a cell reference by clicking on the cell containing the node's name or value.*

## Link Branch Values To, Link Payoff Values From

The *Link Branch Values To* and *Link Payoff Values From* options specify the cell reference to link with the current node in a linked decision tree. When a linked tree is created, nodes are linked to cell references in an Excel model. For all node types (except end nodes), the *Node Settings* dialog box displays the *Link Branch Values To* option. For end nodes, the *Node Settings* dialog box displays the *Link Payoff Values From* option.

### **How is Linking Performed?**

A linked tree calculates end node payoffs by placing branch values in designated locations in an Excel spreadsheet model. For branches from decision, chance and logic nodes, the branch values for the node are inserted in the cell specified with the *Link Branch Values To* option. For end nodes, the value calculated in the cell specified in the *Link Payoff Values From* option is returned by the end node.

When calculating the value of a path across the tree, PrecisionTree inserts the value for each branch on the path into the cell or range specified for it. A new payoff (using the inserted values) is then calculated by Excel. This payoff value is then returned by the end node for the path.

### **Link Branch Values To Option**

To link the branch values from a node to an Excel spreadsheet cell:

- 1) *Enter the Excel cell reference or range you wish to link the branch values of the node to. The cell reference or range can be on any open Excel workbook or worksheet.*

### **Link Payoff Values From Option**

To link an end node's payoff value to an Excel spreadsheet cell:

- 1) *Enter the Excel cell reference or range you wish to get the node's payoff value from. The cell reference or range can be on any open Excel workbook or worksheet.*

**Payoff Formula  
(End nodes  
only)**

The Payoff Formula calculation method allows end node payoff values to be calculated using a formula. This formula can reference the values and probabilities for branches on the path whose payoff is being calculated. A separate payoff formula can be entered for each end node in a decision tree. If no payoff is entered for an end node, the default payoff formula (entered in the *Tree Settings* dialog box) will be applied. For more information on payoff formulas, see *Payoff Formula* in the *Settings Command - Decision Tree option* in this chapter.

## Branch Definition

The *Branch Definition* settings are displayed when the *Branch Definition* button is clicked in the *Node Settings* dialog box. The *Branch Definition* dialog box allows you to change settings that describe all of the branches from the current node. These settings include *Branch Formulas*, *Cumulative Payoff Calculation* and *Forced Branch*.

**Branch  
Definition  
Dialog Box**

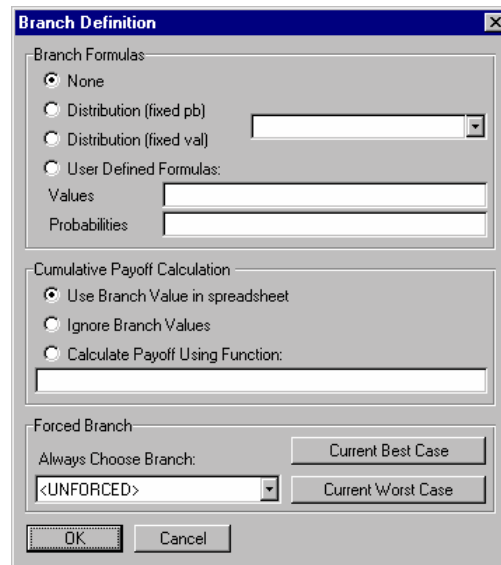

**Branch  
Formulas**

Branch formulas are used to calculate branch probabilities and/or values for all a node's branches. These probabilities and values can be calculated using a probability distribution ("a distributed chance node") or by using a formula you enter that is applied to all branches. There are four possible options for Branch Formulas - *None*, *Distributed Probabilities*, *Distributed Values* and *User Defined Formulas*.

**None**

By default, None is selected for Branch Formulas. In this case, PrecisionTree simply uses the values and probabilities that you type in the appropriate spreadsheet cells next to the branches.

***Distribution  
(Fixed Val)***

PrecisionTree can automatically determine branch probabilities for a chance node using a distribution function you specify. This is called a “Distributed Chance Node”. It is used when you want branch probabilities to follow the relative shape of the probabilities described by a continuous probability distribution.

The probability distribution you want to use to select probabilities for branches is selected in the dropdown distribution list on the right side of the dialog box. For each of the displayed distribution types, you enter a set of distribution arguments to define the distribution PrecisionTree will use to calculate branch probabilities.

This **Fixed Val** or fixed value option creates equally spaced “bins” across the maximum and minimum range of the distribution you specify. The number of bins is the number of branches originating from the chance node. It then calculates the probabilities associated with the midpoints of these bins, and normalizes them to unity. The midpoint “x” values become the chance node’s payoff values, while the normalized probabilities become the branch probabilities. If a distribution is asymptotic (in other words there is no finite minimum or maximum value) then the minimum value is where the cumulative distribution function reaches 1% and the maximum value is where the cumulative distribution reaches 99%.

***Distribution  
(Fixed Pb)***

PrecisionTree can automatically determine branch values using a distribution function you specify in the dropdown distribution list shown on the right side of the dialog box. For each of the displayed distribution types, you enter a set of distribution arguments to define the distribution PrecisionTree will use to calculate branch values.

This **Fixed Pb** or fixed probability option divides 100% by the number of branches to get the probability for each branch. To determine the corresponding values, the cumulative distribution function is divided into equally sized “bins” of probability. The value associated with each branch is the corresponding x-value of the midpoints of each of these bins.

**User Defined  
Formula**

A user defined formula can be used to quickly assign branch values and probabilities for all branches from the current node. The formula can be any standard Excel formula and can include any valid Excel function, cell reference or operator. In addition, custom keywords can be used to change the value the formula calculates by branch. For example, using the custom **BranchNum** entry (for a branch number), a formula can calculate a value that changes by branch. For example, the value formula:

**BranchNum\*1000**

would automatically enter the value of 1000 in the top branch from a node, 2000 in the second, 3000 in the third and so on.

**Cumulative  
Payoff  
Calculations**

In a decision tree that uses the Cumulative payoff calculation method (i.e., does not have a payoff formula and is not linked to a spreadsheet) three methods are available for using branch values in payoff calculations - *Use Branch Value in Spreadsheet*, *Ignore Branch Values*, and *Calculate Payoff Using Function*.

**Use Branch  
Value in  
Spreadsheet**

By default, the values for the branches from a node are taken directly from the spreadsheet when calculating the value of a path through a tree, i.e., the *Use Branch Value in Spreadsheet* option is selected. For example, when a value of 100 is entered in the spreadsheet for a branch value, PrecisionTree will add 100 to the value of any path through the tree which includes the branch.

**Ignore Branch  
Values**

Branch values for a node may be completely removed from cumulative payoff calculations by selecting the *Ignore Branch Values* option. This is done when you wish to display a set of branch values in your decision tree to help portray the different decision or chance options, but ignore these values during cumulative payoff calculations.

**Calculate Payoff  
Using Function**

In some cases you may wish to display a set of branch values in the spreadsheet but use different values in payoff calculations. This is done by entering a formula using the *Calculate Payoff Using Function* option. For example, there may be three branches from a chance node named *Daily Oil Well Production*, with the values 1000 barrels/day, 2000 barrels/day and 3000 barrels/day displayed in the spreadsheet. These branch values make clear what the possible outcomes are from the node and are measured in units that are most relevant to the node. What is used for payoff calculations, however, should be a monetary unit. In this case, a simple payoff formula:

**BranchVal\*18.50**

where 18.50 is the price of oil barrels, would convert the displayed branch values to monetary units.

**Custom  
Keywords  
Available for  
Branch and  
Payoff Formulas**

A set of custom keywords are available that can be embedded in formulas for branch value, probability and payoffs. Some of these keywords are only available for certain formulas. For example, the BranchVal keyword cannot be used in a formula which defines branch value. The available keywords include:

- ◆ **BranchNum** or the number of the branch for which the formula is being evaluated.
- ◆ **BranchVal** or the value of the branch for which the formula is being evaluated. (Branch Probability and Payoff Formula only)
- ◆ **BranchProb** or the probability of the branch for which the formula is being evaluated. (Branch Value and Payoff Formula only)
- ◆ **TotalBranches** or the total branch number of branches from the node

**Note: Any valid Excel formula notation can be used in a branch formula.**

**Forced Branch**

The Forced Branch options in the Branch Definition dialog box are used to force the branch to be followed for the current node only. A decision or chance node outcome can be forced to a specific branch or to the branch representing the best path or worst path. Use these options to conduct a decision analysis on a model when a specific (and not necessarily optimal) decision is made, or a specific chance node outcome occurs. To select a specific branch to force:

- ◆ Select the branch name in the list box, or
- ◆ Click best case or worst case, highlighting the best or worst case branch in branch name list box.

# Settings Command - Decision Tree Branch Option

---

**Displays settings for the selected decision tree branch.**

---

The Branch Settings dialog box is used to name, delete and reorder branches. This dialog box is displayed by clicking on a branch name or branch in a decision tree.

## **Branch Settings Dialog Box**

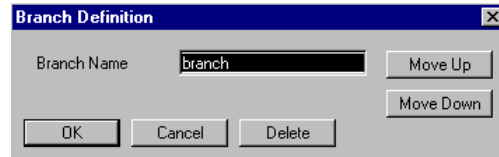

## **Deleting Branches**

To delete branches from a node:

- 1) *Click on the branch name you wish to delete. This name is located on top of the branch in the spreadsheet.*
- 2) *Click the Delete button. The branch, along with all successor nodes which follow the branch, will be deleted.*

## **Reordering Branches**

Branches may be reordered as new branches are added and branches are deleted. To reorder the existing branches from a node:

- 1) *Click on any branch name in the spreadsheet. The Branch Parameter dialog box appears, allowing you to name, delete or reorder a branch.*
- 2) *Use the Move Up and Move Down buttons to move the position of a branch.*

# Settings Command - Influence Diagram Option

---

Displays the settings for the selected influence diagram.

---

The *Settings* command displays the current settings for the selected influence diagram. The settings available include tree name, path selection, @RISK options, utility function specification and linked model setup.

## ***Influence Diagram Settings Dialog Box***

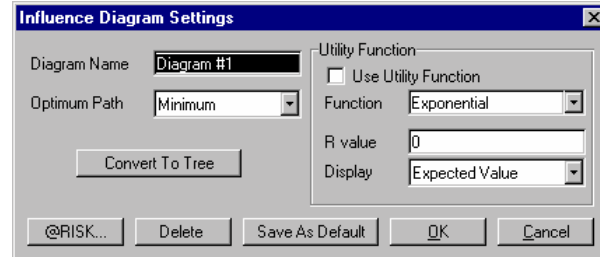

## **Delete**

The *Delete* button deletes the current tree.

## **Diagram Name**

The *Diagram Name* entry specifies the name that will be used to identify your influence diagram in the spreadsheet. This name is also used when selecting a diagram to analyze and for labelling reports and graphs.



## Optimum Path

The *Optimum Path* options specify the criteria PrecisionTree will use for selecting the optimum path at each node in the diagram and whether decisions are forced to a specific outcome. For more information on these options, see *Optimum Path* in the Settings command - Decision Tree option.

## Utility Function

The *Utility Function* options in the *Influence Diagram Settings* dialog box specify settings employed when utility functions are used in a decision model. A utility function converts an influence diagram's monetary payoffs into a different measure – expected utility. This is done to include a decision maker's attitude toward risk in a decision analysis. For more information on these options, see *Utility Function* in the Settings command - Decision Tree option.

## Conversion to Decision Tree

The *Convert to Decision Tree* button creates a decision tree from the current influence diagram. This can be used to check the model specified by an influence diagram to insure that the specified relationships and chronological ordering of nodes are correct. Conversion to a decision tree also shows the impacts of any Bayesian revisions made between nodes in the influence diagram.

Once a model described with an influence diagram is converted to decision tree, it may be further edited and enhanced in decision tree format. However, any edits made to the model in decision tree format will not be reflected in the original influence diagram.

## @RISK

The @RISK options control how @RISK will recalculate and force decisions during a Monte Carlo simulation of the influence diagram. For more information on the available @RISK options, see *Settings Command - Decision Tree Option* in this chapter.

# Settings Command - Influence Diagram Node Option

---

**Displays the settings for a selected influence diagram node.**

---

The *Node Settings* command displays the current definition for the selected influence diagram node. The settings available include node type, node name, number and names of outcomes, the cell reference to link outcome values to (linked diagrams only) and an option to display the value table for the node.

## Node Settings Dialog Box

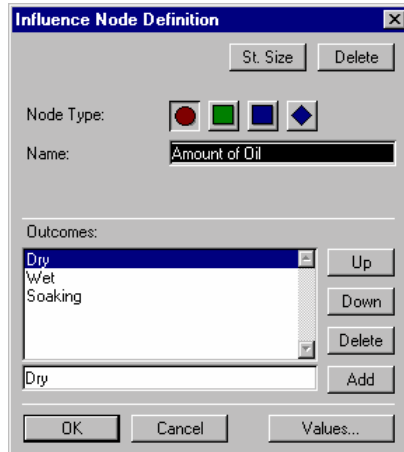

## Node Type

The *Node Type* icon selection changes the type of node used for the current influence diagram node. The four available node types are:

## Four Available Node Types

- Chance** - a red circle representing an event with a set of possible outcomes that the decision maker has no control over.
- Decision** - a green square representing an event where the decision maker must choose one of a number of options.
- Calculation** - a blue rounded rectangle representing a calculation that takes values from predecessor nodes and combines them using formulas to generate new values. There is no uncertainty or different options associated with a calculation node.
- Payoff** - a blue diamond representing the final payoff calculation or result from the model.

A node's type may be changed at any time. Where applicable, outcome names, values and probabilities will be retained when a node's type is changed.

## Name

The Name entry specifies the name that will be used to identify the node in the spreadsheet. This name can also be edited by typing the name directly in the node symbol where the node name is displayed.

## Outcomes - Up, Down, Delete, Add

The Outcomes options allow the entering, editing or deleting of the possible outcomes from an influence node. The name of an outcomes is entered in the text box below the outcome list. The text box displays the name of the outcome currently highlighted in the list. The *Up* and *Down* button are used to change the position of any outcome in the list. (Note: the position of outcomes in the list affects the relative location of the branches associated with the outcomes when an influence diagram is converted to a decision tree). The number of outcomes specified for a node can be changed at any time by clicking *Add* or *Delete*.

## Standard Size

The Standard Size button causes the current node to be displayed using the standard node size, regardless of the size it was drawn.

## Delete

The Delete button deletes the current node.

## Values

Clicking the Values button in an Influence Node dialog box displays the Value table for an influence diagram node. A Value table is used to enter the values for the possible outcomes for the node (and, for a chance node, probabilities of those outcomes). A value is entered for each possible combination of values of the predecessor, or influencing, nodes.

**Value Table for  
an Influence  
Diagram Node**

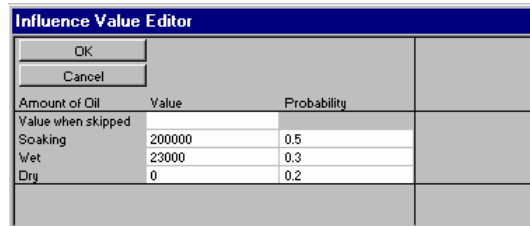

Amount of Oil	Value	Probability
Value when skipped		
Soaking	200000	0.5
Wet	23000	0.3
Dry	0	0.2

Value tables are standard Excel spreadsheets and can include values, formulas and cell references. Values and formulas can reference both other cells in the displayed value table (including the outcomes shown for predecessor cells) and other cells in open worksheets. Standard Excel commands for copying values and formulas can be used in a value table.

By entering a reference in a formula to a cell where an outcome's name is located, you are instructing PrecisionTree to use the values for the selected outcome when generating the appropriate value in the Value table.

***Note: Value table probability values for chance node outcomes do not have to sum to one. PrecisionTree normalizes entered probability values when calculating results from an influence diagram.***

### ***Value When Skipped***

The *Value When Skipped* entry specifies the value to use for the node in payoff calculations when the node is skipped due to the structure influence of arcs coming into the node. For example, in an influence diagram of an oil drilling model, the *Amount of Oil* node will be skipped when the outcome of the *Drill Decision* node is *Don't Drill*. In this case the *Value When Skipped* for *Amount of Oil* is 0, and 0 would be used in the payoff calculation formula *Amount of Oil-Cost of Testing-Cost of Drilling*. The *Value When Skipped* is in effect a "default" value for the node; in many cases, it is zero but it also may be non-zero if necessary.

# Settings Command - Influence Diagram Arc Option

---

**Displays the settings for a selected influence diagram arc.**

---

## **Arc Influence Types**

PrecisionTree offers three types of influence to be specified for an arc between nodes in an influence diagram - *value*, *timing* and *structure*. Clicking on an arc in an influence diagram allows you to specify the type of influence that the predecessor node has on the successor node.

## **Displaying Arc Influence Type in an Influence Diagram**

The type of influence selected is shown in the type of arc displayed in an influence diagram, as follows:

- *A solid black arc indicates a value influence, and a dashed line indicates that there is no value influence.*
- *A filled arrowhead indicates a timing influence, and a unfilled arrowhead indicates that there is no timing influence.*

A structure-only influence is shown by a dashed line (no value influence) with an unfilled arrowhead (no timing influence).

## **Arc Influence Dialog Box**

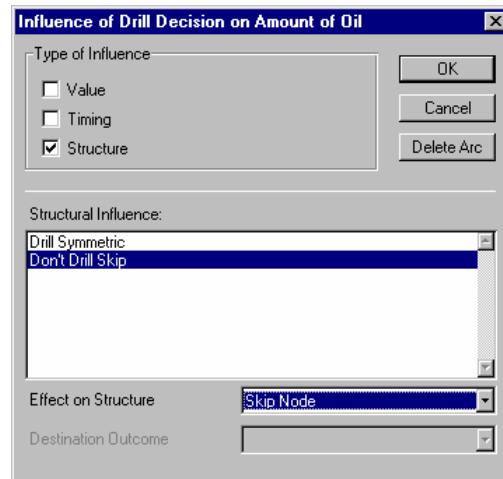

## Type of Influence

Three types of influence may be specified between nodes in an influence diagram - *Value, Timing, and Structure*. Depending on the type of node used for the predecessor node and successor node and the influence that exists between the nodes, you may be required to select multiple types of influence. For example, a chance node which influences the values of a decision node also must influence the timing of the decision node; that is, the chance event has to precede the decision.

### **Value Influence**

A Value influence specifies that the values for the successor node will be influenced by the possible outcomes for the predecessor node. If the successor node is a decision node, only values can be influenced; if it is a chance node, both values and probabilities can be influenced.

When a Value influence exists you enter different values for each successor node outcome at each predecessor node outcome. For example, examine the case where a predecessor chance node *Price* has two outcomes, *Low* and *High*. This node has a Value influence on a chance node *Sales Volume* that has three possible outcomes, *Low, Medium* and *High*. Because of the Value influence, at each *Sales Volume* outcome you will enter a value and probability at each of the two possible *Price* levels.

All arcs entering a calculation node must have a value influence. This is because a calculation node by definition combines the values of outcomes from predecessor nodes to calculate new values. No new outcomes or uncertainty are associated with calculation nodes.

### **Timing Influence**

A Timing influence specifies that the arc between two nodes in an influence diagram implies timing; that is, the predecessor node always occurs prior to the successor node in time. When a node has a Timing influence on another the predecessor node will be placed prior to (i.e., to the left) of the successor node in a decision tree created from the influence diagram.

### **Structure Influence**

Structure influence specifies that the structure of the outcomes of the successor node is affected by the outcome of the predecessor node. Structure influence is specified by outcome of the predecessor node, i.e. each possible outcome of the predecessor node can have an influence on the type of outcomes that occur for the successor node.

With a Structure influence, successor node outcomes can be forced or skipped depending on the outcome that occurs for the predecessor node. For example, in a *Price - Sales Volume* influence (where *Price* is the predecessor node and *Sales Volume* is the successor node), a *Low Price* may force the *High Sales Volume* outcome to occur.

Structure influence is used to convert influence diagrams into "asymmetric" decision trees, or trees where all the possible branches (as specified by all possible outcomes defined in the influence diagram) are not drawn. Asymmetric trees are quite common. The Oil Drilling example described in the chapter *Overview of PrecisionTree* is an asymmetric tree, as the decision *Not to Test*, followed by the decision *Not to Drill*, does not have the same node and branch structure as the section of the tree where the decision is made to *Test*.

### **Structure Influence Options**

The following types of structure influence can be specified for an outcome of the predecessor node on the outcomes of the successor node.

- **Symmetric** - this is the default where no structural influence is caused by the selected outcome of the predecessor node. If the selected outcome occurs and symmetric is selected, all outcomes of the successor node are possible. In a converted decision tree, all branches from the successor node will be shown when the path identified by the selected outcome is followed.
- **Skip Node** - indicates that all outcomes for the successor node should be skipped if the selected outcome occurs. In a converted decision tree, the successor node will not be included when the path identified by the selected outcome is followed.
- **Goto Payoff** - indicates that all subsequent nodes and outcomes will be eliminated if the selected outcome occurs. In a converted decision tree, the path identified by the selected outcome will terminate at an end node.
- **Force** - indicates that a specific outcome for the successor node will occur if the selected outcome for the predecessor node occurs. The outcome for the successor node is selected from the Destination Outcome entry at the bottom of the dialog box.
- **Eliminate** - indicates that a specific outcome for the successor node will be eliminated if the selected outcome for the predecessor node occurs. The outcome to eliminate from the successor node is selected from the Destination Outcome entry at the bottom of the dialog box.

# Decision Analysis Command

## Analysis Submenu

---

Performs a decision analysis on a decision tree.

---



**Decision  
Analysis Icon**

The *Decision Analysis* command runs a complete decision analysis on the selected decision tree or sub-tree. When the *Decision Analysis* command is selected or the *Decision Analysis* icon is clicked, a dialog box appears, prompting the user for the name of the tree to analyze or the name of the start node of the subtree to analyze.

Five reports and graphs – *Statistics* report, *Risk Profile* graph, *Cumulative Risk Profile* graph, *Scatter Profile* graph and *Policy Suggestion Report* – are generated by a decision analysis in PrecisionTree. These reports and graphs are created as standard Excel worksheets and charts and can be customized using any of Excel's formatting commands.

During an analysis, PrecisionTree determines every possible path value and the probability associated with each. These results are used to construct a distribution function called a risk profile.

### Statistics Report

The *Decision Analysis* command generates a statistical report after the analysis is run. The report displays general statistics for the decision model, including mean, standard deviation, etc.. If your tree begins with a decision node, PrecisionTree can analyze each possible decision from the node.

**Statistics Report  
in an Excel  
Worksheet**

	A	B	C	D	E
1	PrecisionTree Statistics Report				
2	For Oil of oil.xls				
3	Created on 7/11/2000 at 4:44:50 PM				
4					
5	Test Decision	1 : Test	2 : Don't Test		
6					
7	STATISTICS				
8	Mean	22587		20000	
9	Minimum	-80000		-70000	
10	Maximum	190000		200000	
11	Mode	-10000		-70000	
12	Std Dev	87715.43		103923	
13	Skewness	0.919699		0.721688	
14	Kurtosis	2.789759		2.083333	
15					
16	PROFILE:				
17	#	X	P	X	P
18	1	-80000	0.2009	-70000	0.5
19	2	-10000	0.41	50000	0.3
20	3	40000	0.2078	200000	0.2
21	4	190000	0.1813		



## Risk Profile

The Decision Analysis command generates a graph of the model's risk profile. The risk profile graph displays each possible end node payoff and the probability of each payoff occurring. Each line of the graph shows the probability that the payoff will equal a certain value. The expected value of the decision is also displayed. If your tree begins with a decision node, PrecisionTree analyzes each possible decision from the node and overlays the risk profile for each on the same graph.

**Risk Profile Graph**

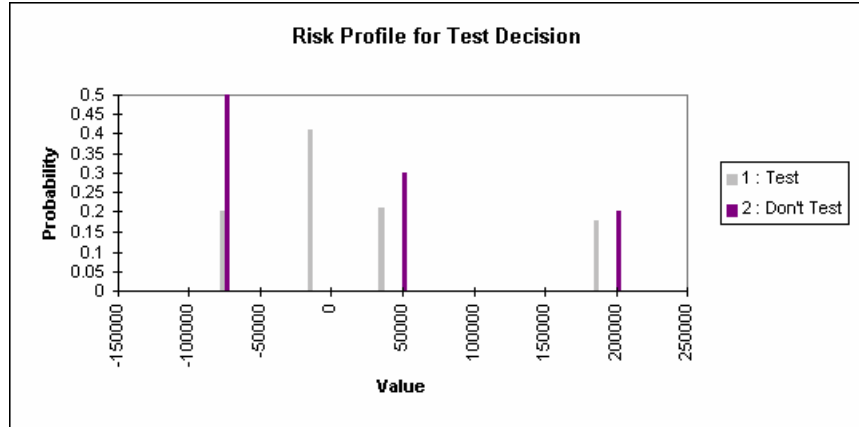

## Cumulative Risk Profile

The Decision Analysis command generates a graph of the model's cumulative risk profile. If your tree begins with a decision node, PrecisionTree creates cumulative risk profile for each possible decision from the node. This graph displays a cumulative distribution showing the probability of any payoff less than or equal to a certain value. The expected value of the decision is also displayed. The graph is created as an Excel chart and can be customized using any of Excel's chart formatting commands.

**Cumulative Risk Profile Graph**

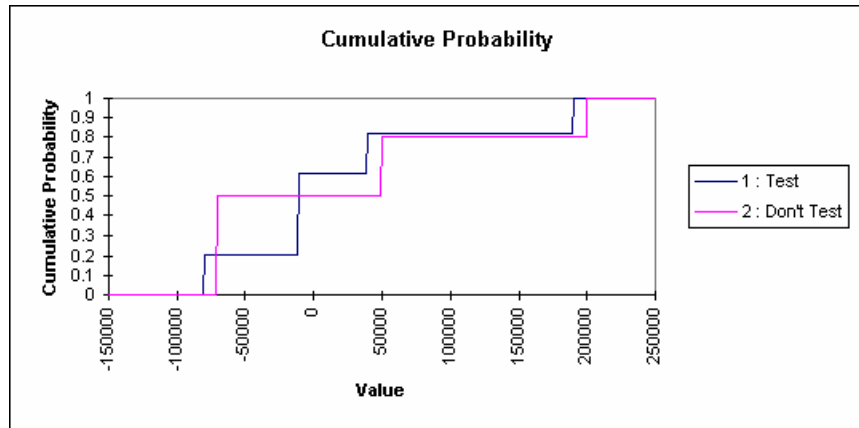



## Policy Suggestions

The Decision Analysis command in PrecisionTree Pro generates a policy suggestion for the selected model. This report shows what option was chosen at each node. The report, a reduced version of your tree, is drawn directly in your spreadsheet.

### Policy Suggestion Worksheet

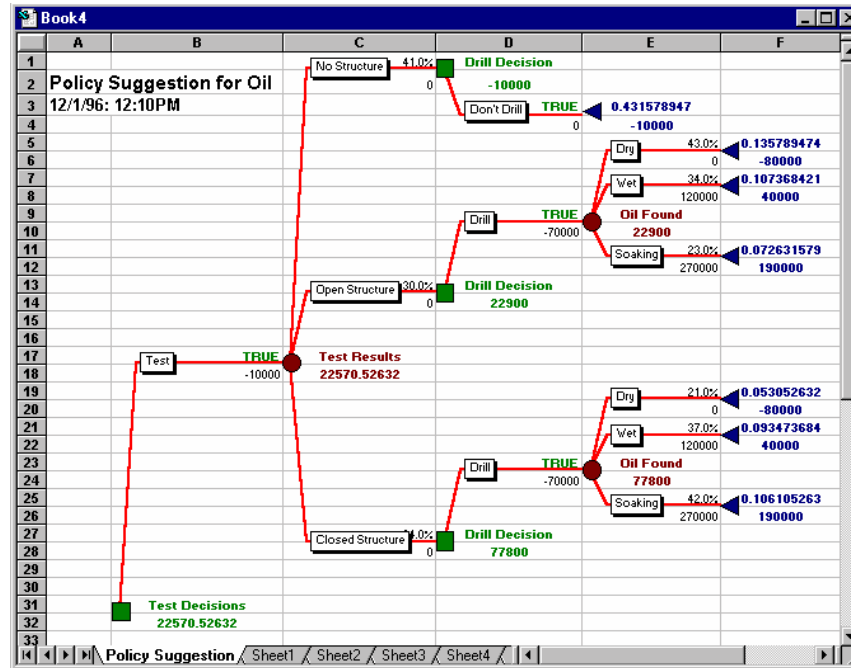

# Sensitivity Analysis Command

## Analysis Submenu

---

**Performs a sensitivity analysis on a decision model.**

---



**Sensitivity  
Analysis Icon**

The *Sensitivity Analysis* command runs a sensitivity analysis on a decision model. The goal of a sensitivity analysis is to identify which variables in your model have the most effect on your results. In a sensitivity analysis, the values in selected *Cells to Vary* are changed and the effect of that variation on the value of the *Cell to Analyze* is recorded. One cell may be varied at a time (a “one-way” sensitivity analysis) or two cells may be varied together (a “two-way” sensitivity analysis). The reports generated by a sensitivity analysis include tornado graphs, spider graphs and one-way and two-way sensitivity analysis graphs.

**Sensitivity  
Analysis Dialog  
Box**

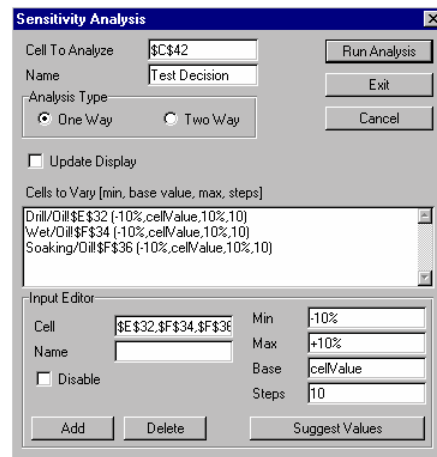

The screenshot shows the 'Sensitivity Analysis' dialog box. It has a title bar with a close button. The 'Cell To Analyze' field contains '\$C\$42'. The 'Name' field contains 'Test Decision'. There are three buttons: 'Run Analysis', 'Exit', and 'Cancel'. The 'Analysis Type' section has two radio buttons: 'One Way' (selected) and 'Two Way'. There is a checkbox for 'Update Display' which is unchecked. The 'Cells to Vary [min, base value, max, steps]' list contains three entries: 'Drill/Oil \$E\$32 (-10%, cellValue, 10%, 10)', 'Wet/Oil \$F\$34 (-10%, cellValue, 10%, 10)', and 'Soaking/Oil \$F\$36 (-10%, cellValue, 10%, 10)'. The 'Input Editor' section has a 'Cell' field with '\$E\$32,\$F\$34,\$F\$36', a 'Name' field, a 'Disable' checkbox, and fields for 'Min' (-10%), 'Max' (+10%), 'Base' (cellValue), and 'Steps' (10). There are 'Add', 'Delete', and 'Suggest Values' buttons at the bottom.

### Cell to Analyze

The *Cell to Analyze* entry specifies the cell in your decision tree or spreadsheet model that you want to analyze in a sensitivity analysis. This is the cell whose changes in value will be tracked as other values in the model are varied. If you want to analyze the value of an entire decision tree in a sensitivity analysis, select the value shown at the root of the tree as the *Cell to Analyze*.

## Analysis Type

The *Analysis Type* options specify the type of sensitivity analysis to be performed. A one-way or two-way sensitivity analysis can be run in PrecisionTree. In a one-way sensitivity analysis, one or more *Cells to Vary* are changed across their Minimum-Maximum range. For each new value tested for the *Cell to Vary*, a new value for the *Cell to Analyze* is calculated. In a two-way sensitivity analysis, two *Cells to Vary* are changed simultaneously and each possible combination of values for the two cells is tested. The effect of each combination on the *Cell to Analyze* is recorded.

## Update Display

*Update Display* turns the updating of the Excel display during sensitivity analysis on and off.

## Cells to Vary

The *Cells to Vary* section identifies the cell(s) to change in the sensitivity analysis and the values to test for those cells. Any number of *Cells to Vary* may be tested in a single sensitivity analysis. When a two-way sensitivity analysis is run, all possible pairs of the entered *Cells to Vary* are tested. For example, if four *Cells to Vary* are entered, six pairs of cells will be tested in a two-way sensitivity analysis.

<b>Cell</b>	The <i>Cell</i> entry specifies the references of the cells to vary in the current sensitivity analysis. Multiple cells may be selected in a single <i>Cells to Vary</i> entry by holding down the Ctrl key as multiple spreadsheet cells are highlighted. The displayed list shows all selected cells for the sensitivity analysis. By changing entries in the list, the minimum-maximum range for each entered <i>Cell to Vary</i> may be edited.
<b>Min</b>	The <i>Min</i> entry specifies the minimum value to use for the selected <i>Cells to Vary</i> . A minimum may be entered as an actual value (such as 100) or a percentage (such as -10%). When a percentage is entered, the minimum value to use is calculated by PrecisionTree by taking the specified percentage reduction in the base case or displayed value for the <i>Cell to Vary</i> . Percentages should be used when a single <i>Cells to Vary</i> entry has more than one cell specified.
<b>Max</b>	The <i>Max</i> entry specifies the maximum value to use for the selected <i>Cells to Vary</i> . As with the minimum entry, the maximum may be entered as an actual value (such as 100) or a percentage (such as -10%).
<b>Base</b>	The <i>Base</i> entry specifies the base value to use for the <i>Cell to Vary</i> . When a Min and Max percentage change is used, the change calculate is relative to the entered base value. This does not have to be the same value contained in the cell. The entry <i>cellValue</i> indicates that PrecisionTree will use whatever value is in the cell for the base value.

- Steps** The *Steps* entry specifies the number of steps or intervals to test across the entered minimum-maximum range for the selected *Cell to Vary*. During a sensitivity analysis, the entered minimum-maximum range is divided by the # of *Steps* entered and the *Cell to Vary* value at each step is calculated. This value is then placed in the *Cell to Vary* and a new value for the *Cell to Analyze* is calculated.
- Suggest Values** The *Suggest Values* button enters a default + and - change into the *Min*, *Max*, *Base* and # of *Steps* entries, based on the value currently contained in the *Cell to Vary*.
- Add** When the *Add* button is clicked, the information in the list of *Cells to Vary* is updated. If the *Cell to Vary* for which data (i.e., minimum, maximum, and # of *Steps*) has been entered is a current cell in the list, the data in the list for the cell is changed. If the *Cell to Vary* is not in the list, the cell and its data are added.
- Delete** The *Delete* button deletes the currently selected *Cells to Vary* from the list of cells to be included in the sensitivity analysis.
- Disable** Checking the *Disable* box removes the selected *Cell to Vary* from a sensitivity analysis, but leaves the cell in the list so it can be added back to an analysis at a later time. This is useful when running two-way sensitivity analyses so that the number of pairs of *Cells to Vary* tested in the analysis can be limited if desired.

## Results of a One-Way Sensitivity Analysis

When PrecisionTree runs a one-way sensitivity analysis, the following graphs and reports are generated:

### One-Way Sensitivity Graph

This graph is a simple line graph displaying values for the *Cell to Analyze* at each value tested for a *Cell to Vary*. A one-way sensitivity graph is generated for each *Cell to Vary* specified for the sensitivity analysis. The graph is created as an Excel chart and can be customized using any of Excel's chart formatting commands.

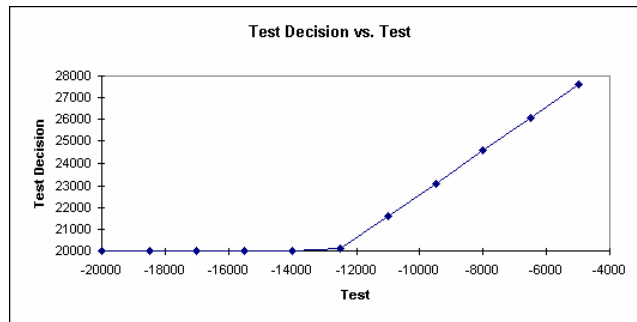

**One Way Strategy  
Region Graph**

A one-way strategy region graph displays the results of each possible initial decision at each value tested in a one-way sensitivity analysis (Pro version only). The *Cell to Analyze* must be the value of a decision node for this analysis to be performed.

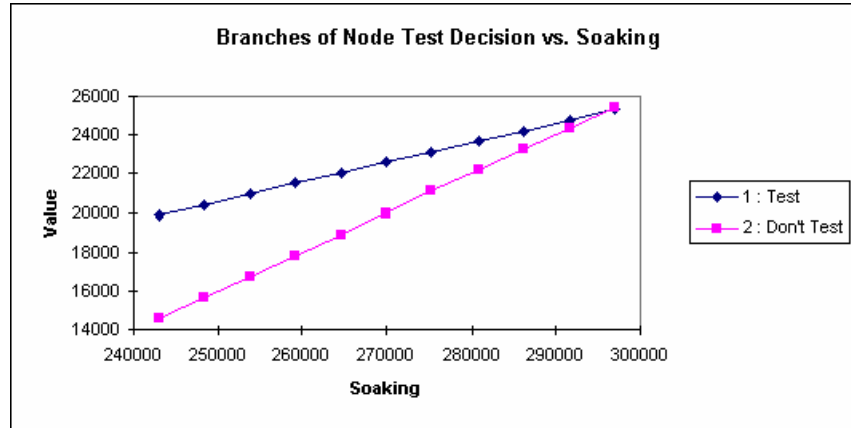

### **Tornado Graph**

A single Tornado graph is created for a one-way sensitivity analysis. This graph summarizes the effect of each *Cell to Vary* on the *Cell to Analyze*. A bar in the graph is created for each *Cell to Vary*. This bar shows the total change from the starting value of the *Cell to Analyze* which was caused by changing the *Cell to Vary*. The longer the bar, the greater the impact of the *Cell to Vary* on results, and thus the more significant that input is in your model. The diagram is created as an Excel chart and can be customized using any of Excel's chart formatting commands.

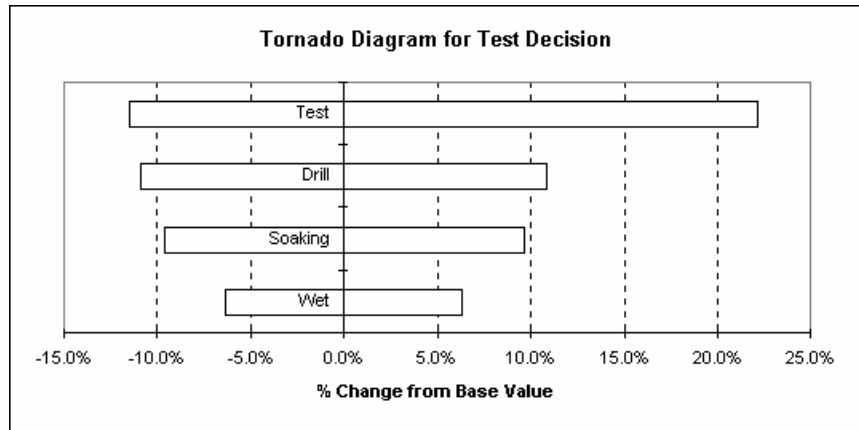

## Spider Graph

A single Spider graph is created for a one-way sensitivity analysis. This graph summarizes the effect of each *Cell to Vary* on the *Cell to Analyze*. A line in the graph is created for each *Cell to Vary*. This line shows the amount of change from the starting value of the *Cell to Analyze* which was caused by each value tested for the *Cell to Vary*. The steeper the line, the greater the impact of the *Cell to Vary* on results, and thus the more significant that input is in your model. The diagram is created as an Excel chart and can be customized using any of Excel's chart formatting commands.

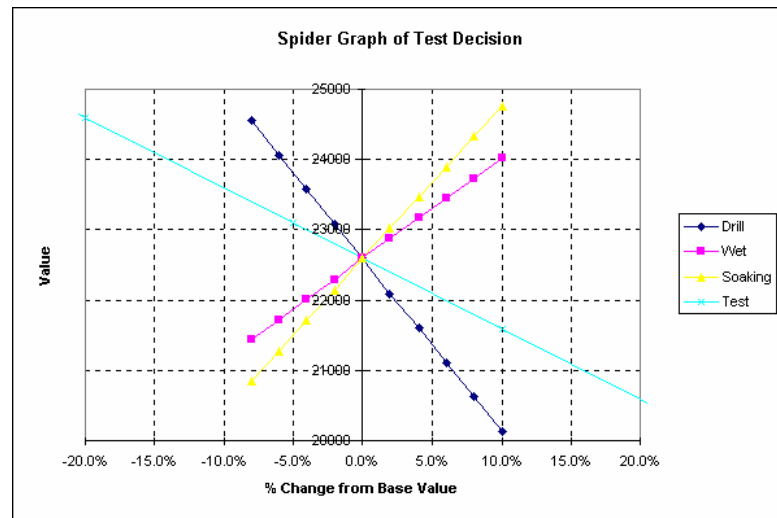



## Results of a Two-Way Sensitivity Analysis

When PrecisionTree runs a two-way sensitivity analysis, the following graphs and reports are generated:

### Two-Way Sensitivity Graph

When selected, this option generates a two-way sensitivity graph for each pair of *Cells to Vary*. This is a three dimensional chart that displays the value for the *Cell to Analyze* at each possible combination in value of the *Cells to Vary*. The *Cells to Vary* are shown on the X and Y axis and the values for the *Cell to Analyze* are shown on the Z axis.

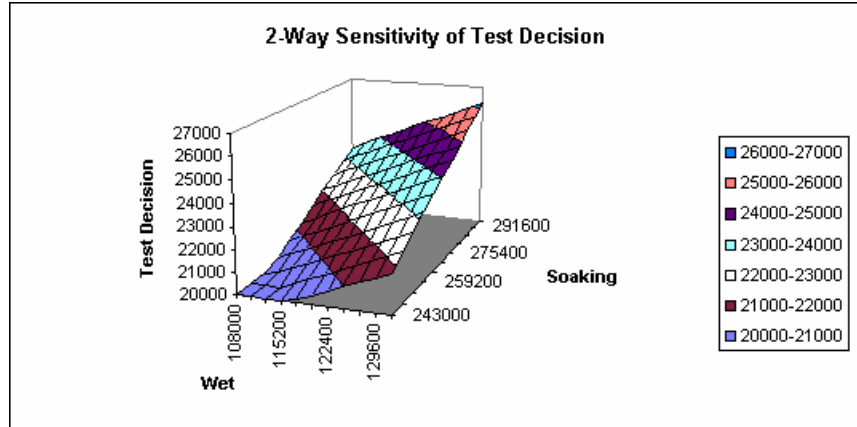

### Strategy Region Graph

Strategy region graphs show regions where different decisions are optimal given changes in two selected variables. The value of the first variable is plotted on the X-axis and the value of the second variable is plotted on the Y-axis. The different symbols in the graph denote the optimal decision at various combinations of values for two variables - in this case, the Wet field value and the Soaking field value. This graph is only generated when the *Cell to Analyze* is the value of a decision node.

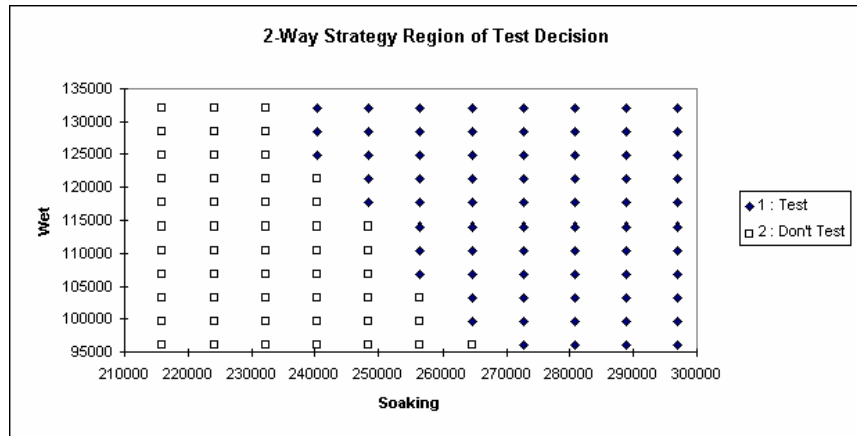

# Graph Options Command

## Analysis Submenu

---

Sets options for a graph of decision analysis results.

---

The *Graph Options* command or the *Options* button on a displayed graph sets the X or Y axis scaling or number of intervals for a risk profile or cumulative risk profile graph. For other graph types, use the Excel scaling options for setting axis scaling.

An *Options* button is displayed on each created risk profile or cumulative risk profile graph. Clicking this button displays the *Graph Options* dialog box for the current graph. If the *Graph Options* command is selected from the PrecisionTree menu, a graph must be selected in a worksheet for the *Graph Options* dialog to be displayed.

### Graph Options Dialog

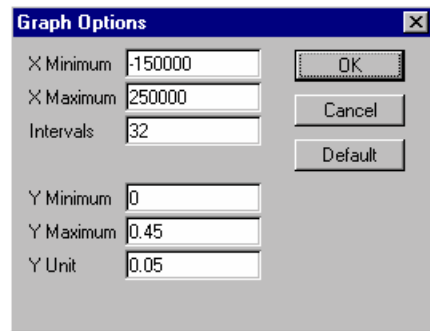

The following options are available in the *Graph Options* dialog box:

### **X-Minimum and X-Maximum**

The *X-Minimum* and *X-Maximum* options set the X-axis scaling used for the selected graph.

### **Y-Minimum and Y-Maximum**

The *Y-Minimum* and *Y-Maximum* options set the Y-axis scaling used for the selected graph.

### **Y Unit**

The *Y Unit* option specifies the size of the unit for tick marks on the Y-axis.

### **Default**

The *Default* option resets the current graph to the scaling, interval and unit defaults calculated by PrecisionTree.

### **Intervals**

The *Intervals* option sets the number of bins to be used for creating the displayed risk profile graph. The fewer the *Intervals*, the greater the width of the bars displayed in the risk profile graph. When calculating the probability value associated with each bar, PrecisionTree first divides the X-axis scale into the number of *Intervals* specified. The portion of the total results which falls into each *Interval* is then calculated. The sum of the heights of bars for all *Intervals* equals one.

## Zoom Selection Command



### **Zoom Selection Icon**

The *Zoom Selection* command or the *Zoom Selection* icon on the PrecisionTree toolbar zooms in or out on a selected part of a decision tree. Use this command to either see more detail on a selected portion of a tree or reduce a tree to fit in a displayed spreadsheet.

### **Zooming in on a Portion of a Tree**

To zoom in on a portion of a tree:

- 1) *Highlight the region of the tree you want to zoom in on by selecting the region in your spreadsheet.*
- 2) *Click the Zoom icon. The selected region will be enlarged to fill the current window.*

### **Reducing a Tree to Fit the Current Window**

To reduce a tree to fit in the current window:

- 1) *Select a single cell in the window where the tree you wish to reduce is located.*
- 2) *Click the Zoom icon. The selected tree will be reduced in size.*

## Update Links Command



### **Update Links Icon**

Selecting the *Update Links* command or clicking the *Update Links* icon forces all end node payoffs in all open linked trees to be updated. This command is used when the *Automatically Update Links* option in the *Tree Settings* dialog is turned off because a large linked tree is being edited and the continued recalculations slow performance.

# Contents Command

## *Help Submenu*

---

**Displays the on-line help for PrecisionTree.**

---

The Contents command opens PrecisionTree's on-line help file. If you need more information on using the help file, select How to Use Help from the program's Help menu.

# Authorization Command

## *Help Submenu*

---

**Displays authorization information for PrecisionTree and allows the authorization of trial versions**

---

The Help menu Authorization command displays the Authorization dialog box, listing the version and authorization information for your copy of PrecisionTree. Using this dialog box you can also convert a trial version of PrecisionTree into an authorized copy.

# About Command

## *Help Submenu*

---

**Displays version and copyright information about PrecisionTree**

---

The Help menu About command displays the About dialog box, listing the version and copyright information for your copy of PrecisionTree.

---

# Chapter 6: Distribution and Simulation Function Reference

<b>Introduction</b> .....	<b>141</b>
Distribution Functions.....	141
Simulation Output Functions.....	146
Simulation Statistics Functions .....	147
Graphing Function.....	147
Supplemental Functions .....	147
<b>Table of Available Functions</b> .....	<b>149</b>



# Introduction

Probability distribution functions are used for adding uncertainty — in the form of probability distributions — to the cells and equations in your decision models. Probability distributions can be used in the following ways in a decision tree in PrecisionTree:

- ◆ *Describing distributed chance nodes*
- ◆ *Describing uncertain values in any other cells and formulas for use during an @RISK simulation*

The probability distribution functions provided with PrecisionTree are those provided with @RISK, Palisade's risk analysis and simulation add-in for Excel. These functions can be entered directly in any spreadsheet cell or formula, or in any branch definition formula. @RISK also includes custom functions that can be included in Excel cells and formulas when setting up a simulation model. These include:

- 1) **Defining simulation outputs** (*RiskOutput* function)
- 2) **Returning simulation results to your spreadsheet** (*@RISK statistics* and *graphing* functions)

This reference chapter describes each type of @RISK function and gives details about both the required and optional arguments for each function.

## Distribution Functions

Probability distribution functions are used for adding uncertainty — in the form of probability distributions — to the cells and equations in your Excel worksheet. For example, you could enter `RiskUniform(10,20)` to a cell in your worksheet. This specifies that the values for the cell will be generated by a uniform distribution with a minimum of 10 and a maximum of 20. This range of values replaces the single "fixed" value required by Excel.

Distribution functions are used by @RISK during a simulation for sampling sets of possible values. Each iteration of a simulation uses a new set of values sampled from each distribution function in your worksheet. These values are then used in recalculating your worksheet and generating a new set of possible results.

As with Excel functions, distribution functions contain two elements, a function name and argument values which are enclosed in parentheses. A typical distribution function is:

**RiskNormal(100,10)**

A different distribution function is used for each type of probability distribution. The type of distribution which will be sampled is given by the name of the function. The parameters which specify the distribution are given by the arguments of the function.

The number and type of arguments required for a distribution function vary by function. In some cases, such as with:

**RiskNormal(mean,standard deviation)**

a fixed number of arguments are specified each time you use the function. For others, such as DISCRETE, you specify the number of arguments you desire, based on your situation. For example, a DISCRETE function may specify two possible outcomes, or three, or more as needed.

Like Excel functions, distribution functions may have arguments which are references to cells or expressions. For example:

**RiskTriang(B1,B2\*1.5,B3)**

In this case the cell value would be specified by a triangular distribution with a minimum value taken from cell B1, a most likely value calculated by taking the value for cell B2 and multiplying it by 1.5 and a maximum value taken from cell B3.

Distribution functions also may be used in cell formulas, just as are Excel functions. For example, a cell formula could read:

**B2: 100+RiskUniform(10,20)+(1.5\*RiskNormal(A1,A2))**

All standard Excel editing commands are available to you when entering distribution functions. However, you will need to have PrecisionTree or @RISK loaded for the distribution functions to be sampled by Excel. If it is not attached, Excel will return the expected value of the function when the worksheet is recalculated.

To enter probability distribution functions:

- 1) Examine your worksheet and identify those cells which you think have uncertain values

Look for those cells where the actual values which occur could vary from those shown in the worksheet. At first, identify those important variables whose cell values may have the largest variation in value. As your Risk Analysis gets more refined, you can further expand your use of distribution functions throughout the worksheet.

- 1) Select distribution functions for the cells you have identified. In Excel, use the Insert menu Function command to enter the selected functions into formulas.



You have over thirty types of distributions to choose from when selecting a distribution function. Unless you know specifically how uncertain values are distributed it is a good idea to start with some of the simpler distribution types — uniform, triangular, or normal. As a starting point, if possible, specify the current cell value as the mean or most likely value of the distribution function. The range of the function you are using then reflects the possible variation around the mean or most likely value.

The simple distribution functions can be very powerful as you can describe uncertainty with only a few values or arguments. For example:

- **RiskUniform**(*Minimum, Maximum*) uses only two values to describe the full range of the distribution and assign probabilities for all the values in the range.
- **RiskTriang**(*Minimum, Most Likely, Maximum*) uses three easily identifiable values to describe a complete distribution.

As your models become more complex, you probably will want to choose from more complex distribution types in order to meet your specific modeling needs.

### **Defining Distributions Graphically**

A graph of the distribution is often helpful in selecting and specifying distribution functions. You can use **@RISK Define Distribution** window to display distribution graphs and add distribution functions to cell formulas. To do this, select the cell where you wish to add a distribution function and click the Define Distribution icon on the @RISK toolbar or the @RISK add-in menu Model Define Distribution command. For more information on the Define Distribution window, see the **Model Menu: Define Distribution Command** in the **@RISK Add-In Menu Commands** section in the @RISK manual. (Note: @RISK must be loaded with PrecisionTree to use the **Define Distribution** window.)

It often helps to first use the Define Distribution window to enter your distribution functions to better understand how to assign values to function arguments. Then, once you better understand the syntax of distribution function arguments, you can enter the arguments yourself directly in Excel, bypassing the Define Distribution window.

### ***Fitting Data to Distributions***

The @RISK Model window (Professional and Industrial versions only) allows you to fit probability distributions to your data. The distributions which result from a fit are then available to be assigned as input distributions and added to your spreadsheet model. By setting the **Source**: in the Define Distribution window to **Fit Results**, you can use the fit results from any Fit Tab for assigning distributions to model inputs. For more information on distribution fitting see the **Fitting Menu Commands** in the **@RISK Model Window Commands** section in the @RISK manual.

### ***Distribution Property Functions***

Optional arguments to distribution functions can be entered using **Distribution Property** functions. These optional arguments are used to name an input distribution for reporting and graphing, truncate the sampling of a distribution, correlate the sampling of a distribution with other distributions and keep a distribution from being sampled during a simulation. These arguments are not required, but can be added as needed.

Optional arguments specified using @RISK distribution property functions are embedded inside of a distribution function. Distribution Property functions are entered just as are standard Excel functions and can include cell references and mathematical expressions as arguments.

For example, the following function truncates the entered normal distribution to a range with a minimum value of 0 and a maximum value of 20:

**=RiskNormal(10,5,RiskTruncate(0,20))**

No samples will be drawn outside this minimum-maximum range.

### **Entering Arguments in @RISK Functions**

The guidelines for entering Excel functions presented in the relevant User's Guide are also applicable to entering @RISK functions. However, some additional guidelines specific to @RISK functions are:

- Where integer arguments are required by a distribution function, any non-integer argument values will be truncated to integers.
- Integer arguments must be greater than or equal to -32,767 and less than or equal to 32,767. Values outside this range will cause the function to return #VALUE in Excel.
- Distribution functions with varying numbers of arguments (such as HISTOGRM, DISCRETE, and CUMUL) require that arguments of the same type be entered as arrays. Arrays in Excel are denoted by either enclosing the values of the array in {} brackets or using a reference to a contiguous range of cells — such as A1:C1. If a function takes a varying number of value/probability pairs, the values will be one array and the probabilities another. The first value in the value array is matched with the first probability in the probability array and so on.

### **Optional Arguments**

Some @RISK functions have **optional** arguments, or arguments that may be used but are not required. The **RiskOutput** function, for example, has only optional arguments. You can use it with 0, 1 or 3 arguments, depending on what information you wish to define about the output cell where the function is used. You can:

- 1) Just identify the cell as an output, letting @RISK automatically generate a name for you (i.e., =RiskOutput()).
- 2) Give the output a name you select (i.e., =RiskOutput("Profit 1999")).
- 3) Give the output a name you select and identify it as part of an output range (i.e., =RiskOutput("Profit 1999", "Profit By Year",1)).

Any of these forms of the **RiskOutput** function are allowed because all of its arguments are optional.

When an @RISK function has optional arguments you can add the optional arguments you choose and ignore the rest. You must, however, include all required arguments. For example, for the **RiskNormal** function, two arguments, *mean* and *standard deviation*, are required. All of the arguments which can be added to the RiskNormal function via *distribution property functions* are optional and can be entered in any order you like.

**Important Note  
on Excel Arrays**

In Excel, you may not list cell references or names in arrays as you would list constants. For example, you could not use {A1,B1,C1} to represent the array containing the values in cells A1, B1, and C1. Instead, you must use the cell range reference A1:C1 or enter the values of those cells directly in the arrays as constants — for example, {10,20,30}.

- Distribution functions with fixed numbers of arguments will return an error value if an insufficient number of arguments is entered and will ignore extra arguments if too many are entered.
- Distribution functions will return an error value if arguments are of the wrong type (number, array or text).

**More  
Information**

This section briefly describes each probability distribution function available and the arguments required for each. In addition, the *Technical Appendices* describe the technical characteristics of each probability distribution function. The appendices include formulas for density, distribution, mean, mode, distribution parameters and graphs of the probability distributions generated using typical argument values.

### **Simulation Output Functions**

Output cells are defined using *RISKOutput* functions. These functions allow the easy copying, pasting and moving of output cells. RISKOutput functions are automatically added when the standard @RISK Add Output icon is pressed. RISKOutput functions optionally allow you to name your simulation outputs and add individual output cells to output ranges. A typical RISKOutput function might be:

*=RiskOutput("Profit")+NPV(.1,H1...H10)*

where the cell, prior to its selection as a simulation output, simply contained the formula

*= NPV(.1,H1...H10)*

The added RiskOutput function selects the cell as a simulation output and gives the output the name "Profit".

## Simulation Statistics Functions

@RISK statistics functions return a desired statistic on simulation results. For example, the function *RiskMean(A10)* returns the mean of the simulated distribution for the cell A10. These functions are updated real-time as a simulation is running.

@RISK statistics functions include all standard statistics plus percentiles, targets (for example, *=RiskPercentile(A10,.99)* returns the 99<sup>th</sup> percentile of the simulated distribution). @RISK statistics functions can be used the way you would use any standard Excel function.

Statistics functions may also reference a simulation output or input by name. This allows them to be included in templates which are used to generate pre-formatted reports in Excel on simulation results. For example, the function *=RiskMean("Profit")* would return the mean of the simulated distribution for the output cell named Profit defined in a model.

***Note: A cell reference entered in a statistics function does not have to be a simulation output identified with a RiskOutput function.***

## Graphing Function

A special @RISK function *RiskResultsGraph* will automatically place a graph of simulation results wherever it is used in a spreadsheet. For example, *=RiskResultsGraph(A10)* would place a graph of the simulated distribution for A10 directly in your spreadsheet at the function's location at the end of a simulation. Additional optional arguments to *RiskResultsGraph* allow you to select the type of graph you want to create, its format, scaling and other options.

## Supplemental Functions

Two additional functions — **CurrentIter** and **CurrentSim** — are provided for use in the development of macro-based applications using @RISK. These functions return the current iteration and current simulation, respectively, of an executing simulation.



# Table of Available Functions

This table lists the custom functions that are added to Excel by @RISK. When used, all functions are preceded by the entry **RISK**.

Distribution Function	Returns
<b>BETA</b> ( <i>alpha1,alpha2</i> )	beta distribution with shape parameters <i>alpha1</i> and <i>alpha2</i>
<b>BETAGENERAL</b> ( <i>alpha1,alpha2,minimum,maximum</i> )	beta distribution with defined <i>minimum,maximum</i> and shape parameters <i>alpha1</i> and <i>alpha2</i>
<b>BETASUBJ</b> ( <i>minimum,most likely,mean,maximum</i> )	beta distribution with defined <i>minimum,maximum,most likely</i> and <i>mean</i>
<b>BINOMIAL</b> ( <i>n,p</i> )	binomial distribution with <i>n</i> draws and <i>p</i> probability of success on each draw
<b>CHISQ</b> ( <i>v</i> )	Chi-Square distribution with <i>v</i> degrees of freedom
<b>CUMUL</b> ( <i>minimum,maximum,{X1,X2,...,Xn},{p1,p2,...,pn}</i> )	cumulative distribution with <i>n</i> points between <i>minimum</i> and <i>maximum</i> with cumulative probability <i>p</i> at each point
<b>DISCRETE</b> ( <i>{X1,X2,...,Xn},{p1,p2,...,pn}</i> )	discrete distribution with <i>n</i> possible outcomes with the value <i>X</i> and probability weight <i>p</i> for each outcome
<b>DUNIFORM</b> ( <i>{X1,X2,...,Xn}</i> )	discrete uniform distribution with <i>n</i> outcomes valued at <i>X1</i> through <i>Xn</i>
<b>ERF</b> ( <i>h</i> )	error function distribution with variance parameter <i>h</i>
<b>ERLANG</b> ( <i>m,beta</i> )	m-erlang distribution with integral shape parameter <i>m</i> and scale parameter <i>beta</i>
<b>EXPON</b> ( <i>beta</i> )	exponential distribution with decay constant <i>beta</i>

Distribution Function	Returns
<b>EXTVALUE</b> ( <i>a,b</i> )	extreme value (or Gumbel) distribution with location parameter <i>a</i> and scale parameter <i>b</i>
<b>GAMMA</b> ( <i>alpha,beta</i> )	gamma distribution with shape parameter <i>alpha</i> and scale parameter <i>beta</i>
<b>GEOMETRIC</b> ( <i>p</i> )	geometric distribution with probability <i>p</i>
<b>GENERAL</b> ( <i>minimum,maximum, {X1,X2,...,Xn},{p1,p2,...,pn}</i> )	general density function for a probability distribution ranging between minimum and maximum with <i>n</i> ( <i>x,p</i> ) pairs with value <i>X</i> and probability weight <i>p</i> for each point
<b>HISTOGRM</b> ( <i>minimum,maximum,{p1,p2,...,pn}</i> )	histogram distribution with <i>n</i> classes between <i>minimum</i> and <i>maximum</i> with probability weight <i>p</i> for each class
<b>HYPERGEO</b> ( <i>n,D,M</i> )	hypergeometric distribution with sample size <i>n</i> , <i>D</i> number of items and <i>M</i> population size
<b>INTUNIFORM</b> ( <i>minimum,maximum</i> )	uniform distribution which returns integer values only between <i>minimum</i> and <i>maximum</i>
<b>INVGAUSS</b> ( <i>mu,lambda</i> )	inverse gaussian (or Wald) distribution with mean <i>mu</i> and shape parameter <i>lambda</i>
<b>LOGISTIC</b> ( <i>alpha,beta</i> )	logistic distribution with location parameter <i>alpha</i> and scale parameter <i>beta</i>
<b>LOGLOGISTIC</b> ( <i>gamma,beta,alpha</i> )	log-logistic distribution with location parameter <i>gamma</i> , scale parameter <i>beta</i> and shape parameter <i>alpha</i>
<b>LOGNORM</b> ( <i>mean,standard deviation</i> )	lognormal distribution with specified <i>mean</i> and <i>standard deviation</i>
<b>LOGNORM2</b> ( <i>mean,standard deviation</i> )	lognormal distribution generated from the "log" of a normal distribution with specified <i>mean</i> and <i>standard deviation</i>
<b>NEGBIN</b> ( <i>s,p</i> )	negative binomial distribution with <i>s</i> successes and <i>p</i> probability of success on each trial
<b>NORMAL</b> ( <i>mean,standard deviation</i> )	normal distribution with given <i>mean</i> and <i>standard deviation</i>



Distribution Function	Returns
<b>PARETO</b> ( <i>theta,a</i> )	pareto distribution
<b>PARETO2</b> ( <i>b,q</i> )	pareto distribution
<b>PEARSON5</b> ( <i>alpha,beta</i> )	pearson type V (or inverse gamma) distribution with shape parameter <i>alpha</i> and scale parameter <i>beta</i>
<b>PEARSON6</b> ( <i>beta,alpha1, alpha2</i> )	pearson type VI distribution with scale parameter <i>beta</i> and shape parameters <i>alpha1</i> and <i>alpha2</i>
<b>PERT</b> ( <i>minimum,most likely, maximum</i> )	pert distribution with specified <i>minimum</i> , <i>most likely</i> and <i>maximum</i> values
<b>POISSON</b> ( <i>lambda</i> )	poisson distribution
<b>RAYLEIGH</b> ( <i>b</i> )	rayleigh distribution with scale parameter <i>b</i>
<b>SIMTABLE</b> ( <i>{X1,X2,...Xn}</i> )	lists values to be used in each of a series of simulations
<b>STUDENT</b> ( <i>nu</i> )	student's t distribution with <i>nu</i> degrees of freedom
<b>TRIANG</b> ( <i>minimum,most likely, maximum</i> )	triangular distribution with defined <i>minimum</i> , <i>most likely</i> and <i>maximum</i> values
<b>TRIGEN</b> ( <i>bottom,most likely,top, bottom perc.,top perc.</i> )	triangular distribution with three points representing value at <i>bottom percentile</i> , <i>most likely</i> value and value at <i>top percentile</i> .
<b>UNIFORM</b> ( <i>minimum,maximum</i> )	uniform distribution between <i>minimum</i> and <i>maximum</i>
<b>WEIBULL</b> ( <i>alpha,beta</i> )	weibull distribution with shape parameter <i>alpha</i> and scale parameter <i>beta</i>

Distribution Property Function	Specifies
<b>COLLECT()</b>	Causes samples to be collected during a simulation for the distribution in which the Collect function is included (when simulation settings specify Collect Samples for Distributions Marked with Collect only)
<b>CORRMAT</b> ( <i>matrix cell range, position, instance</i> )	Identifies a <i>matrix</i> of rank correlation coefficients and a <i>position</i> in the matrix for the distribution in which the Corrmat function is included. <i>Instance</i> specifies the instance of the matrix at matrix cell range that will be used for correlating this distribution.
<b>DEPC</b> ( <i>"ID", coefficient</i> )	Identifies dependent variable in correlated sampling pair with rank correlation <i>coefficient</i> and <i>"ID"</i> identifier string
<b>FIT</b> ( <i>ProjID, FitID, "selected fit result"</i> )	Links a data set identified by <i>ProjID</i> and <i>FitID</i> and its fit results to the input distribution so the input can be updated when data changes
<b>INDEPC</b> ( <i>"ID"</i> )	Identifies independent distribution in rank correlated sampling pair — <i>"ID"</i> is identifier string
<b>LOCK()</b>	Blocks sampling of the distribution in which the Lock function is included
<b>NAME</b> ( <i>"input name"</i> )	<i>Input name</i> for the distribution in which the Name function is included
<b>SHIFT</b> ( <i>shift</i> )	Shifts the domain of the distribution in which the Shift function is included by <i>shift</i> value
<b>TRUNCATE</b> ( <i>minimum, maximum</i> )	<i>Minimum-maximum</i> range allowable for samples drawn for the distribution in which the Truncate function is included
Output Function	Specifies
<b>OUTPUT</b> ( <i>"name", "output range name", position in range</i> )	Simulation output cell with <i>name</i> , <i>output range name</i> to which the output belongs, and the <i>position in range</i> ( <i>Note: all arguments to this function are optional</i> )

<b>Statistics Function</b>	<b>Returns</b>
<b>DATA</b> ( <i>cellref or output/input name, iteration#, Sim#</i> )	Data value of the simulated distribution for the entered <i>cellref</i> or <i>output/input name</i> in <i>iteration#</i> and <i>Sim#</i>
<b>KURTOSIS</b> ( <i>cellref or output/input name, Sim#</i> )	Kurtosis of the simulated distribution for the entered <i>cellref</i> or <i>output/input name</i> in <i>Sim#</i>
<b>MAX</b> ( <i>cellref or output/input name, Sim#</i> )	Maximum value of the simulated distribution for <i>cellref</i> or <i>output/input name</i> in <i>Sim#</i>
<b>MEAN</b> ( <i>cellref or output/input name, Sim#</i> )	Mean of the simulated distribution for <i>cellref</i> or <i>output/input name</i> in <i>Sim#</i>
<b>MIN</b> ( <i>cellref or output/input name, Sim#</i> )	Minimum value of the simulated distribution for <i>cellref</i> or <i>output/input name</i> in <i>Sim#</i>
<b>MODE</b> ( <i>cellref or output/input name, Sim#</i> )	Mode of the simulated distribution for <i>cellref</i> or <i>output/input name</i> in <i>Sim#</i>
<b>PERCENTILE</b> ( <i>cellref or output/input name, perc%, Sim#</i> )	Percentile <i>perc%</i> of the simulated distribution for <i>cellref</i> or <i>output/input name</i> in <i>Sim#</i>
<b>RANGE</b> ( <i>cellref or output/input name, Sim#</i> )	Range of the simulated distribution for <i>cellref</i> or <i>output/input name</i> in <i>Sim#</i>
<b>SKEWNESS</b> ( <i>cellref or output/input name, Sim#</i> )	Skewness of the simulated distribution for <i>cellref</i> or <i>output/input name</i> in <i>Sim#</i>
<b>STDDEV</b> ( <i>cellref or output/input name, Sim#</i> )	Standard deviation of the simulated distribution for <i>cellref</i> or <i>output/input name</i> in <i>Sim#</i>
<b>TARGET</b> ( <i>cellref or output/input name, target value, Sim#</i> )	Cumulative probability of <i>target value</i> in the simulated distribution for <i>cellref</i> or <i>output/input name</i> in <i>Sim#</i>
<b>VARIANCE</b> ( <i>cellref or output/input name, Sim#</i> )	Variance of the simulated distribution for <i>cellref</i> or <i>output/input name</i> in <i>Sim#</i>

Supplemental Function	Returns
<b>CURRENTITER()</b>	returns the current iteration of the simulation
<b>CURRENTSIM()</b>	returns the current simulation number
Graphing Function	Returns
<b>RESULTSGRAPH</b> ( <i>cellRef</i> or <i>output/input name</i> , <i>graphType</i> , <i>xlFormat</i> , <i>leftdelimiter</i> , <i>rightdelimiter</i> , <i>xMin</i> , <i>xMax</i> , <i>xScale</i> , <i>Sim#</i> )	Graph of the simulated distribution for the entered <i>cellref</i> or <i>output/input name</i> in <i>Sim#</i> , displayed using <i>graphType</i> in metafile or <i>xlFormat</i> , with <i>leftdelimiter</i> , <i>rightdelimiter</i> locations for delimiters and <i>xMin</i> , <i>xMax</i> , <i>xScale</i> settings for X-axis.

---

# Appendix A: Bayes' Theorem

Introduction .....	157
Derivation of Bayes' Theorem .....	159
Using Bayes' Theorem .....	161



# Introduction

We mentioned in the *Overview to Decision Analysis* that conditional arcs are reversible. That must mean that we can exchange the order of two chance events in a decision tree. Let's consider a decision including two chance events; Rain in Boston and Rain in New York. You have decided that the two events are dependent - if it rains in Boston, it is more likely that it will rain in New York. On the other hand, can't you say that if it rains in New York, it is more likely that it will rain in Boston?

## Rainy Day Model

Here's how the events appear on an influence diagram:



And a decision tree:

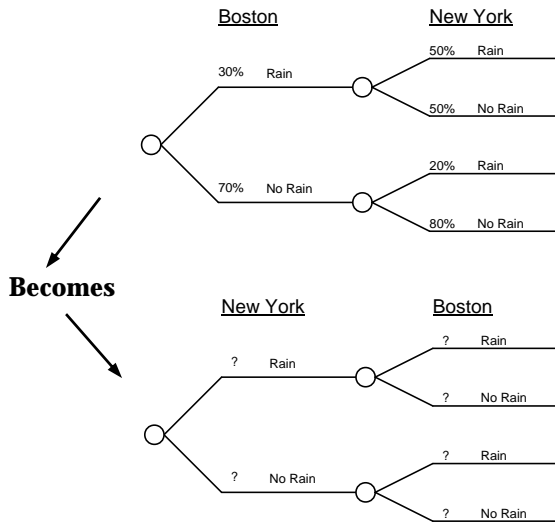

This process is sometimes called "flipping" a probability tree. But now we need to redefine the probabilities associated with each event. That's where Bayes' theorem comes in handy. Bayes' theorem is an algebraic formula that describes the relationship among the probabilities of dependent events.

## Definition of Terms

If your memory of probability theory is rusty, here's a quick review of the notation used in this appendix.

$P(A)$  *the probability that an event A will occur*

$P(AB)$  *the probability that events A and B will both occur (A and B), is equal to  $P(BA)$*

$P(A|B)$  *the probability that event A will occur if B occurs (A given B), does not equal  $P(B|A)$*

$P(\tilde{A})$  *the probability that event A will not occur (not A), equals  $1 - P(A)$*



# Derivation of Bayes' Theorem

Bayes' theorem is easy to derive using simple probability theory. First, we'll start with two basic rules:

i. 
$$P(A|B) = \frac{P(AB)}{P(B)}$$

ii. 
$$P(A) = P(AB) + P(A\bar{B})$$

When we flip a tree, we typically know the probability of event X and the probability of event Y given the occurrence of event X ( $P(X)$  and  $P(Y|X)$ ). We usually need to calculate the probability of event X given the occurrence of event Y ( $P(X|Y)$ ) in terms of what we already know. We can construct the following expression from equation **i**:

iii. 
$$P(X|Y) = \frac{P(XY)}{P(Y)}$$

Using equation **ii**, we can say:

iv. 
$$P(Y) = P(XY) + P(\bar{X}Y)$$

We can combine this expression with equation **iii**:

v. 
$$P(X|Y) = \frac{P(XY)}{P(XY) + P(\bar{X}Y)}$$

But, we may not know  $P(XY)$  and  $P(\bar{X}Y)$ , so we can use equation **i** to find new expressions for them:

vi. 
$$P(XY) = P(Y|X)P(X)$$

vii. 
$$P(\bar{X}Y) = P(Y|\bar{X})P(\bar{X})$$

We can substitute these expressions into equation **v** to get Bayes' theorem:

## **Bayes' Theorem**

viii. 
$$P(X|Y) = \frac{P(Y|X)P(X)}{P(Y|X)P(X) + P(Y|\bar{X})P(\bar{X})}$$

Bayes' theorem describes the probability of event X given the occurrence of event Y using values we already know.

Another value that may be useful is the probability of event Y. It may be found by combining equations **i** and **ii**. Let's start by using equation **ii**:

ix. 
$$P(Y) = P(XY) + P(\bar{X}Y)$$

We can find  $P(XY)$  and  $P(\tilde{X}Y)$  using equation i:

x.  $P(XY) = P(Y|X)P(X)$

xi.  $P(\tilde{X}Y) = P(Y|\tilde{X})P(\tilde{X})$

Combining these equations leads to the expression:

xii.  $P(Y) = P(Y|X)P(X) + P(Y|\tilde{X})P(\tilde{X})$

# Using Bayes' Theorem

All of these equations are great, but how do they apply to your decision tree? Let's use Bayes' theorem on the example we described earlier. First, let's add probability notation to our two trees.

**Rainy Day Model with Probability Notation**

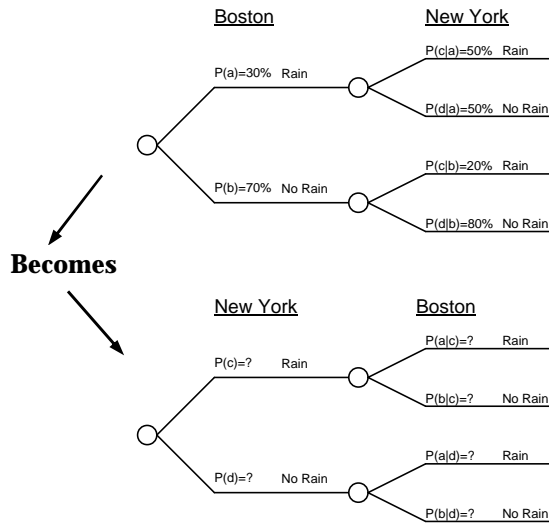

For our new tree, we need to calculate the probability that it will rain in Boston if it rains in New York, or  $P(a|c)$ . Let's substitute our variables into Bayes' theorem:

$$\text{xiii. } P(a|c) = \frac{P(c|a)P(a)}{P(c|a)P(a) + P(c|\bar{a})P(\bar{a})}$$

For this example,  $P(\bar{a}) = P(b)$  since there are only two events corresponding to the chance node:

$$\text{xiv. } P(a|c) = \frac{P(c|a)P(a)}{P(c|a)P(a) + P(c|b)P(b)}$$

Fortunately, we know all the values needed to solve this equation:

$$\text{xv. } P(a|c) = \frac{.5 \times .3}{(.5 \times .3) + (.2 \times .7)} = .52$$

We can use the same method to solve for  $P(b|c)$ ,  $P(a|d)$  and  $P(b|d)$ . But, what about  $P(c)$ ? That's easy! All we need to do is use equation **xii** (remember that  $P(\bar{a}) = P(b)$ ):

$$\text{xvi. } P(c) = P(c|a)P(a) + P(c|\bar{a})P(\bar{a}) = P(c|a)P(a) + P(c|b)P(b)$$

Fortunately, we know all the values needed to solve this equation:

$$\text{xvii. } P(c) = (.5 \times .3) + (.2 \times .7) = .29$$

We can use the same method to solve for  $P(d)$ . Here's what our decision tree looks like once we've solved for all the missing values:

**Solution to  
Rainy Day  
Model**

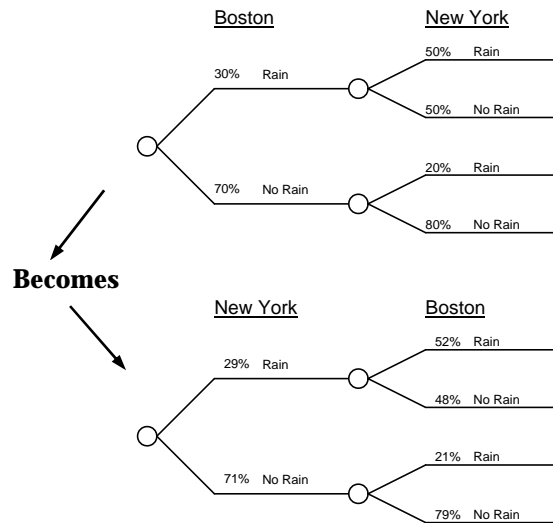

As you can see, the probabilities at each chance node still sum to 1. The two trees describe the same situation using different probability values.

Bayes' theorem may be used in any situation where you need to calculate conditional probabilities after collecting data. Decision makers who assign probability distributions to the parameters of a model and use Bayes' theorem to make inferences about the model are making what's known as Bayesian revisions to their model. PrecisionTree uses Bayesian methods to solve your decision models.

---

# Appendix B: Utility Functions

What is Risk.....	165
Risk Can be Objective or Subjective .....	165
Deciding that Something is Risky Requires Personal Judgment .	165
Risks are Things We Can Often Choose to Accept or Avoid .....	166
Measuring Risk With Utility Functions .....	167
Expected Utility .....	167
Certainty Equivalent .....	168
Risk Premium .....	168
PrecisionTree and Utility Functions .....	169
Exponential Utility Function .....	169
Custom Utility Functions .....	171
Logarithmic Utility Function .....	171
Square-Root Utility Function .....	171
Defining Custom Utility Functions.....	172



# What is Risk?

Risk derives from our inability to see into the future, and indicates a degree of uncertainty that is significant enough to make us notice it. This somewhat vague definition takes more shape by mentioning several important characteristics of risk.

## Risk Can be Objective or Subjective

Flipping a coin is an objective risk because the odds are well known. Even though the outcome is uncertain, an objective risk can be described precisely based on theory, experiment, or common sense. Everyone agrees on the description of an objective risk. Describing the odds for rain next Thursday represents a subjective risk. Given the same information (theory, computers, etc.), weatherman A may think the odds of rain are 30% while weatherman B may think the odds are 65%. Neither is wrong. Describing a subjective risk is open-ended in the sense that you can always refine your assessment with new information, further study, or by giving weight to the opinion of others. Most of the risks in your decision models are subjective.

## Deciding that Something is Risky Requires Personal Judgment

Consider the following decision between two investments:

*Investment Model*

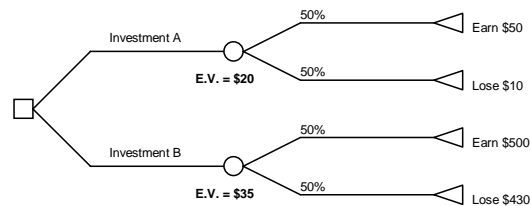

This example describes a decision between two investments of varying risk. Investment B has the highest expected value, and would be selected if expected value was the only criteria for the decision. But, Investment B seems to be much riskier than Investment A. Most people would choose Investment A over Investment B. But, how can we place a quantitative measurement on the riskiness of a situation?

## **Risks are Things We Can Often Choose to Accept or Avoid**

Individuals differ in the amount of risk they willingly accept. For example, two individuals of equal net worth may react quite differently to the investment decision above — one may choose Investment A while the other chooses Investment B. One decision maker may be risk averse; he prefers a small spread in possible results, with most of the probability associated with desirable results. A risk taker, on the other hand, accepts a greater amount of spread, or possible variation in the outcome distribution. Of course, a person may be risk neutral; he or she does not consider risk when making decisions, only expected value.



# Measuring Risk with Utility Functions

You probably have an idea of how much risk is acceptable to you, but how do you express your risk preference in a decision model? Ideally, you would like to look at a decision and weigh both the expected value and risk of a decision. And, you would like to consider your preference for risk as well. That's where utility functions come in handy.

A utility function is an expression that explains risk by converting the payoff of a decision to utility units. The utility of one decision is then compared to that of another decision to select the optimum decision.

## Typical Utility Functions for Different Decision Makers

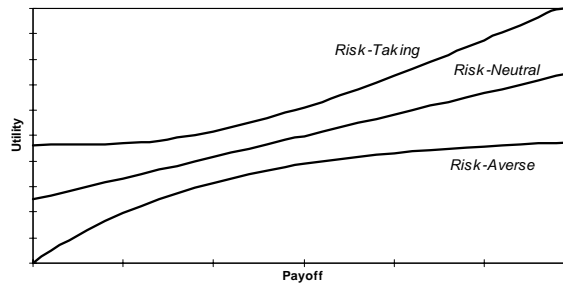

The above example contains typical utility functions for risk averse, risk tolerant and risk neutral decision makers. The typical risk-neutral utility curve is linear (indicating no special weight given to risky situations), while the risk-averse curve is convex.

## Expected Utility

Let's go back to the investment example we discussed earlier. For simplicity, the following utility function is used:

### Utility Function

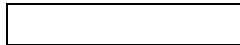

In addition to calculating the expected values of the two investment decisions, we can also calculate the expected utilities, which are the weighted averages of the utility units for each outcome.

### Expected Utility for Investment Model

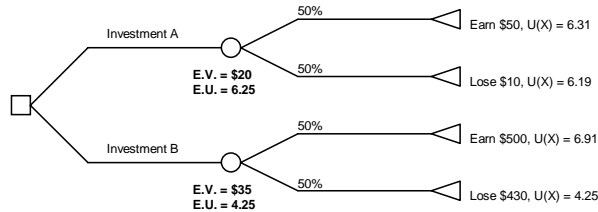

For this example, the expected utility of Investment A is greater than that for Investment B. Even though the expected value of Investment B is greater, Investment A is a better choice. Expected utility seems like a

meaningless number. You can't say to your boss "Let's choose Investment A since it has a utility value of 6.25." You need to express utility in units that mean something to others.

## Certainty Equivalent

The certainty equivalent is the value you place on an uncertain situation. It is the amount of money (in cash) that you would accept to avoid a risky decision. The certainty equivalent of a chance node is calculated using the inverse of the utility function and the expected utility of the node. Instead of making our decision based on the expected utility, we can select the option with the highest certainty equivalent. This always produces the same decision, but uses units we understand.

For our example, we would calculate the certainty equivalent with the following formula:



This formula is the inverse of our utility function. Placing the results into our tree produces:

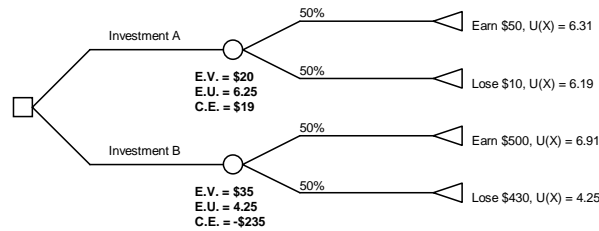

In this model, Investment A has the highest certainty equivalent. This is not surprising since it also has the highest expected utility.

## Risk Premium

How much are you willing to give up to avoid risk? The risk premium is the difference between the expected value and the certainty equivalent of an event. The higher the risk premium for an event, the more risk averse the decision maker is. If the risk premium is a negative number, the decision maker is a risk taker. For a risk neutral situation, the risk premium is zero.

In our example, the risk premium associated with Investment B is \$270. We are willing to give up that much money to avoid the risk associated with this investment. But, we would only give up \$1 to avoid the relatively small risk associated with Investment A.

# PrecisionTree and Utility Functions

PrecisionTree allows you to define a different utility function for every chance node in your model. When you create a new node, PrecisionTree automatically assigns it the default utility function (defined by you). You can change the utility function of a node at any time during the modeling process.

To define a risk neutral decision, simply enter a risk coefficient of zero or set the decision model to expected value. PrecisionTree will base its decisions strictly on expected value.

## Exponential Utility Function

The most common utility function is the exponential utility function. This function is built-in to PrecisionTree and is defined as:

$$U(x) = -\frac{1}{R} e^{-x/R}$$

R is the decision maker's risk tolerance (also called the risk coefficient). A small value of R indicates risk aversion. As R increases, the decision maker becomes more risk tolerant.

### Typical Exponential Utility Curves

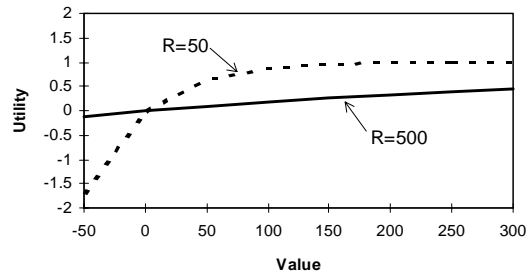

The above example plots two exponential utility curves, one with a risk coefficient of 50 and another with a risk coefficient of 500. The curve with the larger risk coefficient is flatter, thus more risk tolerant than the other curve.

### How to Select a Risk Coefficient

There are many ways to determine the value of R that is right for you. Some industries have a higher tolerance for risky ventures than others. Some companies even have a pre-defined formula for identifying risk tolerance. It is up to you, the decision maker, to determine how much risk you can tolerate for a given decision.

***Drawbacks***

One drawback of the exponential utility function is that it assumes constant risk aversion. In other words, you would view a risky situation the same way no matter how much money you had. This may be a good approximation for some situations, such as when sensitivity analysis determines that varying risk tolerance does not significantly affect the model. But, what do we do when our attitudes toward risk change?

# Custom Utility Functions

PrecisionTree offers a default exponential utility function. But, using Excel's Visual Basic for Applications, you can easily construct your own custom utility function. This section discusses some widely-used utility functions and explains how to use them in your own models.

## Logarithmic Utility Function

Some utility functions take into account the fact that risk becomes more attractive when you have more money (decreasing risk aversion). The logarithmic utility function is commonly used in this case:

$$U(x) = \ln(x + R)$$

The constant  $R$  is added to the expression to insure that PrecisionTree never has to take the log of a negative number (which returns an error). If it is possible that your values of  $x$  could be negative, chose a value of  $R$  large enough so that  $x + R$  can never be less than zero.

### Logarithmic Utility Curves

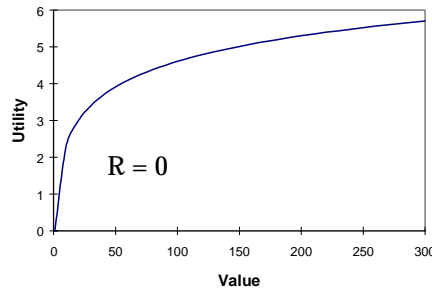

The example above contains a logarithmic utility curve with a risk coefficient of 0. If you change the  $R$  value, the curve merely "shifts" a distance equal to  $R$  along the  $x$ -axis.

## Square-Root Utility Function

The square-root utility function also demonstrates decreasing risk aversion. Its formula is:

$$U(x) = \sqrt{x + R}$$

As with the logarithmic function, the constant  $R$  is added to the expression to insure that PrecisionTree never has to take the square root of a negative number (which return an error). If it is possible that your values of  $x$  could be negative, choose a value of  $R$  large enough so that  $x + R$  can never be less than zero.

## Square-Root Utility Curves

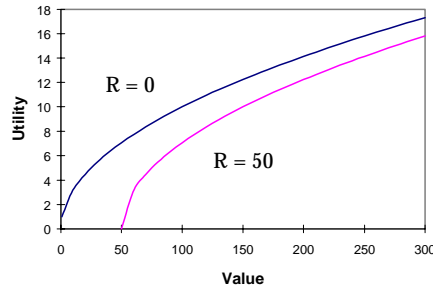

The example above displays two square-root utility curves, one with a risk coefficient of 0 and another with a risk coefficient of 50. They are both the same shape; the R value merely "shifts" the curve along the X-axis.

### Defining Custom Utility Functions

To create your own utility function, write a user-defined function in Excel (see the Excel User's Guide for instructions). Then, write another function for the inverse utility, which converts expected utility to a certainty equivalent. For example, you might use the following functions for a square-root utility function:

**Utility\_SquareRoot(X,R)**

**Inverse\_SquareRoot(EU,R)**

Where X is the expected value of a node, R is the risk coefficient and EU is the expected utility of a chance node.

There are three steps involved in incorporating utility function into your model:

- 1 Use the utility function to calculate utility for each chance outcome.
- 2 Calculate the expected utility of the chance node.
- 3 Convert the expected utility to a certainty equivalent using the inverse utility function.

**Note: for more information on defining utility functions, see the example model *UTILITY.XLS*.**

To demonstrate these techniques, let's look at a portion of the oil drilling example:

**Drilling Decision for Open Test Results**

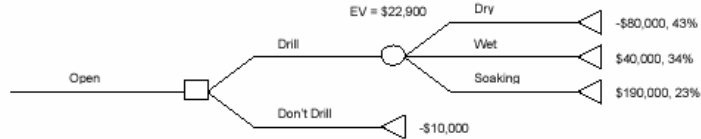

Based on expected value, the optimum decision is to drill. But, will that decision remain the same when the risk of drilling is considered?

With **Utility\_SquareRoot** and **Inverse\_SquareRoot** functions created in VBA and present in an open VBA module, simply type in Utility\_SquareRoot and enter a Risk coefficient. PrecisionTree then recalculates the tree, returning a certainty equivalent at each node.

**Drilling Decision With Certainty Equivalents**

The final decision tree looks like this:

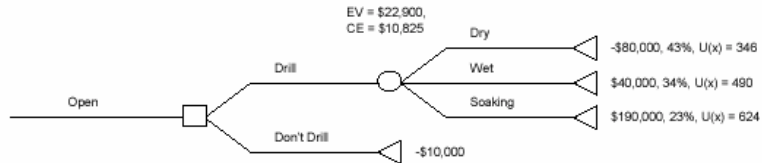

The optimum decision is still to Drill, but the certainty equivalent is significantly smaller than the expected value. So, while our decision has not changed, we are now aware that the risk involved in our decision makes the option less attractive than it once seemed.





---

# Appendix C: Recommended Readings

## Books and Articles on Decision Analysis

The PrecisionTree manual has given you a start on understanding the concepts of decision analysis and simulation. If you're interested in finding out more about the decision analysis techniques and the theory behind them, here are some books and articles which examine various areas in the decision analysis field.

### Introduction to Decision Analysis

- ◆ Baird, Bruce F. *Managerial Decisions Under Uncertainty: An Introduction to the Analysis of Decision Making*. New York: John Wiley and Sons, 1989. (\*)
- ◆ Clemen, R.T. *Making Hard Decisions: An Introduction to Decision Analysis*. Boston: PWS-Kent Publishing Company, 1991. (\*)
- ◆ Raiffa, Howard. *Decision Analysis: Introductory Lectures on Choices Under Uncertainty*. Reading, MA: Addison-Wesley, 1968.

### Technical References to Decision Trees and Influence Diagrams

- ◆ Cockett, J. R. B., and J. A. Herrera. 1990. "Decision Tree Analysis." *Journal of the Association for Computing Machinery*. 37: 815-842.
- ◆ Oliver, Robert M., and James Q. Smith, eds. *Influence Diagrams, Belief Nets and Decision Analysis*. New York: John Wiley and Sons, 1990.
- ◆ Shachter, R. D. 1986. "Evaluating Influence Diagrams." *Operations Research*. 34: 871-882.

### Technical References to Sensitivity Analysis

- ◆ French, S. 1992. "Mathematical Programming Approaches to Sensitivity Calculations in Decision Analysis." *Journal of the Operational Research Society*. 43: 813-819.

## Examples and Case Studies Using Decision Analysis

- ◆ Howard, Ronald A., and James E. Matheson, eds. The Principles and Applications of Decision Analysis. Vols. I and II. Menlo Park: Strategic Decisions Group, 1989.
- ◆ Newendorp, Paul D. Decision Analysis for Petroleum Exploration. Tulsa, OK: PPC Books, 1975.

*The titles marked with an \* can be purchased through Palisade Corporation. To order or to request more information on these and other titles relating to decision analysis, call us at (800) 432-7475 (US only) or (607) 277-8000, fax us at (607) 277-8001, email us at sales@palisade.com, visit our web site at <http://www.palisade.com> or write to us at:*

*Palisade Corporation  
31 Decker Road  
Newfield, NY 14867 USA*

---

# Appendix D: Using PrecisionTree With Other DecisionTools

## The DecisionTools Suite

Palisade's DecisionTools Suite is a complete set of decision analysis solutions for Microsoft Windows. With the introduction of DecisionTools, Palisade brings you a decision-making suite whose components combine to take full advantage of the power of your spreadsheet software.

The DecisionTools Suite focuses on providing advanced tools for any decision, from risk analysis to sensitivity analysis to distribution fitting. Software packaged with the DecisionTools Suite includes:

- **@RISK** — *risk analysis using Monte-Carlo simulation*
- **TopRank** — *sensitivity analysis*
- **BestFit** — *distribution fitting*
- **PrecisionTree** — *decision analysis with decision trees and influence diagrams*
- **RISKview** — *distribution viewing companion*

**Note: When you purchase the DecisionTools Suite, all the features of BestFit and RISKview come fully integrated into your copy of @RISK Professional that comes with the Suite.**

While all the tools listed above can be purchased and used separately, they become more powerful when used together. Analyze historical and fit data for use in an @RISK model. Or use TopRank to determine which variables to define in your @RISK model.

This chapter explains many of the ways the components of the DecisionTools suite interact and how they will make your decision making easier and more effective.

**Note: Palisade also offers a version of @RISK for Microsoft Project. @RISK for Project allows you to run risk analyses on project schedules created in Microsoft Project, the leading software package for project management. Contact Palisade for more information on this exciting implementation of @RISK!**

## **Purchasing Information**

All of the software mentioned here, including the DecisionTools Suite, can be purchased directly from Palisade Corporation. To place an order or receive more information, please contact the technical sales department at Palisade Corporation using one of the following methods:

- *Telephone us at (800) 432-7475 (U.S. only) or (607) 277-8000 any weekday from 8:30 AM to 5:30 PM, EST*
- *Fax us at (607) 277-8001*
- *E-mail us at [sales@palisade.com](mailto:sales@palisade.com)*
- *Visit us on the World Wide Web at <http://www.palisade.com>*
- *Mail us a letter at*

**Technical Sales  
Palisade Corporation  
31 Decker Road  
Newfield, NY 14867**

If you want to contact Palisade Europe:

- *Telephone us at +44 (0) 1752 204310 (UK)*
- *Fax us at +44 (0) 1752 894833 (UK)*
- *E-mail us at [sales@palisade-europe.com](mailto:sales@palisade-europe.com)*
- *Visit us on the World Wide Web at <http://www.palisade—europe.com>*
- *Mail us a letter at*

**Palisade Europe  
The Blue House, Unit 1  
30 Calvin Street  
London E1 6NW UK**

# Palisade's DecisionTools Case Study

The Excelsior Electronics company currently makes desktop computers. They are working on a laptop computer, the Excelsior 5000, and want to know whether or not the company will profit from this venture. They built a spreadsheet model which spans the next two years, each column representing one month. The model takes into account production costs, marketing, shipping, price per unit, units sold, etc. The bottom line for each month is "Profit". Excelsior expects some initial setbacks on this venture, but as long as they are not too great and profits are up towards the end of two years, they will go ahead with the E5000.

## Run TopRank First, Then @RISK

TopRank is used on the model to find the critical variables. The "Profit" cells are selected as outputs, and an automatic What-if analysis is run. The results quickly show there are five variables (out of many more) that have the most impact on profits: price per unit, marketing costs, build time, price of memory, and price of CPU chips. Excelsior decides to concentrate on these variables.

**TopRank  
Identifies Key  
Factors for New  
Computer  
Project**

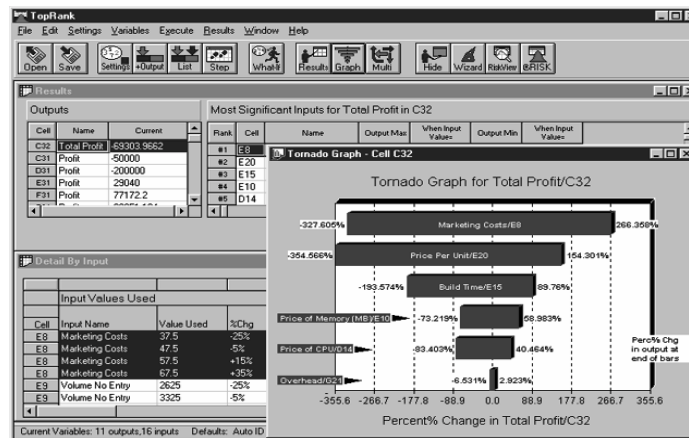

## Next, Assess Probabilities

Distribution functions are needed to replace the five variables in the spreadsheet model. Normal distributions are used for price per unit and build time, based on internal decisions and information from Excelsior's manufacturing division. At a marketing department meeting, @RISK's Artist Window is used by managers to draw distribution curves which represent the range of possible marketing costs. Once a hand-drawn distribution is agreed upon, the **Fit Curve** command provides an @RISK distribution function for use in the model.

## Add Distribution Fitting

Research is done to get weekly price quotes for memory and CPU's over the past two years. This data is fed into @RISK's distribution fitting and distributions are fitted to the data. Confidence level information confirms that the distributions are good fits, and the resulting @RISK distribution functions are pasted into the model.

### Fit Historical Data to Distributions

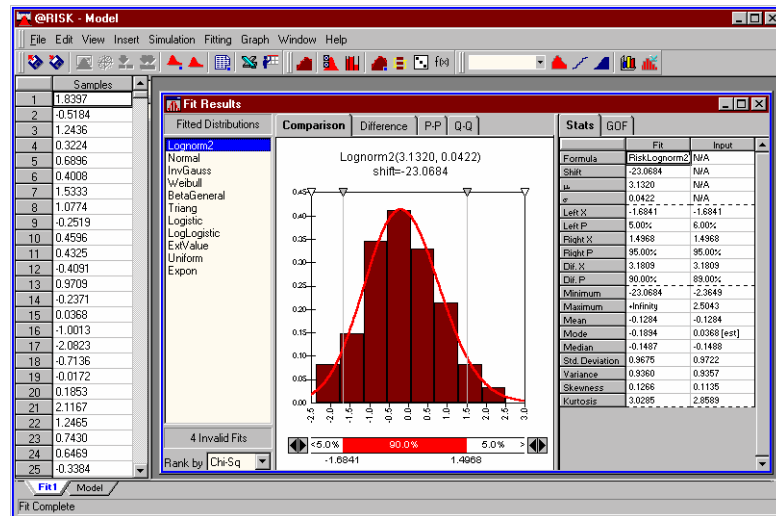

## Simulate with @RISK

Once all the @RISK functions are in place, the "Profit" cells are selected as outputs and a simulation is run. Overall, the results look promising. Although there will be losses initially, there is an 85% chance they will make an acceptable profit, and a 25% chance the venture will generate more revenue than they had initially assumed! The Excelsior 5000 project is given the go-ahead.

**@RISK**  
**Simulates Profit**  
**From Laptop**  
**Sales**

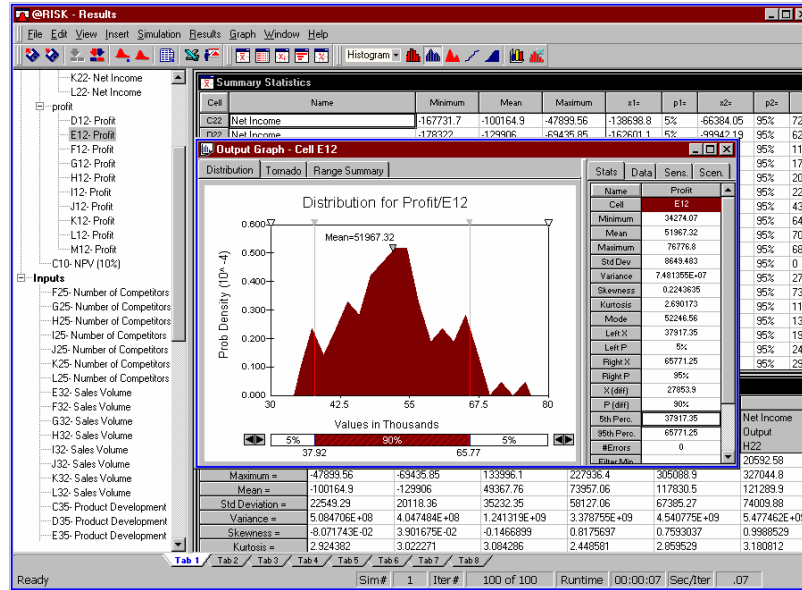

## Decide with PrecisionTree

Excelsior Electronics had assumed they would sell and distribute the Excelsior 5000 themselves. However they could use various catalogs and computer warehouses to distribute their product. A decision tree model is built using PrecisionTree, taking into account unit prices, sales volume, and other critical factors for direct sales versus catalog sales. A Decision Analysis is run and PrecisionTree suggests using catalogs and warehouses. Excelsior Electronics puts that plan into full motion.





# Introduction to @RISK

The techniques of Risk Analysis have long been recognized as powerful tools to help decision-makers successfully manage situations subject to uncertainty. Their use has been limited because they have been expensive, cumbersome to use, and have substantial computational requirements. The growing use of computers in business and science has offered the promise that these techniques can be used by all decision-makers.

That promise has been finally realized with @RISK (pronounced "at risk"), a system which brings these techniques to the industry standard modeling package, Microsoft Excel. With @RISK and Excel any risky situation can be modeled, from business to science and engineering. You are the best judge of what your analysis needs require, and @RISK, combined with the modeling capabilities of Excel, lets you design a model which best satisfies those needs. Anytime you face a decision or analysis under uncertainty, use @RISK to improve your picture of what the future could hold.

## @RISK for Excel

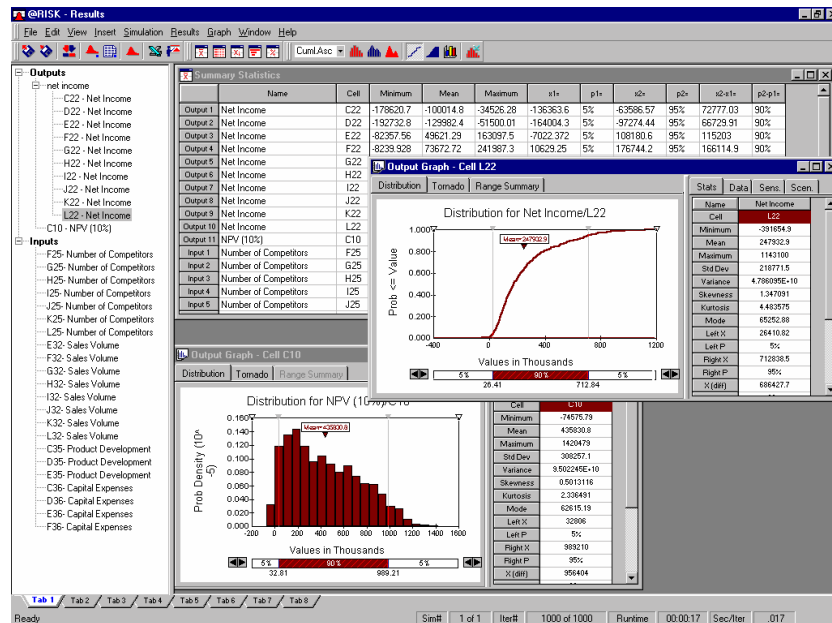

## Why You Need Risk Analysis and @RISK

Traditionally, analyses combine single point estimates of a model's variables to predict a single result. This is the standard Excel model, a spreadsheet with a single estimate of results. Estimates of model variables must be used because the values which actually occur are not known with certainty. In reality, however, many things just don't turn out the way that you have planned. Maybe you were too conservative with some estimates and too optimistic with others. The combined errors in each estimate often lead to a real-life result that is significantly different from the estimated result. The decision you made based on your expected result might be the wrong decision, and a decision you never would have made if you had a more complete picture of all possible outcomes. Business decisions, technical decisions, and scientific decisions all use estimates and assumptions. With @RISK, you can explicitly include the uncertainty present in your estimates to generate results that show all possible outcomes.

### **Monte Carlo Simulation**

@RISK uses a technique called Monte Carlo simulation to combine all the uncertainties you identify in your modeling situation. You no longer are forced to reduce what you know about a variable to a single number. Instead, you include all you know about the variable, including its full range of possible values and some measure of likelihood of occurrence for each possible value. @RISK uses all this information, along with your Excel model, to analyze every possible outcome. It's just as if you ran hundreds or thousands of What-if scenarios all at once! In effect, @RISK lets you see the full range of what could happen in your situation. It's as if you could live through your situation over and over again, each time under a different set of conditions, with a different set of results occurring.

All this added information sounds like it might complicate your decisions, but one of simulation's greatest strengths is its power of communication. @RISK gives you results that graphically illustrate the risks you face. This graphical presentation is easily understood by you, and easily explained to others.

### **When Should You Use @RISK?**

Anytime you make an analysis in Excel that could be affected by uncertainty, you can and should use @RISK. The applications in business, science and engineering are practically unlimited and you can use your existing base of spreadsheet models. An @RISK analysis can stand alone, or be used to supply results to other analyses. Consider the decisions and analyses you make every day. If you've ever been concerned with the impact of risk in these situations, you've just found a good use for @RISK!

## @RISK and Microsoft Excel

As an add-in to Microsoft Excel, @RISK links directly to Excel to add Risk Analysis capabilities. The @RISK system provides all the necessary tools for setting up, executing and viewing the results of Risk Analyses. And @RISK works in a style you are familiar with, Excel style menus and functions.

### **@RISK Functions**

Uncertain cell values in @RISK for Excel are defined as probability distributions using functions. @RISK adds over thirty new functions to the Excel function set, each of which specifies a different distribution type for cell values. Distribution functions can be added to any number of cells and formulas throughout your worksheets and can include arguments which are cell references and expressions, allowing extremely sophisticated specification of uncertainty.

### **Available Distribution Types**

The probability distributions provided by @RISK specify nearly any type of uncertainty in cell values in your spreadsheet. A cell containing the distribution function `NORMAL(10,10)`, for example, returns samples during a simulation drawn from a normal distribution (mean = 10, standard deviation = 10). Distribution functions are only invoked during a simulation — in normal Excel operations, they show a single cell value — just the same as Excel before @RISK.



# Using PrecisionTree With @RISK

@RISK is a perfect companion to PrecisionTree. @RISK allows you to 1) quantify the uncertainty that exists in the values and probabilities which define your decision trees, and 2) more accurately describe chance events as a continuous range of possible outcomes. Using this information, @RISK performs a Monte-Carlo simulation on your decision tree, analyzing every possible outcome and graphically illustrating the risks you face.

## ***Using @RISK to Quantify Uncertainty***

With @RISK, all uncertain values and probabilities for branches in your decision trees and supporting spreadsheet models can be defined with distribution functions. When a branch from a decision or chance node has an uncertain value, for example, this value can be described by an @RISK distribution function. During a normal decision analysis, the expected value of the distribution function will be used as the value for the branch. The expected value for a path in the tree will be calculated using this value.

However, when a simulation is run using @RISK, a sample will be drawn from each distribution function during each iteration of the simulation. The value of the decision tree and its nodes will then be recalculated using the new set of samples and the results recorded by @RISK. A range of possible values will then be displayed for the decision tree. Instead of seeing a risk profile with a discrete set of possible outcomes and probabilities, a continuous distribution of possible outcomes is generated by @RISK. You can see the chance of any result occurring.

## ***Describing Chance Events as a Continuous Range of Possible Outcomes***

In decision trees, chance events must be described in terms of discrete outcomes (a chance node with a finite number of outcome branches). But, in real life, many uncertain events are continuous, meaning that any value between a minima and maxima can occur.

Using @RISK with PrecisionTree makes modeling continuous events easier using distribution functions. And, @RISK functions can make your decision tree smaller and easier to understand!

## Methods of Recalculation During a Simulation

Two options are available for recalculation of a decision model during a simulation performed with @RISK. These are set using the @RISK command in the Decision Tree or Influence Diagram settings dialog box. The first option, *Expected Values of the Model*, causes @RISK to first sample all distribution functions in the model and supporting spreadsheets each iteration, then recalculate the model using the new values to generate a new expected value. Typically the output from the simulation is the cell containing the expected value of the model. At the end of the run an output distribution reflecting the possible range of expected values for the model and their relative likelihood of occurrence is generated.

The second option, *Values of One Sampled Path Through the Model*, causes @RISK to randomly sample a path through the model each iteration of a simulation. The branch to follow from each chance node is randomly selected based on the branch probabilities entered. This method does not require that distribution functions be present in the model; however, if they are used a new sample is generated each iteration and used in path value calculations. The output from the simulation is the cell containing the value of the model, such as the value of the root node of the tree. At the end of the run an output distribution reflecting the possible range of out values for the model and their relative likelihood of occurrence is generated.

## Using Probability Distributions in Nodes

Remember the Oil Drilling model in *Chapter 4: An Overview to PrecisionTree*? Let's take another look at one of the chance nodes in the model:

### Drilling Decision for Open Test Results

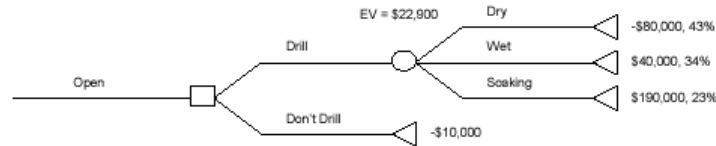

The results of drilling are divided into three discrete outcomes (Dry, Wet and Soaking). But, in reality, the amount of oil found should be described with a continuous distribution. Suppose the amount of money made from drilling follows a lognormal distribution with a mean of \$22900 and a standard deviation of \$50000, or the @RISK distribution =RiskLognorm(22900,50000).

To use this function in the oil drilling model, change the chance node to have only one branch, and the value of the branch is defined by the @RISK function. Here's how the new model should look:

**Drilling Decision  
With a  
Probability  
Distribution**

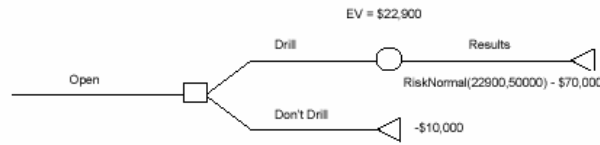

During an @RISK simulation, the RiskLognorm function will return random values for the payoff value of the Results node and PrecisionTree will calculate a new expected value for the tree.

**Decision  
Forcing During  
Simulation**

But, what about the decision to Drill or Not Drill? If the expected value of the Drill node changes, the optimum decision could change iteration to iteration. That would imply that we know the outcome of drilling before the decision is made. To avoid this situation, click *Decisions Follow Current Optimal Path* option in the @RISK dialog before running an @RISK simulation. Every decision node in the tree will be changed to a forced decision node, which causes each decision node to select the decision that's optimal when the command is used. This avoids changes in a decision due to changing a decision tree's values and probabilities during a risk analysis.

**Using @RISK to Analyze Decision Options**

**Value of Perfect  
Information**

There may be times when you want to know the outcome of a chance event before making a decision. You want to know the value of perfect information.

Before running a risk analysis, you know the expected value of the Drill or Don't Drill decision from the value of the Drill Decision node. If you ran a risk analysis on the model without forcing decisions (i.e., the *Decisions May Change Each Iteration* option is selected), the return value of the Drill Decision node would reflect the expected value of the decision *if you could perfectly predict the future*. The difference between the two values is the highest price you should pay (perhaps by running more tests) to find out more information before making the decision.

**Selecting @RISK Outputs**

Running a risk analysis on a decision tree can produce many types of results, depending on the cells in your model you select as outputs. True expected value, the value of perfect information, and path probabilities can be determined.

**Start Node**

Select the value of a start node of a tree (or the beginning of any subtree) to generate a risk profile from an @RISK simulation. Since @RISK distributions generate a wider range of random variables, the resulting graph will be smoother and more complete than the traditional discrete risk profile.

**Decision Node**

If you want to calculate the value of perfect information for a decision, don't select *Decisions Follow Current Optimal Path* - select *Decisions May Change Each Iteration* instead. Select the decision node you are interested in as an @RISK output and run a simulation. After the simulation, find the expected value of the output (from the @RISK window) and subtract the node's original expected value from it. The result is the value of perfect information.



# Introduction to TopRank

TopRank is the ultimate What-if tool for spreadsheets from Palisade Corporation. TopRank greatly enhances the standard What-if and data table capabilities found in your spreadsheet. In addition, you can easily step up to powerful risk analysis with its companion package, @RISK.

## **TopRank and What-if Analysis**

TopRank helps you find out which spreadsheet value(s) or variable(s) affects your results the most — an automated What-if or sensitivity analysis. You also can have TopRank automatically try any number of values for a variable — a data table — and tell you the results calculated at each value. TopRank also tries all possible combinations of values for a set of variables (a Multi-Way What-if analysis), giving you the results calculated for each combination.

## **TopRank for Excel**

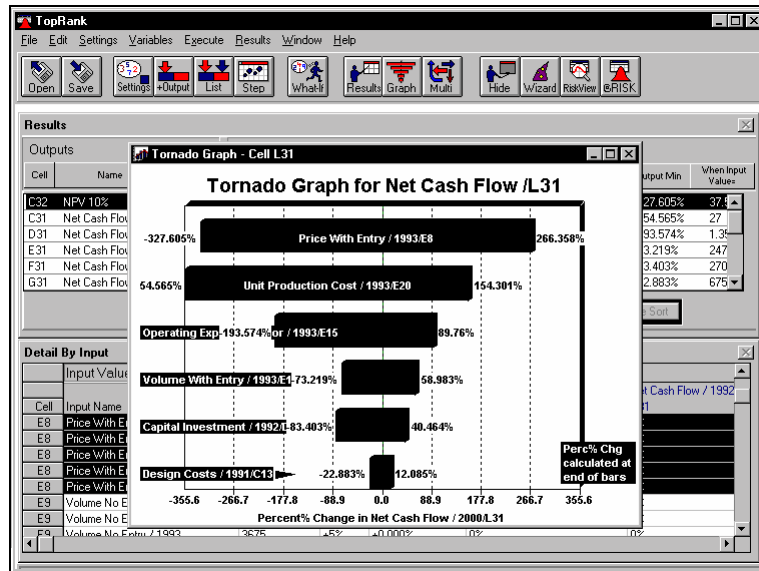

Running a What-if or sensitivity analysis is a key component of making any decision based on a spreadsheet. This analysis identifies which variables affect your results the most. This shows you those factors you should be most concerned with as you 1) gather more data and refine your model and 2) manage and implement the situation described by the model.

TopRank is a spreadsheet add-in for Microsoft Excel. It can be used with any pre-existing or new spreadsheet. To set up your What-if analyses, TopRank adds new custom “Vary” functions to the spreadsheet function set. These functions specify how the values in your spreadsheet can be varied in a What-if analysis; for example, +10% and -10%, +1000 and -500, or according to a table of values you’ve entered.

TopRank can also run a fully automatic What-if analysis. It uses powerful auditing technology to find all possible values in your spreadsheet which could affect your results. It can then change all these possible values automatically and find out which is most significant in determining your results.

**TopRank  
Applications**

TopRank applications are the same as spreadsheet applications. If you can build your model in a spreadsheet, you can use TopRank to analyze it. Businesses use TopRank to identify the critical factors — price, up front investment amount, sales volume or overhead — that most affect the success of their new product. Engineers use TopRank to show them the individual product components whose quality most affects final product production rates. A loan officer can have TopRank quickly run her model at all possible interest rate, loan principle amount and down payment combinations and then review results for each possible scenario. Whether your application is in business, science, engineering, accounting or another field, TopRank can work for you to identify the critical variables which affect your results.

**Modeling Features**

**Why TopRank?**

As an add-in to Microsoft Excel, TopRank links directly to Excel to add What-if analysis capabilities. The TopRank system provides all the necessary tools for conducting a What-if analysis on any spreadsheet model. And TopRank works in a style you are familiar with — Excel style menus and functions.

What-if analysis and Data Tables are functions that can be performed directly in your spreadsheet, but only in a manual, unstructured format. Simply changing a cell value in your spreadsheet and calculating a new result is a basic What-if analysis. And a Data Table which gives a result for each combination of two values can also be built in your spreadsheet. TopRank, however, performs these tasks automatically and analyzes their results for you. It instantly performs What-if’s on all possible values in your spreadsheet which could affect your result, instead of requiring you to change values individually and recalculate results. It then tells you what spreadsheet value is most significant in determining your result.

**Multi-Way  
What-if Analysis**

TopRank also runs data table combinations automatically, without requiring you to set up tables in your spreadsheet. Combine more than two variables in its Multi-Way What-if analysis — you can generate combinations of any number of variables — and rank your combinations by their affect on your results. You can perform these sophisticated and automated analyses quickly, as TopRank keeps track of all the values and combinations it tries, and their results, separate from your spreadsheet. By taking an automated approach, TopRank gives you What-if and Multi-Way What-if results almost instantly. Even the least experienced modeler can get powerful analysis results.

**TopRank  
Functions**

TopRank defines variations in spreadsheet values using functions. To do this, TopRank has added a set of new functions to the Excel function set, each of which specifies a type of variation for your values. These functions include:

- ◆ **Vary and AutoVary** functions which, during a What-if analysis, change a spreadsheet value across a + and - range you define.
- ◆ **VaryTable** functions which, during a What-if analysis, substitute each of a table of values for a spreadsheet value.

TopRank uses functions to change spreadsheet values during a What-if analysis and keeps track of the results calculated for each value change. These results are then ranked by the amount of change from the original expected results. Then, functions which caused the greatest change are identified as the most critical to the model.

TopRank Pro also includes over 30 probability distribution functions found in @RISK. These functions can be used along with Vary functions to describe variation in spreadsheet values.

**How are  
TopRank  
Functions  
Entered?**

TopRank functions are entered wherever you want to try different values in a What-if analysis. The functions can be added to any number of cells in a spreadsheet and can include arguments which are cell references and expressions — providing extreme flexibility for defining the possible variation of values in your spreadsheet models.

In addition to adding Vary functions yourself, TopRank can automatically enter Vary functions for you. Use this powerful feature to quickly analyze your spreadsheets without manually identifying values to vary and typing in functions.

***Automated  
What-if's***

When automatically entering Vary functions, TopRank traces back through your spreadsheet and finds all possible values which could affect the result cell you identify. As it finds a possible value, it substitutes in an "AutoVary" function with the default variation parameters (such as +10% and -10%) you've selected. With a set of AutoVary functions inserted, TopRank can then run its What-if analysis and rank the values which could affect your results in order of their importance.

With TopRank, you can step through your Vary and AutoVary functions and change the variation each function specifies. As a default you can use a -10% and +10% variation, but for a certain value you may feel that a -20% and +30% change is possible. You can also select to not have a value varied — as in some cases a spreadsheet value is fixed and could never be changed.

***Running a  
What-if Analysis***

During its analysis, TopRank individually changes values for each Vary function and recalculates your spreadsheet using each new value. Each time it recalculates, it collects the new value calculated in each result cell. This process of changing value and recalculating is repeated for each Vary and VaryTable function. The number of recalculations performed depends on the number of Vary functions entered, the number of steps (i.e., values across the min-max range) you want TopRank to try for each function, the number of VaryTable functions entered, and the values in each table used.

***TopRank  
Results***

TopRank ranks all varied values by their impact on each result cell or output you've selected. Impact is defined as the amount of change in the output value that was calculated when the input value was changed. If, for example, the result of your spreadsheet model was 100 prior to changing values, and the result was 150 when an input changed, there is a +50% change in results caused by changing the input.

TopRank results can be viewed graphically in Tornado, Spider or Sensitivity graph. These graphs summarize your results to easily show the most important inputs for your results.

# Using PrecisionTree With TopRank

PrecisionTree offers one and two-way sensitivity analyses. But what if you want to look at larger combinations of variables, or vary values using more sophisticated methods? TopRank has the capabilities to handle more sophisticated and thorough sensitivity analyses of a decision tree with its built in automatic sensitivity analysis, support for what-if tables and multi-way what-if capabilities.

## Using TopRank to Run Sensitivity Analyses

### ***Defining Outputs***

When using TopRank with PrecisionTree, you use the TopRank Add Output command to define the start node of a tree (or any sub-tree) as a TopRank output. TopRank will then automatically identify the values in your decision tree and supporting spreadsheet models which affect the tree's expected value. It then varies these values to determine how changes in them affect your results.

### ***Identifying Inputs***

When a TopRank output is selected, all values affecting that output are identified and Vary functions are substituted for these values. For example, if you select the value of a Start node of a tree as an output, TopRank traces thorough all the relationships in your tree and finds all values, such as branch probabilities and branch values, which could affect your output. In addition to identifying values located in the tree itself, TopRank scans supporting spreadsheet models to identify inputs in those models that are referenced in the decision tree. For all identified inputs, TopRank substitutes Vary functions that will be used in a what-if analysis.

### ***Running a What-if Analysis on a Decision Tree***

During its analysis, TopRank individually changes values for each Vary function and recalculates your decision tree using each new value. Each time it recalculates, it collects the new value calculated for each output, such as a new expected value for the tree. This process of changing values and recalculating is repeated for each Vary and VaryTable function. The number of recalculations performed depends on the number of Vary functions entered, the number of steps (i.e., values across the min-max range) you want TopRank to try for each function, the number of VaryTable functions entered, and the values in each table used.

TopRank ranks all varied values by their impact on the expected value of the tree or the expected value of other nodes you've selected as outputs. Impact is defined as the amount of change in the output value that was calculated when the input value was changed. Your Tornado graph summarizes this ranking, showing which inputs were most critical in determining your decision analysis results.

**Using Tables of Values in a Sensitivity Analysis of Your Decision Tree**

TopRank includes a powerful function – VaryTable -- that allows you to calculate your decision tree's results for each value in a table of values.

Examples of VaryTable functions are:

- ◆ *=RiskVaryTable(100,{50,80,120,150,175})*
- ◆ *=RiskVaryTable(100,A1:A10)*

During a what-if analysis, TopRank will return each value from the entered or referenced table and calculate your decision tree's result using that value. If, for example, the first VaryTable function above was used in place of a branch value of 100 in your decision tree, TopRank would recalculate the decision tree using the values 50,80,120,150 and 175 as the branch value. TopRank would keep track of how each of these changes in branch value affected the expected value of the tree.

# Introduction to BestFit

Introducing BestFit, the program that fits your data to a selected statistical distribution and displays the results in high-resolution graphs.

## Who Should Use BestFit?

Anyone who works with data can use BestFit. You can apply it to business situations such as actuarial or claims adjustment, or to science and engineering problems such as oil well drilling or time between events. You can import data from your spreadsheet and export the results as graphic files to your report or presentation.

## Why Distribution Fitting?

So why fit data to a distribution? Because if you don't (or if you fit it to the wrong distribution), any analysis you run could have serious errors that can cost you time and money. If your data was generated by a random process, you'll get the best modeling results possible by accurately describing that process. And the best way to do that is with a fitted probability distribution.

## BestFit for Windows

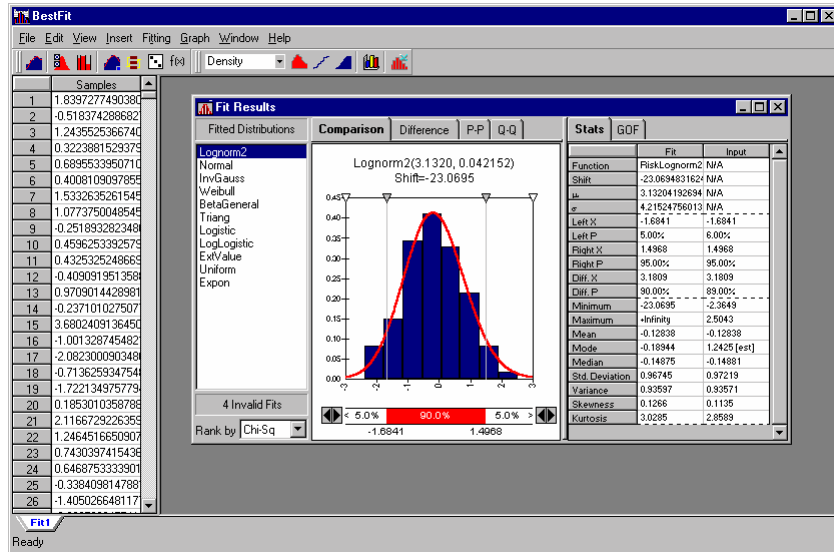

## **The Importance of Distributions**

Sometimes we hear analysts ask "Can't we just take the mean value of my data and use that in my model?" Or they ask "Why can't I just assume the data is normally distributed?" Numerous examples and case studies have been performed to show that using a single value, like the mean, can lead to serious errors. And blindly assuming any distribution type can be equally dangerous, particularly in modeling a process that extends over a significant length of time.



## Features

BestFit offers many features for calculating best fits and analyzing the results. These features include:

- ◆ *Twenty-eight available distribution functions*
- ◆ *Parameter selection using maximum-likelihood estimators*
- ◆ *Input up to 100,000 data points or pairs*
- ◆ *Filtering to remove outliers*
- ◆ *Complete statistics report, including goodness-of-fit, critical values and target values*
- ◆ *Presentation quality graphs displayed in BestFit or transferred automatically to Excel's native format*
- ◆ *On-Line help and tutorial*



# Using PrecisionTree With BestFit

BestFit was developed by Palisade as a companion product for @RISK and it fully integrated into @RISK Professional and Industrial versions. When working with PrecisionTree, you'll use BestFit when setting up and running risk analyses of decision trees using @RISK. You also can use BestFit to assist you in selecting probability distributions for use in PrecisionTree's distributed chance nodes.

## BestFit and Distributed Chance Nodes

A distributed chance node uses a probability distribution function to specify the branch probabilities for a chance node. As branch values are entered in the range of the selected distribution function, probability values are returned based on the density function for that distribution. This allows you to insure that the probabilities you enter for each branch of a chance node reflect the shape of a specific probability distribution.

But how do you select which distribution to use when entering a distributed chance node? This is where BestFit comes in. You may, for example, need to specify a set of possible branches for a chance node named Oil Field Size. By taking a data set containing the sizes of other oil fields found in your region and fitting that data using BestFit, you can generate a probability distribution function for Oil Field Size. This distribution function can be entered in the *Distributed Probabilities* option in the *Branch Definition* dialog box in PrecisionTree and probabilities for several possible oil field sizes can be selected from that distribution.

## BestFit and Risk Analyses

The results of your risk analyses can be extremely sensitive to your choice of distributions. A poor choice of distributions can lead to serious errors in your results, errors that can cost you time and money. If you have data, there's no excuse for not trying to properly fit it to the best distribution. But doing this manually is a hopelessly time consuming job, and it still might not lead you to the best fit.

### **Who Should Use BestFit?**

What if you don't have much data? You still can benefit from BestFit. @RISK's Sensitivity analysis can help you identify critically important input variables. You can then focus your attention on these variables to try to get more data. Then use this new data in BestFit to pick distributions. @RISK and BestFit teamed up together like this just might make the difference between a successful project and a failure.

**@RISK  
Formulas**

The results of all BestFit analyses can be displayed in @RISK's function format. Just fit, cut and paste to place your BestFit results in your model. And, with BestFit's spreadsheet linking abilities, your data never has to leave your spreadsheet!

# Introduction to RISKview

RISKview helps you select a distribution function by previewing different distributions and parameters before introducing them to your model. Then, at the click of the button, RISKview writes the selected formula to your model.

RISKview also includes the Distribution Artist, a tool which extracts data points from a probability curve that you draw. RISKview can also run a quick distribution fitting routine to find the distribution that is the best fit for that curve.

## RISKview for Windows

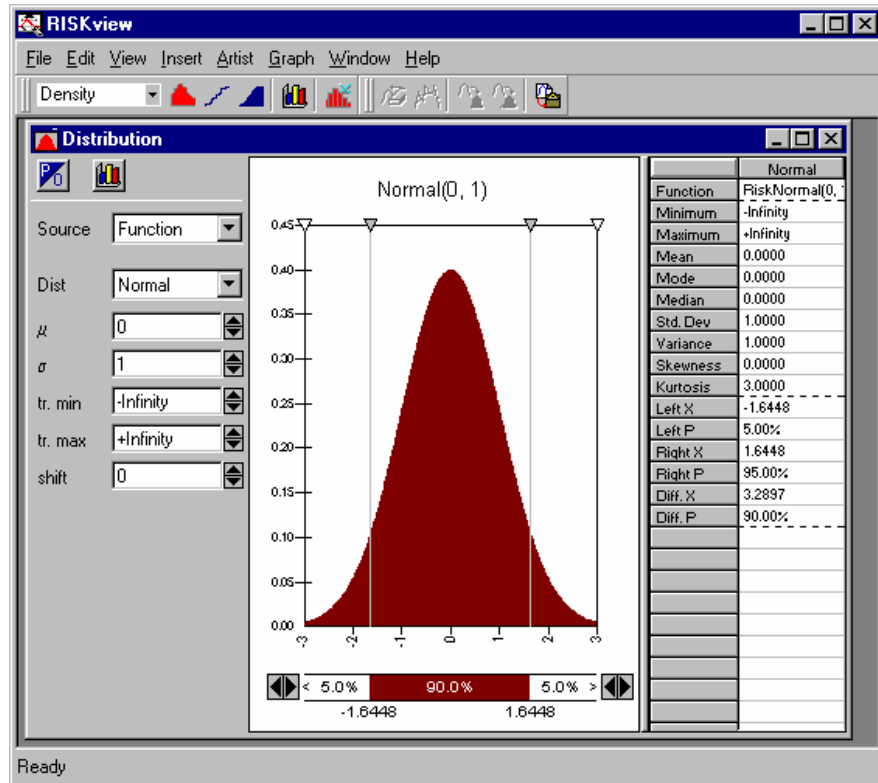

## Why You Need RISKview

RISKview takes the guess-work out of selecting a distribution by letting you visually assess the curve. Not sure how changing a parameter affects the shape of a curve? RISKview shows you. Want to know the vital statistics of the distribution before running a simulation? RISKview tells you. Do you have a mental image of what the curve should look like? RISKview translates your drawing to an @RISK distribution function.

RISKview is great if you're just learning about distribution functions, but advanced users will find it useful too. We have all experienced times when we know what we want a distribution to look like, but we don't know how to translate that mental image to a distribution function. RISKview lets you to visualize a distribution function before introducing it to your model.

### ***Distribution Functions***

RISKview previews over 30 probability distribution functions, all available in @RISK and TopRank Pro. And, RISKview tells you the vital statistics for each function, including mean, mode, variance, skewness and kurtosis.

### ***Distribution Artist***

Do you want to create your own probability distribution? Draw your own curve using the Distribution Artist and let RISKview create a GENERAL distribution function from the drawing. A smoothing algorithm insures that shaky hands don't affect the final distribution.

### ***Distribution Fitting***

RISKview also contains a limited version of our popular software, BestFit. After drawing a curve in the Distribution Artist, click the Fit Curve icon to find a distribution function that fits your curve.

## Using PrecisionTree with RISKview

Probability assessment is an important part of designing a model. Yet, many people don't know where to begin when selecting a probability distribution function. That's where RISKview can help. By providing a visual representation of a distribution function and letting you modify the curve to the exact shape you need, RISKview insures that the probability distributions in your model define your uncertain situations accurately.

We recommend using RISKview when using PrecisionTree with @RISK. Once you've chosen a distribution function in RISKview, click Apply and the formula for the chosen distribution is written to the selected cell.

Run a simulation as you usually do. Because you've defined your uncertainty more accurately, your results will be better — leading to more decision making power.





---

# Appendix E: Glossary of Terms

<b>@RISK</b>	Pronounced "at risk," a risk analysis add-in for Microsoft Excel from Palisade Corporation.
<b>Arcs</b>	Arrows connecting nodes in an influence diagram indicating a dependency between the two nodes. Arcs to chance nodes represent relevance while arcs to decision nodes represent the flow of information.
<b>Barren Node</b>	A node which has no effect on the decision to be made. In an influence diagram the node has predecessors but no successors.
<b>Base Case</b>	The state of a decision model before a sensitivity analysis is run, when all variables are set to their most likely value.
<b>Bayes' Theorem</b>	An algebraic formula that describes the relationship among the probabilities of dependent events. In decision analysis, Bayes' theorem is used to reorder (or "flip") two chance nodes in a decision model.
<b>Branch</b>	In a decision tree, a branch is drawn for each possible outcome of a decision or chance event.
<b>Chance Node</b>	A circle representing an event which the decision maker has no control over. Each outcome of the event has a corresponding value and probability.
<b>Certainty Equivalent</b>	The value you place on a uncertain situation, or the amount of money that you would accept to avoid a risky situation. In a decision tree, the certainty equivalent is calculated from the expected utility using the inverse of the utility function. <i>See Utility Function, Expected Utility.</i>
<b>Collectively Exhaustive</b>	No other possibilities exist for a node. <i>See Mutually Exclusive.</i>
<b>Conditional Arc</b>	Arc pointing into a chance or payoff nodes. Conditional arcs do not represent causality and are reversible by Bayes' Theorem. <i>See Informational Arc.</i>
<b>Conditional Independence</b>	Two nodes are conditionally independent given a third node if and only if the outcomes of the two nodes depend only the outcome of the third node and not on each other.
<b>Constant Risk Aversion</b>	A situation where the decision maker views a risky situation the same way no matter how much money he has. <i>See Decreasing Risk Aversion, Utility Function.</i>

<b>Cumulative Risk Profile</b>	A distribution function that shows the probability that the outcome of the model is less than or equal to a specified value. <i>See Risk Profile.</i>
<b>Cycle</b>	In an influence diagram, a "loop" of arcs in which there is no clear endpoint. Cycles should be avoided in your decision models.
<b>Decision Analysis</b>	The process of modeling a problem situation, taking into account the decision maker's preferences and beliefs regarding uncertainty, in order to gain insight and understanding. Decision Analysis provides a systematic method for describing problems.
<b>Decision Node</b>	A square representing an event where the decision maker must choose one of a number of options. Each option has a value associated with it.
<b>Decision Tree</b>	A graphical representation of a problem describing chance events and decisions in chronological order. Events "branch" from their successors, making the final model look like a tree. Traditionally, decision trees begin with a decision node.
<b>Decreasing Risk Aversion</b>	A situation where risk becomes more attractive when the decision maker has more money. <i>See Constant Risk Aversion, Utility Function.</i>
<b>Deterministic</b>	A value or variable with no associated uncertainty. <i>See Stochastic, Risk.</i>
<b>Deterministic Dominance</b>	A situation where the dominating alternative pays off at least as much as the one that is dominated.
<b>Deterministic Sensitivity Analysis</b>	A sensitivity analysis where the variable is a payoff related to an event or events. <i>See Probabilistic Sensitivity Analysis.</i>
<b>End Node</b>	A triangle which represents the termination point of a branch on a decision tree.
<b>Event</b>	An outcome or group of outcomes that might result from a given action. Usually refers to the possible outcomes of a chance node.
<b>Event Tree</b>	A tree which begins with a chance node.
<b>Expected Utility</b>	The weighted average of the utility units for each outcome in a chance node. <i>See Utility Function.</i>
<b>Expected Value (EV)</b>	Weighted average of possible outcomes for a chance node or for an entire decision model.

<b>Fault Tree</b>	An event tree showing the relationship of prior events to an event in question, often the failure of some complicated system. Typically, fault trees contain only chance nodes.
<b>Independent Nodes</b>	In an influence diagram, if there are no arrows connecting two nodes, the nodes are independent if and only if the outcome of each node does not affect the outcome of the other.
<b>Influence Diagram</b>	A simple graphical representation of a problem which emphasizes the relationship between events. Although influence diagrams are less detailed than decision trees, they can show the "whole picture" in a way that is easy to explain to others.
<b>Informational Arc</b>	An arc pointing into a decision node. Informational arcs indicate time precedence and are not reversible. <i>See Conditional Arc.</i>
<b>Kurtosis</b>	A measure of the shape of a distribution indicating how flat or peaked the distribution is. The higher the kurtosis, the more peaked the distribution.
<b>Logic Node</b>	Similar to a decision node. Allows the decision maker to select the optimum choice by evaluating the logical expression of each child from top to bottom and selecting the first non-zero branch. If no expressions are non-zero, the last branch is chosen. Expressions at the nodes are usually logical expressions such as $x > 5$ , $x = 2$ , etc.
<b>Minimum</b>	The lowest possible value that a variable can reasonably have.
<b>Most Likely Value</b>	The outcome with the highest probability of occurrence. In a Risk Profile, the most likely value is the value corresponding to the highest bar in the graph.
<b>Mutually Exclusive</b>	Only one outcome can occur at a node. <i>See Collectively Exhaustive.</i>
<b>Objective Risk</b>	A probability value or distribution that is determined by "objective" evidence or accepted theory. The probabilities associated with an objective risk are known with certainty. <i>See Subjective Risk.</i>
<b>One-Way Sensitivity Analysis</b>	An analysis of the effect of a single variable on the outcome of a model. Results are typically displayed in a One-Way Sensitivity Graph. <i>See Sensitivity Analysis.</i>
<b>One-Way Sensitivity Graph</b>	A graph comparing a variable against the expected value of a model as the value of the variable ranges from its lower to upper bound. <i>See Sensitivity Analysis, One-Way Sensitivity Analysis.</i>
<b>Oriented Diagram</b>	An influence diagram that contains a payoff node. <i>See Influence Diagram.</i>

<b>Payoff Node</b>	A rectangle with rounded corners which represents the payoff of a decision on an influence diagram.
<b>Policy Suggestion</b>	An outline of the optimum decision path in a model, the results of a decision analysis.
<b>Predecessor Node</b>	The node directly before the selected node. <i>See Successor Node.</i>
<b>Probabilistic Dominance</b>	Occurs when the preferred alternative pays the same as the other with a greater probability of payoff. <i>See Stochastic Dominance.</i>
<b>Probabilistic Sensitivity Analysis</b>	A sensitivity analysis where the variable is the probability of a chance occurrence or occurrences. <i>See Deterministic Sensitivity Analysis.</i>
<b>PrecisionTree</b>	The decision analysis add-in for Microsoft Excel described in this User's Guide.
<b>Probability</b>	A measure of how likely a value or event is to occur.
<b>Proper Diagram</b>	An influence diagram that is an unambiguous representation of a single decision maker's view of the world.
<b>Reduction</b>	The act of representing the probability distribution for the objective function of an entire model as a single chance variable.
<b>Reference Node</b>	A diamond representing an event describe by a separate decision tree.
<b>Risk</b>	Uncertainty or variability in the outcome of some event or decision. In many cases the range of possible outcomes can include some that are perceived of as undesirable along with others that are perceived as desirable. The range of outcomes is often associated with levels of probability of occurrence.
<b>Risk Analysis</b>	Any method used to study and understand the risk inherent to a situation of interest. Methods can be quantitative and/or qualitative in nature.
<b>Risk Averse</b>	An attitude toward risky situations where a decision maker is less likely to chose a situation with a higher payoff if it includes a proportionately higher risk. There are situations where individuals may display the opposite behavior; they are risk takers. <i>See Risk Neutral.</i>
<b>Risk Neutral</b>	A decision maker who always selected the alternative with a higher payoff, regardless of risk. <i>See Risk Averse, Bayesian.</i>

<b>Risk Premium</b>	The difference between the expected value and the certainty equivalent of an uncertain event, or the amount of money you are willing to give up to avoid risk. <i>See Expected Value, Certainty Equivalent.</i>
<b>Risk Profile</b>	A distribution function that shows the probability that an outcome may occur, shows the uncertainty of the model. <i>See Cumulative Risk Profile.</i>
<b>Risk Tolerance</b>	A constant measuring the decision maker's attitude towards risk, is a parameter in the utility function. <i>See Utility Function.</i>
<b>Sensitivity Analysis</b>	A determination of which variables matter most in a decision (are most critical) by examining the impact of reasonable changes in base-case assumptions. Sensitivity analysis is useful for finding variable that have little impact on the final decision so that they may be treated deterministically. <i>See TopRank.</i>
<b>Skewness</b>	A measure of the shape of a distribution indicating the degrees of asymmetry in a distribution. Skewed distributions have more values on one side of a peak or most likely value - one tail is much longer than the other. A skewness of zero indicates a symmetric distribution, negative and positive skewness values indicate distributions that are skewed to the left and right, respectively. <i>See Kurtosis.</i>
<b>Spider Graph</b>	A graph showing the reasonable limits of change for each independent variable and the unit impact of these changes on the expected value of a model.
<b>Standard Deviation</b>	The square root of the variance. <i>See Variance.</i>
<b>Stochastic</b>	Uncertain or risky. <i>See Risk, Deterministic.</i>
<b>Stochastic Dominance (First Order)</b>	Occurs when two profiles on a cumulative risk profile do not cross and there is space between them. There are two forms of stochastic dominance. The first, called payoff, occurs when the preferred alternative pays more than the other with an equal probability of payoff. The second, called probability, occurs when the preferred alternative pays the same as the other with a greater probability of payoff. Stochastic dominance can contain a combination of both forms, but the dominant alternative always has a higher expected value.

<b>Strategy Region Graph</b>	Created after a two-way sensitivity analysis, a strategy region graph shows regions for which different strategies are optimal and provides guidance in determining how much effort is needed to model uncertainty in a decision problem. Demonstrates the extent to which the decision is sensitive to uncertainty.
<b>Subjective Risk</b>	A probability value or distribution determined by an individual's best estimate based on personal knowledge, expertise, and experience. New information often causes changes in such estimates and reasonable individuals may disagree on such estimates. <i>See Objective Risk.</i>
<b>Successor Node</b>	The node directly after the selected node. <i>See Predecessor Node.</i>
<b>TopRank</b>	Sensitivity analysis add-in for Microsoft Excel by Palisade Corporation.
<b>Tornado Graph</b>	Created after a one-way sensitivity analysis, a Tornado Graph shows how much the value of an alternative can vary with changes in a specific quantity when all other variables remain at their base values.
<b>Two-Way Sensitivity Analysis</b>	An analysis of the impact of two simultaneously changing variables on the outcome of a model. <i>See Sensitivity Analysis.</i>
<b>Two-Way Sensitivity Graph</b>	Created after a two-way sensitivity analysis, a two-way Sensitivity Graph shows regions where the expected value of the model is greater than a specified target value.
<b>Uncertainty</b>	<i>See Risk.</i>
<b>Uncertainty Node</b>	Node representing an event with an uncertain outcome. <i>See Chance Node.</i>
<b>Utility Function</b>	An expression that measures risk by converting the payoffs related to an outcome to utility units. The utility of one decision is then compared to that of another decision to select the optimum decision.
<b>Value Sensitivity Analysis</b>	Measuring the effects of model inputs on the decision policy by varying any value in the model and examining the effects on the optimal policy and expected value.
<b>Variable</b>	A basic model component that can take on more than one value. If the value that actually occurs is not known with certainty, the variable is considered uncertain. Usually a variable is found in a cell or named range in your model.
<b>Variance</b>	A measure of how widely dispersed the values are in a distribution, and thus is an indication of the "risk" of the distribution. It is calculated as the average of the squared deviations about the mean. The variance gives disproportionate weight to "outliers," values that are far away from the mean. <i>See Standard Deviation.</i>







---

# Index

## @

@RISK, iii, 79, 98, 104, 107, 108,  
118, 119, 141, 142, 143, 144,  
145, 146, 147, 149, 177, 178,  
179, 180, 181, 183, 184, 185,  
187, 188, 189, 190, 191, 193,  
201, 202, 204, 205, 207

## A

About Command, 138  
Authorization, 7, 138  
Automatically Update Links,  
107

## B

Barren Nodes, 19  
Bayes' Theorem, 155  
BestFit, 177  
**BETA**, 149  
**BETASUBJ**, 149  
Branch Definition, 113  
Branch Payoff Formulas, 89

## C

*Calculation nodes*, 58  
Certainty Equivalent, 168  
Chance Node, 53, 58, 114, 207,  
212  
**CHISQ**, 149  
Collapse and Expand, 111  
**COLLECT**, 152  
Conditional Arcs, 18  
Copy and Paste, 110

correlation, 152  
**CORRMAT**, 152  
Create New Influence Arc Icon,  
102  
Create New Submenu -  
Influence Diagram or Node  
Command, 101  
Create New Submenu - Tree  
Command, 100  
**CUMUL**, 149  
cumulative distribution, 149  
Cumulative Payoff  
Calculations, 115  
Cumulative Risk Profile, 127  
Cumulative Risk Profile Graph,  
69, 127  
**CurrentIter**, 147  
**CURRENTITER**, 154  
**CurrentSim**, 147  
**CURRENTSIM**, 154  
Custom Keywords, 116

## D

Decision Analysis, i, ii, 3, 13, 15,  
41, 46, 49, 57, 67, 97, 126, 127,  
128, 157, 175, 176, 181, 208  
Decision Forcing During  
Simulation, 108, 189  
Decision Node, 50, 190, 208  
DecisionTools Suite, 8, 43, 177,  
178  
**DEPC**, 152  
Distribution (Fixed Pb), 114  
Distribution (Fixed Val), 114  
Distribution Functions, 141  
Distribution Property  
Functions, 144

**DUNIFORM**, 149

## **E**

End Node Payoff Formula, 90  
Entering Arguments, 145  
entering distribution functions,  
142  
**ERF**, 149  
**ERLANG**, 149  
**EXPON**, 149  
Exponential Utility Function,  
169  
**EXTVALUE**, 150

## **F**

Forced Branch, 108, 113, 116

## **G**

**GAMMA**, 150  
**GENERAL**, 150  
**GEOMET**, 150  
Graph Options Dialog, 136

## **H**

**HISTOGRAM**, 150  
**HYPERGEO**, 150

## **I**

Ignore Branch Values, 115  
**INDEP**, 152  
**INVGAUSS**, 150

## **L**

Link Branch Values To, Link  
Payoff Values From, 112  
Linked Trees, 77  
Logarithmic Utility Function,  
171  
Logic Nodes, 77  
**LOGISTIC**, 150  
**LOGLOGISTIC**, 150

**LOGNORM**, 150  
**LOGNORM2**, 150

## **N**

**NEGBIN**, 150  
Node Type, 120  
**NORMAL**, 150

## **O**

One-Way Sensitivity Analysis,  
71, 131

## **P**

Palisade Corporation, 178  
**PARETO**, 151  
Payoff Calculation, 106  
**PEARSON5**, 151  
**PEARSON6**, 151  
**PERT**, 151  
**POISSON**, 151  
Policy Suggestion, 128

## **R**

**RAYLEIGH**, 151  
Real-Time Decision Model  
Results, 67  
Reference Node, 210  
Reference Nodes, 79  
Risk Premium, 168  
Risk Profile, 127  
Risk Profiles, 28  
**RISKview**, 177

## **S**

Sensitivity Analysis, 129  
Sensitivity Analysis on  
Probabilities, 91  
Settings Command - Decision  
Tree Branch, 117  
Settings Command - Decision  
Tree Node Option, 110

Settings Command - Decision  
Tree Option, 104  
Settings Command - Influence  
Diagram, 118, 120, 123  
Settings Selection Dialog Box,  
103  
**SIMTABLE**, 151  
Simulation Output Functions,  
146  
Simulation Statistics Functions,  
147  
Spider Graph, 74  
Square-Root Utility Function,  
171  
Statistics Report, 68, 126  
Strategy Region Graph, 37, 72,  
132, 135, 212  
Strategy Region Graphs, 76  
Structure Influence, 124  
**STUDENT**, 151

## T

Timing Arcs, 18  
Timing Influence, 124  
**TopRank**, 177, 179

Tornado Graph, 35, 36, 73, 133,  
212  
Tornado Graphs, iii, 35, 36, 48  
**TRIANG**, 151  
**TRIGEN**, 151  
Two-Way Sensitivity Analysis,  
37, 75, 135, 212

## U

Update Links, 137  
Utility Functions, 105, 163, 167,  
169, 171, 172

## V

Value Influence, 124  
Value When Skipped, 122

## W

**WEIBULL**, 151

## Z

Zoom Selection, 137

