

USER 'S GUIDE

WONDER[®] Core

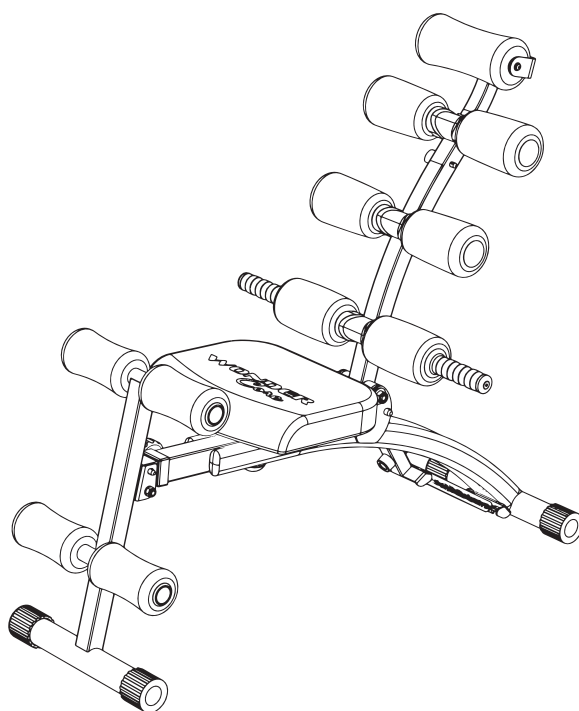

- ◆ Before you use the equipment, make sure you read the "Safety precautions", so you will use it properly.
- ◆ After reading, keep it in a safe place so you can refer to it at anytime.
- ◆ If you transfer the product to others, the user manual must go together.

Catalog

Safety precautions.....	1~2
Features.....	3
Accessories.....	4
Assembly.....	5~6
Start Use.....	7
How To Use.....	8~9
Storage & Maintenance.....	10



Safety Precautions

- You must read the "safety precautionary notes" before using the equipment.
- The cautionary notes recorded here refer to the importance of safety for which you must read.
- This equipment is in compliance with EN 957 part 2 class H (H = domestic)



Warning

 Must be Followed	<p>This product is suitable for healthy individuals as its target. You must consult your doctor before using this product.</p>
	<p>Warning: for your own safety, inspect your wonder core for damage and wear regularly and before each use especially on seat, springs, screws and knobs. If you find any missing or damaged parts, nicks, cuts, scratches or gouges in the wonder core, discontinue its use.</p>
	<p>Warning: Incorrect posture can cause injury. To avoid injury, follow the safety information in this manual. If you are new to wonder core, use 30 minutes a day at maximum is recommend, excessive training might cause muscle pain.</p>
	<p>Warning: Whenever you are adding or removing the spring, always remember to fix the seat back with the long pin.</p>
	<p>Please stop immediately if there is strange feeling or discomfort in the body during exercise. Possible harm to health.</p>
	<p>Do not use the equipment after drinking alcohol. Accident may occur or discomfort caused to the body so be sure these must be followed.</p>
	<p>Do not use the equipment right after meals (Avoid doing so within an hour after meals) Accident may occur or discomfort caused to the body so be sure these must be followed.</p>
	<p>Install the equipment in a place suitable for exercise. If the place is inappropriate, it may make you fall backwards or cause injury.</p>
	<p>Please use the equipment on level and hard grounds. If the place is inappropriate, it may make you fall backwards or cause injury.</p>

 **Warning**

 Use by Children Forbidden	<p>Never allow children to use the equipment unattended. May cause injuries</p>
	<p>Do not allow young children or pets to stay near you when the equipment is in use.</p>
 Do not disassemble	<p>Never repair or convert the equipment on your own. May cause abnormal movement or cause an accident. Contact the original dealer in case of failures or damages.</p>
 Confirmation	<p>Before using the equipment, make sure that the screws and knobs are tightly secured. May cause accidents like falling backwards or damage.</p>

 **Attention**

 Must be Followed	<p>Appropriate and fitting sportswear must be worn during its use. Otherwise, it may lead to injury or accident. If you have long hair, be sure to tie it up before each use. Otherwise it may be dragged into the sponge roller.</p>
	<p>Must warm up your body before exercise. Doing exercise before warming the body will be burden to the body.</p>
	<p>When exercise with the swing mode, hands must hold on the handle. You may otherwise fall or get injured.</p>
	<p>Always disassemble the springs and fold the equipment after each use. To avoid children using the equipment unattended.</p>
 Forbidden	<p>Do not use this product other than for its original purpose. Otherwise it may cause toppling, damage, malfunction or injury.</p>
	<p>Do not use exercise method not recorded in the manual. Otherwise it may lead to injury or accident.</p>
	<p>Do not let 2 people use the product at the same time. This product is for use by a single person. Otherwise it may cause accident or injury.</p>
	<p>Do not use the product for business purpose to allow an indefinite number of many individuals to use it. This product is limited to general household use. Otherwise it may cause injury or accident.</p>
	<p>When in use do not put your hands behind the seat back or under the seat.</p>

Features

INTRODUCING WONDER CORE, THE REVOLUTIONARY NEW WAY TO TIGHTEN YOUR CORE AND HAVE THE WONDERFUL SEXY SIX PACK ABS YOU HAVE ALWAYS WANTED.

- With Wonder Core, you're getting resistance on the way down and up with every rep. With dual resistance, you're getting double the workout in half the time!
- Wonder Core provides a full 180 degree range of motion. That means you can isolate and train your lower, middle, and upper abs---more range of motion means a much tighter core!
- Wonder Core is totally adjustable to your fitness level! You'll get the ideal amount of resistance on the way down and have the right amount of support customized to your exact fitness level coming up. That means everybody can do it!
- You can blast away your love handles with the built in Wonder Core twisting featured for a total core workout!
- Best of all, with Wonder Core, you're nestled in an ultra-comfortable seated position with your head and neck fully supported through the full range of motion.
- The thick foam cushion supports create an invigorating massage up and down your back as you train. This feels fantastic and will revitalize your spine and back so you walk away feeling wonder-ful!
- Wonder Core is even great for back pain! Its ergonomic arc design can fully stretch your back. You will feel incredible relief by simply laying on it.

Accessories

Main frame

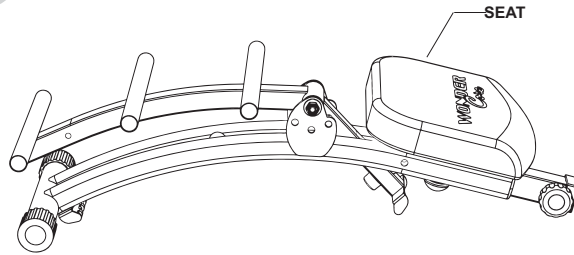

Parts

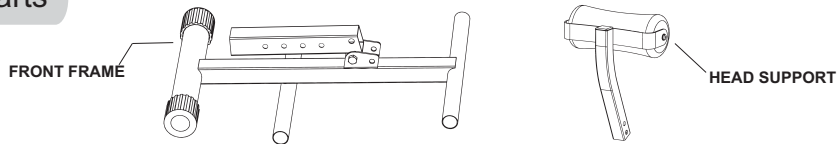

Accessories

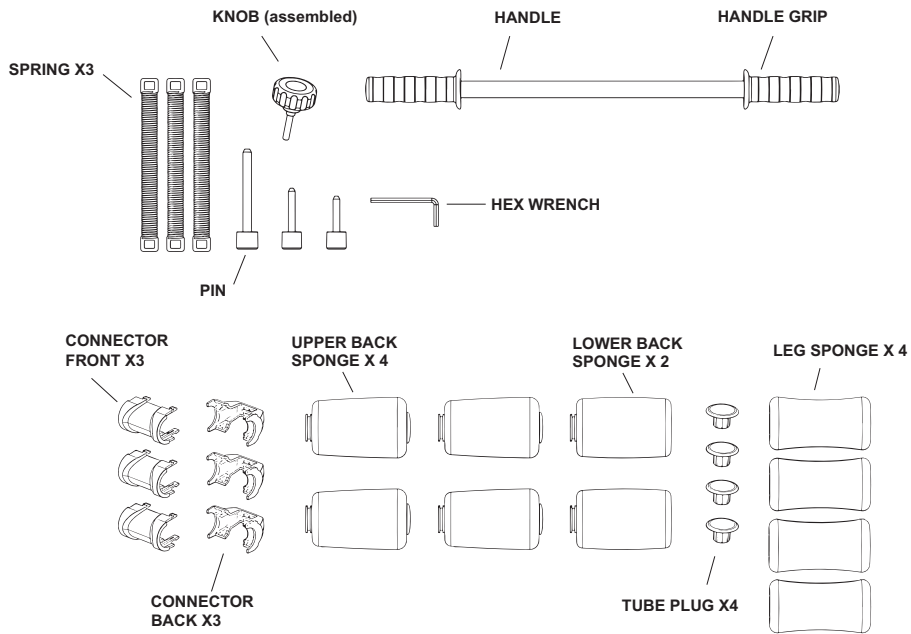

Assembly

Please confirm the accessories on the previous page to make sure there is no shortage.

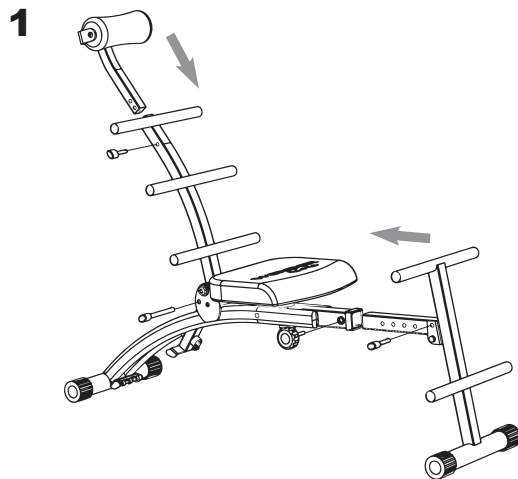

Assemble the parts

Insert the front frame into the main unit and fix it with knob and short pin.

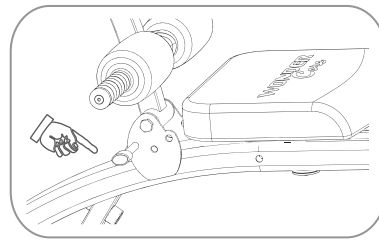

Unfold the seat back and fix it with the long pin.
Insert head support and fix it with the shortest pin.

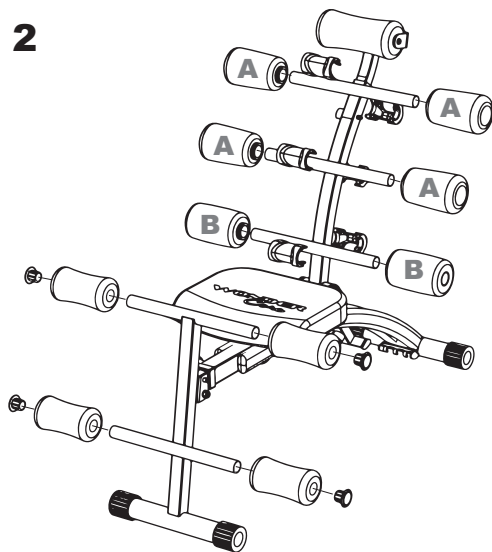

Assemble the sponges

Place the back sponges onto the main unit follow by the order.

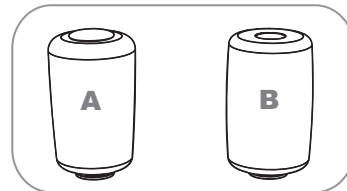

Assemble the connector, make sure it holds back sponges.
Assemble the leg sponges and tube plugs.
Tip. You can disassemble the connector if you mix up the order of back sponges.

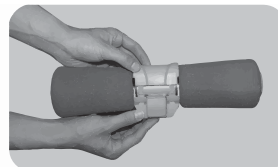
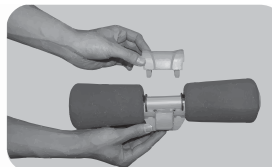
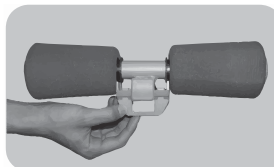

Assembly

3

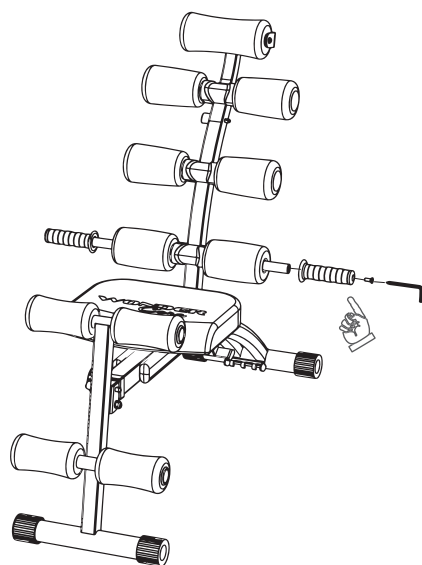

Assemble the handle

Assemble the handle as in the left drawing.

Using hex wrench to tighten the screw as in the below drawing.

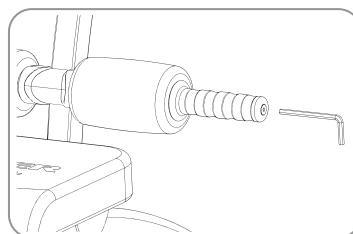

4

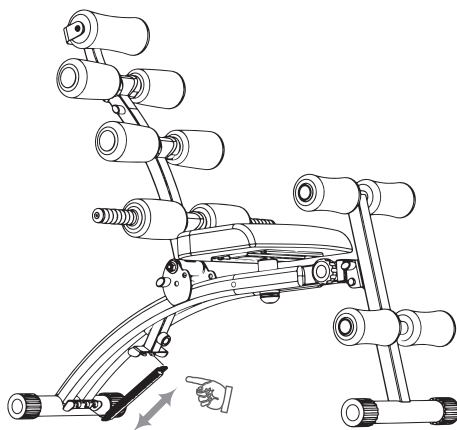

Assemble the springs

Assemble the spring as in the left drawing.

Tip. You can change the resistance by adding or removing the springs.

⚠ Whenever you are adding or removing the spring, always remember to fix the seat back

Start Use

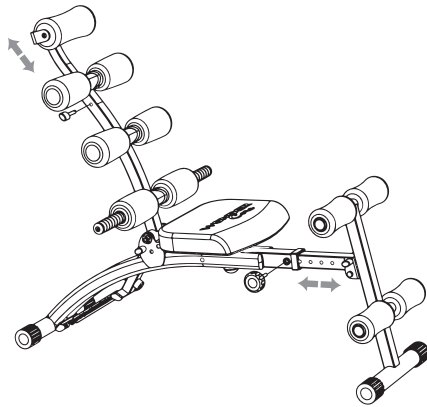

Adjust dimensions

- 1) Adjust the length
- 2) Adjust the head support

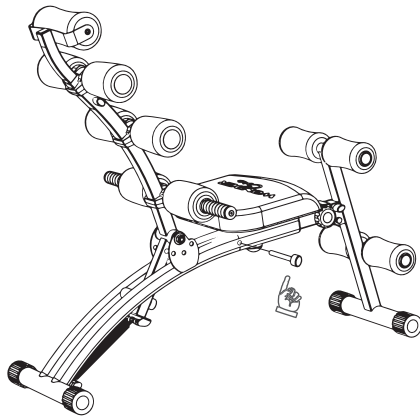

Sit up training

Remove the long pin and store it under the seat. See left drawing.

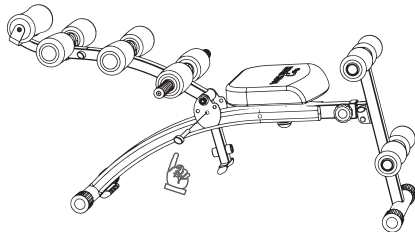

Swing motion training

Remove all the springs.
Turn seat back down to match the middle hole.
Insert long pin to fix the seat back.

How To Use

Start position:

Remove the pin underneath the bottom roller so the backrest will move freely towards the floor.

Seated position = determined by height - adjust machine to sit comfortably with feet securely locked into position - so no wasted energy in hip flexors.

Lay back onto the backrest / massage rollers. Head does not rest on the head rest. Abs are to be contracted at all times, so there is slight inwards curve to the spine.

Begin a regular crunch motion- lifting torso up and lowering back down, pushing against the back roller to engage the resistance.

1. AB EXERCISE:

a. CRUNCH

- Hands by side - easiest
- Hands across chest - Intermediate
- Hands on side of head - advanced

b. Shorter range of motion

- below 180 degrees. Head against head rest, hands by sides.

*After working Abs, you lock in a pin to lower the back rest, for the twister exercises *



How To Use

2. OBLIQUES / Lower Abs

Using the Twister seat - Hands on handles, body leaning back slightly.

- a. Bent knees = easier
 - Raise knees towards body, keep in position and twist side to side.
- b. Straight leg twist = advanced.
 - Straight legs - Raise off floor, keep in position and twist side to side.



3. LOWER ABS - seated Leg raises

- a. Legs out and crunch in to target lower abs

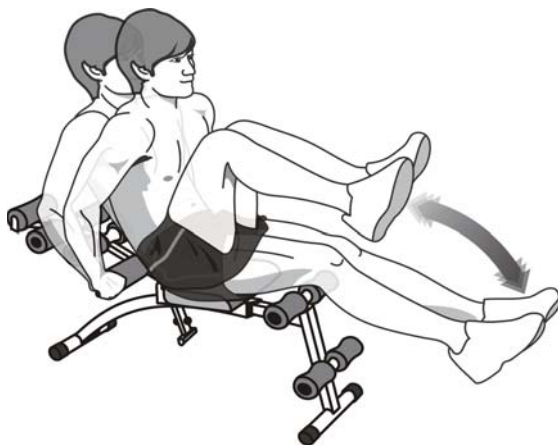

Storage & Maintenance

- ◆ Please avoid high temperature, dampness or direct sunlight. Keep it in a clean place with good ventilation.
- ◆ Fold it up when it is not in use and put it in a place out of reach of the children.

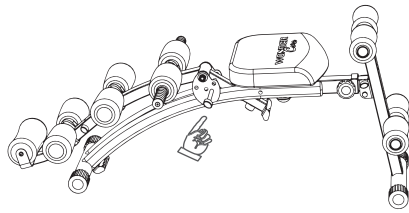

Fold seat back

Remove all the springs and put them in a place out of reach of the children. Take out long pin and fold seat back. Insert long pin into the hole as in the left drawing to fix it.

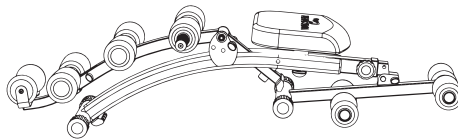

Fold leg

Remove the short pin and fold leg. Put back the short pin.

Maintenance

When the product is dirty, please dilute some neutral cleansing detergents and wet a cloth with it to clean. After that, wipe it dry with a dry cloth.

Alkaline cleaning agent or solvents like dilute solvents, volatile oil etc. may damage this product. Please do not use these.

Maintenance / Inspection

If the product is used after it has been lying idle for a period of time, please make sure that the product is fine and it can be used safely.

If the product gets wet carelessly, please use a dry cloth to wipe it dry to avoid making it slippery.

In the event of failure or abnormal occurrences, please contact the dealer.

If there is anything about the product that you do not understand, please contact the customer service center.

Waste Disposal

Due to the different recycling regulations between each country, please refer to these regulations before disposing this product.

WONDER[®] Core

Specs

Size	In Use / W92xD54xH85cm	Folded Up / W105xD54x32cm
Weight	About 11kg	
Material	Steel - ABS - PP - TPR - PA - Sponge	
Maximum Weight	120kg	
Country of origin	China	