

ATOTH-G Series

BLDC Motor Controller

User's Manual

Contents

Chapter One	Summary	1
Chapter Two	Main Features and Specifications	2
2.1	Basic Functions.....	2
2.2	Features.....	5
2.3	Specifications.....	6
Chapter Three	Installation Method	7
3.1	Install Controller.....	7
3.2	Line Connection.....	9
3.3	Communication Port.....	13
Chapter Four	Maintenance	15
4.1	Cleaning.....	15
4.2	Configuration.....	16
Table 1:	LED error code	17

Chapter One Summary

This manual describes the characteristics of ATOTH-G series e-bike controller products, the knowledge of installation method and maintenance. Before using the ATOTH-G brushless DC motor controller, please read this manual in detail, which will help you to install and use the controller correctly. If you have any problems with using, please contact us.

ATOTH-G series programmable controller is ATO company dedicated to an efficient, stable and easy to install the electric vehicle controller design, suitable for electric bicycles, electric motorcycles and electric scooter etc.. The series controller is able to output a high starting current and supply tight battery current limit. Therefore, it can work in a relatively small battery current conditions, and can provide a good acceleration and climbing ability.

ATOTH-G controller uses high power MOSFET high frequency design, the efficiency is up to 99%. Powerful intelligent microprocessor provides a comprehensive and accurate control for the ATOTH-G controller. The user can also connect the computer and the controller through the connecting wires we provide, to configure the controller, to guide the test and to obtain the diagnostic information simply and quickly.

Chapter Two Main Features and Specifications

2.1 Basic Functions

- (1) Fault detection and protection. It can identify faults via LED twinkling code.
- (2) Battery voltage real-time monitoring. It will stop work when battery voltage is higher or lower.
- (3) Built in current detection and over current protection.
- (4) The controller is equipped with temperature measurement and protection functions. At low and high temperatures, the current is cut to protect the controller and the battery. If the controller temperature is higher than 90 °C, the current will be a sharp decline. It will automatically cut off the output when it is up to 100 °C. At low temperatures, the current typically begins to drop at 0 °C.
- (5) At power-up, the voltage is constantly monitored by the controller. If it is found that the voltage is too high, the controller will immediately cut the current until the power generation stops.
- (6) The maximum speed can be configured half the maximum forward speed.
- (7) 5V sensor power supply.
- (8) 3 switch inputs. Connect to GND for valid signal. The default is the pedal safety switch input (to be configured via the customer software), the brake switch input and the reversing switch input.
- (9) Three 0-5V analog inputs. The default is the pedal analog signal input, the brake analog signal input and the motor temperature sensor analog signal input.

- (10) The Boost switch can be configured. The controller will output the maximum current, when the switch is turned on.
- (11) The Economy switch can be configured. Limiting the maximum drive current to the controller is half the normal case, when the switch is turned on.
- (12) The maximum current that can be configured half the maximum forward current.
- (13) Enhanced power generation brake function. The original ABS brake technology, so that your brakes are more powerful and smooth.
- (14) 12V brake signal input can be configured.
- (15) Motor over-temperature detection and protection (need to use our designated semiconductor temperature sensor KTY84-130).
- (16) 3-phase Hall position sensor input, open collector output and the controller provides pull-up resistor.
- (17) Controller power supply range is 8-30V optional.

2.2 Features

- (1) Designed for electric motorcycles and electric scooters.
- (2) Powerful and intelligent microprocessor.
- (3) High-speed low-loss synchronous rectification PWM modulation.
- (4) Strict current limit and torque control.
- (5) Limit the battery current function will not trigger the battery current limit protection and extend battery life.
- (6) Greater starting current can get a faster start-up speed.
- (7) Anti-electromagnetic interference and anti-vibration performance.
- (8) Fault indicator indicates a variety of failures for user-friendly testing and maintenance.
- (9) With electronic switching function.
- (10) It has a battery protection function: When the battery voltage is low, the alarm will be timely and the current attenuation, low output to stop the protection of the battery.
- (11) Beautiful and fast heat dissipation of aluminum with a heat spur shell.
- (12) With over-temperature protection: when the temperature is too high or too low will automatically current attenuation to protect the controller and battery.

- (13) Compatible with 60 degrees or 120 degrees Hall position sensor.
- (14) Support any poles of brushless motor.
- (15) Up to 40000 electric RPM. (electric RPM = mechanical speed * motor pole pairs).
- (16) The brake switch is used to control the regenerative braking.
- (17) 0-5V brake signal is used to control regenerative braking.
- (18) High pedal protection: The pedal signal is detected when the key is turned on, and is not output if a valid signal is present.
- (19) Three power generation modes: brake switch power generation, release pedal power generation and 0-5V analog signal power generation.
- (20) Current multiplication: Small battery current can get larger motor output current.
- (21) Easy to install: use a 3-wire pedal potentiometer to work.

2.3 Specifications

- (1) Working frequency: 16.6KHz
- (2) Standby current: Less than 0.5A
- (3) 5V sensor supply current: 40mA
- (4) Supply voltage: 72V and 18V~72V
- (5) Supply current: 150mA
- (6) Working voltage: 18V to 1.25* nominal value
- (7) Standard throttle input: 0-5V (Three wire resistance type), 1-4V (HALL type)
- (8) Brake analog signal and throttle signal input: 0-5V. Using three wire resistance type pedal to produce 0-5V signal
- (9) Full power operating temperature range: 0°C~50°C (Controller shell temperature)
- (10) Working temperature range: -30°C-90°C, 100 °C shutdown (Controller shell temperature)
- (11) Peak phase current, 10s: 50-120A (According to the model)
- (12) Continuous phase current: 5-50A (According to the model)
- (13) Maximum battery current: adjustable (Note: The default maximum current is set to 70%)
- (14) The input current of the controller shall be 1.5 times the rated current of the motor.

Chapter Three Installation Method

3.1 Install Controller

The installation position of the controller can be arbitrary, but the controller should be kept clean and dry. If you can't find a clean installation position, you should add a cover to prevent it from water and other contaminants.

In order to ensure full power output, the controller should use the four screws in a clean and flat metal surface, the controller and bottom plate fixed in close contact with sufficient cooling thermal grease filling suggestions. Shell outline and mounting holes are shown in Figure 1:

Attention:

Out of control: In some cases, the vehicle may be out of control, so the vehicle should be set up before the operation of the electric vehicle control circuit.

High current attention: Electric vehicle batteries can provide a very high current, in the installation of electric vehicles before the control circuit must be disconnected from the battery circuit. With insulation tools to prevent the occurrence of short circuit.

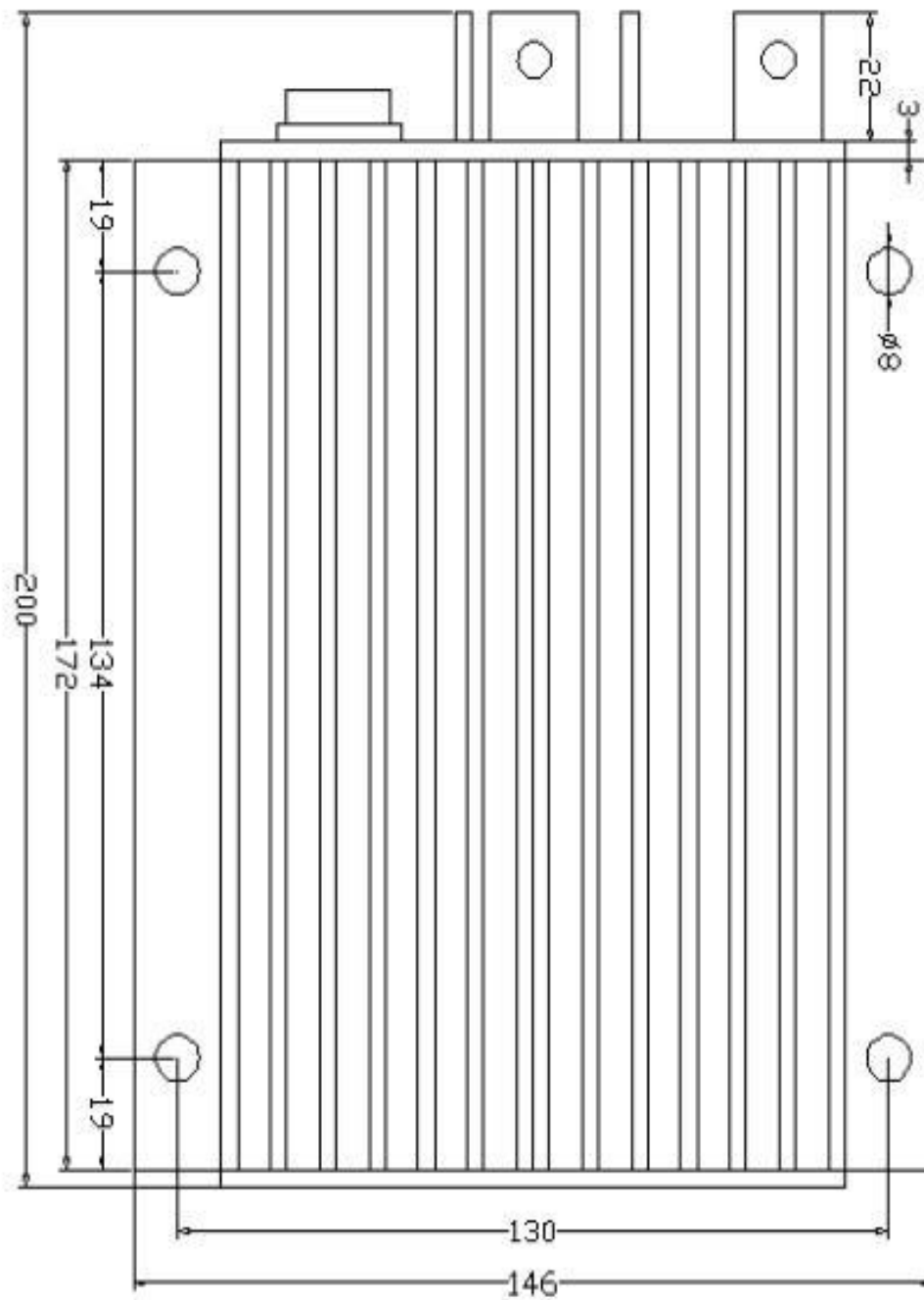

Height: 62mm

Figure 1: ATOTH-G mounting hole size (Unit: mm)

3.2 Line Connection

Five metal strips and a rugged connector (J2) provide the connection environment for battery, motor and controller signals. As shown in Feature 2:

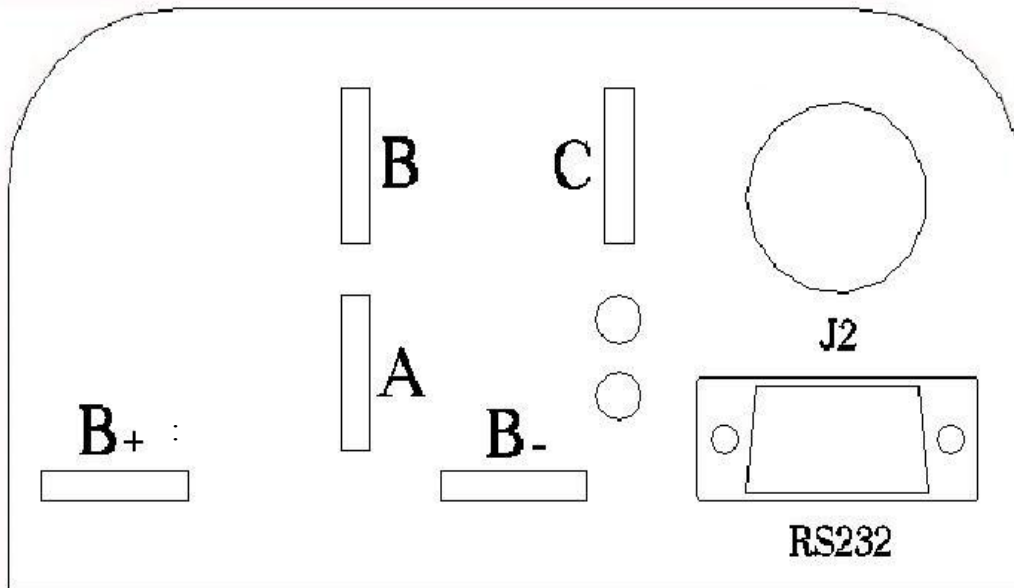

Figure 2: Brushless motor controller front panel

B⁺: Battery positive

B⁻: Battery negative

A: Output U/1/A phase, connect motor with thick yellow line

B: Output V/2/B phase, connect motor with thick green line

C: Output W/3/C phase, connect motor with thick blue line

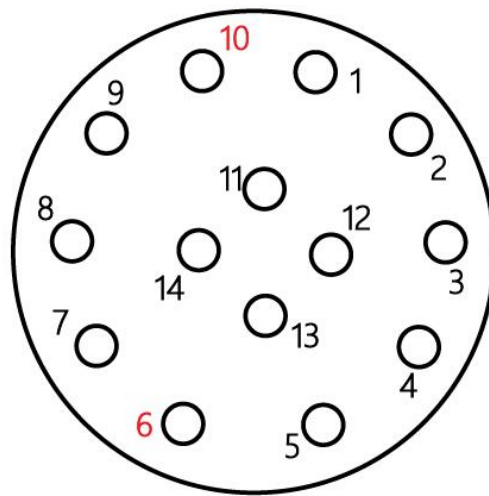

Figure 3: J2 pin position

J2 Pin definition: Circular connector M19-14

Notes:

1. PWR: Controller power supply (input)
2. RTN: Signal return, or power supply return
3. RTN: Signal return
4. 12V high-level brake and motor temperature input
5. Throttle analog input, 0-5V
6. Brake analog input, 0-5V / **CAN+**
7. 5V: 5V supply output, <40mA
8. Throttle switch input
9. Reversing switch input
10. Brake switch input / **CAN-**
11. Hall phase C

- 12. Hall phase B
- 13. Hall phase A
- 14. RTN: Signal return

Note:

- 1. All RTN and GND pins are internally connected, but isolated from B-.
- 2. Switch to ground is active. Open switch is inactive.

Caution: Make sure all connections are correct before apply power. Otherwise it may damage the controller! Please securely wire B- before applying power. It's preferred to place contactor or breaker on B+. Please place pre-charge resistor on any breaker! It can cause damage without it!!!

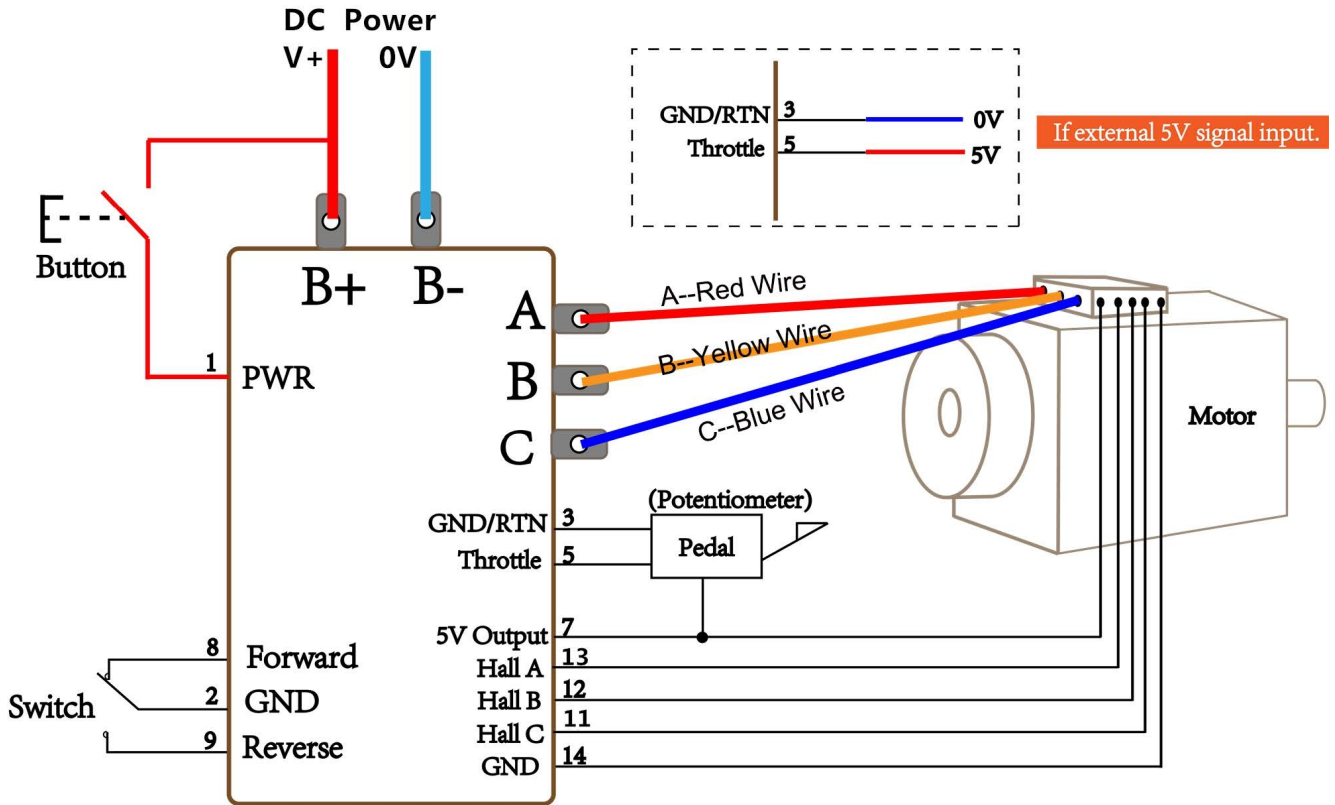
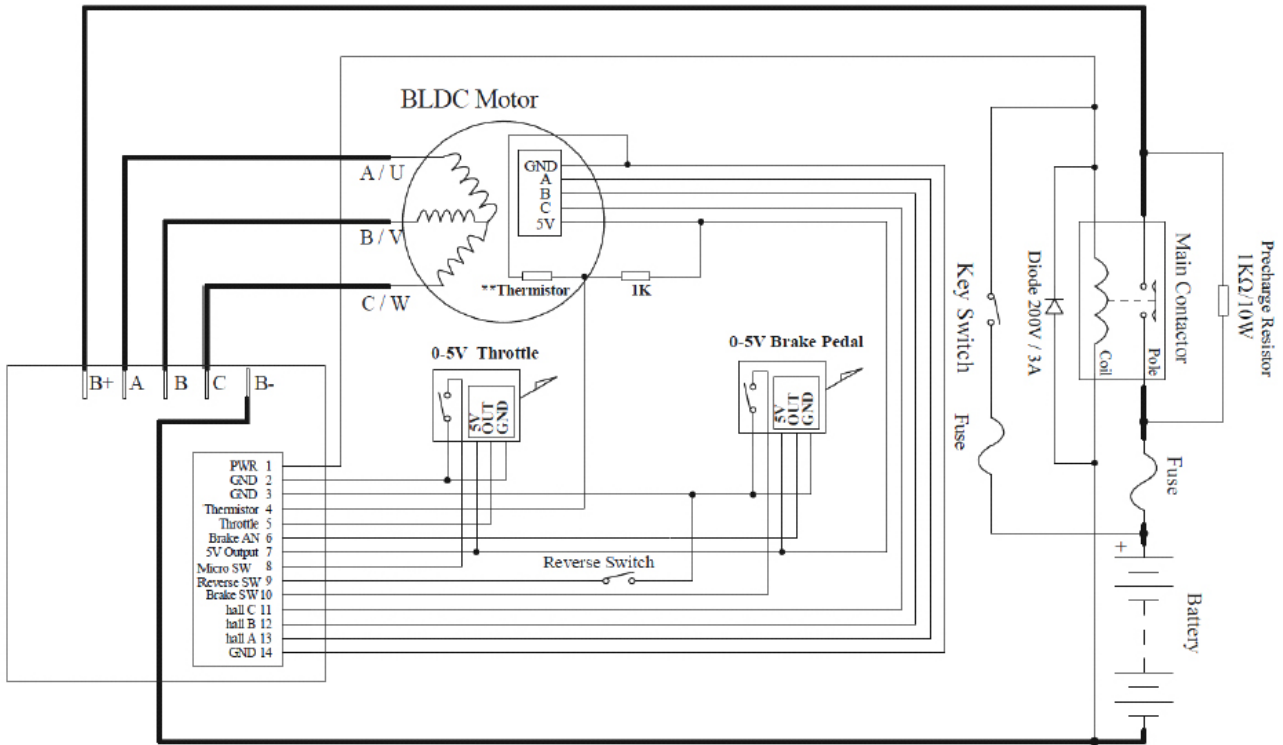

Figure 4: TH-G controller standard wiring



NOTE: Potentiometer can be used to output 0-5V.
 Please securely wire B- before any other wiring. Never put contactor or break on B-.
 ** Thermistor is optional item. default to KTY84-130.

Figure 5: TH-G controller battery wiring diagram (with pedal brake analog input)

3.3 Communication Port

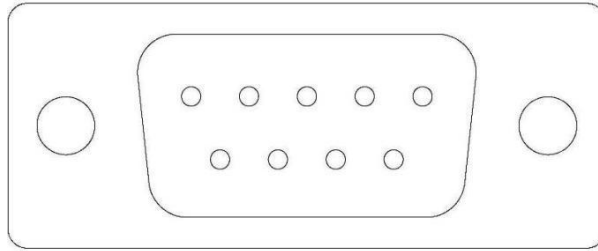

Figure 5: RS232 Interface

A RS232 port is provided to communicate with host computer for calibration and configuration.

3.4 Installation Check List

Before operating the vehicle, complete the following checkout procedures.

Use LED code as a reference as listed in Table 1.

Caution:

- **Put the vehicle up on blocks to get the drive wheels off the ground before beginning these tests.**
- **Do not allow anyone to stand directly in front of or behind the vehicle during the checkout.**
- **Make sure the PWR switch and the brake is off.**
- **Use well-insulated tools.**

1. Make sure the wire is connected correctly.
2. Turn the PWR switch on. The Green LED stay on steadily and Red LED turns off when the controller operates normally. If this does not happen, check continuity of the PWR and return.
3. The fault code will be detected automatically at restart.
4. With the brake switch open, select a direction and operate the throttle. The motor should spin in the selected direction. Verify wiring or voltage and the fuse if it does not. The motor should run faster with increasing throttle. If not, refer to the Table 1 LED code, and correct the fault as determined by the fault code.
5. Take the vehicle off the blocks and drive it in a clear area. It should have smooth acceleration and good power.

Chapter 4 Maintenance

There are no user-serviceable parts inside the controllers. Do not attempt to open the controller. Or will void warranty. However, cleaning the controller exterior periodically should be necessary.

The controller is inherently a high power device. When working with any battery powered vehicle, proper safety precautions should be taken. These include, but are not limited to, proper training, wearing eye protection, avoiding loose clothing and jewelry, and using insulated tools.

4.1 Cleaning

Although the controller requires virtually no maintenance after properly installation, the following minor maintenance is recommended in certain applications.

- Remove power by disconnecting the battery, starting with battery positive.
- Discharge the capacitors in the controller by connecting a load (such as a contactor coil, resistor or a horn) across the controller's B+ and B-terminals.
- Remove any dirt or corrosion from the bus bar area. The controller should be wiped with a moist rag. Be sure it is dry before reconnecting the battery.
- Make sure the connections to the bus bars are tight. Use two wrenches for this task in order to avoid stressing the bus bars; the wrenches should be well insulated.

4.2 Configuration

1. The parameters of the motor have been set before leaving the factory, and you don't need to reset them if there is no special requirement.
2. You can configure the controller with a host computer through either an RS232 or USB port.
3. The motor and the controller should be wired correctly. When configuring the software, the motor must stop running, otherwise the motor parameters may be lost and damaged.
4. Do not connect B+, throttle and so on. The controller may display fault code in some conditions, but it doesn't affect programming or configuration.
5. Use straight through RS232 cable or USB converter provided by ATO to connect to a host computer. Provide $> +18V$ to PW (for a 24V controller, provide $> +8V$). Wire power supply return (supply negative) to any RTN pin.
6. The software of the controller can run on win 7 or win 10 system. Generally, if there is no special requirement, ATO does not provide software.

Table 1: LED CODES

Green LED Codes

LED Code	Explanation	Solution
Green Off	No power or switched off	1. Check if all wires are correct. 2. Check fuse and power supply.
Green On	Normal operation	That"s great! You got solution!
Green & Red are both On		1. Software still upgrading. 2. Supply voltage too low or battery too high 3. The controller is damaged. Contact Wheatstone about a warranty repair.

Red LED Codes

LED Code	Explanation	Solution
1,2 □ □□	Over voltage error	1. Battery voltage is too high for the controller. Check battery volts and configuration. 2. Regeneration over-voltage. Controller will have cut back or stopped generation. 3. This only accurate to $\pm 2\%$ upon over voltage setting.
1,3 □ □□□	Low voltage error	1. The controller will clear after 5 seconds if battery volts returns to normal. 2. Check battery volts & recharge if required.
1,4 □ □□□□	Over temperature warning	1. Controller case temperature is above 90°C . Current will be limited. Reduce controller loading or switch Off until controller cools down. 2. Clean or improve heat sink or fan.
2,1 □□ □	Motor did not start	Motor did not reach 25 electrical RPM within 2 seconds of start-up. Hall sensor or phase wiring problem.

2,2	xx xx	Internal volts fault	<p>1. Measure that B+ & PWR are correct when measured to B- or RTN.</p> <p>2. There may be excessive load on the +5V supply caused by too low a value of regen or throttle potentiometers or incorrect wiring.</p> <p>3. Controller is damaged. Contact ATO about a warranty repair.</p>
2,3	xx xxx	Over temperature	The controller temperature has exceeded 100°C. The controller will be stopped but will restart when temperature falls below 80°C.
2,4	xx xxxx	Throttle error at power-up	Throttle signal is higher than the preset "dead zone" at Power On. Fault clears when throttle is released.
3,1	xxx x	Frequent reset	May be caused by over-voltage, bad motor intermittent earthing problem, bad wiring, etc.
3,2	xxx xx	Internal reset	May be caused by some transient fault condition like a temporary over-current, momentarily high or low battery voltage. This can happen during normal operation.
3,3	xxx xxx	Hall throttle is open or short-circuit	When the throttle is repaired, a restart will clear the fault
3,4	xxx xxxx	Non-zero throttle on direction change	Controller won't allow a direction change unless the throttle or speed is at zero. Fault clears when throttle is released.
4,1	xxxx x	Regen or Start-up over-voltage	Motor drive is disabled if an over-voltage is detected at start-up or during regen. The voltage threshold detection level is set during configuration.

4,2	□□□□ □□	Hall sensor error	<p>1. Incorrect or loose wiring or a damaged hall sensor.</p> <p>2. Also be caused by incorrect hall angle configuration (60 degree or 120 degree).</p>
4,3	□□□□ □□□□	Motor over-temperature	<p>Motor temperature has exceeded the configured maximum. The controller will shut down until the motor temperature cools down.</p>
4,4	□□□□ □□□□	Motor locked rotor	<p>When in locked rotor condition, the max output phase current of the motor will be limited to 90% of previous current. Once this problem disappears, the fault will clear and the max output phase current will return to normal.</p>
<p>The Red LED flashes once at power on as a confidence check and then normally stays Off. “1, 2” means the Red flashes once and after a second pause, flashes twice. The pause time between multiple flash code groups is two seconds.</p>			

CAN2.0-B Protocol for ATOTH-G

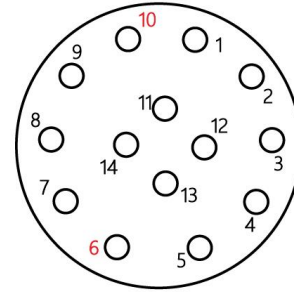

J2 Pin definition

6: CAN+ Green
10: CAN- White

Mnemo	Name/comments	Repeation rate	Data length	Identitier(HEX)	Byte	Bit	Data content	Value	Motoroln
Pump motor CMD		100ms	8	1801E5D0					
		PGN-							
P	R	DP	PF	PS	SA				
6	0	0	1	229	208				
					1-0		The given speed	0 low byte, 1 high byte Resolution: 1RPM/bit Range: 0~4000rpm	
					2		Acceleration setting	Resolution: 20RPM/bit Offset: 0 Range: 0~150	
					3	1-0	Output enable	00: Disable 01: Enable 10: Keep 11: No action	
						3~2	Direction control	00: Forward 01: Reverse 10: Keep 11: No action	
						7~4	The standby		
					4		Keep		
					5		Keep		
					6		Keep		
					7		Keep		
Pump motor Info1		100ms	8	1801D0E5					
		PGN-							
P	R	DP	PF	PS	SA				
6	0	0	1	208	229				
					0		Bus voltage	Resolution: 1V/bit Offset: 0 Range: 0~255V	
					1		Motor current	Resolution: 1A/bit Offset: 0 Range: 0~255A	
					2	1-0	Working status	00: Stand by 01: Star-up 10: Fault 11: Keep	
						3-2	Forward/Reverse rotation	00: Forward 01: Reverse 10: keep 11: Keep	
						7-4	Keep		
					3		Motor temperature	Resolution: 1°C/bit Offset: -40°C Range: -40~210°C	
					5-4		Actual motor speed	4 low byte, 5 high byte Resolution: 1RPM/bit Range: 0~4000rpm	
					6		Motor failure	1. Over voltage error 2. Low voltage error 3. Temperature warning of controller 4. Motor cannot be started 5. Internal voltage error 6. Over temperature error 7. Hall signal error 8. Motor temperature is too high 9. Motor stalling 10. Internal reset of controller 11. The controller is abnormal 12. When the controller is started, it is short circuited or open circuited	
						7	Controller temperature	Resolution: 1°C/bit Offset: -40°C Range: -40~210°C	
Note: the communication stops for 3 seconds and the motor stops output									