**Using the SPIRIT1 transceiver with range extender
under EN 300 220 at 868 MHz**

Placido De Vita

Introduction

The SPIRIT1 is a very low power RF transceiver, intended for RF wireless applications in the sub-1 GHz band. It is designed to operate both in the license-free ISM and SRD frequency bands at 169, 315, 433, 868 and 915 MHz.

This application note outlines the expected performance when using the SPIRIT1 under EN 300 220-1 (v2.4.1, 2012-01) [2] in the 869.400 to 869.650 MHz band. This band is not defined for specific applications, the maximum radiated power is +27 dBm (500 mW), and the defined channel spacing is < 25 kHz with 10% duty cycle. The whole stated frequency band may also be used as 1 wide-band channel for high speed data transmission.

For details on the regulatory limits in the 869.400 - 869.650 MHz SRD frequency bands, please refer to ETSI EN 300 220-1 v2.4.1 [2] and ERC Recommendation 70-03 [3]. These can be downloaded from www.etsi.org and www.ero.dk.

Contents

- 1 Application circuit 3**

- 2 Transmitter parameters 7**
 - 2.1 Adjacent channel power 7
 - 2.2 Modulation bandwidth 8
 - 2.3 Unwanted emissions in the spurious domain 10

- 3 Receiver parameters 12**
 - 3.1 Receiver sensitivity 12
 - 3.2 Blocking 13
 - 3.3 Receiver spurious radiation 14

- 4 Measuring equipment 17**

- 5 Reference 18**

- 6 Revision history 19**

1 Application circuit

Figure 1 shows the SPIRIT1 with range extender application board photo. The application is made up of 2 boards: a daughterboard and a motherboard. The daughterboard holds the SPIRIT1 with the circuits necessary for its function. For correct operation, the daughterboard must be plugged into the motherboard (see *Figure 2*) by two header 5x2 connectors (J6 and J7).

The motherboard is equipped with an STM32L152VBT6 microcontroller to correctly program the transceiver. The microcontroller is programmed with firmware developed for the SPIRIT1 application. A graphical user interface (GUI) has been developed for programming of the SPIRIT1.

The daughterboard includes a 50 MHz crystal to provide the correct oscillator to the SPIRIT1.

The SPIRIT1 has an internal SMPS that drastically reduces power consumption, making the SPIRIT1 the best-in-class for the application on this bandwidth. The SMPS is fed from the battery (1.8 V to 3.6 V) and provides a programmable voltage (1.4 V typ) to the device. An SMA connector is provided to connect the board to the antenna or to instrumentation in order to verify correct functionality and confirm the ETSI standard required.

A few of passive devices (inductors and capacitors) are used as matching/filtering for the power amplifier (PA) and balun network for the receiver.

A SAW filter is recommended in the TX path to attenuate the spurious emissions above the carrier frequency, which would otherwise violate spurious emissions limits under ETSI 300 220 [2]. The same SAW filter is provided in the RX path because, due the proximity of the GSM band, the receiver can be saturated in an application environment. This SAW filter can be bypassed using a short R1 resistor.

The SAW filter used is a Tai-Saw Technology CO., LTD. TA0801 868 MHz SAW filter [5].

An external FEM (front-end module) is used to improve the output power at the +27 dBm requested. The FEM utilized is a Skyworks SE2435L [6]. The device includes a power amplifier (PA) capable of about +27 dBm of transmitted output power. The receive channel consists of an integrated LNA (low noise amplifier) with programmable bypass. An integrated antenna switch, which provides an insertion loss of approximately 0.8 dB, separates the TX and RX paths.

Figure 1. SPIRIT1 with range extender application daughterboard

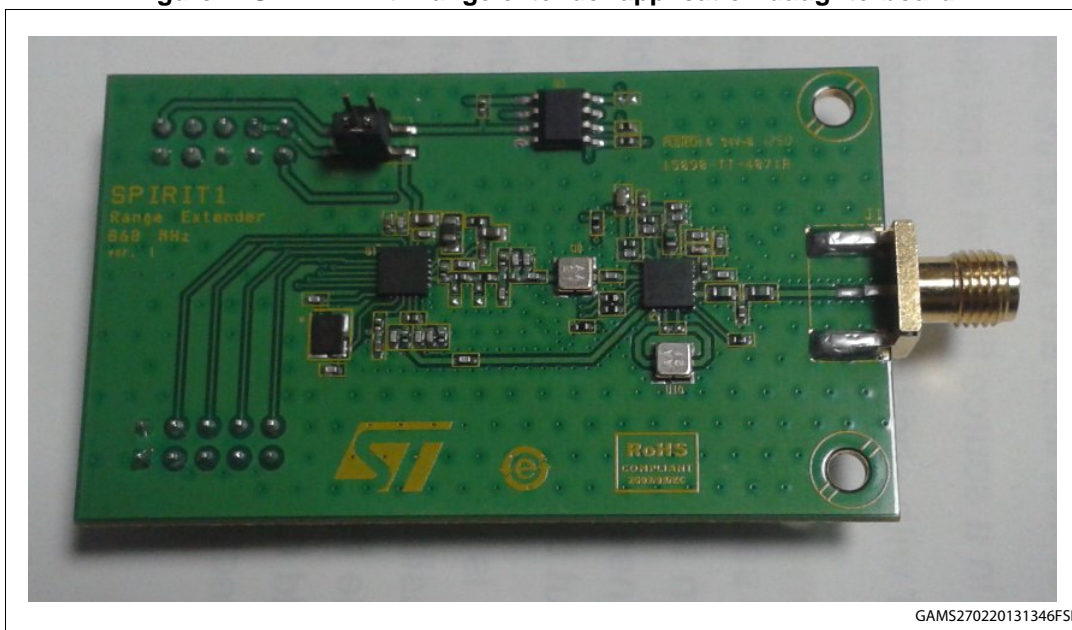

GAMS270220131346FSR

Figure 2. SPIRIT1 application daughterboard plugged into the motherboard

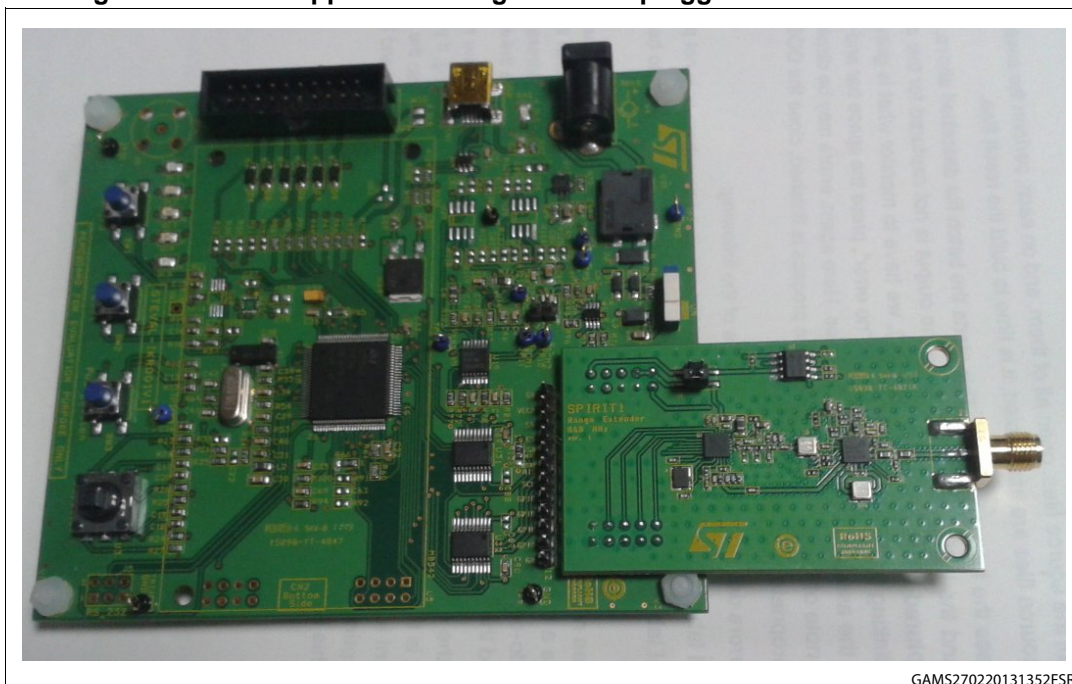

GAMS270220131352FSR

Figure 3. Daughterboard circuit schematic (1 of 2)

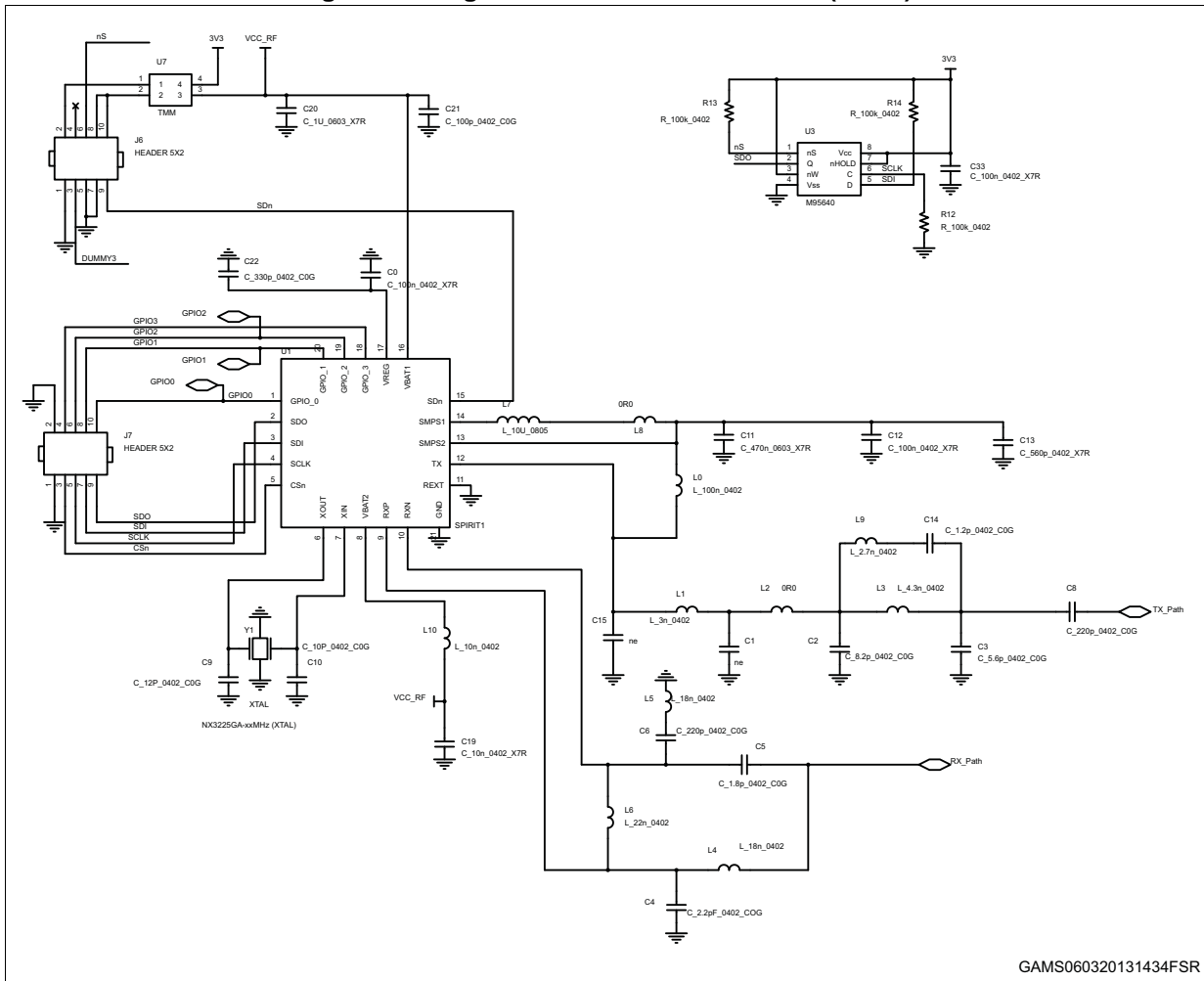

GAMS060320131434FSR

Figure 4. Daughterboard circuit schematic (2 of 2)

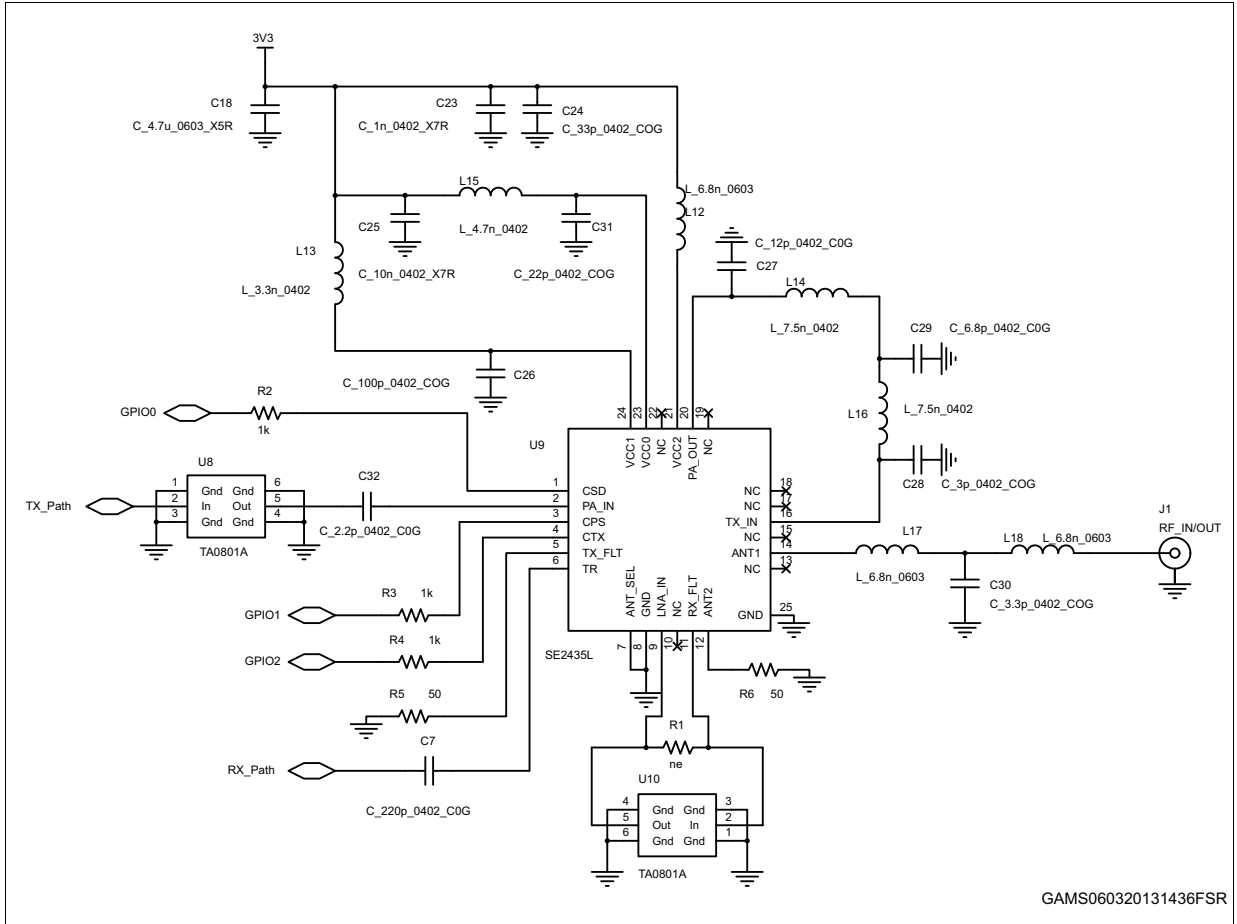

2 Transmitter parameters

All the measurements reported here have been measured with the following parameters: $T_C = 25\text{ }^\circ\text{C}$, $V_{DD} = 3.3\text{ V}$, $f = 869.500\text{ MHz}$.

The adjacent channel power, modulation bandwidth and unwanted emissions in the spurious domain measurements are also reported. The measurements are performed in accordance with EN 300 220 v1 [2].

2.1 Adjacent channel power

The adjacent channel power (ACP) is defined as the amount of the modulated RF signal power which falls within a given adjacent channel. This power is the sum of the mean power produced by the modulation, hum and noise of the transmitter. This measurement is applicable only to narrow band systems.

This test measures the power transmitted on the adjacent channel during continuous modulation. The ACP is measured with a spectrum analyzer conforming to the requirements given in the EN 300 220-1 v2.4.1 (2012-01) [2] annex C.

In this application note, the ACP measured with 12.5 kHz channel spacing is investigated. For this measurement, the integrated bandwidth of the adjacent channel is 8.5 kHz. The ETSI limits for the ACP is $10\text{ }\mu\text{W}$ (-20 dBm) for channel separation of 12.5 kHz.

Figure 5 illustrates the measured ACP at the 869.5 MHz center frequency. The data rate is set to 2.4 kbps, the frequency deviation is set to 2.4 kHz, and the modulation is set to Gaussian FSK (GFSK) with a BT = 0.5.

The output power integrated around the carrier is 27 dBm in 8.5 kHz bandwidth. With this power the ACP is -30 dBm, which is 10 dB better than the ETSI limit.

The SPIRIT1 is fully compliant with the ETSI transmitter adjacent channel power requirements, with margin.

Figure 5. adjacent power measurement, 12.5 kHz narrow band channel spacing

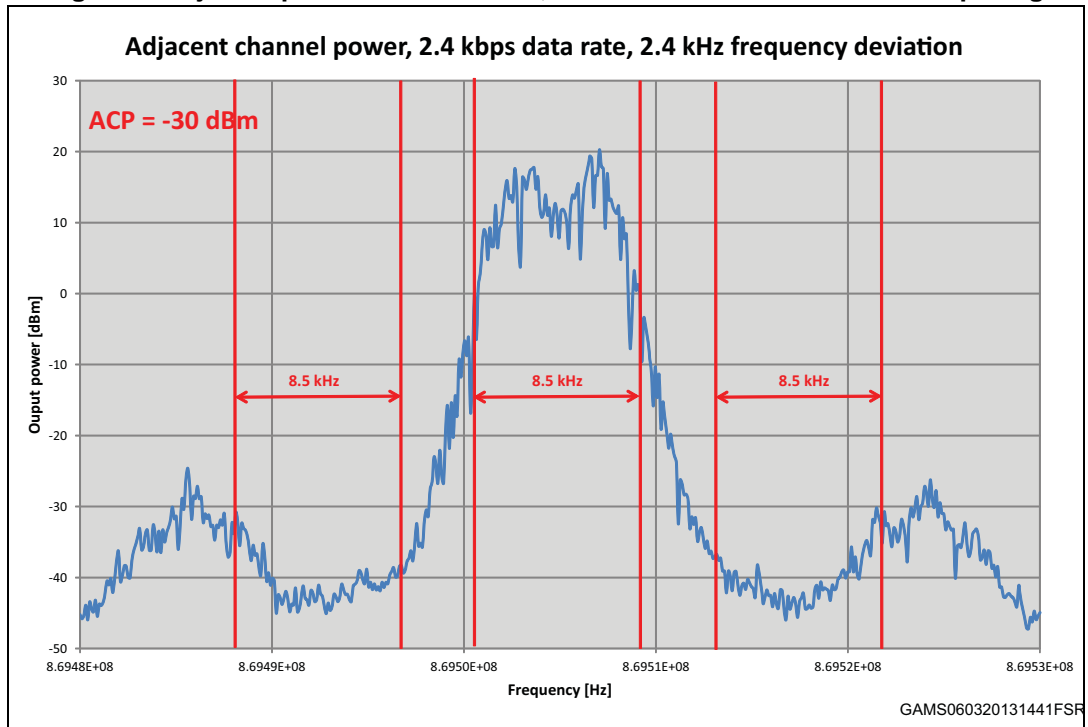

2.2 Modulation bandwidth

The range of the modulation bandwidth includes all associated side bands above the appropriate emissions level and the frequency error or drift under extreme test conditions. The frequency drift in extreme test conditions primarily depends on the crystal quality, which is not included in this report.

This measurement applies to equipment not covered by the adjacent channel power clause, so the measurement is performed for a case with a channel bandwidth greater than 25 kHz. [Figure 6](#) illustrates the ETSI spectral mask with which the radio must comply at the sub-band edges. Basically, there are only two limit thresholds. What changes is the bandwidth of integration at the different offset regions.

The same spectral mask is reported in [Figure 7](#). The device center frequency is 869.5 MHz, the data rate is set to 38.4 kbps, the frequency deviation to 20 kHz and Gaussian FSK (GFSK) with a BT = 0.5 as modulation is chosen. The applied output power is set to 27 dBm.

With these parameters, the spectral masks of the SPIRIT1 complies with ETSI [2] sub-clause 7.7.

Figure 6. ETSI spectral mask measurement limits and sub-band edges

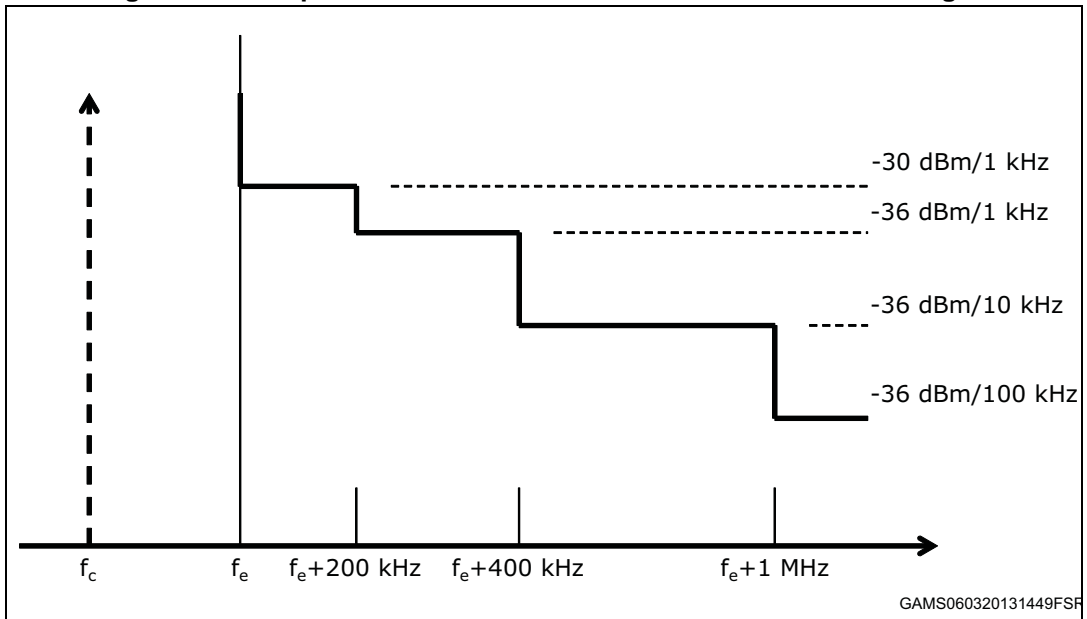

where:

- f_c is the emission center frequency
- f_e is the sub-band edge frequency
- only the upper half of the emission is shown. The lower half is a mirror image.

Figure 7. spectral mask measurement, 100 kHz channel spacing

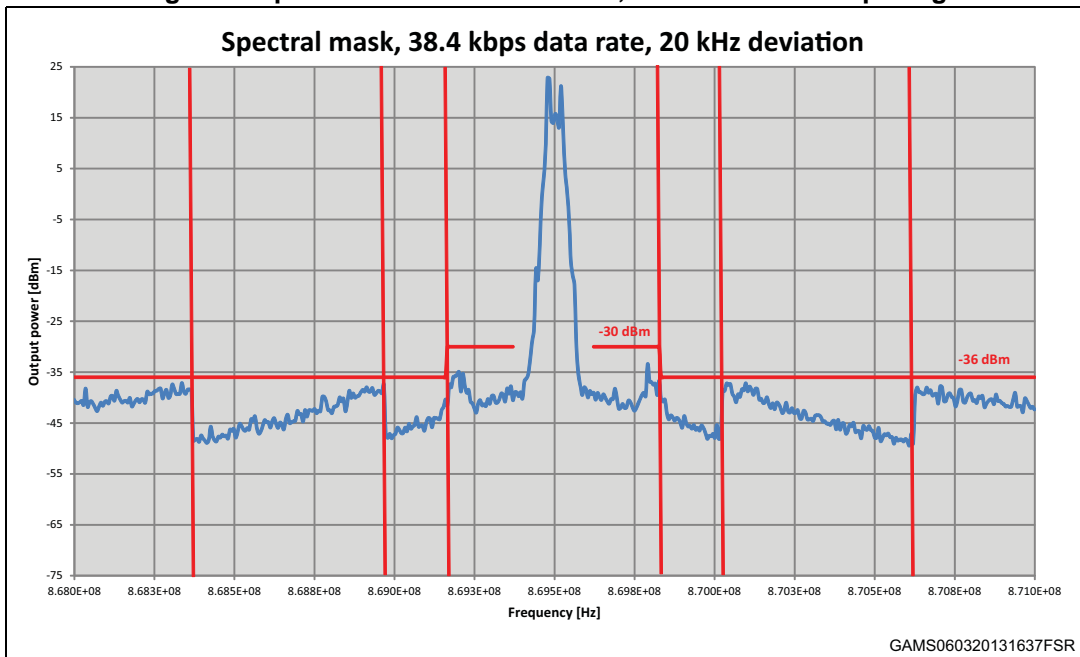

2.3 Unwanted emissions in the spurious domain

Spurious emissions are unwanted emissions in the spurious domain at frequencies other than those of the desired carrier frequency and its sidebands associated with normal test modulation.

A spectrum analyzer is used as external receiver. The measurement is performed setting the SPIRIT1 without modulation and observing it at up to 6 GHz as described in the ETSI [2] subclause 7.8.

The measurement is split into two graphs: in *Figure 8* the unwanted spurious emission for frequencies below 1 GHz is shown. The measurement is performed setting the instrument to a resolution bandwidth of 100 kHz, as required by ETSI [2]. In *Figure 9*, the unwanted spurious emission for frequencies from 1 GHz to 6 GHz is shown. The measurement is performed setting the instrument to a resolution bandwidth of 1 MHz, as required by ETSI [2]. In the two graphs, the mask requirement from ETSI is reported also.

The unwanted emissions in the spurious domain of the SPIRIT1 complies with ETSI [2] sub-clause 7.8.

Figure 8. Unwanted spurious emission below 1 GHz

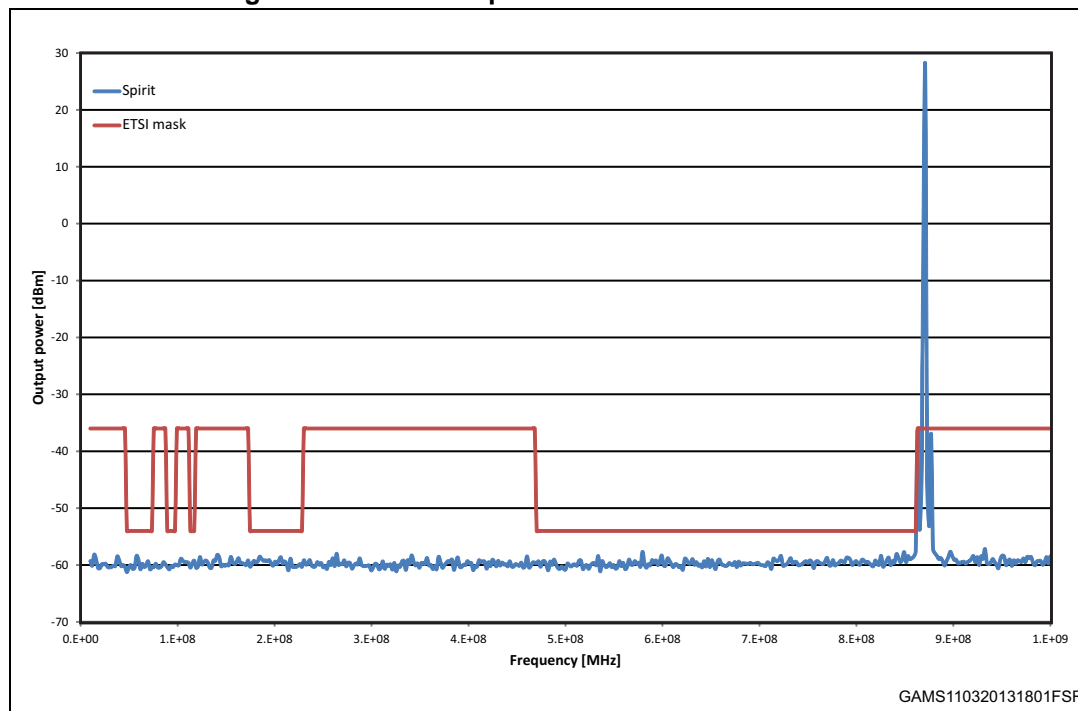
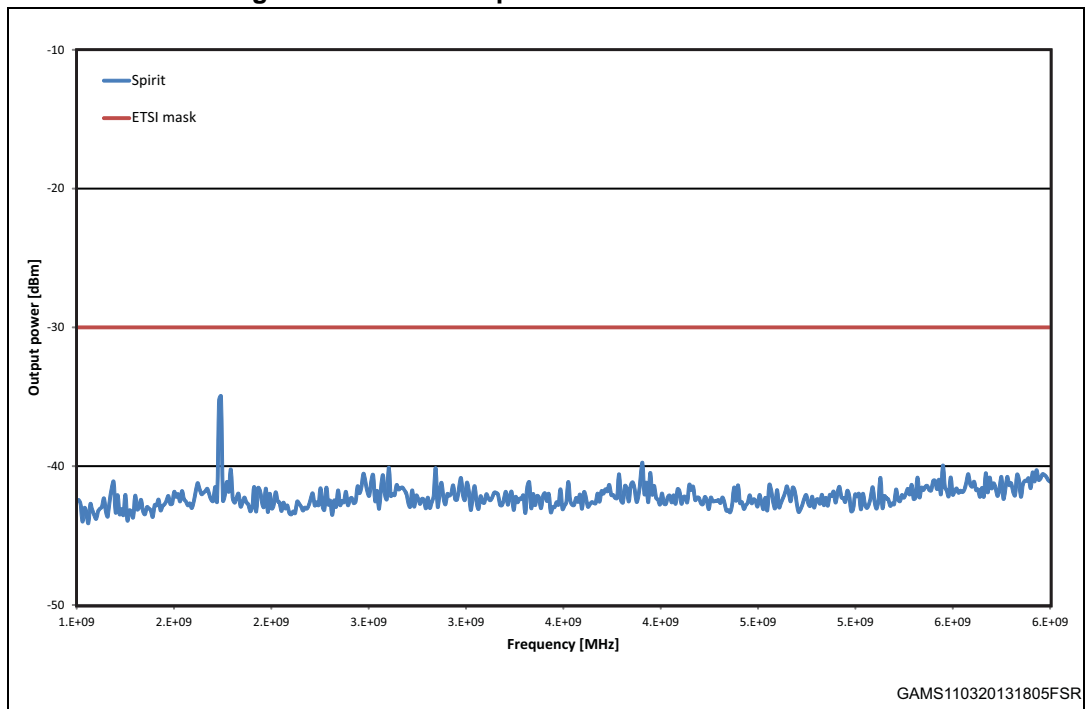

Figure 9. Unwanted spurious emission over 1 GHz



3 Receiver parameters

All the measurement reported here are measured with the following parameters: $T_C = 25\text{ }^\circ\text{C}$, $V_{DD} = 3.3\text{ V}$, $f = 869.500\text{ MHz}$.

The family of short range radio devices is divided into three receiver categories, each having a set of relevant receiver requirements and minimum performance criteria. The set of receiver requirements depends on the choice of receiver category by the equipment provider. The SPIRIT1 is a transceiver that meets the requirements of receiver category 2, which means medium reliable SRD communication media that can cause inconvenience to persons, which cannot simply be overcome by other means.

The main parameters that have to be measured for category 2 devices are sensitivity, blocking and receiver spurious radiation.

3.1 Receiver sensitivity

Receiver sensitivity is the minimum level of the signal at receiver input, produced by a carrier at the nominal frequency of the receiver, modulated with the normal test signal modulation, which produces performance of a bit error rate (BER) of 10⁻² without correction.

Under normal test conditions, the value of the typical usable sensitivity for 25 kHz channel spacing equipment with a 16 kHz bandwidth shall not exceed -107 dBm. If the RX bandwidth is not 16 kHz, the sensitivity limit is modified according to the following formula:

Equation 1

$$Sp[\text{dBm}] = 10\log\left(\frac{BW[\text{kHz}]}{16}\right) - 107$$

The measurement is performed using an RF signal source generator centered at the same receiver frequency as the desired modulation signal. The demodulated data and clock are taken from the SPIRIT1 receiver and sent to the same generator to do the BER measurement. The generator signal level is reduced until a BER of 1% is obtained.

To reduce power consumption, an internal SMPS is integrated in the SPIRIT1. [Figure 10](#) demonstrates the ETSI 1% BER sensitivity limit (red line) and the SPIRIT1 sensitivity for different data rate. This application note outlines the expected performance when using the SPIRIT1 under EN 300 220-1 (v2.4.1, 2012-01) [2] in the 869.400 - 869.650 MHz band, with the channel lower than 25 kHz, or with a single channel of the 250 kHz band. Just to show the real performance of the application, different channel spacings are shown. The test conditions are: GFSK (BT = 0.5) modulation with 2.4 kHz frequency deviation and 8 kHz channel bandwidth for the 2.4 kbps data rate, GFSK (BT = 0.5) modulation with 1.2 kHz frequency deviation and 8 kHz channel bandwidth for the 4.8 kbps data rate, GFSK (BT = 1) modulation with 20 kHz frequency deviation and 250 kHz channel bandwidth for the 38.4 kbps data rate. The sensitivity is also measured with a PER of 1%.

The SPIRIT1 is fully compliant with ETSI class 2 receiver sensitivity requirements, with a large margin.

Figure 10. Sensitivity vs. data rate with 1% BER

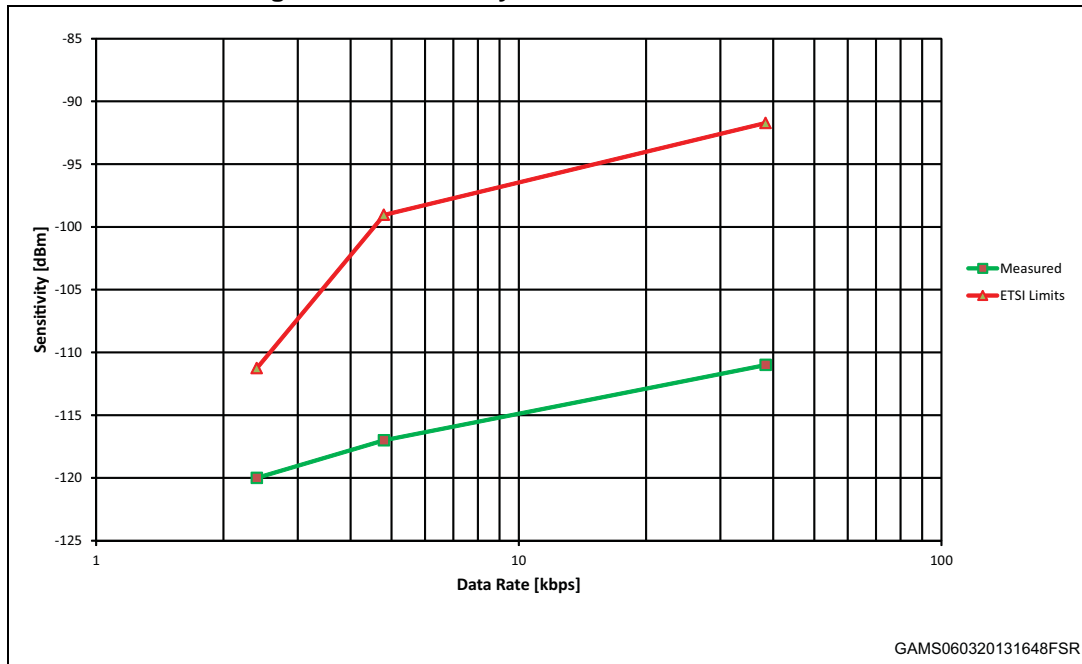

3.2 Blocking

Blocking is a measure of the capability of the receiver to receive a wanted modulated signal without exceeding a given degradation due to the presence of an unwanted input signal at any frequency other than those of the spurious responses or the adjacent channels or bands.

All the blocking results are measured by positioning the input power 3 dB above the measured sensitivity limit reported in the previous paragraph, with a primary signal source generator. A second generator with an un-modulated signal is used as the interferer and combined with the primary signal using a power combiner. The second interferer generator is placed at the desired frequency offset and the power is increased until the BER degradation of 1% is obtained.

ETSI specifies the blocking limits in absolute values at two points: ± 2 and ± 10 MHz. The limit for class 2 receiver at ± 2 MHz is $> 35 \text{ dB} - 10\log(\text{BWkHz}/16 \text{ kHz})$, at ± 10 MHz it is $> 60 \text{ dB} - 10\log(\text{BWkHz}/16 \text{ kHz})$. [Figure 11](#) shows the blocking curves with 2.4 kbps and 4.8 kbps data rates; [Figure 12](#) shows the blocking curve with 38.4 kbps data rate.

The SPIRIT1 with range extender is fully compliant with ETSI class 2 receiver blocking requirements, with a large margin.

Figure 11. RX blocking vs. CW interferer offset with 1% BER, 1.2 kbps data rate

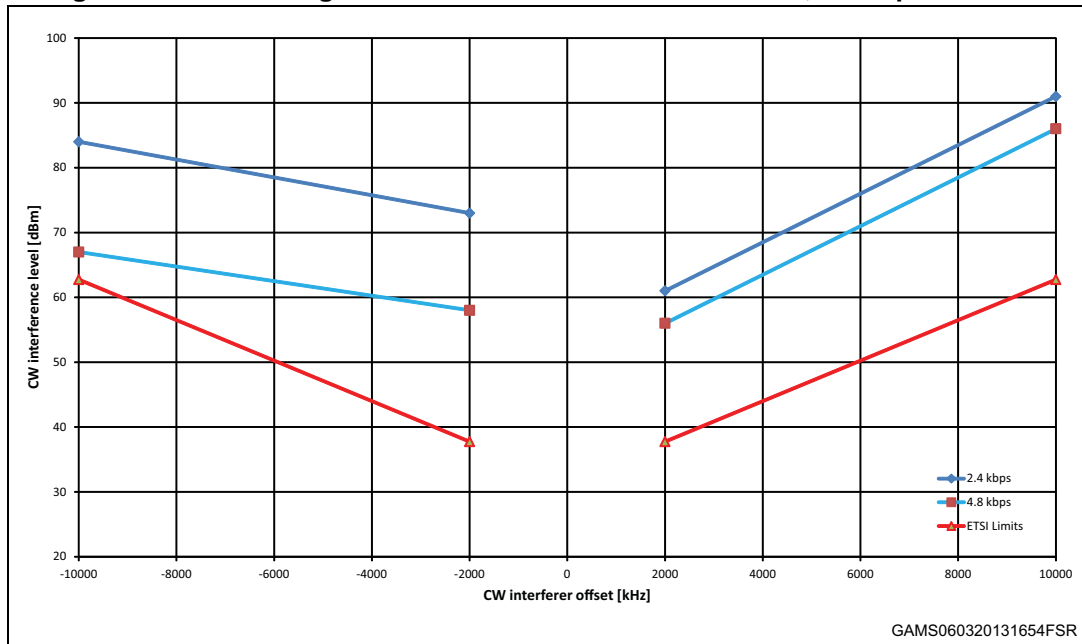
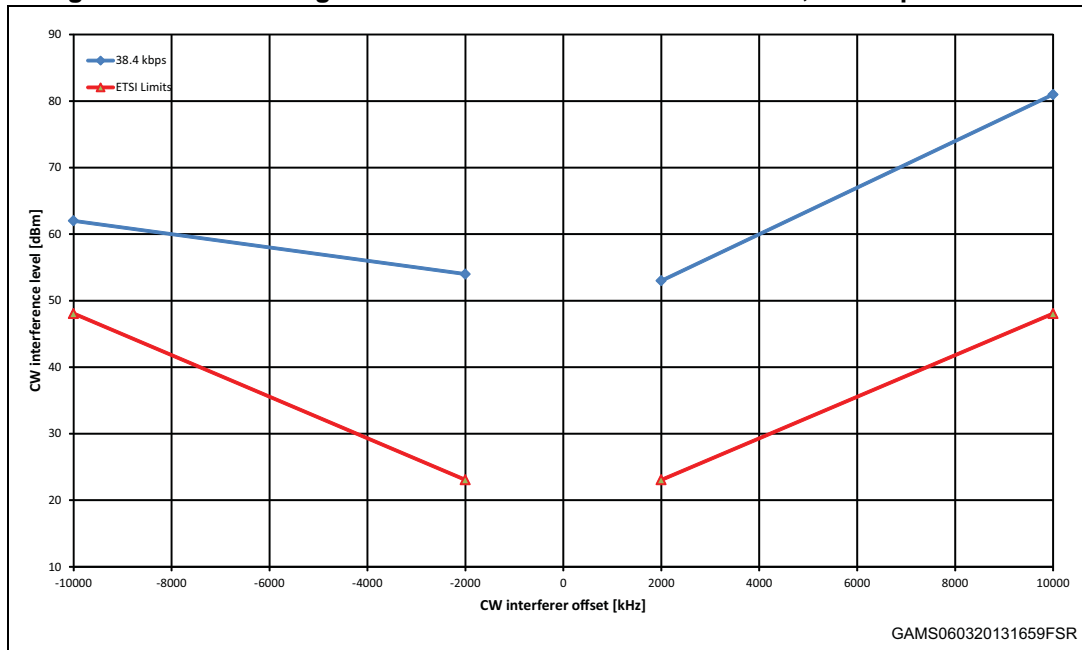

Figure 12. RX blocking vs. CW interferer offset with 1% BER, 500 kbps data rate



3.3 Receiver spurious radiation

Spurious radiation from the receiver are components at any frequency radiated by the equipment and antenna.

A spectrum analyzer is used as external receiver. The measurement is performed setting the SPIRIT1 without modulation and observing it at up to 6 GHz as described in the ETSI [2] sub-clause 8.6.

The measurement is split into two graphs: in *Figure 13* the unwanted spurious emission for frequencies below 1 GHz is shown. The measurement is performed setting the instrument to a resolution bandwidth of 100 kHz, as required by ETSI [2]. In *Figure 14* the spurious radiation from the receiver for frequencies from 1 GHz to 6 GHz is shown. The measurement is performed setting the instrument to a resolution bandwidth of 1 MHz, as required by ETSI [2]. In the two graphs, the mask required by ETSI is reported also.

The receiver spurious radiation of the SPIRIT1 complies with ETSI [2] sub-clause 8.6.

Figure 13. Receiver spurious emission below 1 GHz

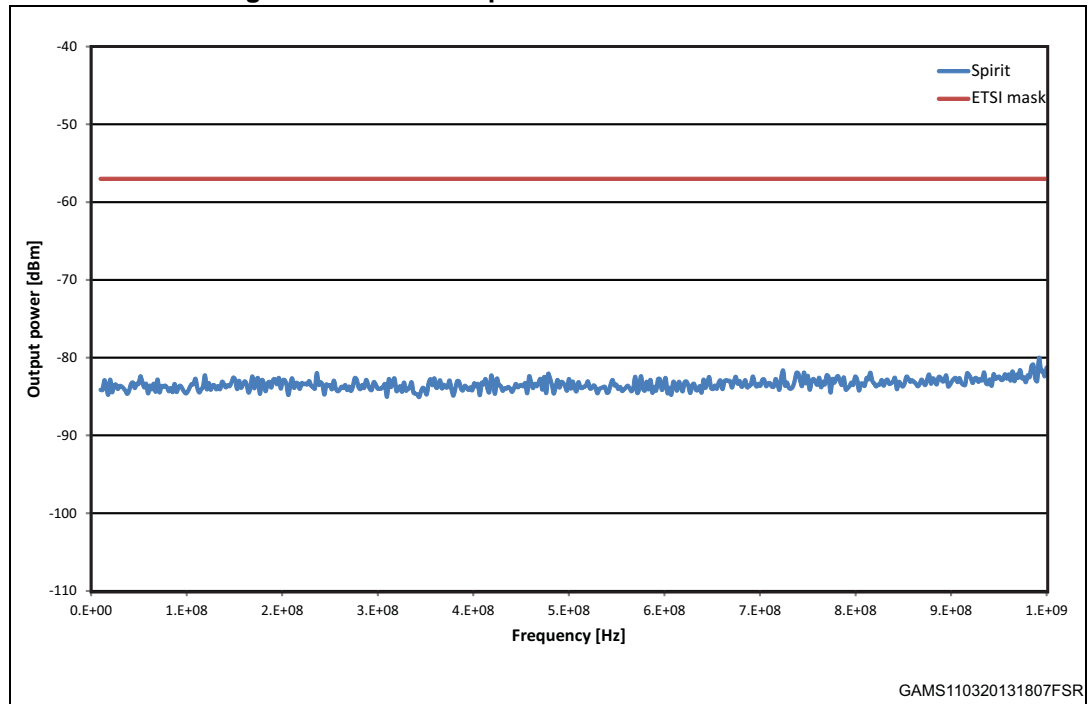
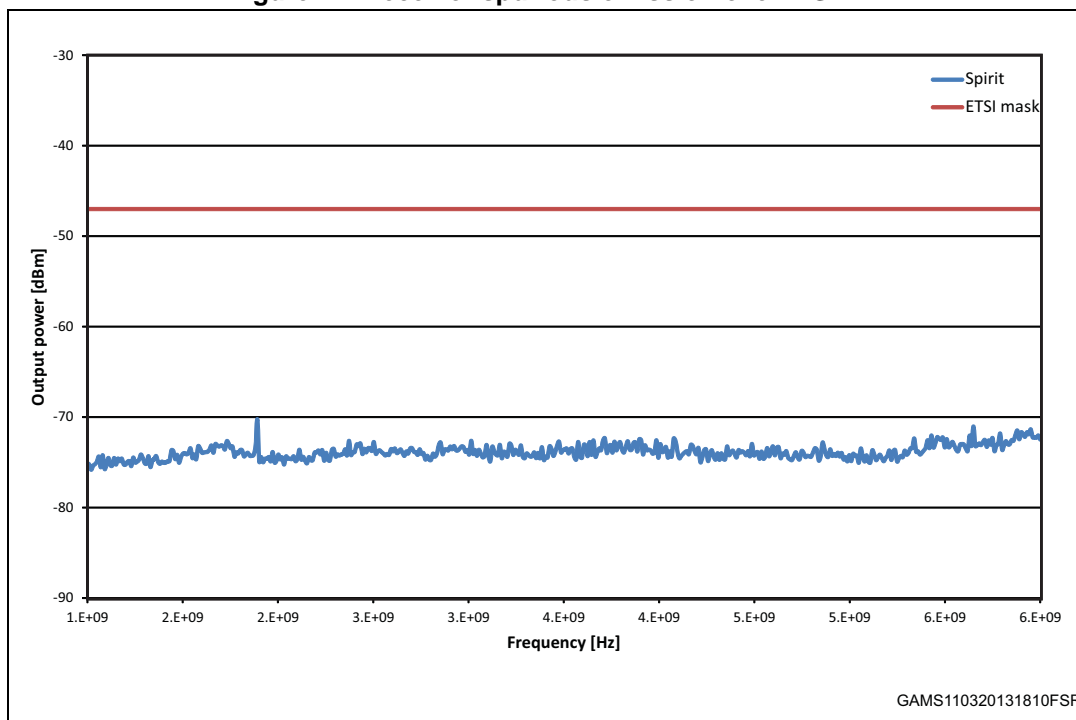

Figure 14. Receiver spurious emission over 1 GHz



4 Measuring equipment

The following equipment was used to perform the measurements.

Table 1. Measuring equipment

Measurement	Instrument type	Instrument model
RX	Signal generator	Agilent ESG E4438C Agilent ESG E4438C
TX	Signal analyzer	R&S FSIQ7

5 Reference

1. STMicroelectronics SPIRIT1 datasheet
2. ETSI EN300 220 V2.4.1: "Electromagnetic compatibility and Radio spectrum Matters (ERM); Short Range Devices (SRD); Radio equipment to be used in the 25 MHz to 1000 MHz frequency range with power levels ranging up to 500 mW"
3. CEPT/ERC/Recommendation 70-03: "Relating to the use of Short Range Devices (SRD)"
4. CEN/TC prEN 13757-4:2011.10: "Communication systems for meters and remote reading of meters - Part 4: Wireless meter readout (Radio meter reading for operating in SRD bands)"
5. TAI-SAW Technology CO., LTD. TA0801A "SAW Filter 868 MHz" datasheet
6. Skyworks "SE2435L: 960 - 930 MHz High Power RF Front End Module" datasheet

6 Revision history

Table 2. Document revision history

Date	Revision	Changes
24-Oct-2013	1	Initial release.

Please Read Carefully:

Information in this document is provided solely in connection with ST products. STMicroelectronics NV and its subsidiaries ("ST") reserve the right to make changes, corrections, modifications or improvements, to this document, and the products and services described herein at any time, without notice.

All ST products are sold pursuant to ST's terms and conditions of sale.

Purchasers are solely responsible for the choice, selection and use of the ST products and services described herein, and ST assumes no liability whatsoever relating to the choice, selection or use of the ST products and services described herein.

No license, express or implied, by estoppel or otherwise, to any intellectual property rights is granted under this document. If any part of this document refers to any third party products or services it shall not be deemed a license grant by ST for the use of such third party products or services, or any intellectual property contained therein or considered as a warranty covering the use in any manner whatsoever of such third party products or services or any intellectual property contained therein.

UNLESS OTHERWISE SET FORTH IN ST'S TERMS AND CONDITIONS OF SALE ST DISCLAIMS ANY EXPRESS OR IMPLIED WARRANTY WITH RESPECT TO THE USE AND/OR SALE OF ST PRODUCTS INCLUDING WITHOUT LIMITATION IMPLIED WARRANTIES OF MERCHANTABILITY, FITNESS FOR A PARTICULAR PURPOSE (AND THEIR EQUIVALENTS UNDER THE LAWS OF ANY JURISDICTION), OR INFRINGEMENT OF ANY PATENT, COPYRIGHT OR OTHER INTELLECTUAL PROPERTY RIGHT.

ST PRODUCTS ARE NOT DESIGNED OR AUTHORIZED FOR USE IN: (A) SAFETY CRITICAL APPLICATIONS SUCH AS LIFE SUPPORTING, ACTIVE IMPLANTED DEVICES OR SYSTEMS WITH PRODUCT FUNCTIONAL SAFETY REQUIREMENTS; (B) AERONAUTIC APPLICATIONS; (C) AUTOMOTIVE APPLICATIONS OR ENVIRONMENTS, AND/OR (D) AEROSPACE APPLICATIONS OR ENVIRONMENTS. WHERE ST PRODUCTS ARE NOT DESIGNED FOR SUCH USE, THE PURCHASER SHALL USE PRODUCTS AT PURCHASER'S SOLE RISK, EVEN IF ST HAS BEEN INFORMED IN WRITING OF SUCH USAGE, UNLESS A PRODUCT IS EXPRESSLY DESIGNATED BY ST AS BEING INTENDED FOR "AUTOMOTIVE, AUTOMOTIVE SAFETY OR MEDICAL" INDUSTRY DOMAINS ACCORDING TO ST PRODUCT DESIGN SPECIFICATIONS. PRODUCTS FORMALLY ESCC, QML OR JAN QUALIFIED ARE DEEMED SUITABLE FOR USE IN AEROSPACE BY THE CORRESPONDING GOVERNMENTAL AGENCY.

Resale of ST products with provisions different from the statements and/or technical features set forth in this document shall immediately void any warranty granted by ST for the ST product or service described herein and shall not create or extend in any manner whatsoever, any liability of ST.

ST and the ST logo are trademarks or registered trademarks of ST in various countries.

Information in this document supersedes and replaces all information previously supplied.

The ST logo is a registered trademark of STMicroelectronics. All other names are the property of their respective owners.

© 2013 STMicroelectronics - All rights reserved

STMicroelectronics group of companies

Australia - Belgium - Brazil - Canada - China - Czech Republic - Finland - France - Germany - Hong Kong - India - Israel - Italy - Japan - Malaysia - Malta - Morocco - Philippines - Singapore - Spain - Sweden - Switzerland - United Kingdom - United States of America

www.st.com