



# **Kawasaki** MULE 3010 TRANS 4 × 4



## **Utility Vehicle Service Manual**



# Quick Reference Guide

<b>General Information</b>	<b>1</b>
<b>Periodic Maintenance</b>	<b>2</b>
<b>Fuel System</b>	<b>3</b>
<b>Cooling System</b>	<b>4</b>
<b>Engine Top End</b>	<b>5</b>
<b>Converter System</b>	<b>6</b>
<b>Engine Lubrication System</b>	<b>7</b>
<b>Engine Removal/Installation</b>	<b>8</b>
<b>Engine Bottom End</b>	<b>9</b>
<b>Transmission</b>	<b>10</b>
<b>Wheels/Tires</b>	<b>11</b>
<b>Final Drive</b>	<b>12</b>
<b>Brakes</b>	<b>13</b>
<b>Suspension</b>	<b>14</b>
<b>Steering</b>	<b>15</b>
<b>Frame</b>	<b>16</b>
<b>Electrical System</b>	<b>17</b>
<b>Appendix</b>	<b>18</b>

This quick reference guide will assist you in locating a desired topic or procedure.

- Bend the pages back to match the black tab of the desired chapter number with the black tab on the edge at each table of contents page.
- Refer to the sectional table of contents for the exact pages to locate the specific topic required.



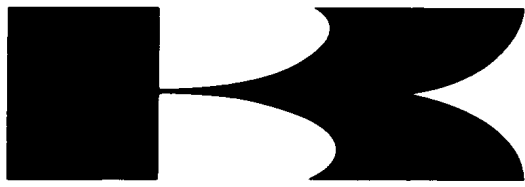

**Kawasaki**

**MULE 3010 TRANS 4 × 4**

# Utility Vehicle Service Manual

---

All rights reserved. No parts of this publication may be reproduced, stored in a retrieval system, or transmitted in any form or by any means, electronic mechanical photocopying, recording or otherwise, without the prior written permission of Quality Assurance Department/Consumer Products & Machinery Company/Kawasaki Heavy Industries, Ltd., Japan.

No liability can be accepted for any inaccuracies or omissions in this publication, although every possible care has been taken to make it as complete and accurate as possible.

The right is reserved to make changes at any time without prior notice and without incurring an obligation to make such changes to products manufactured previously. See your dealer for the latest information on product improvements incorporated after this publication.

All information contained in this publication is based on the latest product information available at the time of publication. Illustrations and photographs in this publication are intended for reference use only and may not depict actual model component parts.

Property of [www.SmallEngineDiscount.com](http://www.SmallEngineDiscount.com) - Not for Resale

## LIST OF ABBREVIATIONS

A	ampere(s)	lb	pounds(s)
ABDC	after bottom dead center	m	meter(s)
AC	alternating current	min	minute(s)
ATDC	after top dead center	N	newton(s)
BBDC	before bottom dead center	Pa	pascal(s)
BDC	bottom dead center	PS	horsepower
BTDC	before top dead center	psi	pound(s) per square inch
°C	degree(s) Celsius	r	revolution
DC	direct current	rpm	revolution(s) per minute
F	farad(s)	TDC	top dead center
°F	degree(s) Fahrenheit	TIR	total indicator reading
ft	foot, feet	V	volt(s)
g	gram(s)	W	watt(s)
h	hour(s)	Ω	ohm(s)
L	liter(s)		

**Read OWNER'S MANUAL before operating.**

## EMISSION CONTROL INFORMATION

To protect the environment in which we all live, Kawasaki has incorporated crankcase emission (1) and exhaust emission (2) control systems in compliance with applicable regulations of the United States Environmental Protection Agency and California Air Resources Board.

### 1. Crankcase Emission Control System

A sealed-type crankcase emission control system is used to eliminate blow-by gases. The blow-by gases are led to the breather chamber through the crankcase. Then, it is led to the air cleaner.

Oil is separated from the gases while passing through the inside of the breather chamber from the crankcase, and then returned back to the bottom of the crankcase.

### 2. Exhaust Emission Control System

The exhaust emission control system applied to this engine family is engine modifications that consist of a modified carburetor and ignition system having optimum ignition timing characteristics. The carburetor has been calibrated to provide lean air/fuel mixture characteristics and optimum fuel economy with a suitable air cleaner and exhaust system.

A maintenance free ignition system provides the most favorable ignition timing and helps maintain a thorough combustion process within the engine which contributes to a reduction of exhaust pollutants entering the atmosphere.

The Clean Air Act, which is the Federal law covering motor vehicle pollution, contains what is commonly referred to as the Act's "tampering provisions."

"Sec. 203(a) The following acts and the causing thereof are prohibited...

(3)(A) for any person to remove or render inoperative any device or element of design installed on or in a motor vehicle or motor vehicle engine in compliance with regulations under this title prior to its sale and delivery to the ultimate purchaser, or for any manufacturer or dealer knowingly to remove or render inoperative any such device or element of design after such sale and delivery to the ultimate purchaser.

(3)(B) for any person engaged in the business of repairing, servicing, selling, leasing, or trading motor vehicles or motor vehicle engines, or who operates a fleet of motor vehicles knowingly to remove or render inoperative any device or element of design installed on or in a motor vehicle or motor vehicle engine in compliance with regulations under this title following its sale and delivery to the ultimate purchaser..."

(Continued on next page.)

#### **NOTE**

○The phrase "remove or render inoperative any device or element of design" has been generally interpreted as follows:

1. Tampering does not include the temporary removal or rendering inoperative of devices or elements of design in order to perform maintenance.
2. Tampering could include:
  - a. Maladjustment of vehicle components such that the emission standards are exceeded.
  - b. Use of replacement parts or accessories which adversely affect the performance or durability of the vehicle.
  - c. Addition of components or accessories that result in the vehicle exceeding the standards.
  - d. Permanently removing, disconnecting, or rendering inoperative any component or element of design of the emission control systems.

**WE RECOMMEND THAT ALL DEALERS OBSERVE THESE PROVISIONS OF FEDERAL LAW, THE VIOLATION OF WHICH IS PUNISHABLE BY CIVIL PENALTIES NOT EXCEEDING \$10,000 PER VIOLATION.**

**PLEASE DO NOT TAMPER WITH NOISE CONTROL SYSTEM  
(US Model only)**

To minimize the noise emissions from this product, Kawasaki has equipped it with effective intake and exhaust silencing systems. They are designed to give optimum performance while maintaining a low noise level. Please do not remove these systems, or alter them in any way which results in an increase in noise level.



# Foreword

This manual is designed primarily for use by trained mechanics in a properly equipped shop. However, it contains enough detail and basic information to make it useful to the owner who desires to perform his own basic maintenance and repair work. A basic knowledge of mechanics, the proper use of tools, and workshop procedures must be understood in order to carry out maintenance and repair satisfactorily. Whenever the owner has insufficient experience or doubts his ability to do the work, all adjustments, maintenance, and repair should be carried out only by qualified mechanics.

In order to perform the work efficiently and to avoid costly mistakes, read the text, thoroughly familiarize yourself with the procedures before starting work, and then do the work carefully in a clean area. Whenever special tools or equipment are specified, do not use makeshift tools or equipment. Precision measurements can only be made if the proper instruments are used, and the use of substitute tools may adversely affect safe operation.

**For the duration of the warranty period,** we recommend that all repairs and scheduled maintenance be performed in accordance with this service manual. Any owner maintenance or repair procedure not performed in accordance with this manual may void the warranty.

To get the longest life out of your vehicle:

- Follow the Periodic Maintenance Chart in the Service Manual.
- Be alert for problems and non-scheduled maintenance.
- Use proper tools and genuine Kawasaki Vehicle parts. Special tools, gauges, and testers that are necessary when servicing Kawasaki vehicles are introduced by the Special Tool Catalog or Manual. Genuine parts provided as spare parts are listed in the Parts Catalog.
- Follow the procedures in this manual carefully. Don't take shortcuts.
- Remember to keep complete records of maintenance and repair with dates and any new parts installed.

---

## How to Use This Manual

---

In this manual, the product is divided into its major systems and these systems make up the manual's chapters. The Quick Reference

Guide shows you all of the product's system and assists in locating their chapters. Each chapter in turn has its own comprehensive Table of Contents.

For example, if you want ignition coil information, use the Quick Reference Guide to locate the Electrical System chapter. Then, use the Table of Contents on the first page of the chapter to find the Ignition Coil section.

Whenever you see these WARNING and CAUTION symbols, heed their instructions! Always follow safe operating and maintenance practices.

### WARNING

**This warning symbol identifies special instructions or procedures which, if not correctly followed, could result in personal injury, or loss of life.**

### CAUTION

**This caution symbol identifies special instructions or procedures which, if not strictly observed, could result in damage to or destruction of equipment.**

This manual contains four more symbols (in addition to WARNING and CAUTION) which will help you distinguish different types of information.

### NOTE

○ *This note symbol indicates points of particular interest for more efficient and convenient operation.*

- Indicates a procedural step or work to be done.
- Indicates a procedural sub-step or how to do the work of the procedural step it follows. It also precedes the text of a NOTE.
- ★ Indicates a conditional step or what action to take based on the results of the test or inspection in the procedural step or sub-step it follows.

In most chapters an exploded view illustration of the system components follows the Table of Contents. In these illustrations you will find the instructions indicating which parts require specified tightening torque, oil, grease or a locking agent during assembly.



# General Information

## Table of Contents

Before Servicing .....	1-2
Model Identification.....	1-7
General Specifications.....	1-8
Unit Conversion Table .....	1-11

## 1-2 GENERAL INFORMATION

### Before Servicing

Before starting to perform an inspection service or carry out a disassembly and reassembly operation on a vehicle, read the precautions given below. To facilitate actual operations, notes, illustrations, photographs, cautions, and detailed descriptions have been included in each chapter wherever necessary. This section explains the items that require particular attention during the removal and reinstallation or disassembly and reassembly of general parts.

Especially note the following:

#### *Battery Ground*

Before completing any service on the vehicle, disconnect the battery wires from the battery to prevent the engine from accidentally turning over. Disconnect the ground wire (-) first and then the positive (+). When completed with the service, first connect the positive (+) wire to the positive (+) terminal of the battery then the negative (-) wire to the negative terminal.

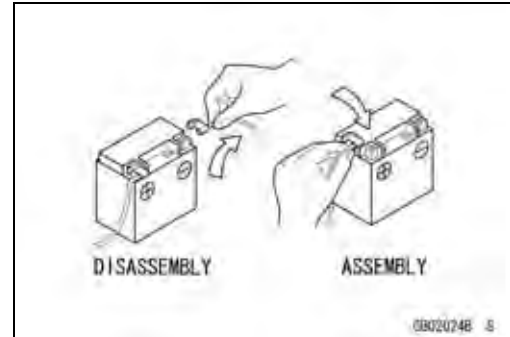

#### *Edges of Parts*

Lift large or heavy parts wearing gloves to prevent injury from possible sharp edges on the parts.

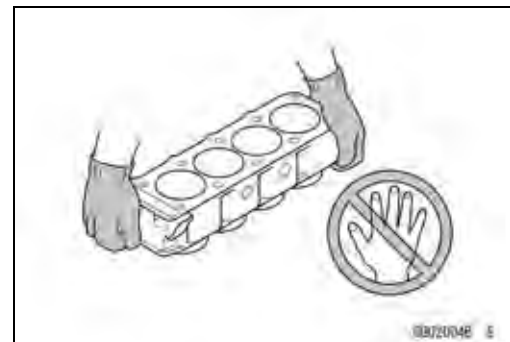

#### *Solvent*

Use a high-flash point solvent when cleaning parts. High-flash point solvent should be used according to directions of the solvent manufacturer.

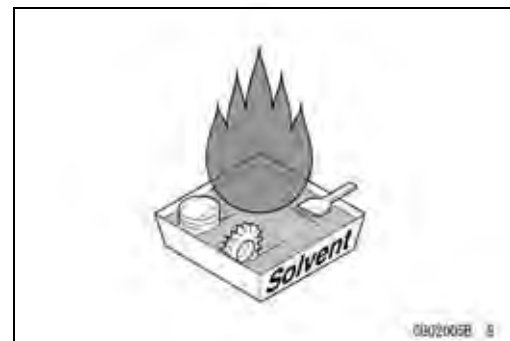

#### *Cleaning vehicle before disassembly*

Clean the vehicle thoroughly before disassembly. Dirt or other foreign materials entering into sealed areas during vehicle disassembly can cause excessive wear and decrease performance of the vehicle.



**Before Servicing**

*Arrangement and Cleaning of Removed Parts*

Disassembled parts are easy to confuse. Arrange the parts according to the order the parts were disassembled and clean the parts in order prior to assembly.

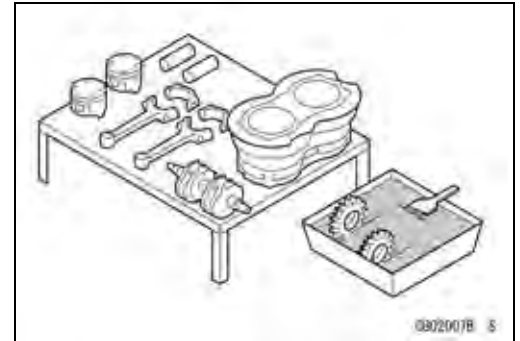

*Storage of Removed Parts*

After all the parts including subassembly parts have been cleaned, store the parts in a clean area. Put a clean cloth or plastic sheet over the parts to protect from any foreign materials that may collect before re-assembly.

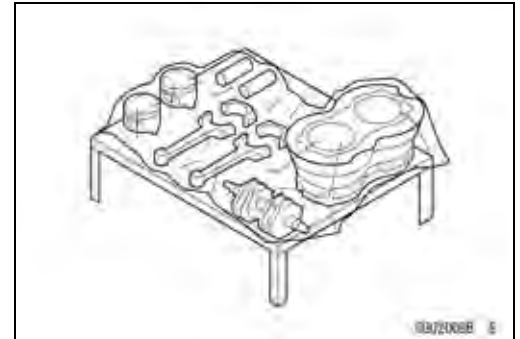

*Inspection*

Reuse of worn or damaged parts may lead to serious accident. Visually inspect removed parts for corrosion, discoloration, or other damage. Refer to the appropriate sections of this manual for service limits on individual parts. Replace the parts if any damage has been found or if the part is beyond its service limit.



*Replacement Parts*

Replacement Parts must be KAWASAKI genuine or recommended by KAWASAKI. Gaskets, O-rings, Oil seals, Grease seals, circlips or cotter pins must be replaced with new ones whenever disassembled.

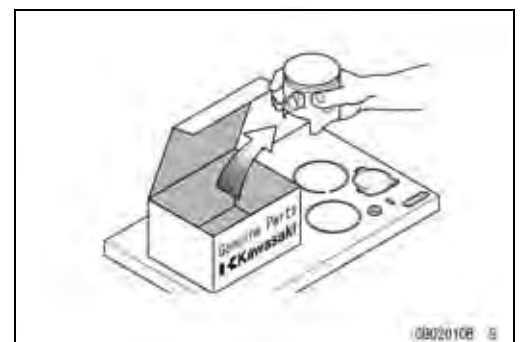

*Assembly Order*

In most cases assembly order is the reverse of disassembly, however, if assembly order is provided in this Service Manual, follow the procedures given.

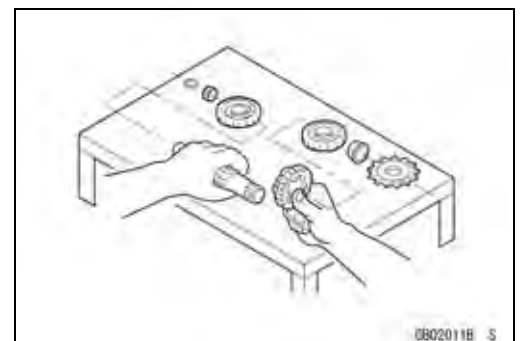

## 1-4 GENERAL INFORMATION

### Before Servicing

#### *Tightening Sequence*

Generally, when installing a part with several bolts, nuts, or screws, start them all in their holes and tighten them to a snug fit. Then tighten them according to the specified sequence to prevent case warpage or deformation which can lead to malfunction. Conversely when loosening the bolts, nuts, or screws, first loosen all of them by about a quarter turn and then remove them. If the specified tightening sequence is not indicated, tighten the fasteners alternating diagonally.

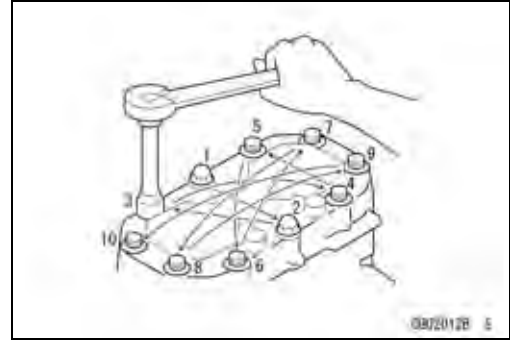

#### *Tightening Torque*

Incorrect torque applied to a bolt, nut, or screw may lead to serious damage. Tighten fasteners to the specified torque using a good quality torque wrench.

Often, the tightening sequence is followed twice initial tightening and final tightening with torque wrench.

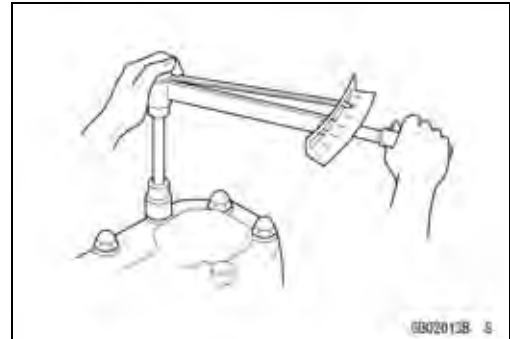

#### *Force*

Use common sense during disassembly and assembly, excessive force can cause expensive or hard to repair damage. When necessary, remove screws that have a non-permanent locking agent applied using an impact driver. Use a plastic-faced mallet whenever tapping is necessary.

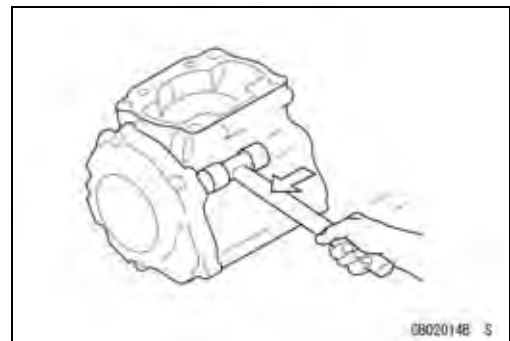

#### *Gasket, O-ring*

Hardening, shrinkage, or damage of both gaskets and O-rings after disassembly can reduce sealing performance. Remove old gaskets and clean the sealing surfaces thoroughly so that no gasket material or other material remains. Install new gaskets and replace used O-rings when re-assembling.

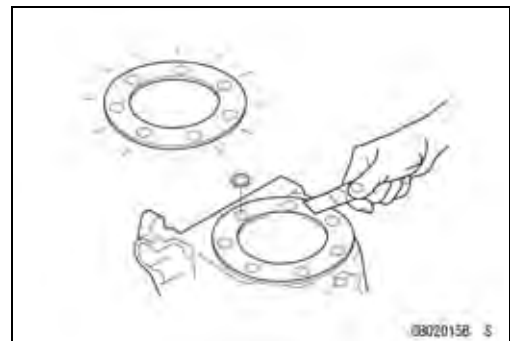

#### *Liquid Gasket, Locking Agent*

For applications that require Liquid Gasket or a Non-Permanent Locking Agent, clean the surfaces so that no oil residue remains before applying liquid gasket or locking agent. Do not apply them excessively. Excessive application can clog oil passages and cause serious damage.



**Before Servicing**

*Press*

For items such as bearings or oil seals that must be pressed into place, apply small amount of oil to the contact area. Be sure to maintain proper alignment and use smooth movements when installing.

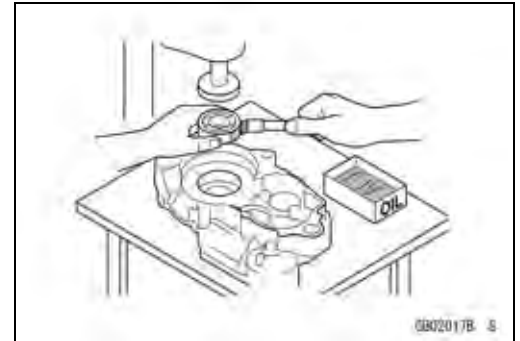

*Ball Bearing and Needle Bearing*

Do not remove pressed ball or needle unless removal is absolutely necessary. Replace with new ones whenever removed. Press bearings with the manufacturer and size marks facing out. Press the bearing into place by putting pressure on the correct bearing race as shown.

Pressing the incorrect race can cause pressure between the inner and outer race and result in bearing damage.

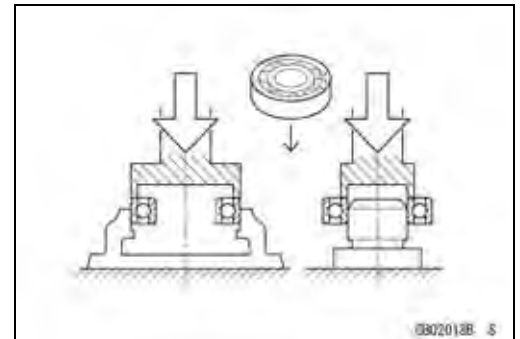

*Oil Seal, Grease Seal*

Do not remove pressed oil or grease seals unless removal is necessary. Replace with new ones whenever removed. Press new oil seals with manufacture and size marks facing out. Make sure the seal is aligned properly when installing.

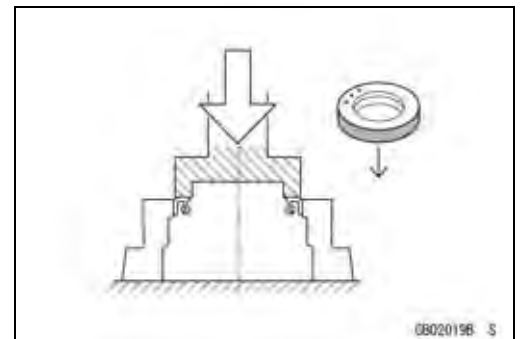

Apply specified grease to the lip of seal before installing the seal.

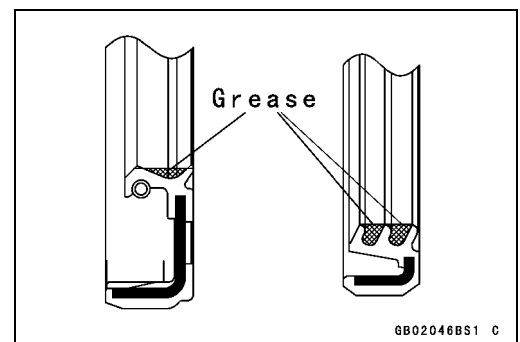

*Circlips, Cotter Pins*

Replace circlips or cotter pins that were removed with new ones. Take care not to open the clip excessively when installing to prevent deformation.

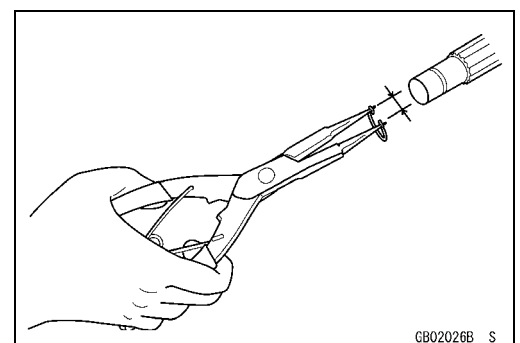

## 1-6 GENERAL INFORMATION

### Before Servicing

#### *Lubrication*

It is important to lubricate rotating or sliding parts during assembly to minimize wear during initial operation. Lubrication points are called out throughout this manual, apply the specific oil or grease as specified.

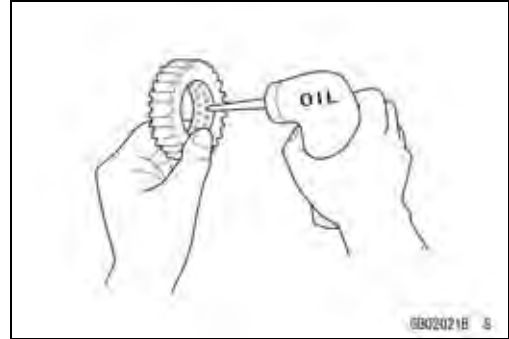

#### *Direction of Engine Rotation*

When rotating the crankshaft by hand, the free play amount of rotating direction will affect the adjustment. Rotate the crankshaft to positive direction (clockwise viewed from output side).

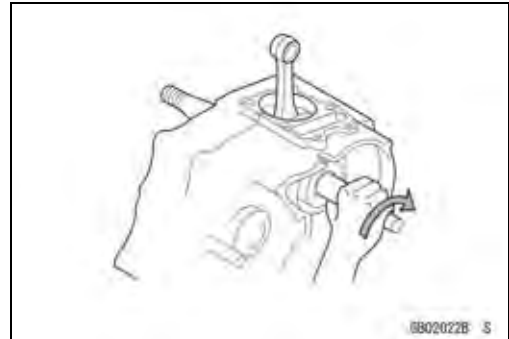

#### *Electrical Wires*

A two-color wire is identified first by the primary color and then the stripe color. Unless instructed otherwise, electrical wires must be connected to those of the same color.

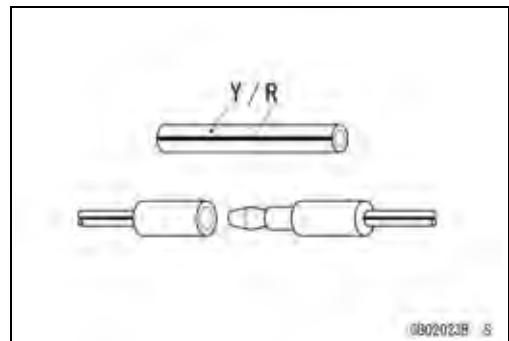



Model Identification

KAF620-J1 Left Side View



KAF620-J1 Right Side View



The KAF620-K1 is a camouflage-surface-treated model and identical to the KAF620-J1, the base model, in every other aspect: controls, features, and specifications.

# 1-8 GENERAL INFORMATION

## General Specifications

Items	KAF620-J1/K1
<b>Dimensions</b>	
Overall Length	3 169 mm (124.76 in.)
Overall Width	1 449 mm (57.05 in.)
Overall Height	1 933 mm (76.10 in.)
Wheelbase	2 165 mm (85.24 in.)
Track:	
Front	1 160 mm (45.67 in.)
Rear	1 180 mm (46.46 in.)
Ground Clearance	177 mm (6.97 in.)
Seat Height:	
Front	868 mm (34.17 in.)
Rear	896 mm (35.28 in.)
Dry Weight	668 kg (1 473 lb)
Curb Weight:	
Front	321 kg (708 lb)
Rear	374 kg (825 lb)
Fuel Tank Capacity	24.2 L (6.4 US gal)
Cargo Bed (L x W x H):	
Long Bed	1 280 x 1 212 x 287 mm (50.39 x 47.72 x 11.30 in.)
Short Bed	770 x 1 212 x 287 mm (30.31 x 47.72 x 11.30 in.)
<b>Performance</b>	
Maximum Torque	47 N·m (4.8 kgf·m, 34.7 ft·lb) @2 500 r/min (rpm), (US) –
Minimum Turning Radius	3.8 m (12.5 ft)
<b>Engine</b>	
Type	4-stroke, OHV, 2 cylinder
Cooling System	Liquid-cooled
Bore And Stroke	76 x 68 mm (2.99 x 2.68 in.)
Displacement	617 mL (37.6 cu in.)
Compression Ratio	10.3
Carburetion System	MIKUNI BW26-18
Starting System	Electric Starter
Ignition System	Battery and transistor
Ignition Timing	3/900 ~ 13/2 000 ~ 18/2 500 ~ 23/3 500 (BTDC°/rpm)
Spark Plug	NGK BPR2ES
Cylinder Numbering Method	Front to rear, 1-2
Firing Order	Front to rear, 1-2
Valve Timing:	
Inlet:	
open	#1 68° BTDC/#2 64° BTDC
close	#1 76° ABDC/#2 80° ABDC
duration	324°
Exhaust:	
open	94° BBDC
close	48° ABDC

**General Specifications**

Items	KAF620-J1/K1
duration Lubrication System Engine Oil: Grade Viscosity Capacity Coolant Capacity	322° Forced lubrication (wet sump) API SF or SG, API SH or SJ with JASO MA 10W-40 1.8 L (1.9 US qt) 4.6 L (4.9 US qt)
<b>Drive Train</b> Primary Reduction System: Type Reduction Ratio Transmission Gear Ratio: Forward: High Low Reverse: Low Final Drive System: Type Reduction Ratio Overall Drive Ratio: Forward: High Low Reverse: Low Front Final Gear Case Oil: Type Capacity Transmission Oil: Type Capacity	Belt drive torque converter 3.9 ~ 0.85 1.821 (51/28) 3.750 (51/28 × 25/20 × 28/17) 4.220 (41/20 × 25/20 × 28/17) 2-speed, automatic, reverse gear drive (4WD/2WD) 5.4 (81/15) 8.360 17.212 19.372 API GL-5 or GL-6 Hypoid gear oil for LSD SAE 85W-140, SAE 90, or SAE 140 0.4 L (0.4 US qt) API GL-5 Hypoid gear oil, SAE 90 (above 5°C, 41°F) or SAE 80 (below 5°C, 41°F) 2.5 L (2.6 US qt)
<b>Frame</b> Type Caster (Rake Angle) Camber Trail Tire: Front And Rear Steering Type	Steel tube, Ladder 7.5° 0.8° 35 mm (1.4 in.) 23 × 11.00-10, Tubeless Rack and pinion

## 1-10 GENERAL INFORMATION

### General Specifications

Items	KAF620-J1/K1
Suspension: Front: Type Wheel Travel Rear: Type Wheel Travel Brake Type: Front And Rear Parking Brake Type	MacPherson strut 100 mm (3.9 in.) De Dion axle 70 mm (2.8 in.) Drum (Hydraulic) Drum (Mechanical internal expansion)
<b>Electrical Equipment</b> Battery Headlight: Type Bulb Tail/Brake Light Alternator: Type Rated Output	12 V 18 Ah Semi-sealed beam 12 V 30 W x 2 12 V 5/21 W Three - phase AC 21 A /12 V @3 000 rpm
<b>Load Capacity</b> Maximum Vehicle Load (Including Occupants And Cargo) Maximum Cargo Bed Load: Long Short	603 kg (1330 lb) 363 kg (800 lb) 182 kg (401 lb)

US: United States Model

Specifications are subject to change without notice, and may not apply to every country.

**Unit Conversion Table**

**Prefixes for Units:**

Prefix	Symbol	Power
mega	M	× 1 000 000
kilo	k	× 1 000
centi	c	× 0.01
milli	m	× 0.001
micro	μ	× 0.000001

**Units of Mass:**

kg	×	2.205	=	lb
g	×	0.03527	=	oz

**Units of Volume:**

L	×	0.2642	=	gal (US)
L	×	0.2200	=	gal (imp)
L	×	1.057	=	qt (US)
L	×	0.8799	=	qt (imp)
L	×	2.113	=	pint (US)
L	×	1.816	=	pint (imp)
mL	×	0.03381	=	oz (US)
mL	×	0.02816	=	oz (imp)
mL	×	0.06102	=	cu in

**Units of Force:**

N	×	0.1020	=	kg
N	×	0.2248	=	lb
kg	×	9.807	=	N
kg	×	2.205	=	lb

**Units of Length:**

km	×	0.6214	=	mile
m	×	3.281	=	ft
mm	×	0.03937	=	in

**Units of Torque:**

N·m	×	0.1020	=	kgf·m
N·m	×	0.7376	=	ft·lb
N·m	×	8.851	=	in·lb
kgf·m	×	9.807	=	N·m
kgf·m	×	7.233	=	ft·lb
kgf·m	×	86.80	=	in·lb

**Units of Pressure:**

kPa	×	0.01020	=	kgf/cm <sup>2</sup>
kPa	×	0.1450	=	psi
kPa	×	0.7501	=	cmHg
kgf/cm <sup>2</sup>	×	98.07	=	kPa
kgf/cm <sup>2</sup>	×	14.22	=	psi
cmHg	×	1.333	=	kPa

**Units of Speed:**

km/h	×	0.6214	=	mph
------	---	--------	---	-----

**Units of Power:**

kW	×	1.360	=	PS
kW	×	1.341	=	HP
PS	×	0.7355	=	kW
PS	×	0.9863	=	HP

**Units of Temperature:**

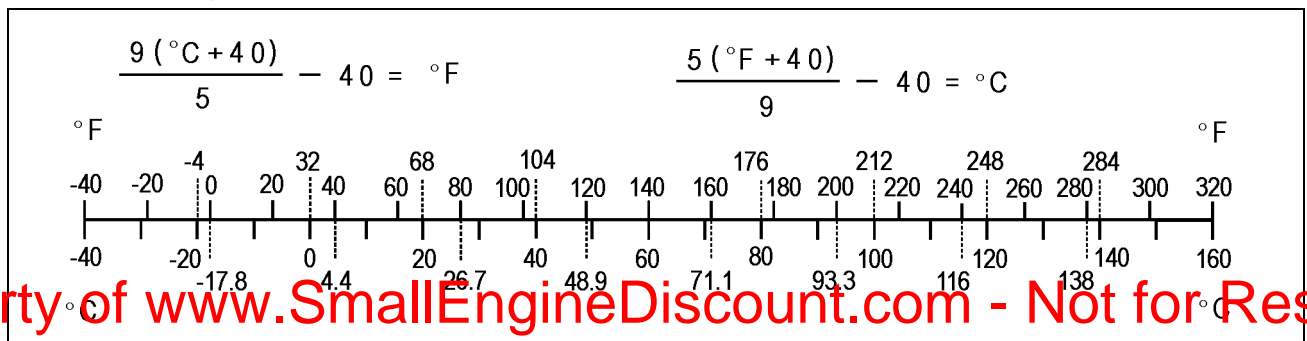



# Periodic Maintenance

## Table of Contents

Periodic Maintenance Chart .....	2-2	Spark Arrester Cleaning.....	2-22
Torque and Locking Agent.....	2-4	Engine Lubrication .....	2-22
Specifications .....	2-8	Oil and/or Filter Change.....	2-22
Special Tools .....	2-10	Oil Filter Removal .....	2-23
Periodic Maintenance Procedures....	2-11	Oil Filter Installation .....	2-23
Fuel System.....	2-11	Transmission .....	2-24
Throttle Pedal Free Play		Transmission Oil Change.....	2-24
Inspection.....	2-11	Wheels/Tires.....	2-24
Throttle Pedal Free Play		Wheels Nuts Tightness	
Adjustment .....	2-11	Inspection.....	2-24
Full Throttle Pedal Position		Tire Inspection .....	2-25
Adjustment .....	2-12	Final Drive.....	2-25
Idle Speed Inspection .....	2-12	Front Final Gear Case Oil	
Idle Speed Adjustment.....	2-12	Change.....	2-25
Fuel System Cleanliness		Brakes.....	2-26
Inspection.....	2-12	Brake Fluid Level Inspection .....	2-26
Fuel Filter Inspection.....	2-13	Brake Fluid Changing .....	2-27
Intake Chamber Water Draining ..	2-13	Brake Pedal Free Play	
External Carburetor Mechanism		Adjustment .....	2-27
Cleaning.....	2-13	Brake Master Cylinder Cup and	
Fuel Hoses And Connections		Dust Seal Replacement .....	2-28
Inspection.....	2-13	Brake Hose and Pipe Inspection..	2-29
Fuel Hoses Replacement.....	2-14	Brake Hose and Pipe	
Air Cleaner Element Cleaning.....	2-14	Replacement.....	2-29
Air Cleaner Housing Dust and/or		Brake Wear Inspection.....	2-30
Water Inspection .....	2-15	Brake Wheel Cylinder Assembly	
Cooling System.....	2-15	Replacement.....	2-31
Radiator Cleaning .....	2-15	Parking Brake Lever Travel	
Radiator Hose and Connection		Adjustment .....	2-33
Inspection.....	2-16	Steering .....	2-34
Coolant Draining .....	2-16	Steering Wheel Free Play	
Coolant Filling .....	2-17	Inspection.....	2-34
Coolant Filter Inspection .....	2-18	Steering Joint Dust Boot	
Converter System.....	2-18	Inspection.....	2-34
Drive Belt Inspection .....	2-18	Frame .....	2-34
Converter Driven Pulley Shoe		Seat Belt Inspection .....	2-34
Inspection.....	2-19	Electrical System .....	2-35
Air Cleaner Element		Brake Light Switch Adjustment ...	2-35
Cleaning/Inspection.....	2-19	Spark Plug Cleaning/Inspection...	2-35
Converter Dust or Water Draining		Spark Plug Gap Inspection .....	2-35
Engine Top End .....	2-20	General Lubrication .....	2-35
Valve Clearance Inspection .....	2-20	Bolts, Nuts, and Fasteners .....	2-37
Valve Clearance Adjustment.....	2-21	Tightness Inspection .....	2-37

## 2-2 PERIODIC MAINTENANCE

### Periodic Maintenance Chart

The scheduled maintenance must be done in accordance with this chart to keep the vehicle in good running condition. **The initial maintenance is vitally important and must not be neglected.**

OPERATION	FREQUENCY	Which ever comes first → ↓ Every	First Service	Regular Service		See Page
			After 50 h, or 1 000 km of use	Every 250 h, or 5 000 km of use	Every 500 h, or 10 000 km of use	
<b>ENGINE</b>						
Converter belt - check*			●			2-18
Converter driven pulley shoe - check*					●	2-19
Converter air cleaner element - clean*			●	●		2-19
Converter dust or water - drain*					●	2-20
Valve clearance - check			●		●	2-20
Engine oil - change*	1 year		●	●		2-22
Oil filter - replace*			●		●	2-23
Throttle pedal play - check			●		●	2-11
Idle speed - adjust			●	●		2-12
External carburetor mechanism (Throttle lever roller and choke lever cam) - clean*			●	●		2-13
Fuel hose and connections - check*			●	●		2-13
Fuel hose - replace	4 years					2-14
Fuel filter - change*					●	2-13
Fuel system cleanliness - check*					●	2-12
Air cleaner element - clean*			●	●		2-14
Intake chamber water - drain*			●	●		2-13
Spark plug - clean and gap				●		2-35
Spark arrester - clean				●		2-22
Radiator - clean*			●	●		2-15
Radiator hoses and connections - check	1 year		●		●	2-16
Coolant - change	2 years					2-16
Coolant filter - clean	1 year					2-18

●: Clean, adjust, lubricate, torque, or replace parts as necessary.

\*: Service more frequently when operated in mud, dust, or other harsh riding conditions.



**Periodic Maintenance Chart**

OPERATION	FREQUENCY	Whichever comes first → ↓ Every	First Service	Regular Service		See Page
			After 50 h, or 1 000 km of use	Every 250 h, or 5 000 km of use	Every 500 h, or 10 000 km of use	
<b>CHASSIS</b>						
Steering - check			●	●		2-34
Steering and axle shaft joint dust boots - check			●	●		2-35
Brake pedal play - check*			●	●		2-27
Parking brake lever - check			●	●		2-33
Brake hose and pipe - check			●	●		2-29
Brake fluid level - check			●	●		2-26
Brake wear - check*				●		2-30
Tire wear - check*			●	●		2-25
Brake light switch - check			●	●		2-35
Seat belt - check				●		2-34
General lubrication - perform*				●		2-35
Bolts, nuts, and fasteners tightness - check			●	●		2-37
Wheel nuts tightness - check			●	●		2-24
Front final gear case oil and transmission oil - change*		1 year	●		●	2-25
Brake fluid - change		2 years				2-27
Brake master cylinder cup and dust seal - replace		2 years				2-28
Brake wheel cylinder assembly - replace		2 years				2-31
Brake hose - replace		4 years				2-29

●: Clean, adjust, lubricate, torque, or replace parts as necessary.

\*: Service more frequently when operated in mud, dust, or other harsh riding conditions.

## 2-4 PERIODIC MAINTENANCE

### Torque and Locking Agent

The following tables list the tightening torque for the major fasteners, and the parts requiring use of a non-permanent locking agent or liquid gasket.

Letters used in the "Remarks" column mean:

L: Apply a non-permanent locking agent to the threads.

MO: Apply molybdenum disulfide oil solution (mixture of the engine oil and molybdenum disulfide grease in a weight ratio 10:1).

O: Apply an oil to the threads, seated surface, or washer.

R: Replacement Part

S: Tighten the fasteners following the specified sequence.

SS: Apply a silicone sealant to the threads.

Fastener	Torque			Remarks
	N·m	kgf·m	ft·lb	
<b>Fuel System</b>				
Air Duct Clamps	1.0	0.10	8.7	
Cover Mounting Bolts	2.9	0.30	26 in·lb	L
Chamber Case Cover Bolts	4.9	0.50	43 in·lb	
Float Bowl Screws	2.0	0.20	18 in·lb	
Air Cleaner Housing Mounting Bolts	20	2.0	14	
Governor Arm Mounting Nut	7.4	0.75	65 in·lb	
Link Lever Mounting Bolts	8.8	0.90	78 in·lb	L
Carburetor Cover Bolts	8.8	0.90	78 in·lb	
<b>Cooling System</b>				
Water Pump Cover Bolts (M6)	8.8	0.90	78 in·lb	S
Water Pump Cover Bolt (M8)	25	2.5	18	S
Radiator Fan Switch	25	2.5	18	
Radiator Screen Bolts	8.8	0.90	78 in·lb	
Radiator Mounting Bolts	8.8	0.90	78 in·lb	
Water Pipe Bolts	8.8	0.90	78 in·lb	
Coolant Temperature Warning Light Switch	23	2.3	17	SS
Coolant Reservoir Mounting Bolt	4.4	0.45	39 in·lb	
Coolant Drain Plugs (Cylinder)	17	1.7	12	
<b>Engine Top End</b>				
Cylinder Head Bolts	22	2.2	16	S
Intake Pipe Bolts	8.8	0.90	78 in·lb	L (2)
Valve Adjusting Screw Locknuts	9.8	1.0	87 in·lb	
Coolant Temperature Warning Light Switch	23	2.3	17	SS
Intake Manifold Bolts	–	–	–	S
Muffler Mounting Bolts	–	–	–	L
<b>Converter System</b>				
Drive Pulley Bolt (New)	76	7.7	56	R
Driven Pulley Bolt	93	9.5	69	L
Converter Cover Bolts	1.5	0.15	13 in·lb	
Ramp Weight Nuts	6.9	0.70	61 in·lb	
Spider	275	28	203	
Drive Pulley Cover Bolts	1.3	0.13	113 in·lb	
Wear Shoe Mounting Screws	1.1	0.11	10 in·lb	

**Torque and Locking Agent**

Fastener	Torque			Remarks
	N-m	kgf-m	ft-lb	
Cooling Fan Cover Bolts	8.8	0.90	78 in-lb	
<b>Engine Lubrication System</b>				
Engine Oil Drain Plug (M14)	22	2.2	16	
Engine Oil Drain Plug (M16)	25	2.5	18	
Oil Pressure Switch	9.8	1.0	87 in-lb	SS
Oil Filter	–	–	–	see text
<b>Engine Removal/Installation</b>				
Engine Positioning Plate Bolts	20	2.0	14	
<b>Engine Bottom End</b>				
Crankcase Cover Bolts	25	2.5	18	
Connecting Rod Big End Cap Bolts	21	2.1	15	O
Coolant Drain Plugs (Cylinder)	17	1.7	12	
Oil Filter Stud Bolt	18	1.8	13	
<b>Transmission</b>				
Transmission Oil Drain Plug	15	1.5	11	
Transmission Case Mounting Bolts	44	4.5	33	
Transmission Case Bolts	8.8	0.90	78 in-lb	
Shift Arm Positioning Bolt	37	3.8	27	
Hi/Low Gear Case Bolts	20	2.0	14	
Shift Shaft Stop Bolt	7.8	0.80	69 in-lb	
Differential Gear Housing Bolts	57	5.8	42	
Bearing Holder	120	12	87	MO
Neutral Switch	15	1.5	11	
Governor Pivot Arm Stopper Bolt	15	1.5	11	
Shift Shaft Lever Clamp Bolts	12	1.2	104 in-lb	
<b>Wheels/Tires</b>				
Tie-Rod End Locknuts	49	5.0	36	
Wheel Nuts	137	14	101	
<b>Final Drive</b>				
Front Final Gear Case:				
Oil Filler Cap	29	3.0	22	
Oil Drain Plug	20	2.0	14	
Gear Case Bracket Bolts	44	4.5	33	L
Gear Case Mounting Nuts	44	4.5	33	
Ring Gear Cover Bolts (M10)	47	4.8	35	
Ring Gear Cover Bolts (M8)	25	2.5	18	
Pinion Gear Bearing Housing Nuts	25	2.5	18	
Differential Case Torx Bolts	32	3.3	24	L
Ring Gear Bolts	49	5.0	36	
Pinion Gear Slotted Nut	120	12	87	MO
Bevel Gear Case:				
Bevel Gear Case Bolts	22	2.2	16	
Driven Gear Shaft Nut	110	11	80	L

## 2-6 PERIODIC MAINTENANCE

### Torque and Locking Agent

Fastener	Torque			Remarks
	N-m	kgf-m	ft-lb	
Bearing Holder	120	12	87	L
Housing Locknut	120	12	87	L
Bevel Gear Case Holder Nuts	25	2.5	18	
Drive Gear Nut	120	12	87	MO
Front Axle Cap Bolts	8.8	0.90	78 in-lb	
Drive Shaft Cap Bolts	20	2.0	14	
<b>Brakes</b>				
Bleed Valves	5.9	0.60	52 in-lb	
Push Rod Locknut	18	1.8	13	
Brake Hose Banjo Bolts	25	2.5	18	
Brake Pipe Nipples	18	1.8	13	
Piston Stop Bolt	8.8	0.90	78 in-lb	
Reservoir Clamp Bolt	5.9	0.60	52 in-lb	
Front Axle Nuts	200	20	140	
Rear Axle Nuts	300	31	220	
Wheel Cylinder Mounting Bolts	11	1.1	95 in-lb	
Wheel Cylinder Mounting Nuts	7.8	0.80	69 in-lb	
Brake Panel Mounting Bolts	44	4.5	33	L
<b>Suspension</b>				
Strut Mounting Nuts	44	4.5	33	
Strut Clamp Nut	98	10	72	
Strut Lock Nut	49	5.0	36	
Rear Shock Absorber Mounting Nuts	59	6.0	43	
Front Suspension Arm Pivot Bolts	98	10	72	
Front Suspension Arm Joint Nut	78	8.0	58	
Damper Bracket Mounting Nuts	44	4.5	33	
Leaf Spring Mounting Nuts (Front)	98	10	72	
Leaf Spring Mounting Nuts (Rear)	59	6.0	43	
Tie-rod End Nuts	34	3.5	25	
<b>Steering</b>				
Steering Wheel Mounting Nut	52	5.3	38	
Intermediate Shaft Clamp Bolts	20	2.0	14	
Steering Gear Assembly Bracket Bolts	52	5.3	38	L
Tie-rod End Nuts	34	3.5	25	
Rack Guide Spring Cap Locknut	39	4.0	29	
Tie-Rod End Locknuts	49	5.0	36	
Strut Clamp Nut	98	10	72	
<b>Frame</b>				
Seat Belt Mounting Bolts	34	3.5	25	
Front Bar Mounting Bolts (Lower)	98	10	72	
Front Bar Mounting Bolts (Upper)	44	4.5	33	
Top Bar Mounting Bolts	44	4.5	33	
Center Bar Mounting Bolts and Nuts	44	4.5	33	

**Torque and Locking Agent**

Fastener	Torque			Remarks
	N-m	kgf-m	ft-lb	
Rear Bar Mounting Bolts And Nuts	44	4.5	33	
Rear End Sub-Frame Mounting Bolts	44	4.5	33	
Hood Latch Lever Mounting Bolt	39	4.0	29	
Tail Gate Fixing Lever Screw	4.4	0.45	39 in-lb	L
Screen Fixing Lever Screw	4.4	0.45	39 in-lb	L
<b>Electrical System</b>				
Alternator Rotor Nut	120	12	87	
Spark Plugs	17	1.7	12	
Starter Motor Mounting Bolts	22	2.2	16	
Regulator/Rectifier Mounting Bolts	8.8	0.90	78 in-lb	
Igniter Mounting Bolts	8.8	0.90	78 in-lb	
Alternator Stator Mounting Screws	-	-	-	L
Coolant Temperature Warning Light Switch	23	2.3	17	SS
Oil Pressure Switch	9.8	1.0	87 in-lb	SS
Neutral Switch	15	1.5	11	
Radiator Fan Switch	25	2.5	18	
Battery Holder Nuts	17	1.7	12	

The table below, relating tightening torque to thread diameter, lists the basic torque for the bolts and nuts. Use this table for only the bolts and nuts which do not require a specific torque value. All of the values are for use with dry solvent-cleaned threads.

**Basic Torque for General Fasteners of Engine Parts**

Threads dia. mm (in.)	Mark of bolt head	Torque		
		N-m	kgf-m	ft-lb
6 (0.24)	4T	3.9 ~ 4.9	0.40 ~ 0.50	35 ~ 43 in-lb
6 (0.24)	7T	7.8 ~ 9.8	0.80 ~ 1.0	69 ~ 87 in-lb
6 (0.24)	9T	12 ~ 15	1.2 ~ 1.5	104 ~ 130 in-lb
8 (0.31)	4T	10 ~ 14	1.0 ~ 1.4	87 ~ 120 in-lb
8 (0.31)	7T	18 ~ 22	1.8 ~ 2.2	13 ~ 16
10 (0.39)	4T	20 ~ 24	2.0 ~ 2.4	14 ~ 17
10 (0.39)	7T	39 ~ 44	4.0 ~ 4.5	29 ~ 33

**Basic Torque for General Fasteners of Frame Parts**

Threads dia. mm (in.)	Torque		
	N-m	kgf-m	ft-lb
5 (0.20)	3.4 ~ 4.9	0.35 ~ 0.50	30 ~ 43 in-lb
6 (0.24)	5.8 ~ 7.9	0.60 ~ 0.80	52 ~ 69 in-lb
8 (0.31)	14 ~ 19	1.4 ~ 1.9	10 ~ 14
10 (0.39)	26 ~ 34	2.6 ~ 3.5	19 ~ 25
12 (0.47)	44 ~ 61	4.5 ~ 6.2	33 ~ 45

## 2-8 PERIODIC MAINTENANCE

### Specifications

Item	Standard	Service Limit
<b>Fuel System</b>		
Throttle Pedal Free Play	5 ~ 10 mm (0.2 ~ 0.4 in.)	---
Idle Speed	850 ~ 950 r/min (rpm)	---
<b>Cooling System</b>		
Coolant:		
Type	Permanent type of antifreeze (Soft water and ethylene glycol plus corrosion and rust inhibitor chemicals for aluminum engine and radiators)	---
Color	Green	---
Mixed Ratio	Soft water 50% x coolant 50%	---
Freezing Point	-35°C (-31°F)	---
Total Amount	4.6 L (4.9 US qt)	---
Fan Belt Deflection	9.5 ~ 11.5 mm/10 kgf (22 lb)	---
<b>Converter System</b>		
Belt Width	30.3 mm (1.19 in.)	28.8 mm (1.13 in.)
Wear Shoe Width	---	16 mm (0.64 in.)
<b>Engine Top End</b>		
Valve Clearance (When Cold)	0.25 mm (0.010 in.)	---
<b>Engine Lubrication System</b>		
Engine Oil:		
Grade	API SF or SG API SH or SJ with JASO MA	---
Viscosity	SAE 10W-40	---
Capacity	1.5 L (1.6 US qt) (when filter is not removed) 1.8 L (1.9 US qt) (when filter is removed)	---
Oil Level	Between F and L marks on dipstick	---
<b>Transmission</b>		
Transmission Oil:		
Type	API "GL-5" Hypoid gear oil	---
Viscosity	SAE90: above 5°C (41°F) or SAE80: below 5°C (41°F)	---
Capacity	2.5 L (2.6 US qt)	---
Oil Level	Between H and L lines on dipstick	---
<b>Wheels/Tires</b>		
Tire Tread Depth	13.2 mm (0.520 in.)	3 mm (0.12 in.)
<b>Final Drive</b>		
Front Final Gear Case Oil:		
Type	API "GL-5 or GL-6" hypoid gear oil for LSD (Limited Slip Differential gears)	---
Viscosity	SAE85W-140, SAE90 or SAE140	---
Capacity	0.4 L (0.4 US qt)	---
Oil Level	Filler opening level	---

**Specifications**

Item	Standard	Service Limit
<b>Brakes</b>		
Brake Fluid:		
Type	DOT3	---
Fluid Level	Between upper and lower level lines	---
Brake Pedal Play	2 ~ 10 mm (0.08 ~ 0.39 in.)	---
Brake Drum Inside Diameter	180.000 ~ 180.160 mm (7.0866 ~ 7.0929 in.)	180.75 mm (7.116 in.)
Brake Shoe Lining Thickness	4.5 mm (0.18 in.)	1.0 mm (0.04 in.)
Parking Brake Lever Travel	8 ~ 12 notches (clicks) at 200 N (20 kgf, 44 lb)	---
<b>Steering</b>		
Steering Wheel Free Play	0 ~ 20 mm (0 ~ 0.79 in.)	---
<b>Electrical System</b>		
Brake Light Switch Timing	ON after 10 mm (0.39 in.) of pedal travel	---
Spark Plug Gap	0.7 ~ 0.8 mm (0.028 ~ 0.031 in.)	

## 2-10 PERIODIC MAINTENANCE

### Special Tools

**Inside Circlip Pliers:**  
57001-143

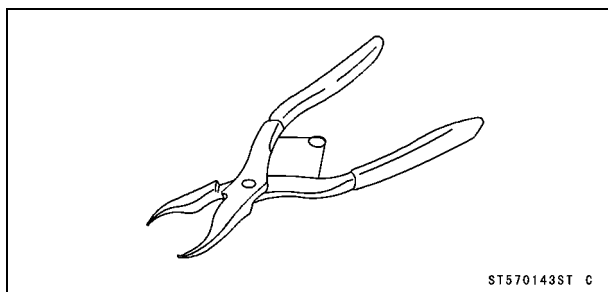

**Rotor Puller, M16/M18/M20/M22 x 1.5:**  
57001-1216

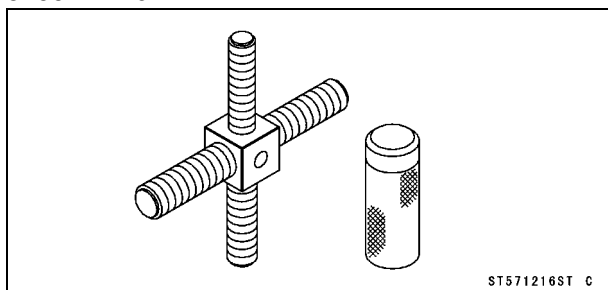

**Valve Adjusting Screw Holder:**  
57001-1217

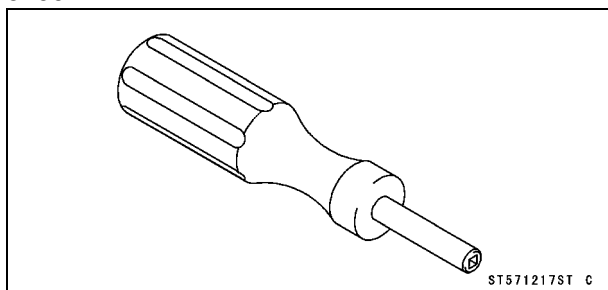

**Oil Filter Wrench:**  
57001-1249

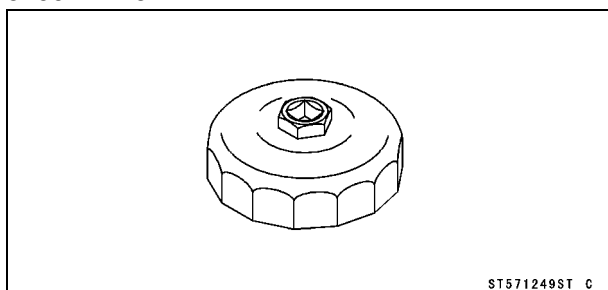

**Brake Drum Remover:**  
57001-1260

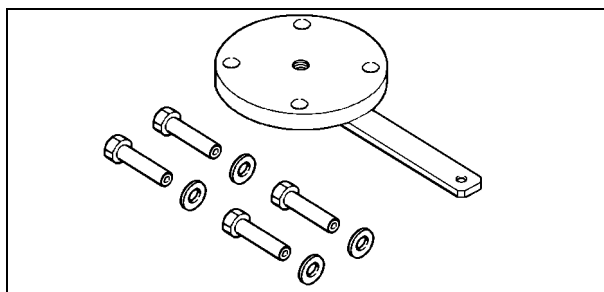

**Brake Drum Pusher, M18 x 1.5:**  
57001-1261

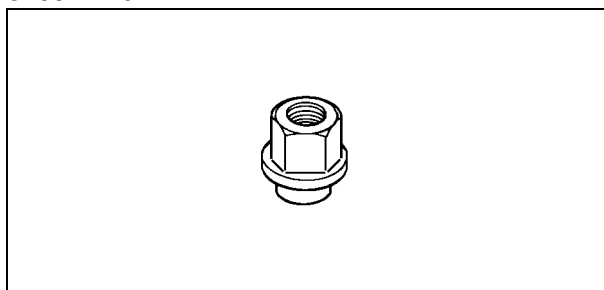

**Brake Drum Holder:**  
57001-1325

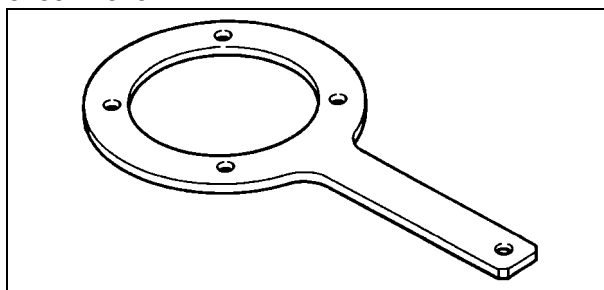

**Brake Drum Remover Nuts:**  
57001-1326

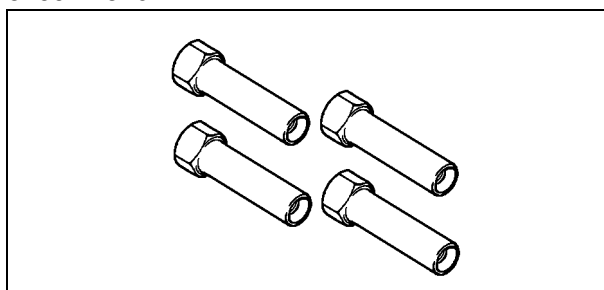



**Periodic Maintenance Procedures**

**Fuel System**

*Throttle Pedal Free Play Inspection*

- Check that the throttle pedal moves smoothly from full open to close.
- ★ If the throttle pedal does not return properly, lubricate the throttle cable.
- Check the throttle pedal free play [A].
- ★ If the free play is incorrect, adjust the throttle cable.

**Throttle Pedal Free Play**

**Standard: 5 ~ 10 mm (0.2 ~ 0.4 in.)**

*Throttle Pedal Free Play Adjustment*

- Remove:
  - Cargo Bed (tilt up)
- Loosen the adjuster mounting nuts [A] at the cable lower end.
- Slide the adjuster [B] until the proper amount of throttle pedal free play is obtained.
- Tighten the mounting nuts securely.
- Start the engine.
- With the transmission in neutral, operate the throttle pedal a few times to make sure that the idle speed does not change.
- ★ If the idle speed does change, the throttle cable may be improperly adjusted, incorrectly routed, or it may be damaged.
- Correct any of these conditions before operation.



**⚠ WARNING**

**Operation with improperly adjusted, incorrectly routed, or a damaged cable could result in an unsafe operating condition.**

**NOTE**

○ If the throttle pedal free play cannot be adjusted by using the adjuster at the cable lower end, use the cable adjuster [A] at the cable upper end. Do not forget to securely tighten the adjuster mounting nuts [B].

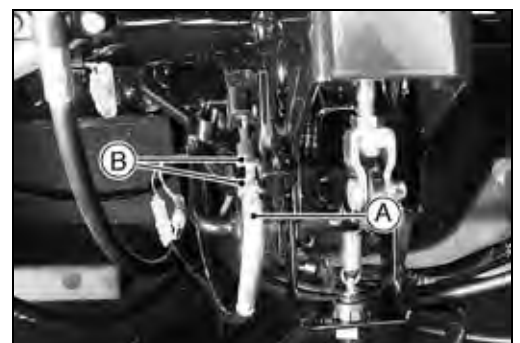

## 2-12 PERIODIC MAINTENANCE

### Periodic Maintenance Procedures

#### Full Throttle Pedal Position Adjustment

- Loosen the locknut [A].
- Screw in the throttle pedal stop bolt [B].
- Depress the throttle pedal until the throttle lever on the carburetor is in the fully opened position, and keep its position.
- Turn the throttle pedal stop bolt until the bolt head lightly touches the bottom of the throttle pedal.
- Tighten the locknut securely.

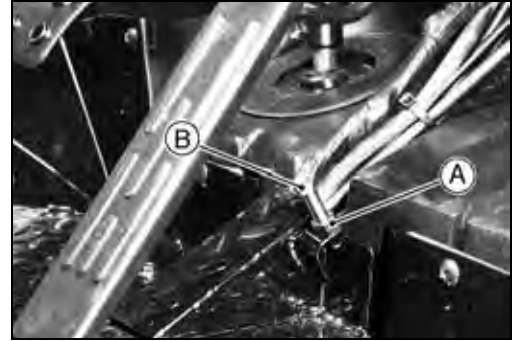

#### Idle Speed Inspection

- Start the engine and warm it up thoroughly.
- Tilt up the cargo bed.
- Check the idle speed with a tachometer.
- ★ If the idle speed is out of the specified range, adjust it.

#### Idle Speed

Standard: 850 ~ 950 r/min (rpm)

#### Idle Speed Adjustment

- Start the engine and warm it up thoroughly.
- Tilt up the cargo bed.
- Loosen the accel lever stopper screw [A] on the control panel.
- Turn the idle adjusting screw [B] at the carburetor until the idle speed is correct.
- Depress and release the throttle pedal a few times to make sure that the idle speed is within the specified range. Readjust if necessary.
- After the adjustment, screw in the accel lever stopper screw [A] until the screw lightly touches the accel lever [C].



#### Fuel System Cleanliness Inspection

#### **⚠ WARNING**

**Gasoline is extremely flammable and can be explosive under certain conditions. Turn the ignition switch OFF. Do not smoke. Make sure the area is well-ventilated and free from any source of flame or sparks; this includes any appliance with a pilot light.**

- Remove:
  - Cargo Bed (tilt up)
- Place a suitable container under the carburetor.
- Turn out the drain screw [A] a few turns to drain some fuel from the carburetor, and check for water or dirt in the fuel.
- ★ If any water or dirt comes out, clean the carburetor and fuel tank (see Fuel Tank) and check the fuel filter.
- Tighten the drain screw securely.

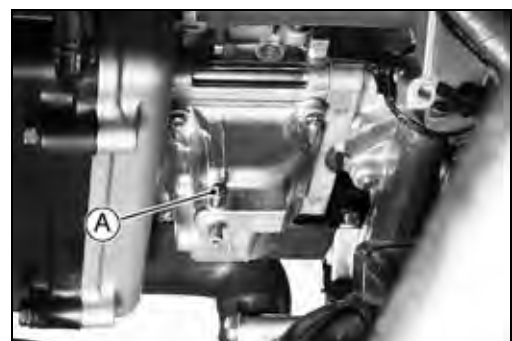

**Periodic Maintenance Procedures**

*Fuel Filter Inspection*

- Visually inspect the fuel filter [A].
- ★ If the filter is clear with no signs of dirt or other contamination, it is OK and need not be replaced.
- ★ If the filter is dark or looks dirty, replace it. Also, check the rest of the fuel system for contamination.

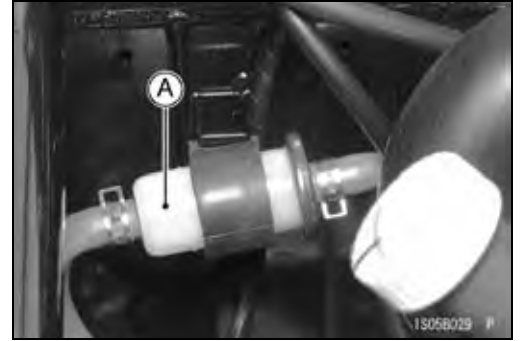

*Intake Chamber Water Draining*

- Lift the cargo bed to support it with the rod.
- Remove the clamp then the drain hose [A] on the intake chamber [B] to expel dust and/or water accumulated inside.

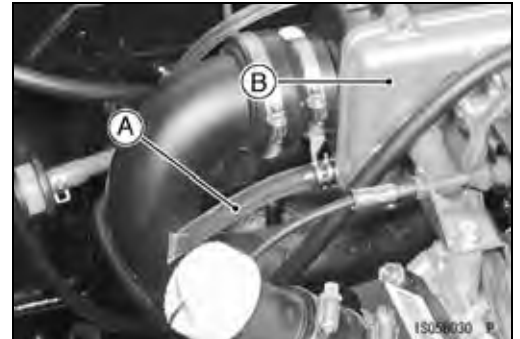

*External Carburetor Mechanism Cleaning*

- Lift the cargo bed to support it with the rod.
- Remove the carburetor cover.
- Clean and lubricate the throttle lever roller [A] and choke lever cam [B], with a penetrating rust inhibitor, such as WD40 or BEL-RAY 6 in 1.
- [C] Throttle Valve Lever

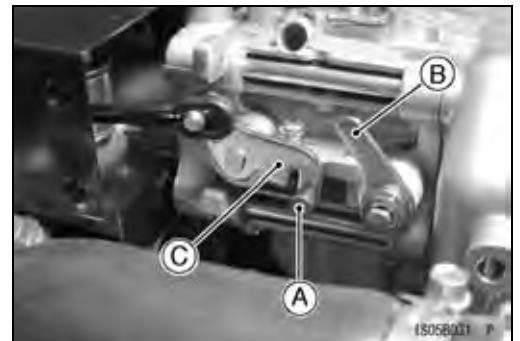

*Fuel Hoses And Connections Inspection*

- Lift up the cargo bed and seat.
- Check the fuel hoses and fittings for deterioration, cracks and signs of leakage.
- ★ Replace the fuel hose if any fraying, leak [A], cracks [B] or bulges [C] are noticed.
- Check that the hoses are securely connected and clamps are installed correctly.
- When installing, route the hoses according to Cable, Wire, and Hose Routing section in the Appendix chapter.
- When installing the fuel hoses, avoid sharp bending, kinking, flattening or twisting, and route the fuel hoses with a minimum of bending so that the fuel flow will not be obstructed.
- ★ Replace the hose if it has been sharply bent or kinked.

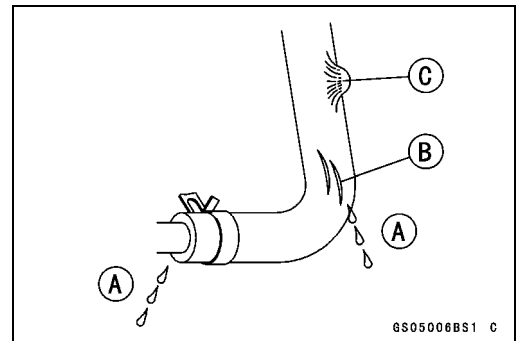

## 2-14 PERIODIC MAINTENANCE

### Periodic Maintenance Procedures

#### Fuel Hoses Replacement

- Tilt up the cargo bed.
- Slide out the plate clamps [A].
- Remove the hoses [B] (see Exploded View in Fuel System chapter).
- When installing, route the hoses according to Cable, Wire, and Hose Routing section in the Appendix chapter.
- When installing the fuel hoses, avoid sharp bending, kinking, flattening or twisting, and route the fuel hoses with a minimum of bending so that the fuel flow will not be obstructed.
- Fit the fuel hose [A] onto the fitting fully and install the plate clamp [B] beyond the raised rib [C].
  - 1 ~ 2 mm (0.0039 ~ 0.0078 in.) [D]
- The hose end must reach the filler [E] or be as near as possible to the step [F].

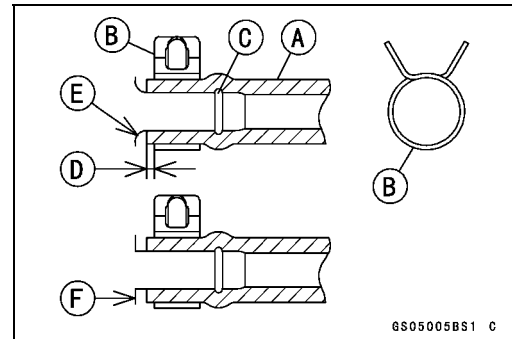
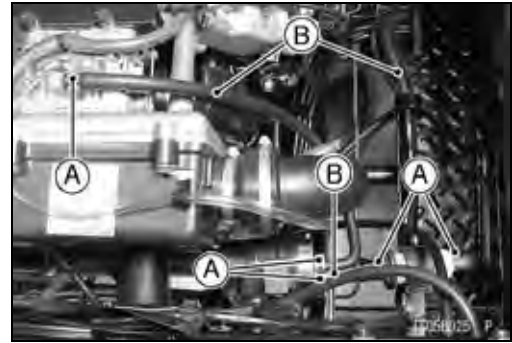

- Bleed the air from the fuel filter (see Next Section).

#### Air Cleaner Element Cleaning

- Unlock the clamps [A].
- Remove:
  - Air Cleaner Cover [B]
- Remove:
  - Element [A]
- Clean the element by tapping gently with the handle end of a screwdriver.
- ★ If the element is very dirty or damaged, replace the element.
- Carefully clean out the air cleaner cover.

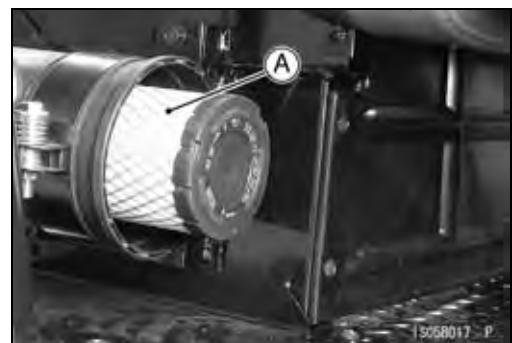
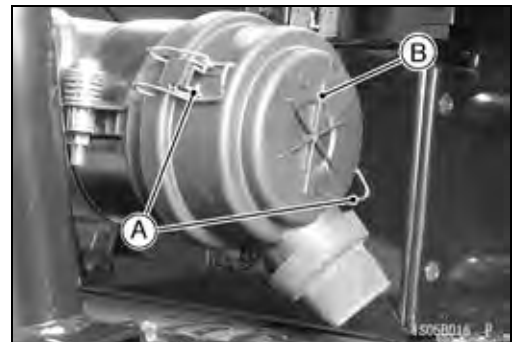

**Periodic Maintenance Procedures**

- Install the cover [A] and lock the clamps.
- Face the TOP mark [B] upward.

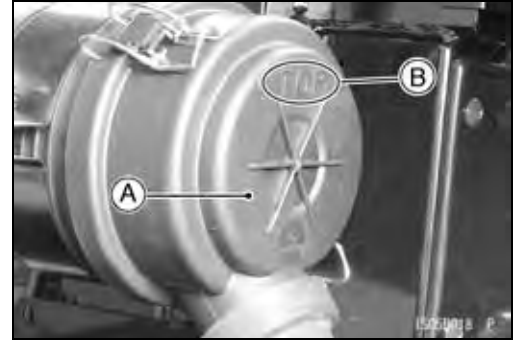

- Reset the Air Filter Restriction Gauge [A] (push [B] its reset button).



*Air Cleaner Housing Dust and/or Water Inspection*

- Push open the drain tube [A] on the bottom of the air cleaner housing.



**Cooling System**

*Radiator Cleaning*

<b>CAUTION</b>
<p><b>Clean the radiator screen and the radiator in accordance with the Periodic Maintenance Chart. In dusty areas, they should be cleaned more frequently than the recommended interval. After riding through muddy terrains, the radiator screen and the radiator should be cleaned immediately.</b></p>

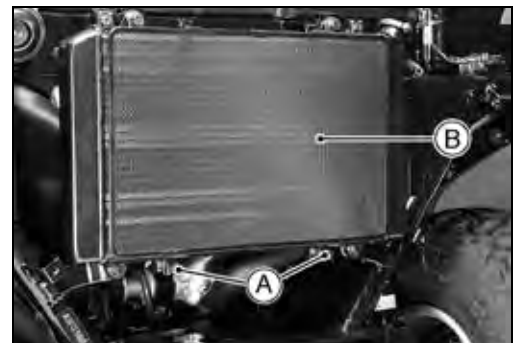

- Remove:
  - Front Fender Front Cover
  - Radiator Screen Mounting Bolts [A]
  - Radiator Screen [B]
- Clean the radiator screen in a bath of tap water, and then dry it with compressed air or by shaking it.

## 2-16 PERIODIC MAINTENANCE

### Periodic Maintenance Procedures

#### CAUTION

When cleaning the radiator with steam cleaner, be careful of the following to prevent radiator damage. Keep the steam gun [A] away more than 0.5 m (1.6 ft) [B] from the radiator core. Hold the steam gun perpendicular to the core surface. Run the steam gun following the core fin direction.

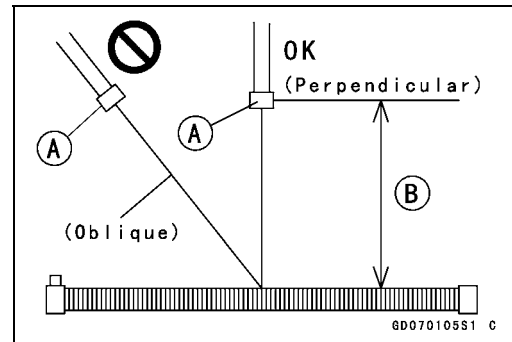

#### Radiator Hose and Connection Inspection

- The high pressure inside the radiator hose can cause coolant to leak or the hose to burst if the line is not properly maintained. Visually inspect the hoses [A] for signs of deterioration. Squeeze the hoses. A hose should not be hard and brittle, nor should it be soft or swollen.
- ★ Replace the hose if any fraying, cracks or bulges are noticed.
- Check that the hoses are securely connected and clamps are tightened correctly.



#### Coolant Draining

#### ⚠ WARNING

To avoid burns, do not remove the radiator cap or try to change the coolant when the engine is still hot. Wait until it cools down. Coolant on tires will make them slippery and can cause an accident and injury. Immediately wash away any coolant that spills on the frame, engine, or wheels. Since coolant is harmful to the human body, do not use for drinking.

- Pull off the reservoir tank hose [A] and pour the coolant into a container.
- Remove:
  - Radiator Cap [B]
- Remove the radiator cap in two steps. First turn the cap counterclockwise to the first stop. Then push and turn it further in the same direction and remove the cap.
- Remove:
  - Coolant Drain Plug [A] at Front Cylinder
- Place a container under the drain plug.

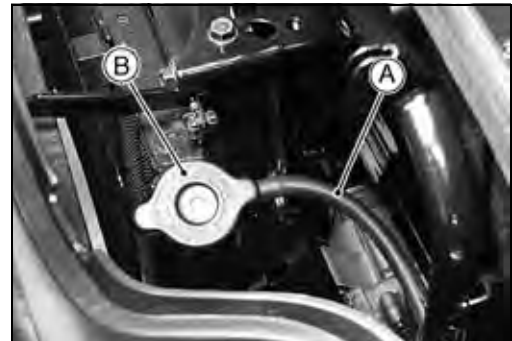

**Periodic Maintenance Procedures**

- Remove:
  - Torque Converter
  - Coolant Drain Plug [A] at Rear Cylinder
- Place a container under the drain plug.

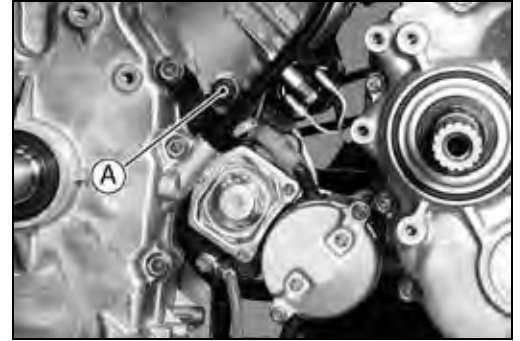

- Remove:
  - Front Final Gear Case Skid Plate
  - Coolant Drain Plugs [A] at Water Pipes
- Place a container under the drain plugs.



*Coolant Filling*

- Tighten the drain plugs.
  - Torque - Coolant Drain Plugs (Cylinder): 17 N·m (1.7 kgf·m, 12 ft·lb)**
- Remove:
  - Radiator Cap
  - Air Bleeder Bolts [A]
- Pour the coolant slowly so that the air in the engine and radiator can escape.



**NOTE**

○ Pour in the coolant slowly so that the air in the engine and radiator can escape.

**CAUTION**

**Soft or distilled water must be used with antifreeze (see Specifications in this chapter) in the cooling system.**  
**If hard water is used in the system, it causes scale accumulation in the water passages, considerably reducing the efficiency of the cooling system.**

**Water and Coolant Mixture Ratio (Recommended)**

Soft Water	:	50%
Coolant	:	50%
Freezing Point	:	-35°C (-31°F)
Total Amount	:	4.6 L (4.9 US qt)

**NOTE**

○ Choose a suitable mixture ratio by referring to the coolant manufacture's directions.

- When the coolant begins to flow out the air bleeder bolt holes, tighten the air bleeder bolts.

## 2-18 PERIODIC MAINTENANCE

### Periodic Maintenance Procedures

- Fill the cooling system up to the filler neck [A] in the radiator cap fitting with coolant.
- Install the radiator cap.
- Fill the reservoir tank up to the F (Full) mark with coolant.



- Bleed the air from the cooling system as follows.
  - Start the engine and run it until no more air bubbles can be seen in the coolant in the reservoir tank (less than five minutes).
  - Tap the radiator hoses to force any air bubbles caught inside.
  - Stop the engine and fill the reservoir tank up to the F (Full) mark with coolant.

#### CAUTION

**Do not add more coolant above the F (Full) mark.**

- Install the reservoir tank cap.

#### Coolant Filter Inspection

- Visually inspect the coolant filter [A].
- ★ If the filter is cleaner with no signs of dirt or other contamination, it is OK and need not be replaced.
- ★ If the filter is dark or looks dirty, replace it. Also, check the rest of the cooling system for contamination.



### Converter System

#### Drive Belt Inspection

- Measure the width [A] of the belt.
- ★ If any measurements exceed the service limit, replace the belt.

#### Belt Width

Standard:	30.3 mm (1.19 in.)
Service Limit:	28.8 mm (1.13 in.)

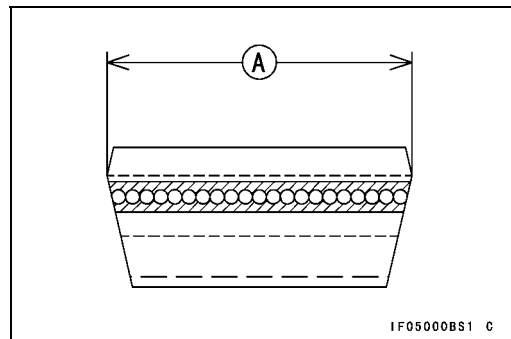



**Periodic Maintenance Procedures**

- Check the belt for wear, cracks, breaks or peeling.
- ★ If necessary, replace the belt with a new one.
  - Belt [A]
  - Crack [B]
  - Broken [C]

**NOTE**

○ Whenever the belt is replaced, inspect the drive and the driven pulleys.

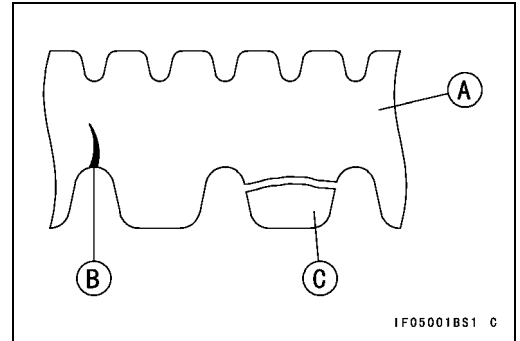

*Converter Driven Pulley Shoe Inspection*

- Remove the driven pulley (see Drive and Driven Pulley Removal in the Converter System chapter).
- Disassembly the driven pulley.
- ★ If the ramps [A] or the wear shoes [B] are damaged or worn, replace the ramp or the shoes.

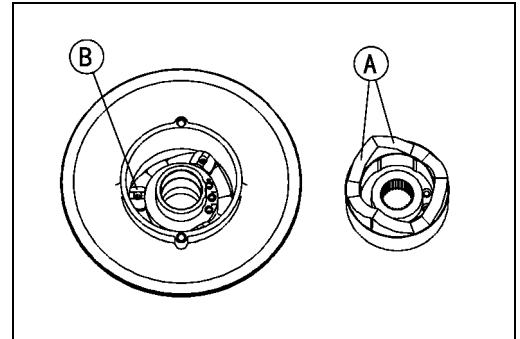

- ★ If the wear shoe contact area width [A] is greater than the service limit, replace the shoe [B].

**Wear Shoe Width**

**Service Limit: 16.3 mm (0.64 in.)**

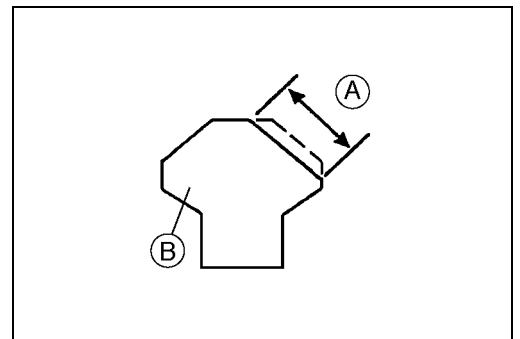

*Air Cleaner Element Cleaning/Inspection*

**NOTE**

- In dusty areas, the element should be cleaned more frequently than the recommended interval.
- After riding through rain or on muddy roads, the element should be cleaned immediately.

**⚠ WARNING**

Clean the element in a well-ventilated area, and take ample care that there are no sparks or flame anywhere near the working area. Because of the danger of highly flammable liquids, do not use gasoline or a low flash-point solvent to clean element.

## 2-20 PERIODIC MAINTENANCE

### Periodic Maintenance Procedures

- Remove the air cleaner element, and separate the foam element [A] from the paper element [B].
- Clean the foam element in a bath of a high flash-point solvent, and then dry it with compressed air or by shaking it.

#### CAUTION

**Do not use compressed air to clean the paper element.**  
**Do not oil the paper element.**

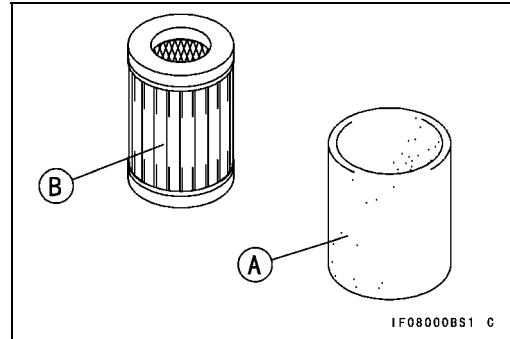

#### Converter Dust or Water Draining

- Unscrew the clamp screw [A] and remove the drain hose [B] on the bottom of the converter housing to expel dust and/or water accumulated inside.

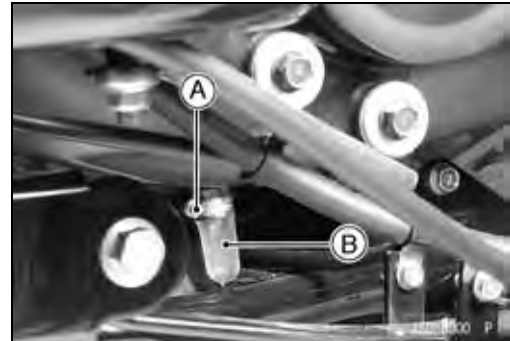

### Engine Top End

#### Valve Clearance Inspection

#### NOTE

○ Valve clearance must be checked when the engine is cold (at room temperature).

- Remove:
  - Alternator Cover [A]
  
- Remove:
  - Cylinder Head Covers [A]
  - Spark Plugs



**Periodic Maintenance Procedures**

- Turn the alternator rotor clockwise so that the mark "1" [A] or "2" [B] on the rotor aligns with the mark [C] on the crankcase breather cover. Check both rocker arms are free. If not, turn the rotor more one turn and free both rocker arms.

**NOTE**

○ The mark "1" is for the No. 1 cylinder, and "2" is for the No. 2 cylinder.

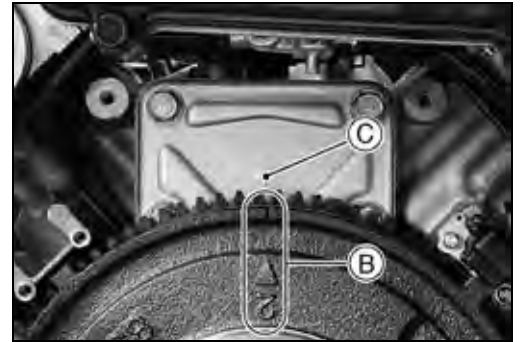
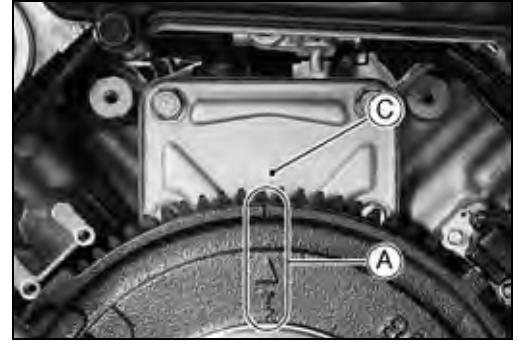

- Using a thickness gauge [A], measure the valve clearance between the rocker arm and the valve stem.
- ★ If the valve clearance is incorrect, adjust it.

**Valve Clearance (when cold)**

**Standard: 0.25 mm (0.010 in.)**



*Valve Clearance Adjustment*

- Loosen the valve adjusting screw locknut [A].
- Turn the valve adjusting screw [B] until the correct clearance is obtained.
- Holding the adjusting screw with the holder [C], tighten the locknut.

**Special Tool - Valve Adjusting Screw Holder: 57001-1217**

**Torque - Valve Adjusting Screw Locknut: 9.8 N·m (1.0 kgf·m, 87 in·lb)**

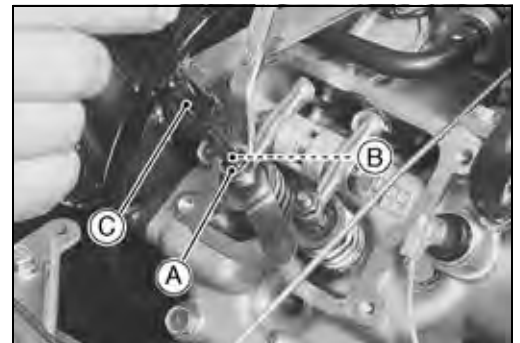

## 2-22 PERIODIC MAINTENANCE

### Periodic Maintenance Procedures

#### Spark Arrester Cleaning

#### **⚠ WARNING**

To avoid burns, wear gloves while cleaning the spark arrester. Since the engine must be run during this procedure, the muffler will become hot.

- Remove the drain plug [A] from the muffler [B].
- Apply the parking brake.
- In an open area away from combustible materials, start the engine with the gear shift lever in the N (neutral) position.
- Raise and lower engine speed while tapping on the muffler with a rubber mallet until the carbon particles are purged from the muffler.

#### **⚠ WARNING**

Do not run the engine in a closed area. Exhaust gases contain carbon monoxide; a colorless, odorless, poisonous gas. Breathing exhaust gas can lead to carbon monoxide poisoning, asphyxiation, and death.

- Stop the engine.
- Install the drain plug.

#### Engine Lubrication

##### Oil and/or Filter Change

- Warm up the engine so that the oil will pick up any sediment and drain easily.
- Place an oil pan beneath the engine.
- Remove the engine oil drain plug [A], and let the oil drain completely.
- ★ If the oil filter is to be changed, replace it with a new one.
- Check the gasket at the drain plug for damage.
- ★ Replace the gasket with a new one if it is damaged.
- After the oil has completely drained out, install the drain plug with the gasket.

**Torque - Engine Oil Drain Plug: 22 N·m (2.2 kgf·m, 16 ft·lb)**

- Fill the engine with a good quality motor oil as specified in the table.
- Check the oil level.

##### Engine Oil

Grade:	API SF or SG API SH or SJ with JASO MA
Viscosity:	SAE 10W-40
Capacity:	1.5 L (1.6 US qt) (when filter is not removed) 1.8 L (1.9 US qt) (when filter is removed)
Oil level:	Between F and L lines on dipstick

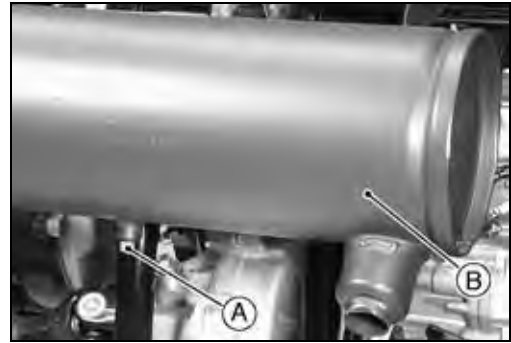

Periodic Maintenance Procedures

**NOTE**

○ Depending on the atmospheric temperature of your riding area, the engine oil viscosity should be changed according to the chart:

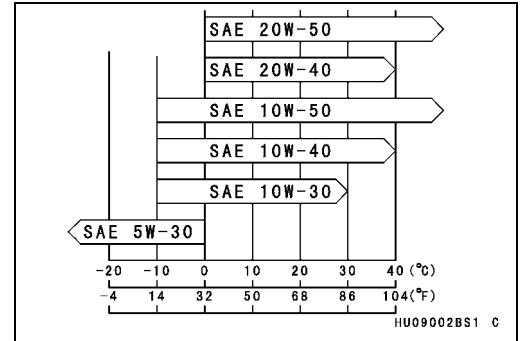

*Oil Filter Removal*

- Tilt up the cargo bed.
- Remove the oil filter [A].
- When unscrewing the oil filter, cover the filter bottom with a clean cloth so as not to spill the engine oil out of the filter. Any split oil should be wiped up completely.



○ Use the oil filter wrench [A] if the oil filter is tight.

**Special Tool - Oil Filter Wrench: 57001-1249**

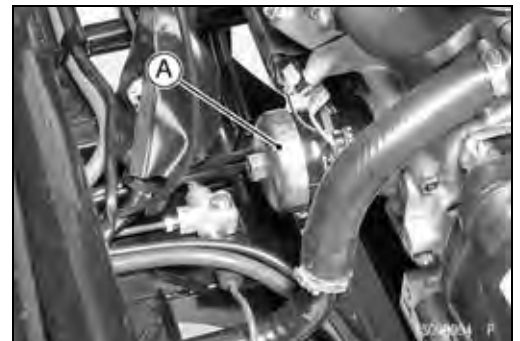

*Oil Filter Installation*

- Apply engine oil:
  - Oil Filter Gasket
- Install the new filter.
- Screw the filter in until the gasket touches the engine, then turn it 3/4 turn.
- Add the engine oil (see Oil Level Inspection).
- Thoroughly warm up the engine, and check the oil leakage and the oil level.
- ★ If necessary, add more engine oil.

## 2-24 PERIODIC MAINTENANCE

### Periodic Maintenance Procedures

#### Transmission

##### *Transmission Oil Change*

- Warm up the oil by running the vehicle so that the oil will pick up any sediment and drain easily. Then stop the vehicle.
- Place an oil pan beneath the transmission case.
- Remove the transmission oil drain plug [A], and let the oil drain completely.
- Check the gasket at the drain plug for damage.
- ★ Replace the gasket with a new one if it is damaged.
- After the oil has completely drained out, install the drain plug with the gasket.

**Torque - Transmission Oil Drain Plug: 15 N·m (1.5 kgf·m, 11 ft·lb)**

- Fill the transmission case with a good quality oil as specified in the table.
- Check the oil level.

##### Transmission Oil

**Type:** API "GL-5" Hypoid gear oil

**Viscosity:** SAE 90: above 5°C (41°F)

SAE 80: below 5°C (41°F)

**Capacity:** 2.5 L (2.6 US qt)

**Oil Level:** Between H and L lines on dipstick



#### Wheels/Tires

##### *Wheels Nuts Tightness Inspection*

- Check the tightness of all the wheel nuts.
- ★ If there are loose nut, first loosen by 1/2 turn, then re-torque them to the specified torque.

**Torque - Wheel Nuts: 137 N·m (14 kgf·m, 101 ft·lb)**

- Tighten the wheel nuts [1] ~ [4] in a criss-cross pattern.



**Periodic Maintenance Procedures**

*Tire Inspection*

- Examine the tire for damage and wear.
- ★ If the tire is cut or cracked, replace it.
- Lumps or high spots on the tread or sidewalls indicate internal damage, requiring tire replacement.
- Remove any foreign objects from the tread. After removal, check for leaks with a soap and water solution.
- Measure the tread depth at the center of the tread with a depth gauge [A]. Since the tire may wear unevenly, take measurements at several places.
- ★ If any of the measurements is less than the service limit, replace the tire.

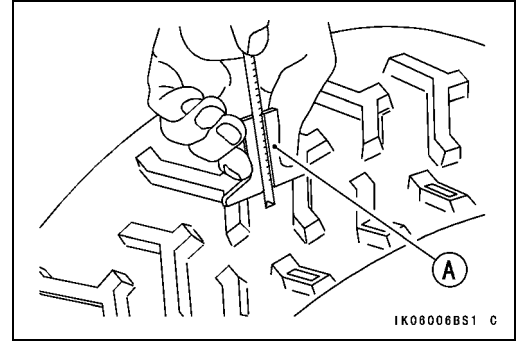

**Tire Tread Depth**

- Standard:** 13.2 mm (0.520 in.)
- Service Limit** 3 mm (0.12 in.)

**Standard Tire**

- Front and rear:** 23 x 11.00-10 DUNLOP KT869 Tubeless

**Final Drive**

*Front Final Gear Case Oil Change*

- Warm up the oil by running the vehicle so that the oil will pick up any sediment and drain easily. Then stop the vehicle.
- Park the vehicle so that it is level, both side-to-side and front-to-rear.
- Remove:
  - Front Final Gear Case Skid Plate
- Place an oil pan beneath the front final gear case and remove the drain plug [A].

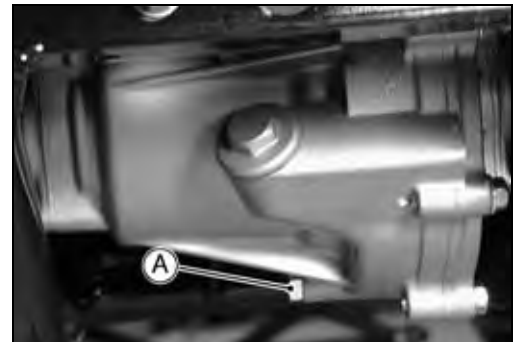

**⚠ WARNING**

**When draining or filling the final gear case, be careful that no oil gets on the tire or rim. Clean off any oil that inadvertently gets on them with a high-flash point solvent.**

- After the oil has completely drained out, install the drain plug with a new aluminum gasket, and tighten it.
  - Torque - Oil Drain Plug: 20 N·m (2.0 kgf·m, 14 ft·lb)**
- Fill the gear case up to the bottom of filler opening with the oil specified below.

**Front Final Gear Case Oil**

- Type:** API "GL-5 or GL-6" hypoid gear oil for LSD (Limited Slip Differential gears)
- Viscosity:** SAE 85W-140, SAE 90, or SAE 140
- Capacity:** 0.4 L (0.4 US qt)
- Oil Level** Filler opening level

**NOTE**

○ "GL-5 and GL-6" indicate a quality and additive rating.

- Be sure the O-ring is in place, and tighten the filler cap.

**Torque - Oil Filler Cap: 29 N·m (3.0 kgf·m, 22 ft·lb)**

## 2-26 PERIODIC MAINTENANCE

### Periodic Maintenance Procedures

#### Brakes

##### *Brake Fluid Level Inspection*

- With the vehicle on level ground, check that, through the inspection hole [A], the fluid level in the reservoir is between the upper (MAX) and lower (MIN) level lines.
- ★ If the fluid level is lower than the lower level line, check for fluid leaks in the brake lines, and fill the reservoir to the upper level line.

#### **⚠ WARNING**

**Change the fluid in the brake system completely if the fluid level is low but the type and brand of the fluid already in the reservoir are unknown.**

- Raise the front cargo hood (see Frame chapter).
- Remove:
  - Rubber Cap [A]

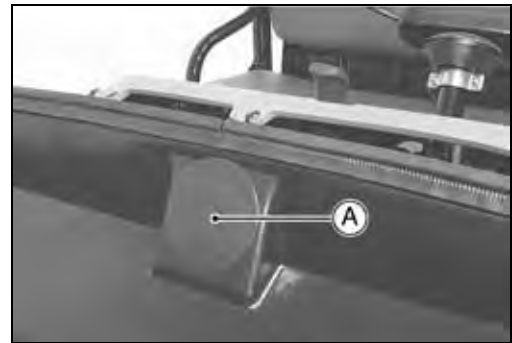
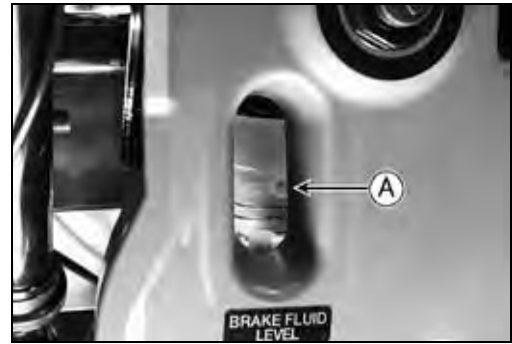

- Fill the reservoir to the upper level line [A].
  - Upper Level Line (MAX)
  - Lower Level Line (MIN) [B]

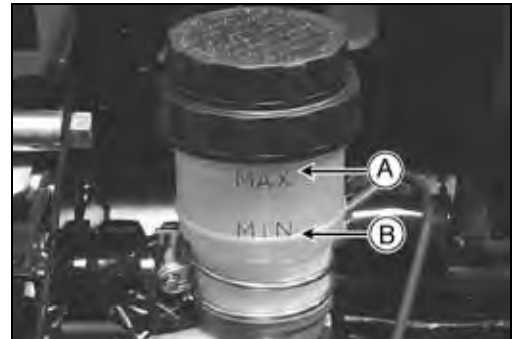

- Apply the brake forcefully for a few seconds and check for fluid leakage around the fittings.

#### **⚠ WARNING**

**If the brake pedal has a soft or "spongy feeling" when it is applied, there might be air in the brake lines or the brake may be defective. Since it is dangerous to operate the vehicle under such conditions, have the brake system serviced immediately.**



## Periodic Maintenance Procedures

### Brake Fluid Changing

- Remove the maintenance cover.
- Check that there is plenty of fluid in the reservoir.

#### NOTE

○ *The fluid level must be checked several times during the fluid changing and replenished as necessary. If the fluid in the reservoir runs completely out any time during fluid changing, air bleeding must be done since air will have entered the line.*

- Remove the wheel for extra clearance.
- Connect a clear plastic hose to the bleed valve at the wheel cylinder, running the other end of the hose into a container.

#### NOTE

○ *Start with the rear left or right wheel and finish with the front left or right wheel.*

- Open the bleed valve, apply pressure to the brake pedal, close the valve while the brake is applied, and then quickly release the pedal. Repeat this operation until fresh brake fluid comes out from the plastic hose or the color of the fluid changes.

1. Open bleed valve.
2. Apply brake pedal and hold it.
3. Close bleed valve.
4. Release brake pedal.

- Tighten:

**Torque - Bleed Valves: 5.9 N·m (0.60 kgf·m, 52 in·lb)**

- Repeat the previous step for each wheel.
- When brake fluid changing is finished, add the fluid to the upper level in the reservoir.
- Apply the brake forcefully for a few seconds, and check for fluid leakage around the fittings.

#### **⚠ WARNING**

**If the brake pedal has a soft or "sponge feeling" when it is applied, there might be air in the brake line or the brake may be defective. Since it is dangerous to operate the vehicle under such conditions, bleed the air from the brake line immediately.**

- Install the removed parts.

### Brake Pedal Free Play Adjustment

- Check brake pedal free play [A].

#### Brake Pedal Free Play

**Standard: 2 ~ 10 mm (0.08 ~ 0.39 in.)**

- ★ If free play is not correct, adjust it.

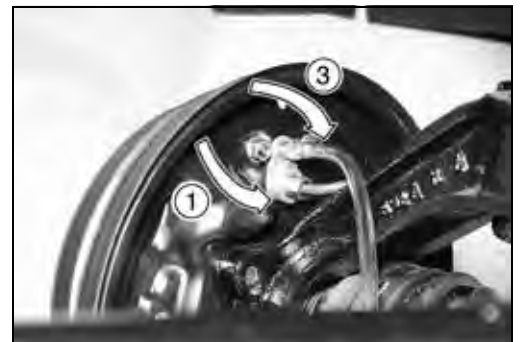

## 2-28 PERIODIC MAINTENANCE

### Periodic Maintenance Procedures

- Loosen the locknut [A] and turn the push rod [B] to obtain the correct amount of free play.
- Tighten:  
**Torque - Push Rod Locknut: 18 N·m (1.8 kgf·m, 13 ft·lb)**
- Check for brake drag and braking effectiveness.

#### **⚠ WARNING**

**Incorrect adjustment with insufficient free play can cause brake heating and drag. Skidding and loss of control may result.**

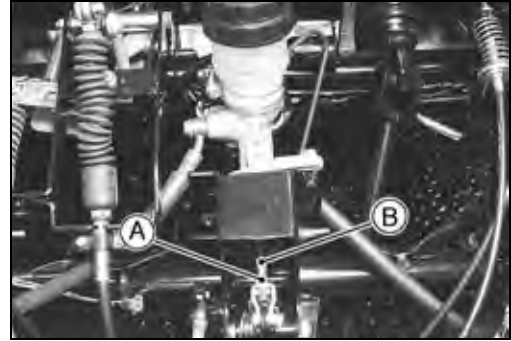

#### *Brake Master Cylinder Cup and Dust Seal Replacement*

- Remove the master cylinder (see Master Cylinder Removal in the Brakes chapter).
- Push the pistons in all the way with a screwdriver and remove the piston stop bolt.
- Remove the retainer with the circlip pliers and remove the pistons.

**Special Tool - Inside Circlip Pliers: 57001-143**

- Remove the pistons by lightly applying compressed air to where the brake pipe fits into the cylinder.

Dust Cover [A]

Retainer [B]

Pistons [C]

Springs [D]

Secondary Cup [E]

Primary Cup [F]

Piston Stop Bolt [G]

Master Cylinder [H]

Be careful of the secondary cup direction [I]

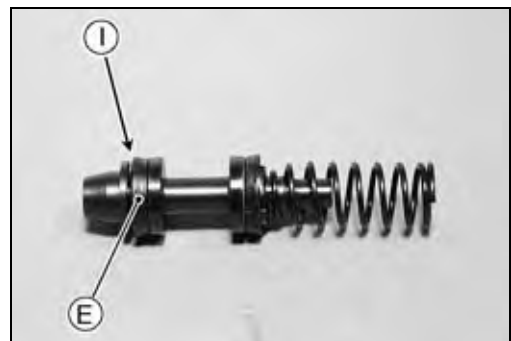
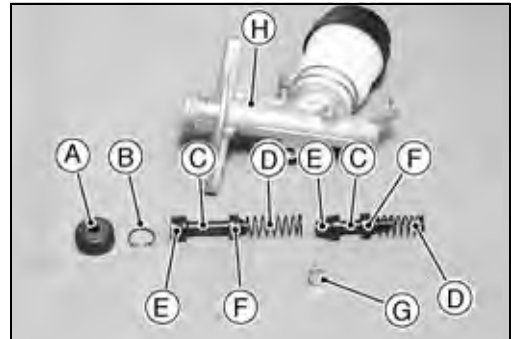

- Before assembly, clean all parts including the master cylinder with brake fluid or alcohol, and apply brake fluid to the removed parts and the inner wall of the cylinder.

#### **CAUTION**

**Use only brake fluid, isopropyl alcohol, or ethyl alcohol, for cleaning brake parts. Do not use any other fluid for cleaning these parts. Gasoline, motor oil, or any other petroleum distillate will cause deterioration of the rubber parts. Oil spilled on any part will be difficult to wash off completely, and will eventually deteriorate the rubber used in the brake.**

- Push the pistons in all the way with a screwdriver and install the piston stop bolt.
- Tighten:  
**Torque - Piston Stop Bolt: 8.8 N·m (0.90 kgf·m, 78 in·lb)**  
**Reservoir Clamp Bolt: 5.9 N·m (0.60 kgf·m, 52 in·lb)**

**Periodic Maintenance Procedures**

*Brake Hose and Pipe Inspection*

- The high pressure inside the brake line can cause fluid to leak or the hose to burst if the line is not properly maintained. Bend and twist the rubber hose while examining it.
- ★ Replace it if any cracks or bulges are noticed.
- The metal pipe will rust if the plating is damaged.
- ★ Replace the pipe if it is rusted, cracked (especially check the fittings), or if the plating is badly scratched.

*Brake Hose and Pipe Replacement*

- To remove the metal pipes [A], unscrew the nipples [B].
- To remove the hoses [C], remove the banjo bolts [D] and/or pull out the retainers [E] (see below).
- Immediately wipe up any brake fluid that spills.

**CAUTION**

**Brake fluid quickly ruins painted surfaces; any spilled fluid should be completely wiped up immediately.**

- Use a new aluminum washer for each side of the hose fittings at the master cylinder.
- Apply brake fluid:  
 Brake Pipe Nipple Threads
- Tighten:
    - Torque - Brake Hose Banjo Bolts: 25 N-m (2.5 kgf-m, 18 ft-lb)**
    - Brake Pipe Nipples: 18 N-m (1.8 kgf-m, 13 ft-lb)**
  - Check that the brake line has proper fluid pressure and no fluid leakage.

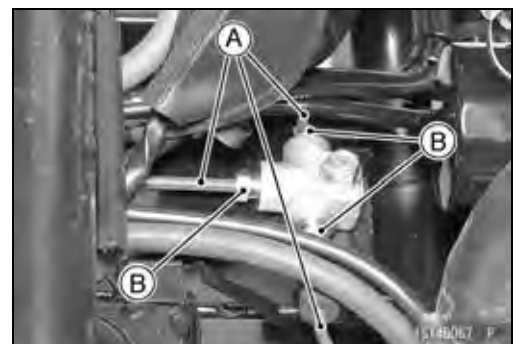
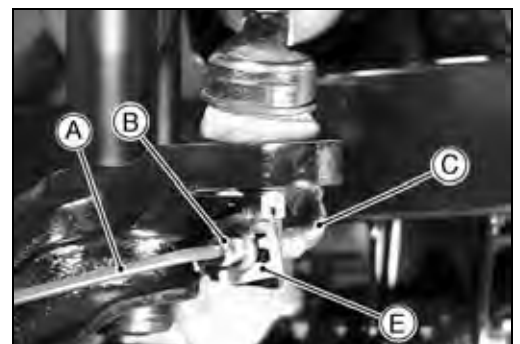
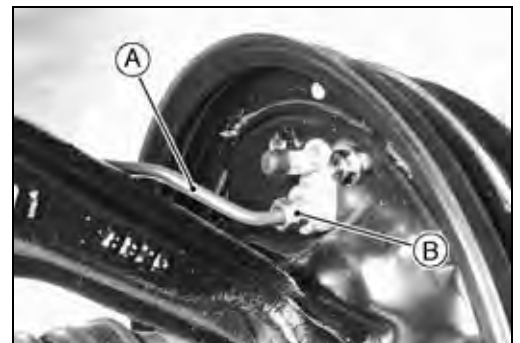
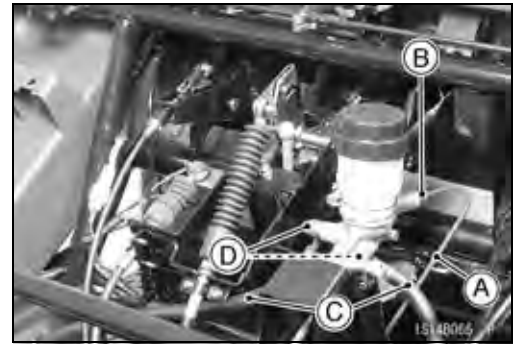

## 2-30 PERIODIC MAINTENANCE

### Periodic Maintenance Procedures

- [A] Metal Pipes
- [B] Nipples
- [C] Hoses
- [E] Retainers

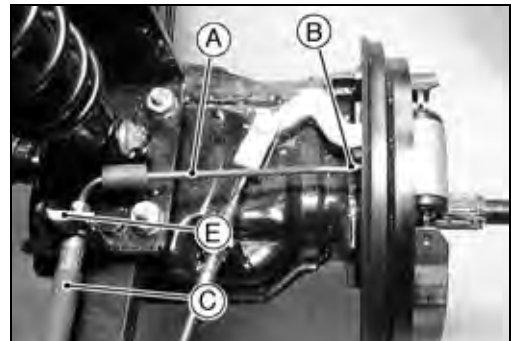
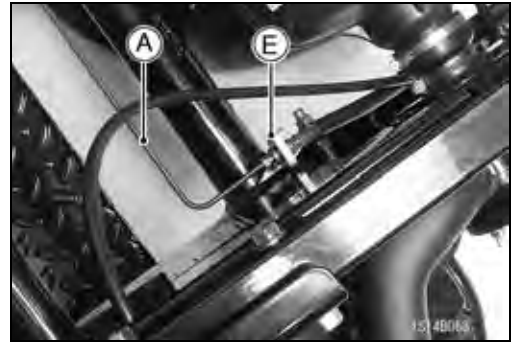

#### *Brake Wear Inspection*

- Remove the brake drum (see Brake Drum Removal in the Brakes chapter).
- Measure the inside diameter of the drum at several points.
- ★ If any measurement is greater than the service limit, replace the drum.
- ★ If the drum is worn unevenly or scored, lightly turn the drum on a brake drum lathe or replace it. Do not turn the drum beyond the service limit.

#### **Brake Drum Inside Diameter**

**Standard:** 180.000 ~ 180.160 mm (7.0866 ~ 7.0929 in.)

**Service Limit:** 180.75 mm (7.116 in.)

- Measure the lining thickness at several points.

#### **Brake Shoe Lining Thickness**

**Standard:** 4.5 mm (0.18 in.)

**Service Limit:** 1.0 mm (0.04 in.)

- ★ If any measurement is less than the service limit, replace both shoes as a set.
- ★ If the lining thickness is greater than the service limit, do the following before installing the shoes.
- File or sand down any high spots on the surface on the lining.
- Use a wire brush to remove any foreign particles from the lining.
- Wash off any oil or grease with an oilless solvent.

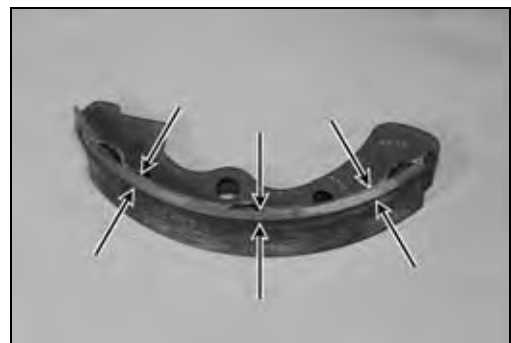

#### **CAUTION**

**Do not use a solvent which will leave on oily residue or the shoes will have to be replaced.**

**Periodic Maintenance Procedures**

*Brake Wheel Cylinder Assembly Replacement*

- Remove:
  - Brake Drum (see Brake Drum Removal)
  - Brake Pipe Nipple [A]
- Immediately wipe up any brake fluid that spills.

**CAUTION**

**Brake fluid quickly ruins painted surfaces; any spilled fluid should be completely wiped up immediately.**

- ★ Loosen the brake wheel cylinder mounting bolts [B] for cylinder removal.

- Remove:
  - Brake Shoe Spring [A]
  - Brake Shoe [B]
- Push the shoe hold-down springs [C] and twist the pins [D] to remove the shoes.

**NOTE**

- Hold the brake shoes with a clean cloth to protect the linings from grease or dirt.

- Remove the collar [E] on the rear brake panel.

- Replace the rear wheel cylinder with a new one.
  - Set the brake shoe clearance adjuster so that the drum can be reinstalled on the panel assembly.
- (Front Brake Panel)
- Turn one of the wheel cylinder ends [A] while pushing it in. Keep the other end [B] from turning until both the ends of the pistons are back in the cylinder completely.

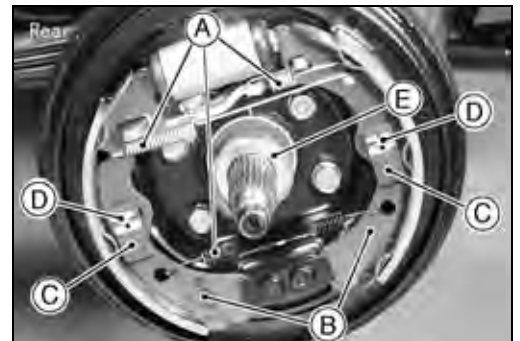
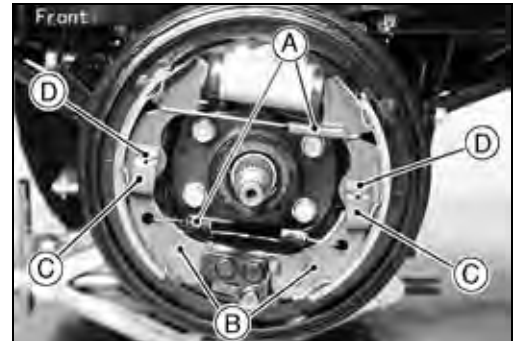
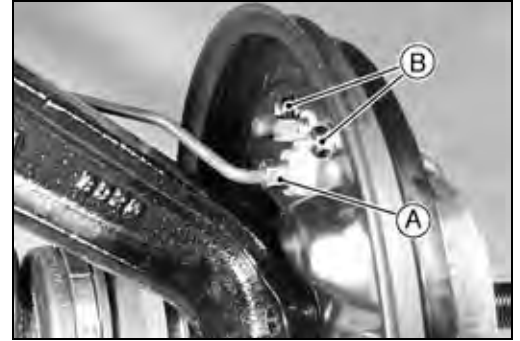

## 2-32 PERIODIC MAINTENANCE

### Periodic Maintenance Procedures

(Rear Brake Panel)

- Pry the ratchet lever [A] with a screwdriver [B] to reset the shoe clearance adjuster in its original position [C]

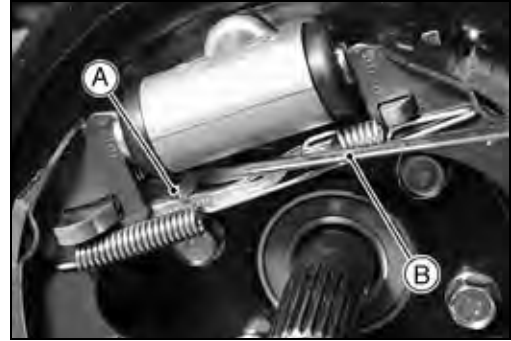

- Grease (Amoco Rykon Premium Grease No. 2 EP Green):
  - Brake Panel Seating Surface
- Apply a non-permanent locking agent:
  - Brake Panel Mounting Bolts
- Apply brake fluid:
  - Brake Pipe Nipple Threads
- Tighten:

**Torque - Wheel Cylinder Mounting Bolts: 11 N·m (1.1 kgf·m, 95 in·lb)**

**Wheel Cylinder Mounting Nuts: 7.8 N·m (0.80 kgf·m, 69 in·lb)**

**Brake Panel Mounting Bolts: 44 N·m (4.5 kgf·m, 33 ft·lb)**

**Brake Pipe Nipple: 18 N·m (1.8 kgf·m, 13 ft·lb)**

- Grease [A]:
  - Brake Panel and Brake Shoe Contact Points
  - Wheel Cylinder Piston Ends
  - Brake Shoe Anchor Ends
- Grease (rear brake only) [B]:
  - Shoe Clearance Adjuster Pivots
  - Shoe Clearance Adjuster and Shoe Contact Points

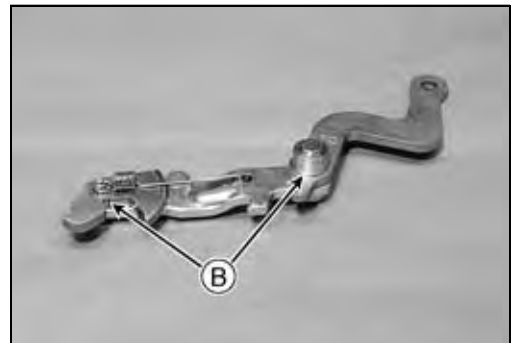

**Periodic Maintenance Procedures**

*Parking Brake Lever Travel Adjustment*

- Check parking brake lever travel [A].
- Pull the parking brake lever [B] upward slowly all way. Count the number of notches (clicks) during lever travel.
- ★ If lever travel is not correct, adjust it.

**Parking Brake Lever Travel**

**Standard: 8 ~ 12 notches (clicks) at 200 N (20 kg, 44 lb)**

- Release the parking brake and return the lever to its rest position.
- Loosen the locknut [A] and turn the adjusting nut [B] to obtain the correct amount of lever travel.
- Tighten the locknut.
- Check for brake drag and braking effectiveness.

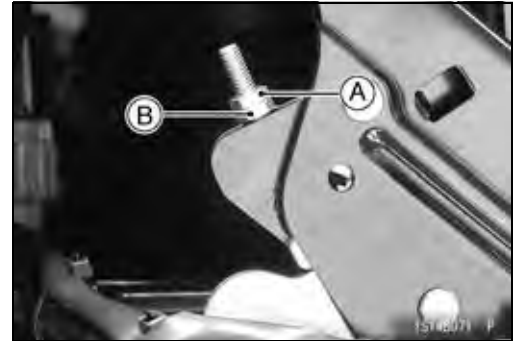
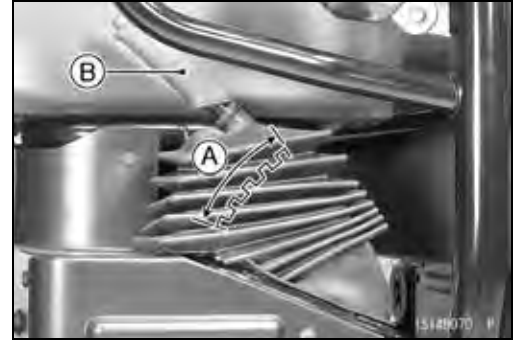

**⚠ WARNING**

**Incorrect adjustment with insufficient free play can cause brakes to overheat and drag. Skidding and loss of control may result.**

**NOTE**

- If the parking brake lever travel cannot be adjusted by using the adjusting nut at the lever, use the adjusters [A] at the parking brake lever and rear wheels. Do not forget to adjust both the left and right cables evenly, and then securely tighten the adjuster mounting nuts [B].

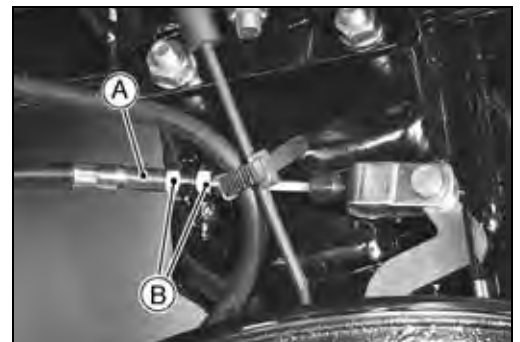

## 2-34 PERIODIC MAINTENANCE

### Periodic Maintenance Procedures

#### Steering

##### *Steering Wheel Free Play Inspection*

- Check steering wheel free play [A].
- Set the front wheels straight ahead. Gently turn [B] the steering wheel left and right. The steering wheel free play is the amount of travel in the steering wheel, before the front wheels begin to turn.

##### **Steering Wheel Free Play**

**Standard:** 0 ~ 20 mm (0 ~ 0.79 in.)

- ★ If steering wheel free play is not correct, inspect the following:
  - Steering Wheel Mounting Nut (see Steering chapter)
  - Intermediate Shaft Clamp Bolts (see Steering chapter)
  - Steering Gear Assembly Mounting Bracket Bolts (see Steering chapter)
  - Steering Gear Assembly Mounting Rubber Dampers
  - Tie-rod End Nuts (see Wheels/Tires chapter)
  - Steering Gear Preload Adjustment (see Steering chapter)
- ★ If the inspections above check out good but the free play is out of the specified, the steering gear assembly is damaged and should be replaced as a unit.

##### *Steering Joint Dust Boot Inspection*

- Visually inspect the dust boots [A] at both the ends of the steering gear assembly.
- Front [B]
- ★ If there is any signs of deterioration, cracks, or damage, replace the steering gear assembly together with these boots.

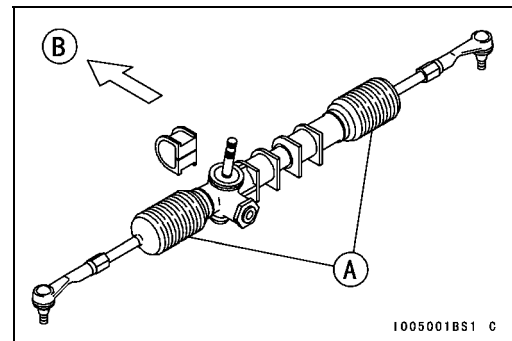
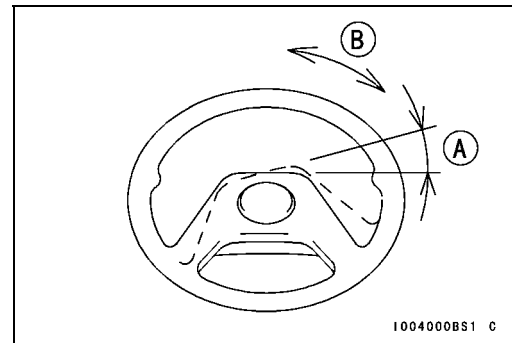

#### Frame

##### *Seat Belt Inspection*

- Check that each seat belt functions properly.
- Push the latch plate [A] into the buckle [B] until it clicks the latch plate must slide smoothly into the buckle, the click sound shows it is securely latched.
- Push the red button [C] in the buckle to make sure it release freely.
- Check the belt webbing for wear, cuts or damage.
- ★ If any irregularities are found, replace the seat belt.

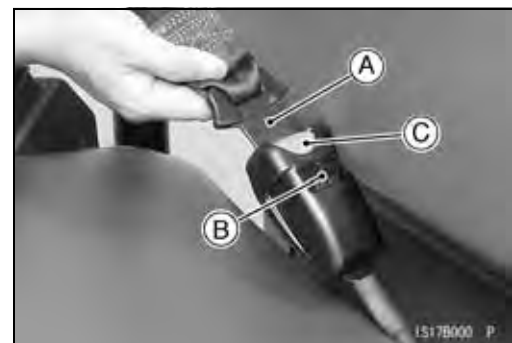



**Periodic Maintenance Procedures**

**Electrical System**

*Brake Light Switch Adjustment*

- Check the operation of the brake light switch by depressing the brake pedal. The brake light should go on after 10 mm (0.4 in.) of pedal travel [A].



- ★ If it does not, adjust the brake light switch [A] up or down. To change the switch position, turn the adjusting nut [B].

**Brake Light Switch Timing**

Standard: ON after 10 mm (0.4 in.) of pedal travel

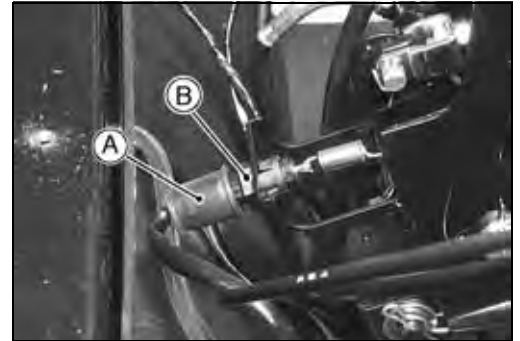

**CAUTION**

To avoid damaging the electrical connections inside the switch, be sure that the switch body does not turn during adjustment.

*Spark Plug Cleaning/Inspection*

- Remove the spark plug (see Electrical System chapter).
- Clean the spark plug, preferably in a sandblasting device, and then clean off any abrasive particles. The plug may also be cleaned using a wire brush or other suitable tool.
- ★ If the spark plug electrodes are corroded or damaged, or if the insulator is cracked, replace the plug. Use the standard spark plug or its equivalent.

*Spark Plug Gap Inspection*

- Measure the gap [A] with a wire-type thickness gauge.
- ★ If the gap is incorrect, carefully bend the side electrode [B] with a suitable tool to obtain the correct gap.

**Spark Plug Gap**

Standard: 0.7 ~ 0.8 mm (0.028 ~ 0.031 in.)

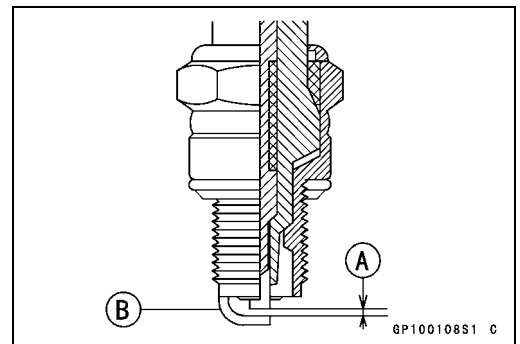

**General Lubrication**

- Before lubricating each part, clean off any rusty spots with rust remover and wipe off any grease, oil, dirt, or grime.
- Lubricate the points listed below with indicated lubricant.

**NOTE**

○ Whenever the vehicle has been operated under wet or rainy conditions, or especially after using a high-pressure spray water, perform the general lubrication.

## 2-36 PERIODIC MAINTENANCE

### Periodic Maintenance Procedures

#### Pivots and Points: Lubricate with Grease.

- Seat Brackets
- Cargo Bed Mounting Pins
- Throttle Pedal Pivot
- Brake Pedal Pivot
- Transmission Shift Control Lever Pivot
- Differential Shift Cable Upper End
- 2WD/4WD Shift Lever Pivot
- Propeller Shaft Bearing [A] (under seat)
- Grease the propeller shaft bearing using the grease nipple [B].

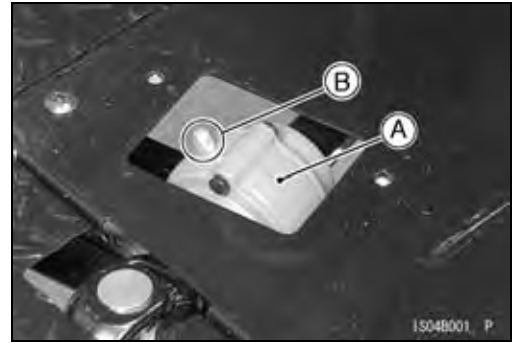

#### Cables: Lubricate with Rust Inhibitor.

- Throttle Cable
- Differential Shift Cable
- 2WD/4WD Shift Cable

#### Cables: Lubricate with Motor Oil.

- Parking Brake Cables

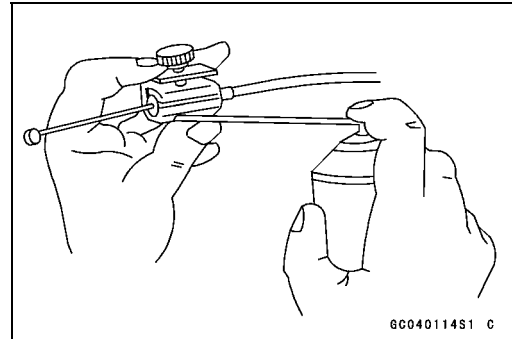

- With the cable disconnect at both ends, the cable should move freely [A] within the cable housing.

- ★ If cable movement is not free after lubricating, if the cable is frayed [B], or if the cable housing is kinked [C], replace the cable.

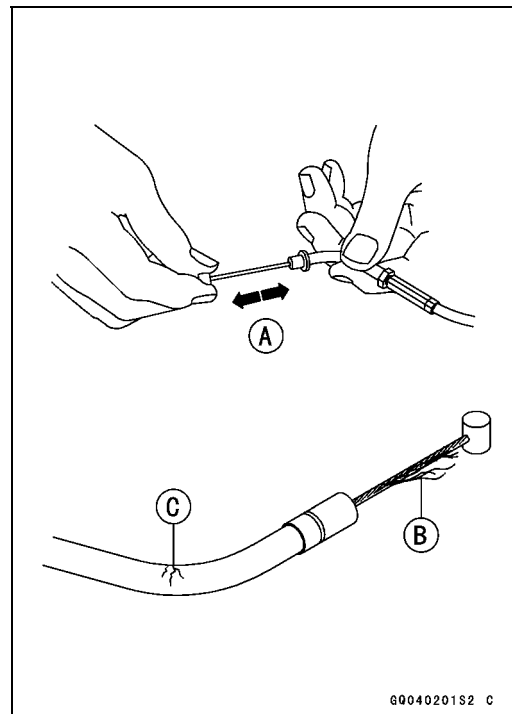

## Periodic Maintenance Procedures

---

### Bolts, Nuts, and Fasteners

#### *Tightness Inspection*

- Check the tightness of the bolts and nuts listed here. Also, check to see that each cotter pin is in place and in good condition.

#### **NOTE**

○ *Check the engine fastener tightness when the engine is cold (at room temperature).*

- ★ If there are loose fasteners, first loosen by 1/2 turn, then retorque them to the specified torque following the specified tightening sequence. Refer to the appropriate chapter for torque specifications. If torque specifications are not in the appropriate chapter, see the basic torque table (see Torque and Locking Agent in this chapter).
- ★ If cotter pins are damaged, replace them with new ones.

### Nut, Bolt, and Fasteners to be checked

#### **Engine:**

Engine Mounting Bolts  
 Exhaust Pipe Holder Nuts  
 Exhaust Pipe and Muffler Clamp Bolt  
 Muffler Mounting Bolts  
 Throttle Pedal Pivot Clip  
 Fuel Tank Holder Nuts

#### **Transmission/Final Drive:**

Axle Nuts and Cotter Pins  
 Drive Shaft Bracket Mounting Nuts  
 Transmission Shift Cable Upper End Clip  
 Transmission Shift Lever Clamp Bolt  
 Differential Shift Lever Pivot Clip  
 Differential Shift Cable Upper End Clip  
 Differential Shift Lever Mounting Nut  
 Propeller Shaft Bearing Mounting Nuts  
 2WD/4WD Shift Lever Pivot Clip  
 2WD/4WD Shift Lever Mounting Nut  
 Hi/Low Shift Lever Pivot Clip  
 Hi/Low Shift Cable Upper End Clip  
 Hi/Low Shift Lever Mounting Nut

#### **Wheels:**

Wheel Nuts

#### **Brakes:**

Master Cylinder Mounting Bolts  
 Master Cylinder Push Rod Clevis Pin Clip  
 Parking Brake Lever Assembly Mounting Bolts  
 Parking Brake Cable Lower End Clevis Pin Cotter Pins  
 Brake Pedal Pivot Shaft Cotter Pin

#### **Suspension:**

Suspension Arm Pivot Bolts  
 Strut Mounting Nuts  
 Strut Clamp Nuts and Cotter Pins  
 Leaf Spring Mounting Nuts  
 Shock Absorber Mounting Nuts

## 2-38 PERIODIC MAINTENANCE

---

### Periodic Maintenance Procedures

---

#### **Steering:**

- Steering Wheel Mounting Nut
- Intermediate Shaft Clamp Bolts
- Tie-rod End Nuts and Cotter Pins
- Tie-rod End Locknuts
- Suspension Arm Joint Nuts and Cotter Pins
- Main Shaft Mounting Bolts and Nuts

#### **Frame:**

- Front and Rear Bar Mounting Bolts and Nuts
- Front Guard Mounting Nuts
- Cargo Bed Hook Mounting Bolts
- Cargo Bed Mounting Pin Clips
- Screen Mounting Nuts
- Seat Bracket Nuts
- Seat Back Mounting Nuts
- Seat Belt Mounting Bolts
- Battery Holder Nuts
- Skid Plate Mounting Bolts
- Rear End Sub-frame Mounting Nuts

# Fuel System

## Table of Contents

Exploded View.....	3-2	Choke Cable Lubrication.....	3-14
Specifications .....	3-6	Choke Cable Inspection.....	3-15
Throttle Pedal and Cable.....	3-7	Carburetor .....	3-16
Throttle Pedal Free Play		Idle Speed Inspection .....	3-16
Inspection.....	3-7	Idle Speed Adjustment.....	3-16
Throttle Pedal Free Play		Fuel System Cleanliness	
Adjustment .....	3-7	Inspection.....	3-16
Full Throttle Pedal Position		Carburetor Removal.....	3-16
Adjustment .....	3-7	Carburetor Installation.....	3-17
Throttle Cable Installation .....	3-7	Carburetor Disassembly .....	3-18
Throttle Cable Lubrication.....	3-7	Carburetor Assembly .....	3-19
Throttle Cable Inspection.....	3-7	Carburetor Cleaning.....	3-20
Governor Link Mechanism.....	3-8	Carburetor Inspection .....	3-20
Control Panel Assembly Removal	3-8	Coolant Filter Cleaning .....	3-21
Control Panel Assembly		Coolant Valve Inspection .....	3-21
Installation .....	3-8	Air Cleaner.....	3-22
Governor Arm and Throttle Link		Air Cleaner Element Cleaning.....	3-22
Removal .....	3-11	Air Cleaner Housing Removal.....	3-22
Governor Arm Installation .....	3-11	Air Cleaner Housing Installation...	3-22
Governor Assembly Removal .....	3-12	Air Cleaner Housing Dust and/or	
Governor Assembly Installation ...	3-12	Water Inspection .....	3-22
Governor Assembly Inspection ....	3-12	Fuel Pump and Fuel Filter .....	3-23
Throttle Link Lever Installation.....	3-13	Fuel Pump and Fuel Filter	
Maximum Engine Speed		Removal.....	3-23
Inspection.....	3-13	Fuel Pump Installation .....	3-23
Choke Cable.....	3-14	Fuel Filter Installation.....	3-23
Choke Cable Free Play		Fuel Filter Inspection.....	3-23
Inspection.....	3-14	Fuel Tank.....	3-24
Choke Cable Free Play		Fuel Tank Removal .....	3-24
Adjustment .....	3-14	Fuel Tank Installation .....	3-25
Choke Cable Installation.....	3-14	Fuel Tank Cleaning/Inspection....	3-25

# 3-2 FUEL SYSTEM

## Exploded View

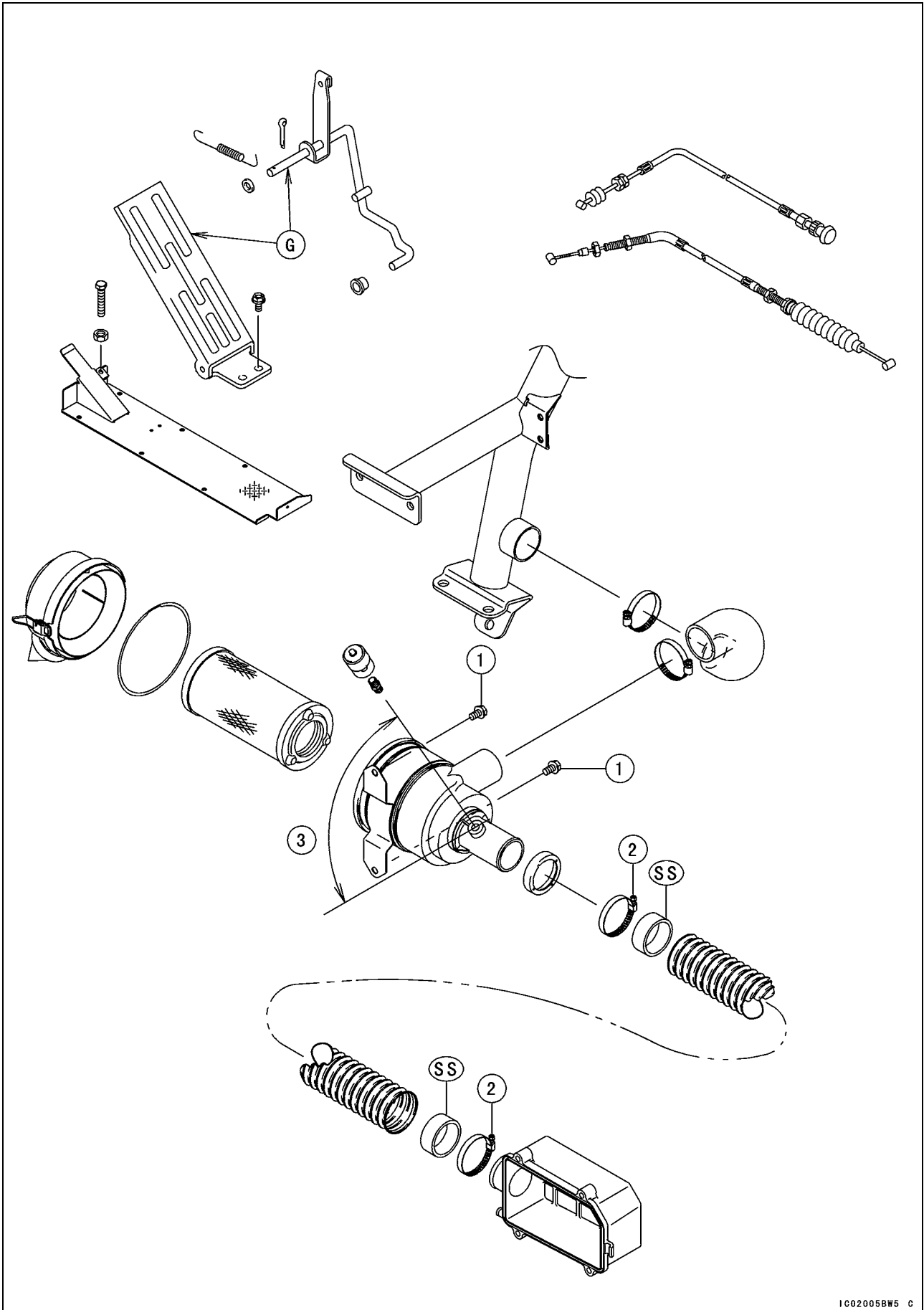

1C02005BW5 C

**Exploded View**

No.	Fastener	Torque			Remarks
		N-m	kgf-m	ft-lb	
1	Air Cleaner Housing Mounting Bolts	20	2.0	14	
2	Air Duct Clamps	0.98	0.10	8.7 in-lb	

3. Approximately 60°

G: Apply grease.

SS: Apply silicone sealant (Kawasaki Bond: 56019-120) around the tubes.

# 3-4 FUEL SYSTEM

## Exploded View

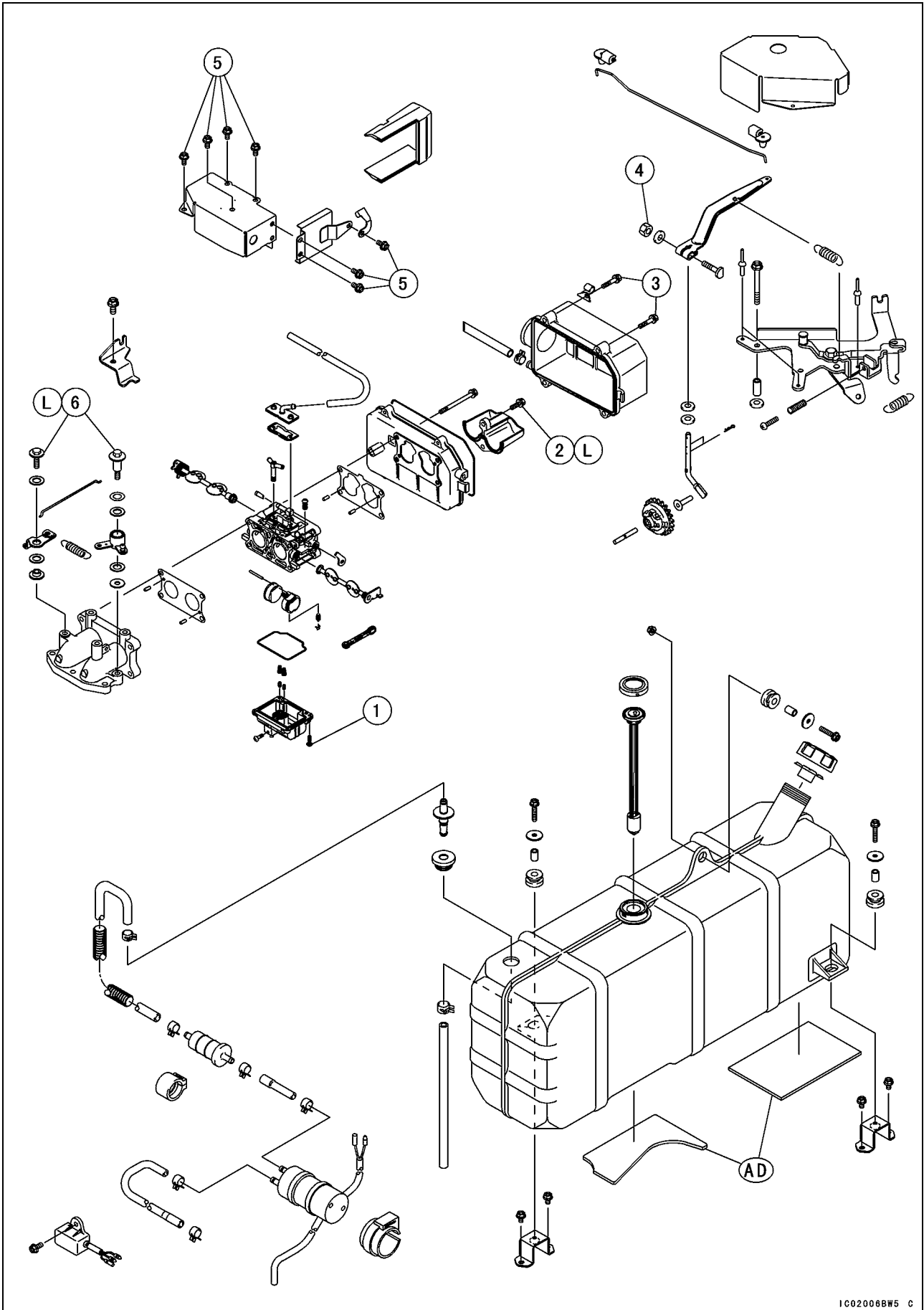



**Exploded View**

No.	Fastener	Torque			Remarks
		N-m	kgf-m	ft-lb	
1	Float Bowl Screws	2.0	0.20	18 in-lb	
2	Cover Mounting Bolts	2.9	0.30	26 in-lb	L
3	Chamber Case Cover Bolts	4.9	0.50	43 in-lb	
4	Governor Arm Mounting Nut	7.4	0.75	65 in-lb	
5	Carburetor Cover Bolts	8.8	0.90	78 in-lb	
6	Link Lever Mounting Bolts	8.8	0.90	78 in-lb	L

AD: Apply adhesive agent.

L: Apply a non-permanent locking agent.

## 3-6 FUEL SYSTEM

### Specifications

Item	Standard	Service Limit
<b>Throttle Pedal and Cable</b>		
Throttle pedal free play	5 ~ 10 mm (0.2 ~ 0.4 in.)	— — —
<b>Governer Link Mechanism</b>		
Throttle link lever bolt/shim clearance	0.05 ~ 0.3 mm (0.002 ~ 0.012 in.)	— — —
<b>Choke Cable</b>		
Choke cable free play	0 ~ 1 mm (0 ~ 0.04 in.)	— — —
<b>Carburetor</b>		
Idle speed	850 ~ 950 r/min (rpm)	— — —
Carburetor specifications:		
Make/type	Mikuni/BW26-18	— — —
Main jet	Front: #90, Rear: #92.5	— — —
Pilot jet	#41.3	— — —
Throttle valve	#165	— — —
Optional Parts:		
Main Jet:		
Altitude:		
0 ~ 500 m (0 ~ 1 600 ft):		
Front	#90 (92063-2403)	— — —
Rear	#92.5 (92063-2402)	— — —
500 ~ 1 500 m (1 600 ~ 4 900 ft):		
Front	#88.8 (92063-2413)	— — —
Rear	#91.3 (92063-2407)	— — —
1 500 ~ 2 500 m (4 900 ~ 8 200 ft):		
Front	#87.5 (92063-2405)	— — —
Rear	#90 (92063-2403)	— — —
2 500 ~ 3 500 m (8 200 ~ 11 000 ft):		
Front	#86.3 (92063-2363)	— — —
Rear	#88.8 (92063-2413)	— — —
3 500 ~ 4 500 m (11 000 ~ 14 000 ft):		
Front	#85 (92063-2376)	— — —
Rear	#87.5 (92063-2405)	— — —

## Throttle Pedal and Cable

### *Throttle Pedal Free Play Inspection*

- Refer to Throttle Pedal Free Play Inspection in the Periodic Maintenance chapter.

### *Throttle Pedal Free Play Adjustment*

- Refer to Throttle Pedal Free Play Adjustment in the Periodic Maintenance chapter.

### *Full Throttle Pedal Position Adjustment*

- Refer to Full Throttle Pedal Position Adjustment in the Periodic Maintenance chapter.

### *Throttle Cable Installation*

- Route the throttle cable correctly (see Appendix chapter).
- Adjust:  
Throttle Pedal Free Play Adjustment (see Periodic Maintenance chapter)

### **⚠ WARNING**

**Operation with incorrectly routed or improperly adjusted cable could result in an unsafe operating condition.**

### *Throttle Cable Lubrication*

Whenever the throttle cable is removed, lubricate the cable as follows.

- Apply a thin coating of grease to the cable upper and lower ends.
- Lubricate the cable with a penetrating rust inhibitor through a pressure cable lubber.

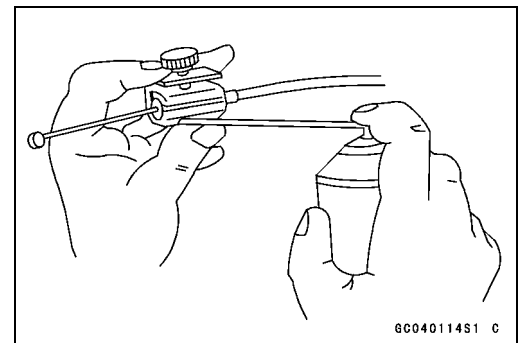

### *Throttle Cable Inspection*

- With the throttle cable disconnected at both ends, the cable should move freely [A] within the cable housing.
- ★ If the cable does not move freely after lubricating, if the cable is frayed, or if the housing is kinked, replace the cable.

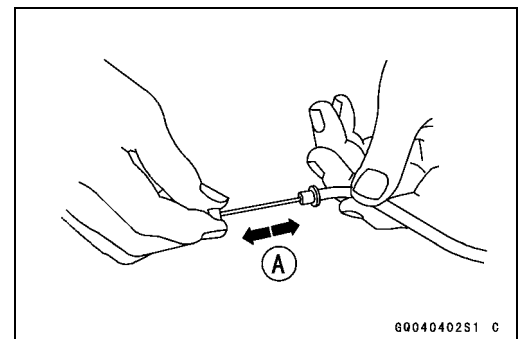

## 3-8 FUEL SYSTEM

### Governor Link Mechanism

#### Control Panel Assembly Removal

- Remove:
  - Cargo Bed
- Drill out the pop rivets [A] holding the control panel assembly shroud [B] with a drill bit of the 5 mm (0.02 in.) diameter.
- Drill only until the rivet head comes off. Do not drill through the hole.

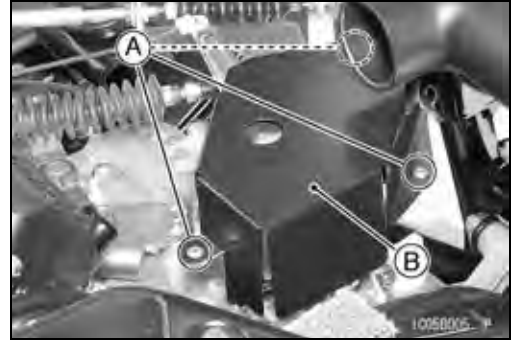

- Remove:
  - Control Panel Assembly Mounting Bolts [A], Collars and Washers
  - Control Panel Assembly [B]

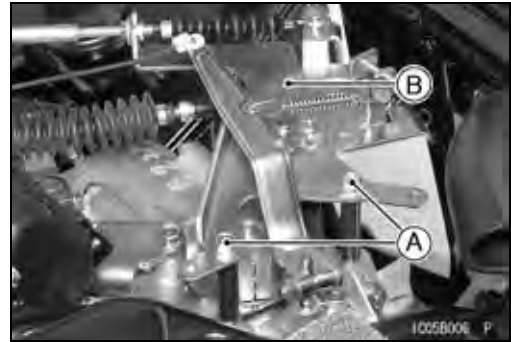

#### Control Panel Assembly Installation

- Install the governor arm [A] on the governor arm pivot [B].

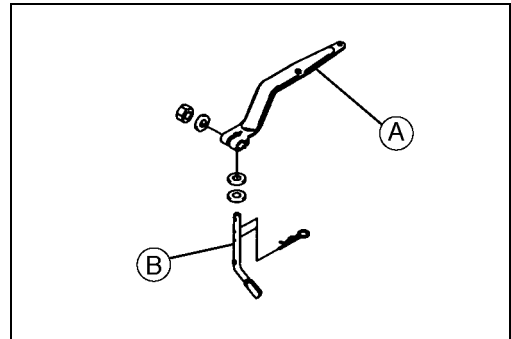

- Insert the bushings [A] in the holes of the governor arm and throttle lever on the carburetor from upper side with click [B].

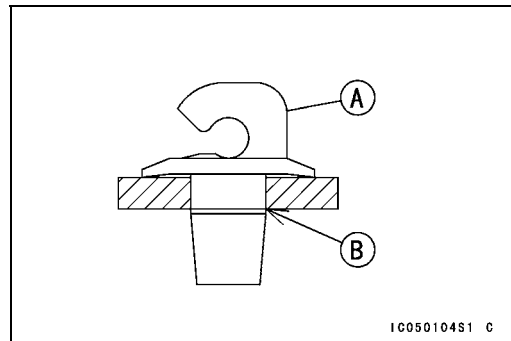

- Insert the link [A] in the hole of the bushings [B] from upper side.

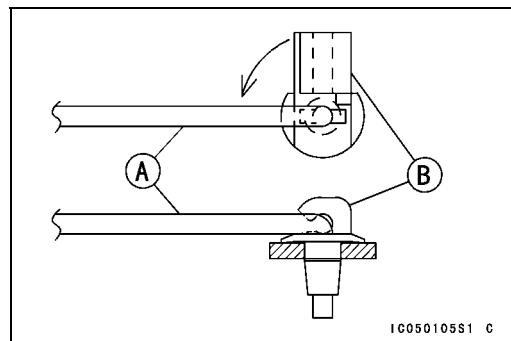

Governor Link Mechanism

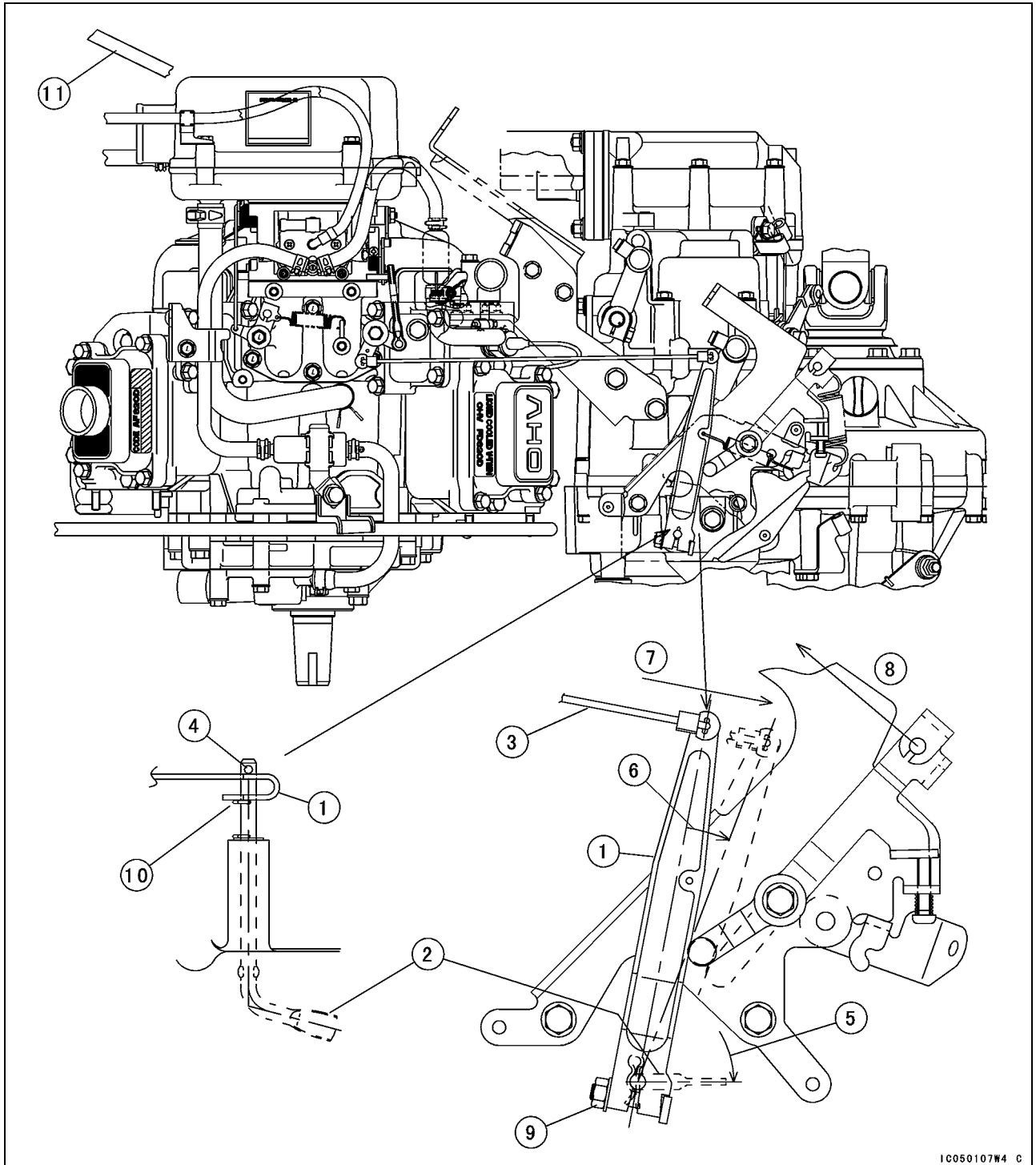

1. Governor Arm
2. Pivot Arm
3. Link
4. Hole
5. Turn the pivot arm.
6. Turn the governor arm.
7. Carburetor Throttle Full Open
8. Throttle Full Open
9. Governor Arm Clamp Nut
10. Pin
11. Front-Reverse Shift Cable

## 3-10 FUEL SYSTEM

### Governor Link Mechanism

- Turn the bushings [A] counterclockwise until fitting on the link with click [B].
- Fit the 4 bosses on the intake pipe of the engine with the carburetor cover after pass the link into the hole of the carburetor cover.
- Insert a suitable rod in the hole on the pivot arm, and turn the pivot arm clockwise until it cannot rotate.

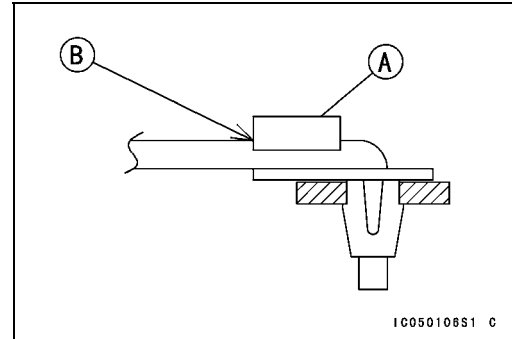

- Install the panel comp with bolts, collars, and washers, on the gear case while turning right counterclockwise.
- Make sure that the throttle lever on the carburetor is in the fully opened and closed position.
- Hook the spring for the governor and the spring for return.
- Install the throttle cable to the accelerator lever on the panel comp.
  1. Collar
  2. Washer
  3. Boss on Gear Case
  4. Governor Spring
  5. Return Spring
  6. Throttle Cable
  7. Panel Comp
  8. Accelerator Lever
- Install the control panel assembly shroud and pop rivet the shroud to the control panel assembly.

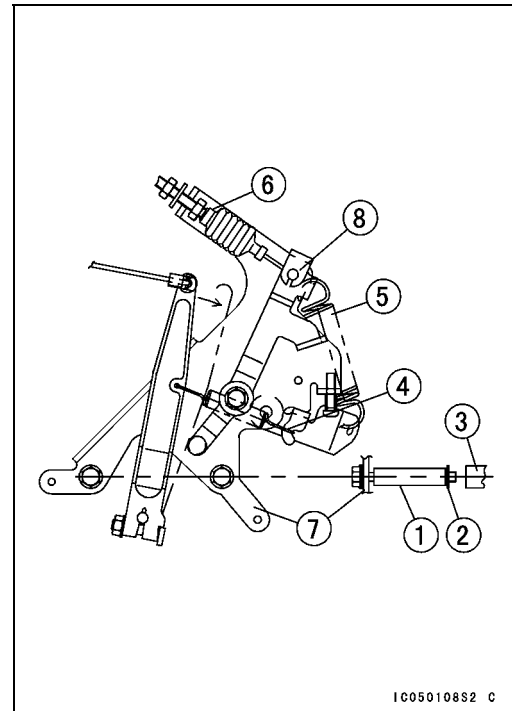

- Loosen (temporarily):
  - Accel Lever Stopper Screw [A]
  - Throttle Cable Mounting Nuts [B]
- Screw in the accel lever stopper screw until that the clearance [C] between oblong hole of the resin rod [D] connected on the carburetor and joint-ball [E] of the throttle lever of the carburetor is about 1 mm (0.04 in.).
- Tighten the throttle cable mounting nuts. In this case, do not extend the cable too much.
- Adjust:
  - Throttle Pedal Free Play Adjustment
  - Idle Speed Adjustment

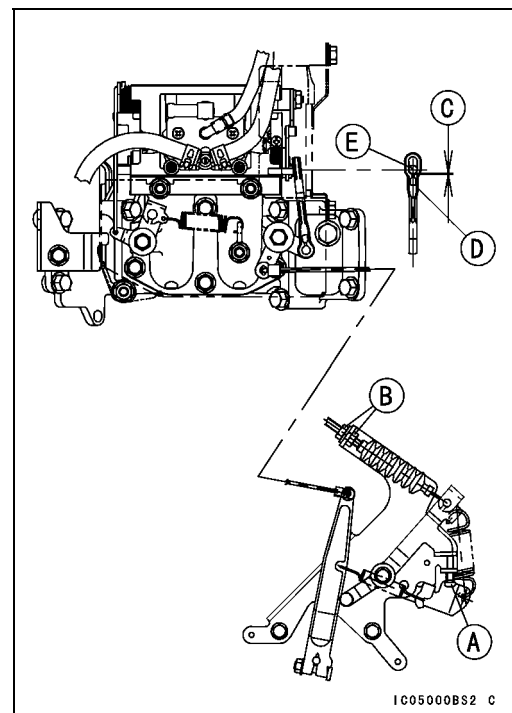

## Governor Link Mechanism

### Governor Arm and Throttle Link Removal

- Remove:
  - Cargo Bed
  - Control Panel Assembly Shroud
  - Carburetor Cover Bolts [A]
  - Carburetor Cover [B]

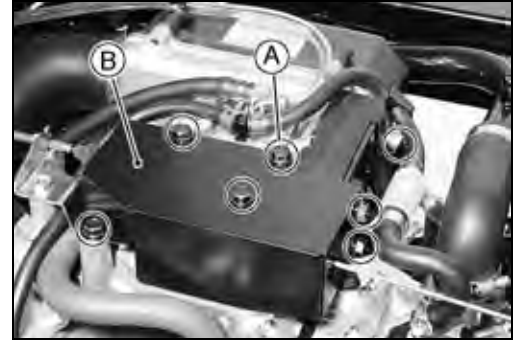

- Remove:
  - Throttle Link [A]
  - Governor Arm [B]

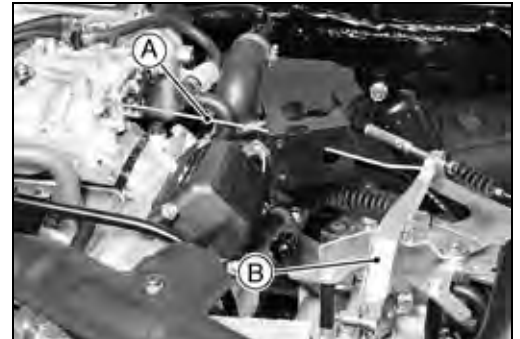

### Governor Arm Installation

- Adjust the governor arm on the shaft.
  - Loosen the nut [A].
  - Turn the governor shaft [B] clockwise as far as possible and hold it there.
  - Turn the governor arm [C] clockwise as far as possible (to make it fully open the throttle valve), hold it there, and tighten the nut.

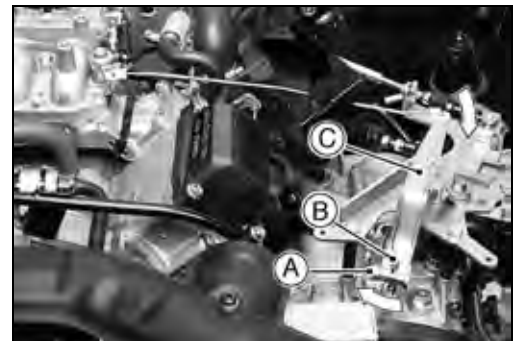

- Check that the governor arm [A] and the accel lever pin [B] fit together or there is a slight clearance between the governor arm and the accel lever pin, when the throttle lever is fully opened.

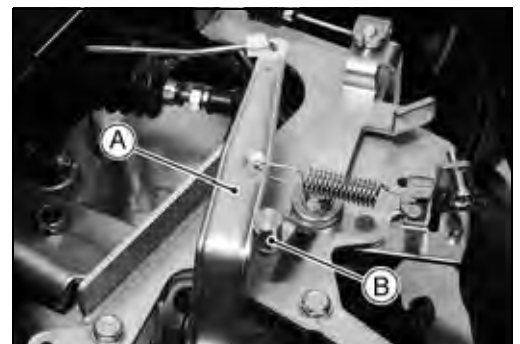

- Tighten:
  - Torque - Carburetor Cover Bolts: 8.8 N·m (0.90 kgf·m, 78 in·lb)

## 3-12 FUEL SYSTEM

### Governor Link Mechanism

#### Governor Assembly Removal

- Remove:

- Transmission Case (split)
- Governor Arm
- Governor Shaft Snap Pin [A]
- Governor Shaft [B]
- Washer (thin) [C]
- Washer (thick) [D]

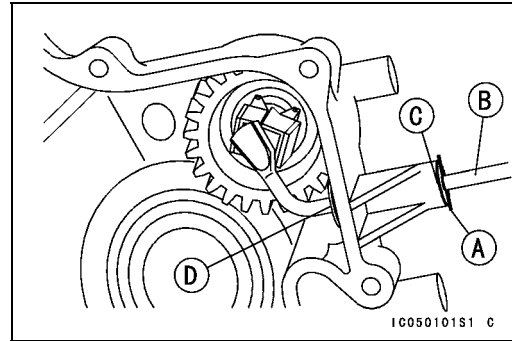

- Remove the governor assembly [A] with the sleeve [B] by prying the gear [C] with two suitable levers.

#### CAUTION

**Do not remove the governor assembly unless it is necessary. Once it has been removed, it must be replaced.**

- Remove the washer.

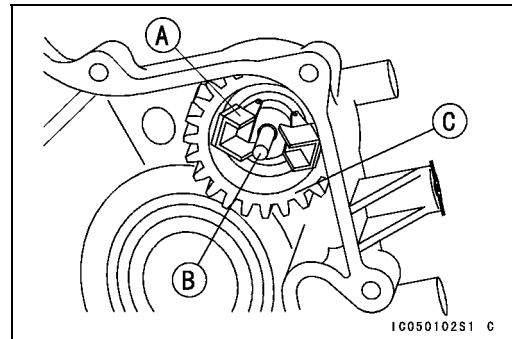

#### Governor Assembly Installation

- Fit the sleeve into the governor assembly, and install them as a set.

#### NOTE

- The sleeve and the governor assembly cannot be installed separately.
- Push the set onto the shaft until the step fits into the groove securely.

- Sleeve [A]
- Governor Assembly [B]
- Step [C]
- Washer [D]
- Groove [E]
- Shaft [F]
- 32 mm (1.26 in.) [G]

- Check that the gear turns freely and the weights move smoothly.

#### Governor Assembly Inspection

- Visually check the governor assembly for wear and damage.
- ★ If any part is worn or damaged, replace the assembly.

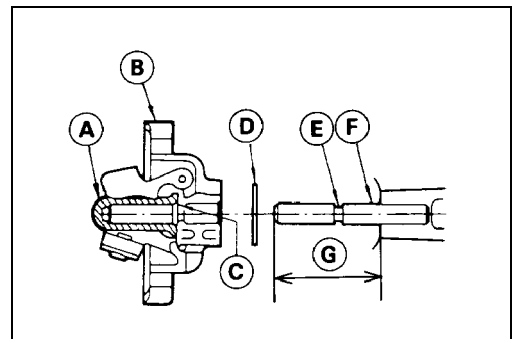



**Governor Link Mechanism**

*Throttle Link Lever Installation*

- Measure the clearance [A] between the seating surface of the bolt head and shims.

**Throttle Link Lever Bolt/Shim Clearance**

**Standard: 0.05 ~ 0.3 mm (0.002 ~ 0.012 in.)**

- ★ If the clearance is not within the specified range, adjust the clearance by adding or removing the shims.

- [B] Throttle Link Lever Bolt
- [C] Shims
- [D] Washers
- [E] Throttle Link Lever
- [F] Intake Pipe

**Shims**

Part No.	Thickness	Color
92180-2055	0.5 mm (0.020 in.)	Yellow
92180-2056	0.4 mm (0.016 in.)	Black
92180-2057	0.3 mm (0.012 in.)	White
92180-2060	0.6 mm (0.024 in.)	Green
92180-2061	0.7 mm (0.028 in.)	White

- Apply a non-permanent locking agent:  
Link Lever Mounting Bolt
- Tighten:  
**Torque - Link Lever Mounting Bolt: 8.8 N·m (0.90 kgf·m, 78 in·lb)**

*Maximum Engine Speed Inspection*

- Apply the parking brake.
- Put the shift lever in the neutral position.
- When the throttle pedal is fully depressed, make sure that the maximum engine speed is as follows.

Maximum Engine Speed	Governor Spring		
	Part No.	Color	Free Length [A]
about 3 600 rpm	39129-1011	Yellow	53.0 mm (2.09 in.)

- ★ If the engine maximum speed is not the specified value, check the governor spring and governor control system.

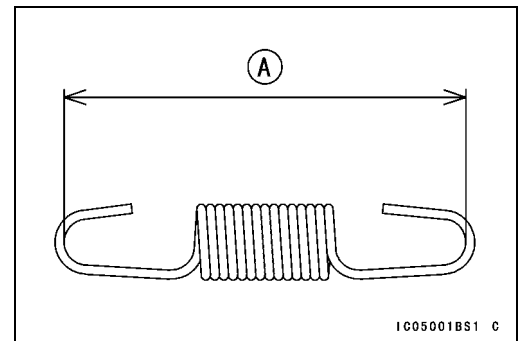
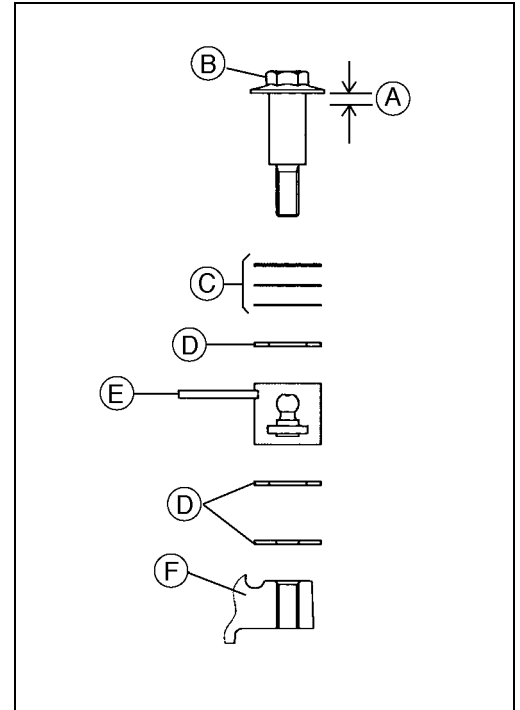

## 3-14 FUEL SYSTEM

### Choke Cable

#### *Choke Cable Free Play Inspection*

- Push in the choke knob all the way.
- Check the choke cable free play [A].
- Determine the amount of free play at the choke knob. Pull the choke knob until the starter lever [B] on the carburetor begins to turn; the amount of choke knob travel is the amount of free play.
- ★ If the free play is not correct, adjust the choke cable.

#### **Choke Cable Free Play**

**Standard: 0 ~ 1 mm (0 ~ 0.04 in.)**

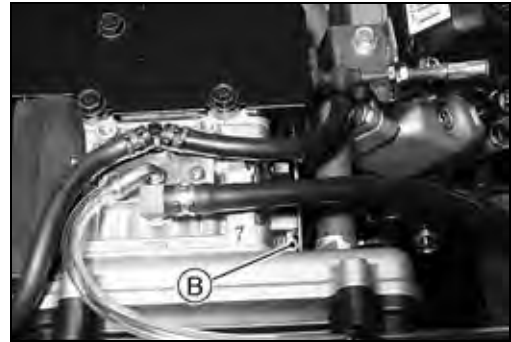

#### *Choke Cable Free Play Adjustment*

- Remove:
  - Cargo Bed (tilt up)
- Loosen the mounting nuts [A] and slide the adjuster [B] until the cable has the proper amount of free play.
- Tighten the mounting nuts securely.

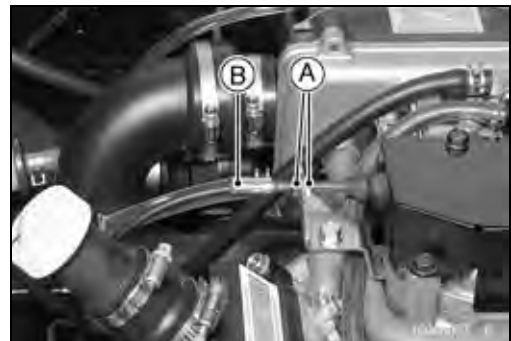

#### *Choke Cable Installation*

- Route the choke cable correctly (see the Appendix chapter).
- Adjust:
  - Choke Cable Free Play Adjustment

#### **⚠ WARNING**

**Operation with incorrectly routed or improperly adjusted cable could result in an unsafe operating condition.**

#### *Choke Cable Lubrication*

Whenever the choke cable is removed, lubricate the cable as follows.

- Lubricate the cable with a penetrating rust inhibitor through the pressure cable luber.

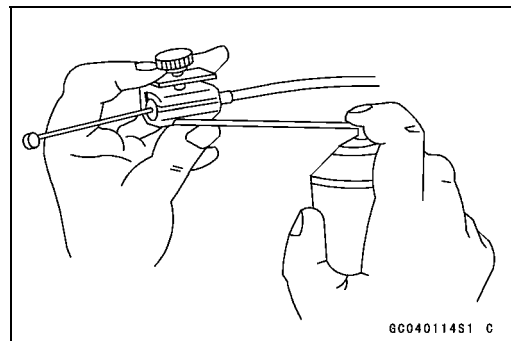

## Choke Cable

### *Choke Cable Inspection*

- With the choke cable disconnected at both ends, the cable should move freely [A] within the cable housing.
- ★ If the cable does not move freely after lubricating, if the cable is frayed, or if the housing is kinked, replace the cable.

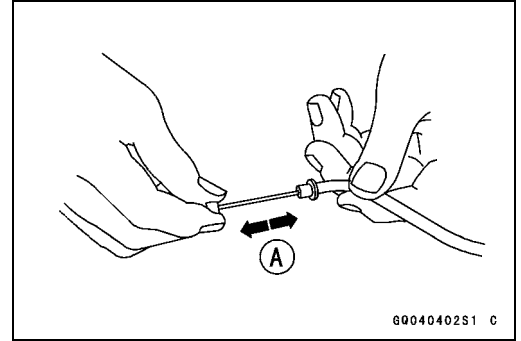

## 3-16 FUEL SYSTEM

### Carburetor

#### *Idle Speed Inspection*

- Refer to Idle Speed Inspection in the Periodic Maintenance chapter.

#### *Idle Speed Adjustment*

- Refer to Idle Speed Adjustment in the Periodic Maintenance chapter.

#### *Fuel System Cleanliness Inspection*

- Refer to Fuel System Cleanliness Inspection in the Periodic Maintenance chapter.

#### *Carburetor Removal*

### **⚠ WARNING**

**Gasoline is extremely flammable and can be explosive under certain conditions. Turn the ignition switch OFF. Do not smoke. Make sure the area is well-ventilated and free from any source of flame or sparks; this includes any appliance with a pilot light.**

- Remove:
  - Cargo Bed (tilt up)
  - Coolant (drain)
  - Carburetor Cover (See Governor Arm and Throttle Link Removal)
  - Fuel Hose [A]
  - Air Vent Tube [B]
  - Coolant Hoses [C]
  - Breather Hose [D]
  - Link [E]
  - Chamber Cover [F]
- Remove:
  - Carburetor Mounting Bolts [A]
  - Chamber Case [B]

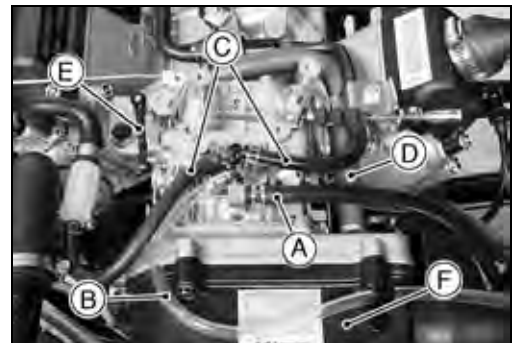

## Carburetor

- Remove:
  - Carburetor [A]
  - Choke Link [B]

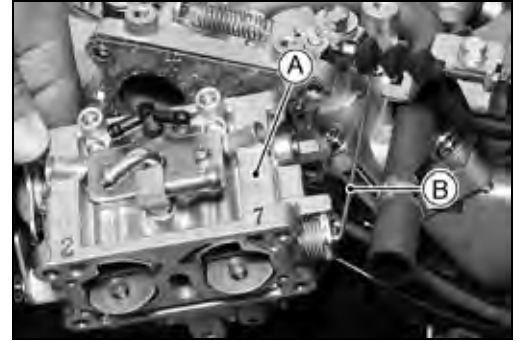

- After removing the carburetor, stuff pieces of lint-free, clean cloth into the carburetor holder and the air cleaner duct to keep dirt out of the engine and air cleaner.

**CAUTION**

**If dirt gets through into the engine, excessive engine wear and possibly engine damage will occur.**

### Carburetor Installation

- Install:
  - Pins [A]
  - New Gasket [B]
  - Choke Link [C]
  - Carburetor



- Install:
  - Pins [A]
  - New Gasket [B]

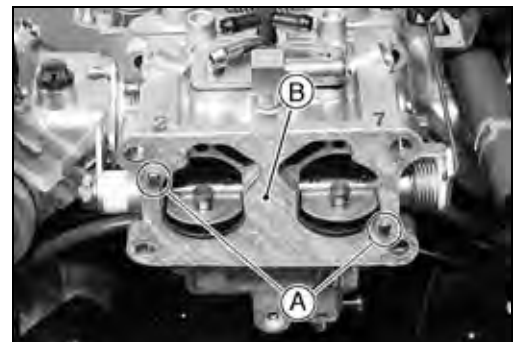

- Install:
  - Chamber Case [A]
  - Carburetor Mounting Bolts [B]
- ★ When installing the cover [C], note the following.
  - Apply a non permanent locking agent:
    - Cover Mounting Bolts [D]
  - Tighten:
    - Torque - Cover Mounting Bolts: 2.9 N-m (0.30 kgf-m, 26 in-lb)**

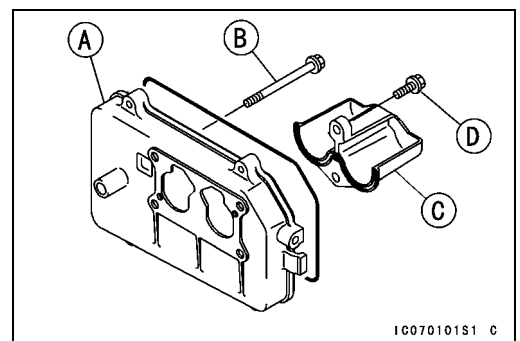

1C070101S1 C

## 3-18 FUEL SYSTEM

### Carburetor

- Install:
  - Chamber Case Cover [A]
  - Clamp [B]
- Tighten:
  - Torque - Chamber Case Cover Bolts [C]: 4.9 N-m (0.50 kgf-m, 43 in-lb)**

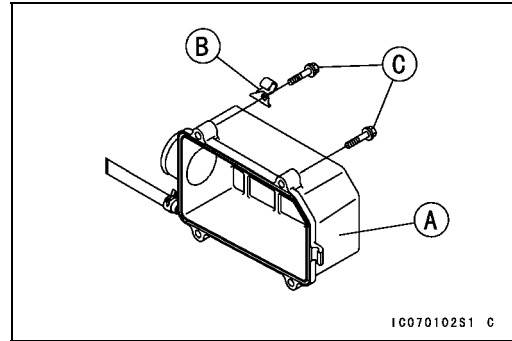

- When installing the air duct [A] to the tube [B] on the chamber case cover, note the following.
- Strip off the old sealant around the tube and inside of the air duct.
- Apply silicone sealant [C] around the tube for filling the gap between the tube and duct.

**Sealant - Kawasaki Bond (Silicone Sealant): 56019-120**

- Torque:
  - Torque - Air Duct Clamp [D]: 0.98 N-m (0.10 kgf-m, 8.7 in-lb)**

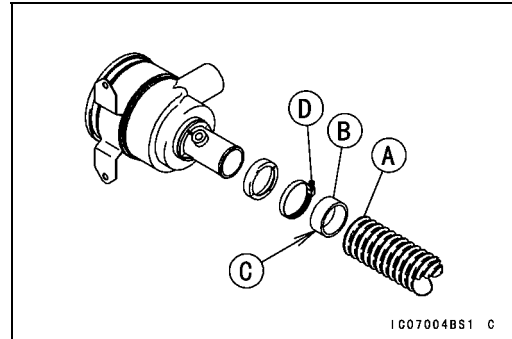

- Install the parts removed.
- Adjust:
  - Throttle Pedal Free Play Adjustment
  - Choke Cable Free Play Adjustment
  - Idle Speed Adjustment

### Carburetor Disassembly

#### **⚠ WARNING**

**Gasoline is extremely flammable and can be explosive under certain conditions. Turn the ignition switch OFF. Do not smoke. Make sure the area is well-ventilated and free from any source of flame or sparks; this includes any appliance with a pilot light.**

- Remove:
  - Carburetor (see Carburetor Removal)
  - Float Bowl Screws [A]
  - Float Bowl [B]

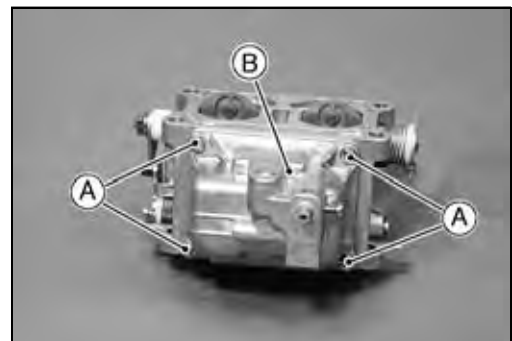

## Carburetor

- Remove:  
Pin [A]  
Float [B]

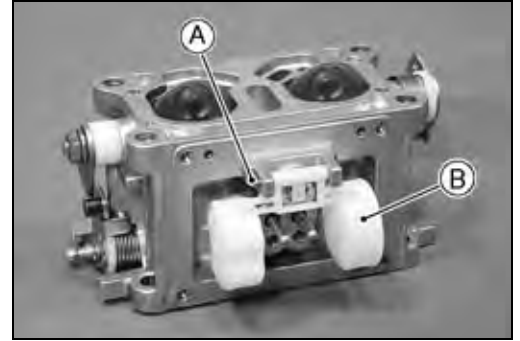

- Remove:  
Pilot Jets [A]

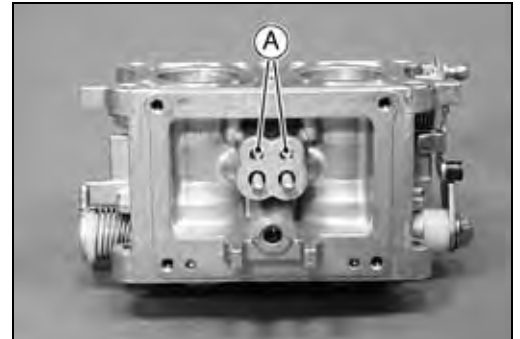

- Remove:  
Main Jets [A]



### *Carburetor Assembly*

- Tighten:  
Torque - Float Bowl Screws: 2.0 N·m (0.20 kgf·m, 18 in·lb)

## 3-20 FUEL SYSTEM

### Carburetor

#### Carburetor Cleaning

#### **⚠ WARNING**

Clean the carburetor in a well-ventilated area, and take care that there is no spark or flame anywhere near the working area; this includes any appliance with a pilot light. Because of the danger of highly flammable liquids, do not use gasoline or low flash-point solvents to clean the carburetor.

#### **CAUTION**

Do not use compressed air on an assembled carburetor, the float may be crushed by the pressure. Remove as many rubber or plastic parts from the carburetor as possible before cleaning the carburetor with a cleaning solution. This will prevent damage or deterioration of the parts. The carburetor body has plastic parts that cannot be removed. Do not use a strong carburetor cleaning solution which could attack these parts; instead, use a mild high flash point cleaning solution safe for plastic parts. Do not use wire or any other hard instrument to clean carburetor parts, especially jets, as they may be damaged.

- Disassemble the carburetor.
- Immerse all the metal parts in a carburetor cleaning solution.
- Rinse the parts in water.
- When the parts are clean, dry them with compressed air.
- Blow through the air and fuel passages with compressed air.
- Assemble the carburetor.

#### Carburetor Inspection

#### **⚠ WARNING**

Gasoline is extremely flammable and can be explosive under certain conditions. Turn the ignition switch OFF. Do not smoke. Make sure the area is well-ventilated and free from any source of flame or sparks; this includes any appliance with a pilot light.

- Turn the throttle and choke shafts to check that the throttle and choke valves move smoothly.
  - Throttle Valves [A]
  - Choke Valves [B]
- ★ If the valves do not move smoothly, replace the damaged parts.

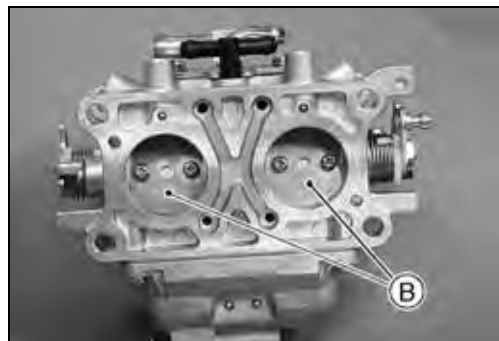



**Carburetor**

- Check that the gasket [A] on the float bowl is in good condition.
- ★ If the gasket is not in good condition, replace it.

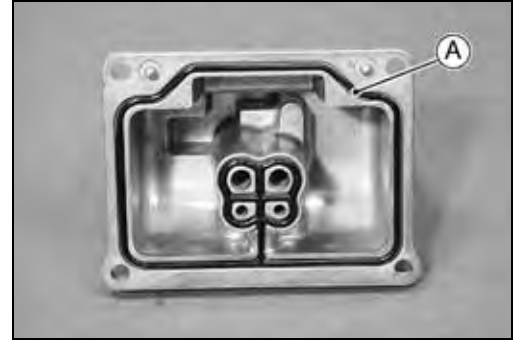

- Check the float [A] for cracks.
- ★ If there are any cracks, replace the float.

**NOTE**

○ Float height can not be adjusted.

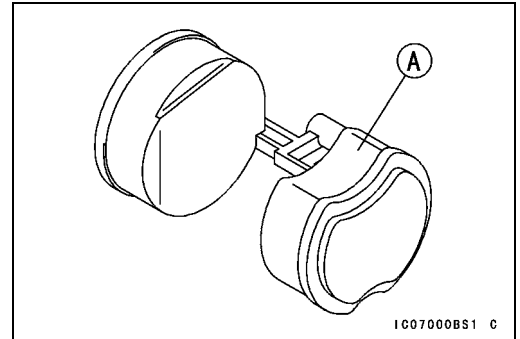

- Check the tip [A] of the float valve needle [B]. It should be smooth, without any grooves, scratches, or tears.
- ★ If the tip is damaged [C], replace the valve needle.
- ★ Push the rod [D] into the valve needle, and then release [E] it.
- ★ If the rod does not spring out, replace the valve needle.

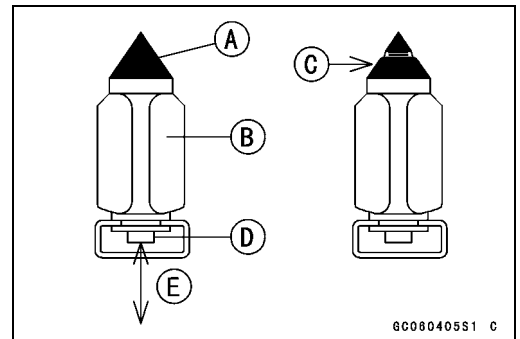

**Coolant Filter Cleaning**

Before winter season starts, clean the filter of carburetor system.

- Drain the coolant (see Cooling System chapter).
- Remove the filter [A] from the cooling hoses [B].
- Blow off dirt and sediment on the filter with compressed air.

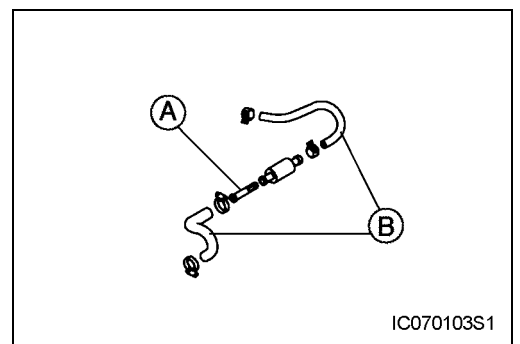

**Coolant Valve Inspection**

- Drain the coolant (see Cooling System chapter).
- Remove the coolant valve [A].
- Inspect the coolant valve at room temperature.
- ★ If the valve is closed, replace the valve with a new one.
- To check valve opening just blow through the valve.

**Valve Closing Temperature (for reference)**

Standard: 70°C (158°F) or more at 25 kPa (0.25 kgf/cm<sup>2</sup>, 3.6 psi)

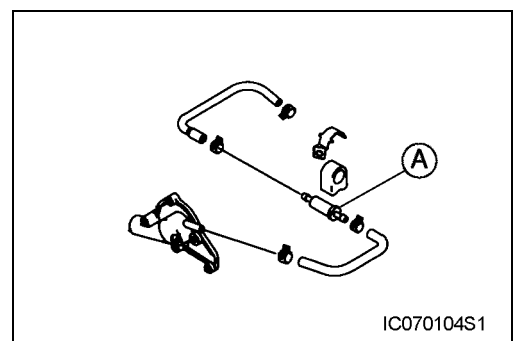

## 3-22 FUEL SYSTEM

### Air Cleaner

#### *Air Cleaner Element Cleaning*

- Refer to Air Cleaner Element Cleaning in the Periodic Maintenance chapter.

#### *Air Cleaner Housing Removal*

- Remove:
  - Air Ducts [A]
  - Mounting Bolts [B]
  - Air Cleaner Housing [C]

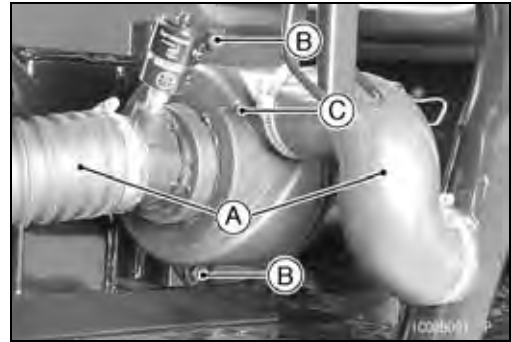

#### *Air Cleaner Housing Installation*

- Tighten:
  - **Torque - Air Cleaner Housing Mounting Bolts: 20 N·m (2.0 kgf·m, 14 ft·lb)**
- When installing the air duct [A] to the tube [B] on the chamber case cover, note the following.
  - Strip off the old sealant around the tube and inside of the air duct.
  - Apply silicone sealant [C] around the tube for filling the gap between the tube and duct.
  - **Sealant - Kawasaki Bond (Silicone Sealant): 56019-120**
- Torque:
  - **Torque - Air Duct Clamp [D]: 0.98 N·m (0.10 kgf·m, 8.7 in·lb)**

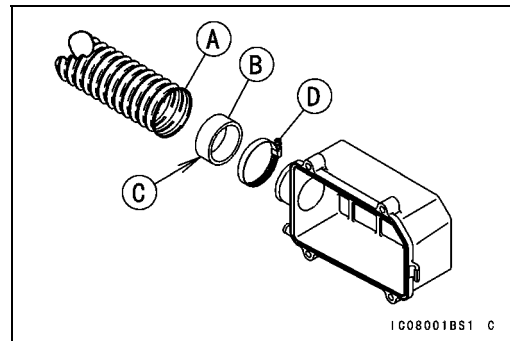

#### *Air Cleaner Housing Dust and/or Water Inspection*

- Refer to Air Cleaner Housing Dust and/or Water Inspection in the Periodic Maintenance chapter.

## Fuel Pump and Fuel Filter

### Fuel Pump and Fuel Filter Removal

#### **⚠ WARNING**

Gasoline is extremely flammable and can be explosive under certain conditions. Turn the ignition switch OFF. Do not smoke. Make sure the area is well-ventilated and free from any source of flame or sparks; this includes any appliance with a pilot light.

- Remove:
  - Cargo Bed (tilt up)
  - Fuel Hoses (disconnect)
  - Fuel Pump [A]
  - Fuel Filter [B]

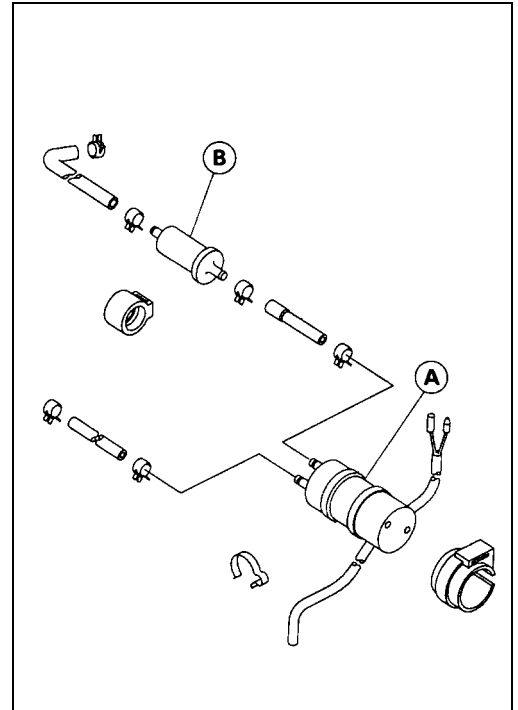

### Fuel Pump Installation

- Install the rubber damper [A] to the pump so that the projection [B] on the damper aligns with the paint mark [C] on the pump.
- Connect the fuel hose from the filter to the fitting marked INLET, and the hose to the carburetor to the another fitting.

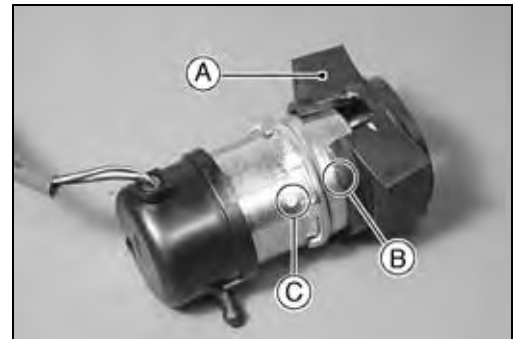

### Fuel Filter Installation

- Install the fuel filter [A] so that the arrow [B] on it shows the fuel flow from the fuel tank to the fuel pump.

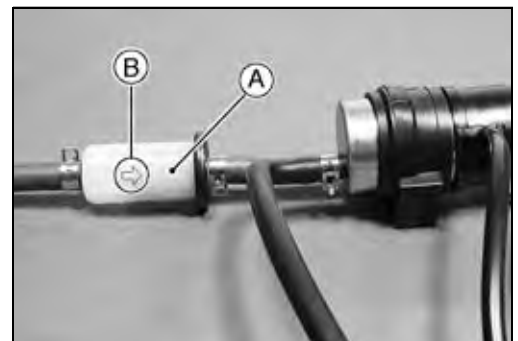

### Fuel Filter Inspection

- Refer to Fuel Filter Inspection in the Periodic Maintenance chapter.

## 3-24 FUEL SYSTEM

### Fuel Tank

#### Fuel Tank Removal

#### **⚠ WARNING**

Fuel is extremely flammable and can be explosive under certain conditions. Turn the main switch OFF. Do not smoke. Make sure the area is well-ventilated and free from any source of flame or sparks; this includes any appliance with a pilot light.

- Remove:
  - Mounting Rivets [A]
  - Screws [B]
- Tilt up the front seat [A].
- Remove the fuel tank cap [B].
- Remove:
  - Mounting Rivets [C]
  - Screws [D]
  - Fuel Tank Cover [E]
  - Front Seat Lower Cover (Front Side) [F]
- Remove:
  - Screws [A]
  - Front Seat Lower Cover (Rear Side) [B]
- Disconnect the fuel hose [A].
- Remove the fuel tank mounting bolt [B].
- Remove the fuel tank mounting bolts [A].

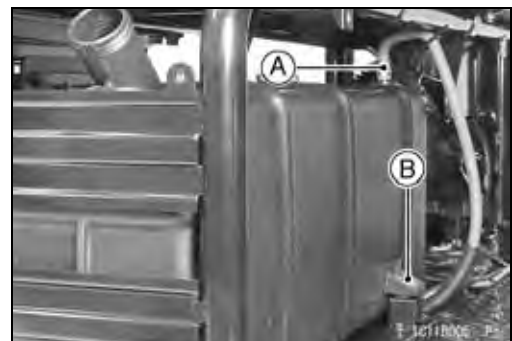
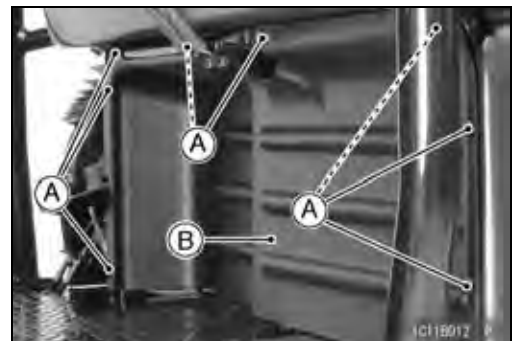
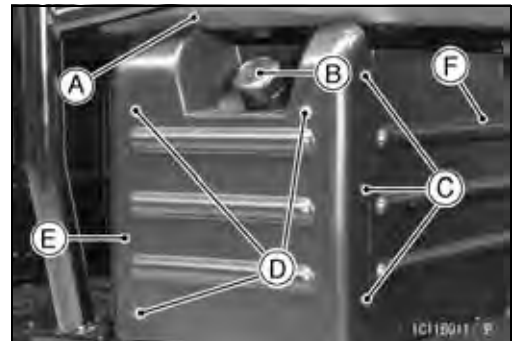
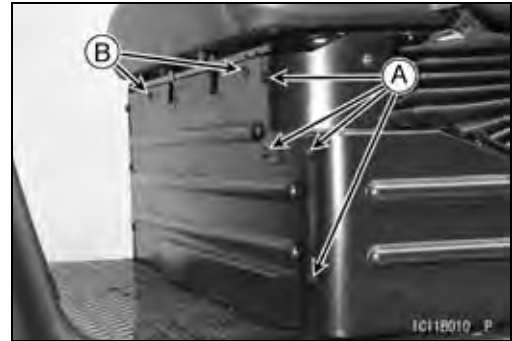

## Fuel Tank

- Remove the fuel tank [A].



### Fuel Tank Installation

- ★ If the rubber dampers [A] were removed, install them onto the fuel tank with an adhesive.

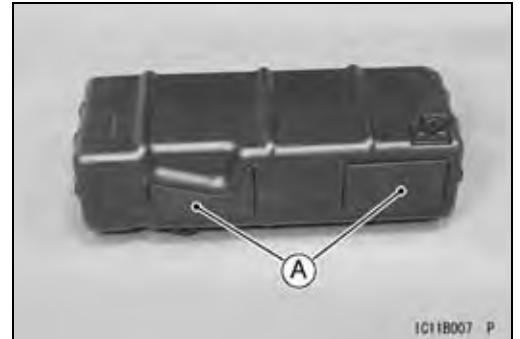

- Install the dampers on the collars, as shown.
- Position the damper [A] so that its thicker side [B] faces the front side.
- Position the dampers [C] so that its thicker side [D] faces downward.

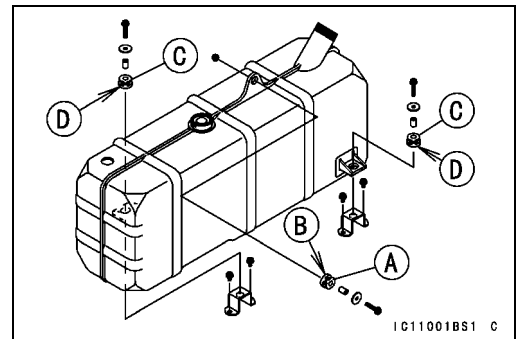

### Fuel Tank Cleaning/Inspection

#### ⚠ WARNING

Clean the tank in a well-ventilated area, and take care that there is no spark or flame anywhere near the working area. Because of the danger of highly flammable liquids, do not use gasoline or low flash point solvents to clean the tank.

- Remove the fuel tank and drain it.
- Remove the fuel level gauge [A].
- Remove the seal [A] with the fitting [B] and hose [C].
- Pour some high flash-point solvent into the fuel tank and shake the tank to remove dirt and fuel deposits.
- Pour the solvent out of the tank.
- Dry the tank with compressed air.
- Visually inspect the following for any damage.
  - Fuel Tank Cap Gasket
  - Fuel Level Gauge Cap
  - Fuel Hose Seal on Fuel Tank
- Replace them if they are damaged.

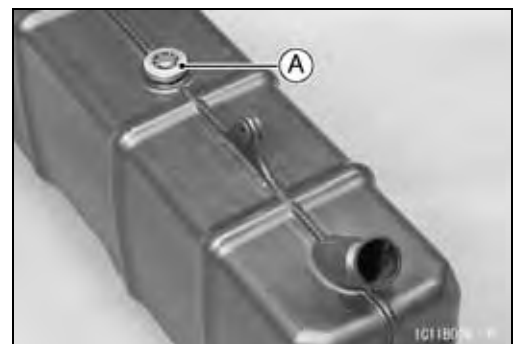

## 3-26 FUEL SYSTEM

### Fuel Tank

○ Push down the gasket [A] into the bottom of fuel tank cap [B], and insert the flange portions [C] of gasket to the cap threads.

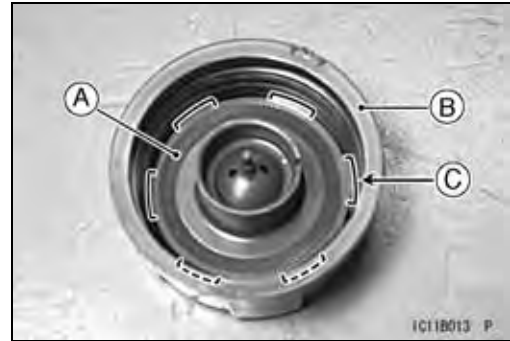

# Cooling System

## Table of Contents

Exploded View.....	4-2
Specifications .....	4-4
Sealant .....	4-5
Flow Chart .....	4-6
Coolant .....	4-9
Coolant Level Inspection.....	4-9
Coolant Draining .....	4-9
Coolant Filling .....	4-9
Pressure Testing .....	4-9
Water Pump.....	4-10
Water Pump Removal.....	4-10
Water Pump Installation.....	4-11
Water Pump Inspection.....	4-12
Radiator and Radiator Fan .....	4-13
Radiator Removal .....	4-13
Radiator Inspection .....	4-14
Radiator Cleaning .....	4-14
Radiator Cap .....	4-15
Radiator Cap Inspection .....	4-15
Thermostat .....	4-16
Thermostat Removal.....	4-16
Thermostat Installation.....	4-16
Thermostat Inspection .....	4-16
Hoses and Pipes .....	4-18
Hose and Pipe Installation .....	4-18
Hose Inspection .....	4-18
Radiator Fan Switch, Coolant Temperature Warning Light Switch.....	4-19
Radiator Fan Switch, Coolant Temperature Warning Light Switch Removal .....	4-19
Radiator Fan Switch, Coolant Temperature Warning Light Switch Installation .....	4-19
Radiator Fan Switch, Coolant Temperature Warning Light Switch Inspection.....	4-19

# 4-2 COOLING SYSTEM

## Exploded View

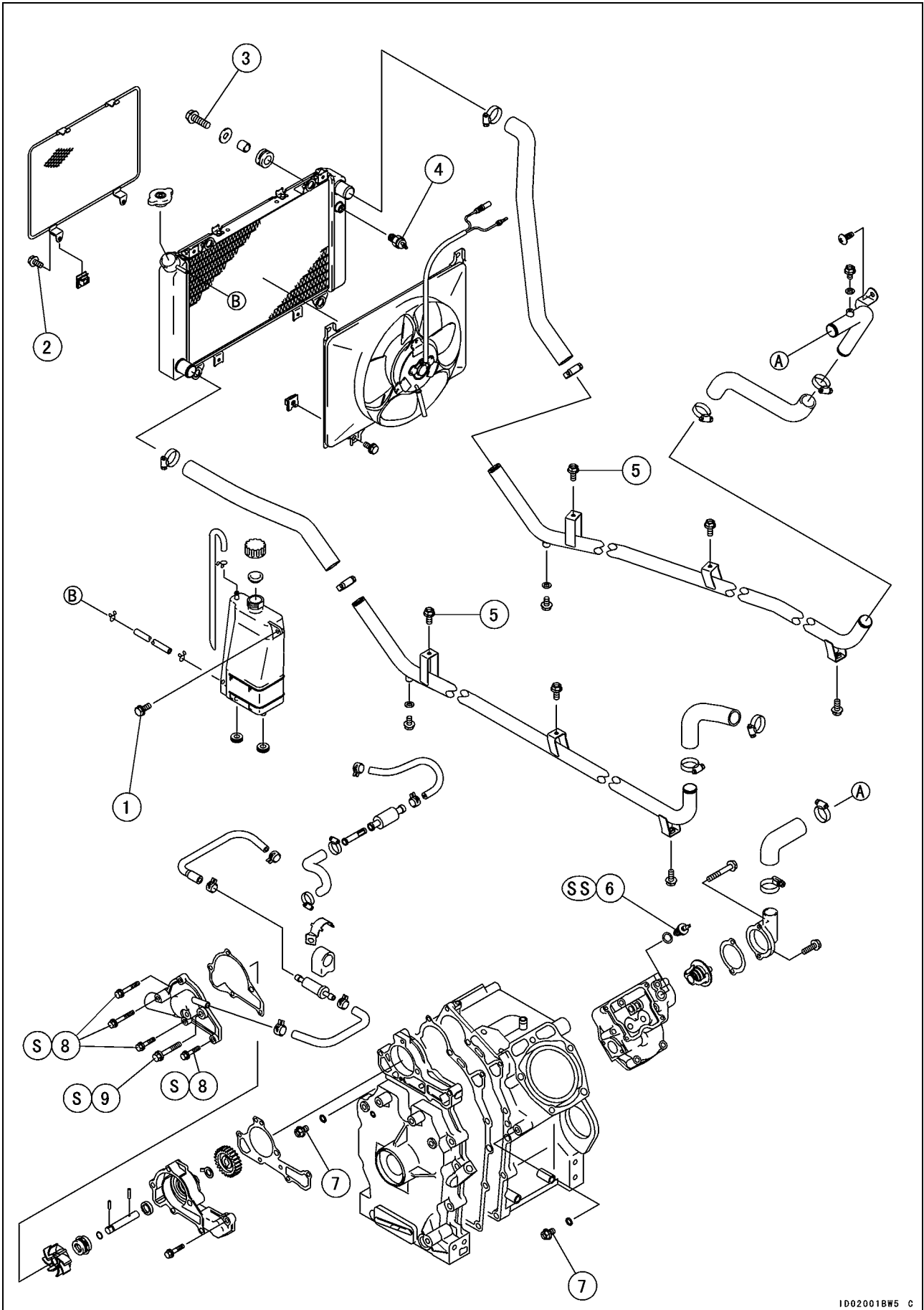

1002001BW5 C



**Exploded View**

No.	Fastener	Torque			Remarks
		N-m	kgf-m	ft-lb	
1	Coolant Reservoir Mounting Bolt	4.4	0.45	39 in-lb	
2	Radiator Screen Bolts	8.8	0.90	78 in-lb	
3	Radiator Mounting Bolts	8.8	0.90	78 in-lb	
4	Radiator Fan Switch	25	2.5	18	
5	Water Pipe Bolts	8.8	0.90	78 in-lb	
6	Coolant Temperature Warning Light Switch	23	2.3	17	SS
7	Coolant Drain Plugs (Cylinder )	17	1.7	12	
8	Water Pump Cover Bolts (M6)	8.8	0.90	78 in-lb	S
9	Water Pump Cover Bolts (M8)	25	2.5	18	S

S: Follow specified tightening sequence.

SS: Apply silicone sealant.

## 4-4 COOLING SYSTEM

### Specifications

Item	Standard	Service Limit
<b>Coolant</b>		
Type	Permanent type of antifreeze (Soft water and ethylene glycol plus corrosion and rust inhibitor chemicals for aluminum engines and radiators)	---
Color	Green	---
Mixed ratio	Soft water 50%, coolant 50%	---
Freezing point	-35°C (-31°F)	---
Total amount	4.6 L (4.9 US qt)	---
<b>Water Pump</b>		
Water pump shaft diameter	9.975 ~ 9.990 mm (0.392 ~ 0.393 in.)	9.94 mm (0.39 in.)
Water pump shaft bearing inside diameter	10.020 ~ 10.038 mm (0.394 ~ 0.395 in.)	10.09 mm (0.40 in.)
<b>Radiator Cap</b>		
Relief pressure	93 ~ 123 kPa (0.95 ~ 1.25 kgf/cm <sup>2</sup> , 14 ~ 18 psi)	---
<b>Thermostat</b>		
Valve opening temperature	80.5 ~ 83.5°C (177 ~ 182°F)	---
Valve full opening lift	8 mm (0.3 in.) or more @95°C (203°F)	---

**Sealant**

**Kawasaki Bond (Silicone Sealant):  
56019-120**

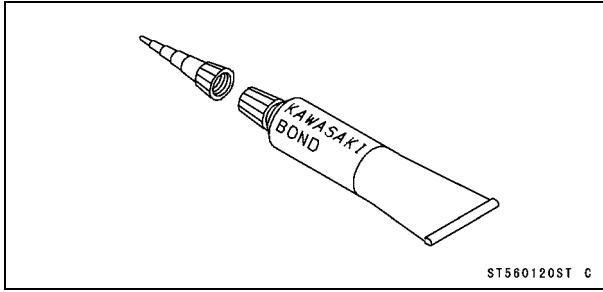

# 4-6 COOLING SYSTEM

## Flow Chart

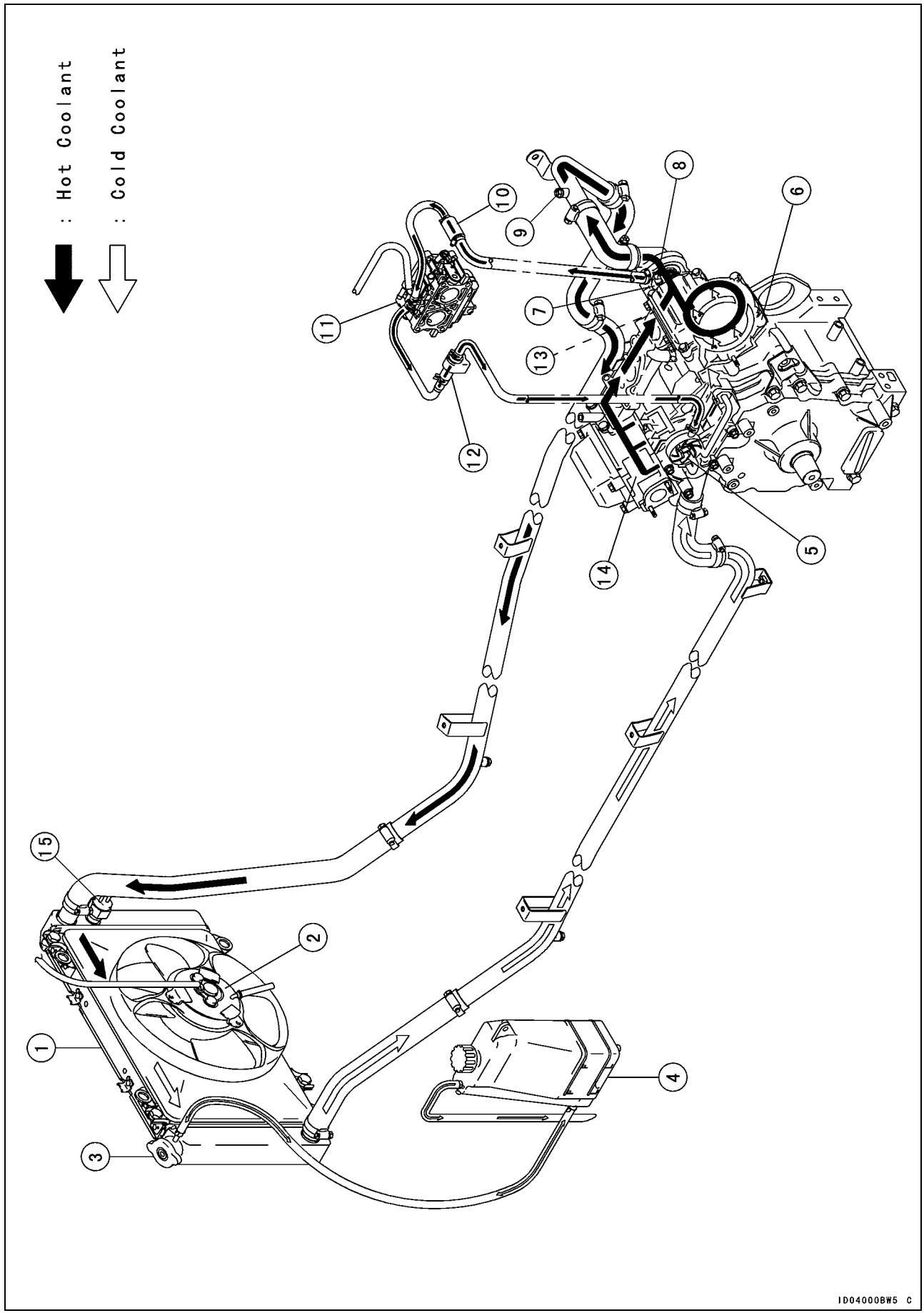

1D04000BW5 C

### Flow Chart

---

1. Radiator
2. Radiator Fan
3. Radiator Cap
4. Reservoir Tank
5. Water Pump
6. Cylinder
7. Thermostat
8. Coolant Temperature Warning Light Switch
9. Air Bleeder Bolt (Water Pipe)
10. Filter
11. Carburetor
12. Thermo Valve
13. Air Bleeder Bolt (Intake Manifold)
14. Cylinder Head
15. Radiator Fan Switch

## 4-8 COOLING SYSTEM

### Flow Chart

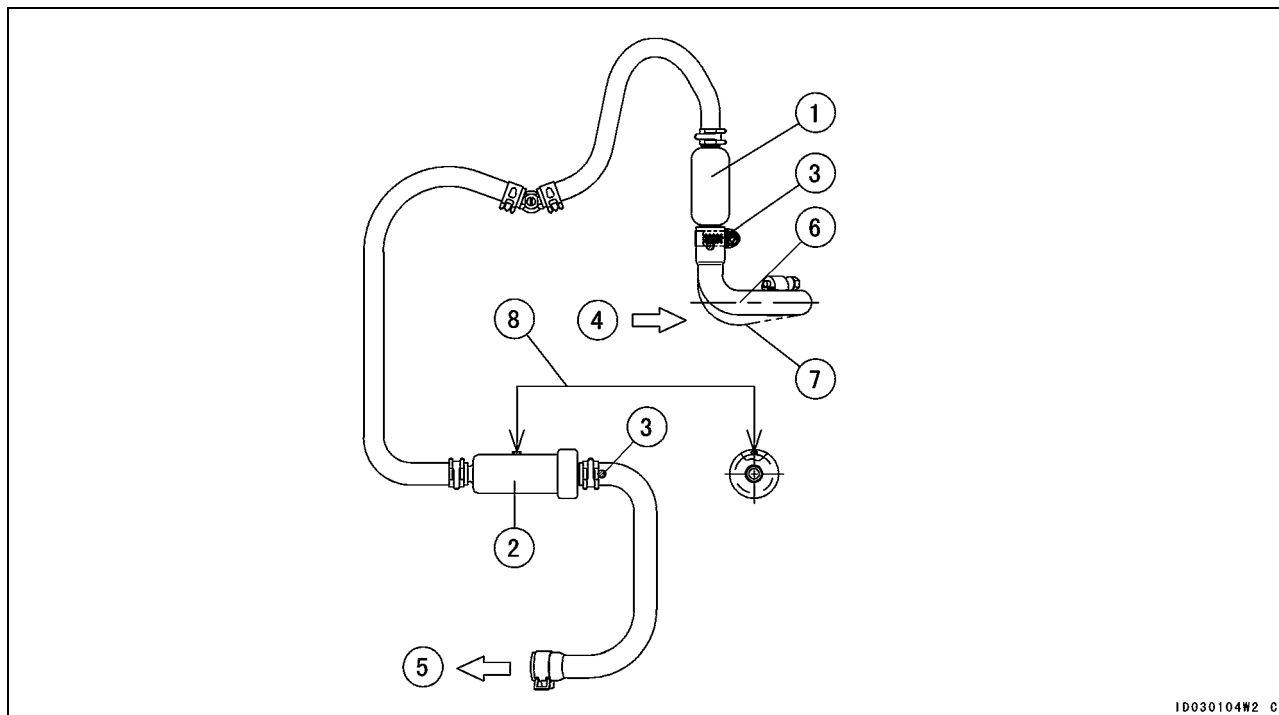

1. Filter
2. Thermo Valve
3. White Mark
4. Coolant Inlet
5. Coolant Outlet
6. Level the tube to the inlet pipe.
7. Do not bulge the tube as a dotted line.
8. Face the projection on the valve body to the carburetor.

**Coolant**

*Coolant Level Inspection*

**NOTE**

○ Check the level when the engine is cold (room of ambient temperature).

**CAUTION**

**Do not check the level through the coolant filler by removing the radiator cap. If the cap is removed, the coolant will flow out from the reservoir tank.**

- Check the coolant level in the reservoir tank [A] with the vehicle held perpendicularly.
- ★ If the coolant level is lower than the L (Low) [B] mark, remove the reservoir tank cap [C], then add coolant to the F (Full) [D] mark.

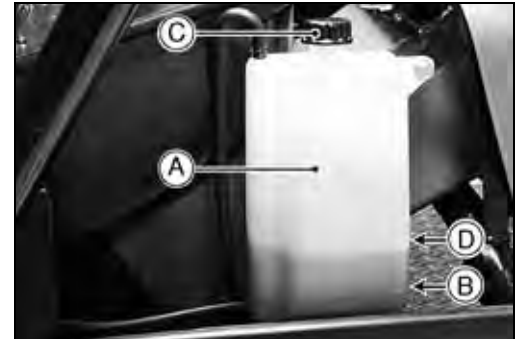

**CAUTION**

**For refilling, add the specified mixture of coolant and soft water. Adding water alone dilutes the coolant and degrades its anticorrosion properties. The diluted coolant can attack the aluminum engine parts. In an emergency, soft water can be added. But the diluted coolant must be returned to the correct mixture ratio within a few days. If coolant must be added often, or the reservoir tank has run completely dry; there is probably leakage in the cooling system. Check the system for leaks.**

*Coolant Draining*

- Refer to Coolant Draining in the Periodic Maintenance chapter.

*Coolant Filling*

- Refer to Coolant Filling in the Periodic Maintenance chapter.

*Pressure Testing*

- Remove the radiator cap, and install a cooling system pressure tester [A] and adapter [B] on the radiator filler neck [C].

**NOTE**

○ Wet the cap sealing surfaces with water or coolant to prevent pressure leakage.

- Build up pressure in the system carefully until the pressure reaches 123 kPa (1.25 kgf/cm<sup>2</sup>, 18 psi).

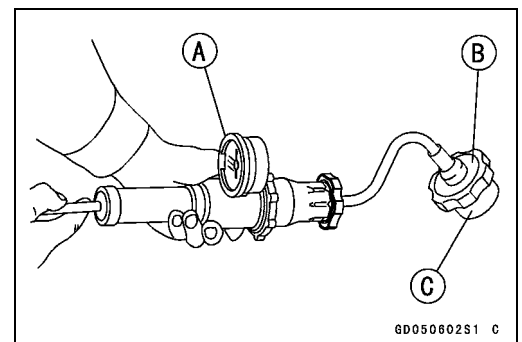

**CAUTION**

**During pressure testing, do not exceed the pressure for which the system is designed. The maximum pressure is 123 kPa (1.25 kgf/cm<sup>2</sup>, 18 psi).**

- Watch the gauge for at least 6 seconds.
- ★ If the pressure holds steady, the system is all right.
- ★ If the pressure drops soon, check for leaks.

## 4-10 COOLING SYSTEM

### Water Pump

#### *Water Pump Removal*

- Remove:
  - Torque Converter
  - Coolant (drain)
  - Water Hoses [A]
  - Water Pump Cover Bolts [B]
  - Water Pump Cover [C]
  
- Remove:
  - Water Pump Housing Bolt [A]
  - Water Pump Housing [B]
  
- Remove:
  - Water Pump Drive Gear [A]
  
- Remove:
  - Pin [A]
  - Washer [B]
  
- Remove:
  - Water Pump Impeller [A]
  - Shaft [B]
  - Pin [C] and O-ring [D]

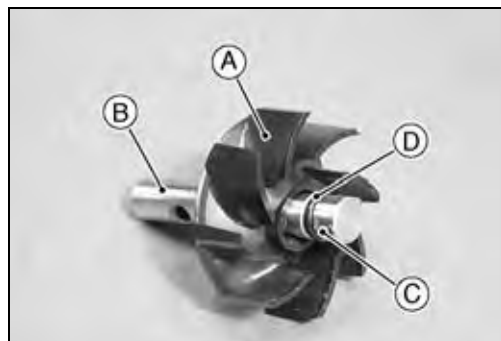
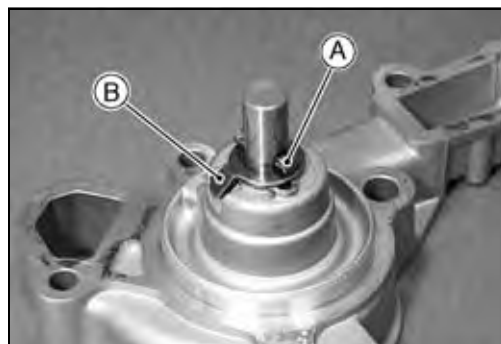
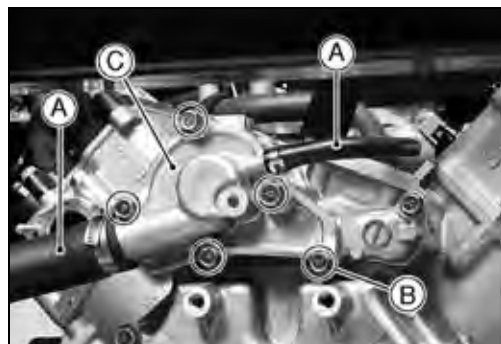



**Water Pump**

- Remove:  
 Mechanical Seal [A]  
 Oil Seal [B]

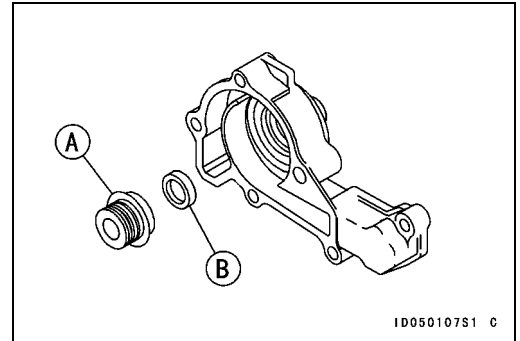

*Water Pump Installation*

- Clean the sliding surface of a new mechanical seal with a high-flash point solvent, and apply a little coolant to the sliding surface to give the mechanical seal initial lubrication.
- Apply coolant to the surfaces of the rubber seal and sealing seat [A], and press the rubber seal [B] and sealing seat into the impeller by hand until the seat bottoms out.

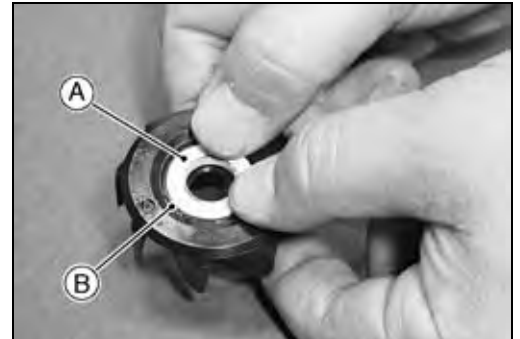

- Fit the washer tab [A] to the notch [B] of the housing.
- Fit the drive gear notches [C] to the pin [D].

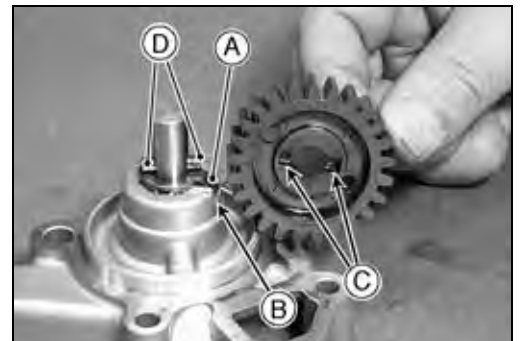

- Install the water pump housing turning the impeller so that the drive gear [A] engages with the camshaft gear [B].

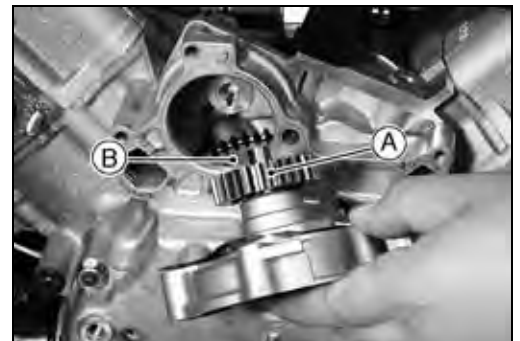

- Tighten the water pump cover bolts in the order shown.  
**Torque - Water Pump Cover Bolts (M6): 8.8 N·m (0.90 kgf·m, 78 in·lb)**  
**Water Pump Cover Bolt (M8): 25 N·m (2.5 kgf·m, 18 ft·lb)**

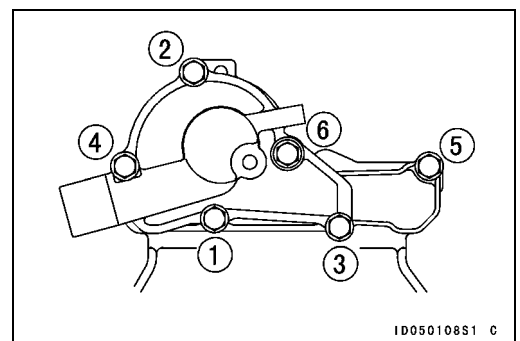

## 4-12 COOLING SYSTEM

### Water Pump

#### *Water Pump Inspection*

- Check the drainage outlet passage [A] at the bottom of the water pump body for coolant leakage.

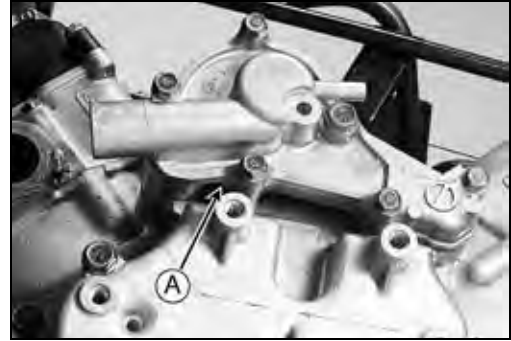

- ★ If the mechanical seal is damaged, the coolant leaks through the seal and drains through the passages. Replace the mechanical seal [A] or O-ring [B].

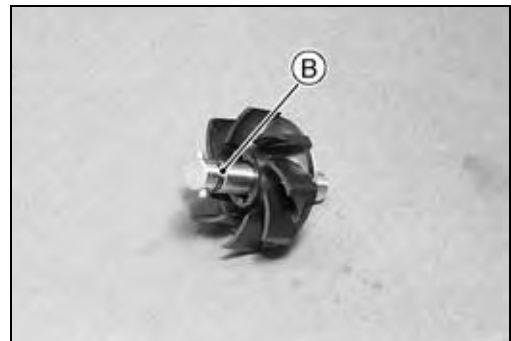
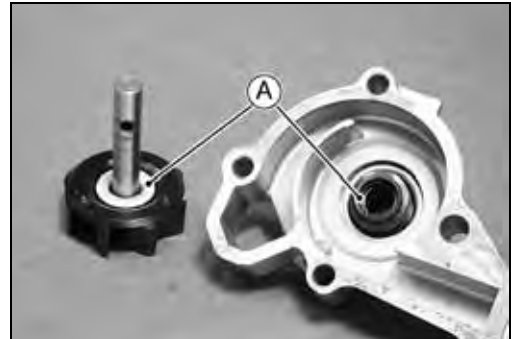

- Measure the diameter [A] of the water pump shaft.
- ★ If the shaft has worn past the service limit, replace the shaft with a new one.

#### **Water Pump Shaft Diameter**

**Standard:** 9.975 ~ 9.990 mm (0.392 ~ 0.393 in.)

**Service Limit:** 9.94 mm (0.39 in.)



- Measure the inside diameter [A] of the water pump shaft bearing.

- ★ If the bearing has worn past the service limit, replace the crankcase with a new one.

#### **Water Pump Shaft Bearing Inside Diameter**

**Standard:** 10.020 ~ 10.038 mm (0.394 ~ 0.395 in.)

**Service Limit:** 10.09 mm (0.40 in.)



**Radiator and Radiator Fan**

*Radiator Removal*

**⚠ WARNING**  
 The radiator fan is connected directly to the battery. The radiator fan may start even if the ignition switch is off. **NEVER TOUCH THE RADIATOR FAN UNTIL THE RADIATOR FAN CONNECTOR IS DISCONNECTED. TOUCHING THE FAN BEFORE THE CONNECTOR IS DISCONNECTED COULD CAUSE INJURY FROM THE FAN BLADES.**

- Remove:  
 Front Cover (see Frame chapter)  
 Coolant (drain)  
 Water Hoses [A]



- Remove:  
 Water Hose [A]  
 Radiator Fan Switch Wires [B]  
 Fan Motor Wire Connector



- Remove:  
 Radiator Mounting Bolts [A]  
 Radiator [B]

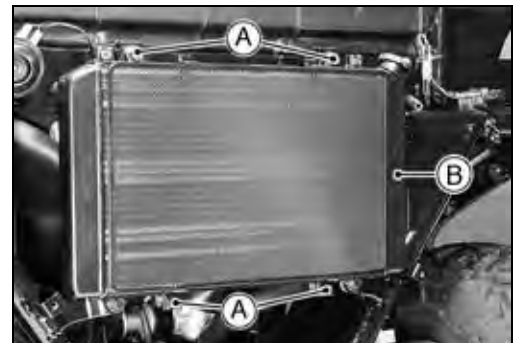

**CAUTION**  
 Do not touch the radiator core. This could damage the radiator fins, resulting in loss of cooling efficiency.

## 4-14 COOLING SYSTEM

### Radiator and Radiator Fan

#### *Radiator Inspection*

- Check the radiator core.
- ★ If there are obstructions to air flow, remove them.
- ★ If the corrugated fins [A] are deformed, carefully straighten them.
- ★ If the air passages of the radiator core are blocked more than 20% by unremovable obstructions or irreparable deformed fins, replace the radiator with a new one.

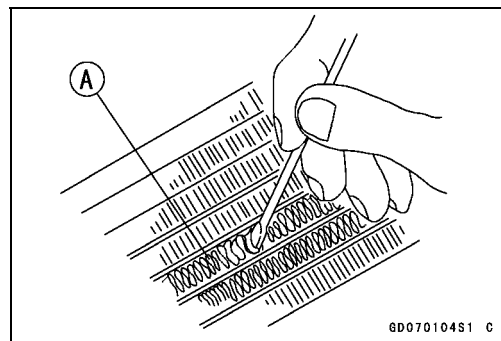

#### *Radiator Cleaning*

- Refer to Radiator Cleaning in the Periodic Maintenance chapter.

## Radiator Cap

The radiator cap at the reservoir tank has the pressure relief valve, and must be inspected. The cap at the radiator has no valve.

### CAUTION

**Do not change the positions of the radiator cap at the reservoir tank and the cap at the radiator.**

### Radiator Cap Inspection

- Check the radiator cap valve seals [A] and valve spring [B].
- ★ If any one of them shows visible damage, replace the cap.

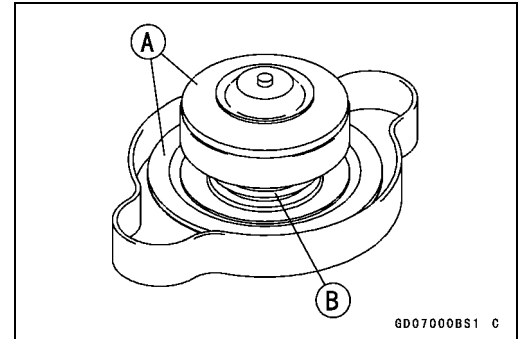

- Install the cap [A] on a cooling system pressure tester [B].

### NOTE

○ *Wet the cap sealing surfaces with water or coolant to prevent pressure leakage.*

- Watching the pressure gauge, slowly pump the pressure tester to build up the pressure. The gauge pointer must remain within the relief pressure range in the table below at least 6 seconds. Continue to pump the tester until the relief valve opens, indicated by the gauge pointer flicks downward. The relief valve must open within the specified range.

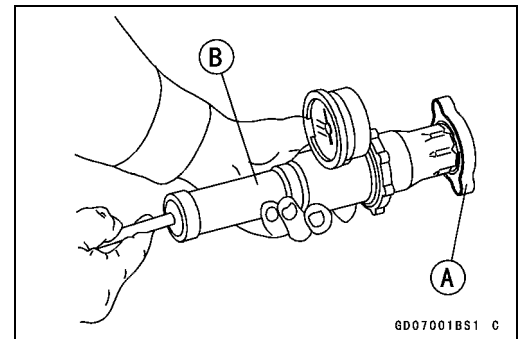

### Radiator Cap Relief Pressure

**Standard: 93 ~ 123 kPa (0.95 ~ 1.25 kgf/cm<sup>2</sup>, 14 ~ 18 psi) for 6 seconds**

- ★ If the cap cannot hold the specified pressure, or if it holds too much pressure, replace it with a new one.

## 4-16 COOLING SYSTEM

### Thermostat

#### *Thermostat Removal*

- Remove:
  - Coolant (drain)
  - Hose [A]



- Remove:
  - Thermostat Housing Cap Bolts [A]
  - Thermostat Housing Cap [B]

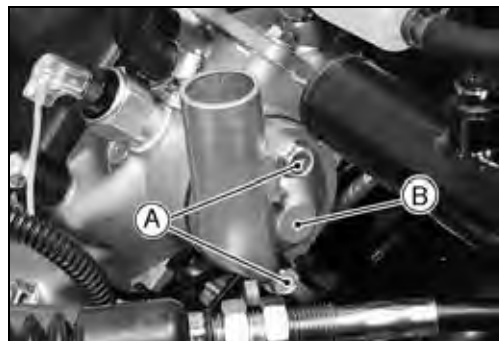

#### *Thermostat Installation*

- Install the thermostat [A] so that the jiggle valve [B] is on top.
- Adjust:
  - Coolant

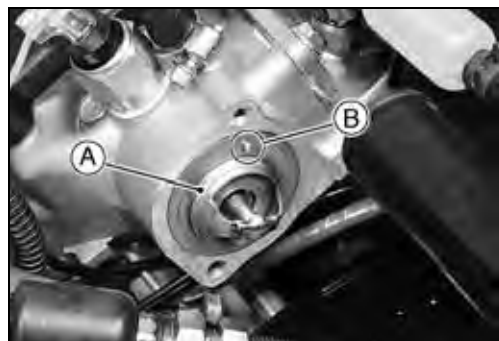

#### *Thermostat Inspection*

- Remove the thermostat, and inspect the thermostat valve [A] at room temperature.
- ★ If the valve is open, replace the valve with a new one.

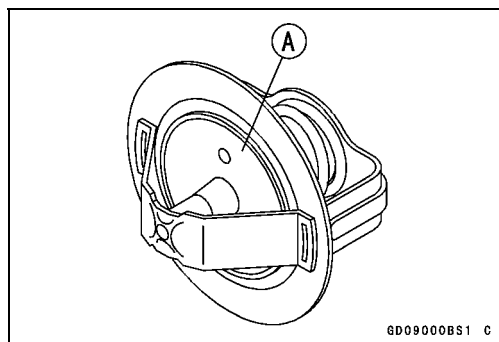

## Thermostat

- To check valve opening temperature, suspend the thermostat in a container of water and raise the temperature of the water.
- ★ If the measurement is out of the specified range, replace the thermostat.

### Thermostat Valve Opening Temperature

Standard: 80.5 ~ 83.5°C (177 ~ 182°F)

- The thermostat [A] must be completely submerged and must not touch the container sides or bottom. Suspend an accurate thermometer [B] in the coolant so that the sensitive portions [C] are located in almost the same depth. It must not touch the container, either.

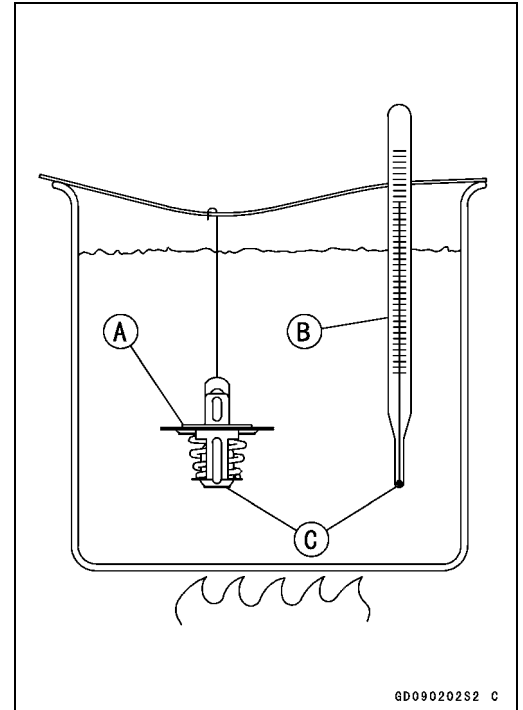

## 4-18 COOLING SYSTEM

### Hoses and Pipes

#### *Hose and Pipe Installation*

- Install the hoses and pipes being careful to follow bending direction or diameter. Avoid sharp bending, kinking, flattening, or twisting.
- Install the clamps [A] as near as possible to the hose end to clear the raised rib or the fitting. This will prevent the hoses from working loose.
- The clamp screws should be positioned correctly to prevent the clamps from contacting anything.

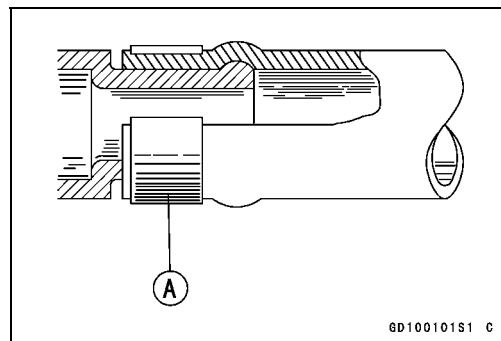

#### *Hose Inspection*

- Visually inspect the hoses for signs of deterioration. Squeeze the hoses. A hose should not be hard and brittle, nor should it be soft or swollen.
- Replace any damaged hoses.



**Radiator Fan Switch, Coolant Temperature Warning Light Switch**

*Radiator Fan Switch, Coolant Temperature Warning Light Switch Removal*

<b>CAUTION</b>
<b>The fan switch or the coolant temperature warning light switch should never be allowed to fall on a hard surface. Such a shock to their parts can damage them.</b>

- Drain the coolant (see Coolant Draining).
- Remove:
  - Radiator Fan Switch Wire Connectors [A]
  - Radiator Fan Switch [B]
  
  - Coolant Temperature Warning Light Switch Wire Connector [A]
  - Coolant Temperature Warning Light Switch [B]

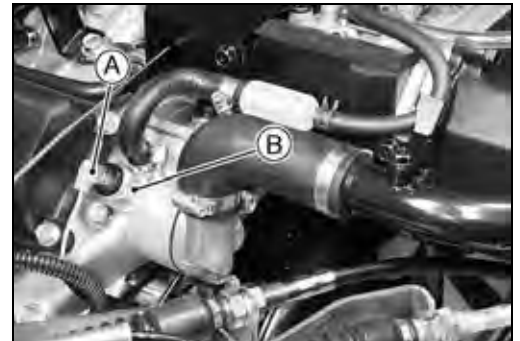
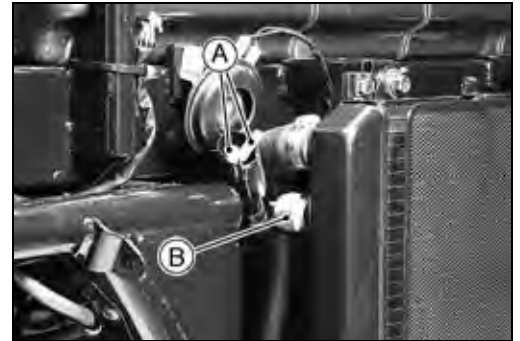

*Radiator Fan Switch, Coolant Temperature Warning Light Switch Installation*

- Apply silicone sealant to the threads of the coolant temperature warning light switch.
  - Sealant - Kawasaki Bond (Silicone Sealant): 56019-120**
- Apply grease to the O-ring of the radiator fan switch.
- Tighten the fan switch and coolant temperature warning light switch.
  - Torque - Radiator Fan Switch: 25 N·m (2.5 kgf·m, 18 ft·lb)**
  - Coolant Temperature Warning Light Switch: 23 N·m (2.3 kgf·m, 17 ft·lb)**

*Radiator Fan Switch, Coolant Temperature Warning Light Switch Inspection*

- Refer to Electrical System chapter for these inspections.



# Engine Top End

## Table of Contents

Exploded View .....	5-2
Specifications .....	5-4
Special Tools .....	5-5
Cylinder Head .....	5-6
Cylinder Compression Measurement.....	5-6
Cylinder Head Removal .....	5-6
Cylinder Head Installation .....	5-8
Cylinder Head Disassembly and Assembly (Valve Mechanism Removal and Installation).....	5-9
Cylinder Head Warp.....	5-10
Valves .....	5-11
Valve Clearance Inspection .....	5-11
Valve Clearance Adjustment.....	5-11
Valve Seat Inspection .....	5-11
Valve Seat Repair .....	5-11
Valve Spring Free Length .....	5-15
Valve Head Thickness .....	5-15
Valve Stem Bend .....	5-15
Valve Stem Diameter .....	5-15
Valve Guide Inside Diameter .....	5-16
Measuring Valve/Guide Clearance (Wobble Method).....	5-16
Rocker Arm/Shaft Wear .....	5-16
Rocker Arm Push Rod Inspection.....	5-17
Exhaust Pipe and Muffler .....	5-18
Exhaust Pipe Removal.....	5-18
Muffler Removal.....	5-18
Exhaust Pipe and Muffler Installation.....	5-18
Exhaust Pipe and Muffler Inspection .....	5-19
Spark Arrester Cleaning.....	5-19

# 5-2 ENGINE TOP END

## Exploded View

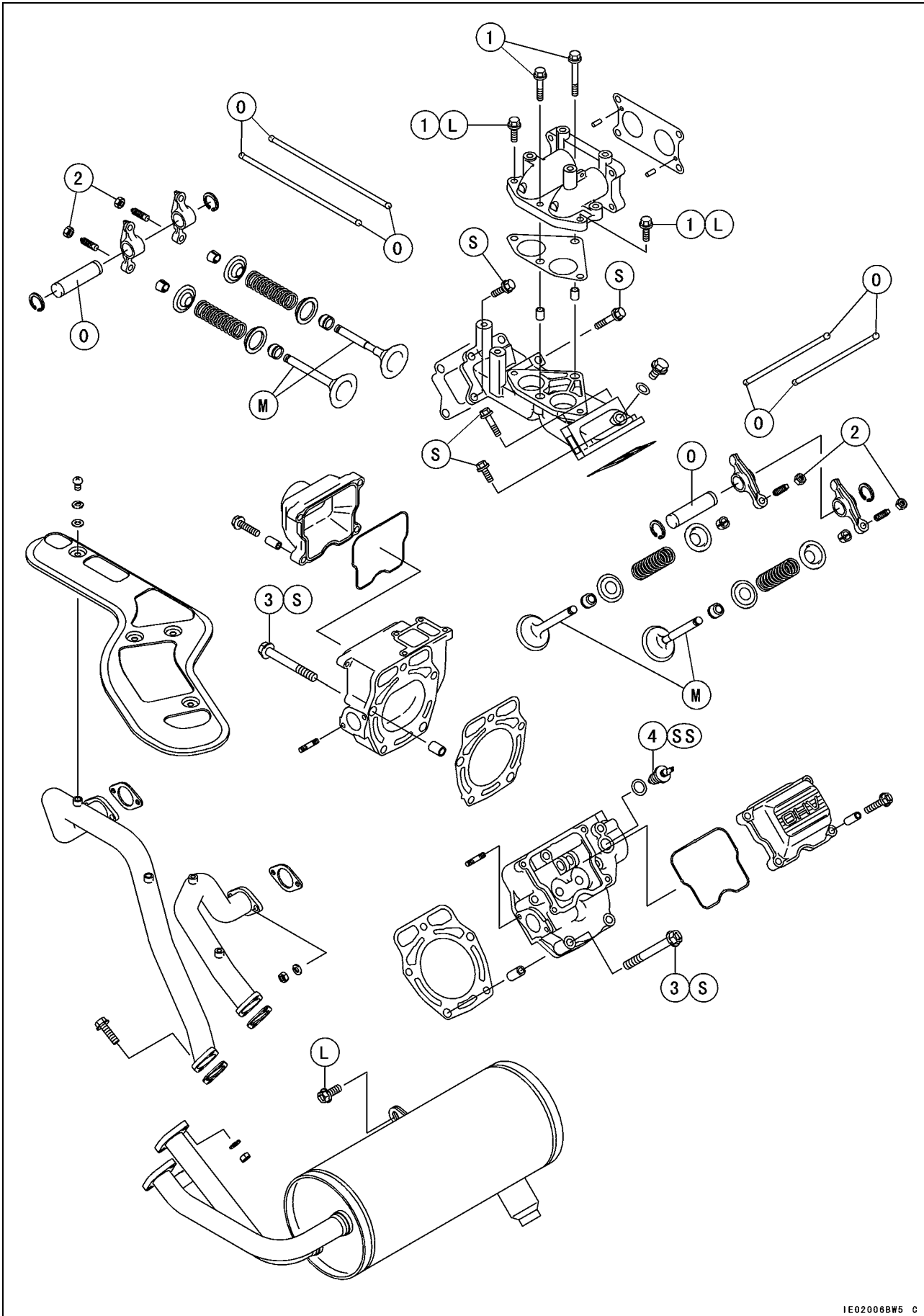

1E02006BW5 C

**Exploded View**

No.	Fastener	Torque			Remarks
		N·m	kgf·m	ft·lb	
1	Intake Pipe Bolts	8.8	0.90	78 in·lb	L (2)
2	Valve Adjusting Screw Locknuts	9.8	1.0	87 in·lb	
3	Cylinder Head Bolts	22	2.2	16	S
4	Coolant Temperature Warning Light Switch	23	2.3	17	SS

L: Apply a non-permanent locking agent.

M: Apply molybdenum disulfide grease.

O: Apply engine oil.

S: Follow specified tightening sequence.

SS: Apply silicone sealant.

## 5-4 ENGINE TOP END

### Specifications

Item	Standard	Service Limit
<b>Cylinder Head</b>		
Cylinder compression	(Usable Range) 1 000 ~ 1 520 kPa (10.2 ~ 15.5 kgf/cm <sup>2</sup> , 145 ~ 220 psi) @490 r/min (rpm)	— — —
Cylinder head warp	— — —	0.03 mm (0.001 in.)
<b>Valves</b>		
Valve clearance (when cold)	0.25 mm (0.010 in.)	— — —
Valve seating surface:		
Outside diameter:		
Inlet	29.5 mm (1.16 in.)	— — —
Exhaust	25.5 mm (1.00 in.)	— — —
Width	0.5 ~ 1.1 mm (0.02 ~ 0.04 in.)	— — —
Valve seat cutting angle	45°	— — —
Valve spring free length	34.3 mm (1.35 in.)	32.6 mm (1.28 in.)
Valve head thickness	0.85 mm (0.03 in.)	0.4 mm (0.02 in.)
Valve stem bend	Less than 0.01 mm (0.0004 in.) TIR	0.05 mm (0.0020 in.) TIR
Valve stem diameter:		
Inlet	5.960 ~ 5.975 mm (0.2346 ~ 0.2352 in.)	5.95 mm (0.2342 in.)
Exhaust	5.950 ~ 5.965 mm (0.2342 ~ 0.2348 in.)	5.94 mm (0.2338 in.)
Valve guide inside diameter	6.000 ~ 6.015 mm (0.2362 ~ 0.2368 in.)	6.08 mm (0.239 in.)
Valve/guide clearance (wobble method):		
Inlet	0.06 ~ 0.12 mm (0.0024 ~ 0.0047 in.)	0.23 mm (0.009 in.)
Exhaust	0.08 ~ 0.14 mm (0.0031 ~ 0.0055 in.)	0.25 mm (0.010 in.)
Rocker shaft diameter	11.989 ~ 12.000 mm (0.4720 ~ 0.4724 in.)	11.95 mm (0.470 in.)
Rocker arm inside diameter	12.006 ~ 12.024 mm (0.4727 ~ 0.4734 in.)	12.05 mm (0.474 in.)
Rocker arm push rod runout	Less than 0.5 mm (0.02 in.) TIR	0.8 mm (0.03 in.) TIR

Special Tools

Outside Circlip Pliers:  
57001-144

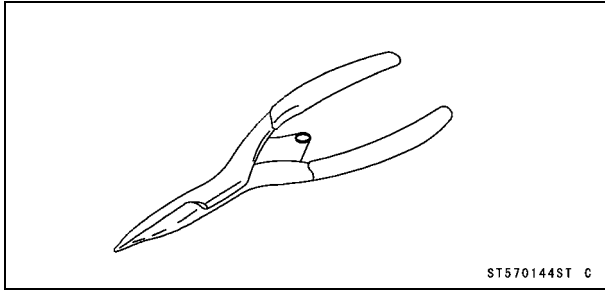

ST570144ST C

Valve Seat Cutter, 45° -  $\phi$ 30:  
57001-1187

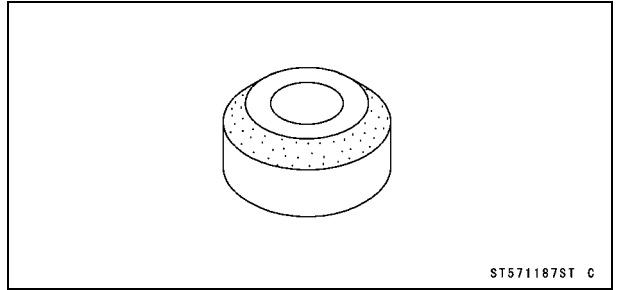

ST571187ST C

Valve Seat Cutter, 45° -  $\phi$ 35:  
57001-1116

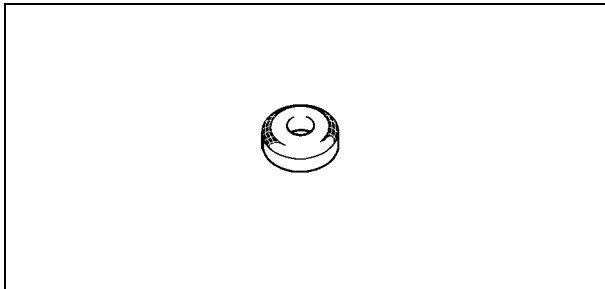

Valve Seat Cutter, 32° -  $\phi$ 33:  
57001-1199

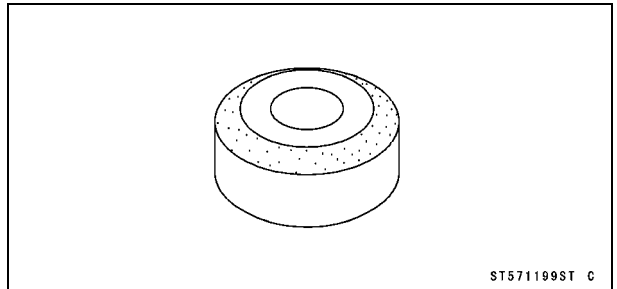

ST571199ST C

Valve Seat Cutter, 32° -  $\phi$ 30:  
57001-1120

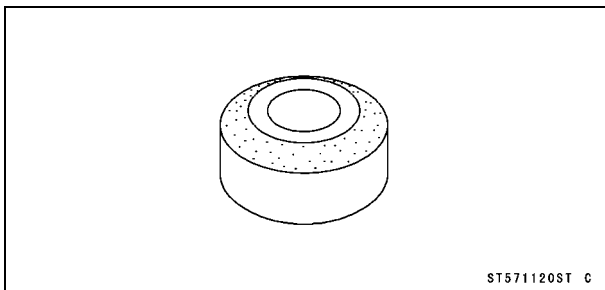

ST571120ST C

Valve Adjusting Screw Holder:  
57001-1217

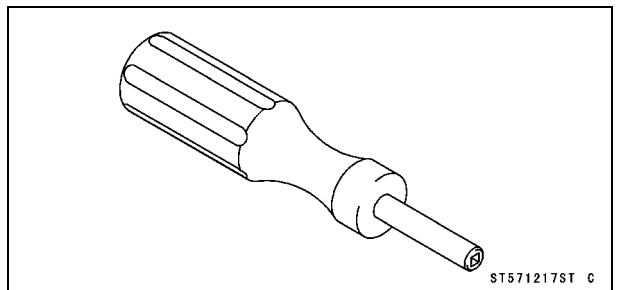

ST571217ST C

Valve Seat Cutter Holder Bar:  
57001-1128

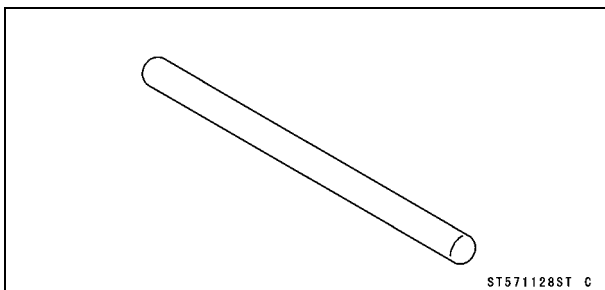

ST571128ST C

Valve Seat Cutter Holder,  $\phi$ 6:  
57001-1360

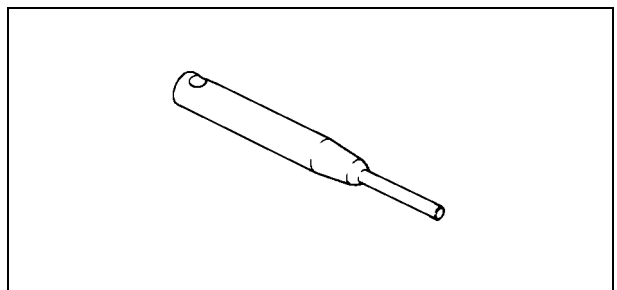

## 5-6 ENGINE TOP END

### Cylinder Head

#### Cylinder Compression Measurement

- Tilt up the cargo bed.
- Thoroughly warm up the engine so that the engine oil between the piston and the cylinder wall will help seal compression as it does during normal running.
- Stop the engine, remove the spark plugs, and attach a compression gauge [A] firmly into the one spark plug hole.
- Using the starter motor, turn the engine over with the throttle fully open until the compression gauge stops rising; this is the highest compression reading obtainable.



#### Cylinder Compression

**Usable Range:** 1 000 ~ 1 520 kPa (10.2 ~ 15.5 kgf/cm<sup>2</sup>, 145 ~ 220 psi) @490 r/min (rpm)

- Repeat the measurement to the other cylinder.

The following table should be consulted if the obtainable compression reading is not within the usable range.

Problem	Diagnosis	Remedy (Action)
Cylinder compression higher than usable range	Carbon accumulation on piston and cylinder head, and in combustion chamber possibly due to damaged valve stem oil seal and/or damaged piston oil rings	Remove the carbon deposits and replace damaged parts if necessary.
	Incorrect cylinder head gasket thickness	Replace with a gasket of the proper thickness.
Cylinder compression lower than usable range	Gas leakage around cylinder head	Replace damaged gasket and check cylinder head warp.
	Bad condition of valve seating	Repair if possible.
	Incorrect valve, piston/cylinder clearance	Adjust.
	Piston seizure	Inspect cylinder and liner and replace/repair as necessary.
	Bad condition of piston ring and/or piston ring grooves	Replace.

#### Cylinder Head Removal

- Remove:
  - Cargo Bed
  - Coolant (drain)
  - Carburetor
  - Choke Cable End [A]
  - Intake Pipe Bolts [B]
  - Intake Pipe [C]





## Cylinder Head

- Remove:

- Choke Cable Bracket Bolt [A]
- Choke Cable Bracket [B]
- Breather Hose [C]
- Coolant Hose [D]

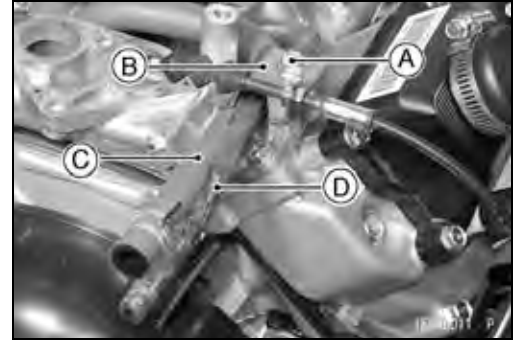

- Remove:

- Bands [A]
- Intake Manifold Bolts [B]
- Intake Manifold [C]
- Muffler and Exhaust Pipe
- Alternator Cover [D]

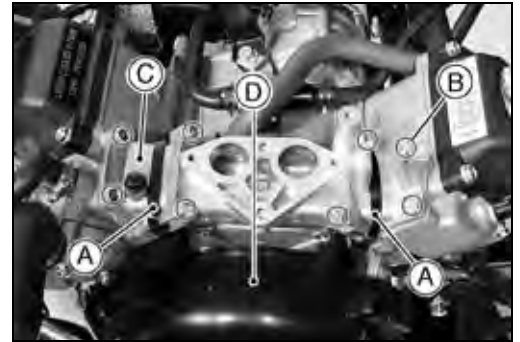

- Remove:

- Hoses [A]
- Coolant Temperature Warning Light Switch Wire [B]
- Spark Plug Cap [C]
- Cylinder Head Cover Bolts [D]
- Cylinder Head Cover [E]
- Thermostat

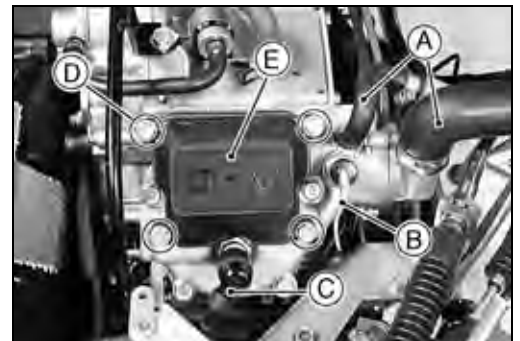

- Remove the coolant from the cylinder head, using a syringe [A] or some other suitable device, through the coolant inlet opening [B].

○ Insert the gauge tube [C] 10 ~ 11 cm (3.9 ~ 4.3 in.) from the opening.

○ Pull the handle slowly to pump out the coolant until the coolant no longer comes out.

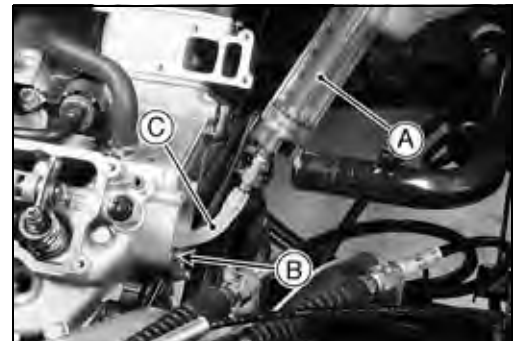

- Turn the alternator rotor clockwise so that the mark "R" [A] on the rotor aligns with the mark [B] on the crankcase breather cover. Check the rocker arms are free. If not, turn the rotor more one turn and free the rocker arms.



## 5-8 ENGINE TOP END

### Cylinder Head

- Remove:
  - Cylinder Head Bolts [A]
  - Cylinder Head [B]
  - Cylinder Head Gasket
  - Rocker Arm Push Rods

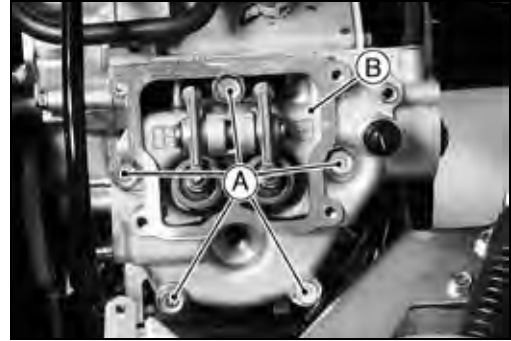

#### *Cylinder Head Installation*

- Clean the mating surface of the cylinder head and the cylinder.
- Replace the gasket with a new one.
- Check to see that the cylinder head knock pins [A] are in place on the cylinder.



- Install the rocker arm push rods.
- Turn the alternator rotor clockwise so that the mark "R" [A] on the rotor aligns with the mark [B] on the crankcase breather cover.



- To install the push rod in a correct position on the tappet, insert the push rod [A] so that the end of the push rod is sliding down along inside wall [B] of the crankcase and position the push rod end on to the tappet [C].
- Check both inlet and exhaust push rods on each cylinder are lowest position [D] on the cam lobes. If not, turn the alternator rotor clockwise more one turn and align both marks on the rotor and breather cover again.
- Be sure the end of the push rods are correctly seated on the tappets.

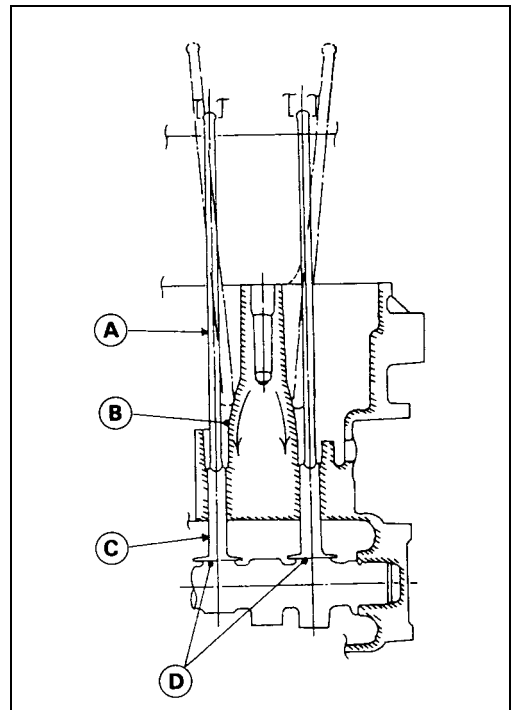

**Cylinder Head**

- Tighten the cylinder head bolts in the order shown.  
**Torque - Cylinder Head Bolts: 22 N-m (2.2 kgf-m, 16 ft-lb)**

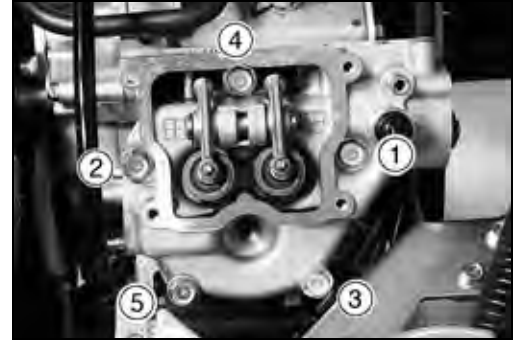

- Tighten the intake manifold bolts in the order shown.
- Adjust:  
 Valve Clearance Adjustment

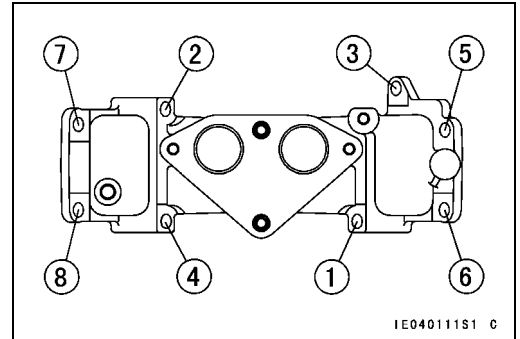

- Route the electric wires [A], and tighten the bands [B] as shown.

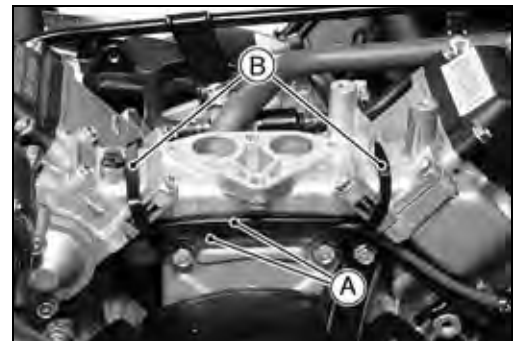

- Replace the gasket with a new one.
- Check to see that the knock pins [A] are in place on the intake manifold.
- Apply a non-permanent locking agent:  
 Two Intake Pipe Bolts [B]
- Tighten:  
**Torque - Intake Pipe Bolts : 8.8 N-m (0.90 kgf-m, 78 in-lb)**

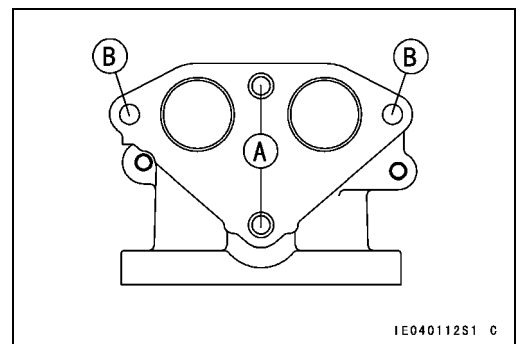

*Cylinder Head Disassembly and Assembly  
 (Valve Mechanism Removal and Installation)*

- Remove:  
 Circlips [A]  
 Rocker Shaft [B]  
 Rocker Arms [C]
- **Special Tool - Outside Circlip Pliers: 57001-144**

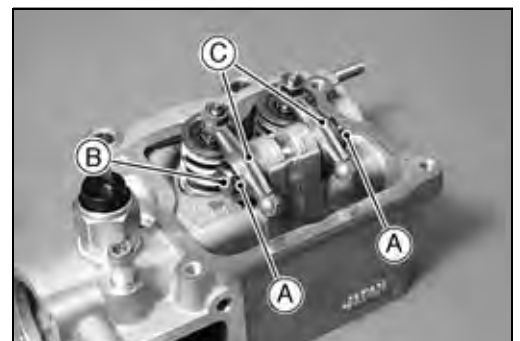

## 5-10 ENGINE TOP END

### Cylinder Head

- Remove:
  - Valve Spring Retainers [A]
  - Split Keepers [B]
  - Valve Springs
  - Valves
- Press down the valve spring retainer holding the valve head, and remove the split keepers.

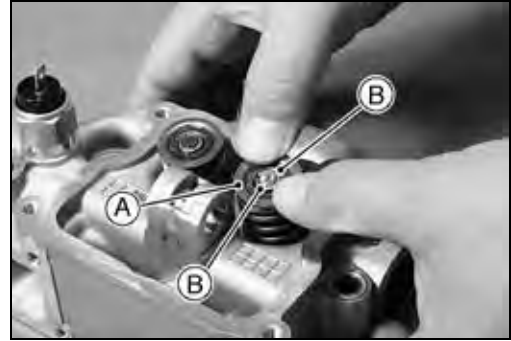

- Remove:
  - Oil Seals [A]
  - Spring Seats [B]

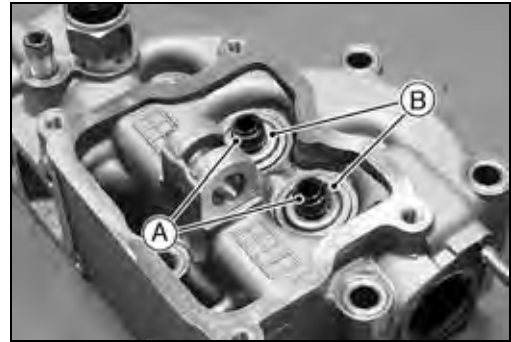

- Check to see that the valve moves smoothly up and down in the guide.
- Check to see that the valve seats properly in the valve seat. If it does not, repair the valve seat.
- Apply engine oil:
  - Valve Stems
  - Rocker Shaft

#### *Cylinder Head Warp*

- Lay a straightedge [A] across the lower surface of the head at several different points, and measure warp by inserting a thickness gauge [B] between the straightedge and the head.
- ★ If warp exceeds the service limit, repair the mating surface. Replace the cylinder head if the mating surface is badly damaged.

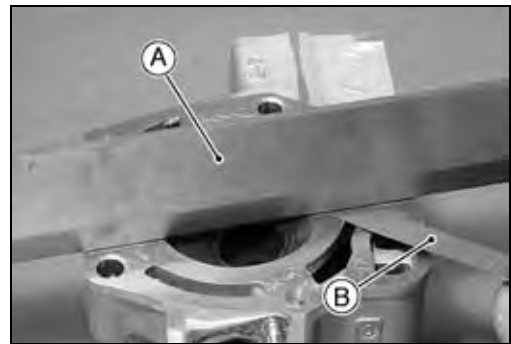

#### **Cylinder Head Warp**

**Service Limit: 0.03 mm (0.001 in.)**

## Valves

### Valve Clearance Inspection

- Refer to Valve Clearance Inspection in the Periodic Maintenance chapter

### Valve Clearance Adjustment

- Refer to Valve Clearance Adjustment in the Periodic Maintenance chapter

### Valve Seat Inspection

- Remove the valve.
- Check the valve seating surface [A] between the valve [B] and valve seat [C].
- Coat the valve seat with machinist's dye.
- Push the valve into the guide.
- Rotate the valve against the seat with a lapping tool.
- Pull the valve out, and check the seating pattern on the valve head. It must be the correct width [A] and even all the way around.

#### NOTE

○ The valve stem and guide must be in good condition, or this check will not be valid.

- ★ If the valve seating pattern is not correct, repair the seat.
- Measure the outside diameter [D] of the seating pattern on the valve seat.
- ★ If the outside diameter of the valve seating pattern is too large or too small, repair the seat.

#### Valve Seating Surface Outside Diameter

**Inlet:** 29.5 mm (1.16 in.)

**Exhaust:** 25.5 mm (1.00 in.)

- Measure the seat width [E] of the portion where there is no build-up carbon (white portion) of the valve seat with a vernier caliper.
  - Good [F]
  - Too Wide [G]
  - Too Narrow [H]
  - Uneven [J]
- ★ If the width is too wide, too narrow or uneven, repair the seat (See Valve Seat Repair).

#### Valve Seating Surface Width

**Standard:** 0.5 ~ 1.1 mm (0.02 ~ 0.04 in.)

### Valve Seat Repair

- Follow the manufacturer's instructions for use of valve seat cutters.

**Special Tools - Valve Seat Cutter, 45° -  $\phi$ 35:** 57001-1116 [IN]

**Valve Seat Cutter, 30° -  $\phi$ 30:** 57001-1120 [EX]

**Valve Seat Cutter, 45° -  $\phi$ 30:** 57001-1187 [EX]

**Valve Seat Cutter, 32° -  $\phi$ 33:** 57001-1199 [IN]

**Valve Seat Cutter Holder,  $\phi$ 6:** 57001-1360

**Valve Seat Cutter Holder Bar:** 57001-1128

- ★ If the manufacturer's instructions are not available, use the following procedure.

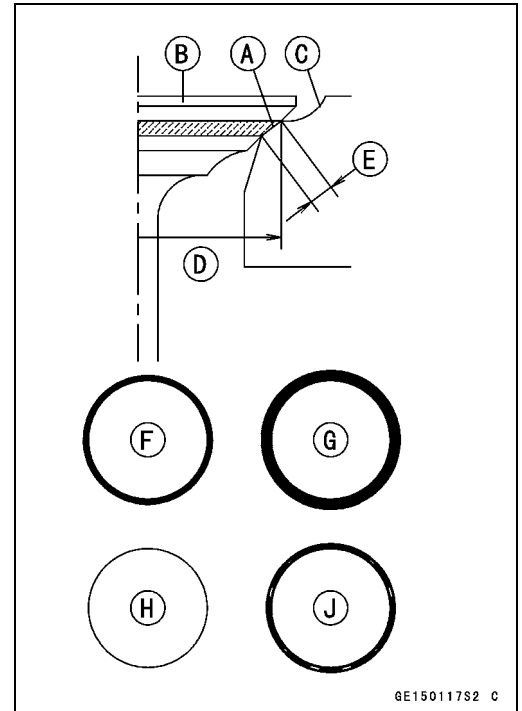

6E150117S2 C

## 5-12 ENGINE TOP END

### Valves

#### Seat Cutter Operating Cares

1. The valve seat cutter [A] is designed only for valve seat repair. Therefore the cutter must not be used for other purposes.
2. Do not drop or hit the valve seat cutter, or the diamond particles may fall off.
3. Do not fail to apply engine oil to the valve seat cutter before grinding the seat surface. Also wash off ground particles sticking to the cutter with washing oil.

**Special Tools - Valve Seat Cutter Holder,  $\phi$ 6: 57001-1360 [B]**

**Valve Seat Cutter Holder Bar: 57001-1128 [C]**

#### NOTE

○Do not use a wire brush to remove the metal particles from the cutter. It will take off the diamond particles.

4. Setting the valve seat cutter holder in position, operate the cutter with one hand. Do not apply too much force to the diamond portion.

#### NOTE

○Prior to grinding, apply oil to the cutter, and during the operation wash off any ground particles sticking to the cutter with washing oil.

5. After use wash the cutter with washing oil and apply a thin layer of engine oil before storing.

#### Marks Stamped on the Cutter

The marks stamped on the back of the cutter [A] represent the following.

**60** ..... Cutter angle [B]

**37.5 $\phi$**  ..... Outer diameter of cutter [C]

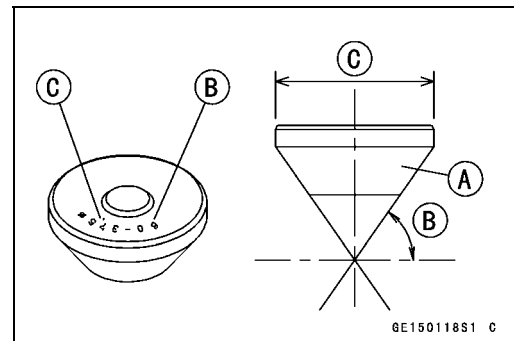
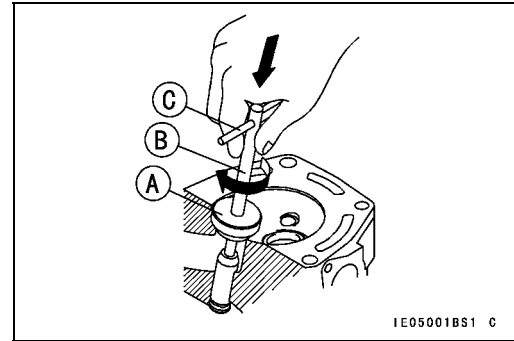

## Valves

### Operating Procedures

- Clean the seat area carefully.
- Coat the seat with machinist's dye.
- Fit a 45° cutter to the holder and slide it into the valve guide.
- Press down lightly on the handle and turn it right or left. Grind the seating surface only until it is smooth.

#### CAUTION

**Do not grind the seat too much. Overgrinding will reduce valve clearance by sinking the valve into the head. If the valve sinks too far into the head, it will be impossible to adjust the clearance, and the cylinder head must be replaced.**

- Measure the outside diameter (O.D.) of the seating surface with a vernier caliper.
- ★ If the O.D. of the seating surface is too small, repeat the 45° grind until the diameter is within the specified range.
- ★ If the O.D. of the seating surface is too large, make the 32° grind described below.
- Grind the seat at a 32° angle until the seat O.D. is within the specified range.
- To make the 32° grind, fit a 32° cutter to the holder, and slide it into the valve guide.
- Turn the holder one turn at a time while pressing down very lightly. Check the seat after each turn.

#### CAUTION

**The 32° cutter removes material very quickly. Check the seat outside diameter frequently to prevent overgrinding.**

- After making the 32° grind, return to the seat O.D. measurement step above.
- Lap the valve to the seat, once the seat width and O.D. are within the ranges specified above.
- Put a little coarse grinding compound on the face of the valve in a number of places around the valve head.
- Spin the valve against the seat until the grinding compound produces a smooth, matched surface on both the seat and the valve.
- Repeat the process with a fine grinding compound.
  - [A] Lapper
  - [B] Valve Seat
  - [C] Valve
- The seating area should be marked about in the middle of the valve face.
- ★ If the seat area is not in the right place on the valve, check to be sure the valve is the correct part. If it is, it may have been refaced too much; replace it.
- Be sure to remove all grinding compound before assembly.
- When the engine is assembled, be sure to adjust the valve clearances (see Valve Clearance Adjustment).

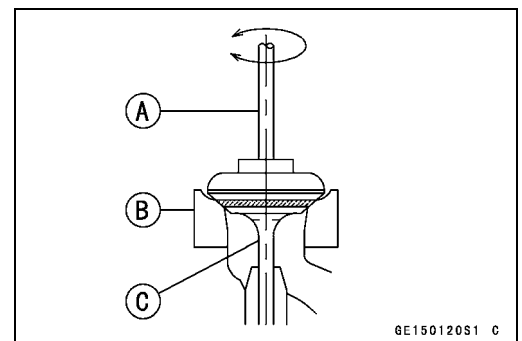

## 5-14 ENGINE TOP END

### Valves

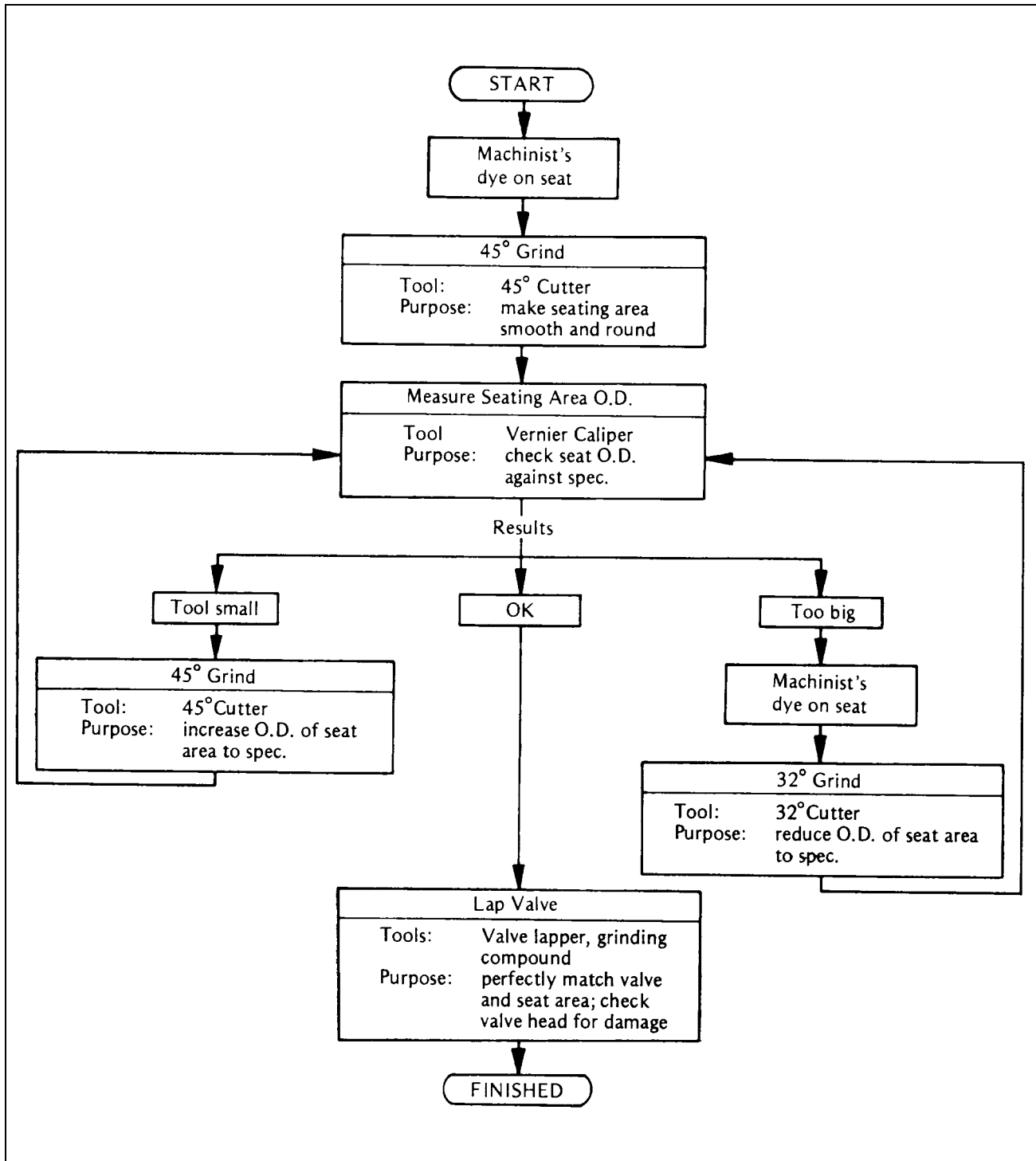



**Valves**

*Valve Spring Free Length*

- Measure the valve spring free length.
- ★ If the free length is less than the service limit, replace the valve spring with a new one.

**Valve Spring Free Length**

**Standard:** 34.3 mm (1.35 in.)  
**Service Limit:** 32.6 mm (1.28 in.)

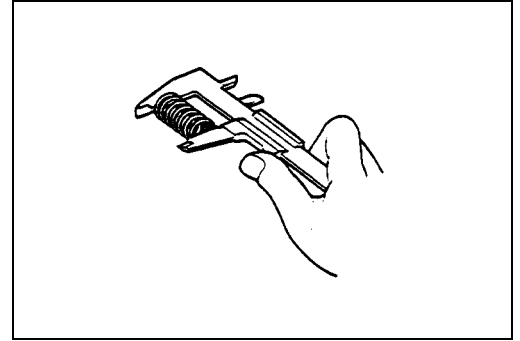

*Valve Head Thickness*

- Measure the thickness [A] of the valve head.
- ★ If the valve head thickness is less than the service limit, replace the valve with a new one.

**Valve Head Thickness**

**Standard:** 0.85 mm (0.03 in.)  
**Service Limit:** 0.4 mm (0.02 in.)

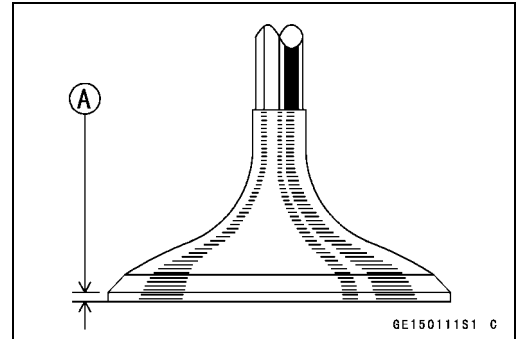

*Valve Stem Bend*

- Place the valve in V blocks at each end of the stem, and set a dial gauge on the stem at a point halfway between the blocks. Turn the valve to measure the bend. The difference between the highest and the lowest dial readings is the amount of bend.
- ★ If the valve stem bend is greater than the service limit, replace the valve with a new one.

**Valve Stem Bend**

**Standard:** Less than 0.01 mm (0.0004 in.) TIR  
**Service Limit:** 0.05 mm (0.0020 in.) TIR

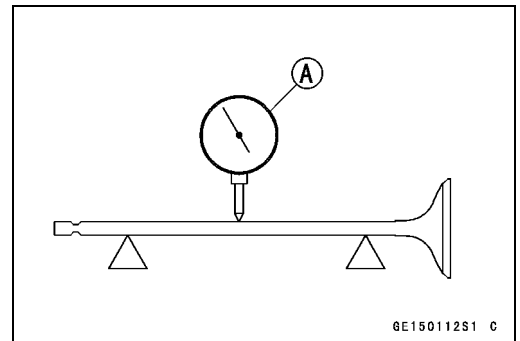

*Valve Stem Diameter*

- Measure the diameter [A] of the valve stem in two directions at right angles, at four different positions on the stem.
- ★ If any single measurement is less than the service limit, replace the valve with a new one.

**Valve Stem Diameter**

**Standard:**

<b>Inlet</b>	<b>5.960 ~ 5.975 mm(0.2346 ~ 0.2352 in.)</b>
<b>Exhaust</b>	<b>5.950 ~ 5.965 mm(0.2342 ~ 0.2348 in.)</b>
<b>Service Limit</b>	
<b>Inlet</b>	<b>5.95 mm(0.2342 in.)</b>
<b>Service Limit</b>	<b>5.94 mm(0.2338 in.)</b>

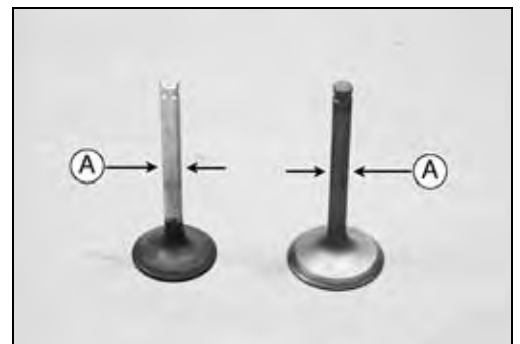

## 5-16 ENGINE TOP END

### Valves

#### Valve Guide Inside Diameter

- Measure the inside diameter [A] of the valve guide.
- ★ If the valve guide has worn past the service limit, replace the cylinder head.

#### Valve Guide Inside Diameter

- Standard:** 6.000 ~ 6.015 mm (0.2362 ~ 0.2368 in.)  
**Service Limit:** 6.08 mm (0.239 in.)

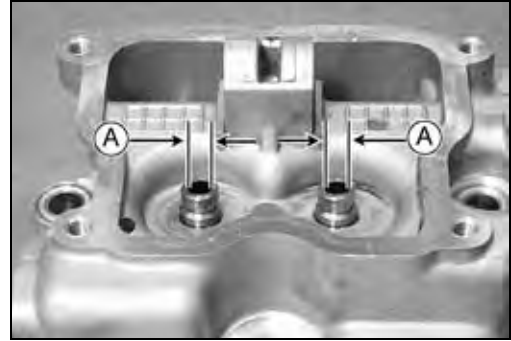

#### Measuring Valve/Guide Clearance (Wobble Method)

If a small bore gauge is not available, inspect the valve guide wear by measuring the valve/guide clearance with the wobble method, as indicated below.

- Insert a new valve [A] into the guide [B] from the top of the head.
- Set a dial gauge against the stem perpendicular to it as close as possible to the cylinder head upper surface.
- Move the stem back and forth [C] to measure valve/guide clearance.
- Repeat the measurement in a direction at a right angle to the first.
- ★ If the reading exceeds the service limit, replace the guide.

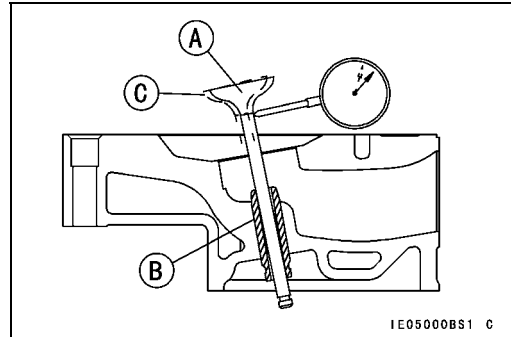

#### NOTE

- The reading is not actual valve/guide clearance because the measuring point is above the guide.

#### Valve/Guide Clearance (Wobble Method)

##### Standard

- Inlet** 0.06 ~ 0.12 mm (0.0024 ~ 0.0047 in.)  
**Exhaust** 0.08 ~ 0.14 mm (0.0031 ~ 0.0055 in.)

##### Service Limit

- Inlet** 0.23 mm (0.009 in.)  
**Exhaust** 0.25 mm (0.010 in.)

#### Rocker Arm/Shaft Wear

- Measure the diameter [A] of the rocker shaft.
- ★ If the shaft has worn past the service limit, replace the rocker shaft with a new one.

#### Rocker Shaft Diameter

- Standard:** 11.989 ~ 12.000 mm (0.4720 ~ 0.4724 in.)  
**Service Limit:** 11.95 mm (0.470 in.)

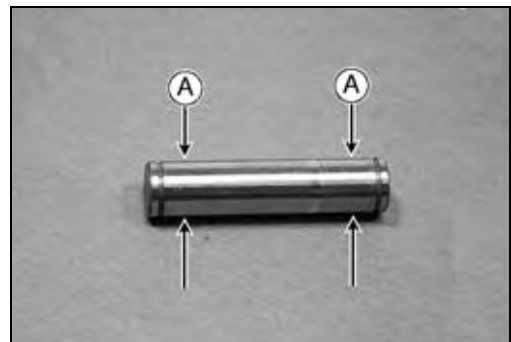

## Valves

- Measure the inside diameter [A] of the rocker arm.
- ★ If the bearing has worn past the service limit, replace the rocker arm with a new one.

### Rocker Arm Inside Diameter

<b>Standard:</b>	<b>12.006 ~ 12.024 mm (0.4727 ~ 0.4734 in.)</b>
<b>Service Limit:</b>	<b>12.05 mm (0.474 in.)</b>

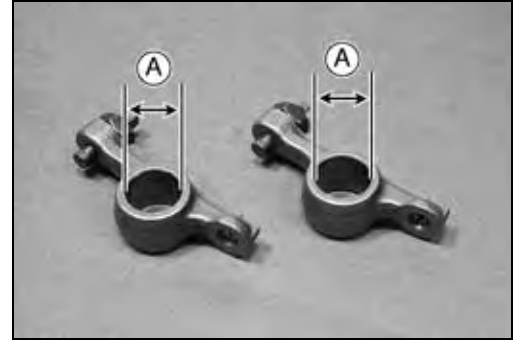

### Rocker Arm Push Rod Inspection

- Place the rocker arm push rod in V blocks that are as far apart as possible, and set a dial gauge on the rod at a point halfway between the blocks. Turn the rod to measure the runout. The difference between the highest and the lowest dial readings is the amount of runout.
- ★ If the runout exceeds the service limit, replace the rod.

### Rocker Arm Push Rod Runout

<b>Standard:</b>	<b>Less than 0.5 mm (0.02 in.) TIR</b>
<b>Service Limit:</b>	<b>0.8 mm (0.03 in.) TIR</b>

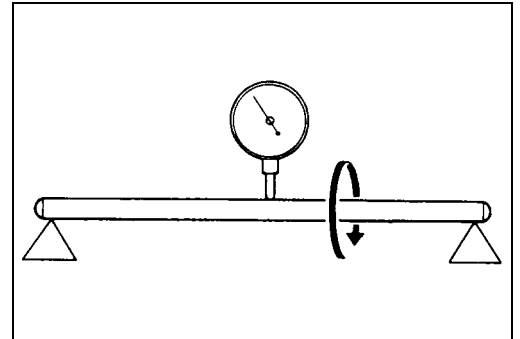

## 5-18 ENGINE TOP END

### Exhaust Pipe and Muffler

#### *Exhaust Pipe Removal*

- Remove:
  - Exhaust Pipe Cover Screws [A]
  - Exhaust Pipe Cover [B]

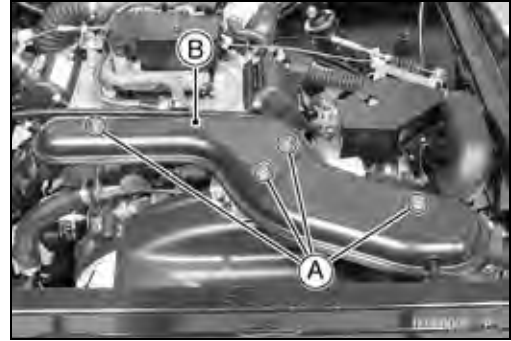

- Remove:
  - Exhaust Pipe Holder Nuts [A]
  - Exhaust Pipe Clamp Bolts [B]
  - Exhaust Pipes [C]

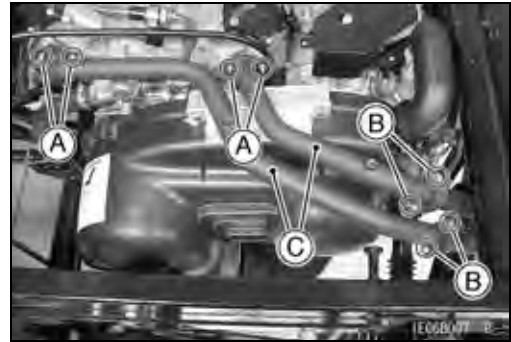

#### *Muffler Removal*

- Remove:
  - Exhaust Pipe Clamp Bolts [A]
  - Muffler Mounting Bolts [B]
  - Muffler [C]

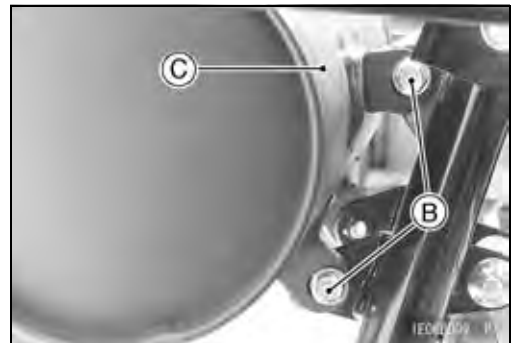
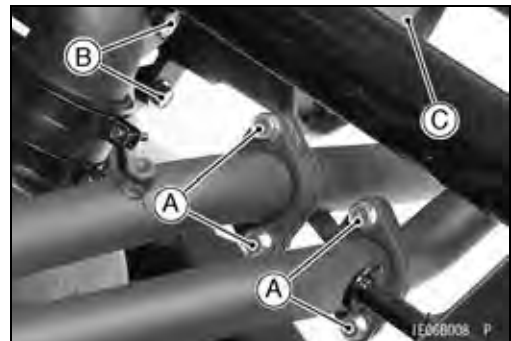

#### *Exhaust Pipe and Muffler Installation*

- Apply a non-permanent locking agent:
  - Muffler Mounting Bolts
- Check the exhaust gasket and the muffler connecting gasket for signs of damage. If necessary, replace them with new ones.
- After installation, thoroughly warm up the engine, wait until the engine cools down, and then retighten the clamp bolt and holder nuts.

---

## Exhaust Pipe and Muffler

---

### *Exhaust Pipe and Muffler Inspection*

- Before removing, check for signs of leakage at the exhaust pipe gasket in the cylinder head and at the muffler clamp.
- ★ If there are signs of leakage around the exhaust pipe gasket, it should be replaced. If the muffler-to-exhaust pipe joint leaks, tighten the clamp.
- Check the exhaust pipe and muffler for dents, cracks, rust and holes.
- ★ If the exhaust pipe or muffler is damaged, it should be replaced for best performance and least noise.

### *Spark Arrester Cleaning*

- Refer to Spark Arrester Cleaning in the Periodic Maintenance chapter.



# Converter System

## Table of Contents

Exploded View .....	6-2
Specifications .....	6-6
Special Tools .....	6-7
Air Cleaner.....	6-8
Air Cleaner Housing Removal.....	6-8
Air Cleaner Element Removal.....	6-8
Air Cleaner Element Cleaning/Inspection .....	6-8
Torque Converter.....	6-9
Torque Converter Removal .....	6-9
Torque Converter Installation .....	6-10
Torque Converter Case Removal.....	6-11
Drive Belt.....	6-12
Drive Belt Removal .....	6-12
Drive Belt Installation .....	6-12
Drive Belt Deflection Inspection .....	6-13
Drive Belt Deflection Adjustment .....	6-13
Drive Belt Inspection .....	6-13
Drive Pulley .....	6-14
Drive Pulley Disassembly .....	6-14
Drive Pulley Assembly .....	6-15
Spider/Wear Guide Clearance Adjustment .....	6-16
Drive Pulley Inspection .....	6-16
Bushing Installation.....	6-18
Driven Pulley .....	6-19
Driven Pulley Disassembly .....	6-19
Driven Pulley Assembly .....	6-20
Driven Pulley Inspection .....	6-21
Bushing Installation.....	6-22

# 6-2 CONVERTER SYSTEM

## Exploded View

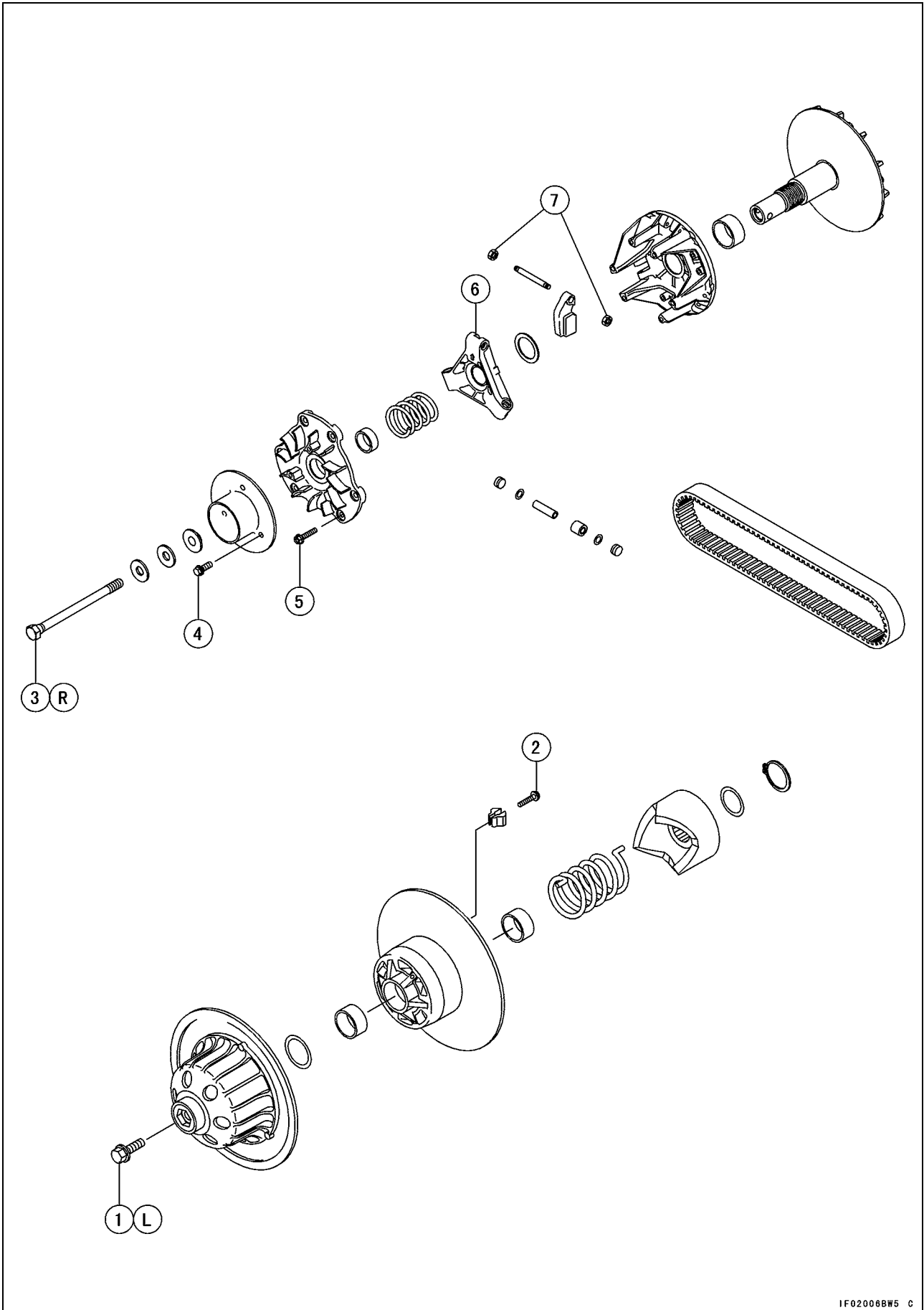

IF02006BW5 C



**Exploded View**

No.	Fastener	Torque			Remarks
		N·m	kgf·m	ft·lb	
1	Driven Pulley Bolt	93	9.5	69	L
2	Wear Shoe Mounting Screws	1.1	0.11	10 in·lb	
3	Drive Pulley Bolt (New)	76	7.7	56	R
4	Cooling Fan Cover Bolts	8.8	0.90	78 in·lb	
5	Drive Pulley Cover Bolts	13	1.3	113 in·lb	
6	Spider	275	28	203	
7	Ramp Weight Nuts	6.9	0.70	61 in·lb	

L: Apply a non-permanent locking agent.

R: Replacement Part

# 6-4 CONVERTER SYSTEM

## Exploded View

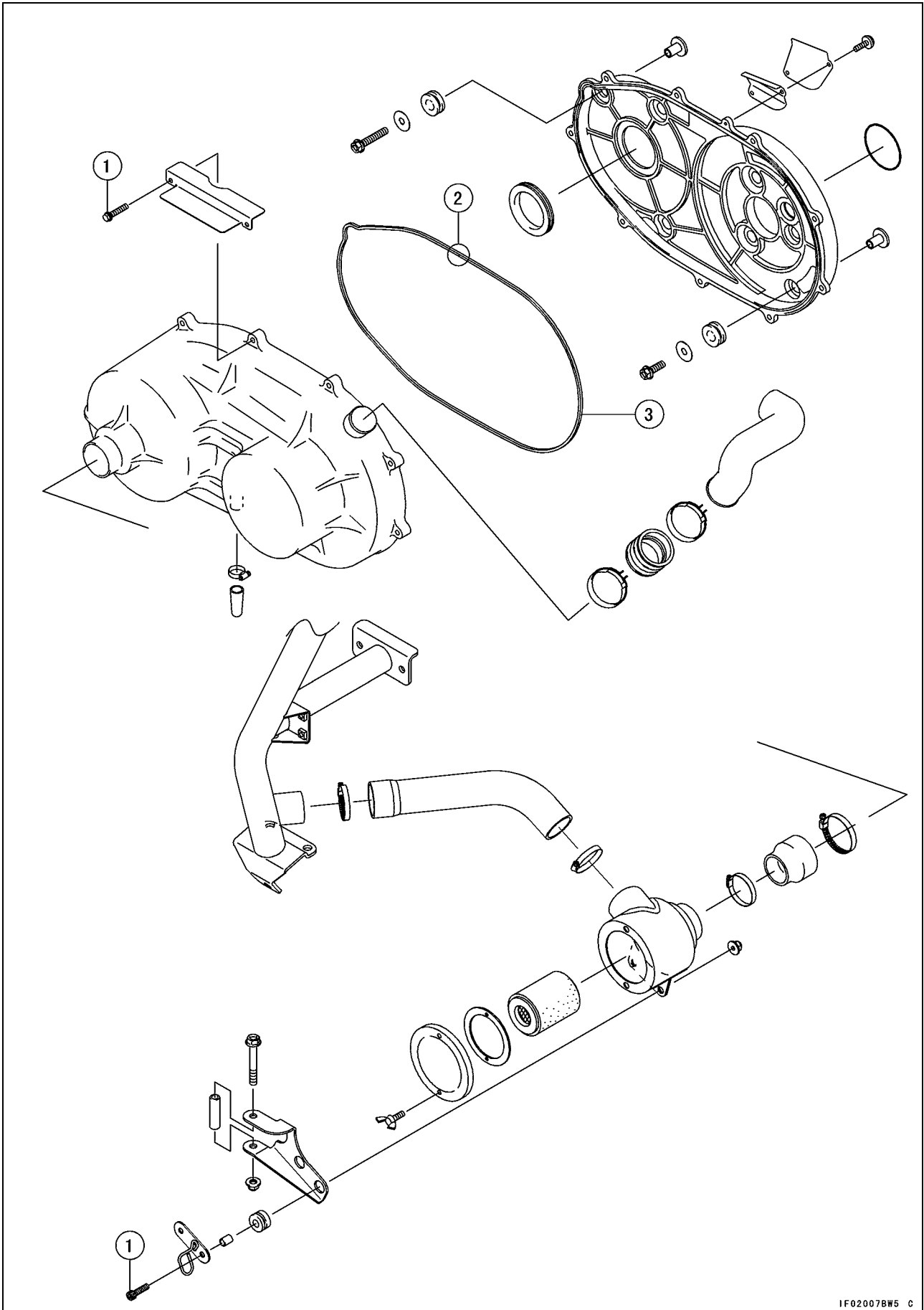

**Exploded View**

No.	Fastener	Torque			Remarks
		N·m	kgf·m	ft·lb	
1	Converter Cover Bolts	1.5	0.15	13 in·lb	

2. Fit the joint location of the seal with the top of the case.
3. Fit the seal into groove of the case. Do not twist the seal.

## 6-6 CONVERTER SYSTEM

### Specifications

Item	Standard	Service Limit
<b>Drive Belt</b>		
Belt Deflection	28 ~ 33 mm (1.1 ~ 1.3 in.)	---
Belt Width	30.3 mm (1.19 in.)	28.8 mm (1.13 in.)
<b>Drive Pulley</b>		
Spider Wear Guide Clearance	0 ~ 0.4 mm (0 ~ 0.16 in.)	---
Cover Bushing Inside Diameter	28.075 ~ 28.175 mm (1.105 ~ 1.109 in.)	28.21 mm (1.111 in.)
Sheave Bushing Inside Diameter	38.075 ~ 38.175 mm (1.499 ~ 1.503 in.)	38.21 mm (1.504 in.)
Spider Wear Guide Thickness	7.3 ~ 7.7 mm (0.287 ~ 0.303 in.)	---
Spring Free Length	65.02 mm (2.56 in.)	---
<b>Driven Pulley</b>		
Sheave Bushing Inside Diameter	38.075 ~ 38.175 mm (1.499 ~ 1.503 in.)	38.21 mm (1.504 in.)
Wear Shoe Width	---	16.3 mm (0.64 in.)
Spring Free Length	112.6 mm (4.43 in.)	---

Special Tools

Outside Circlip Pliers:  
57001-144

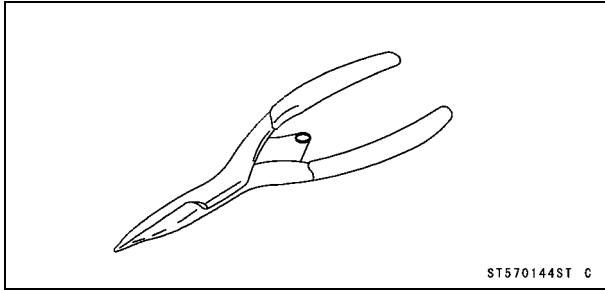

Drive Pulley Puller Bolt:  
57001-1429

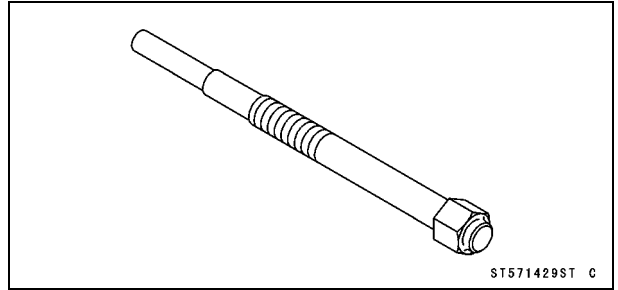

Drive Pulley Wrench:  
57001-1411

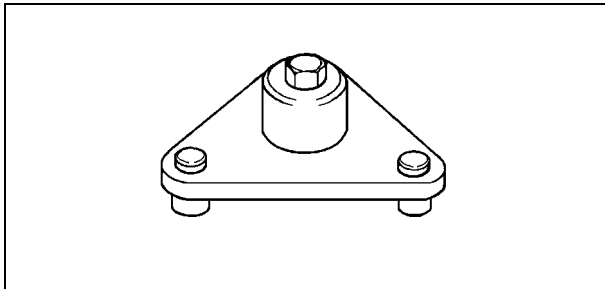

Driven Pulley Holder:  
57001-1465

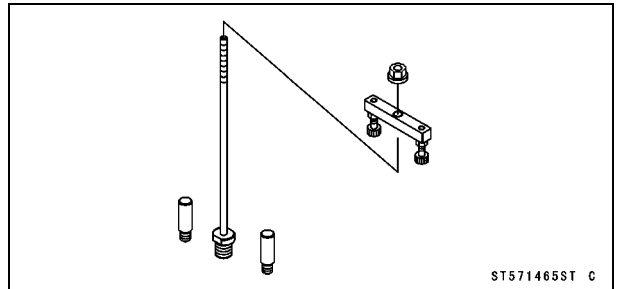

Drive & Driven Pulley Holder:  
57001-1412

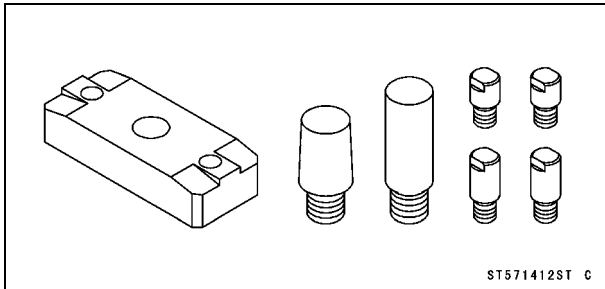

## 6-8 CONVERTER SYSTEM

### Air Cleaner

#### *Air Cleaner Housing Removal*

- Loosen:
  - Clamps [A]
- Remove:
  - Air Duct [B]
  - Bracket Bolt [C], Collar and Nut
  - Air Cleaner Housing [D]
- After removing the housing, stuff pieces of lint-free, clean cloth into the torque converter cover duct to keep dirt out of the torque converter.

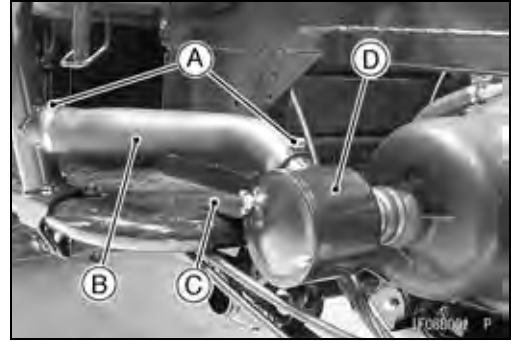

#### **CAUTION**

**If dirt gets into the torque converter, excessive wear and loss of driving power may result.**

#### *Air Cleaner Element Removal*

- Remove:
  - Wingbolts [A]
  - Cap [B]
- Remove:
  - Air Cleaner Element [A]
- After removing the element, stuff pieces of lint-free, clean cloth into the air cleaner duct to keep dirt out of the torque converter.

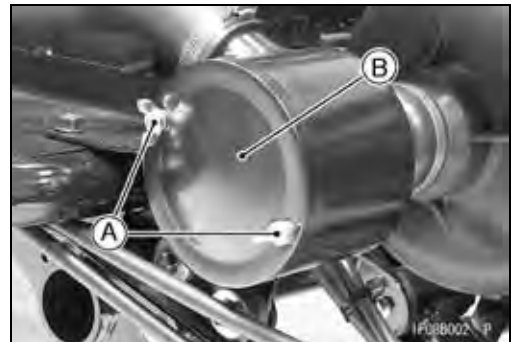

#### **CAUTION**

**If dirt gets into the torque converter, excessive wear and loss of driving power may result.**



#### *Air Cleaner Element Cleaning/Inspection*

- Refer to Air Cleaner Element Cleaning/Inspection in the Periodic Maintenance chapter.

**Torque Converter**

*Torque Converter Removal*

- Remove:
  - Left Rear Shock Absorber [A] (see Suspension chapter)
  - Air Cleaner Housing for Torque Converter (see Air Cleaner Housing Removal)
  - Exhaust Pipe (see Engine Top End chapter)
  - Outer Cover Bolts
  - Torque Converter Cover [B]

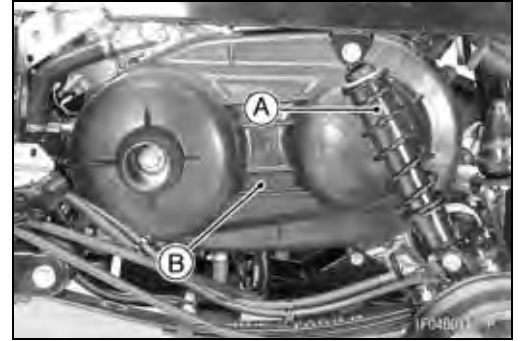

- Remove:
  - Cooling Fan Cover Bolts [A]
  - Cooling Fan Cover [B]
  - Drive Belt (see Drive Belt Removal)



- Using a suitable holder [A], remove the drive pulley bolt [B].



- Using the drive pulley puller bolt [A] and a suitable holder, remove the drive pulley [B] from the crankshaft.
- Special Tool - Drive Pulley Puller Bolt: 57001-1429**

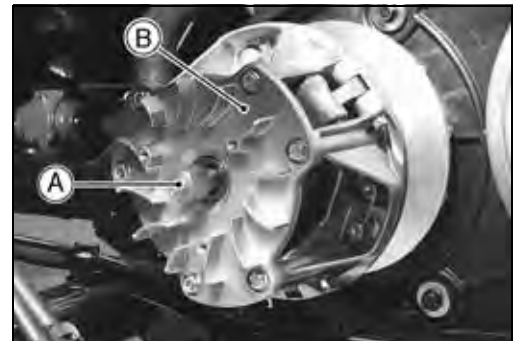

- Using a suitable holder [A], remove the driven pulley bolt [B].
- Remove:
  - Driven Pulley

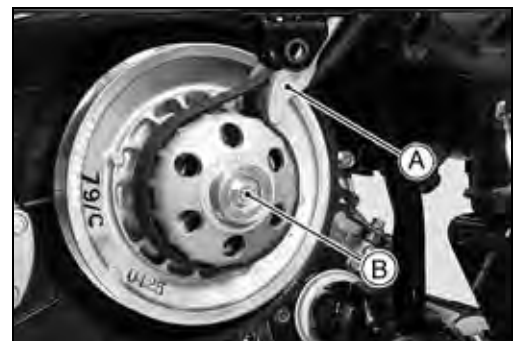

## 6-10 CONVERTER SYSTEM

### Torque Converter

#### Torque Converter Installation

- Clean the following portions with an oil-less cleaning fluid such as trichloroethylene or acetone.
  - Fixed Sheave Tapered Portion [A]
  - Crankshaft Tapered Portion [B]

#### **⚠ WARNING**

**These cleaning fluids are usually highly flammable and harmful if breathed for prolonged periods. Be sure to heed the fluid manufacturer's warnings.**

- Apply molybdenum disulfide grease:
  - Driven Shaft Splines [A]

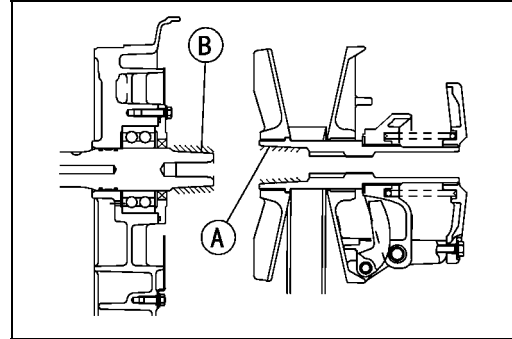

- Install:
  - Drive Pulley [A]
  - Driven Pulley [B]
  - Drive Belt [C] (see Drive Belt Installation)

#### **NOTE**

○ When engaging the spline on the pulleys with the spline on the shafts, do not burr on the pulley's spline. If any burr occur, surely remove it with a file.

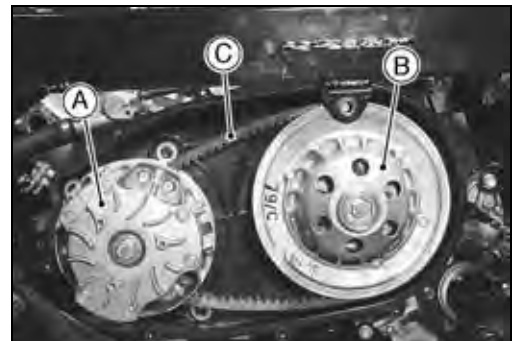

- Replace the drive pulley bolt [A] with a new one.
- Install the washers [B] and spring seat [C] on the drive pulley bolt as shown.

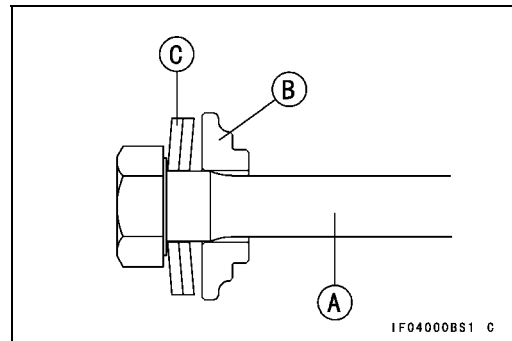

- Apply a non-permanent locking agent:
  - Driven Pulley Bolt
- Tighten:
  - Torque - Drive Pulley Bolt (New): 76 N·m (7.7 kgf·m, 56 ft·lb)
  - Driven Pulley Bolt: 93 N·m (9.5 kgf·m, 69 ft·lb)
  - Cooling Fan Cover Bolts: 8.8 N·m (0.90 kgf·m, 78 in·lb)

1F04000BS1 C



## Torque Converter

- ★ When installing the new trim seal [A], install it according to the following procedure.
- Fit the joint [B] of the trim seal with the top of the case [C].
- Fit the seal into the groove of the case.

### NOTE

○ Do not twist the trim seal.

- Tighten:

**Torque - Converter Cover Bolts: 1.5 N·m (0.15 kgf·m, 13 in·lb)**

### Torque Converter Case Removal

- Remove:
  - Left Rear Wheel
  - Drive Pulley, Driven Pulley and Drive Belt (see Drive and Driven Pulley Removal)
  - Torque Converter Case Bolts [A]
  - Torque Converter Case [B]

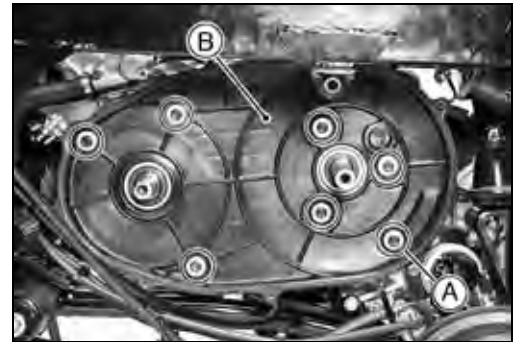
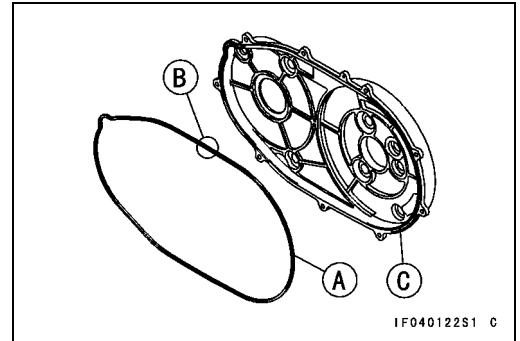

## 6-12 CONVERTER SYSTEM

### Drive Belt

#### Drive Belt Removal

- Remove the torque converter cover (see Torque Converter Removal).
- Pull the parking brake lever up and to the rear to apply the parking brake.

#### **⚠ WARNING**

**Wear gloves to protect your hands from sharp edges during the following steps.**

#### **NOTE**

○ Before removing, observe the direction the belt's printed information [A] (such as numbers or arrow marks) is facing so that it may be reinstalled on the pulleys to rotate in the same direction as originally installed.

- Shift the transmission into any gear.
- Spread the driven pulley sheaves by pushing the inner sheave away from you while turning it clockwise. This will slacken the belt enough so that it may be removed from the driven pulley.
- Lift the belt off the drive pulley.

#### Drive Belt Installation

#### **NOTE**

○ Be sure the printed information faces the same direction so the belt may rotate in the same direction as originally installed. When installing a new belt, install it so the printing can be read from outside the vehicle.

- Installation is basically the reverse of removal.
- Loop the belt over the drive pulley [A] first.
- As above, push the inner sheave [B] of the driven pulley in while turning it clockwise.
- Hold it there and push the belt down into it from the top. This will lock the sheaves open.
- Hold the belt in place in the top of the driven pulley while wrapping it the rest of the way around.
- Put the transmission in neutral, and rotate the driven pulley to allow the belt to return to the top of the sheaves, before measuring belt deflection.

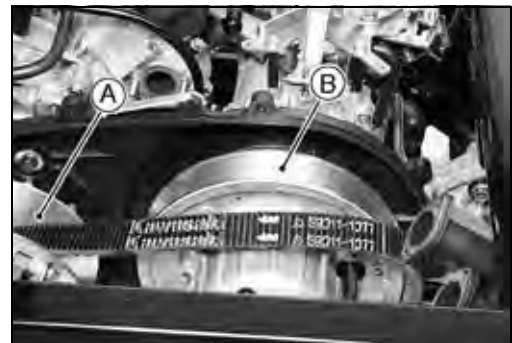

**Drive Belt**

*Drive Belt Deflection Inspection*

- Remove the torque converter cover (see Torque Converter Removal).
- Put the transmission in neutral and rotate the driven pulley by hand to make sure the belt is shifted all the way to the top of the driven pulley.
- Measure the belt deflection as shown:
  - Place a straightedge [A] on top of the belt between the drive pulley [B] and the driven pulley [C].
  - Use a ruler to push the belt away from the straightedge. Push hard, but with no more force than 59 N (6 kg, 13 lb).

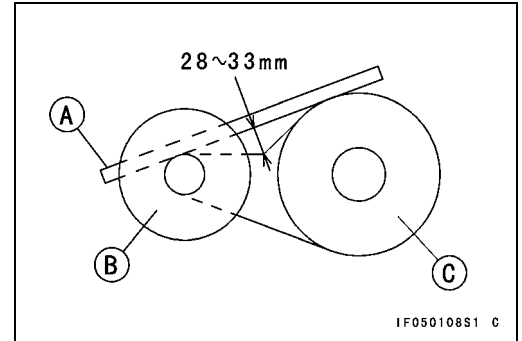

**Belt Deflection**

**Standard: 28 ~ 33 mm (1.1 ~ 1.3 in.)**

- ★ If the belt deflection is not within the specified range, first measure the drive belt width (see Drive Belt Inspection). Adjust the deflection by adding or removing spacers between the driven pulley shaft hub and cam ramp.
- When adjusting the deflection, less is better than more. Less deflection will maintain better performance for more time as the belt width decreases by normal wear, which causes the deflection to increase with usage.

*Drive Belt Deflection Adjustment*

- Disassemble the driven pulley (see Driven Pulley Disassembly).
- ★ If the belt deflection is more than 33 mm (1.30 in.), remove the spacers to decrease it.
  - The rule-of-thumb is: 0.1 mm (0.004 in.) change in spacer thickness equals about 1.3 mm (0.051 in.) change in belt deflection.
- ★ If the belt deflection is less than 28 mm (1.10 in.), add the spacers [A] to increase it.
  - The rule-of-thumb is: 0.1 mm (0.004 in.) change in spacer thickness equals about 1.6 mm (0.063 in.) change in belt deflection.

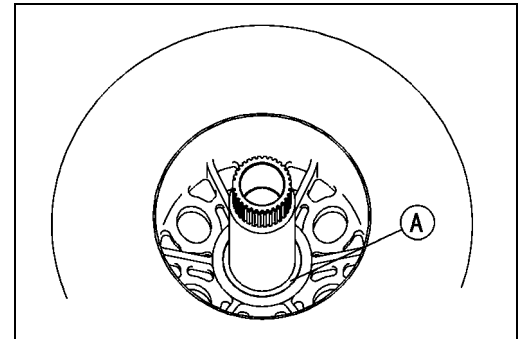

**Spacers**

Part No.	Thickness
92026-1507	0.5 mm (0.020 in.)
92026-1508	0.6 mm (0.024 in.)
92026-1510	0.8 mm (0.031 in.)

- Assemble the driven pulley (see Driven Pulley Assembly).
- With the transmission in neutral, rotate the driven pulley to allow the belt to return to the top of the sheaves before measuring the belt deflection.
- Measure the belt deflection again and repeat the above procedures until it is within the standard range.
- Using a suitable holder, apply a non-permanent locking agent to the driven pulley bolt and tighten it.

**Torque - Driven Pulley Bolt: 93 N·m (9.5 kgf·m, 69 ft·lb)**

*Drive Belt Inspection*

- Refer to Drive Belt Inspection in the Periodic Maintenance chapter.

## 6-14 CONVERTER SYSTEM

### Drive Pulley

#### Drive Pulley Disassembly

- Hold the drive pulley with the drive & driven pulley holder [A] in a vise.

**Special Tool - Drive & Driven Pulley Holder: 57001-1412**

- Mount the pulley holder base plate chamfered side up in a vise, with the short guide (L = 41 mm) (1.614 in.) and short stoppers (L = 16 mm) (0.630 in.) installed.

- Remove:
  - Drive Pulley Cover Bolts [B]
  - Drive Pulley Cover [C]

- Remove:
  - Spring [A]

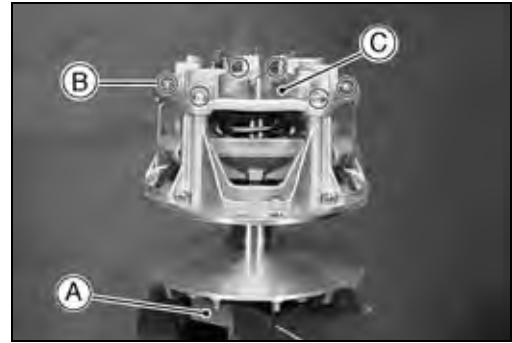

- Put the drive pulley wrench [A] on the spider [B] as shown, and remove the spider with the movable sheave [C] from the fixed sheave [D].

**Special Tool - Drive Pulley Wrench: 57001-1411**

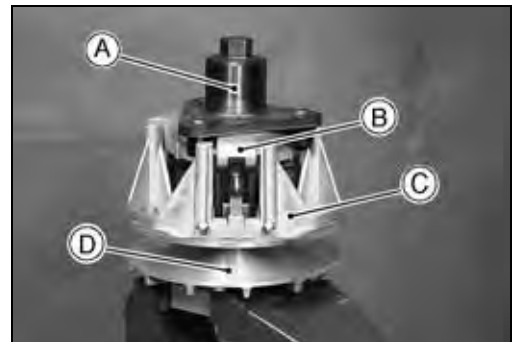

- Remove:
  - Spider [A]
  - Spacer [B]
  - Wear Guides [C]
  - Pins [D] (Use a hand press.)
  - Rollers [E]
  - Nuts [F]
  - Ramp Weight Pin [G]
  - Ramp Weight [H]

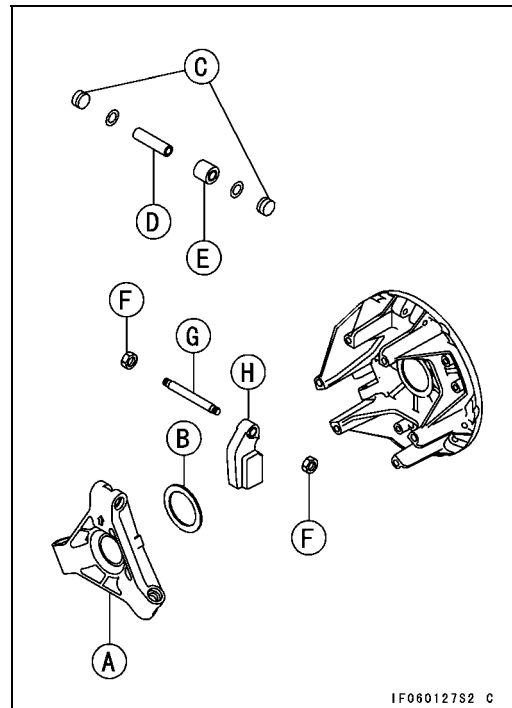

1F060127S2 C

**Drive Pulley**

*Drive Pulley Assembly*

- Install the ramp weight [A] as shown.
- Tighten:
  - Torque - Ramp Weight Nuts [B]: 6.9 N-m (0.70 kgf-m, 61 in-lb)**
- Check the ramp weights swing smoothly.

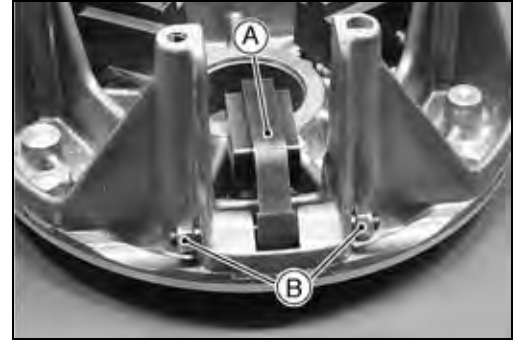

- Install:
  - Roller [A]
  - Spacers [B]
  - Pin [C]
- Press in the pin as shown, so that the pin end is flush [D] with the end of the hole.
- [E] Spider
- [F] Chamfer
- Check the rollers turn freely.

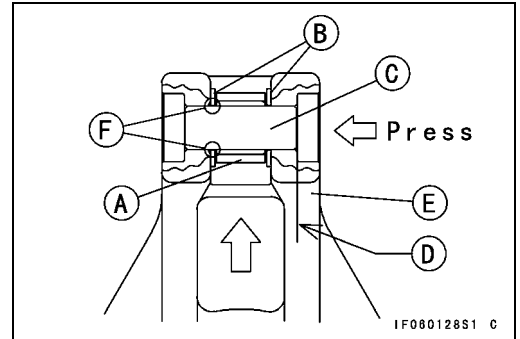

- Hold the fixed sheave [A] with the drive & driven pulley holder [B] in a vise.

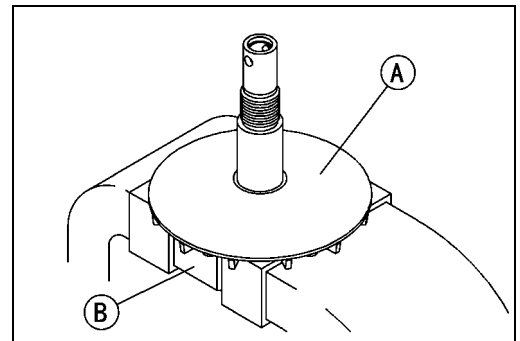

- Clean the threads of the fixed sheave and spider.
- Install:
  - Movable Sheave [A]
  - Spacer [B]
  - Spider [C] and Wear Guides [D]
- Align the arrow [E] on the spider with the boss [F] on the movable sheave.
- Insert the guides so that the rubber side (small diameter) faces inward.

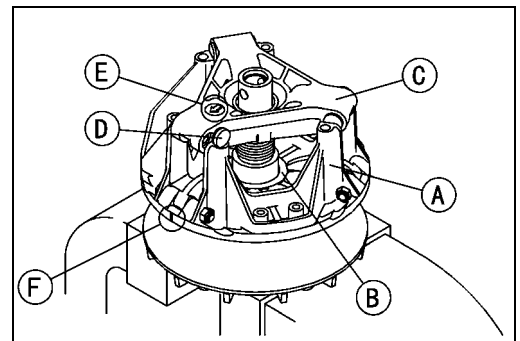

- Fit the spacer [A] in the spider recess [B].

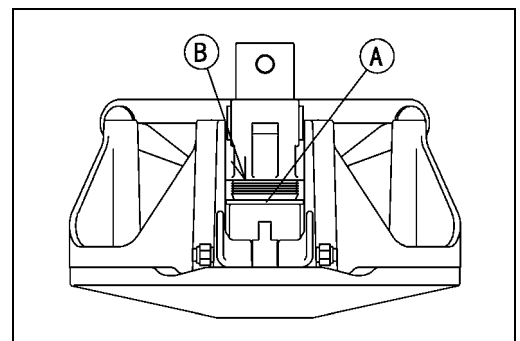

## 6-16 CONVERTER SYSTEM

### Drive Pulley

- Tighten:

Special Tool - Drive Pulley Wrench [A]: 57001-1411

Torque - Spider: 275 N·m (28 kgf·m, 203 ft·lb)

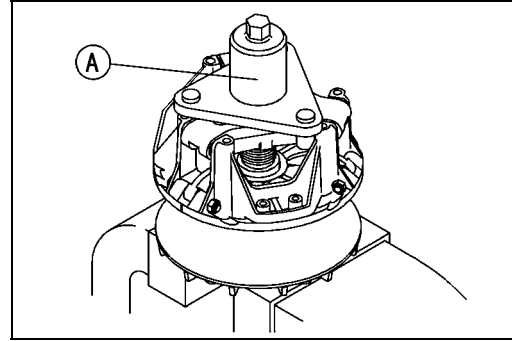

- Put the spring [A] in the groove of the spider.
- Align the arrows [B] on the drive pulley cover and spider.
- Tighten:

Torque - Drive Pulley Cover Bolts: 13 N·m (1.3 kgf·m, 113 in·lb)

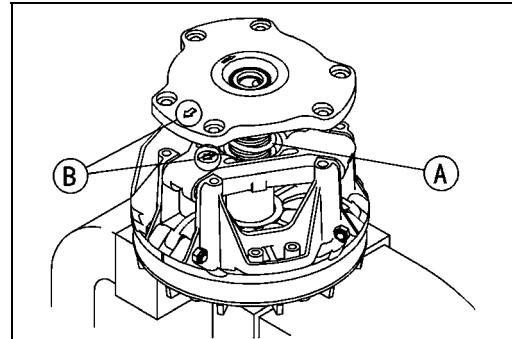

#### Spider/Wear Guide Clearance Adjustment

- Remove the torque converter cover (see Torque Converter Removal).
- Turn the spider counterclockwise and hold it there.
- Measure the resulting clearance between the wear guide [A] and the post [B] on the movable sheave at all three arms.

#### Spider Wear Guide Clearance

Standard: 0 ~ 0.4 mm (0 ~ 0.16 in.)

- ★ If any of the measurements are greater than the maximum, replace all six wear guides (see Drive Pulley Disassembly).
- At the same time, check the following parts for wear.
  - Spider Rollers and Pins
  - Movable Sheave Bushings

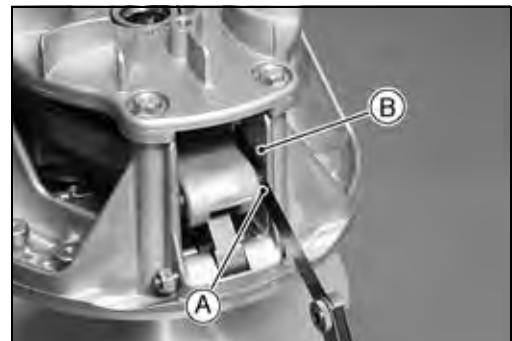

#### Drive Pulley Inspection

- ★ If the sheave surfaces [A] appear damaged, replace the sheaves.

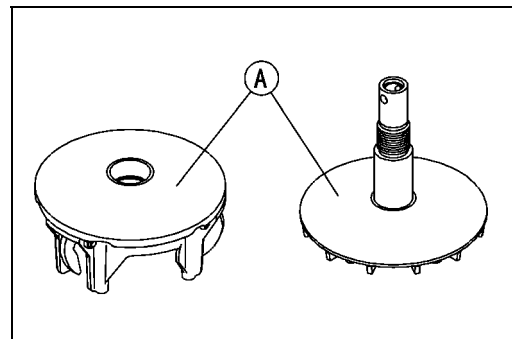

**Drive Pulley**

- Replace any sheave which has uneven wear on the belt contacting surface.  
 [A] Sheave Surface  
 [B] Straight Edge

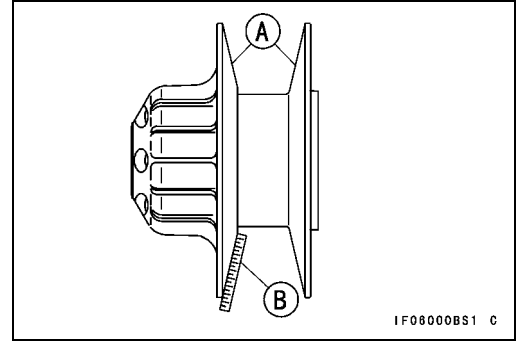

- ★ If the guide bushings are damaged or worn, replace them.

**Cover Bushing Inside Diameter [A]**  
 Standard: 28.075 ~ 28.175 mm (1.105 ~ 1.109 in.)  
 Service Limit: 28.21 mm (1.111 in.)

**Sheave Bushing Inside Diameter [B]**  
 Standard: 38.075 ~ 38.175 mm (1.499 ~ 1.503 in.)  
 Service Limit: 38.21 mm (1.504 in.)

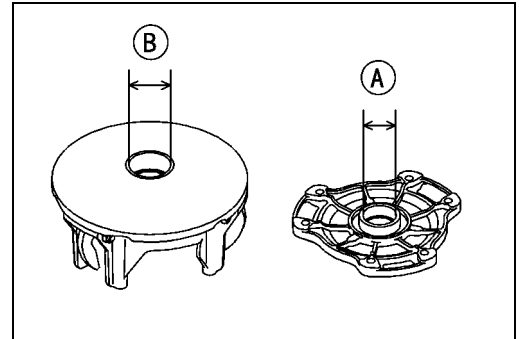

- ★ If the wear guides [A] are damaged or worn, replace them.

**Spider Wear Guide Thickness [B]**  
 Standard: 7.3 ~ 7.7 mm (0.287 ~ 0.303 in.)

- Check the spider wear guide clearance (see Spider Wear Guide Clearance Adjustment).

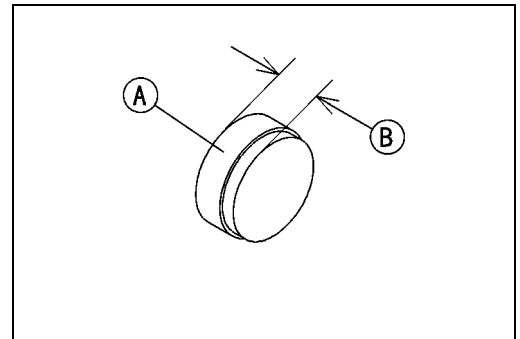

- ★ If the ramp weights [A] are damaged or worn, replace them.
- ★ If the pins [B] are damaged or worn, replace them.

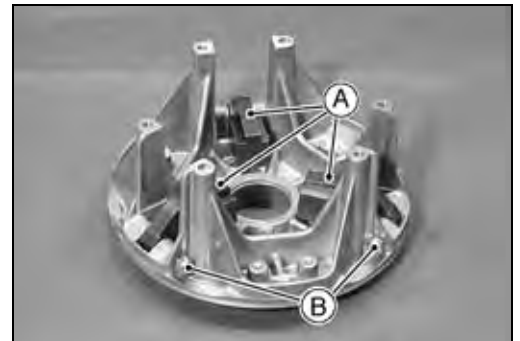

- ★ If the rollers [A] are damaged or worn, replace them,
- ★ If the pins [B] are damaged or worn, replace them.
- ★ If the washers [C] are damaged or worn, replace them.

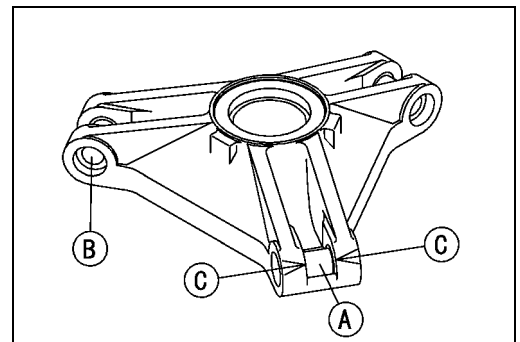

## 6-18 CONVERTER SYSTEM

### Drive Pulley

★ If the spring is damaged, replace the spring.

**Spring Free Length [A]**

Standard: 65.02 mm (2.56 in.)

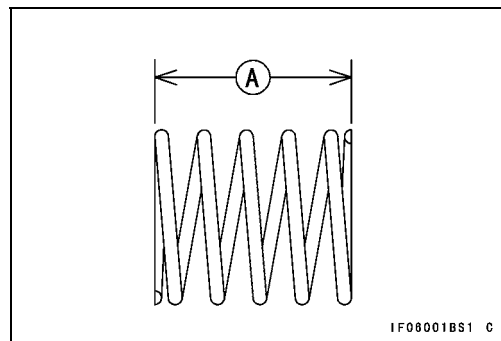

#### *Bushing Installation*

● Press the cover bushing [A] into the cover [B] with a suitable driver until it stops at the shoulder in the hole.

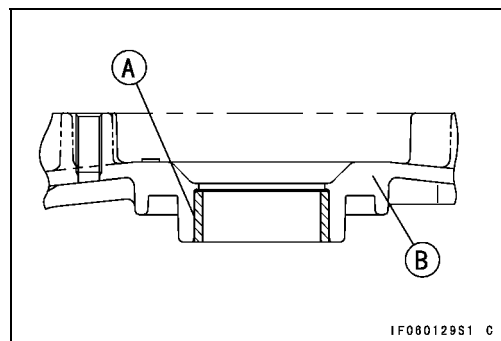

● Press the sheave bushing [A] into the movable sheave [B] with a suitable driver until it stops at the shoulder in the hole.

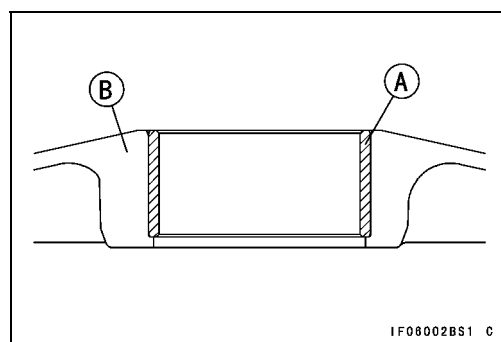



**Driven Pulley**

*Driven Pulley Disassembly*

- Hold the driven pulley [A] with the drive & driven pulley holder and driven pulley holder in a vise.

**Special Tools - Drive & Driven Pulley Holder: 57001-1412**  
**Driven Pulley Holder: 57001-1465**

○Install:

- Base Plate [B]
- Stopper Pins [C]
- Guide Pin [D]
- Stud Bolt [E]
- Adapter [F], bolts [G] and Nuts [H]
- Flange Nut [I]

- Confirm the length [J] is 36 mm (1.4 in.).

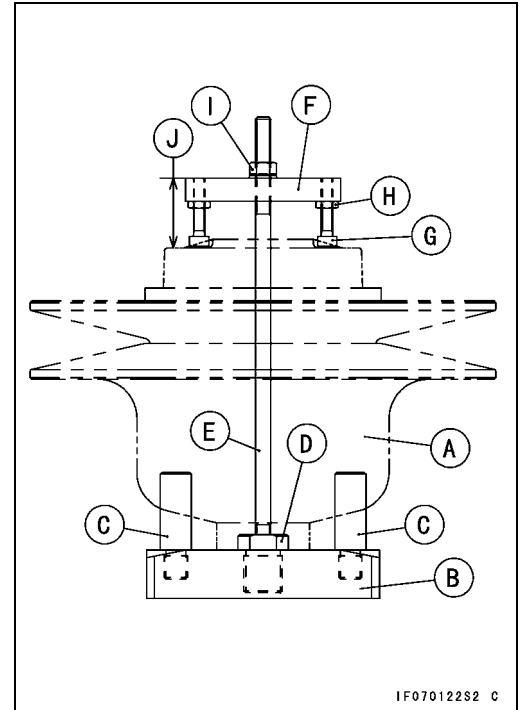

- Turn the flange nut [A] clockwise and remove the circlip [B] with the inside circlip pliers.

**Special Tool - Outside Circlip Pliers: 57001-144**

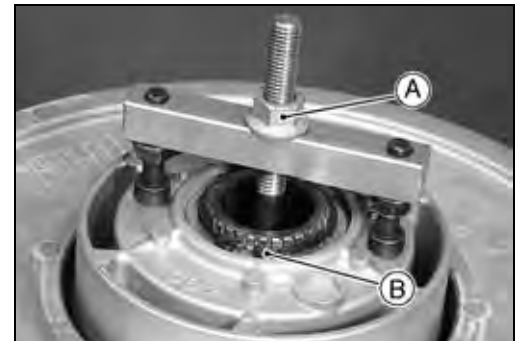

- Turn the flange nut [A] counterclockwise slowly and remove the nut and adapter [B].



## 6-20 CONVERTER SYSTEM

### Driven Pulley

- Remove:
  - Circlip [A]
  - Spacer [B]
  - Ramp [C]
  - Spring [D]
  - Movable Sheave [E]
  - Spacers [F]
  - Fixed Sheave [G]

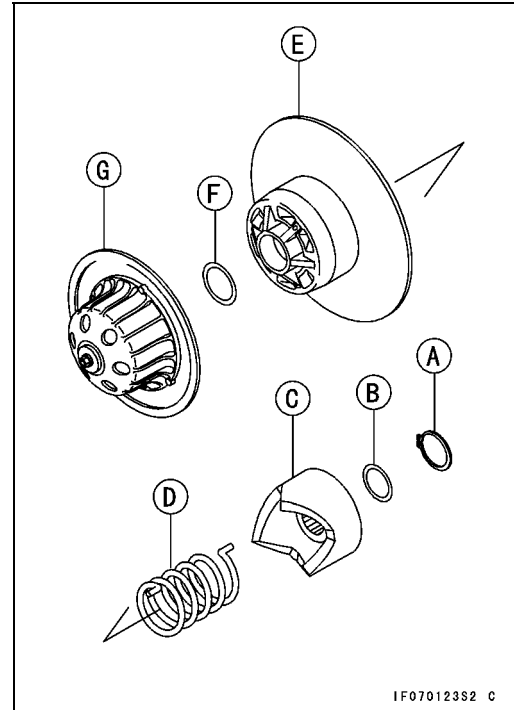

- Remove:
  - Screws [A]
  - Wear Shoes [B]

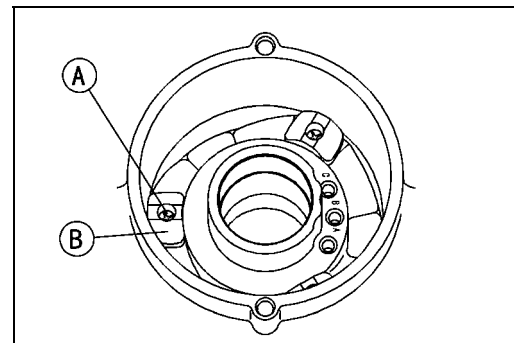

#### *Driven Pulley Assembly*

- Install the wear shoe [A] on the movable sheave [B] as shown.
- Tighten:
  - Torque - Wear Shoe Mounting Screws: 1.1 N·m (0.11 kgf·m, 10 in·lb)**

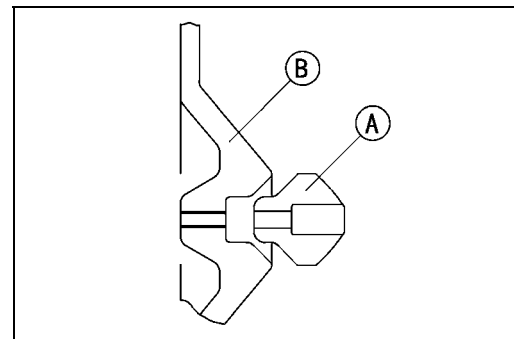

- Hold the fixed sheave with the drive & driven pulley holder and driven pulley holder in a vise.
  - Special Tools - Drive & Driven Pulley Holder: 57001-1412**
  - Driven Pulley Holder: 57001-1465**
- Install the spacers [A] on the fixed sheave [B].

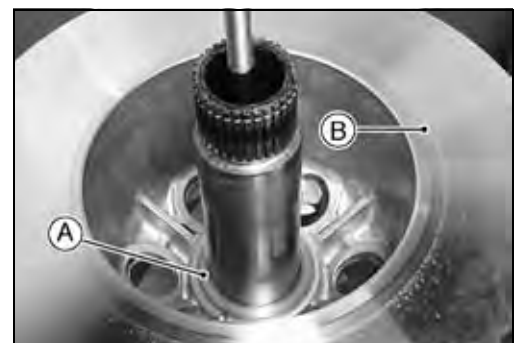

**Driven Pulley**

- Install:
  - Movable Sheave [A]
  - Spring [B]
- Insert the spring end into the hole "C".

**NOTE**

○ The fixed/movable sheave assembly has several different spring locations which affect shifting characteristics of the torque converter.



- Install the ramp [A] on the fixed sheave shaft.
- Insert the spring end [B] into the hole "1".
- Fit the flat portions [C] of the ramp and shaft splines.

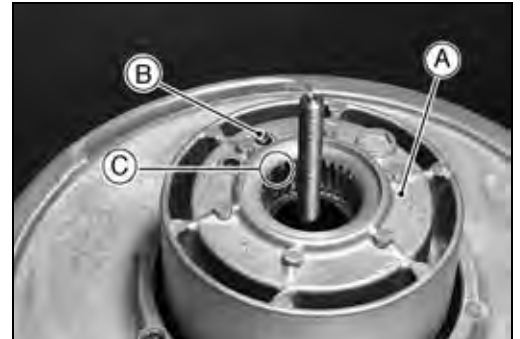

- Put the spacer [A] and circlip [B] on the ramp.
- Install the adapter [C] and tighten the flange nut until the ramp halfway, turn the movable sheave counterclockwise 120° and hold it.
- Push down the ramp until it is bottomed, and install the spacer and circlip.

**Special Tool - Outside Circlip Pliers: 57001-144**

- Put back movable sheave slowly.



*Driven Pulley Inspection*

- ★ If the sheave surfaces [A] appear damaged, replace the sheaves.
- Replace any sheave which has uneven wear on the belt contacting surface.
  - [B] Straight Edge

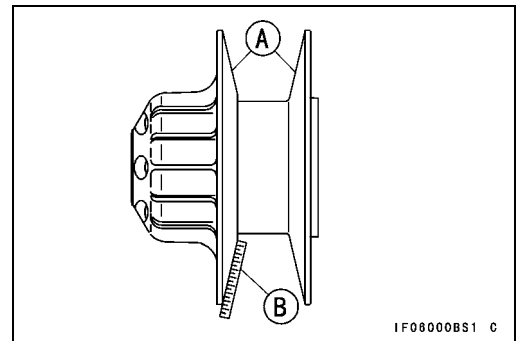

- ★ If the guide bushings [A] are damaged or worn, replace them.

**Sheave Bushing Inside Diameter**

**Standard: 38.075 ~ 38.175 mm (1.499 ~ 1.503 in.)**

**Service Limit: 38.21 mm (1.504 in.)**

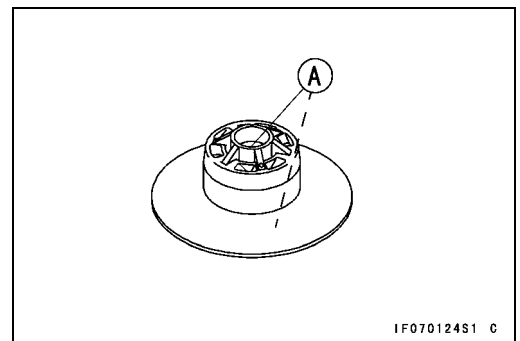

## 6-22 CONVERTER SYSTEM

### Driven Pulley

★ If the splines [A] are damaged or worn, replace them.

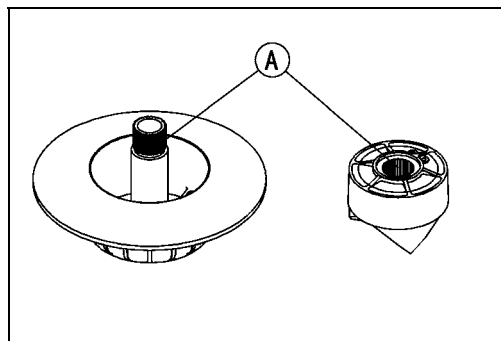

★ If the spring is damaged, replace the spring.

#### Spring Free Length [A]

Standard: 112.6 mm (4.43 in.)

★ If the tabs on the spring are misaligned or the spring coils are distorted, replace the spring.

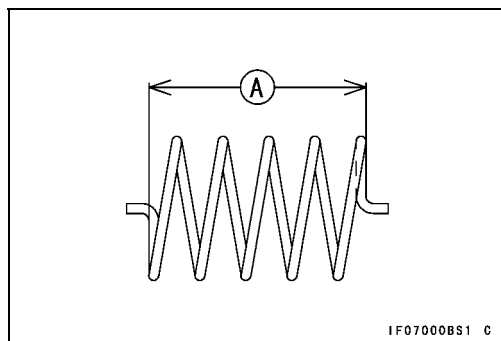

IF07000BS1 C

#### Bushing Installation

● Press the movable sheave bushings [A] into the movable sheave [B] with a suitable driver until the end of the bushing is even with the end [C] of the hole.

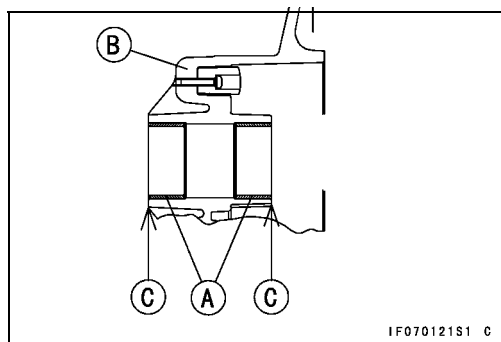

IF070121S1 C

# Engine Lubrication System

## Table of Contents

Exploded View.....	7-2
Specifications .....	7-4
Special Tools and Sealant .....	7-5
Engine Oil Flow Chart.....	7-6
Engine Oil and Oil Filter.....	7-7
Oil Level Inspection.....	7-7
Oil and/or Filter Change.....	7-9
Oil Filter Removal .....	7-9
Oil Filter Installation .....	7-9
Oil Pump and Relief Valve.....	7-10
Oil Pump and Relief Valve Removal .....	7-10
Oil Pump and Relief Valve Installation .....	7-10
Oil Pump and Relief Valve Inspection.....	7-10
Oil Screen.....	7-13
Oil Screen Removal.....	7-13
Oil Screen Installation .....	7-13
Oil Screen Cleaning/Inspection.....	7-13
Oil Pressure Switch .....	7-14
Oil Pressure Switch Removal .....	7-14
Oil Pressure Switch Installation .....	7-14

# 7-2 ENGINE LUBRICATION SYSTEM

## Exploded View

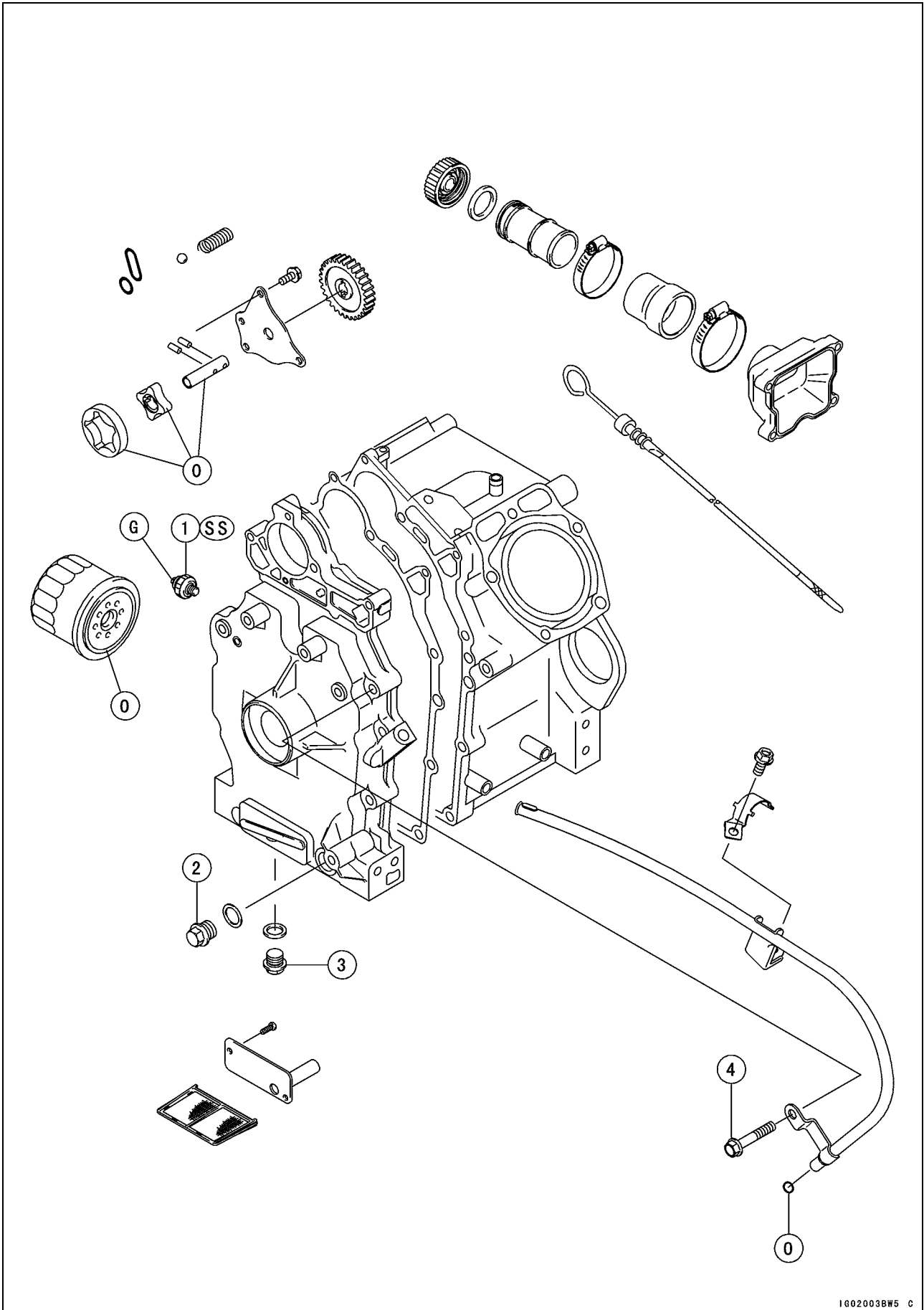

1G02003BW5 C

## ENGINE LUBRICATION SYSTEM 7-3

### Exploded View

No.	Fastener	Torque			Remarks
		N-m	kgf-m	ft-lb	
1	Oil Pressure Switch	9.8	1.0	87 in-lb	SS
2	Engine Oil Drain Plug (M16)	25	2.5	18	
3	Engine Oil Drain Plug (M14)	22	2.2	16	
4	Crankcase Cover Bolt	25	2.5	18	

G: Apply grease to the wire terminal.

O: Apply engine oil.

SS: Apply silicone sealant.

## 7-4 ENGINE LUBRICATION SYSTEM

### Specifications

Item	Standard	Service Limit
<b>Engine Oil and Oil Filter</b>		
Engine oil:		
Grade	API SF or SG API SH or SJ with JASO MA	---
Viscosity	SAE 10W-40	---
Capacity	1.5 L (1.6 US qt) (when filter is not removed) 1.8 L (1.9 US qt) (when filter is removed)	---
Oil level	Between F and L lines on dipstick	---
<b>Oil Pump and Relief Valve</b>		
Inner rotor/outer rotor clearance	Less than 0.14 mm (0.006 in.)	0.3 mm (0.01 in.)
Inner rotor shaft diameter	10.973 ~ 10.984 mm (0.4320 ~ 0.4324 in.)	10.93 mm (0.430 in.)
Outer rotor diameter	40.53 ~ 40.56 mm (1.596 ~ 1.597 in.)	40.47 mm (1.593 in.)
Outer rotor width	9.98 ~ 10.00 mm (0.393 ~ 0.394 in.)	9.83 mm (0.387 in.)
Inner rotor shaft bearing inside diameter	11.000 ~ 11.011 mm (0.4331 ~ 0.4335 in.)	11.07 mm (0.436 in.)
Outer rotor housing inside diameter	40.680 ~ 40.701 mm (1.6016 ~ 1.6024 in.)	40.80 mm (1.606 in.)
Rotor housing depth	10.030 ~ 10.080 mm (0.3949 ~ 0.3968 in.)	10.23 mm (0.403 in.)



**Special Tools and Sealant**

---

**Oil Filter Wrench:**  
**57001-1249**

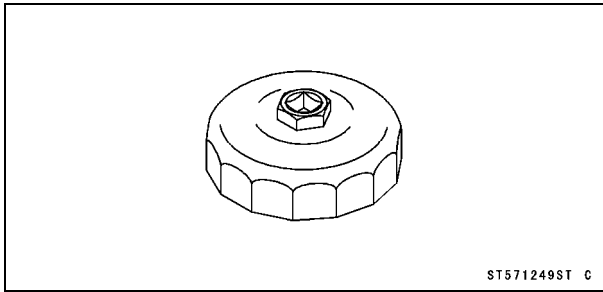

**Kawasaki Bond (Silicone Sealant):**  
**56019-120**

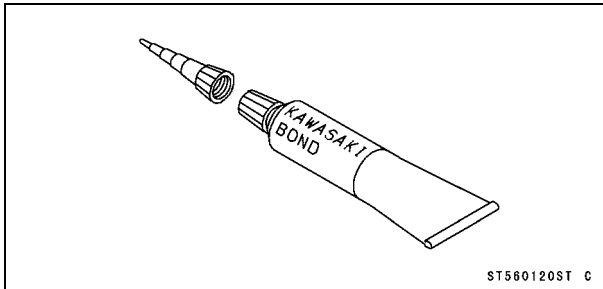

## 7-6 ENGINE LUBRICATION SYSTEM

### Engine Oil Flow Chart

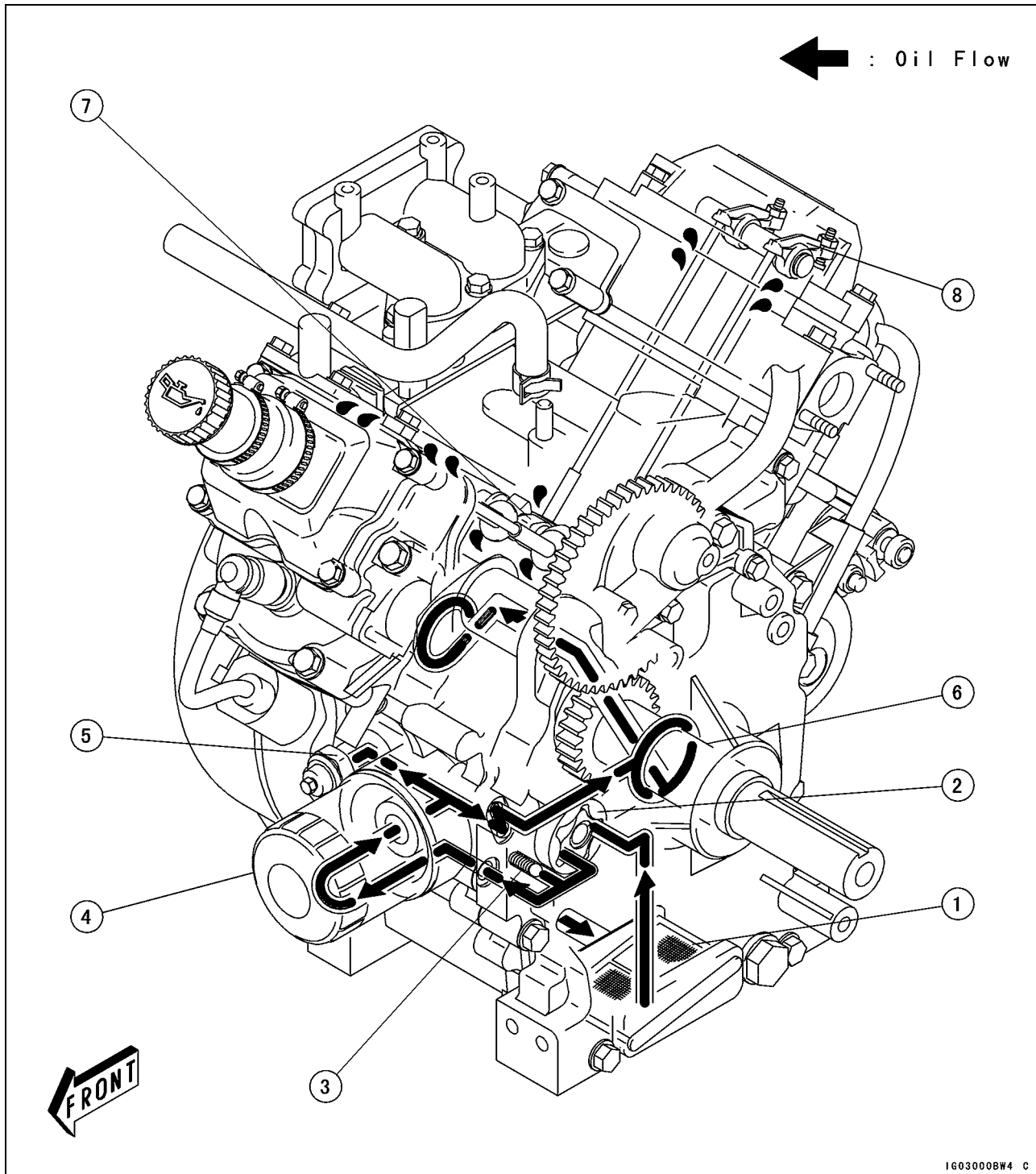

1. Oil Screen
2. Oil Pump
3. Relief Valve
4. Oil Filter
5. Oil Pressure Switch
6. Crankshaft
7. Camshaft
8. Rocker Arm

## Engine Oil and Oil Filter

### **⚠ WARNING**

Vehicle operation with insufficient, deteriorated, or contaminated engine oil will cause accelerated wear and may result in engine seizure, accident, and injury.

### Oil Level Inspection

#### **NOTE**

- If the vehicle has just been used, wait several minutes for all the oil to drain down.
- If the oil has just been changed, start the engine and run it for several minutes at idle speed. This fills the oil filter with oil. Stop the engine, then wait several minutes until the oil settles.

#### **CAUTION**

Racing the engine before the oil reaches every part can cause engine seizure.

- Park the vehicle on level ground.
- Pull out the dipstick [A] out of the dipstick tube, wipe it dry.



#### **NOTE**

- If the vehicle is in 2-person mode, first raise the cargo bed, support with the rod and pull the stored rear seat and place it [A] onto the engine.



#### **NOTE**

- When placing the rear seat on the engine, be sure that the damper [A] is on the carburetor cover [B].

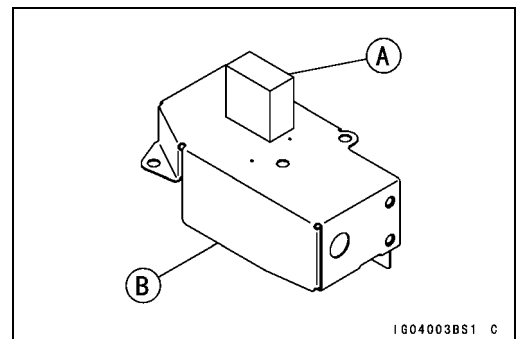

1G04003BS1 C

## 7-8 ENGINE LUBRICATION SYSTEM

### Engine Oil and Oil Filter

- Apply engine oil to the rubber seal lip [A] on the dipstick.

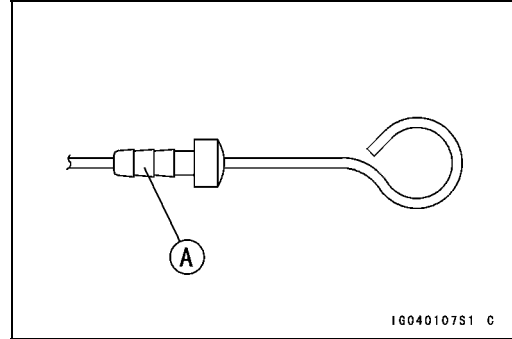

- Face the recess side [A] of the dipstick upward, and insert it.

#### CAUTION

**Do not insert the dipstick except the specified direction. This can damage the plate of the dipstick gauge.**

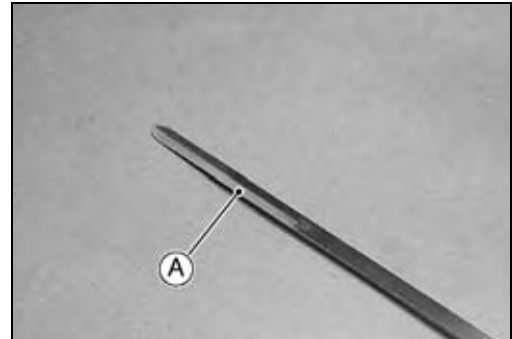

- Align the groove [A] on the dipstick with the mark [B] on the dipstick pipe.

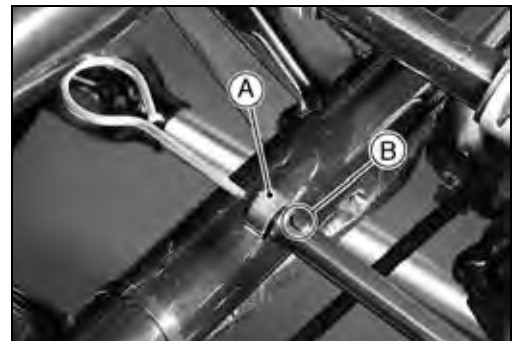

- Pull out the dipstick and check the oil level. The oil level should be between the "F"(Full) and "L"(Low) lines [A] on the dipstick.

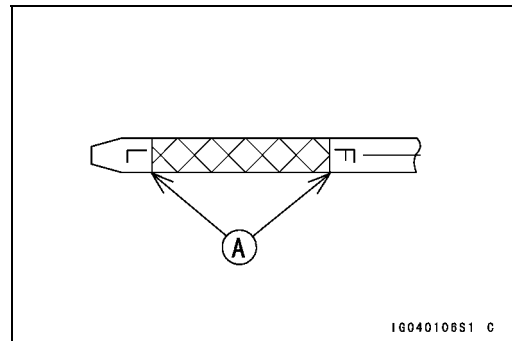

### Engine Oil and Oil Filter

★ If the oil level is too high, remove the excess oil, using a syringe or some other suitable device, or removing the engine oil drain plug, drain the excess oil.

★ If the oil level is too low, add the correct amount of oil through the oil filler opening. Use the same type and make of oil that is already in the engine.

[A] Oil Filler Cap

● When removing or adding the oil through the filler opening, perform the following procedures.

○ In 4-person mode, first fold the rear seat and push its assembly into the stored position, and then raise the cargo bed and support it with the rod.

○ In 2-person mode, raise the cargo bed and support it with the rod.

#### NOTE

○ *If the engine oil type and make are unknown, use any brand of the specified oil to top up the level. Then at your earliest convenience, change the oil completely.*

#### *Oil and/or Filter Change*

● Refer to Oil and/or Filter Change in the Periodic Maintenance chapter.

#### *Oil Filter Removal*

● Refer to Oil Filter Removal in the Periodic Maintenance chapter.

#### *Oil Filter Installation*

● Refer to Oil Filter Installation in the Periodic Maintenance chapter.



## 7-10 ENGINE LUBRICATION SYSTEM

### Oil Pump and Relief Valve

#### *Oil Pump and Relief Valve Removal*

- Remove:
  - Engine
  - Crankcase Cover
  - Oil Pump Cover Bolts [A]
  - Oil Pump Gear [B] and Oil Pump Cover [C]
  - Oil Pump Inner Rotor [D]
  - Oil Pump Outer Rotor [E]
  - Relief Valve Spring [F]
  - Steel Ball [G]

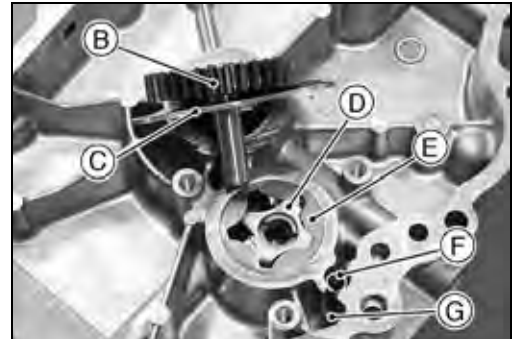
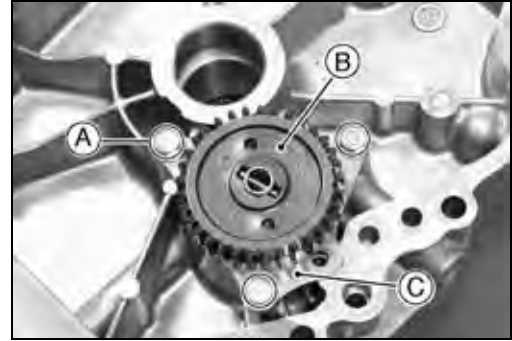

#### *Oil Pump and Relief Valve Installation*

##### **CAUTION**

**Do not allow any dust or other foreign matter to enter the oil pump.**

- Install the pump shaft with its pin [A] in the inner rotor slot [B].
- Install the oil pump cover [C] so that the cover stops the relief valve spring [D].
- Fill the oil pump with engine oil for initial lubrication.

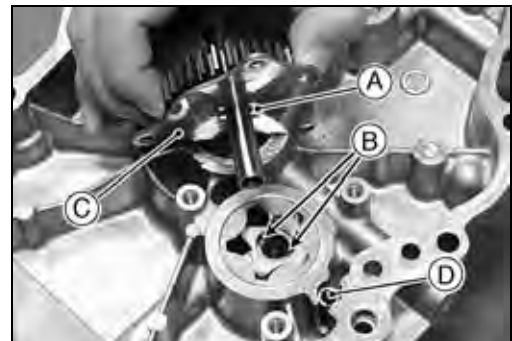

#### *Oil Pump and Relief Valve Inspection*

- Visually inspect the oil pump gear, shaft, inner rotor [A], outer rotor [B], and rotor housing [C] in the crankcase.
- ★ If there is any damage or uneven wear, replace them.

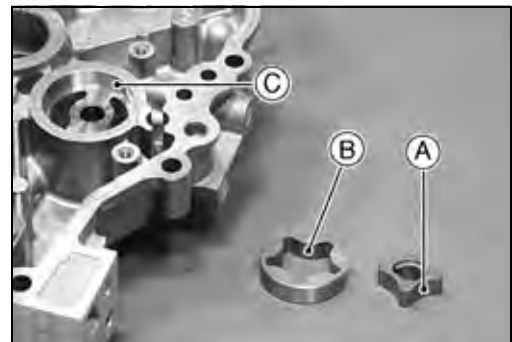

**Oil Pump and Relief Valve**

- Visually inspect the relief valve spring [A], and steel ball [B].
- ★ If any rough spots are found during the above inspection, wash the valve clean with a high flash-point solvent and blow out any foreign particles that may be in the valve with compressed air.



**⚠ WARNING**

**Clean the parts in a well-ventilated area, and take care that there is no spark or flame anywhere near the working area. Because of the danger of highly flammable liquids, do not use gasoline or low flash-point solvents.**

- ★ If cleaning does not solve the problem, replace the relief valve parts.

- Measure the clearance between the high point of the inner rotor and the high point of the outer rotor.
- ★ If the clearance exceeds the service limit, replace the inner and outer rotors as a set.



**Inner Rotor/Outer Rotor Clearance**

**Standard:** Less than 0.14 mm (0.006 in.)  
**Service Limit:** 0.3 mm (0.01 in.)

- Measure the following diameters and width of the oil pump parts.
- ★ If the part(s) has worn past the service limit, replace the worn part(s).

**Inner Rotor Shaft Diameter [A]**

**Standard:** 10.973 ~ 10.984 mm (0.4320 ~ 0.4324 in.)  
**Service Limit:** 10.93 mm (0.430 in.)

**Outer Rotor Diameter [B]**

**Standard:** 40.53 ~ 40.56 mm (1.596 ~ 1.597 in.)  
**Service Limit:** 40.47 mm (1.593 in.)

**Outer Rotor Width [C]**

**Standard:** 9.98 ~ 10.00 mm (0.393 ~ 0.394 in.)  
**Service Limit:** 9.83 mm (0.387 in.)

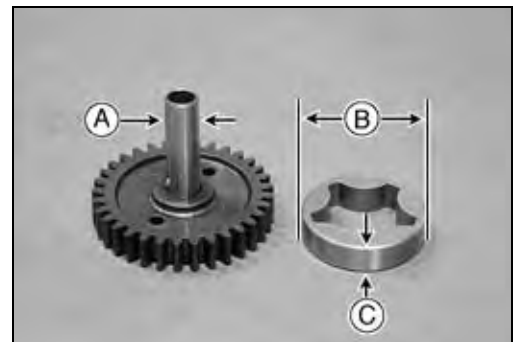

## 7-12 ENGINE LUBRICATION SYSTEM

### Oil Pump and Relief Valve

#### Inner Rotor Shaft Bearing Inside Diameter [A]

Standard: 11.000 ~ 11.011 mm (0.4331 ~ 0.4335 in.)

Service Limit: 11.07 mm (0.436 in.)

#### Outer Rotor Housing Inside Diameter [B]

Standard: 40.680 ~ 40.701 mm (1.6016 ~ 1.6024 in.)

Service Limit: 40.80 mm (1.606 in.)

#### Rotor Housing Depth [C]

Standard: 10.030 ~ 10.080 mm (0.3949 ~ 0.3968 in.)

Service Limit: 10.23 mm (0.403 in.)

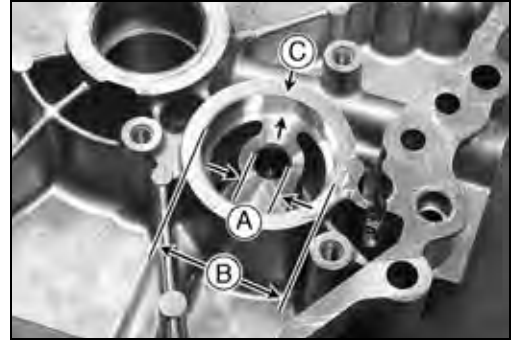



**Oil Screen**

*Oil Screen Removal*

- Remove:
  - Engine
  - Crankcase Cover
  - Oil Screen Cover Screws [A]
  - Oil Screen Cover [B]

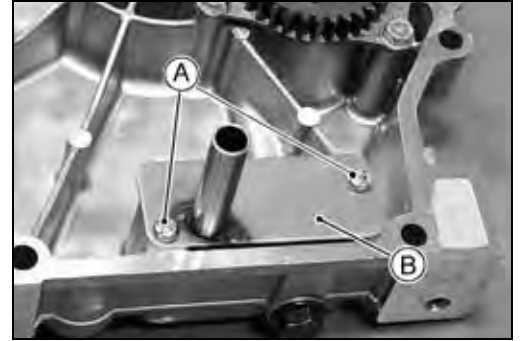

- Remove:
  - Oil Screen [A]



*Oil Screen Installation*

- Clean the oil screen thoroughly whenever it is removed.

*Oil Screen Cleaning/Inspection*

- Clean the oil screen [A] with high flash-point solvent and remove any particles stuck to it.

**⚠ WARNING**

**Clean the screen in a well-ventilated area, and take care that there is no spark or flame anywhere near the working area. Because of the danger of highly flammable liquids, do not use gasoline or low flash-point solvents.**

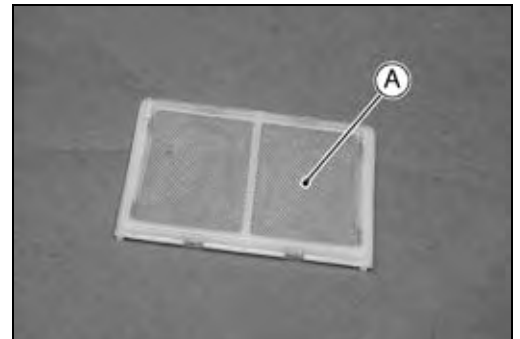

**NOTE**

- *While cleaning the screen, check for any metal particles that might indicate internal engine damage.*
- Check the screen carefully for any damage: holes and broken wire.
- ★ If the screen is damaged, replace it.

## 7-14 ENGINE LUBRICATION SYSTEM

---

### Oil Pressure Switch

---

#### *Oil Pressure Switch Removal*

- Remove:
  - Engine oil (drain, see Engine Oil Change)
  - Switch Wire Terminal [A]
  - Oil Pressure Switch [B]

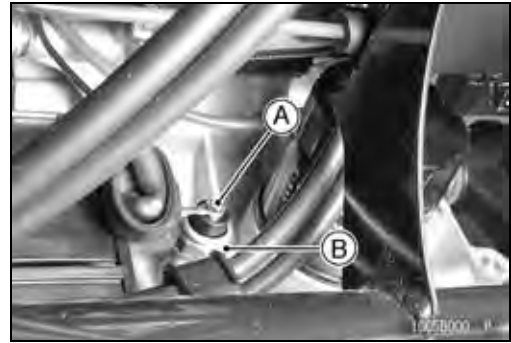

#### *Oil Pressure Switch Installation*

- Apply silicone sealant to the threads of the oil pressure switch and tighten it.
  - Sealant - Kawasaki Bond (Silicone Sealant): 56019-120**
  - Torque - Oil Pressure Switch: 9.8 N·m (1.0 kgf·m, 87 in·lb)**
- Connect the wire to the oil pressure switch.
- Put a light coat of grease on the terminal to prevent corrosion.

# Engine Removal/Installation

## Table of Contents

Exploded View.....	8-2
Engine Removal/Installation.....	8-4
Engine Removal.....	8-4
Engine Installation.....	8-5

## 8-2 ENGINE REMOVAL/INSTALLATION

### Exploded View

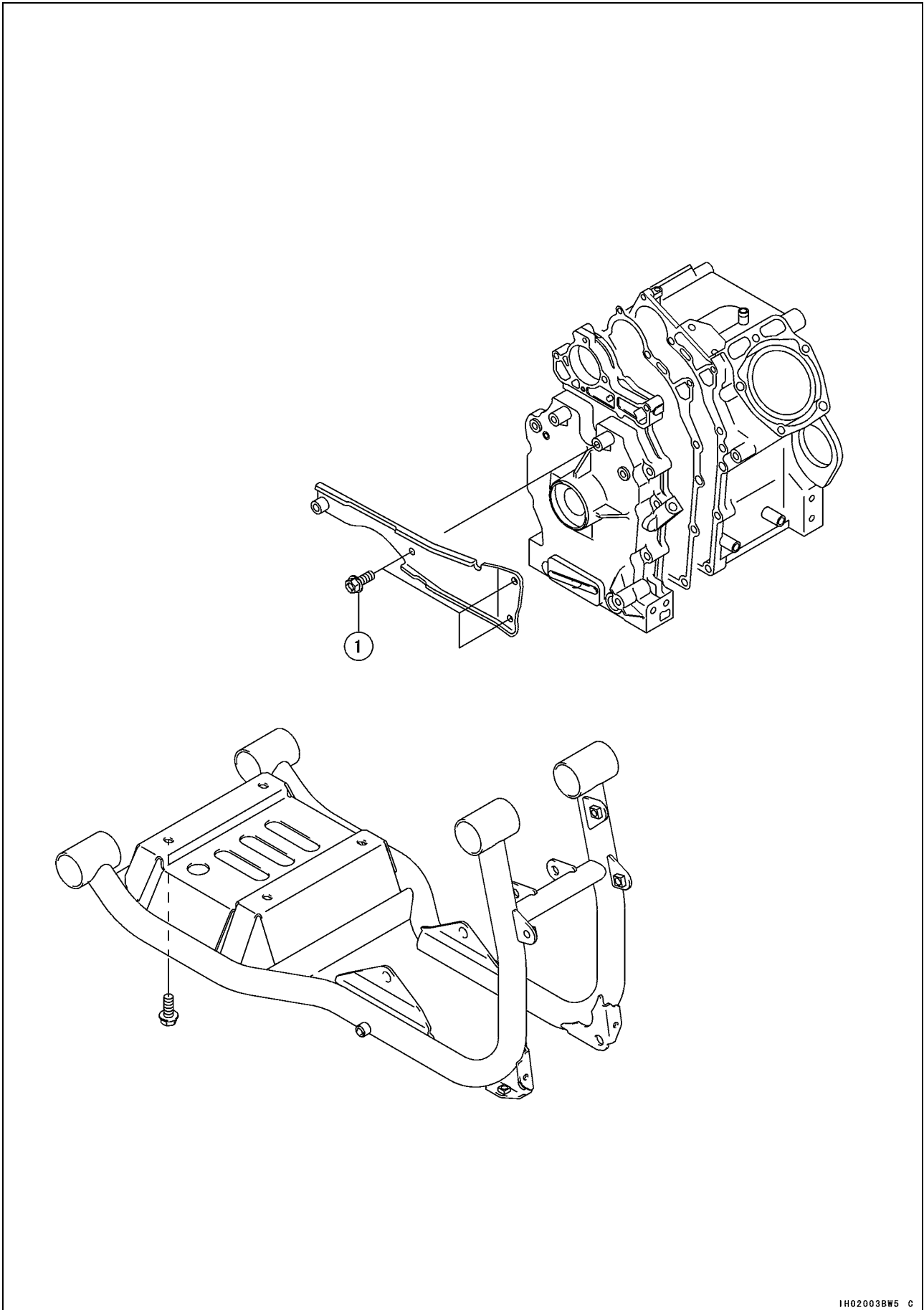

IH02003BW5 C

## ENGINE REMOVAL/INSTALLATION 8-3

### Exploded View

No.	Fastener	Torque			Remarks
		N·m	kgf·m	ft·lb	
1	Engine Positioning Plate Bolts	20	2.0	14	

## 8-4 ENGINE REMOVAL/INSTALLATION

### Engine Removal/Installation

#### Engine Removal

- Disconnect:
  - Battery Terminal Wires (see Electrical System chapter)
- Remove:
  - Engine Oil (drain)
  - Coolant (drain)
  - Cargo Bed (see Frame chapter)
  - Exhaust Pipe (see Engine Top End chapter)
  - Torque Converter and Case (see Torque Converter System chapter)
  - Water Hoses [A]
  - Air Ducts [B]
  - Hoses [C]
  - Throttle Link [D]
  - Engine Positioning Plate [E]
- Remove:
  - Connectors [A]
- Remove:
  - Starter Motor Cable [A] and Wire Connector [B]
  - Engine Ground Wire [C]
- Remove:
  - Engine Mounting Bolts [A]
  - Engine

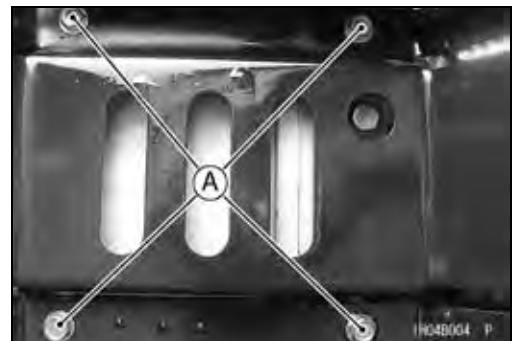
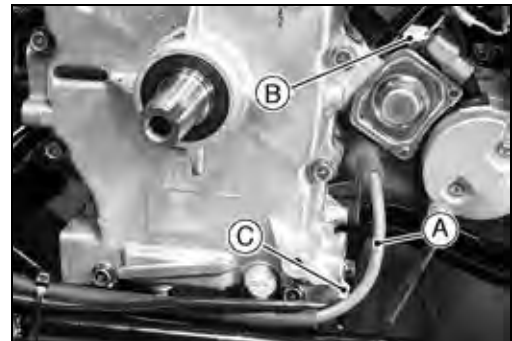
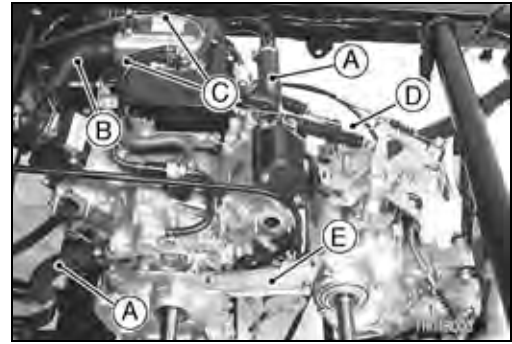

### Engine Removal/Installation

#### *Engine Installation*

- Adjust the engine mounting position for alignment of the torque converter.
- Mount the engine and install the engine mounting bolts loosely.
- Install the engine positioning plate [A] onto the transmission case and crankcase as shown.
- Tighten the bolts [B] [C] until the plate is fitted to the engine completely.

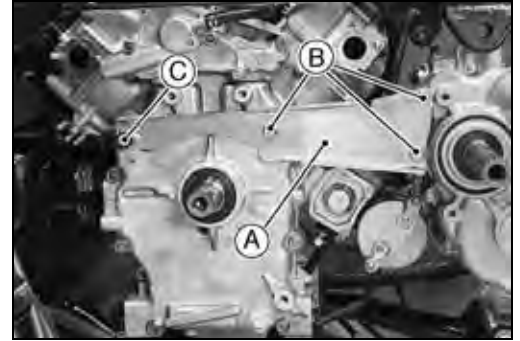

#### **NOTE**

- Use the bolt [C] of the torque converter case temporarily.
- Tighten:
  - Torque - Engine Positioning Plate Bolts: 20 N·m (2.0 kgf·m, 14 ft·lb)**
- Remove the torque converter case bolt [C].
- Adjust:
  - Engine Oil
  - Coolant





# Engine Bottom End

## Table of Contents

Exploded View.....	9-2
Specifications .....	9-4
Special Tools .....	9-6
Crankcase Cover.....	9-7
Crankcase Cover Removal.....	9-7
Crankcase Cover Installation .....	9-7
Camshaft and Tappets.....	9-8
Camshaft Removal .....	9-8
Camshaft Installation .....	9-8
Camshaft Inspection .....	9-8
Cam Wear.....	9-8
Camshaft Bearing/Journal Wear.....	9-9
Cylinders and Pistons.....	9-10
Piston Removal .....	9-10
Piston Installation.....	9-11
Piston Ring, Piston Ring Groove Wear.....	9-13
Piston Ring End Gap .....	9-13
Cylinder Inside Diameter.....	9-13
Piston Diameter .....	9-13
Boring, Honing .....	9-14
Crankshaft and Connecting Rods.....	9-15
Connecting Rod Removal.....	9-15
Connecting Rod Installation .....	9-15
Crankshaft Removal .....	9-15
Crankshaft Installation .....	9-15
Crankshaft Cleaning .....	9-15
Connecting Rod Bend/Twist.....	9-15
Connecting Rod Big End Side Clearance.....	9-16
Connecting Rod Big End Bearing/Crankpin Wear .....	9-16
Crankshaft Runout.....	9-17
Crankshaft Main Bearing/Journal Wear .....	9-18
Breather Valve.....	9-19
Breather Valve Removal .....	9-19
Breather Valve Installation .....	9-19
Breather Valve Inspection .....	9-19

# 9-2 ENGINE BOTTOM END

## Exploded View

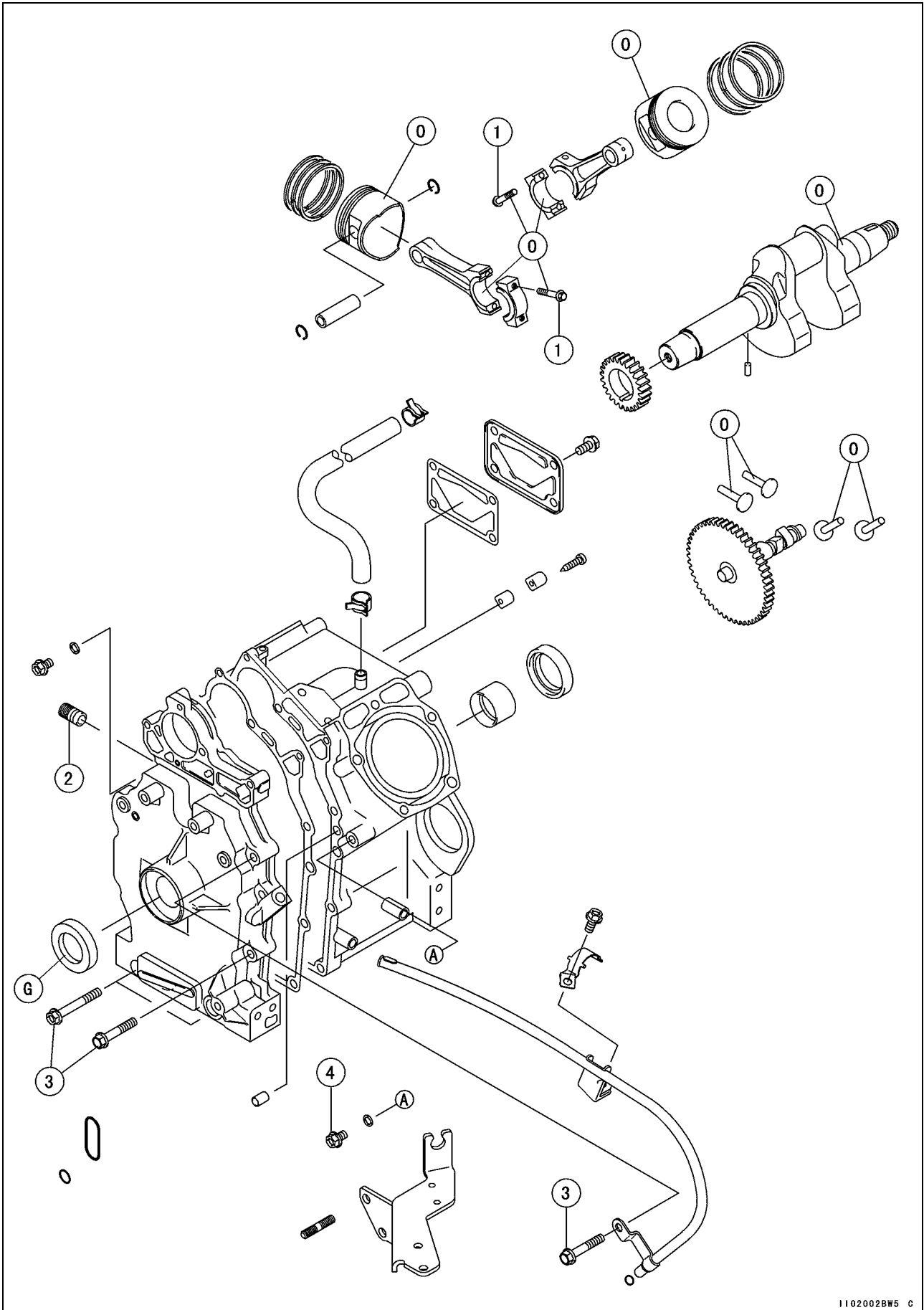

1102002BW5 C

**Exploded View**

No.	Fastener	Torque			Remarks
		N-m	kgf-m	ft-lb	
1	Connecting Rod Big End Cap Bolts	21	2.1	15	
2	Oil Filter Stud Bolt	18	1.8	13	
3	Crankcase Cover Bolts	25	2.5	18	
4	Coolant Drain Plugs (Cylinder)	17	1.7	12	

G: Apply grease.

O: Apply engine oil.

## 9-4 ENGINE BOTTOM END

### Specifications

Item	Standard	Service Limit
<b>Camshaft and Tappets</b>		
Cam height:		
Inlet	25.719 ~ 25.809 mm (1.0126 ~ 1.0161 in.)	25.62 mm (1.009 in.)
Exhaust	25.962 ~ 26.052 mm (1.0221 ~ 1.0257 in.)	25.86 mm (1.018 in.)
Camshaft journal diameter	15.957 ~ 15.975 mm (0.6282 ~ 0.6289 in.)	15.93 mm (0.627 in.)
Camshaft bearing inside diameter	16.000 ~ 16.018 mm (0.6299 ~ 0.6306 in.)	16.08 mm (0.633 in.)
<b>Cylinders and Pistons</b>		
Piston ring/groove clearance:		
Top	0.04 ~ 0.08 mm (0.0016 ~ 0.0031 in.)	0.18 mm (0.0070 in.)
Second	0.03 ~ 0.07 mm (0.0011 ~ 0.0028 in.)	0.17 mm (0.0067 in.)
Piston ring end gap:		
Top, Second	0.2 ~ 0.4 mm (0.008 ~ 0.016 in.)	0.7 mm (0.028 in.)
Cylinder inside diameter	75.980 ~ 76.000 mm (2.9913 ~ 2.9921 in.)	76.10 mm (2.996 in.)
Piston diameter	75.935 ~ 75.950 mm (2.9896 ~ 2.9902 in.)	75.80 mm (2.984 in.)
Oversize piston and rings	+0.50 mm (0.02 in.)	— — —
Piston ring groove width:		
Top	1.23 ~ 1.25 mm (0.0484 ~ 0.0492 in.)	1.33 mm (0.0524 in.)
Second	1.22 ~ 1.24 mm (0.0480 ~ 0.0488 in.)	1.32 mm (0.0520 in.)
Oil	3.01 ~ 3.03 mm (0.1185 ~ 0.1193 in.)	3.11 mm (0.1224 in.)
Piston ring thickness:		
Top, Second	1.17 ~ 1.19 mm (0.0461 ~ 0.0469 in.)	1.1 mm (0.043 in.)
Piston/cylinder clearance	0.030 ~ 0.065 mm (0.0012 ~ 0.0026 in.)	— — —
<b>Crankshaft and Connecting Rods</b>		
Connecting rod bend	0.06/100 mm (0.0024/3.937 in.)	0.2/100 mm (0.008/3.937 in.)
Connecting rod twist	0.06/100 mm (0.0024/3.937 in.)	0.2/100 mm (0.008/3.937 in.)
Connecting rod big end side clearance	0.3 ~ 1.1 mm (0.012 ~ 0.043 in.)	1.3 mm (0.051 in.)
Connecting rod big end bearing/crankpin clearance	0.024 ~ 0.048 mm (0.0009 ~ 0.0019 in.)	0.08 mm (0.0031 in.)
Crankpin diameter	33.967 ~ 33.980 mm (1.3373 ~ 1.3378 in.)	33.95 mm (1.337 in.)

**Specifications**

<b>Item</b>	<b>Standard</b>	<b>Service Limit</b>
Connecting rod big end bearing inside diameter	34.004 ~ 34.015 mm (1.3387 ~ 1.3392 in.)	34.05 mm (1.341 in.)
Crankshaft runout	Less than 0.02 mm (0.0008 in.) TIR	0.05 mm (0.002 in.) TIR
Crankshaft main journal diameter	33.959 ~ 33.975 mm (1.3370 ~ 1.3376 in.)	33.94 mm (1.336 in.)
Crankshaft main bearing inside diameter		
on Crankcase (Bushing)	33.997 ~ 34.064 mm (1.3385 ~ 1.3411 in.)	34.12 mm (1.343 in.)
on Crankcase cover	34.025 ~ 34.041 mm (1.3396 ~ 1.3402 in.)	34.10 mm (1.343 in.)

## 9-6 ENGINE BOTTOM END

### Special Tools

---

**Piston Pin Puller Assembly:**  
**57001-910**

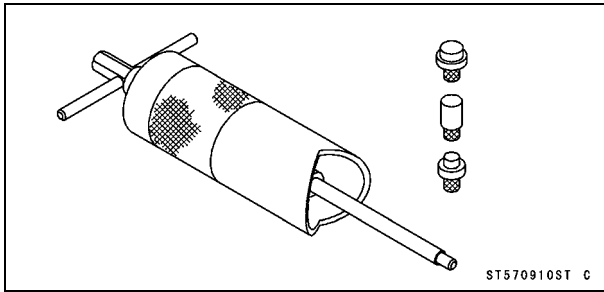

**Piston Ring Compressor Grip:**  
**57001-1095**

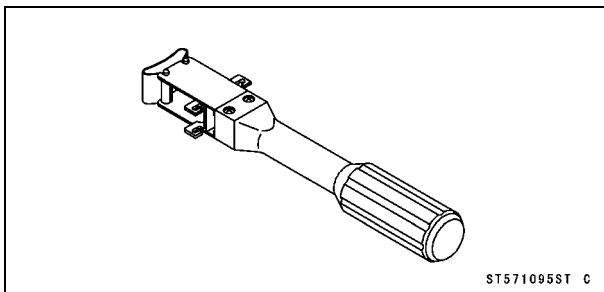

**Piston Ring Compressor Belt,  $\phi 67 \sim \phi 79$ :**  
**57001-1097**

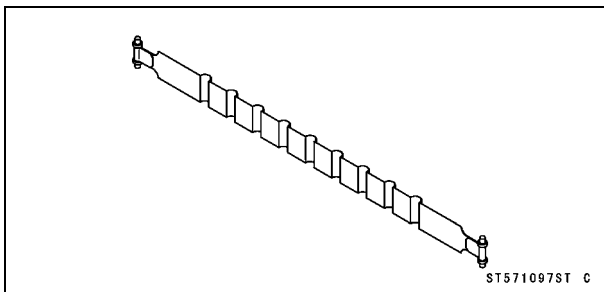

**Crankcase Cover**

*Crankcase Cover Removal*

- Remove:
  - Engine
  - Water Pump
  - Crankcase Cover Bolts [A]
  - Crankcase Cover [B]

**NOTE**

○ If the crankcase cover sticks, tap lightly with a mallet on the alternator side near the knock pins.

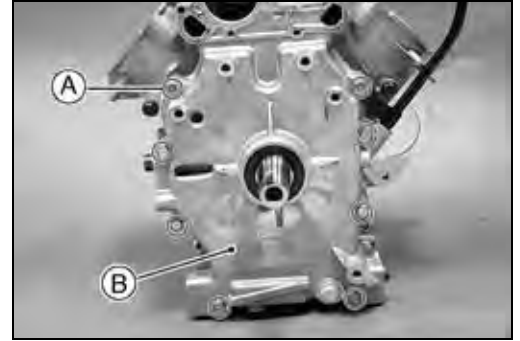

*Crankcase Cover Installation*

- Be sure to replace the oil seal removed with a new one. Press in the new oil seal using a press and suitable tools so that the seal surface is flush with the surface of the crankcase cover.
- Check to see that the crankcase knock pins [A] and O-rings [B] are in place on the crankcase. If any of them has been removed, replace it with a new one.



- Apply engine oil:
  - Crankshaft
  - Camshaft
- Grease:
  - Oil Seal Lips
- Install the crankcase cover so that the oil pump gear [A] is engaged with the crankshaft gear.
- Tighten:
  - Torque - Crankcase Cover Bolts: 25 N·m (2.5 kgf·m, 18 ft·lb)**



- Apply engine oil:
  - Engine Oil Dipstick Tube O-ring [A]
- Check to see the crankshaft turns freely.

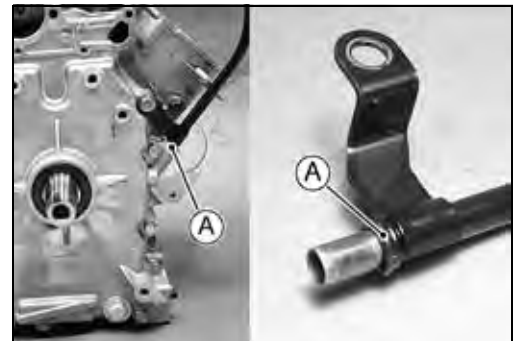

## 9-8 ENGINE BOTTOM END

### Camshaft and Tappets

#### Camshaft Removal

- Remove:
  - Engine
  - Cylinder Heads
  - Crankcase Cover
  - Camshaft [A]
  - Tappets [B]
- Turn the engine upside down to keep the tappets from catching the cam lobes.



#### Camshaft Installation

- Apply engine oil:
  - Tappets
  - Camshaft Journals
  - Cam Surfaces
- Align the timing marks [A] on the camshaft and crankshaft gears.



#### Camshaft Inspection

- Check the camshaft gear [A] for worn or broken teeth.
- ★ If excessively worn or broken teeth are observed, replace the camshaft.



#### Cam Wear

- Measure the cam height [A] of each cam.
- ★ If any cam has worn past the service limit, replace the camshaft.

##### Cam Height (Inlet)

- Standard: 25.719 ~ 25.809 mm (1.0126 ~ 1.0161 in.)
- Service Limit: 25.62 mm (1.009 in.)

##### Cam Height (Exhaust)

- Standard: 25.962 ~ 26.052 mm (1.0221 ~ 1.0257 in.)
- Service Limit: 25.86 mm (1.018 in.)

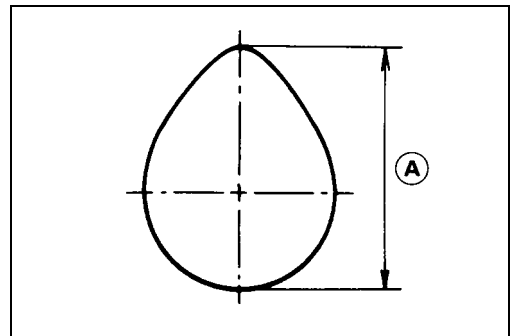



## Camshaft and Tappets

### *Camshaft Bearing/Journal Wear*

- Measure the diameter [A] of the camshaft journals.
- ★ If any journal has worn past the service limit, replace the camshaft with a new one.

#### **Camshaft Journal Diameter**

**Standard:** 15.957 ~ 15.975 mm (0.6282 ~ 0.6289 in.)

**Service Limit:** 15.93 mm (0.627 in.)

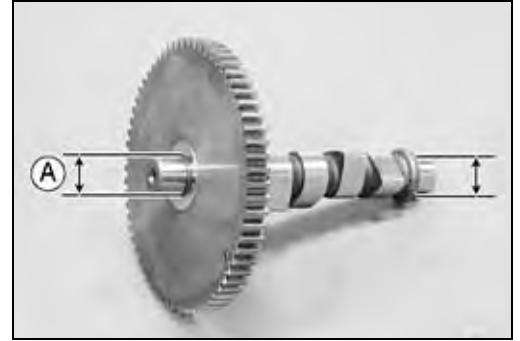

- Measure the inside diameter [A] of the camshaft bearings.
- ★ If any bearing has worn past the service limit, replace the crankcase and/or crankcase cover with a new one.

#### **Camshaft Bearing Inside Diameter**

**Standard:** 16.000 ~ 16.018 mm (0.6299 ~ 0.6306 in.)

**Service Limit:** 16.08 mm (0.633 in.)



## 9-10 ENGINE BOTTOM END

### Cylinders and Pistons

#### Piston Removal

- Remove:
  - Engine
  - Cylinder Heads
  - Crankcase Cover
  - Camshaft
- Turn the crankshaft to expose the two connecting rod big end cap bolts.
- Remove:
  - Connecting Rod Big End Cap Bolts [A]
  - Connecting Rod Big End Caps [B]
- Push the connecting rod ends into the cylinders, and pull the pistons and connecting rods out of the cylinders.

#### CAUTION

Note a location of the arrow on the top of the piston in relation to **MADE IN JAPAN** on the connecting rod. No.1 cylinder piston is opposite of No.2 piston. Keep parts together as a set.

- [A] Arrow
- [B] Alternator
- [C] Large Chamfer
- [D] Raised Letter (MADE IN JAPAN)

- Remove one of the piston pin snap rings [A] with needle nose pliers.

- Remove the piston by pushing the piston pin out the side from which the snap ring was removed. Use the piston pin puller assembly [A] and adapter "C" [B] if the pin is tight.

**Special Tool - Piston Pin Puller Assembly: 5700-910**

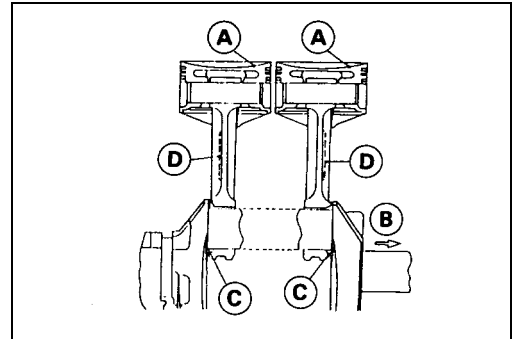
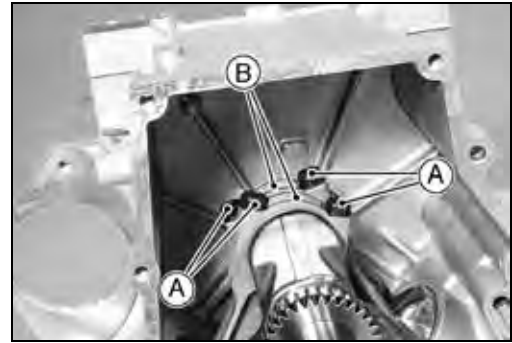

**Cylinders and Pistons**

- Carefully spread the ring opening with your thumbs and then push up on the opposite side of the ring [A] to remove it.
- Remove the 3-piece oil ring with your thumbs in the same manner.

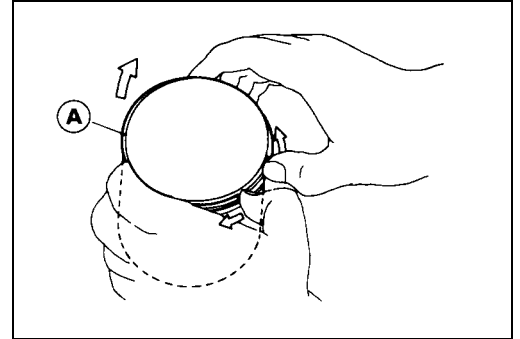

*Piston Installation*

- Apply engine oil:
  - Piston Pin
  - Piston Skirt
  - Cylinder Bore
- Oil Ring Installation:
  - First install the expander in the piston oil ring groove so that the expander ends [A] butt together. Be sure that the expander end rail [B] is inserted into the expander holes.
  - Install the upper and lower steel rails. There is no UP or DOWN to the rails. They can be installed either way.

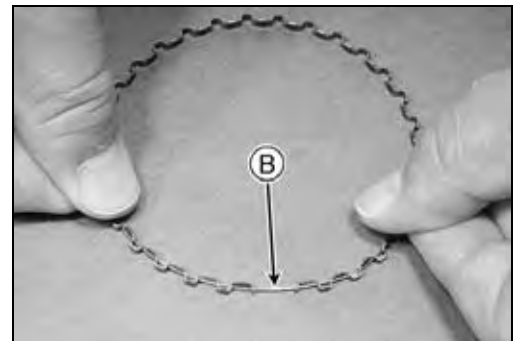
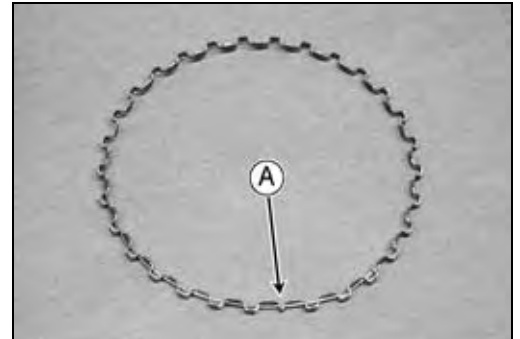

- Do not mix up the top and second rings. The top and second rings are not symmetrical and must be installed with the marked side facing up.
  - Top Ring [A]
  - Second Ring [B]
  - "N" Mark [C]

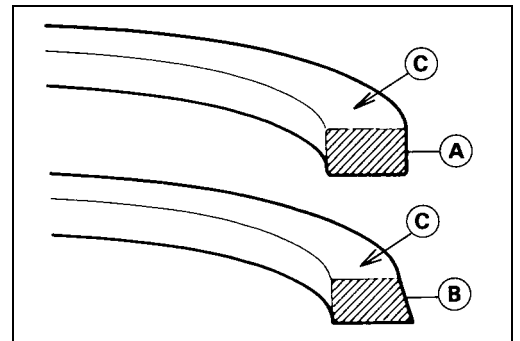

- Position each piston ring end gap as shown.
  - [A] Arrow
  - [B] Top Ring End Gap, Upper Side Rail End Gap
  - [C] 45°
  - [D] Second Ring End Gap, Lower Side Rail End Gap

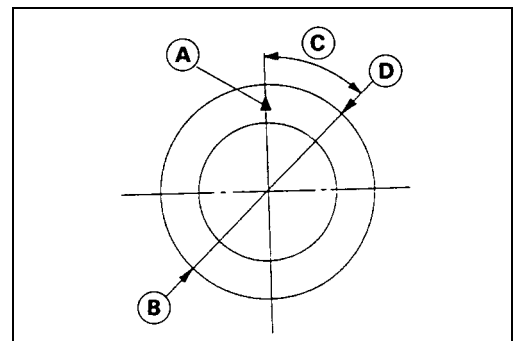

## 9-12 ENGINE BOTTOM END

### Cylinders and Pistons

- Assemble the pistons onto the connecting rods as shown.
- No. 1 cylinder piston, align the arrow on the top of the piston with "MADE IN JAPAN" on the connecting rod.
- No. 2 cylinder piston, align the arrow on the top of the piston with opposite "MADE IN JAPAN" on the connecting rod.

[A] No.1 Cylinder Piston  
[B] No.2 Cylinder Piston  
[C] Arrow  
[D] "MADE IN JAPAN"

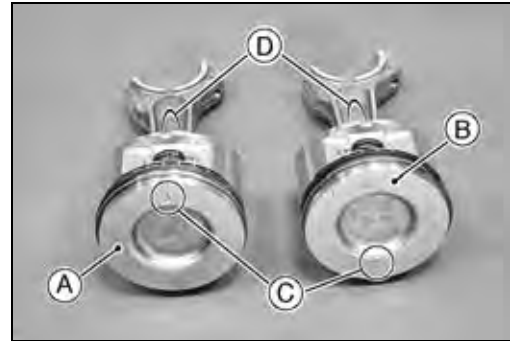

- Fit a new piston pin snap ring into the side of the piston so that the ring opening [A] does not coincide with the notch [B] in the edge of the piston pin hole.

#### CAUTION

**Do not reuse snap rings, as removal weakens and deforms them. They could fall out and score the cylinder wall.**

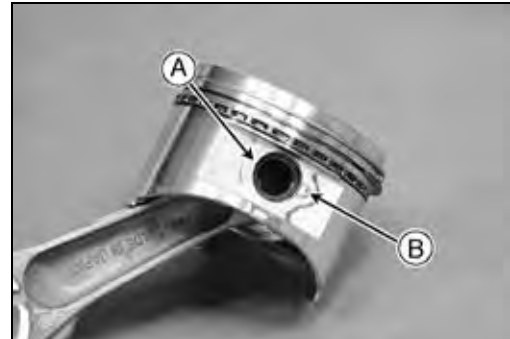

- Using the piston ring compressor grip [A] and the belt [B], insert the piston and connecting rod into the cylinder.

**Special Tools - Piston Ring Compressor Grip: 57001-1095**  
**Piston Ring Compressor Belt,  $\phi 67 \sim \phi 79$ : 57001-1097**

- Insert the piston and connecting rod so that the arrow [C] on the top of the piston points toward the alternator side.
- Lightly tap the top of the piston with a plastic mallet to insert the piston and connecting rod into the cylinder.
- Apply engine oil:
  - Crankpin
  - Threads of Connecting Rod Big End Cap Bolts

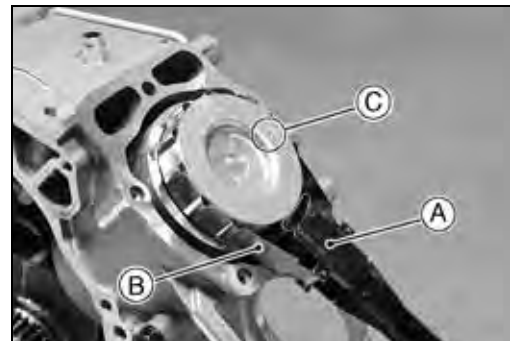

#### CAUTION

**The connecting rod and cap are machined at the factory in the assembled state, so the connecting rod and cap must be replaced as a set.**

- Tighten:
  - Torque - Connecting Rod Big End Cap Bolts: 21 N·m (2.1 kgf·m, 15 ft·lb)

**Cylinders and Pistons**

*Piston Ring, Piston Ring Groove Wear*

- Check for uneven groove wear by inspecting the ring seating.
- ★ The rings should fit perfectly parallel to the groove surfaces. If not, the piston must be replaced.
- With the piston rings in their grooves, make several measurements with a thickness gauge [A] to determine piston ring/groove clearance.



**Piston Ring/Groove Clearance (Top, Second)**

**Standard:**

<b>Top</b>	<b>0.04 ~ 0.08 mm(0.0016 ~ 0.0031 in.)</b>
<b>Second</b>	<b>0.03 ~ 0.07 mm(0.0011 ~ 0.0028 in.)</b>

**Service Limit:**

<b>Top</b>	<b>0.18 mm(0.0070 in.)</b>
<b>Second</b>	<b>0.17 mm(0.0067 in.)</b>

*Piston Ring End Gap*

- Place the piston ring inside the cylinder, using the piston to locate the ring squarely in place. Set it close to the bottom of the cylinder, where cylinder wear is low.
- Measure the gap between the ends of the ring with a thickness gauge.

**Piston Ring End Gap (Top, Second)**

<b>Standard:</b>	<b>0.2 ~ 0.4 mm (0.008 ~ 0.016 in.)</b>
<b>Service Limit:</b>	<b>0.7 mm (0.028 in.)</b>

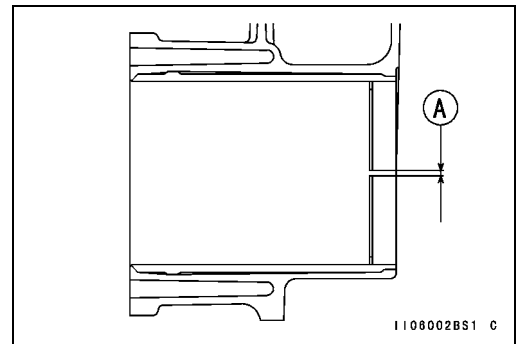

*Cylinder Inside Diameter*

- Take a side-to-side and a front-to-back measurement at each of the 3 locations (total of 6 measurements) shown in the figure.
- ★ If any of the measurements exceeds the service limit, the cylinder will have to be bored to oversize and then honed.

**Cylinder Inside Diameter**

**Standard:** 75.980 ~ 76.000 mm (2.9913 ~ 2.9921 in.) and less than 0.01 mm (0.0004 in.) difference between any two measurements

**Service Limit:** 76.10 mm (2.996 in.) or more than 0.05 mm (0.002 in.) difference between any two measurements

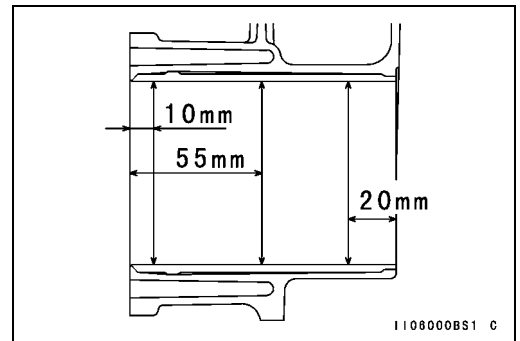

*Piston Diameter*

- Measure the outside diameter [A] of the piston 10 mm (0.4 in.) [B] up from the bottom of the piston at right angles to the direction of the piston pin.
- ★ If the measurement is under the service limit, replace the piston.

**Piston Diameter**

<b>Standard:</b>	<b>75.935 ~ 75.950 mm (2.9896 ~ 2.9902 in.)</b>
<b>Service Limit:</b>	<b>75.80 mm (2.984 in.)</b>

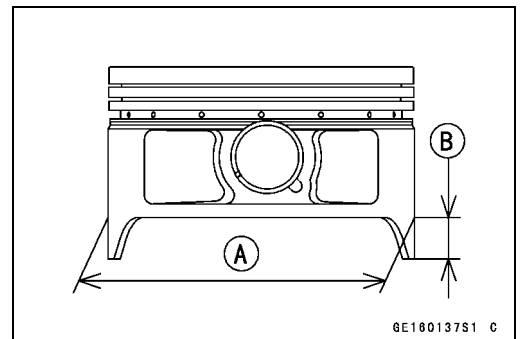

## 9-14 ENGINE BOTTOM END

### Cylinders and Pistons

#### *Boring, Honing*

When boring and honing a cylinder, note the following.

- Oversize piston requires oversize rings.

#### **Oversize Piston and Rings**

**0.50 mm (0.02 in.)      Oversize**

- Before boring a cylinder, first measure the exact diameter of the oversize piston, and then, according to the standard clearance in the Specifications, determine the rebore diameter. However, if the amount of boring necessary would increase the inside diameter by more than 0.50 mm (0.02 in.), the crankcase must be replaced.
- Cylinder inside diameter must not vary more than 0.01 mm (0.0004 in.) at any point.
- Be wary of measurements taken immediately after boring since the heat affects cylinder diameter.
- In the case of rebored cylinder and oversize piston, the service limit for the cylinder is the diameter that the cylinder was bored to plus 0.1 mm (0.004 in.) and the service limit for the piston is the oversize piston original diameter minus 0.15 mm (0.006 in.). If the exact figure for the rebored diameter is unknown, it can be roughly determined by measuring the diameter at the base of the cylinder.

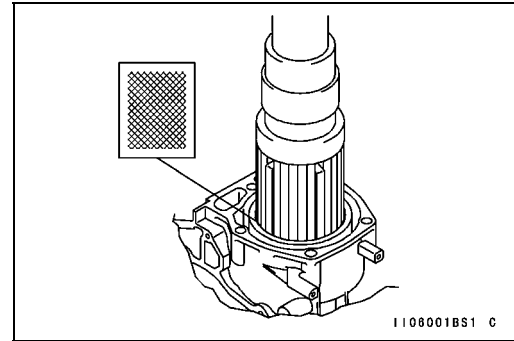

## Crankshaft and Connecting Rods

### Connecting Rod Removal

- Remove the connecting rods during the piston removal.

### Connecting Rod Installation

- Install the connecting rods during the piston installation.

### Crankshaft Removal

- Remove:
  - Engine
  - Cylinder Head
  - Alternator Rotor and Stator
  - Crankcase Cover
  - Camshaft
  - Pistons and Connecting Rods
  - Crankshaft

### Crankshaft Installation

- Grease:
  - Oil Seal Lips
- Apply engine oil:
  - Crankshaft Journal
- Install the crankshaft gear [A] with the chamfered side faces in. The cam timing mark [B] faces out.

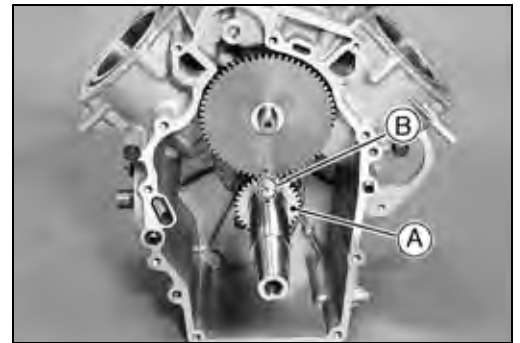

### Crankshaft Cleaning

- After removing, clean the crankshaft with a high flash-point solvent.
- Blow the crankshaft oil passages [A] with compressed air to remove any foreign particles or residue that may have accumulated.

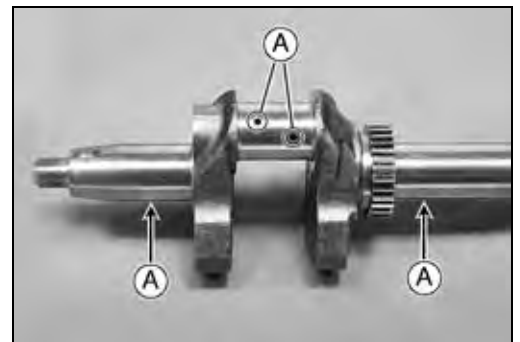

### Connecting Rod Bend/Twist

- Measure the connecting rod bend.
  - Select an arbor [A] of the same diameter as the connecting rod big end, and insert the arbor through the connecting rod big end.
  - Select an arbor [B] of the same diameter as the piston pin and at least 100 mm long, and insert the arbor through the connecting rod small end.
  - On a surface plate, set the big-end arbor on V blocks [C].
  - With the connecting rod held vertically, use a height gauge to measure the difference in the height of the small end arbor above the surface plate over a 100 mm (3.937 in.) length to determine the amount of connecting rod bend.
- ★ If connecting rod bend exceeds the service limit, the connecting rod must be replaced.

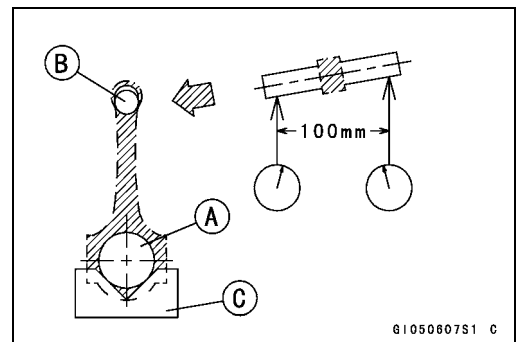

### Connecting Rod Bend

Standard: 0.06/100 mm (0.0024/3.937 in.)

Service Limit: 0.2/100 mm (0.008/3.937 in.)

G105060751 C

## 9-16 ENGINE BOTTOM END

### Crankshaft and Connecting Rods

- Measure the connecting rod twist.
- With the big-end arbor [A] still on the V blocks [C], hold the connecting rod horizontally and measure the amount that the small end arbor [B] varies from being parallel with the surface plate over a 100 mm (3.937 in.) length of the arbor to determine the amount of connecting rod twist.
- ★ If connecting rod twist exceeds the service limit, the connecting rod must be replaced.

#### Connecting Rod Twist

**Standard:** 0.06/100 mm (0.0024/3.937 in.)

**Service Limit:** 0.2/100 mm (0.008/3.937 in.)

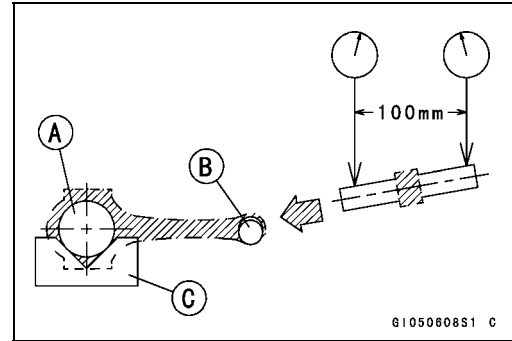

#### Connecting Rod Big End Side Clearance

- Measure connecting rod big end side clearance.
- Insert a thickness gauge [A] between the connecting rod big ends and either crank web to determine clearance.
- ★ If the clearance exceeds the service limit, replace the connecting rods with new ones and then check clearance again. If the clearance is too large after connecting rod replacement, the crankshaft must also be replaced.

#### Connecting Rod Big End Side Clearance

**Standard:** 0.3 ~ 1.1 mm (0.012 ~ 0.043 in.)

**Service Limit:** 1.3 mm (0.051 in.)



#### Connecting Rod Big End Bearing/Crankpin Wear

Bearing/crankpin wear is measured using plastigauge (press gauge), which is inserted into the clearance to be measured. The plastigauge indicates the clearance by the amount it is compressed and widened when the parts are assembled.

- Measure the bearing/crankpin clearance.
- Remove the connecting rod big end cap and wipe the big end bearing and crankpin surface clean of oil.
- Cut a strip of plastigauge to bearing width, and place the strip [A] on the crankpin for the connecting rod parallel to the crankshaft so that the plastigauge will be compressed between the crankpin and the bearing.
- Install the connecting rod big end cap and tighten the big end cap bolts to the specified torque.

**Torque - Connecting Rod Big End Cap Bolts : 21 N·m (2.1 kgf·m, 15 ft·lb)**

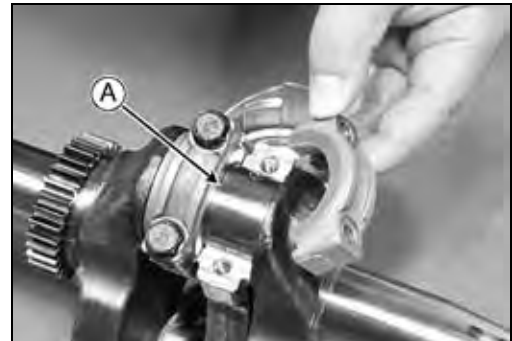

#### NOTE

- Do not turn the crankshaft during clearance measurement.



## Crankshaft and Connecting Rods

- Remove the connecting rod big end cap, and measure the plastigauge width [A] to determine the bearing/crankpin clearance.

### Connecting Rod Big End Bearing/Crankpin Clearance

**Standard:** 0.024 ~ 0.048 mm (0.0009 ~ 0.0019 in.)

**Service Limit:** 0.08 mm (0.0031 in.)

### NOTE

- The clearance less than 0.025 mm (0.00098 in.) can not be measured by plastigauge.
- ★ If the clearance is within the standard, no connecting rod replacement is required.
- ★ If the clearance is between the standard (maximum) and the service limit, replace the connecting rod and cap as a set.
- ★ If the clearance exceeds the service limit, measure the diameter [A] of the crankpin.
- ★ If the crankpin has worn past the service limit, replace the crankshaft with a new one.

### Crankpin Diameter

**Standard:** 33.967 ~ 33.980 mm (1.3373 ~ 1.3378 in.)

**Service Limit:** 33.95 mm (1.337 in.)

The connecting rod big end inside diameter can be measured as following.

- Install the connecting rod big end cap and tighten the big end cap bolts to the specified torque.

**Torque - Connecting Rod Big End Cap Bolts : 21 N·m (2.1 kgf·m, 15 ft·lb)**

- Measure the inside diameter [A] of the connecting rod big end.
- ★ If the connecting rod big end bore has worn past the service limit, replace the connecting rod and cap as a set.

### Connecting Rod Big End Inside Diameter

**Standard:** 34.004 ~ 34.015 mm (1.3387 ~ 1.3392 in.)

**Service Limit:** 34.05 mm (1.341 in.)

### Crankshaft Runout

- Measure the crankshaft runout.
- Set the crankshaft in a flywheel alignment jig or on V blocks.
- Set a dial against both bearing journals.
- Turn the crankshaft slowly to measure the runout. The difference between the highest and lowest dial gauge readings (TIR) is the amount of runout.
- ★ If the measurement exceeds the service limit, replace the crankshaft.

### Crankshaft Runout

**Standard:** Less than 0.02 mm (0.0008 in.) TIR

**Service Limit:** 0.05 mm (0.002 in.) TIR

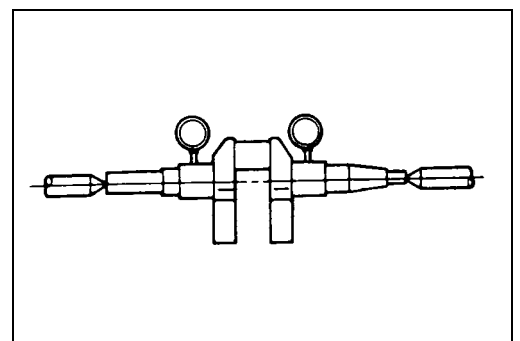
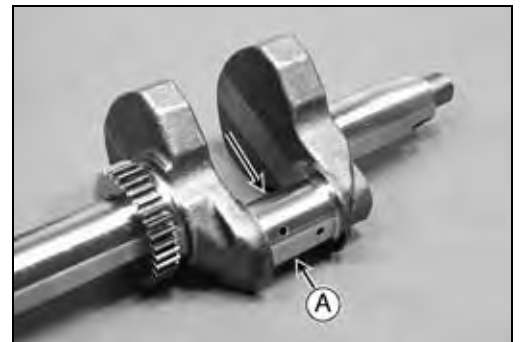
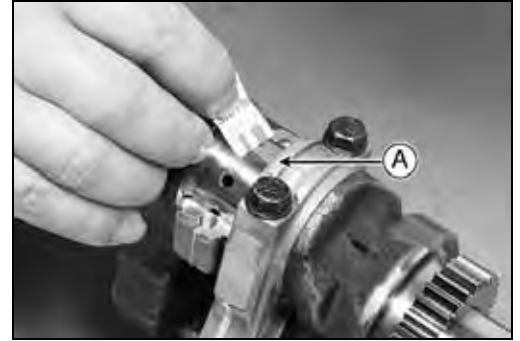

## 9-18 ENGINE BOTTOM END

### Crankshaft and Connecting Rods

#### *Crankshaft Main Bearing/Journal Wear*

- Measure the diameter [A] of the crankshaft main journal.
- ★ If the journal has worn past the service limit, replace the crankshaft with a new one.

#### **Crankshaft Main Journal Diameter**

**Standard:** 33.959 ~ 33.975 mm (1.3370 ~ 1.3376 in.)

**Service Limit:** 33.94 mm (1.336 in.)

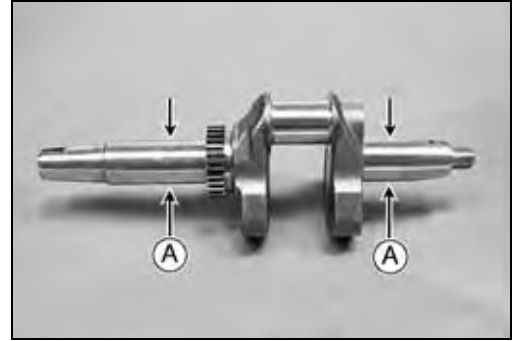

- Measure the inside diameter [A] of the crankshaft main bearing.
- ★ If the bearing has worn past the service limit, replace the crankcase bushing and/or crankcase cover with a new one.

#### **Crankshaft Main Bearing Inside Diameter**

##### **Standard:**

**Bushing** 33.997 ~ 34.064 mm (1.3385 ~ 1.3411 in.)

**Cover** 34.025 ~ 34.041 mm (1.3396 ~ 1.3402 in.)

##### **Service Limit:**

**Bushing** 34.12 mm(1.343 in.)

**Cover** 34.10 mm(1.343 in.)

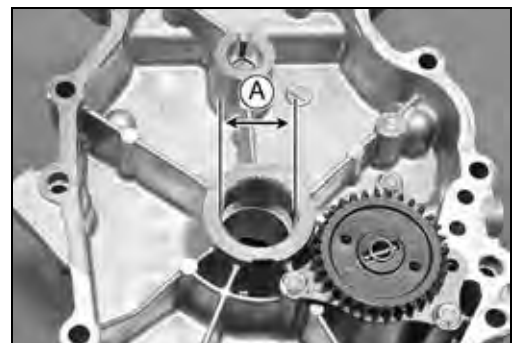

## Breather Valve

### Breather Valve Removal

- Remove:
  - Alternator and Stator
  - Breather Cover Bolts [A]
  - Breather Cover [B]

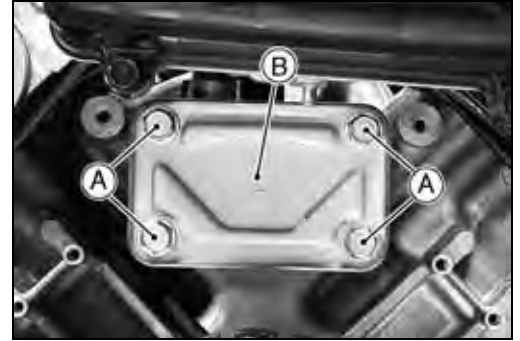

- Remove:
  - Breather Valve [A]



### Breather Valve Installation

- Place the reed valve on the seat so that there is a slight gap between the valve and the seat.
  - Mounting Screw [A]
  - Back Plate [B]
  - Reed Valve [C]
  - Gap [D]

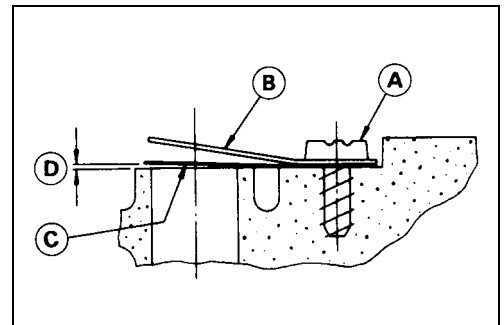

- Be sure the drain back hole [A] does not accumulate with slugs before installing the breather valve.
- Align center of the valve seat with center of the reed valve and back plate, then tighten the mounting screw.

#### NOTE

- *The mounting screw is a self-tapping one. Be aware that misthreading or overtightening screw will strip the female threads and ruin the hole.*



### Breather Valve Inspection

- Inspect the reed valve for breakage, hair cracks or distortion, replace it if necessary.
- Inspect the back plate for damage or rough contact surface, replace it if necessary.
- Inspect the valve seating surface. The surface should be free of nicks or burrs.



# Transmission

## Table of Contents

Exploded View.....	10-2	2WD/4WD Shift Cable	
Specifications .....	10-8	Lubrication.....	10-24
Special Tools and Sealant .....	10-9	2WD/4WD Shift Cable Inspection	10-24
Transmission Oil.....	10-10	2WD/4WD Shift Mechanism	
Transmission Oil Level Inspection	10-10	Removal .....	10-24
Transmission Oil Change.....	10-10	2WD/4WD Shift Mechanism	
Transmission Case.....	10-11	Installation.....	10-25
Transmission Case Removal .....	10-11	2WD/4WD Shift Mechanism	
Transmission Case Installation ...	10-11	Inspection.....	10-25
Transmission Case Splitting .....	10-12	Differential Gears and Shift	
Transmission Case Assembly.....	10-12	Mechanism .....	10-26
Transmission and Shift Mechanism ..	10-13	Differential Shift Cable	
Transmission and Hi/Low Shift		Adjustment.....	10-26
Cables Installation.....	10-13	Differential Shift Cable	
Shift Lever Position Inspection.....	10-16	Lubrication.....	10-26
Shift Lever Position Adjustment...	10-16	Differential Shift Cable Inspection	10-26
Transmission Shift Cable		Differential Shift Mechanism	
Inspection.....	10-17	Removal.....	10-26
Transmission Removal .....	10-17	Differential Shift Mechanism	
Transmission Installation .....	10-18	Installation.....	10-27
Transmission and Shift		Differential Shift Mechanism	
Mechanism Inspection .....	10-19	Inspection.....	10-27
Hi/Low Gears and Shift Mechanism ..	10-20	Differential Gear Removal.....	10-27
Hi/Low Shift Cable Installation .....	10-20	Differential Gear Installation.....	10-28
Hi/Low Shift Cable Inspection.....	10-20	Differential Gear Inspection .....	10-28
Hi/Low Gear and Shift Mechanism		Bearings and Oil Seal.....	10-29
Removal .....	10-20	Bearing Replacement .....	10-29
Hi/Low Gear and Shift Mechanism		Ball Bearing Inspection .....	10-29
Installation .....	10-21	Needle Bearing Inspection.....	10-29
Hi/Low Gear and Shift Mechanism		Oil Seal Inspection .....	10-29
Inspection .....	10-22	Transmission Sectional Figure .....	10-30
2WD/4WD Shift Mechanism.....	10-23		
2WD/4WD Shift Cable			
Adjustment .....	10-23		

# 10-2 TRANSMISSION

## Exploded View

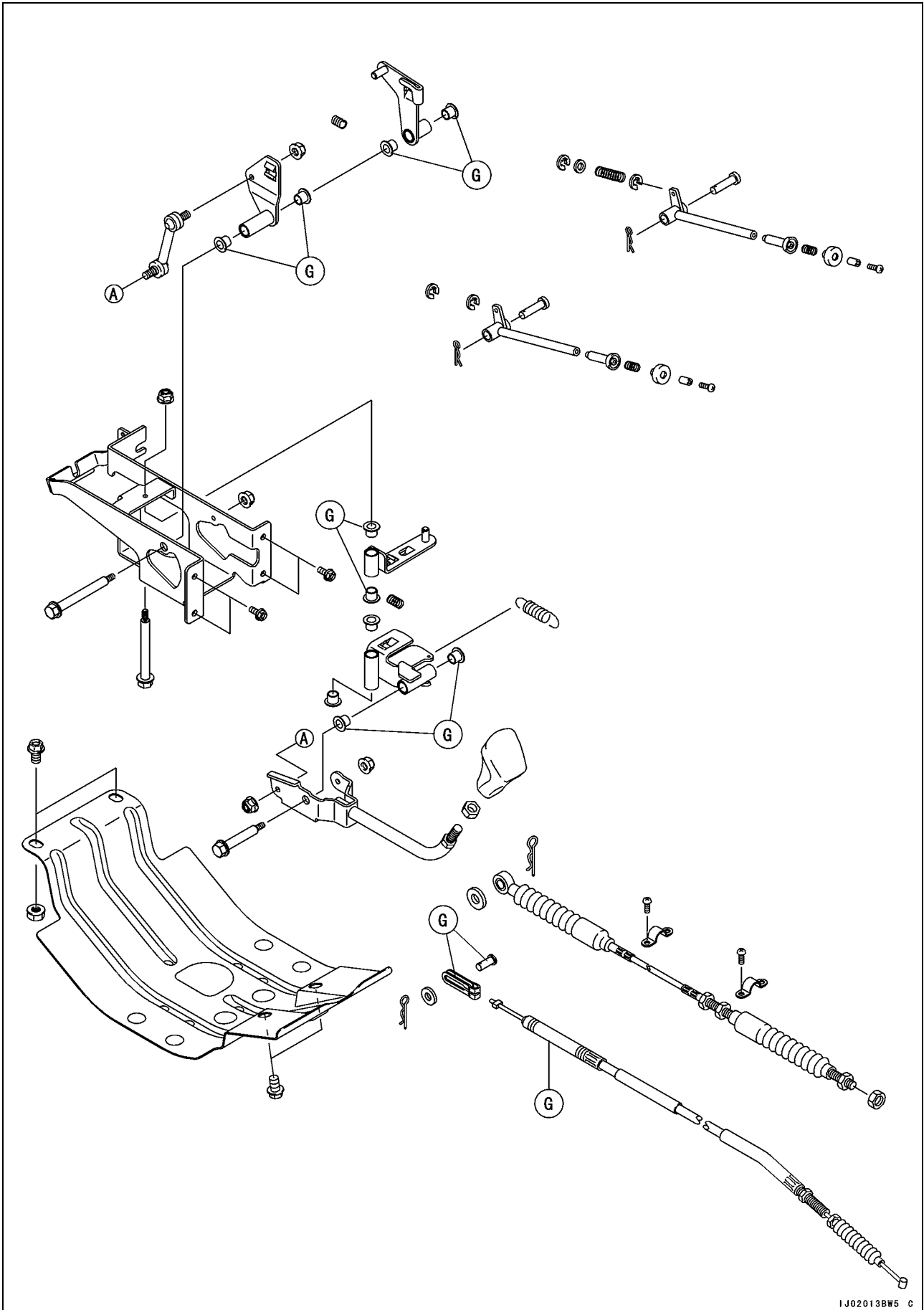

---

**Exploded View**

---

G: Apply grease.

# 10-4 TRANSMISSION

## Exploded View

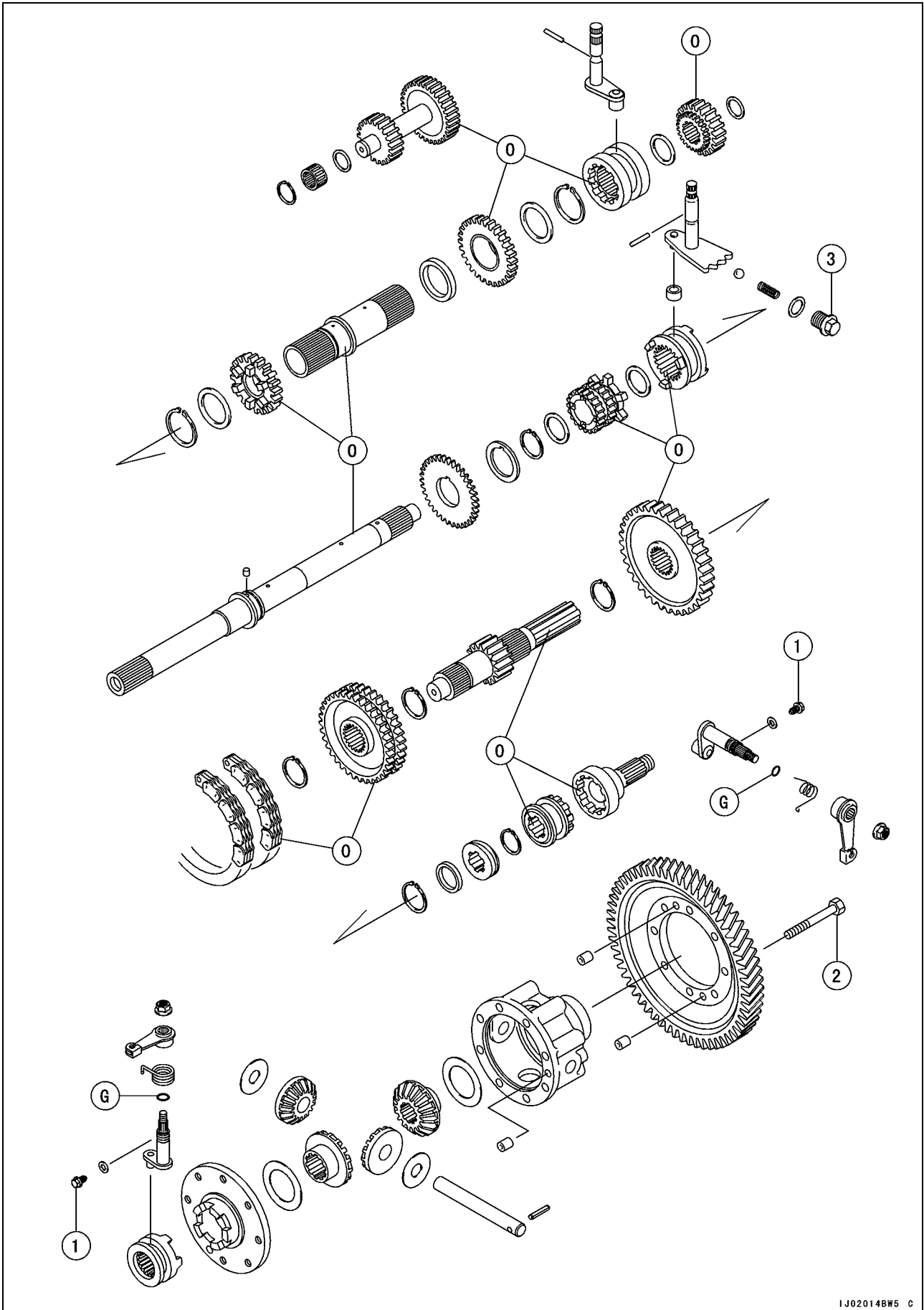

IJ02014BW5 C



**Exploded View**

No.	Fastener	Torque			Remarks
		N-m	kgf-m	ft-lb	
1	Shift Shaft Stop Bolts	7.8	0.80	69 in-lb	
2	Differential Gear Housing Bolts	57	5.8	42	
3	Shift Arm Positioning Bolt	37	3.8	27	

G: Apply grease.

L: Apply a non-permanent locking agent.

O: Apply engine oil.

# 10-6 TRANSMISSION

## Exploded View

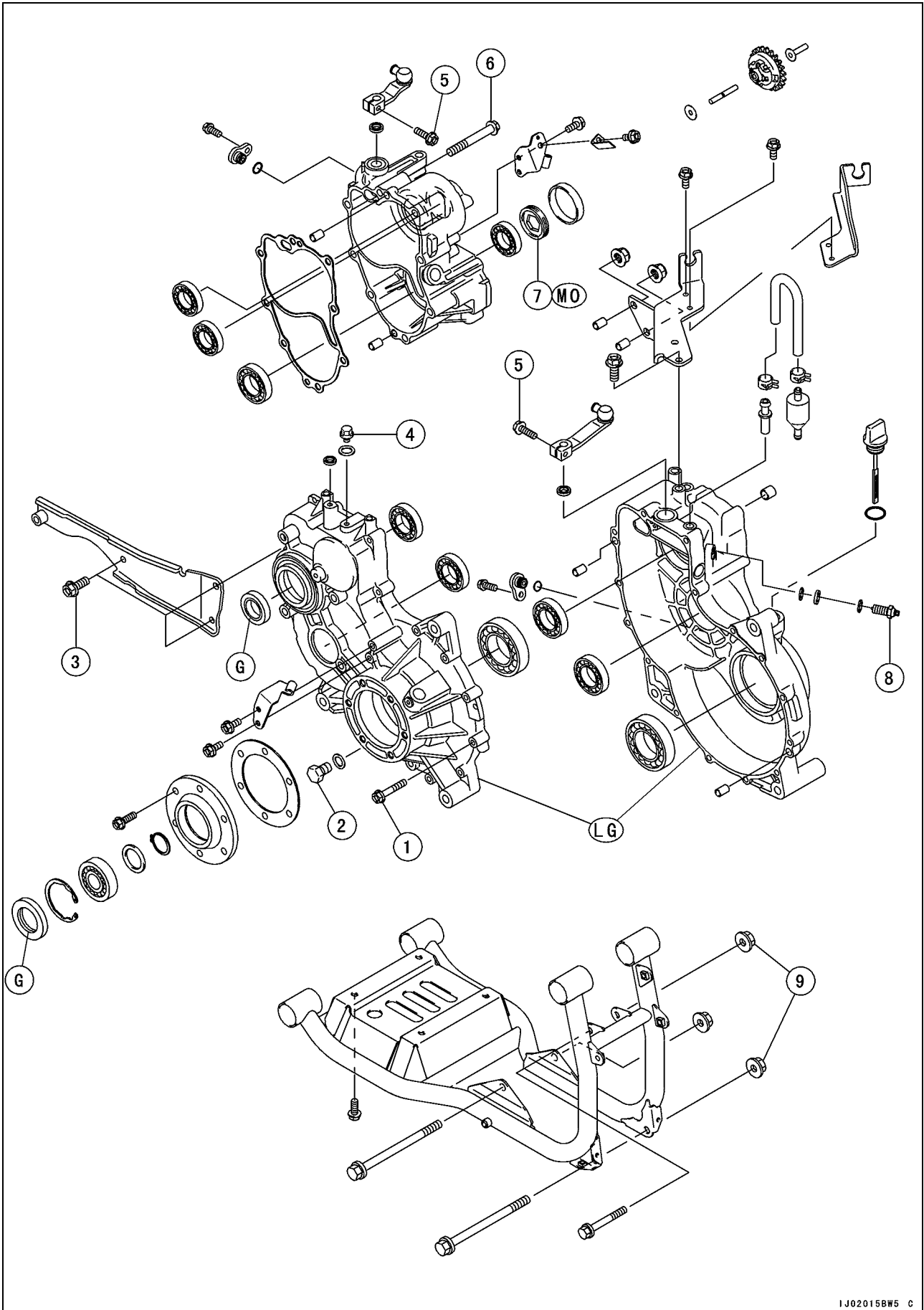

IJ02015BW5 C

**Exploded View**

No.	Fastener	Torque			Remarks
		N-m	kgf-m	ft-lb	
1	Transmission Case Bolts	8.8	0.90	78 in-lb	
2	Transmission Oil Drain Plug	15	1.5	11	
3	Engine Positioning Plate Bolts	20	2.0	14	
4	Governor Pivot Arm Stopper Bolt	15	1.5	11	
5	Shift Shaft Lever Clamp Bolts	12	1.2	104 in-lb	
6	Hi/Low Gear Case Bolts	20	2.0	14	
7	Bearing Holder	120	12	87	MO
8	Neutral Switch	15	1.5	11	
9	Transmission Case Mounting Bolts	44	4.5	33	

G: Apply grease.

LG: Apply liquid gasket.

MO: Apply molybdenum disulfide oil solution (mixture of the engine oil and molybdenum disulfide grease in a weight ratio 10:1).

## 10-8 TRANSMISSION

### Specifications

Item	Standard	Service Limit
<b>Transmission Oil</b>		
Type	API "GL-5" Hypoid gear oil	— — —
Viscosity	SAE 90: above 5°C (41°F)	— — —
	SAE 80: below 5°C (41°F)	— — —
Capacity:	2.5 L (2.6 US qt)	— — —
Oil Level	Between H and L lines on dipstick	— — —
<b>Transmission and Shift Mechanism</b>		
Shift Arm Pin Diameter	7.95 ~ 8.00 mm (0.313 ~ 0.315 in.)	7.8 mm (0.31 in.)
Shifter Block Inside Diameter	8.05 ~ 8.10 mm (0.317 ~ 0.319 in.)	8.2 mm (0.32 in.)
Shifter Block Outside Diameter	13.95 ~ 14.00 mm (0.549 ~ 0.551 in.)	13.8 mm (0.54 in.)
Shifter Groove Width	14.0 ~ 14.2 mm (0.551 ~ 0.559 in.)	14.3 mm (0.563 in.)
Drive Chain 20-Link Length	158.76 ~ 159.18 mm (6.250 ~ 6.267 in.)	161.2 mm (6.35 in.)
<b>Hi/Low Gears And Shift Mechanism</b>		
Shifter Block Outside Diameter	13.95 ~ 14.00 mm (0.549 ~ 0.551 in.)	13.8 mm (0.543 in.)
Shifter Groove Width	14.05 ~ 14.15 mm (0.553 ~ 0.557 in.)	14.3 mm (0.563 in.)
<b>2WD/4WD Shift Mechanism</b>		
Shifter Block Outside Diameter	13.95 ~ 14.00 mm (0.549 ~ 0.551 in.)	13.8 mm (0.543 in.)
Shifter Groove Width	14.0 ~ 14.2 mm (0.551 ~ 0.559 in.)	14.3 mm (0.563 in.)
<b>Differential Gears And Shift Mechanism</b>		
Shift Arm Pin Diameter	8.4 ~ 8.6 mm (0.331 ~ 0.339 in.)	8.3 mm (0.327 in.)
Shifter Groove Width	9.0 ~ 9.1 mm (0.354 ~ 0.358 in.)	9.2 mm (0.362 in.)

**Special Tools and Sealant**

**Outside Circlip Pliers:**  
57001-144

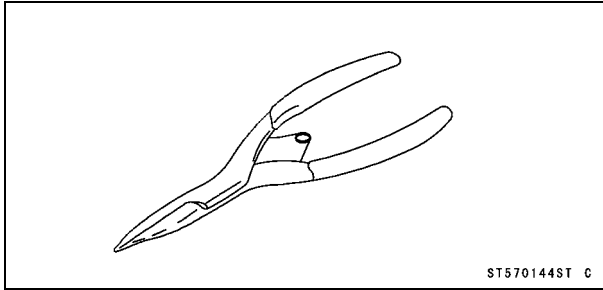

**Hexagon Wrench, Hex 32:**  
57001-1194

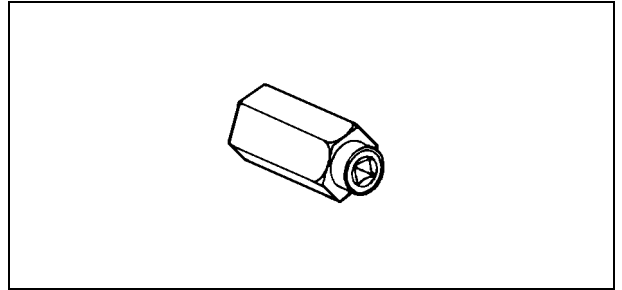

**Oil Seal & Bearing Remover:**  
57001-1058

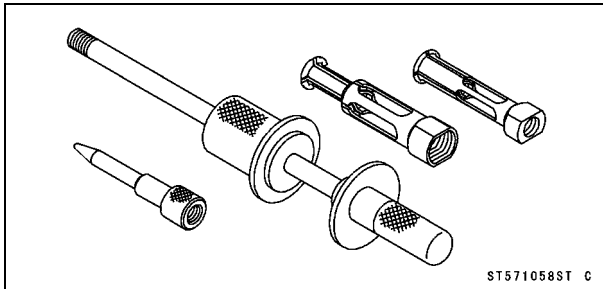

**Kawasaki Bond (Liquid Gasket - Silver):**  
92104-002

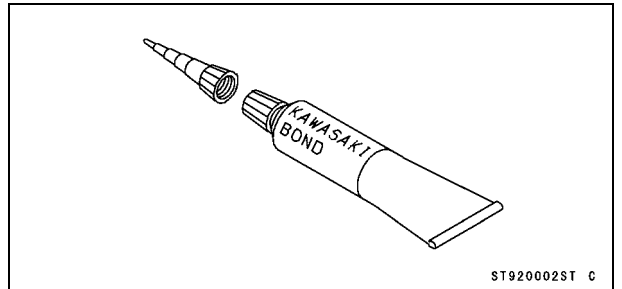

**Bearing Driver Set:**  
57001-1129

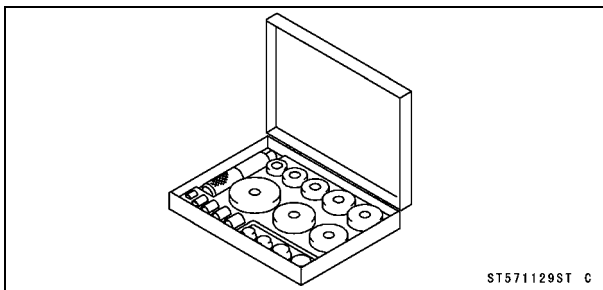

## 10-10 TRANSMISSION

### Transmission Oil

#### CAUTION

Vehicle operation with insufficient, deteriorated or contaminated transmission oil will cause accelerated wear and may result in transmission failure.

#### Transmission Oil Level Inspection

##### NOTE

○ If the vehicle has just been used wait several minutes for all the oil to settle down.

- Park the vehicle on level ground, and tilt up the cargo bed.
- Unscrew the oil filler cap [A], wipe its dipstick [B] dry, and insert it into the filler opening but DO NOT SCREW IT IN.
- Pull out the dipstick and check the oil level. The oil level should be between the upper (H) and lower (L) level lines [C].
- ★ If the oil level is too high, remove the excess oil, using a syringe or some other suitable device, through the oil filler opening.
- ★ If the oil level is too low, add the necessary amount of oil through the oil filler opening. Use the same type and make of oil that is already in the transmission.

##### NOTE

○ If the transmission oil type and make are unknown, use any brand of the specified oil to top up the level in preference to running the transmission with the oil level low. Then, at your earliest convenience, change the oil completely.

#### Transmission Oil Change

- Refer to Transmission Oil Change in the Periodic Maintenance chapter.

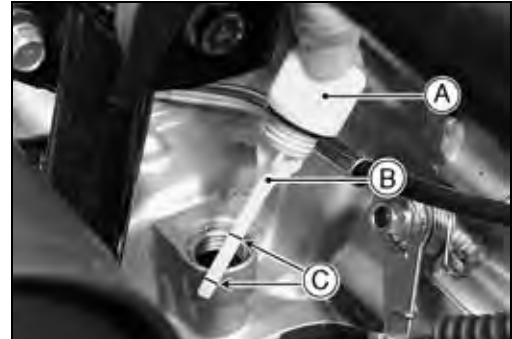

## Transmission Case

### Transmission Case Removal

- Remove:
  - Transmission Oil (drain)
  - Cargo Bed
  - Propeller Shafts (see Final Drive chapter)
  - Torque Converter Case (see Converter System)
  - Drive Shafts and Axles (see Final Drive chapter)
  - Neutral Switch Terminal Lead (disconnect)
  - Transmission Shift Cable Lower End [A]
  - Hi/Low Shift Cable Lower End [B]
  - 2WD/4WD Shift Cable Lower End [C]
  - Differential Shift Cable Lower End [D]
  - Throttle Cable Lower End [E]
  - Governor Arm [F]
  - Control Panel Assembly [G]
  - Cable Bracket Mounting Bolts and Collars
  - Engine Positioning Plate [H]
  
- Transmission Case Mounting Bolts and Nuts [A]
- Transmission Case [B]

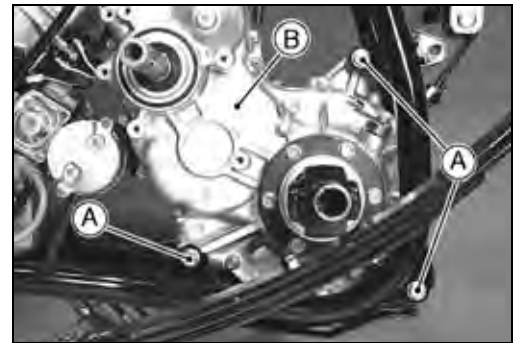
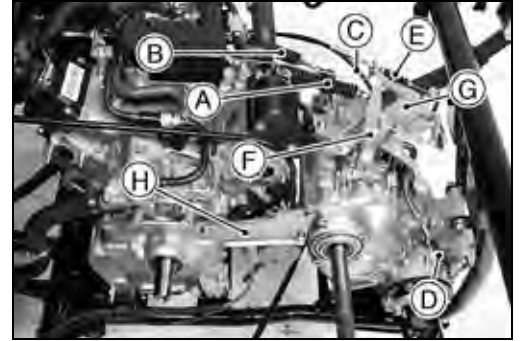

### Transmission Case Installation

- Tighten:
  - Torque - Transmission Case Mounting Bolts: 44 N·m (4.5 kgf·m, 33 ft·lb)**
  
- Install (Optional Parts):
  - Speedometer Gear [A]
  - Washer [B]
  - O-ring [C]
  - Bushing [D]
  - Oil Seal [E]
  - Thick Holder [F]
  - Thin Holder [G]
  - Bolt [H]
  
- Adjust:
  - Engine Mounting Position (see Engine Installation)
  - Transmission Oil
  - Transmission Shift Cable
  - Differential Shift Cable
  - Hi/Low Shift Cable
  - 2WD/4WD Shift Cable
  - Throttle Pedal Free Play

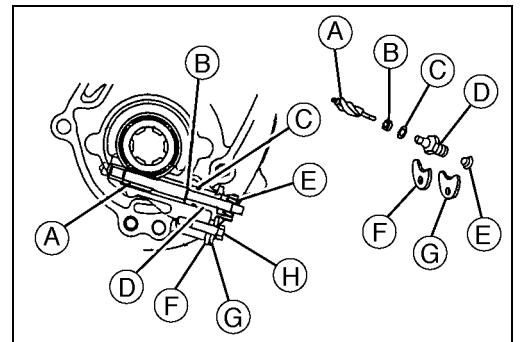

## 10-12 TRANSMISSION

### Transmission Case

#### Transmission Case Splitting

- Remove:
  - Cable Bracket
  - Transmission Case Bolts [A]
  - Transmission Case (Left) [B]

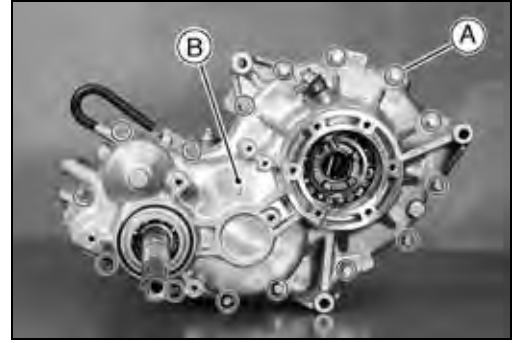

#### Transmission Case Assembly

- Check to see that the transmission case knock pins [A] are in place. If any one of them has been removed, replace it with a new one.
- Apply liquid gasket:
  - Transmission Case Mating Surface
  - Sealant - Kawasaki Bond (Liquid Gasket - Silver): 92104 - 002**
- Apply grease:
  - Oil Seal Lips
- Check that the governor shaft [A] is turned clockwise.
- Turning the drive shaft [B], engage the governor drive gear [C] with the governor gear [D].

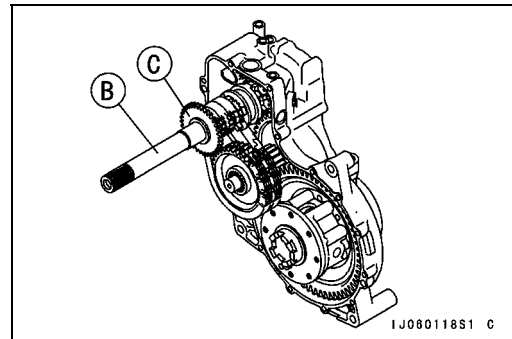
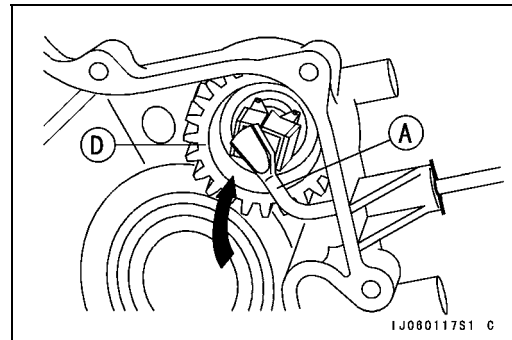
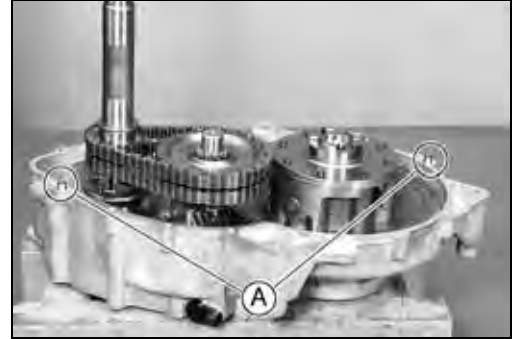

- Tighten:
  - Torque - Transmission Case Bolts: 8.8 N·m (0.90 kgf·m, 78 in·lb)



**Transmission and Shift Mechanism**

*Transmission and Hi/Low Shift Cables Installation*

- Remove one side of the spring [A] from the shift shaft lever assembly.

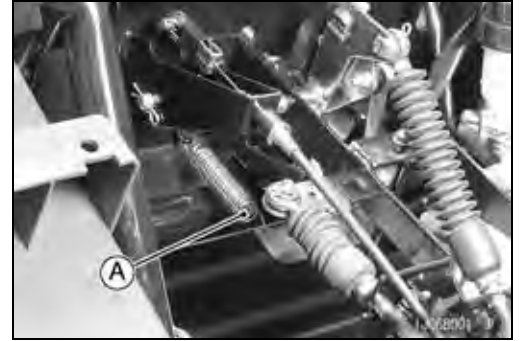

- Put the shift lever [A] in the "L" (LOW) position.



- Using the shift shaft lever [B] temporarily set the shift arm [A] in forward or reverse position as shown.



- Put the differential shift lever [A] in "LOCK" position.



- Turn the hi/low shift shaft lever [A] clockwise while turning the drive shafts (wheels) until the lever engages low gear.



## 10-14 TRANSMISSION

### Transmission and Shift Mechanism

- Screw the joint [A] of the shift shaft lever [B] fully into the hi/low shift cable [C] end, and install the cable onto the bracket [D].

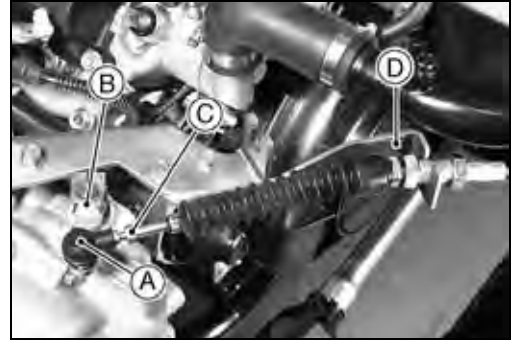

- Line up the punch mark [A] on the shift arm, projection [B] on the transmission case and slit opening in the shift shaft lever [C].
- Tighten:
  - Shift Shaft Lever Nut [D]
  - Shift Shaft Lever Clamp Bolt [E]

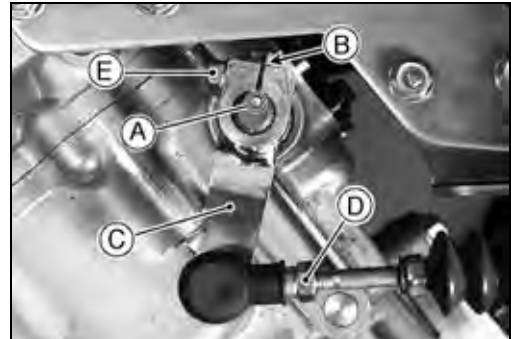

- Hold the shift shaft lever [A] in the low range position turning fully clockwise, and then push the outer cable [B] lightly rearward to remove the cable free play.
- Tighten:
  - Hi/Low Shift Cable Adjuster Nut [C]
  - Hi/Low Shift Cable Adjuster Nut [D]

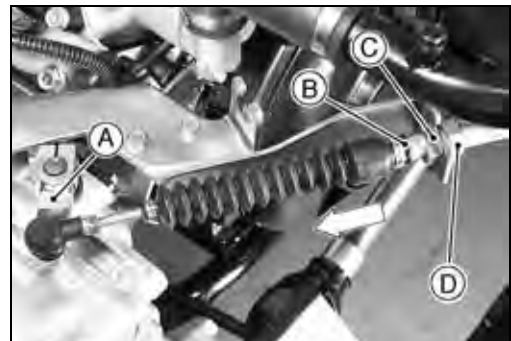

- Put the shift lever [A] in the center of right and left at "N" (NEUTRAL) position, and hold it at the location [B].
- Install suitable plates [C] between the shift lever and lower and upper side of the gate in order to fix the shift lever.



- Using the shift shaft lever [B] temporarily set the shift arm [A] in neutral position as shown.

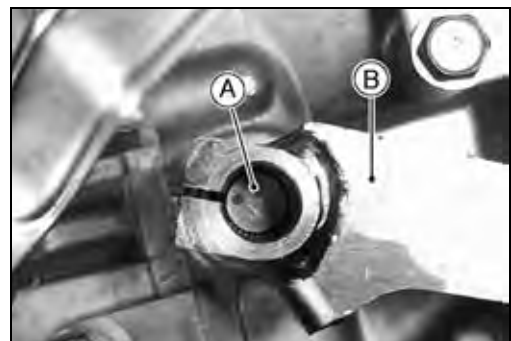

**Transmission and Shift Mechanism**

- Screw the joint [A] of the shift shaft lever [B] fully into the transmission shift cable [C] end, and install the cable onto the bracket [D].

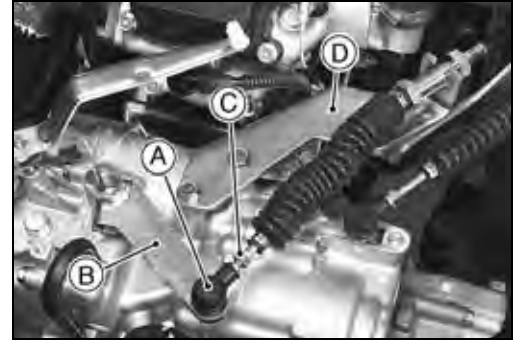

- Line up the punch mark [A] on the shift arm, projection [B] on the transmission case and slit opening in the shift shaft lever [C].
- Tighten:
  - Shift Shaft Lever Nut [D]
  - Shift Shaft Lever Clamp Bolt [E]



- Hold the shift shaft lever [A] in the neutral position, and then pull the outer cable [B] lightly forward to remove the cable free play.

**NOTE**

○ If the cable cannot be adjusted, move the slit opening in the shift shaft lever one notch to right side of the punch mark on the shift arm.

- Tighten:
  - Transmission Shift Cable Adjuster Nut [C]
  - Transmission Shift Cable Adjuster Nut [D]

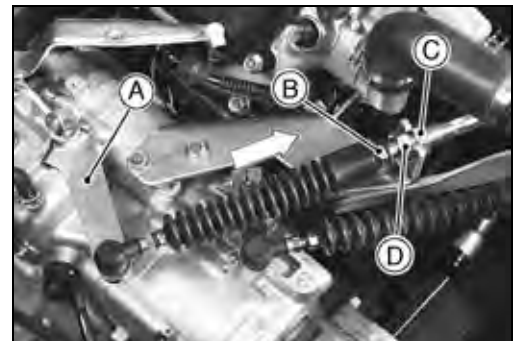

- Install the spring [A] back onto the shift shaft lever assembly.

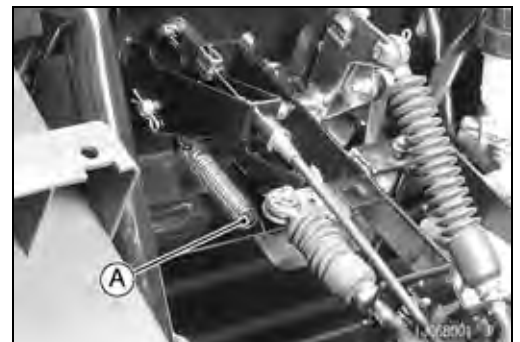

- Check the shift lever position (see Shift Lever Position Inspection).

## 10-16 TRANSMISSION

### Transmission and Shift Mechanism

#### Shift Lever Position Inspection

- Start the engine and put the shift lever in "N" (NEUTRAL) or "L" (LOW) position.
- Move the shift lever [A] slowly to the direction of the arrow on the figure. At this time, increase the engine speed slightly.
- Check the grinding noise at the specified positions [B] and [C].
- ★ If the position of the grinding noise is far from the specified position, adjust the shift lever position (see Shift Lever Position Adjustment).

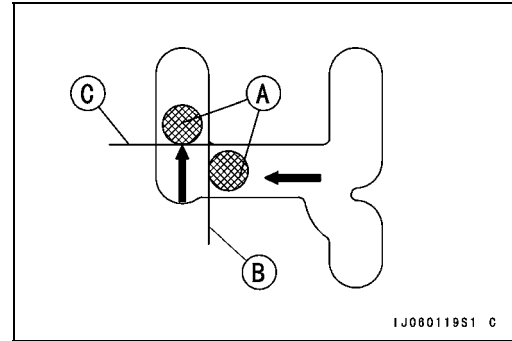

#### Shift Lever Position Adjustment

- Loosen the hi/low shift cable adjuster nuts [A] and [B].

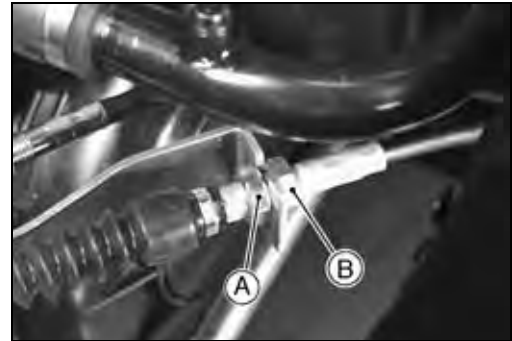

- Adjust the hi/low shift cable and set the transmission shift lever [A] in the correct position as follows.
- The gap [B] between the shift lever and panel is approximate 1.5 mm (0.06 in.).
- When the outer cable moving forward, the shift lever moves left side.
- When the outer cable moving rearward, the shift lever moves right side.
- Tighten:  
Hi/Low Shift Cable Adjuster Nuts

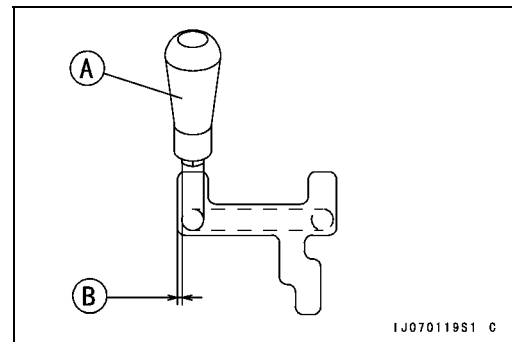

- Loosen the transmission shift cable adjuster nuts [A] and [B].

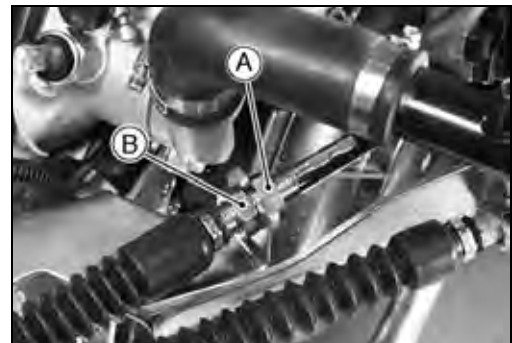

- Adjust the transmission shift cable and set the transmission shift lever [A] in the correct position as follows.
- When the shift lever moving to right and left, the gaps between [B] and [C] are same.
- When the outer cable moving forward, the shift lever moves upward.
- When the outer cable moving rearward, the shift lever moves downward.
- Tighten:  
Transmission Shift Cable Adjuster Nuts

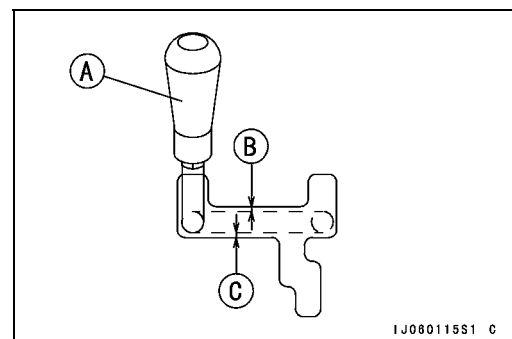

**Transmission and Shift Mechanism**

*Transmission Shift Cable Inspection*

- With the cable disconnected at both ends, the cable should move freely within the cable housing.
- ★ If the cable movement is not free, if the cable is frayed, or if the housing is kinked, replace the cable.



*Transmission Removal*

- Remove:
  - Hi/Low Shift Gears (see Hi/Low Gear and Shift Mechanism Removal)
  - 2WD/4WD Shift Mechanism (see 2WD/4WD Shift Mechanism Removal)
  - Transmission Case (see Transmission Case Splitting)
  - Drive Shaft [A]
  - Drive Shaft Reverse Sprocket [B]
  - Drive Chains [C]

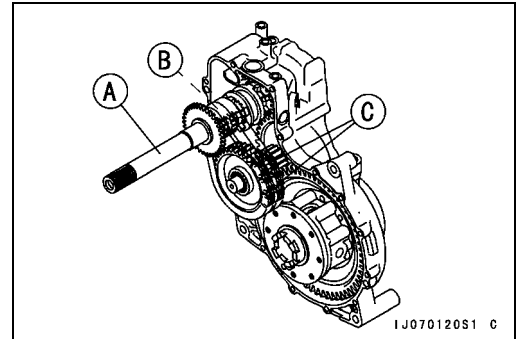

- Remove:
  - Shift Arm Positioning Bolt Assembly [A]
  - Retaining Pin [B]
- Lift the shift arm [C] and remove the shifter block [D].
- Remove:
  - Shifter [E]

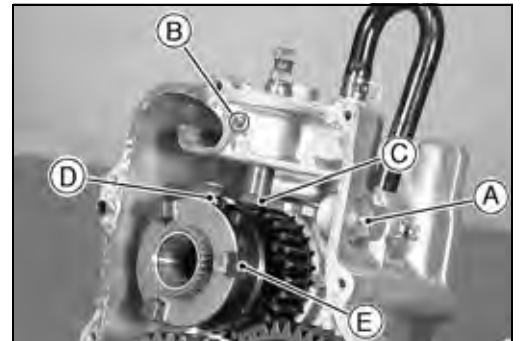

- Remove:
  - Drive Shaft (Outer) [A] and Drive Shaft Forward Gear [B]
  - Shift Arm [C]
  - Differential Gear Assembly [D]
  - Driven Shaft Assembly [E]

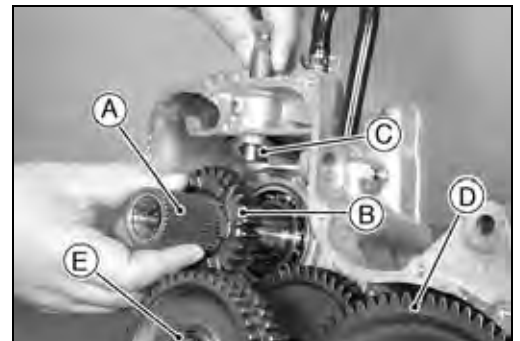

- Remove:
    - Circlip [A]
    - Washer [B]
    - Governor Drive Gear [C]
    - Pin
    - Drive Shaft [D]
- Special Tool - Outside Circlip Pliers: 57001-144**

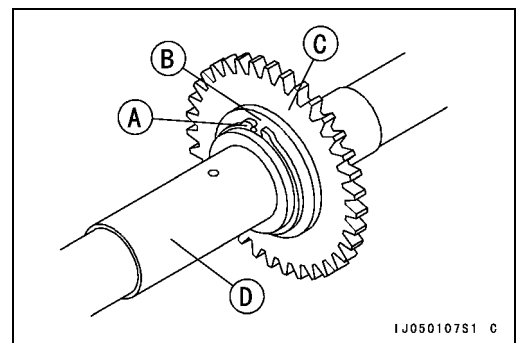

## 10-18 TRANSMISSION

### Transmission and Shift Mechanism

- Remove:
  - Circlips [A]
  - Driven Shaft Reverse Sprocket [B]
  - Driven Shaft Forward Gear [C]
  - Driven Shaft [D]

**Special Tool - Outside Circlip Pliers: 57001-144**

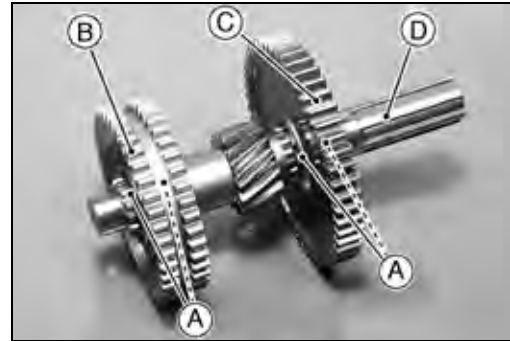

#### Transmission Installation

- Replace all circlips that were removed with new ones.

#### NOTE

○ Always install circlips [A] so that the opening [B] is aligned with a spline groove. To install a circlip without damage, first fit the circlip onto the shaft [C] and then expand it just enough to install. Hence, use a suitable gear to push the circlip into place.

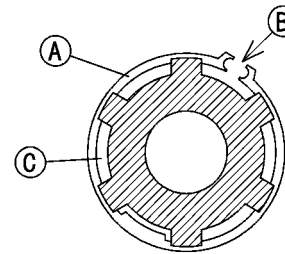

61130113S1 C

- Apply transmission oil:
  - Drive and Driven Shafts
  - Forward Gears
  - Reverse Sprockets
  - Drive Chains
- Apply grease:
  - Oil Seal Lips
  - Shift Arm Positioning Ball and Spring
- Install the shifter [A] so that the groove [B] is away from the forward gear [C].
- Tighten:
  - Torque - Shift Arm Positioning Bolt: 37 N·m (3.8 kgf·m, 27 ft·lb)
- Install the governor drive gear [A] so that the chamfered side [B] faces to the flange [C].
- Check that each gear, sprocket, and shifter spins or slides freely on its shaft without binding after assembly.

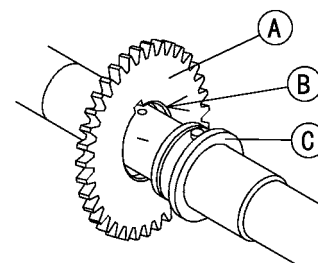
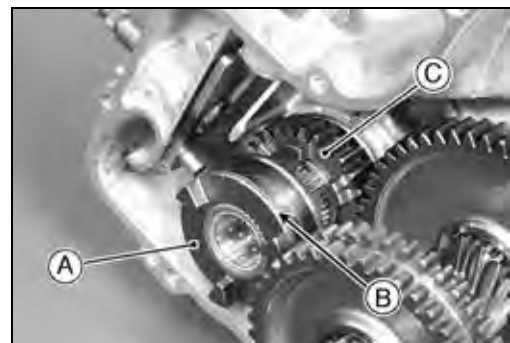

1J050108S1 C

**Transmission and Shift Mechanism**

*Transmission and Shift Mechanism Inspection*

- Visually inspect the forward gears, reverse sprockets, gear and shaft bushings [A], drive chains, and shifter.
- Replace parts worn beyond the service limit.

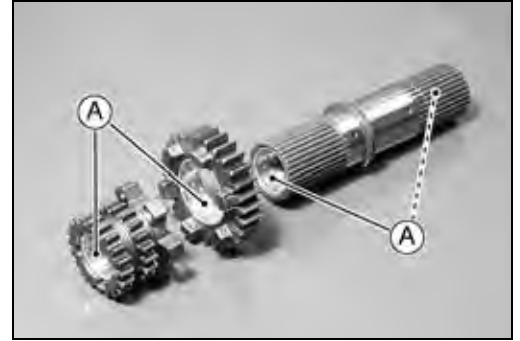

**Shift Arm Pin Diameter [A]**

**Standard:** 7.95 ~ 8.00 mm (0.313 ~ 0.315 in.)

**Service Limit:** 7.8 mm (0.31 in.)

**Shifter Block Inside Diameter [B]**

**Standard:** 8.05 ~ 8.10 mm (0.317 ~ 0.319 in.)

**Service Limit:** 8.2 mm (0.32 in.)

**Shifter Block Outside Diameter [C]**

**Standard:** 13.95 ~ 14.00 mm (0.549 ~ 0.551 in.)

**Service Limit:** 13.8 mm (0.54 in.)

**Shifter Groove Width [D]**

**Standard:** 14.0 ~ 14.2 mm (0.551 ~ 0.559 in.)

**Service Limit:** 14.3 mm (0.563 in.)

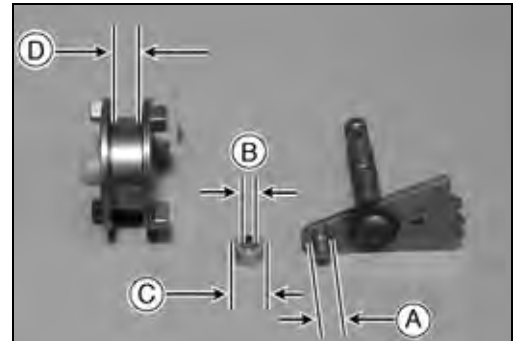

**Drive Chain 20-Link Length [B]**

**Standard:** 158.76 ~ 159.18 mm (6.250 ~ 6.267 in.)

**Service Limit:** 161.2 mm (6.35 in.)

- A : Force
- C : 1st Pin
- D : 2nd Pin
- E : 21th Pin

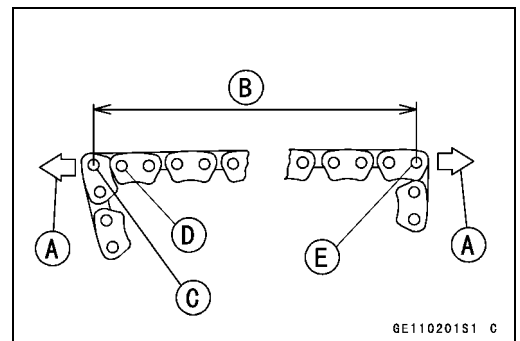

## 10-20 TRANSMISSION

### Hi/Low Gears and Shift Mechanism

#### Hi/Low Shift Cable Installation

- See Transmission and Hi/Low Shift Cables Installation.

#### Hi/Low Shift Cable Inspection

- With the cable disconnected at both ends, the cable should move freely within the cable housing.
- ★ If the cable movement is not free, if the cable is frayed, or if the housing is kinked, replace the cable.

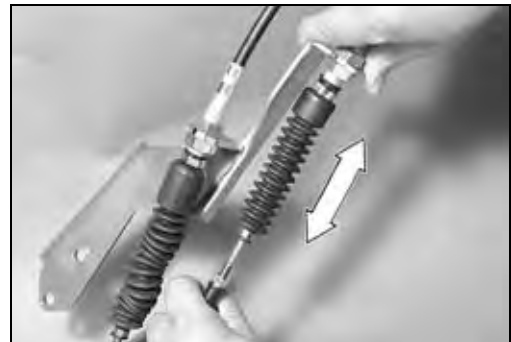

#### Hi/Low Gear and Shift Mechanism Removal

- Remove:
  - Bevel Gear Case (see Final Drive chapter)
  - Hi/Low Shift Shaft Lever [A]
  - 2WD/4WD Shift Cable Lower End [B]



- Remove:
  - Hi/Low Gear Case Bolts [A]
  - Hi/Low Gear Case [B]



- Remove:
  - Washer [A]
  - High Gear [B]
  - Shifter [C]
  - Reduction Gear [D]

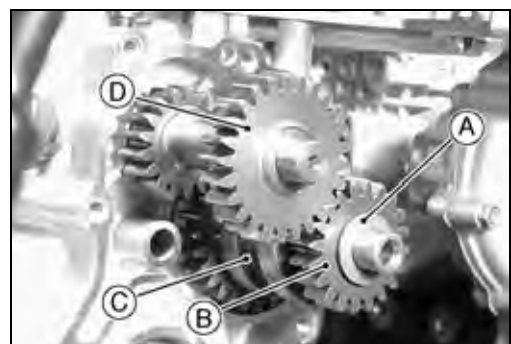



**Hi/Low Gears and Shift Mechanism**

- Remove:
  - Circlip [A]
  - Washer [B]
  - Low Gear [C]
  - Collar

**Special Tool - Outside Circlip Pliers: 57001-144**

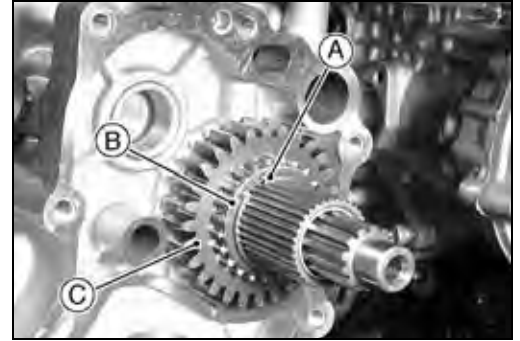

- Remove:
  - Bolt [A]
  - Holder [B]

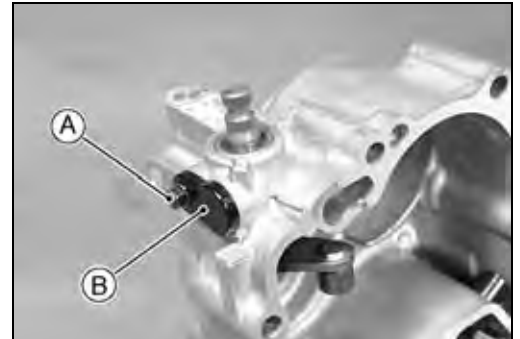

- Remove:
  - Retaining Pin [A]
  - Shift Shaft and Arm [B]

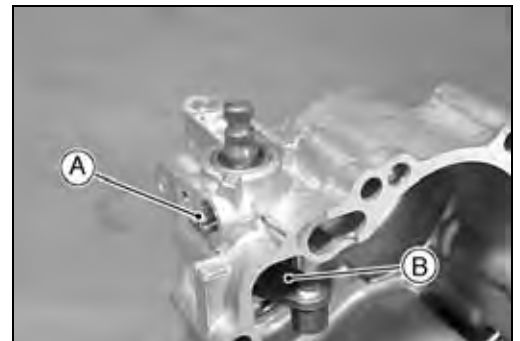

*Hi/Low Gear and Shift Mechanism Installation*

- Apply transmission oil:
  - Hi/Low Gears
  - Shifter
- Apply grease:
  - Oil Seal Lips
- Replace the circlip that was removed with a new one.

**NOTE**

○ Always install the circlip [A] so that the opening [B] is aligned with a spline groove. To install a circlip without damage, first fit the circlip onto the shaft [C] and then expand it just enough to install. Hence, use a suitable gear to push the circlip into place.

- Install the shifter [A] so that the large dogs [B] face to the low gear [C].

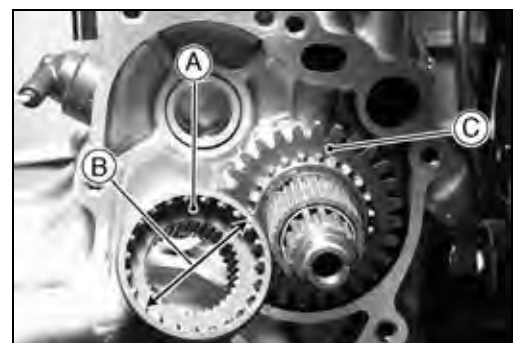
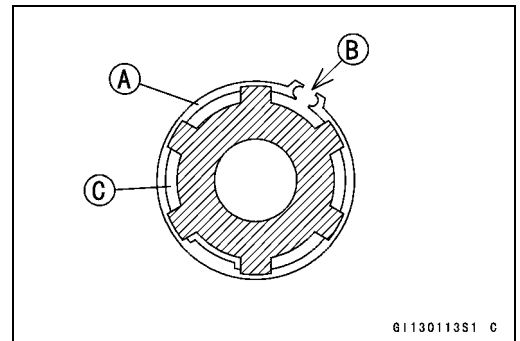

## 10-22 TRANSMISSION

### Hi/Low Gears and Shift Mechanism

- Install:
  - Reduction Gear [A]
  - High Gear [B]
  - Washer [C]
  - Shifter [D]
- Check to see that the hi/low gear case knock pins [E] are in place on the transmission case. If any one of them has been removed, replace it with a new one.

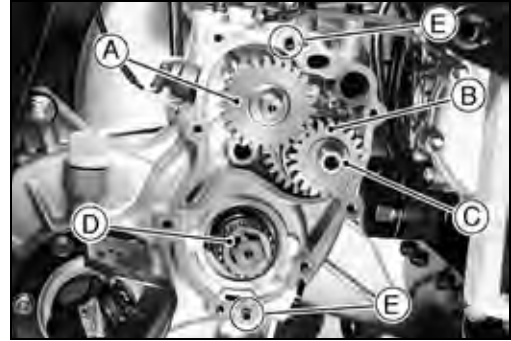

- Fit the shift arm pins [A] into the shifter grooves [B].
- Tighten:
  - Torque - Hi/Low Gear Case Bolts: 20 N·m (2.0 kgf·m, 14 ft·lb)**
- Check that each gear and shifter spins or slides freely on its shaft without binding after assembly.

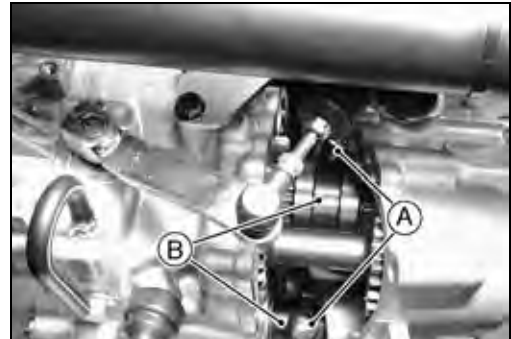

#### *Hi/Low Gear and Shift Mechanism Inspection*

- Visually inspect the hi/low gears, shifter, and low gear bushing [A].

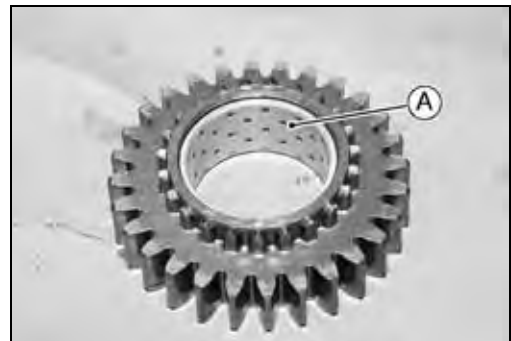

#### **Shifter Block Outside Diameter [A]**

**Standard:** 13.95 ~ 14.00 mm (0.549 ~ 0.551 in.)

**Service Limit:** 13.8 mm (0.543 in.)

#### **Shifter Groove Width [B]**

**Standard:** 14.05 ~ 14.15 mm (0.553 ~ 0.557 in.)

**Service Limit:** 14.3 mm (0.563 in.)

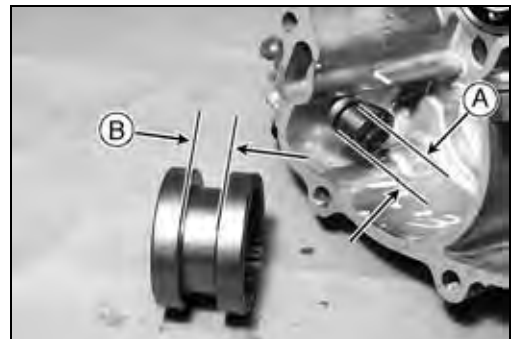

## 2WD/4WD Shift Mechanism

### 2WD/4WD Shift Cable Adjustment

- Put the shift lever [A] in the 2WD position.



- Install the 2WD/4WD shift cable [A] to the shift shaft lever [B] and cable bracket [C].

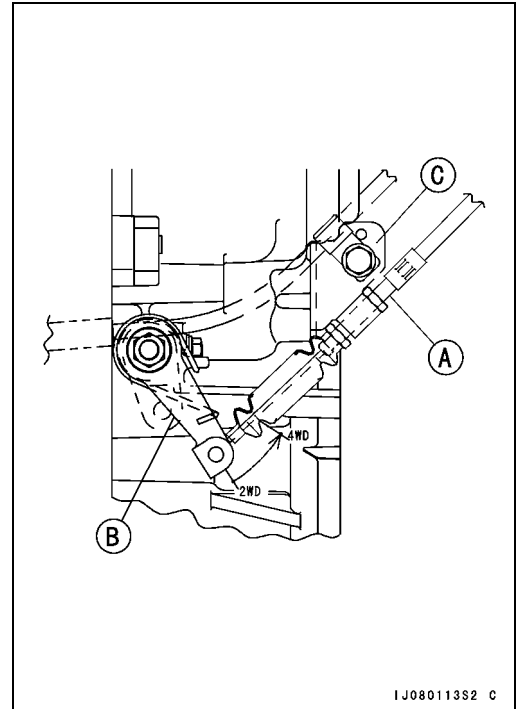

- Put the shift lever [A] in the 4WD position.



- Turn the shift shaft lever [A] counterclockwise until the lever is stopped by engaging the shifter with the drive bevel gear shaft.
- Screw in the upper adjuster nut [B] by hand until the inner cable [C] has no slack while holding the shift lever in the 4WD position.
- Tighten the lower adjuster nut [D] securely.

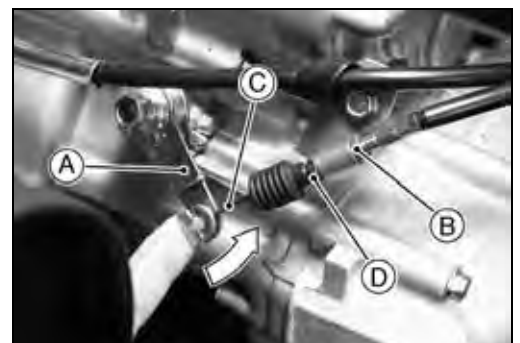

## 10-24 TRANSMISSION

### 2WD/4WD Shift Mechanism

#### NOTE

○ If the 2WD/4WD shift cable cannot be adjusted by using the adjuster at the shift shaft lever, use the adjuster [A] at the shift lever. Do not forget to tighten the adjuster nuts [B].

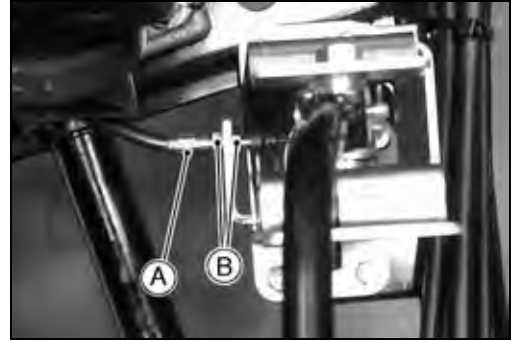

#### 2WD/4WD Shift Cable Lubrication

Whenever the shift cable is removed, lubricate the cable as follows.

- Apply a thin coating of grease to the cable ends.
- Lubricate the cable with a penetrating rust inhibitor through the pressure cable luber.

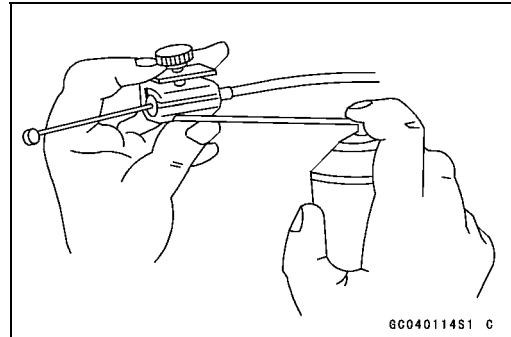

#### 2WD/4WD Shift Cable Inspection

- With the cable disconnected at both ends, the cable should move freely [A] within the cable housing.
- ★ If the cable movement is not free, if the cable is frayed, or if the housing is kinked, replace the cable.

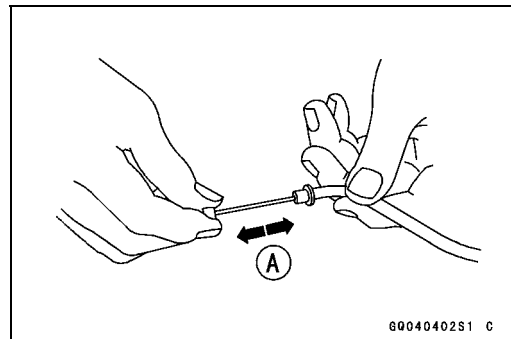

#### 2WD/4WD Shift Mechanism Removal

- Remove:
  - Hi/Low Gear Case (see Hi/Low Gear and Shift Mechanism Removal)
  - Shift Shaft Stop Bolt [A]



- Remove:
  - Shift Shaft Lever Mounting Nut [A]
  - Shift Shaft Lever [B]
  - Spring [C]
  - Shift Shaft and Arm [D]

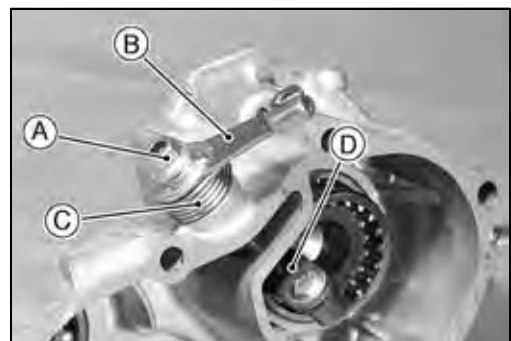

**2WD/4WD Shift Mechanism**

- Remove:
  - Shifter [A]
  - Circlip [B]
  - Speedometer Gear [C]
  - Collar

**Special Tool - Outside Circlip Pliers: 57001-144**

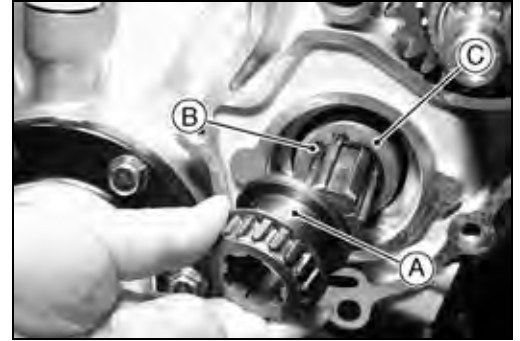

*2WD/4WD Shift Mechanism Installation*

- Apply grease:
  - Shift Shaft O-ring
- Install the shift shaft lever [A] to the shift shaft arm [B] as shown.

**Torque - Shift Shaft Stop Bolt: 7.8 N-m (0.80 kgf-m, 69 in-lb)**

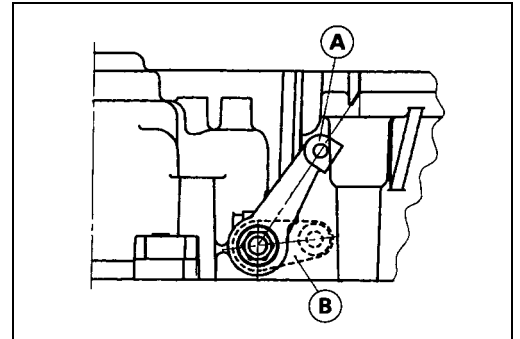

- Install:
  - Collar [A]
- Install the speedometer gear [B] so that the stepped side [C] faces in.



- Replace the circlip that was removed with a new one.

**NOTE**

○ Always install the circlip [A] so that the opening [B] is aligned with a spline groove. To install a circlip without damage, first fit the circlip onto the shaft [C] and then expand it just enough to install. Hence, use a suitable gear to push the circlip into place.

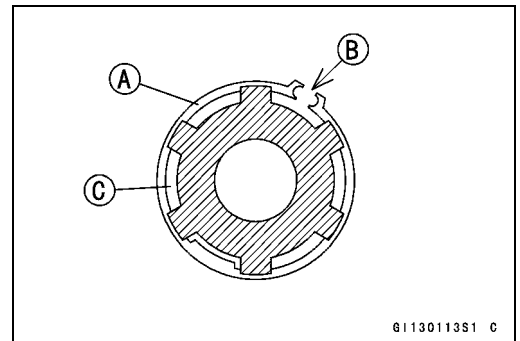

*2WD/4WD Shift Mechanism Inspection*

- Visually inspect:
  - Dogs on Shifter [A]
  - Shifter Groove [B]
  - Dogs on Drive Bevel Gear Shaft [C]
  - Shifter Block [D]
- ★ If they are damaged or worn excessively, replace them.

**Shifter Block Outside Diameter**

- Standard:** 13.95 ~ 14.00 mm (0.549 ~ 0.551 in.)
- Service Limit:** 13.8 mm (0.543 in.)

**Shifter Groove Width**

- Standard:** 14.0 ~ 14.2 mm (0.551 ~ 0.559 in.)
- Service Limit:** 14.3 mm (0.563 in.)

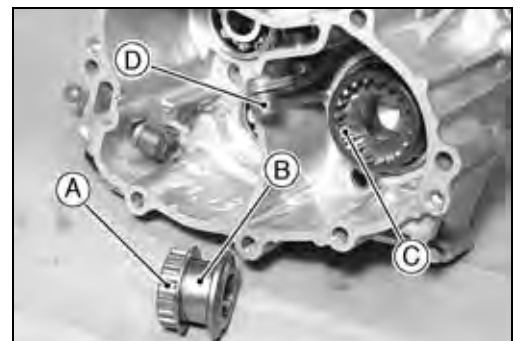

6113011351 C

## 10-26 TRANSMISSION

### Differential Gears and Shift Mechanism

#### Differential Shift Cable Adjustment

- Put the shift lever [A] in the UNLOCK position.



- Set the shift shaft lever [A] in the UNLOCK position.
- Loosen the adjuster nut [B] until the inner cable is slightly loosened.
- Tighten the adjuster nut [C] securely.

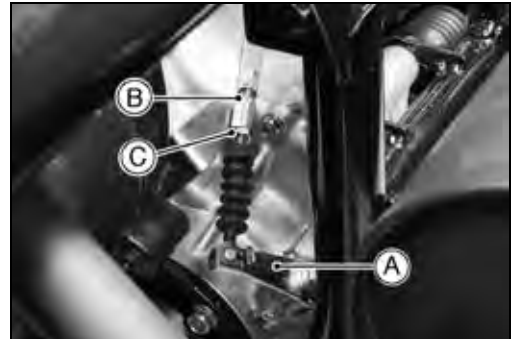

#### Differential Shift Cable Lubrication

Whenever the shift cable is removed, lubricate the cable as follows.

- Apply a thin coating of grease to the cable ends.
- Lubricate the cable with a penetrating rust inhibitor through the pressure cable luber.

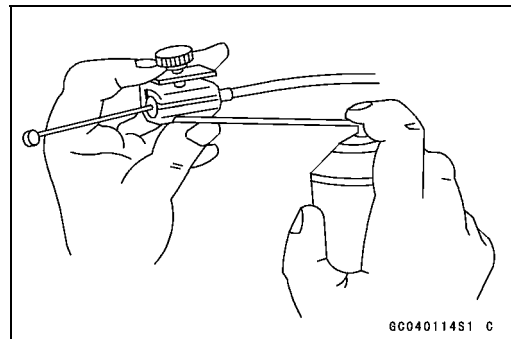

#### Differential Shift Cable Inspection

- With the cable disconnected at both ends, the cable should move freely [A] within the cable housing.
- ★ If the cable movement is not free, if the cable is frayed, or if the housing is kinked, replace the cable.

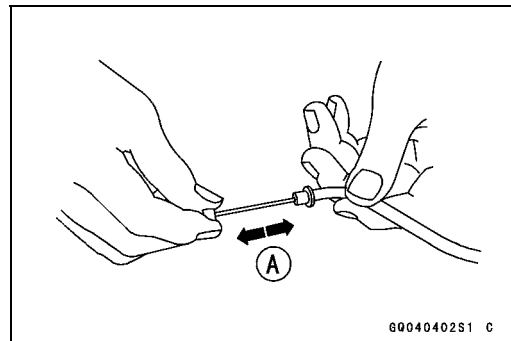

#### Differential Shift Mechanism Removal

- Remove:
  - Drive Shafts and Axles
  - Shift Shaft Stop Bolt [A]
  - Shift Shaft Lever Mounting Nut [B]
  - Shift Shaft Lever [C]
  - Spring [D]
  - Shift Shaft and Arm [E]

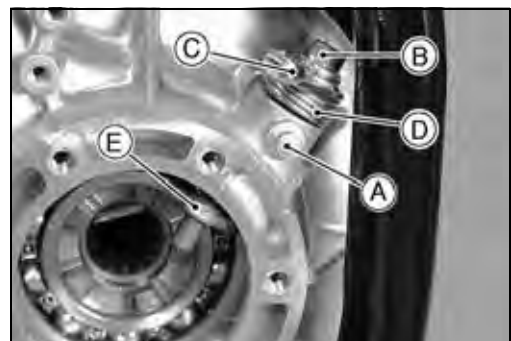

**Differential Gears and Shift Mechanism**

*Differential Shift Mechanism Installation*

- Apply grease:  
Shift Shaft O-ring
- Install the shift shaft lever [A] to the shift arm [B] as shown.  
**Torque - Shift Shaft Stop Bolt: 7.8 N·m (0.80 kgf·m, 69 in·lb)**

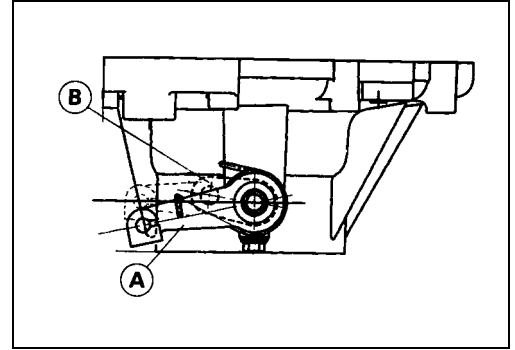

*Differential Shift Mechanism Inspection*

- Visually inspect:  
Splines on Drive Shaft [A]  
Splines on Shifter [B]  
Dogs on Shifter  
Shifter Groove
  
- Visually inspect:  
Shift Arm Pin [A]  
Dogs on Differential Gear Housing [B]

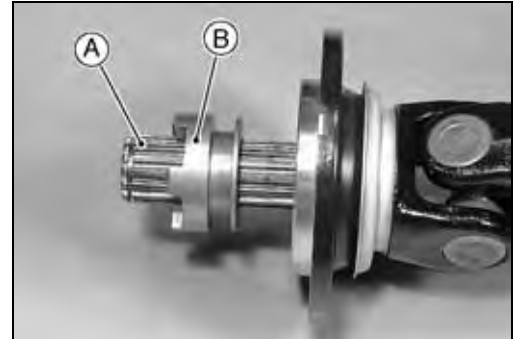

★ If they are damaged or worn excessively, replace them.

**Shift Arm Pin Diameter [A]**

- Standard:** 8.4 ~ 8.6 mm (0.331 ~ 0.339 in.)
- Service Limit:** 8.3 mm (0.327 in.)

**Shifter Groove Width [B]**

- Standard:** 9.0 ~ 9.1 mm (0.354 ~ 0.358 in.)
- Service Limit:** 9.2 mm (0.362 in.)



*Differential Gear Removal*

- Remove:  
Transmission Case (split)  
Differential Gear Assembly [A]



## 10-28 TRANSMISSION

### Differential Gears and Shift Mechanism

- Remove:
  - Differential Gear Housing Bolts [A]
  - Final Gear [B]



- Remove:
  - Housing Cover [A]
  - Knock Pin [B]
  - Side Gear [C]
  - Spacer [D]

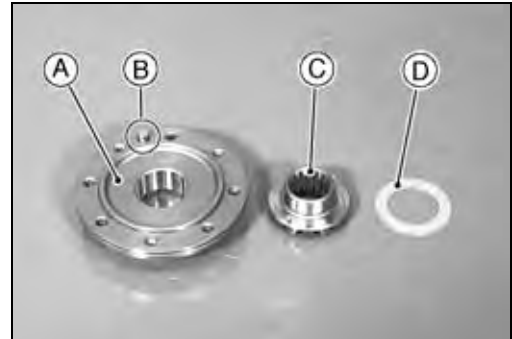

- Remove:
  - Knock Pins [A]
  - Retaining Pin [B]
  - Pinion Gear Shaft [C]
  - Pinion Gears [D]
  - Spacers
  - Side Gear [E]
  - Spacer

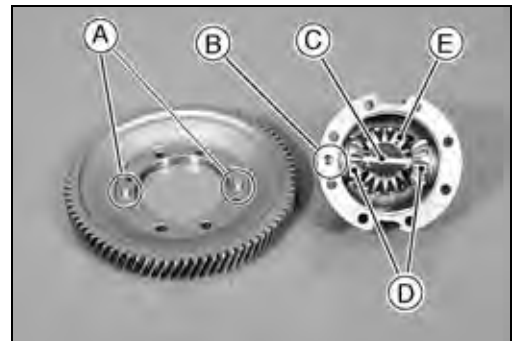

#### *Differential Gear Installation*

- Apply transmission oil:
  - Side Gears
  - Pinion Gears
- Apply a non-permanent locking agent:
  - Differential Gear Housing Bolts
- Tighten:
  - Torque - Differential Gear Housing Bolts: 57 N·m (5.8 kgf·m, 42 ft·lb)**

#### *Differential Gear Inspection*

- Visually inspect the differential gears [A].
- ★ Replace the gears as a set if either gear is damaged.

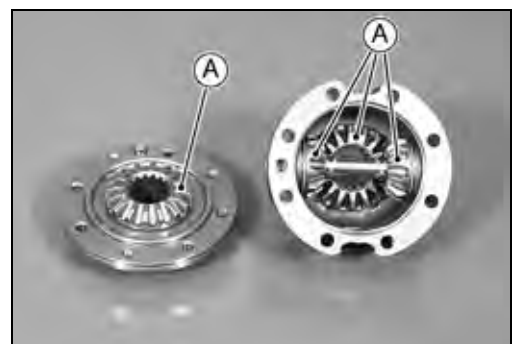



## Bearings and Oil Seal

### *Bearing Replacement*

- Using a press, a puller, the oil seal & bearing remover, or the bearing driver set, remove the bearings.

**Special Tools - Oil Seal & Bearing Remover: 57001-1058**  
**Bearing Driver Set: 57001-1129**

- Using the hexagon wrench [A], remove the bearing holder [B] and remove the drive bevel gear shaft bearing.

**Special Tool - Hexagon Wrench, Hex 32: 57001-1194**

- Apply oil:  
 Drive Bevel Gear Shaft Bearing Holder

- Tighten:

**Torque - Bearing Holder: 120 N·m (12 kgf·m, 87 ft·lb)**

- Using a press and the bearing driver set, install the new bearings and/or new oil seals.

**Special Tool - Bearing Driver Set: 57001-1129**



### *Ball Bearing Inspection*

- Examine the bearing seal [B] for tears or leakage.
- ★ If the seal is torn or is leaking, replace the bearing.
- Turn [A] each bearing back and forth while checking for roughness or binding.
- ★ If roughness or binding is found, replace the bearing.

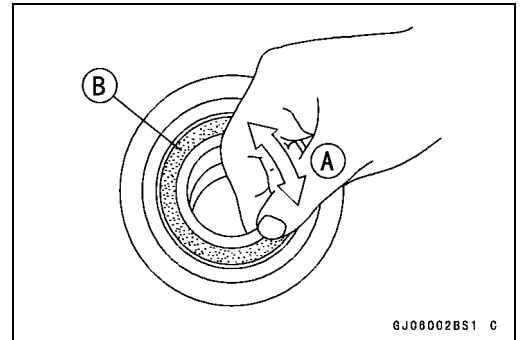

### *Needle Bearing Inspection*

- Check the needle bearing.
- The rollers in a needle bearing normally wear very little, and wear is difficult to measure. Instead of measuring, inspect the bearing for abrasion, color change, or other damage.
- ★ If there is any doubt as to the condition of a needle bearing, replace it.

### *Oil Seal Inspection*

- Visually inspect the oil seal.
- ★ Replace it if the lips are misshapen, discolored (indicating that the rubber has deteriorated), hardened, or been otherwise damaged.

# 10-30 TRANSMISSION

## Transmission Sectional Figure

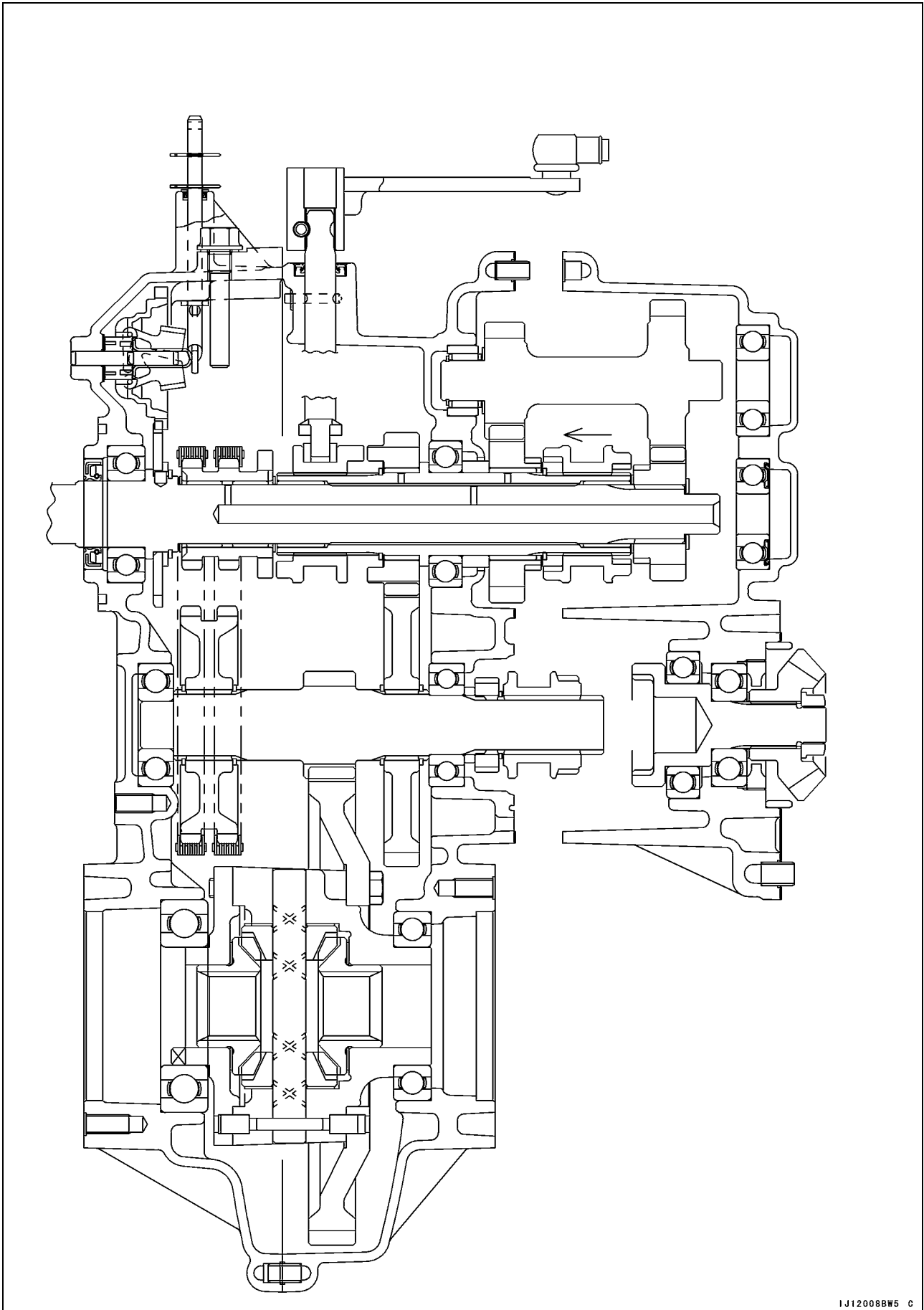

IJ12008BW5 C

Transmission Sectional Figure

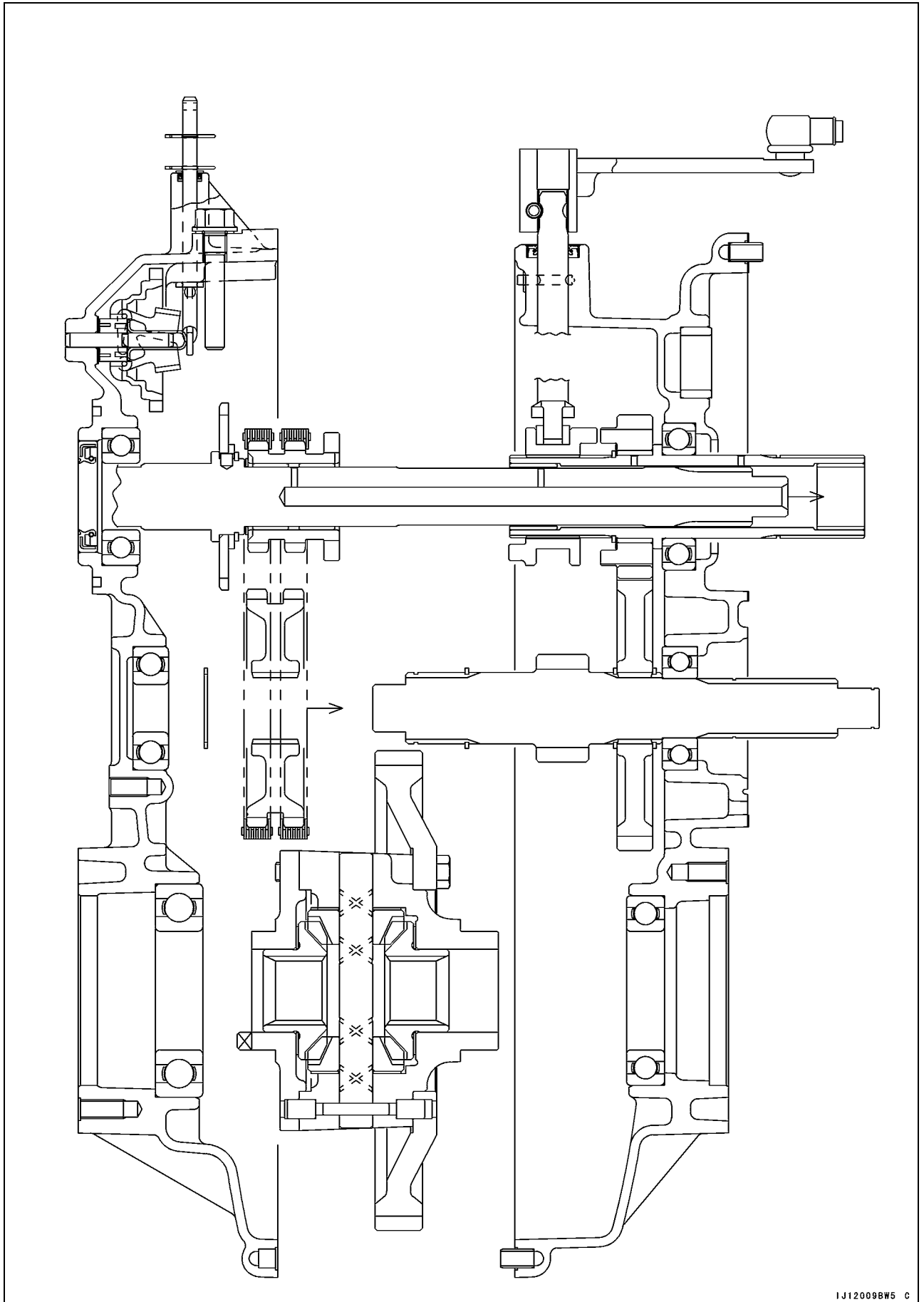

IJ120098W5 C



# Wheels/Tires

## Table of Contents

Exploded View .....	11-2
Specifications .....	11-4
Wheel Alignment .....	11-5
Toe-in Adjustment .....	11-5
Wheels (Rims) .....	11-7
Wheel Removal.....	11-7
Wheel Installation.....	11-7
Wheel (Rim) Inspection.....	11-7
Wheel (Rim) Replacement.....	11-7
Tires .....	11-9
Tire Removal .....	11-9
Tire Installation .....	11-9
Tire Inspection .....	11-10

# 11-2 WHEELS/TIRES

## Exploded View

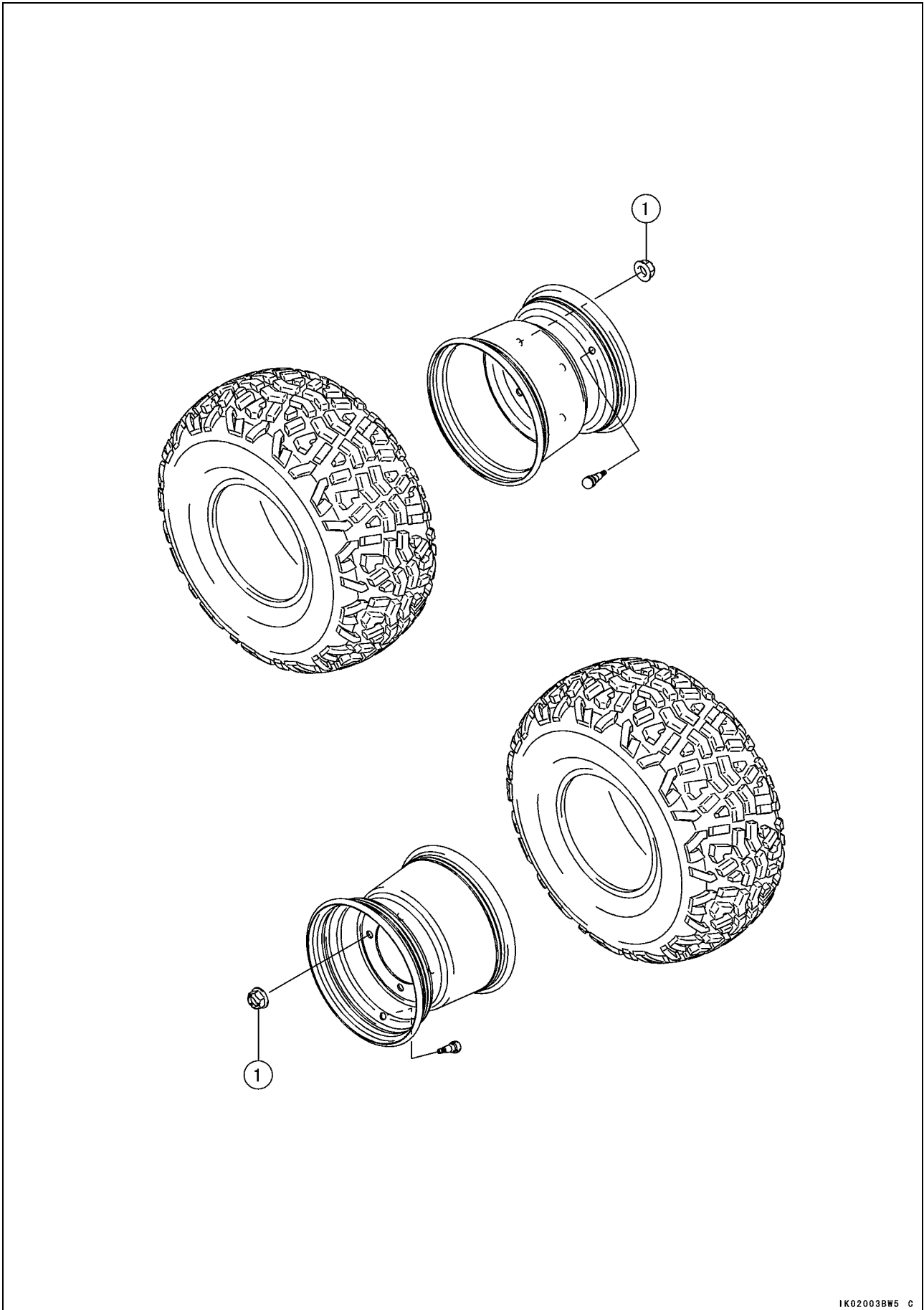

IK02003BW5 C

**Exploded View**

<b>No.</b>	<b>Fastener</b>	<b>Torque</b>			<b>Remarks</b>
		<b>N-m</b>	<b>kgf-m</b>	<b>ft-lb</b>	
1	Wheel Nuts	137	14	101	

## 11-4 WHEELS/TIRES

### Specifications

Item	Standard	Service Limit
<b>Wheel Alignment</b>		
Caster	7.5° (non-adjustable)	— — —
Camber	0.8° (non-adjustable)	— — —
Toe-in	0 ~ 20 mm (0 ~ 0.79 in.)	— — —
<b>Tires</b>		
Standard tire:		
Front and Rear	23 × 11.00-10 Dunlop KT869 Tubeless	— — — — — —
Tire air pressure (when cold):		
Front	69 kPa (0.7 kgf/cm <sup>2</sup> , 10 psi)	— — —
Rear	167 kPa (1.7 kgf/cm <sup>2</sup> , 24 psi)	— — —
Maximum tire air pressure (to seat beads, when cold)	250 kPa (2.5 kgf/cm <sup>2</sup> , 36 psi)	— — —
Tire tread depth	13.2 mm (0.52 in.)	3 mm (0.12 in.)



## Wheel Alignment

Toe-in is the amount that the front wheels are closer together in front than at the rear at the axle height. When there is toe-in, the distance **A** (Rear) is greater than **B** (Front) as shown. The purpose of toe-in is to prevent the front wheels from getting out of parallel at any time, and to prevent any slipping or scuffing action between the tires and the ground. If toe-in is incorrect, the front wheels will be dragged along the ground, scuffing and wearing the tread knobs.

Caster and camber are built-in and require no adjustment.

$A$  (Rear) -  $B$  (Front) = Amount of Toe-in

(Distance A and B are measured at hub height)

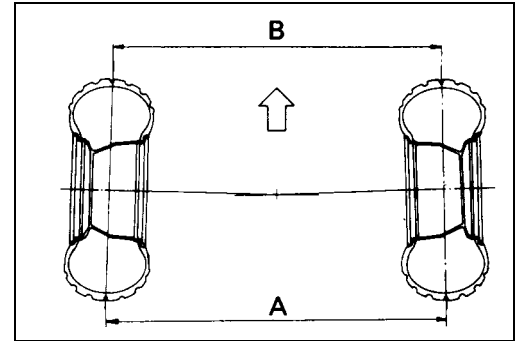

### Toe-in Adjustment

- Lift the front wheels off the ground.
- Apply a heavy coat of chalk near the center of the front tires.
- Using a needle nose scriber, make a thin mark near the center of the chalk coating while turning the wheel.
- Set the wheels so that the marks on the tires are at the front side and at the level of the axle height.
- Ground the front wheels.
- Set the steering wheel straight ahead.
- At the level of the axle height, measure the distance between the scribed lines with a measure.
- Move the vehicle rearward until the marks on the front tires are at the rear side and at the same level as the axle.
- Measure the distance between the scribed lines.
- Subtract the measurement of the front from the measurement of the rear to get the toe-in.

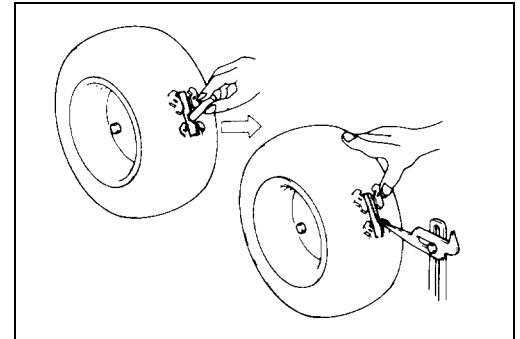

### Toe-in of Front Wheels

Standard: 0 ~ 20 mm (0 ~ 0.79 in.)

★ If the toe-in is not the specified value, perform the following procedure.

- Loosen the locknuts [A] on each tie-rod and turn the adjusting rods [B] the same number of turns and the same direction on both sides to achieve the specified toe-in.

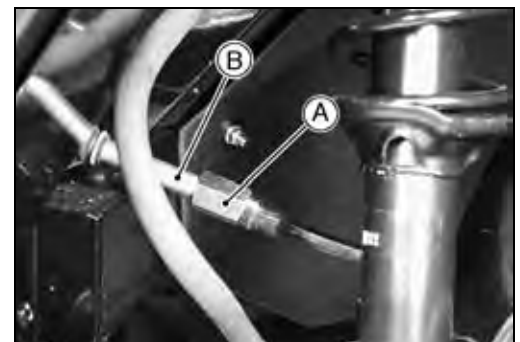

## 11-6 WHEELS/TIRES

### Wheel Alignment

---

#### NOTE

○ The toe-in will be near the specified range, if the length of the tie-rod distance between the dust boot end [A] of steering gear assembly and the locknut [B] is 43.5 mm (1.71 in.) [C] on both the left and right tie-rods.

- Check the toe-in again.
- Tighten:  
Torque - Tie-rod End Locknuts: 49 N·m (5.0 kgf·m, 36 ft·lb)
- Test drive the vehicle.

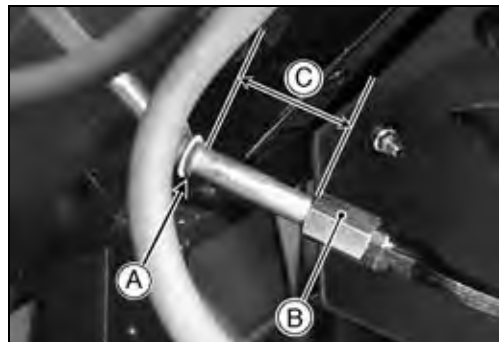

**Wheels (Rims)**

*Wheel Removal*

- Loosen the wheel nuts [A] (Do not remove).
- Lift the wheel(s) off the ground.
- Remove:
  - Wheel Nuts
  - Wheel(s)



*Wheel Installation*

- Position the wheel so that the valve stem [A] is toward the outside of the vehicle.
- Tighten:
  - Torque - Wheel Nuts: 137 N·m (14 kgf·m, 101 ft·lb)**
  - Tighten the wheel nuts in a criss-cross pattern.



*Wheel (Rim) Inspection*

- Examine both sides of the rim for dents [A].
- ★ If the rim is dented, replace it.

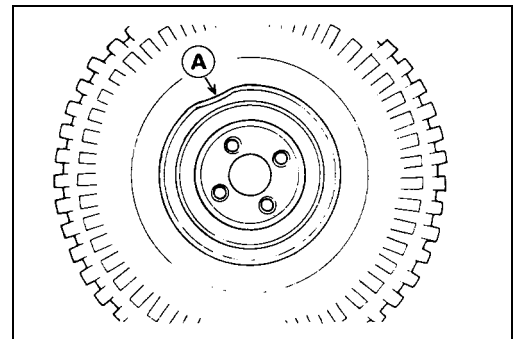

- ★ If the tire is removed, inspect the air sealing surfaces [A] of the rim for scratches or nicks. Smooth the sealing surfaces with fine emery cloth if necessary.

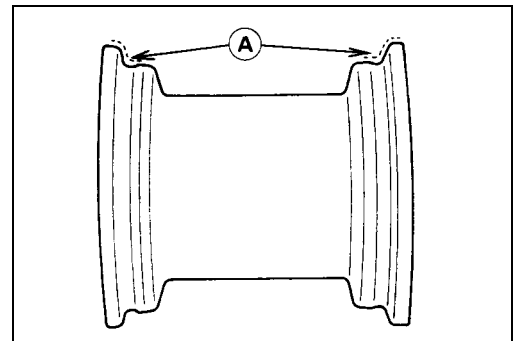

*Wheel (Rim) Replacement*

- Remove the wheel (see Wheel Removal).
- Disassemble the tire from the rim.
- Remove the valve stem and discard it.

**CAUTION**

**Replace the air valve whenever the tire is replaced.  
Do not reuse the air valve.**

- Plastic Cap [A]
- Valve Core [B]
- Stem Seal [C]
- Valve Stem [D]
- Valve Seat [E]
- Valve Opened [F]

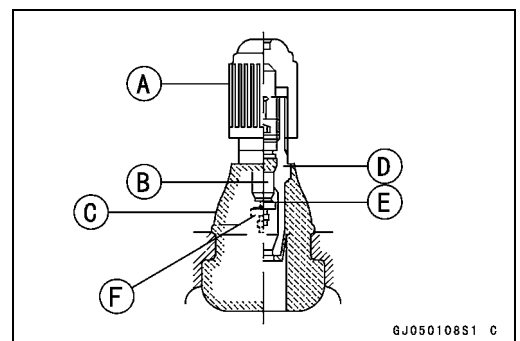

6J050108S1 C

## 11-8 WHEELS/TIRES

### Wheels (Rims)

- Install a new air valve in the new rim.
- Remove the valve cap, lubricate the stem with a soap and water solution, and pull the stem [A] through the rim from the inside out until it snaps into place.

#### CAUTION

**Do not use engine oil or petroleum distillates to lubricate the stem because they will deteriorate the rubber.**

- Mount the tire on the new rim.
- Install the wheel (see Wheel Installation).

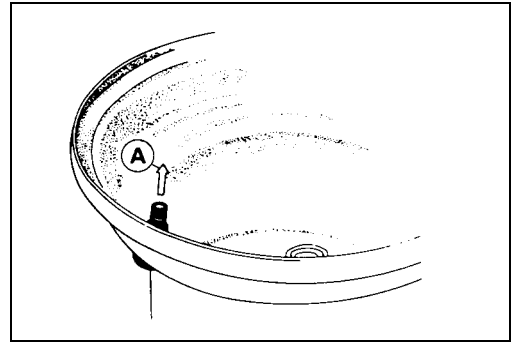

**Tires**

*Tire Removal*

- Remove:
  - Wheel (see Wheel Removal)
  - Valve Core (let out the air)
- Lubricate the tire beads and rim flanges on both sides of the wheel with a soap and water solution, or water [A]. This helps the tire beads slip off the rim flanges.

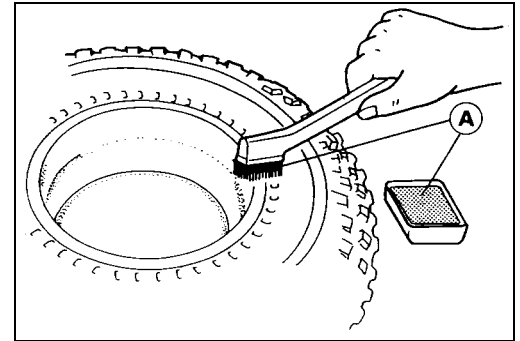

**CAUTION**

**Do not lubricate the tire beads and rim flanges with engine oil or petroleum distillates because they will deteriorate the tire.**

- Remove the tire from the rim using a suitable commercially available tire changer.

**NOTE**

○ *The tires cannot be removed with hand tools because they fit the rims tightly.*

*Tire Installation*

- Inspect the rim.
- Check the tire for wear and damage.
- Replace the air valve with a new one.

**CAUTION**

**Replace the air valve whenever the tire is replaced. Do not reuse the air valve.**

- Lubricate the tire beads and rim flanges with a soap and water solution, or water.

**⚠ WARNING**

**Do not use any lubricant other than a water and soap solution, or water to lubricate the tire beads and rim because it may cause tire separation, and a hazardous condition may result.**

- Install the tire on the rim using a suitable commercially available tire changer.
- Lubricate the tire beads again and center the tire on the rim.
- Support the wheel rim [A] on a suitable stand [B] to prevent the tire from slipping off.
- Inflate the tire until the tire beads seat on the rim.

**Maximum Tire Air Pressure (to seat beads when cold)**

Front and Rear: 250 kPa (2.5 kgf/cm<sup>2</sup>, 36 psi)

**⚠ WARNING**

**Do not inflate the tire to more than the maximum tire air pressure. Overinflation can explode the tire with possibility of injury and loss of life.**

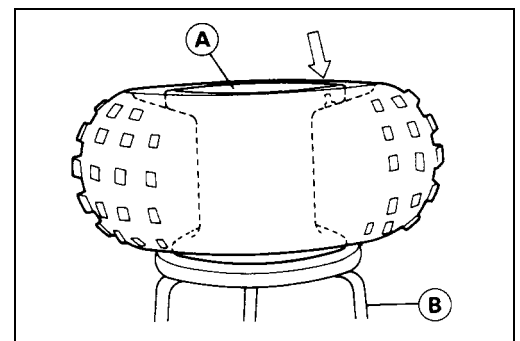

## 11-10 WHEELS/TIRES

### Tires

- Check to see that the rim lines [A] on both sides of the tire are parallel with the rim flanges [B].
- ★ If the rim lines and the rim flanges are not parallel, deflate the tire, lubricate the sealing surfaces again, and reinflate the tire.
- After the beads are properly seated, check for air leaks.
- Apply a soap and water solution around the tire bead and check for bubbles.
- Check the tire pressure using an air pressure gauge.

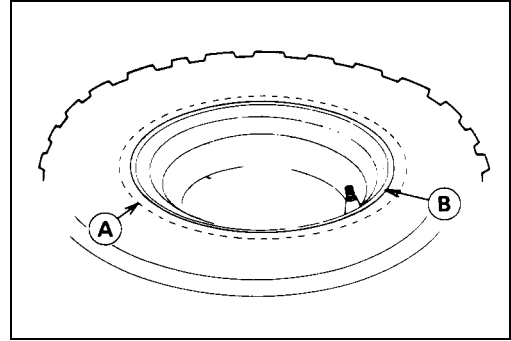

#### NOTE

○Kawasaki provides the air pressure gauge (P/N 52005-1031) as the owner's tool.

#### Tire Air Pressure (when cold)

Front: 69 kPa (0.7 kgf/cm<sup>2</sup>, 10 psi)

Rear: 167 kPa (1.7 kgf/cm<sup>2</sup>, 24 psi)

- Install the wheel (see Wheel Installation).
- Wipe off the soap and water solution, or water on the tire, and dry the tire before operation.

#### **⚠ WARNING**

**Do not operate the vehicle with the water and soap, or water still around the tire beads. They will cause tire separation, and a hazardous condition may result.**

#### *Tire Inspection*

- Refer to Tire Inspection in the Periodic Maintenance chapter.

# Final Drive

## Table of Contents

Exploded View.....	12-2	Bevel Gear Case.....	12-21
Specifications.....	12-6	Bevel Gear Case Removal.....	12-21
Special Tools.....	12-7	Bevel Gear Case Installation.....	12-21
Front Final Gear Case.....	12-8	Bevel Gear Case Disassembly....	12-21
Front Final Gear Case Oil Level		Bevel Gear Case Assembly.....	12-22
Inspection.....	12-8	Drive Bevel Gear Removal.....	12-23
Front Final Gear Case Oil		Drive Bevel Gear Installation.....	12-23
Change.....	12-8	Bevel Gear Adjustment.....	12-23
Front Final Gear Case Removal..	12-9	Bevel Gear Inspection.....	12-27
Front Final Gear Case Installation	12-9	Ball Bearing Inspection.....	12-27
Front Final Gear Case		Oil Seal Inspection.....	12-27
Disassembly.....	12-10	Damper Inspection.....	12-27
Front Final Gear Case Assembly.	12-10	Propeller Shafts.....	12-28
Differential Unit and Ring Gear		Propeller Shaft Removal.....	12-28
Disassembly.....	12-11	Propeller Shaft Installation.....	12-29
Differential Unit and Ring Gear		Propeller Shaft Inspection.....	12-30
Assembly.....	12-11	Drive Shaft and Axles.....	12-31
LSD Clutch Torque Inspection.....	12-12	Front Axle Removal.....	12-31
LSD Clutch Plate Inspection.....	12-13	Front Axle Installation.....	12-31
Pinion Gear Unit Disassembly.....	12-13	Rear Drive Shaft and Axle	
Pinion Gear Unit Assembly.....	12-13	Removal.....	12-31
Front Final Bevel Gear		Rear Drive Shaft and Axle	
Adjustment.....	12-14	Installation.....	12-32
Bevel Gear Inspection.....	12-20	Drive Shaft and Axle Inspection...	12-32
Differential Gear Inspection.....	12-20	Dust Boot Inspection.....	12-33
Tapered Roller Bearing		Front Axle Joint Boot	
Inspection.....	12-20	Replacement.....	12-33
Ball Bearing Inspection.....	12-20	Ball Bearing Inspection.....	12-37
Oil Seal Inspection.....	12-20	Grease Seal Inspection.....	12-38

# 12-2 FINAL DRIVE

## Exploded View

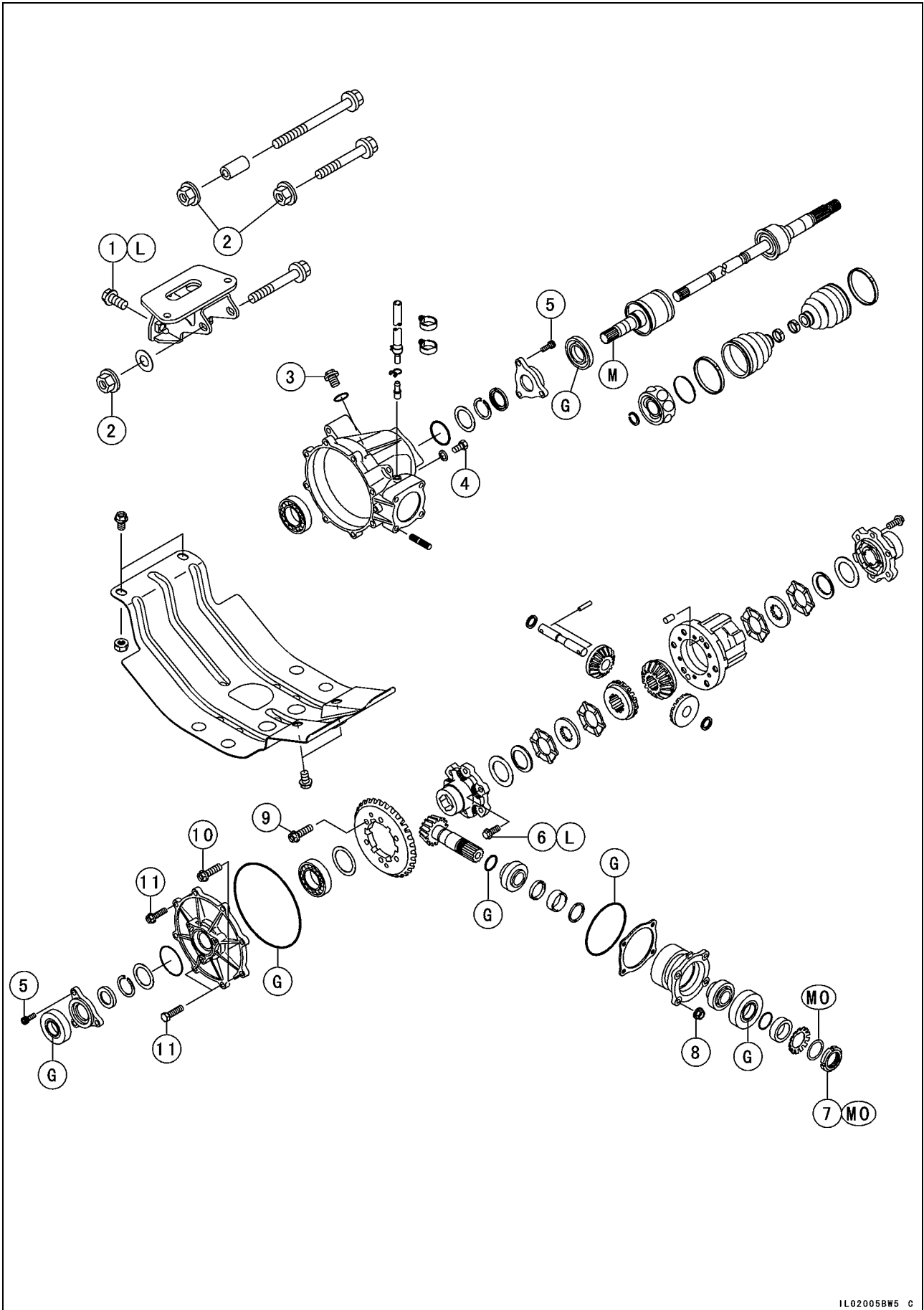

IL02005BW5 C



**Exploded View**

No.	Fastener	Torque			Remarks
		N-m	kgf-m	ft-lb	
1	Gear Case Bracket Bolts	44	4.5	33	L
2	Gear Case Mounting Nuts	44	4.5	33	
3	Oil Filler Cap	29	3.0	22	
4	Oil Drain Plug	20	2.0	14	
5	Front Axle Cap Bolts	8.8	0.90	78 in-lb	
6	Differential Case Torx Bolts	32	3.3	24	L
7	Pinion Gear Slotted Nut	120	12	87	MO
8	Pinion Gear Bearing Housing Nuts	25	2.5	18	
9	Ring Gear Bolts	49	5.0	36	
10	Ring Gear Cover Bolts (M10)	47	4.8	35	
11	Ring Gear Cover Bolts (M8)	25	2.5	18	

G: Apply grease.

L: Apply a non-permanent locking agent.

M: Apply molybdenum disulfide grease.

MO: Apply molybdenum disulfide oil solution (mixture of the engine oil and molybdenum disulfide grease in a weight ratio 10:1).

# 12-4 FINAL DRIVE

## Exploded View

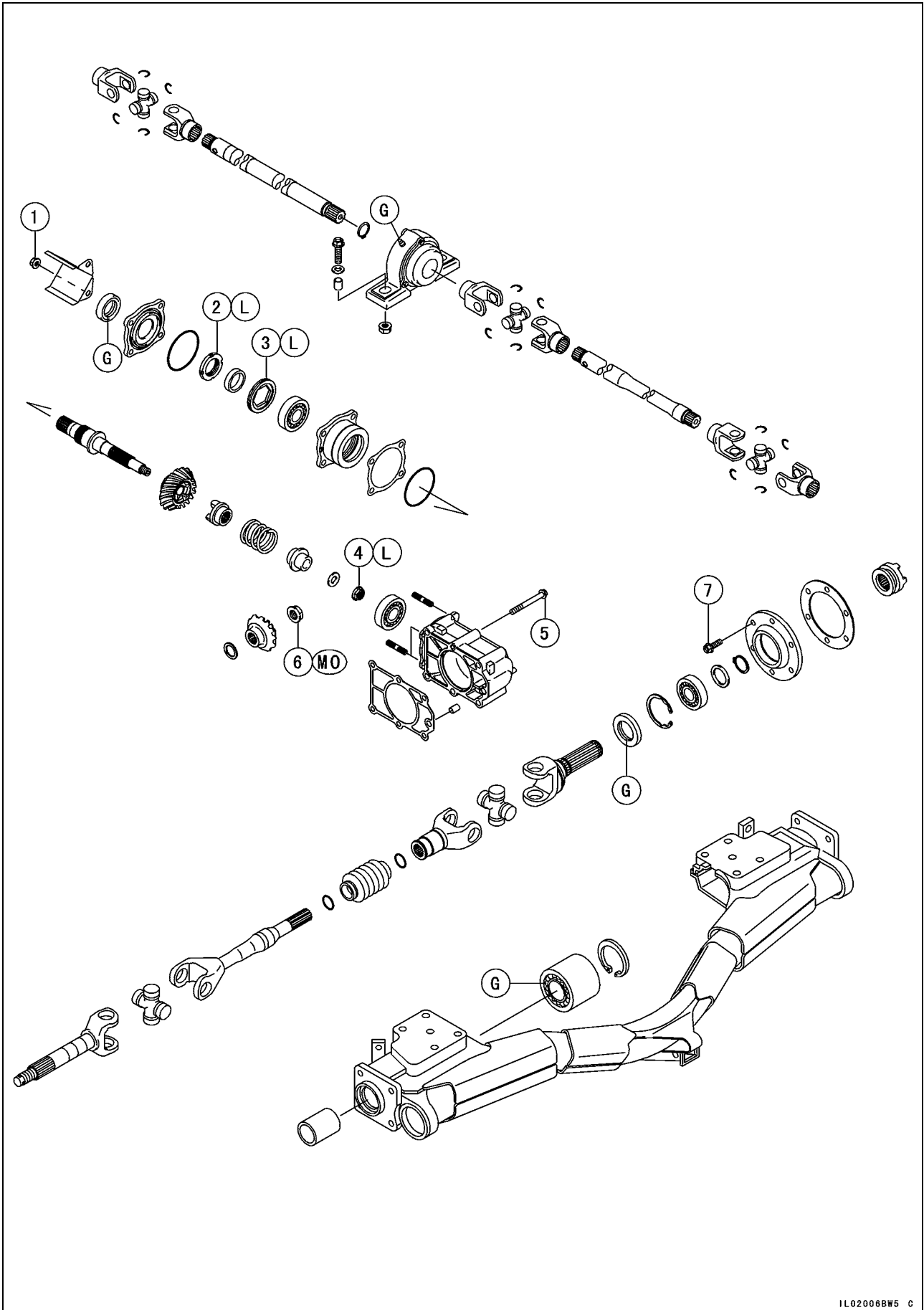

1L02006BW5 C

**Exploded View**

No.	Fastener	Torque			Remarks
		N-m	kgf-m	ft-lb	
1	Bevel Gear Case Holder Nuts	25	2.5	18	
2	Housing Locknut	120	12	87	L
3	Bearing Holder	120	12	87	L
4	Driven Gear Shaft Nut	110	11	80	L
5	Bevel Gear Case Bolts	22	2.2	16	
6	Drive Gear Nut	120	12	87	MO
7	Drive Shaft Cap Bolts	20	2.0	14	

G: Apply grease.

L: Apply a non-permanent locking agent.

MO: Apply molybdenum disulfide oil solution (mixture of the engine oil and molybdenum disulfide grease in a weight ratio 10:1).

## 12-6 FINAL DRIVE

### Specifications

Item	Standard	Service Limit
<b>Front Final Gear Case</b>		
Gear case oil:		
Type	API "GL-5 or GL-6" hypoid gear oil for LSD (Limited Slip Differential gears)	— — —
Viscosity	SAE85W-140, SAE90, or SAE140	— — —
Capacity	0.4 L (0.4 US qt)	— — —
Oil level	Filler opening level	— — —
LSD clutch torque	7.8 ~ 13 N·m (0.8 ~ 1.3 kgf·m, 69 ~ 110 in·lb)	— — —
Outside friction plate thickness	2.3 ~ 2.4 mm (0.091 ~ 0.094 in.)	2.1 mm (0.083 in.)
Inside friction plate thickness	2.7 ~ 2.8 mm (0.106 ~ 0.110 in.)	2.4 mm (0.094 in.)
Pinion gear bearing preload	1.5 ~ 3.0 N (0.15 ~ 0.30 kg)	— — —
Pinion gear bearing preload torque	0.3 ~ 0.6 N·m (0.03 ~ 0.06 kgf·m, 2.6 ~ 5.2 in·lb)	— — —
Bevel gear backlash	0.09 ~ 0.20 mm (0.0035 ~ 0.0079 in.) (at ring gear tooth)	— — —
<b>Bevel Gear Case</b>		
Bevel Gear Backlash	0.08 ~ 0.18 mm (0.0031 ~ 0.0071 in.) (at housing locknut groove)	— — —

**Special Tools**

**Bearing Puller:**  
57001-135

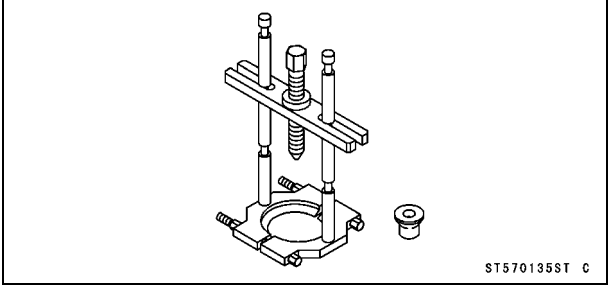

**Socket Wrench:**  
57001-1283

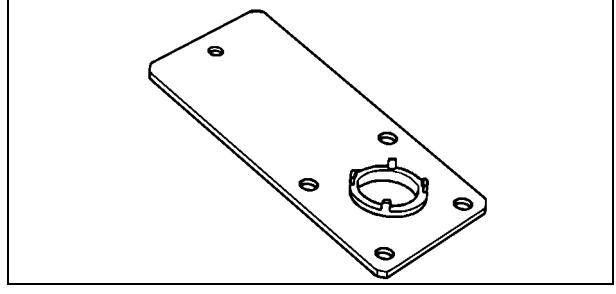

**Outside Circlip Pliers:**  
57001-144

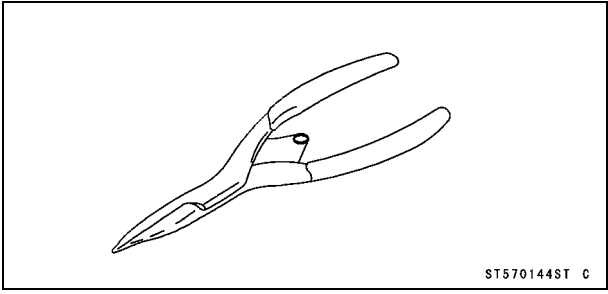

**Pinion Gear Holder:**  
57001-1285

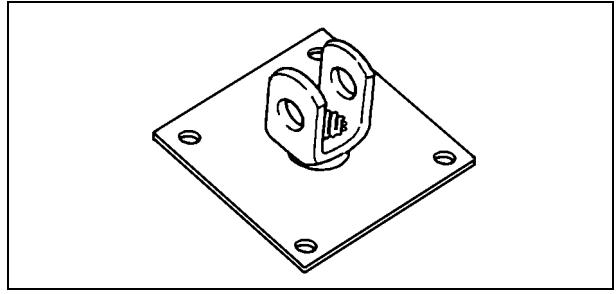

**Oil Seal & Bearing Remover:**  
57001-1058

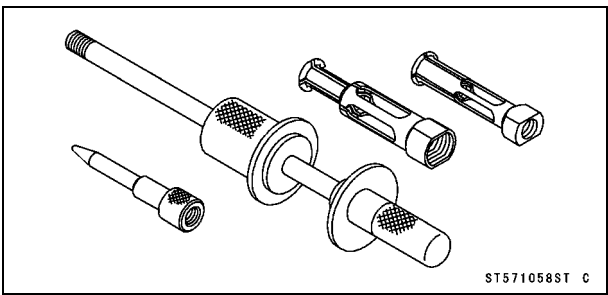

**Hexagon Wrench, Hex 40:**  
57001-1324

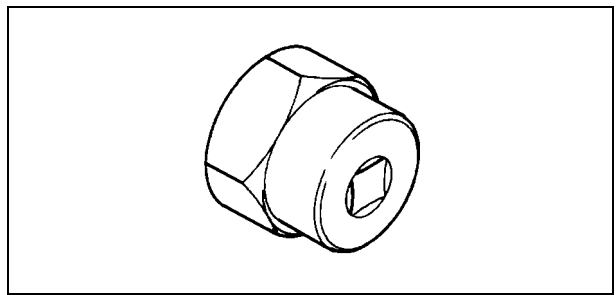

**Bearing Driver Set:**  
57001-1129

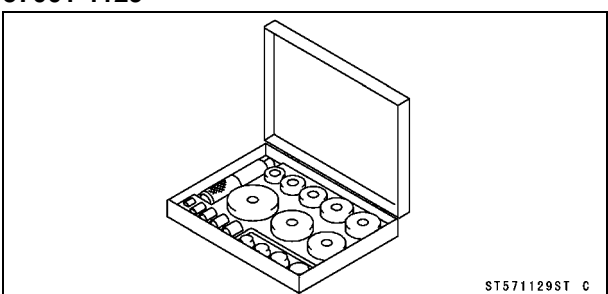

**Socket Wrench:**  
57001-1363

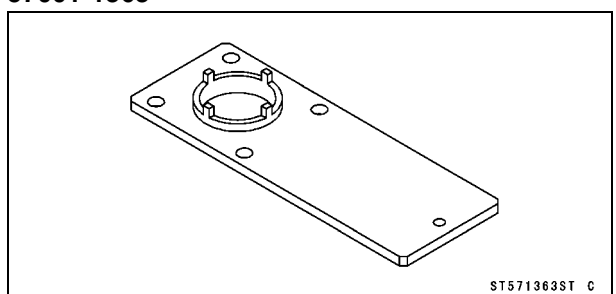

**Pinion Gear Holder:**  
57001-1281

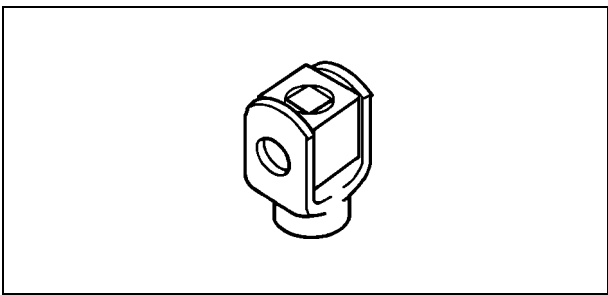

**Transmission Gear Holder:**  
57001-1364

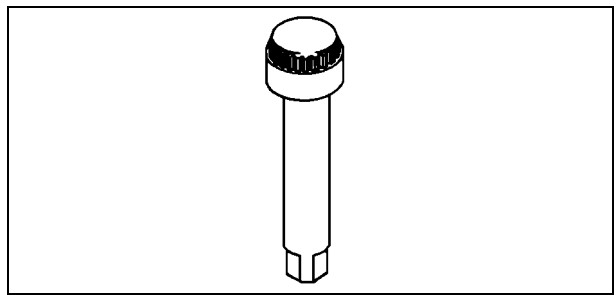

## 12-8 FINAL DRIVE

### Front Final Gear Case

#### *Front Final Gear Case Oil Level Inspection*

- Park the vehicle so that it is level, both side-to-side and front-to-rear.
- Remove:
  - Front Final Gear Case Skid Plate Bolts [A]
  - Front Final Gear Case Skid Plate [B]

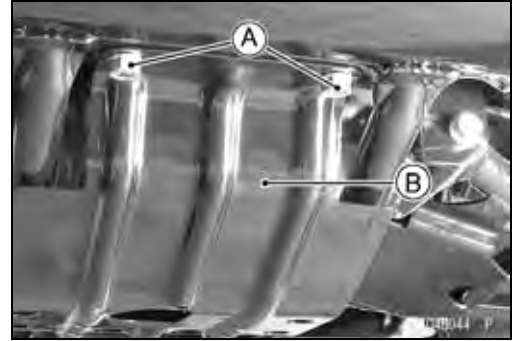

- Remove:
  - Filler Cap [A]

#### **CAUTION**

**Be careful not to allow any dirt or foreign materials to enter the gear case.**



- Check the oil level. The oil level should come to the bottom of the filler opening [A].
- ★ If it is insufficient, first check the front final gear case for oil leakage, remedy it if necessary, and add oil through the filler opening. Use the same type and brand of oil that is already in the final gear case.
- Be sure the O-ring [B] is in place, and tighten the filler cap.
  - Torque - Oil Filler Cap: 29 N·m (3.0 kgf·m, 22 ft·lb)**

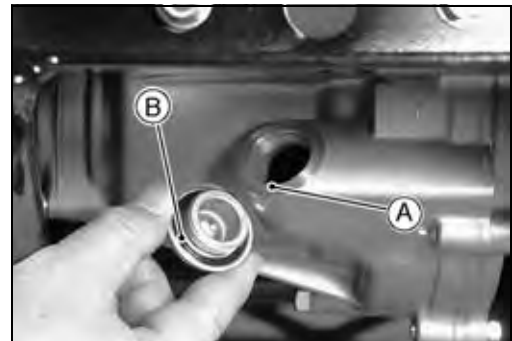

#### *Front Final Gear Case Oil Change*

- Refer to Front Final Gear Case Oil Change in the Periodic Maintenance chapter.

## Front Final Gear Case

### Front Final Gear Case Removal

- Remove:
  - Front Final Gear Case Oil (drain)
  - Radiator (see Cooling System chapter)
  - Propeller Shafts (see Propeller Shaft Removal)
  - Front Axles (see Front Axle Removal)
  - Front Final Gear Case Mounting Bolts [A] and Nuts [B]
  - Collar [C]

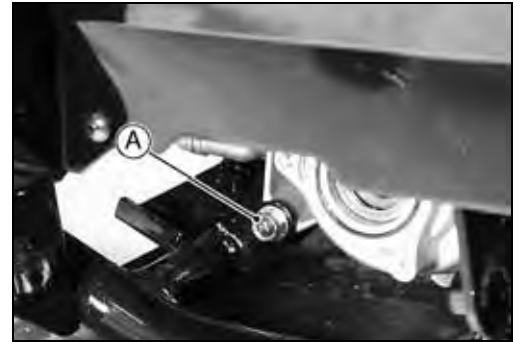
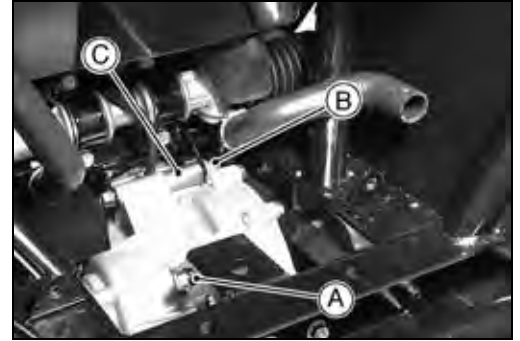

- Remove:
  - Front Final Gear Case Bracket Bolts [A]
  - Front Final Gear Case Bracket [B]

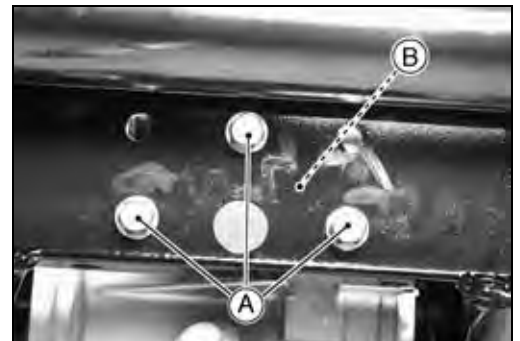

- Remove:
  - Front Final Gear Case [A] with Mounting Bolt [B]

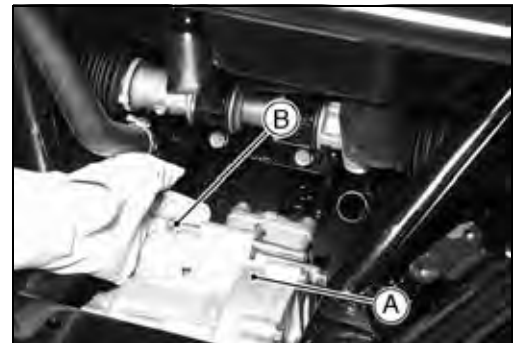

### Front Final Gear Case Installation

- Route the gear case vent hose correctly according to the General Information chapter.
- Apply a non-permanent locking agent:
  - Gear Case Bracket Bolt Threads
- Tighten:
  - Torque - Gear Case Bracket Bolts: 44 N·m (4.5 kgf·m, 33 ft·lb)**
  - Gear Case Mounting Nuts: 44 N·m (4.5 kgf·m, 33 ft·lb)**
- Adjust:
  - Front Final Gear Case Oil

## 12-10 FINAL DRIVE

### Front Final Gear Case

#### Front Final Gear Case Disassembly

- Remove:
  - Front Final Gear Case (see Front Final Gear Case Removal)
  - Bearing Housing Nuts [A]
  - Pinion Gear Unit [B]

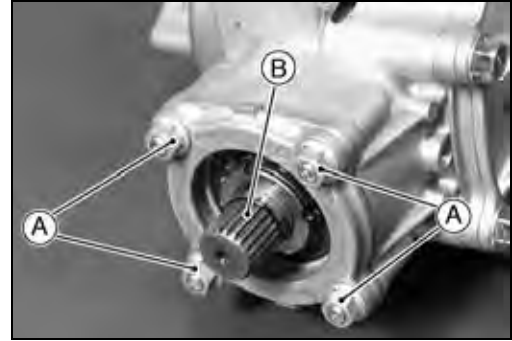

- Remove:
  - Spacers [A] (both sides)
- Remove the ring gear cover bolts, starting with the smaller bolts [B].
  - Larger Bolts [C]
  - Ring Gear Cover [D]

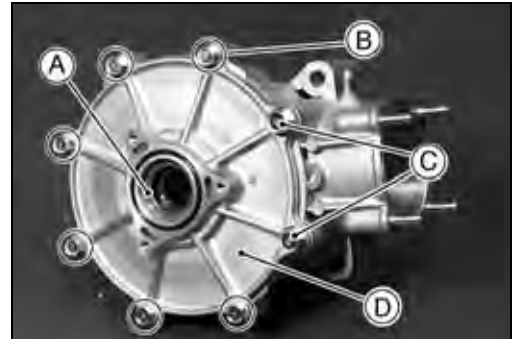

- Remove:
  - Ring Gear [A]
  - Differential Unit [B]

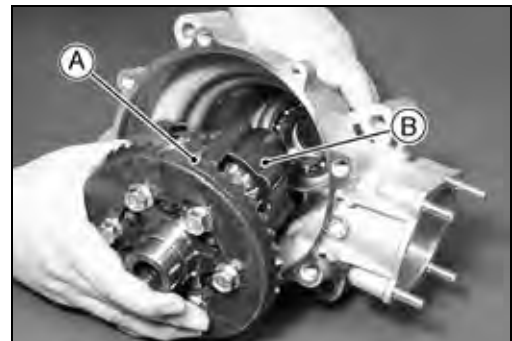

#### Front Final Gear Case Assembly

- Visually check the pinion gear and ring gear for scoring, chipping, or other damage.
- ★ Replace the bevel gears as a set if either gear is damaged since they are lapped as a set in the factory to get the best tooth contact.
- Check that the ring gear is installed on the correct side of the differential caps [A] as shown.
- Install the following parts in the order listed.
  - Differential Unit and Ring Gear
  - Ring Gear Shim [B]
  - Ring Gear Cover
  - Pinion Gear Unit

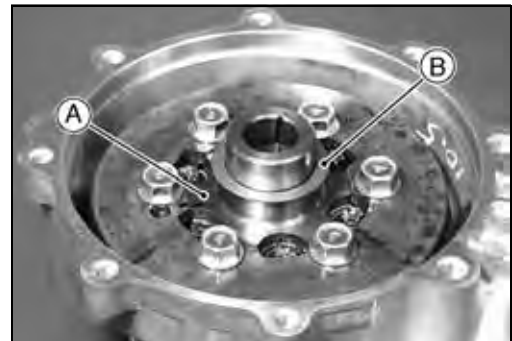



**Front Final Gear Case**

- Install the pinion gear unit with the ring gear side of the case facing down.
- Align the air vent passage [A] with the hose nipple [B].
- First tighten the 10 mm (0.39 in.) bolts, then tighten the 8 mm (0.31 in.) bolts.

**Torque - 10 mm Ring Gear Cover Bolts: 47 N·m (4.8 kgf·m, 35 ft·lb)**

**8 mm Ring Gear Cover Bolts: 25 N·m (2.5 kgf·m, 18 ft·lb)**

**Pinion Gear Bearing Housing Nuts: 25 N·m (2.5 kgf·m, 18 ft·lb)**

- Adjust:
  - Front Final Gear Backlash (see Front Final Bevel Gear Adjustment)
  - Front Final Gear Tooth-Contact (see Front Final Bevel Gear Adjustment)

*Differential Unit and Ring Gear Disassembly*

- Remove the differential unit and ring gear (see Front Final Gear Case Disassembly).

<b>CAUTION</b>
<b>Do not interchange the right and left side parts in the differential unit.</b>

- Remove the following parts to disassemble the differential unit.
  - Ring Gear Bolts [A]
  - Ring Gear [B]
  - Differential Caps [C]
  - Mark here to assemble later [D]
- The clutch plates, springs, spring shims, and side gears come out.

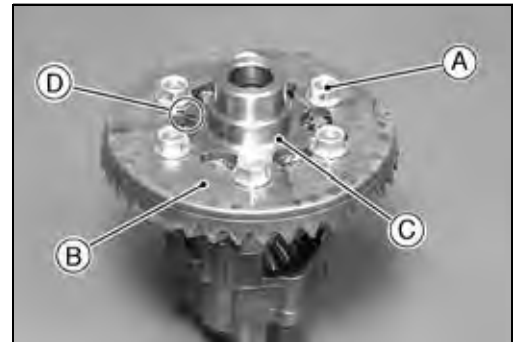
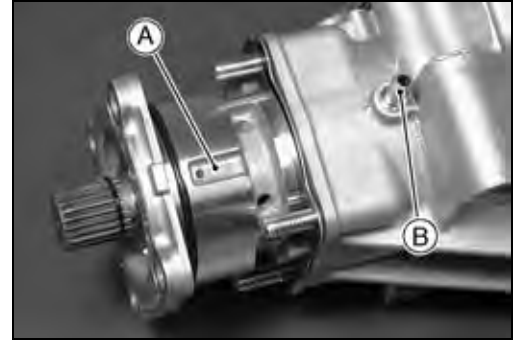

*Differential Unit and Ring Gear Assembly*

<b>CAUTION</b>
<b>Be sure to install the right and left side parts of the unit in the original position.</b>

- Inspect the clutch plates (see Clutch Plate Inspection) and the other differential unit parts. Replace any damaged parts.
- Measure and record the thickness of the original clutch spring shim(s).
- Apply specified gear oil to the differential unit parts.
- Note direction and position of the friction plate and the clutch spring.
  - Clutch Spring Shim(s) [A]
  - Clutch Spring [B]
  - Outside Friction Plate [C]
  - Steel Plate [D]
  - Inside Friction Plate [E]

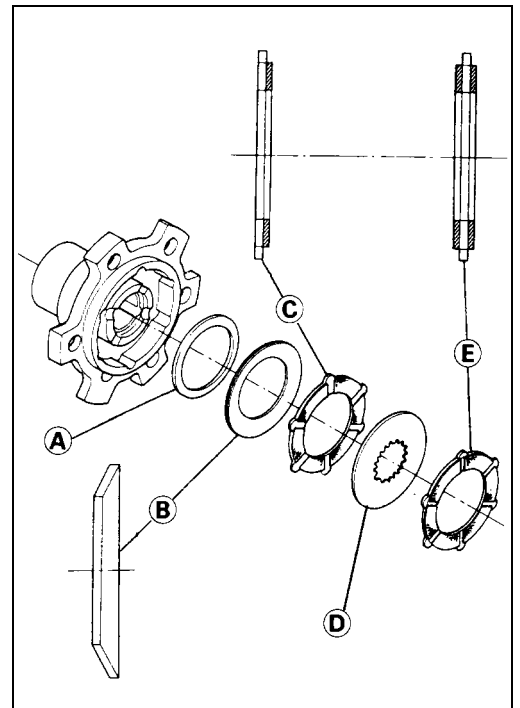

## 12-12 FINAL DRIVE

### Front Final Gear Case

- Be sure to assemble the differential unit and inspect the clutch torque (see LSD Clutch Torque Inspection).  
Tapped Holes [A] for Ring Gear  
Mark [B] for assembly
- Install the front axles [C] to center the steel plates.
- Apply a non-permanent locking agent:  
Differential Case Torx Bolts [D]
- Tighten:  
**Torque - Differential Case Torx Bolts: 32 N·m (3.3 kgf·m, 24 ft·lb)**  
**Ring Gear Bolts: 49 N·m (5.0 kgf·m, 36 ft·lb)**

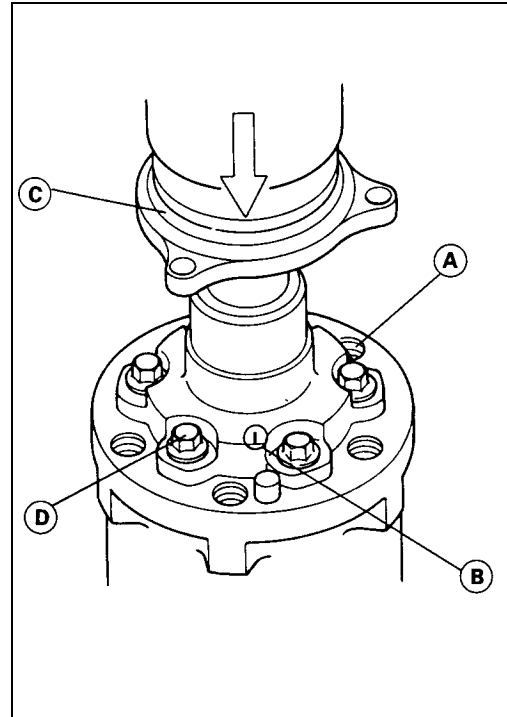

#### LSD Clutch Torque Inspection

- After assembling the differential unit and ring gear, check the LSD clutch torque.
- Remove the ring gear from the differential unit [A].
- Insert both front axles [B] in the unit.
- Hold one of the front axles with a vise.
- Install the hub nut on the other axle.
- Measure the clutch torque using a torque wrench [C]. Turn the wrench evenly.
- The clutch torque is the mean torque reading during about a quarter turn of the wrench.

#### LSD Clutch Torque

**Standard: 7.8 ~ 13 N·m (0.8 ~ 1.3 kgf·m, 69 ~ 110 in·lb)**

- ★ If the clutch torque is out of the specified range, disassemble the differential unit (see Differential Unit and Ring Gear Disassembly) and replace either of the clutch spring shim(s).
- Also, check the clutch plates and replace them as necessary (see Clutch Plate Inspection).
- To increase clutch torque, increase the thickness of the shim(s).
- Change the thickness a little at a time.
- Recheck the clutch torque and readjust as necessary.

Thickness	Part Number
0.8 mm (0.031 in.)	92180-1121
1.0 mm (0.039 in.)	92180-1122
1.2 mm (0.047 in.)	92180-1123
1.4 mm (0.055 in.)	92180-1124
1.6 mm (0.063 in.)	92180-1125

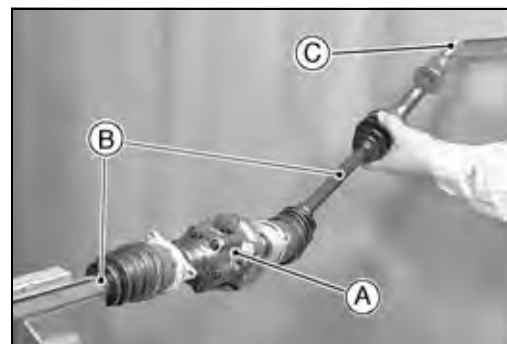

## Front Final Gear Case

### LSD Clutch Plate Inspection

- Visually inspect the friction plates and steel plates to see if they show any signs of seizure, overheating, or uneven wear.
- ★ If any plates show signs of damage, or if the friction plates have worn past the service limit, replace the friction plates and steel plates as a set.
  - Outside Friction Plate [A]
  - Inside Friction Plate [B]

### Outside Friction Plate Thickness

- **Standard:** 2.3 ~ 2.4 mm (0.091 ~ 0.094 in.)
- **Service Limit:** 2.1 mm (0.083 in.)

### Inside Friction Plate Thickness

- **Standard:** 2.7 ~ 2.8 mm (0.106 ~ 0.110 in.)
- **Service Limit:** 2.4 mm (0.094 in.)

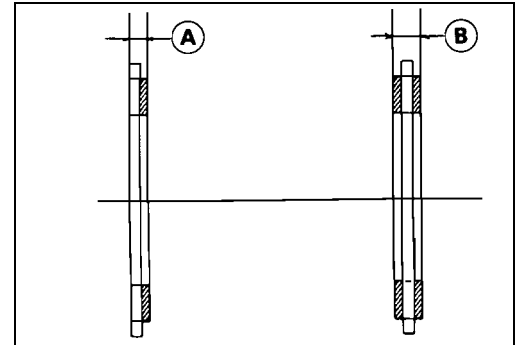

### Pinion Gear Unit Disassembly

- Remove the pinion gear unit (see Front Final Gear Case Disassembly).
- Pry open the toothed washer tab [A] on the pinion gear slotted nut [B].



- Unscrew the pinion gear slotted nut.
  - **Special Tools - Pinion Gear Holder: 57001-1281 [A]**
  - **Socket Wrench: 57001-1283 [B]**
- Remove the slotted nut, flat washer, and toothed washer.
- Pull the pinion gear out of the bearing housing.
- Remove the tapered roller bearing inner race as necessary.
  - **Special Tool - Bearing Puller: 57001-135**

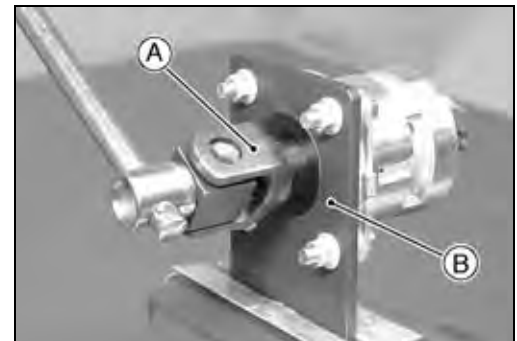

### Pinion Gear Unit Assembly

- The pinion gear and ring gear are lapped as a set in the factory to get the best tooth contact. They must be replaced as a set.
- Visually inspect the tapered roller bearings for abrasion, color change, or other damage.
- ★ If there is any doubt as to the condition of a bearing, replace the bearing housing and the bearings as a set.
- Be sure to check and adjust the pinion gear bearing preload and the bevel gear backlash and tooth contact, when any of the backlash-related parts are replaced (see Front Final Bevel Gear Adjustment).
- When the pinion gear slotted nut is loosened, even if the purpose is not to replace the parts, check and adjust the bearing preload.

## 12-14 FINAL DRIVE

### Front Final Gear Case

- Fit the toothed washer claw [A] into the shaft.
- Apply molybdenum disulfide oil to the threads and seating surface of the pinion gear slotted nut, and tighten it.

**Torque - Pinion Gear Slotted Nut: 120 N·m (12 kgf·m, 87 ft·lb)**

- ★ If none of the toothed washer tabs [B] align, tighten the nut further just enough to align one of the tabs with a slot [C] in the nut.
- Bend the tab over the nut.

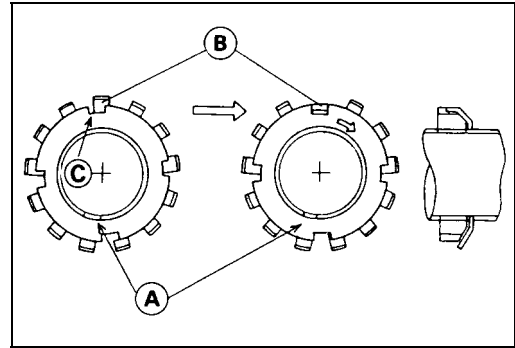

#### Front Final Bevel Gear Adjustment

In order to prevent one gear from moving away from the other gear under load, the tapered roller bearings must be properly **preloaded**. Also the **backlash** (distance one gear will move back and forth without moving the other gear) and **tooth contact pattern** of the bevel gears must be correct to prevent the gears from making noise and being damaged.

Above three adjustments are of critical importance and must be carried out following the correct sequence and method.

- When any one of the backlash-related parts are replaced or the pinion gear nut is loosened; even if the purpose is not to replace the parts, check and adjust the bearing preload, the bevel gear backlash, and tooth contact by replacing shims.
- The amount of backlash is influenced by the ring gear position more than by the pinion gear position.
- Tooth contact location is influenced by pinion gear position more than by ring gear position.

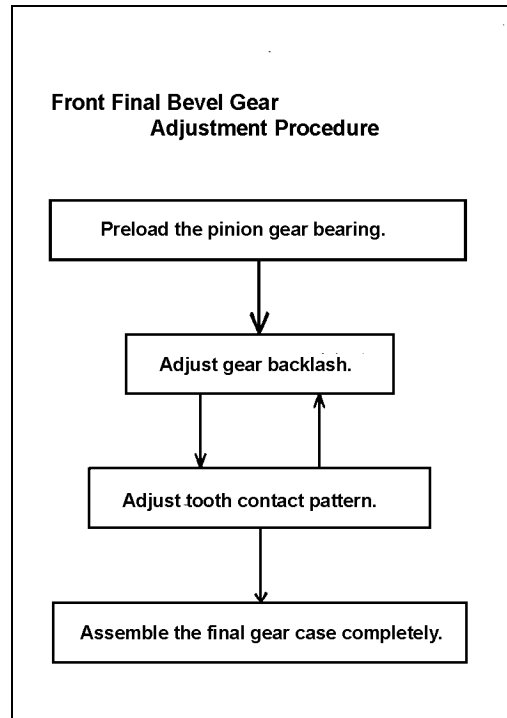

## Front Final Gear Case

### Bearing Preload Adjustment:

- Check and adjust the bearing preload in the following cases.
- When any of the parts listed below are replaced with new ones.
  - Pinion Gear
  - Collar
  - Shim
  - Tapered Roller Bearings
  - Pinion Gear Bearing Housing [A]
  - Oil Seal Collar
- When the pinion gear slotted nut [B] is loosened; even if the nut is not removed.
- Install the pinion gear bearing housing and tighten the pinion gear slotted nut to the specified torque (see Pinion Gear Unit Disassembly/Assembly).
- Do not install the oil seal and O-rings, and do not lock the washer until the correct bearing preload is obtained.

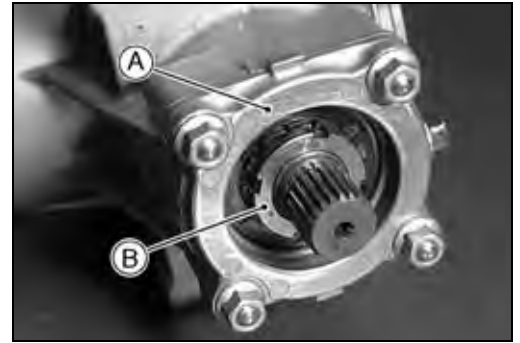

### CAUTION

**To start with, choose a shim or collar so that the bearings are just SNUG with NO play but also with NO preload. An over-preload on the bearings could damage the bearings.**

- Apply specified gear oil to the bearings, and turn the gears more than 5 turns to allow the bearings to seat.
- Measure the bearing preload. Bearing preload is the force or torque which is needed to start the gear shaft turning.

### NOTE

- Preload can be measured either with a spring scale or a beam-type torque wrench. When measured with a spring scale, the preload is designated by force (N, kg), and when measured with a torque wrench, it is designated by torque (N·m, kgf·m, in·lb).

# 12-16 FINAL DRIVE

## Front Final Gear Case

### Front Final Gear Case (Backlash-Related Parts)

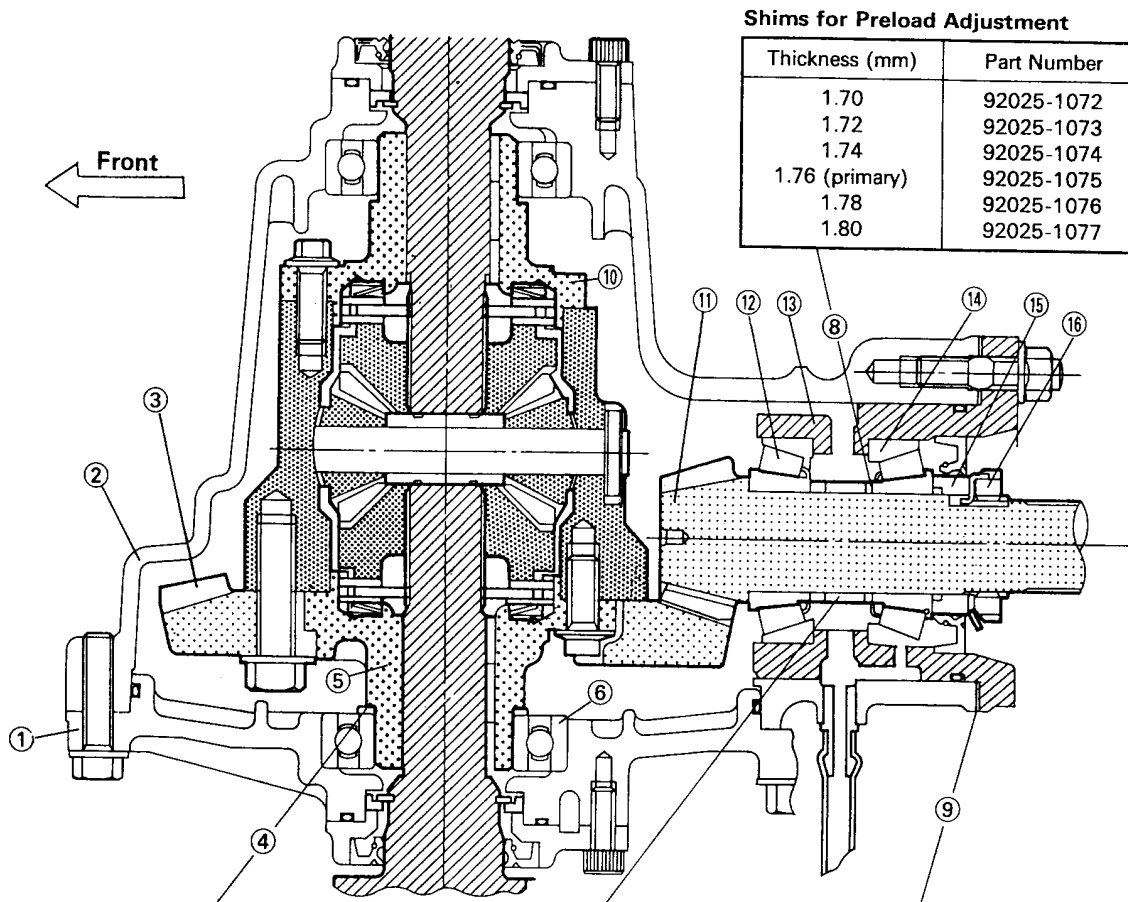

#### Shims for Preload Adjustment

Thickness (mm)	Part Number
1.70	92025-1072
1.72	92025-1073
1.74	92025-1074
1.76 (primary)	92025-1075
1.78	92025-1076
1.80	92025-1077

#### Ring Gear Shims for Backlash Adjustment

Thickness (mm)	Part Number
0.1	92025-1850
0.15	92025-1851
0.5	92025-1856
0.8	92025-1857
1.0 (primary)	92025-1849

#### Pinion Gear Shims for Tooth Contact Adjustment

Thickness (mm)	Part Number
0.1	92025-1919
0.15	92025-1920
0.5	92025-1921
0.8	92025-1922
1.0 (primary)	92025-1923
1.2	92025-1924

#### Collar for Preload Adjustment

Thickness (mm)	Part Number
10.2	92027-1401
10.3	92027-1402
10.4	92027-1403
10.5	92027-1404
10.6	92027-1405
10.7 (primary)	92027-1406
10.8	92027-1407
10.9	92027-1408
11.0	92027-1409
11.1	92027-1410
11.2	92027-1411

1. Ring Gear Cover
2. Front Final Gear Case
3. Ring Gear
4. Ring Gear Shims for Backlash Adjustment
5. Left Differential Cap
6. Ball Bearing
7. Collar for Preload Adjustment (affects preload only)
8. Shims for Preload Adjustment (affects preload only)
9. Pinion Gear Shims for Tooth Contact Adjustment
10. Right Differential Cap
11. Pinion Gear
12. Tapered Roller Bearing
13. Pinion Gear Bearing Housing
14. Tapered Roller Bearing (affects preload only)
15. Oil Seal Collar (affects preload only)
16. Pinion Gear Slotted Nut (affects preload only)

## Front Final Gear Case

- ★ If the preload is out of the specified range, replace the collar and/or shim(s).
- To increase preload, decrease the size of the shim(s) or collar. To decrease preload, increase the size of the shim(s) or collar.
- Change the thickness a little at a time.
- Recheck the bearing preload, and readjust as necessary.
- Measure the bearing preload using a spring scale.

### Using Spring Scale

**Pinion Gear Bearing Preload:** 1.5 ~ 3.0 N (0.15 ~ 0.30 kg)

- Hook the spring scale [A] on the handle at a point 200 mm (7.87 in.) [B] apart from the center of the gear shaft. Hold the bearing housing in a vise so that the gear shaft is vertical.
- Apply force to the handle horizontally and at a right angle to it.

**Special Tool - Pinion Gear Holder: 57001-1281 [C]**

- Measure the bearing preload using a torque wrench [A].

### Using Torque Wrench

**Pinion Gear Bearing Preload Torque:**

0.3 ~ 0.6 N·m (0.03 ~ 0.06 kgf·m, 2.6 ~ 5.2 in·lb)

**Special Tool - Pinion Gear Holder: 57001-1281 [B]**

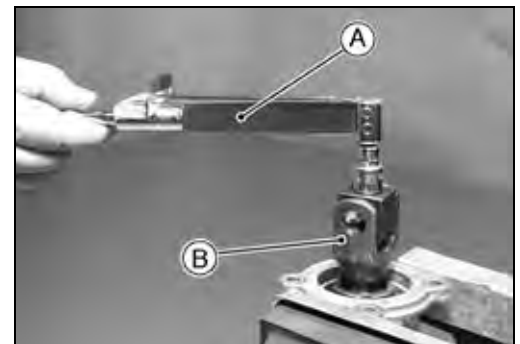
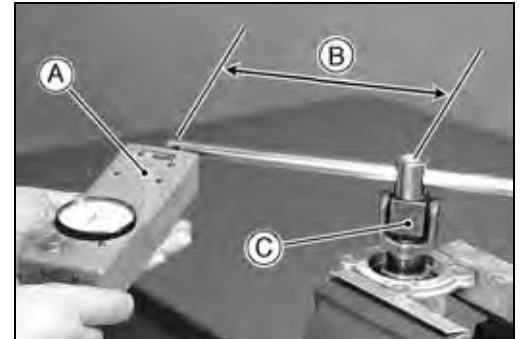

## Backlash Adjustment

- Check and adjust the gear backlash when any of the backlash-related parts are replaced with new ones.
- Clean any dirt and oil off the bevel gear teeth.
- Assemble the front final gear case (see Front Final Gear Case Assembly). Do not install the O-rings during adjustment.
- Check the backlash during tightening of the ring gear cover bolts and stop tightening them immediately if the backlash disappears. Then, change the ring gear shim to a thinner one.
- Set up a dial gauge against a ring gear tooth to check gear backlash shown.
- To measure the backlash, move the left front axle (ring gear side) back and forth while holding the pinion gear steady. The difference between the highest and the lowest gauge reading is the amount of backlash.
- ★ If the backlash is not within the limit, replace the ring gear shims. To increase backlash, decrease the thickness of the shim(s). To decrease backlash, increase the thickness of the shim(s).
- Change the thickness a little at a time.
- Recheck the backlash, and readjust as necessary.

## 12-18 FINAL DRIVE

### Front Final Gear Case

- Move the front axle back and forth [A].

**Special Tool - Pinion Gear Holder: 57001-1285 [B]**

Dial Gauge [C]

#### Bevel Gear Backlash

**Standard: 0.09 ~ 0.20 mm (0.035 ~ 0.0079 in.) (at ring gear tooth)**

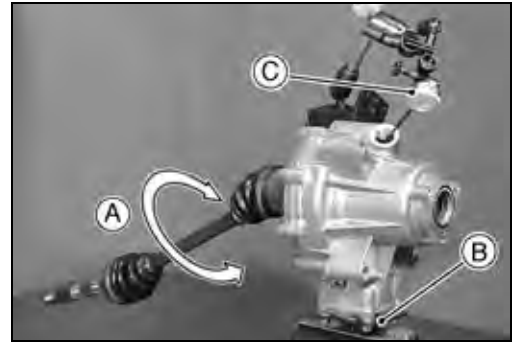

#### Tooth Contact Adjustment

- Clean any dirt and oil off the bevel gear teeth.
- Apply checking compound to 4 or 5 teeth on the pinion gear.

#### NOTE

- Apply checking compound to the teeth in a thin, even coat with a fairly stiff paint brush. If painted too thickly, the exact tooth pattern may not appear.
- The checking compound must be smooth and firm, with the consistency of tooth paste.
- Special compounds are available from automotive supply stores for the purpose of checking differential gear tooth patterns and contact. Use one of these for checking the bevel gears.

- Assemble the front final gear case (see Front Final Gear Case Assembly). Do not install the O-rings during adjustment.
- Turn the pinion gear shaft for one revolution in the drive and reverse (coast) direction, while creating a drag on the ring gear.
- Use the pinion gear holder [A] and the left front axle.

**Special Tool - Pinion Gear Holder: 57001-1281**

- Remove the ring gear and pinion gear unit to check the drive pattern and coast pattern of the bevel gear teeth.
- The tooth contact patterns of both (drive and coast) sides should be centrally located between the top and bottom of the tooth. The drive pattern can be a little closer to the toe and the coast pattern can be a somewhat longer and closer to the toe.
- ★ If the tooth contact pattern is incorrect, replace the pinion gear shim(s), following the examples shown.
- Then erase the tooth contact patterns and check them again. Also check the backlash every time the shim(s) are replaced. Repeat the shim change procedure as necessary.

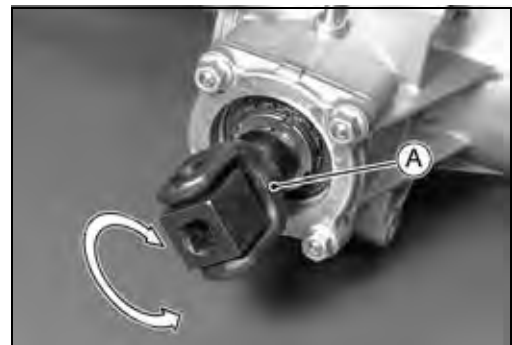

#### NOTE

- If the backlash is out of the standard range after changing the pinion gear shim(s), change the ring gear shim(s) to correct the backlash before checking the tooth contact pattern.



Front Final Gear Case

Correct Tooth Contact Pattern: No adjustment is required.

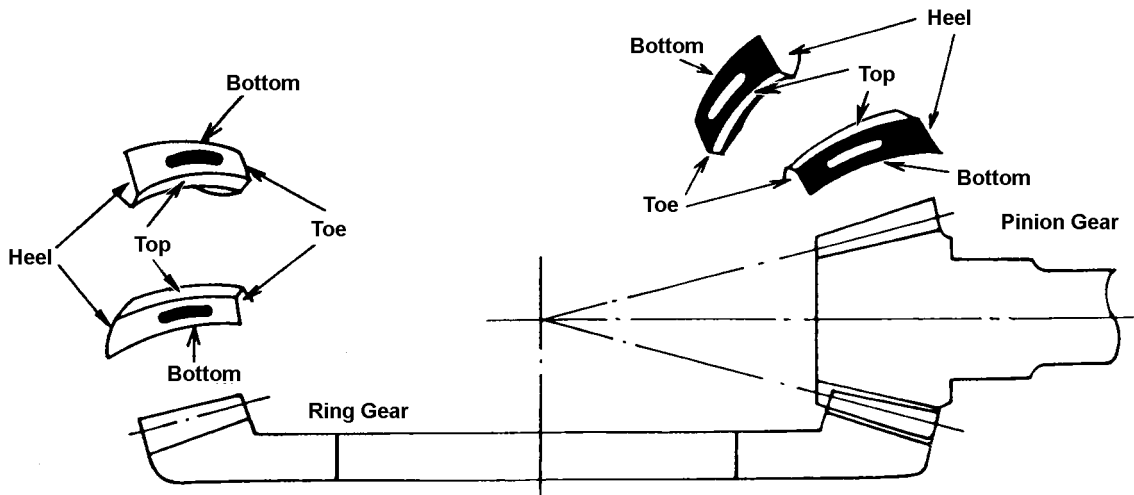

Incorrect Tooth Contact Patterns

Example 1 : Decrease the thickness of the pinion gear shim(s) by 0.05 mm (0.002 in.) to correct the pattern shown below. Repeat in 0.05 mm (0.002 in.) steps if necessary.

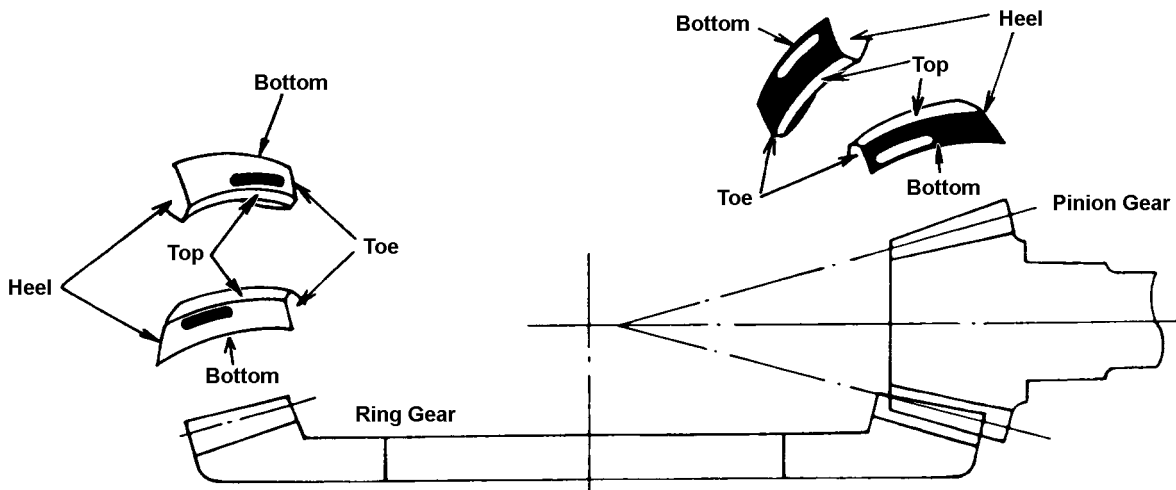

Example 2 : Increase the thickness of the pinion gear shim(s) by 0.05 mm (0.002 in.) to correct the pattern shown below. Repeat in 0.05 mm (0.002 in.) steps if necessary.

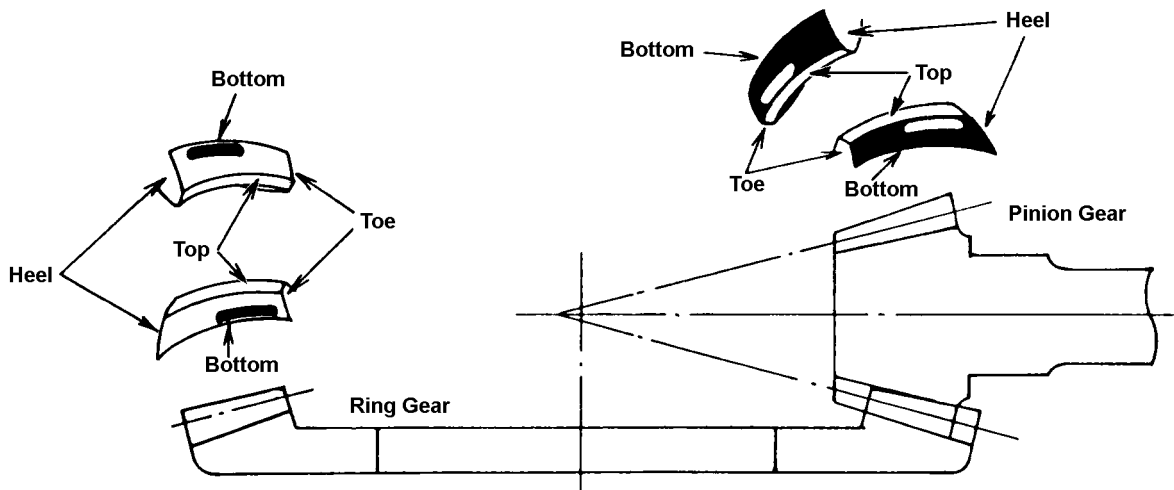

## 12-20 FINAL DRIVE

### Front Final Gear Case

#### *Bevel Gear Inspection*

- Visually check the bevel gears [A] for scoring, chipping, or other damage.
- ★ Replace the bevel gears as a set if either gear is damaged.

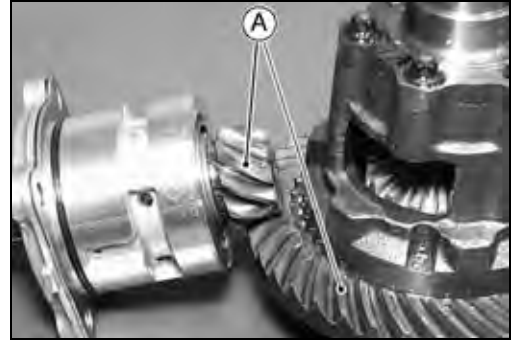

#### *Differential Gear Inspection*

- Visually check the differential gears [A] for scoring, chipping, or other damage.
- Also, inspect the differential pinion gear shaft [B] and gear housing [C] where the differential gears rub.
- ★ If they are scored, discolored, or otherwise damaged, replace them as a set.

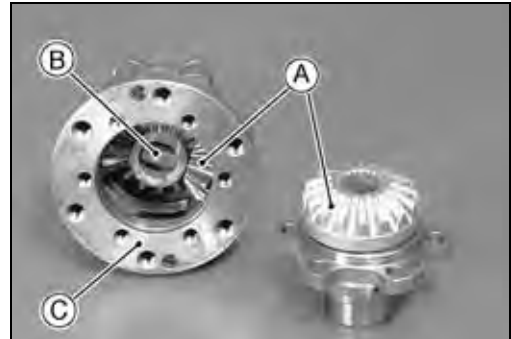

#### *Tapered Roller Bearing Inspection*

- Visually inspect the bearings [A] for abrasion, color change, or other damage.
- ★ If there is any doubt as to the condition of a bearing, replace it.

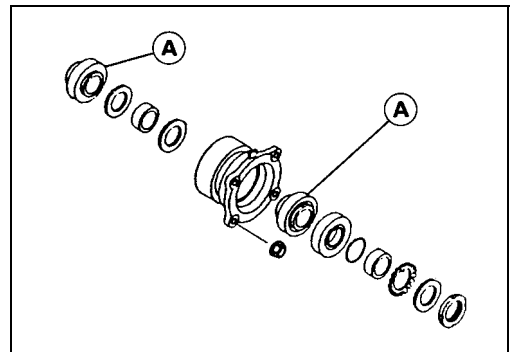

#### *Ball Bearing Inspection*

- Since the ball bearings are made to extremely close tolerances, the wear must be judged by feel rather than measurement. Clean each bearing in a high flash-point solvent, dry it (do not spin the bearing while it is dry), and oil it with engine oil.
- Spin the bearing by hand [A] to check its condition.
- ★ If the bearing [B] is noisy, does not spin smoothly, or has any rough spots, replace it.

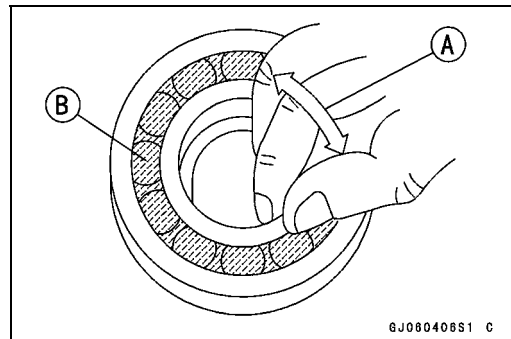

#### *Oil Seal Inspection*

- Visually inspect the oil seal.
- ★ Replace it if the lips are misshapen, discolored (indicating that the rubber has deteriorated), hardened, or been otherwise damaged.

## Bevel Gear Case

### Bevel Gear Case Removal

- Remove:
  - Transmission Oil (drain)
  - Cargo Bed (see Frame chapter)
  - Propeller Shafts (see Propeller Shaft Removal)
  - Bevel Gear Case Bolts [A]
  - Bevel Gear Case [B]

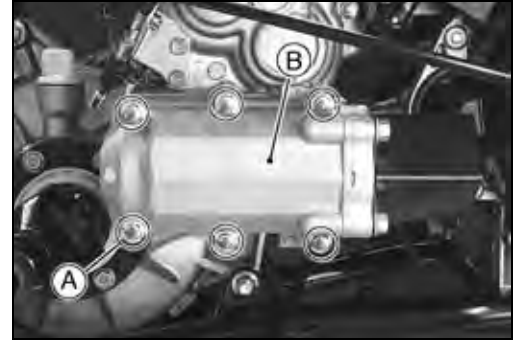

### Bevel Gear Case Installation

- Check and adjust the bevel gear backlash and tooth contact when any of the backlash-related parts are replaced (see Bevel Gear Adjustment).
- Check to see that the bevel gear case knock pin [A] is in place.
- Tighten:
  - Torque - Bevel Gear Case Bolts: 22 N-m (2.2 kgf-m, 16 ft-lb)**



### Bevel Gear Case Disassembly

- Remove:
  - Holder Nuts [A]
  - Cover [B]
  - Holder [C]

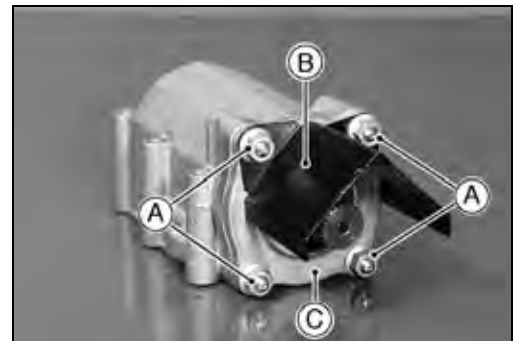

- ★ If the driven gear assembly is to be disassembled, loosen the housing locknut [A].

**Special Tools - Pinion Gear Holder: 57001-1281 [C]**  
**Socket Wrench: 57001-1363 [B]**

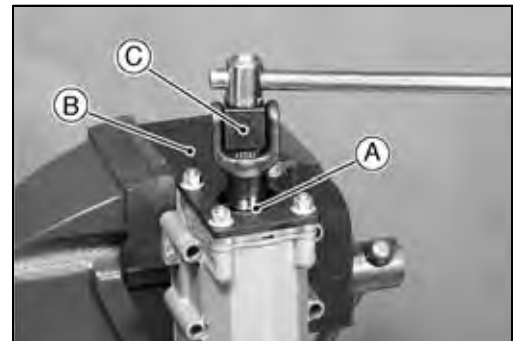

- Remove:
  - Driven Gear Assembly [A]
  - Driven Gear Shim(s) [B]



## 12-22 FINAL DRIVE

### Bevel Gear Case

- Remove:

- Housing Locknut
  - Bearing Housing [A]

- Special Tools - Pinion Gear Holder: 57001-1281 [C]**

- Socket Wrench: 57001-1363 [B]**

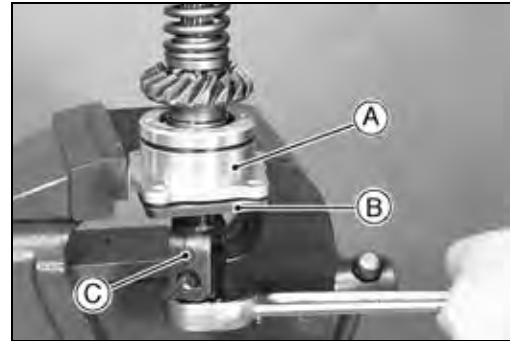

- Remove:

- Driven Gear Shaft Nut [A]

- Special Tool - Pinion Gear Holder: 57001-1281 [B]**

- Pressing the spring seat [C], remove the driven gear shaft nut.

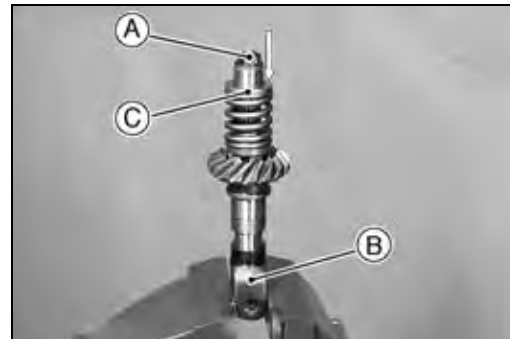

- Remove:

- Bearing Holder [A]

- Special Tool - Hexagon Wrench, Hex 40: 57001-1324 [B]**

- Remove:

- Ball Bearings

- Special Tools - Oil Seal & Bearing Remover: 57001-1058**

- Bearing Driver Set: 57001-1129**

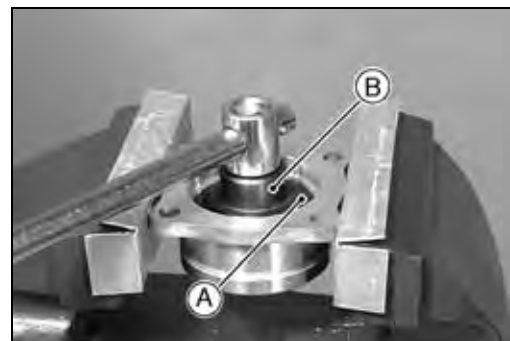

#### *Bevel Gear Case Assembly*

- Install the housing locknut [A] so that the chamfered side [B] faces to the bearing.

- Apply a non-permanent locking agent:

- Driven Gear Shaft Nut

- Bearing Holder

- Housing Locknut

- Tighten:

- Torque - Driven Gear Shaft Nut: 110 N·m (11 kgf·m, 80 ft·lb)**

- Bearing Holder: 120 N·m (12 kgf·m, 87 ft·lb)**

- Housing Locknut: 120 N·m (12 kgf·m, 87 ft·lb)**

- Bevel Gear Case Holder Nuts: 25 N·m (2.5 kgf·m, 18 ft·lb)**

- Grease:

- Holder Oil Seal Lips

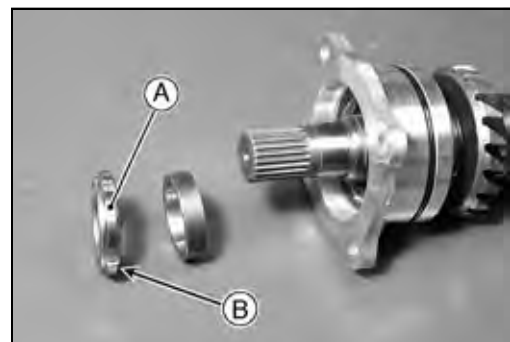

## Bevel Gear Case

### Drive Bevel Gear Removal

- Remove:
  - Hi/Low Gear Case
  - Drive Gear Nut [A]
- Special Tool - Transmission Gear Holder [B]: 57001-1364**

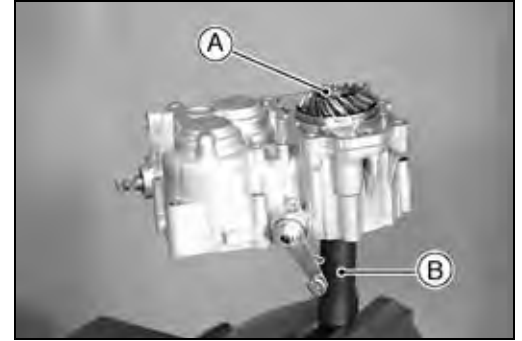

- Remove:
  - Drive Gear [A]
  - Drive Gear Shim(s) [B]
  - Drive Gear Shaft [C]

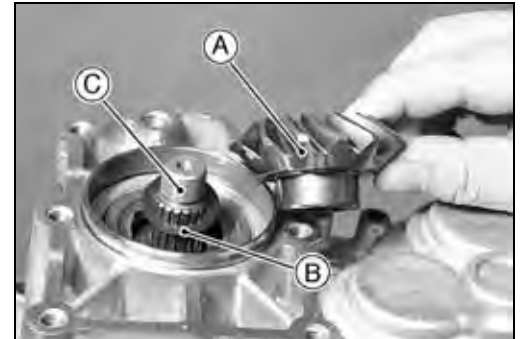

### Drive Bevel Gear Installation

- Check and adjust the bevel gear backlash and tooth contact when any of the backlash-related parts are replaced (see Bevel Gear Adjustment).
- Apply molybdenum disulfide oil:
  - Drive Gear Nut Seating Surface
- Torque - Drive Gear Nut: 120 N·m (12 kgf·m, 87 ft·lb)**

### Bevel Gear Adjustment

In order to prevent one gear from moving away from the other gear under load, the **backlash** and **tooth contact pattern** of the bevel gears must be correct to prevent the gears from making noise and being damaged.

When replacing any one of the backlash-related parts, be sure to check and adjust the backlash and tooth contact. First adjust the backlash, and then tooth contact by replacing shims.

These two adjustments are of critical importance and must be carried out in the correct sequence, using the procedures shown.

### Backlash Adjustment

- Check and adjust the gear backlash when any of the backlash-related parts are replaced with new ones.
- Install the drive gear with the primary shim and assemble the driven gear with the primary shim. Do not install the bevel gear case holder during adjustment.
- Clean any dirt and oil off the bevel gear teeth.
- Install the bevel gear case and tighten the case bolts.
- Check the backlash while tightening the case bolts. Stop tightening them immediately if the backlash disappears and change the shim to a thinner one.

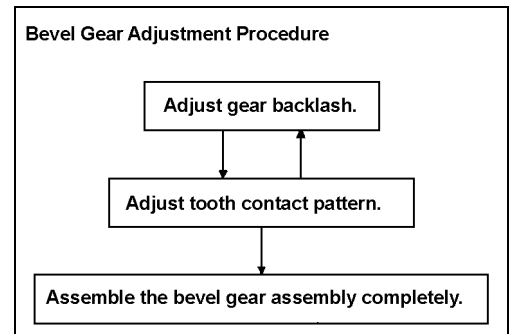

# 12-24 FINAL DRIVE

## Bevel Gear Case

- Set up a dial gauge [A] against one of the grooves in the locknut [B].
- To measure the backlash, turn the shaft clockwise and counterclockwise while holding the drive bevel gear steady. The difference between the highest and lowest gauge readings is the amount of backlash.

**Special Tool - Transmission Gear Holder [C]: 57001-1364**

- ★ If the backlash is not within the limit, replace the shim(s) at the drive and/or driven gear. To increase backlash, decrease the thickness of the shim(s). To decrease backlash, increase the thickness of the shim(s).
- ★ Change the thickness a little at a time.
- Recheck the backlash, and readjust as necessary.

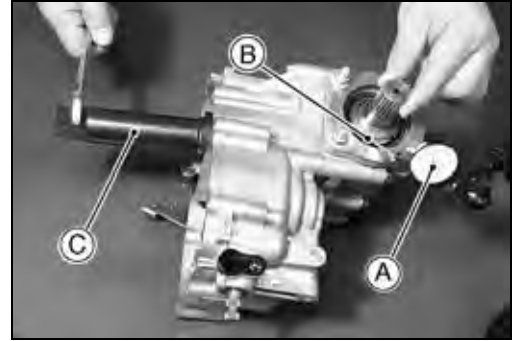

### Bevel Gear Backlash

**Standard:** 0.08 ~ 0.18 mm (0.0031 ~ 0.0071 in.)  
(at housing locknut groove)

### Bevel Gear Case (Backlash-Related Parts)

1. Driven Gear Shaft
2. Bearing Housing
3. Driven Gear Shim(s)
4. Bevel Gear Case
5. Ball Bearing
6. Driven Bevel Gear
7. Hi/Low Gear Case
8. Drive Gear Shaft
9. Ball Bearing
10. Drive Gear Shim(S)
11. Gasket
12. Drive Bevel Gear

#### Driven Gear Shims (3)

Thickness(mm)	Part Number
0.1	92025-1859
0.15	92025-1860
0.5	92025-1861
0.8	92025-1862
1.0(primary)	92025-1858
1.2	92025-1863

#### Drive Gear Shims (10)

Thickness(mm)	Part Number
0.15	92025-1573
0.2	92025-1574
0.7	92025-1534
0.8	92025-1535
0.9	92025-1536
1.0(primary)	92025-1537
1.1	92025-1575
1.2	92025-1538
1.3	92025-1533

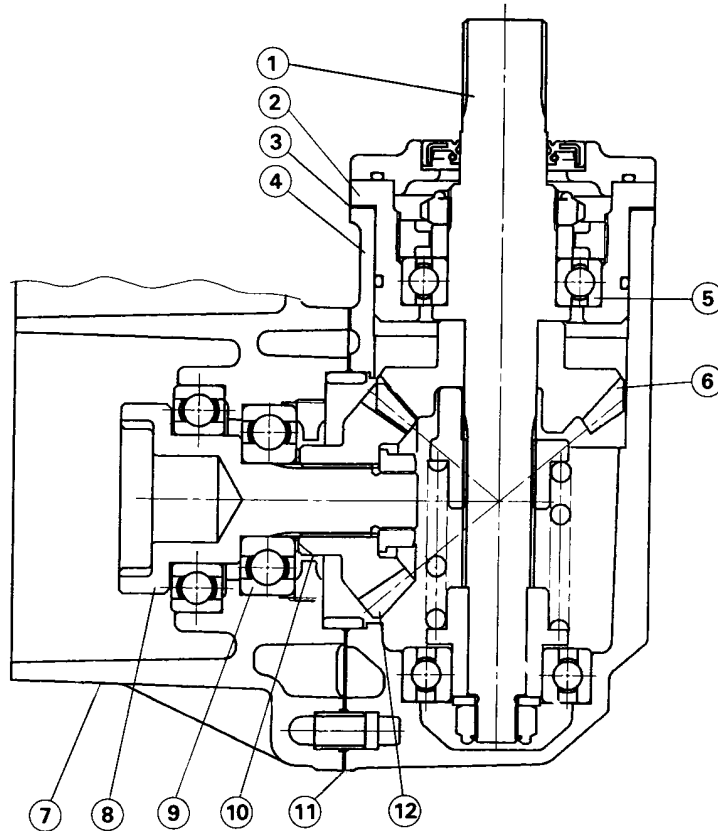

## Bevel Gear Case

### Tooth Contact Adjustment

- Clean any dirt and oil off the bevel gear teeth.
- Apply checking compound to 4 or 5 teeth on the driven bevel gear.

#### NOTE

- Apply checking compound to the teeth in a thin, even coat with a fairly stiff paint brush. If painted too thickly, the exact tooth pattern may not appear.
  - The checking compound must be smooth and firm with the consistency of tooth paste.
  - Special compounds are available from automotive supply stores for the purpose of checking differential gear tooth patterns and contact. Use this for checking the bevel gears.
- Turn the driven bevel gear for 3 or 4 turns in the drive and reverse (coast) directions, while creating a drag on the drive bevel gear.
  - Check the drive pattern and coast pattern of the bevel gear teeth. The tooth contact patterns of both drive and coast sides should be centrally located between the top and bottom of the tooth, and a little closer to the toe of the tooth.
  - ★ If the tooth contact pattern is incorrect, replace the shim(s) at the drive bevel gear and shim(s) at the driven bevel gear, following the examples shown. Then erase the tooth contact patterns, and check them again. Also check the backlash every time the shims are replaced. Repeat the shim change procedure as necessary.

#### NOTE

- If the backlash is out of the standard range after changing shims, correct the backlash before checking the tooth contact pattern.

- [A] Drive Bevel Gear
- [B] Driven Bevel Gear
- [C] Bottom
- [D] Top
- [E] Heel
- [F] Toe

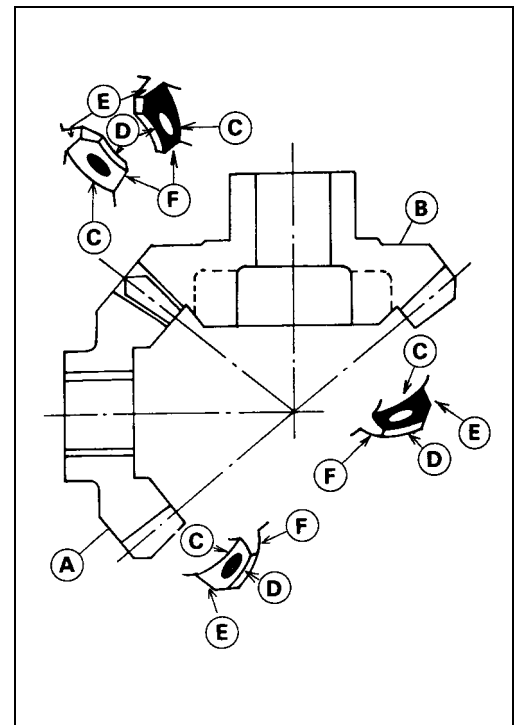

## 12-26 FINAL DRIVE

### Bevel Gear Case

#### Incorrect Tooth Contact Patterns

Example 1: Increase the thickness of the drive bevel gear shim(s) by 0.05 mm (0.002 in.), and/or increase the thickness of the driven bevel gear shim(s) by 0.05 mm (0.002 in.) to correct the pattern shown below. Repeat in 0.05 mm (0.002 in.) steps if necessary.

- [A] Drive Bevel Gear
- [B] Driven Bevel Gear
- [C] Bottom
- [D] Top
- [E] Heel
- [F] Toe

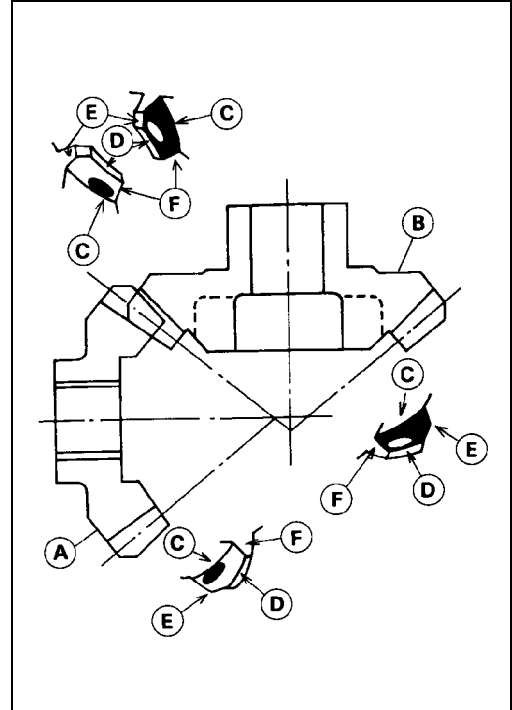

Example 2: Decrease the thickness of the drive bevel gear shim(s) by 0.05 mm (0.002 in.), and/or decrease the thickness of the driven bevel gear shim(s) by 0.05 mm (0.002 in.) to correct the pattern shown below. Repeat in 0.05 mm (0.002 in.) steps if necessary.

- [A] Drive Bevel Gear
- [B] Driven Bevel Gear
- [C] Bottom
- [D] Top
- [E] Heel
- [F] Toe

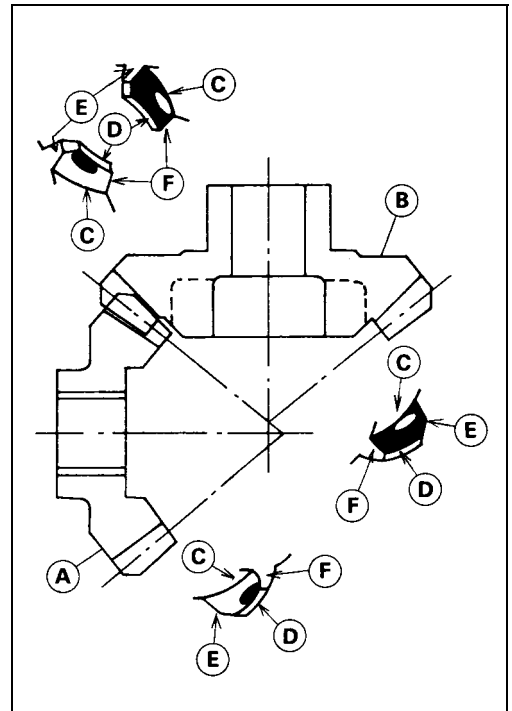



## Bevel Gear Case

### Bevel Gear Inspection

- Visually check the bevel gears [A] for scoring, chipping, or other damage.
- ★ Replace the bevel gears as a set if either gear is damaged.

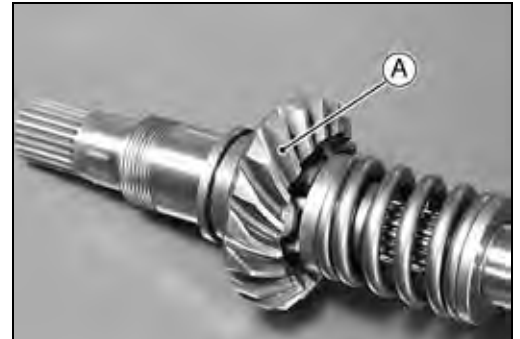

### Ball Bearing Inspection

- Since the ball bearings are made to extremely close tolerances, the wear must be judged by feel rather than measurement. Clean each bearing in a high flash-point solvent, dry it (do not spin the bearing while it is dry), and oil it with engine oil.
- Spin the bearing by hand [A] to check its condition.
- ★ If the bearing [B] is noisy, does not spin smoothly, or has any rough spots, replace it.

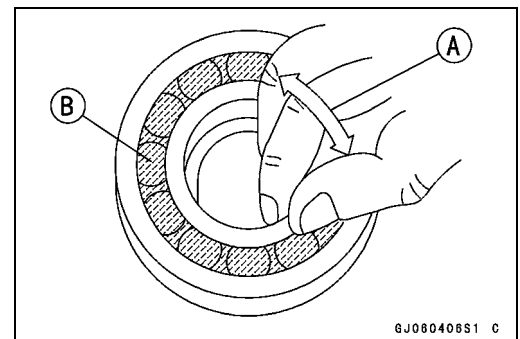

### Oil Seal Inspection

- Inspect the oil seals.
- ★ Replace it if the lips are misshapen, discolored (indicating that the rubber has deteriorated), hardened, or been otherwise damaged.

### Damper Inspection

- Visually inspect the driven bevel gear [A], cam follower [B], spring [C], and shaft [D].
- ★ Replace any part that appears damaged.

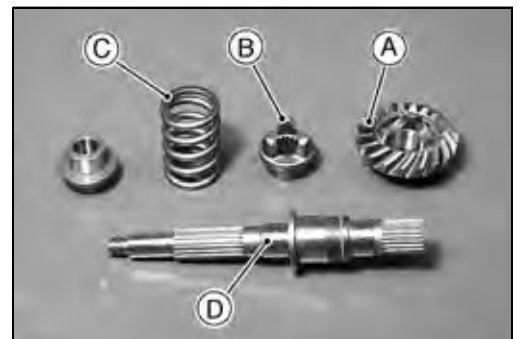

## 12-28 FINAL DRIVE

### Propeller Shafts

#### *Propeller Shaft Removal*

- Remove:
  - Fuel Tank (see Fuel System chapter)
  - Plate Screws [A]
  - Plate [B]
  
- Remove:
  - Water Pipe Bracket Bolts [A]
  
- Remove:
  - Propeller Shaft Bearing Housing Mounting Bolts [A] and Nuts
  
- Move the water pipe [A] and the propeller shaft bearing housing [B] to the outside [C].
- Remove:
  - Rear Propeller Shaft [D]
  - Front Propeller Shafts

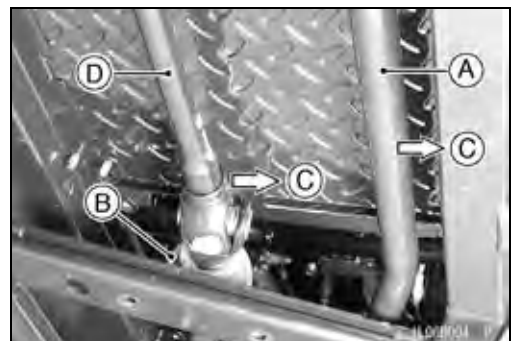
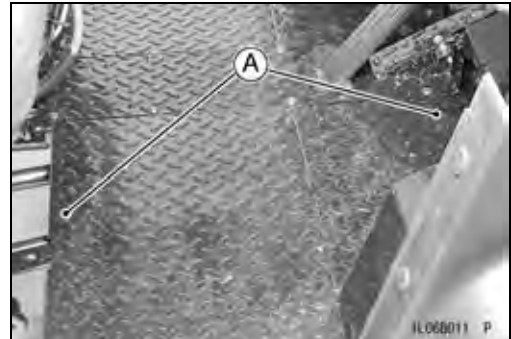
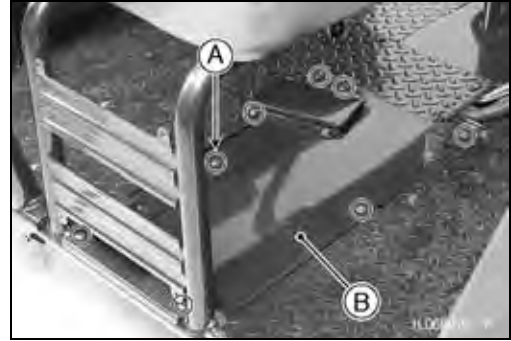

Propeller Shafts

*Propeller Shaft Installation*

- Wipe the old grease off the splines of the propeller shafts, and grease to them.
- Inspect the propeller shafts.
- Apply grease to the O-ring [A] on the front pinion gear.
- Install the front propeller shaft [B] on the front pinion gear.
- Install the rear propeller shaft [C] on the rear driven gear shaft.
- Install the rear propeller shaft front end [D] on the front propeller shaft rear end [E], aligning the yoke angles of the front and rear propeller shafts [F].
- Parallel [G] the propeller shaft bearing housing [H] with the mounting bracket [I], and tighten the mounting bolts and nuts.
- Make the 3 mm (0.12 in.) clearance [J] between the front propeller shaft and the front pinion gear nut [K].

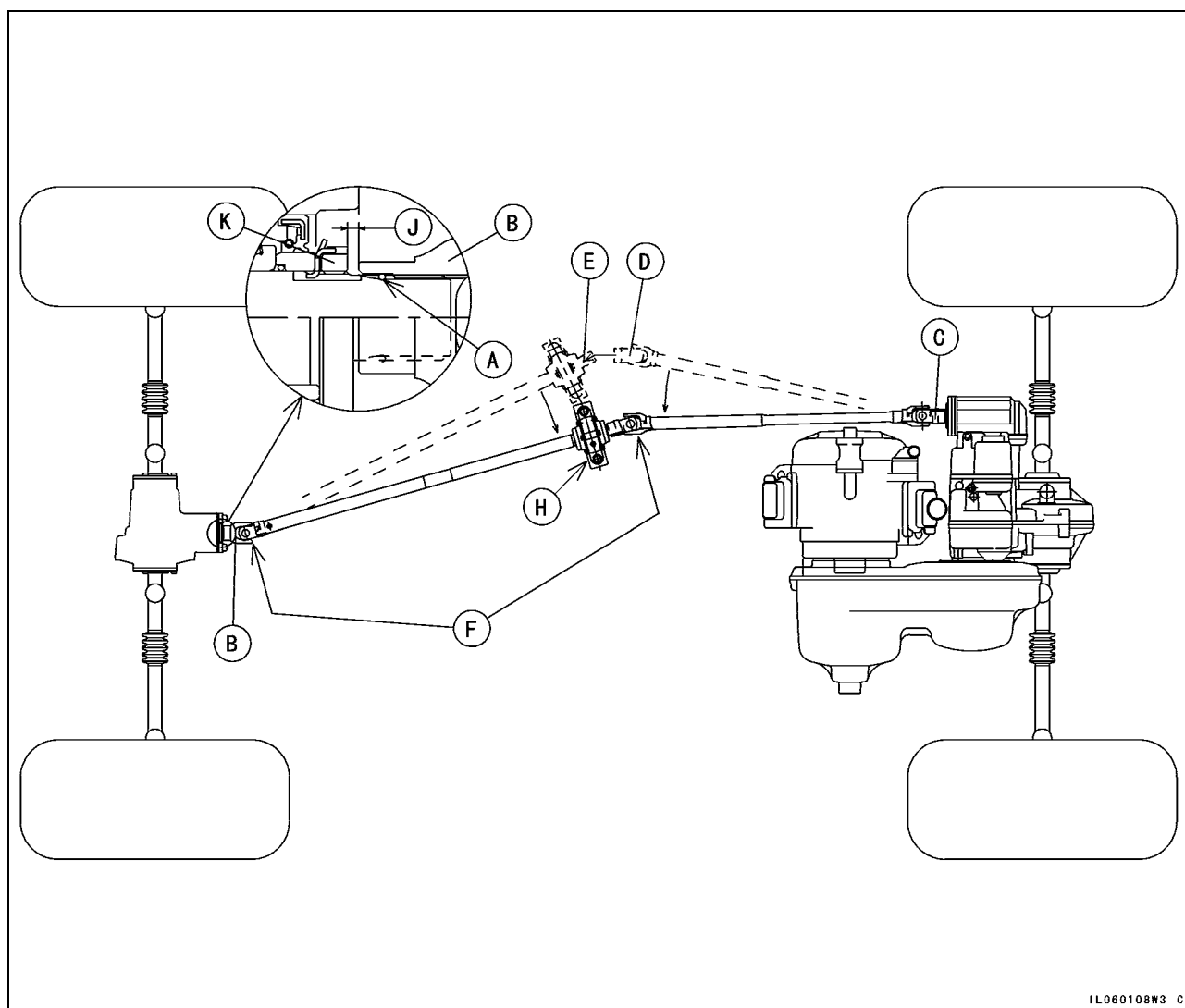
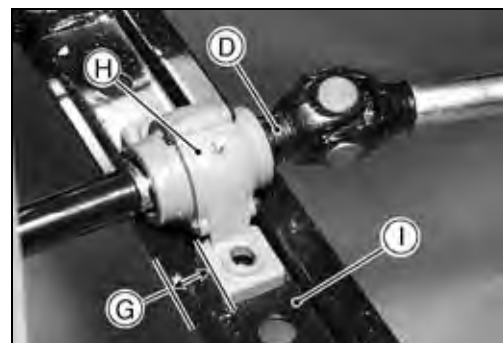

IL060108W3 C

## 12-30 FINAL DRIVE

---

### Propeller Shafts

---

#### *Propeller Shaft Inspection*

- Visually inspect the splines of the propeller shafts.
- ★ If they are twisted, badly worn, or chipped, replace the shafts.
- Check that the universal joint works smoothly without rattling or sticking.
- ★ If it does not, the bearings of the joint are damaged. Replace the propeller shaft with a new one.

## Drive Shaft and Axles

### Front Axle Removal

- Remove:
  - Steering Knuckle (see Steering chapter)
  - Radiator Side Cover
  - Front Axle Cap Bolts [A]
  - Front Axle [B]

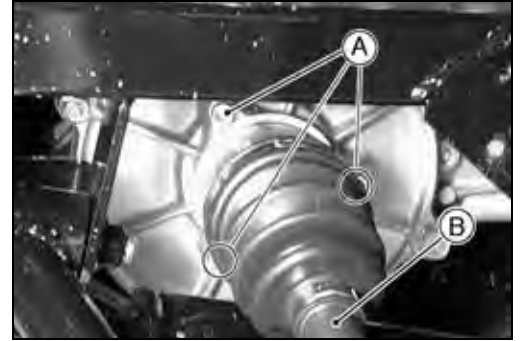

### Front Axle Installation

- Wipe the old grease off the splines of the axle and cap oil seal, and grease them.
- Inspect the axle.
- Be sure to install the spacer [A] and O-ring [B] in the recess of the front final gear case.
- Tighten:
  - Torque - Front Axle Cap Bolts: 8.8 N-m (0.90 kgf-m, 78 in-lb)**

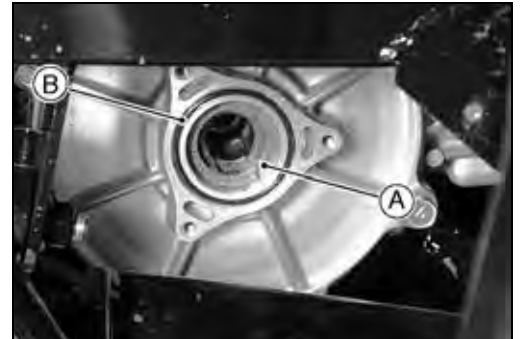

### Rear Drive Shaft and Axle Removal

- Remove:
  - Rear Wheels (see Wheels/Tires chapter)
  - Rear Brake Drums (see Brakes chapter)
  - Rear Brake Panel Assemblies (with Brake Pipes and Hoses)
  - Leaf Springs
  - Rubber Bands [A]
  - Axles [B] and Axle Bracket [C]
- Slide the dust boots [D] from the drive shafts [E], and pull the one of the axles from the drive shaft, and then the other axle from the shaft.
- Tap [A] the outside of the rear axle [B], and pull it out from the inside.

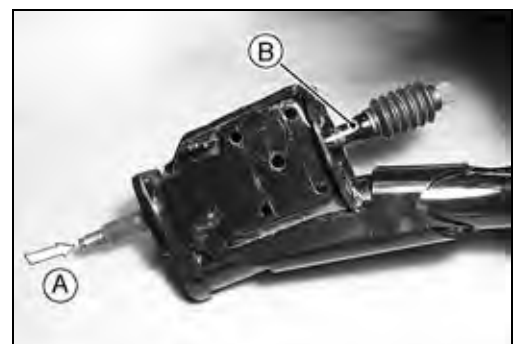
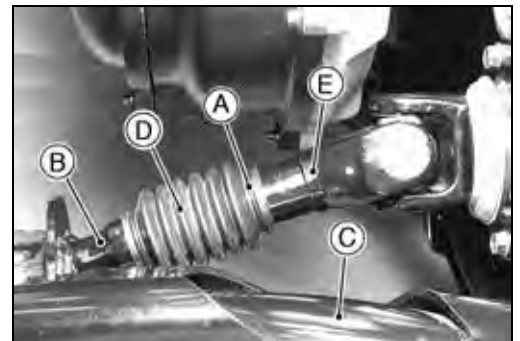

## 12-32 FINAL DRIVE

### Drive Shaft and Axles

- Remove:
  - Drive Shaft Cap Bolts [A]
  - Drive Shaft [B] and Cap [C]
- Set the differential shift lever into the UN-LOCK position.

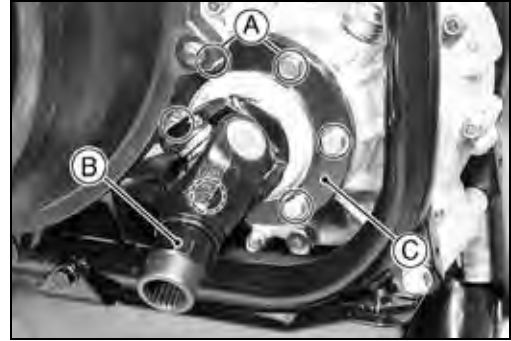

#### *Rear Drive Shaft and Axle Installation*

- Wipe the old grease off the splines of the drive shafts, axles, and cap oil seals, and grease them.
- Inspect the drive shafts and axles.
- Align the yoke angles of the drive shaft and axle.

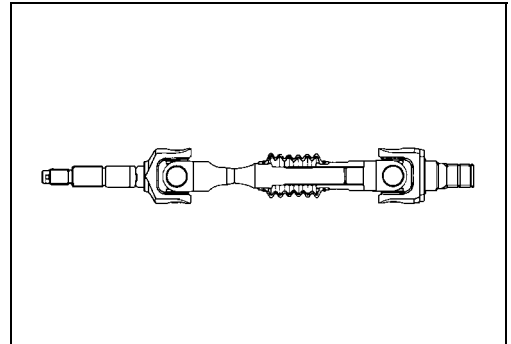

- ★ If the dust boot was removed, install it on the axle so that the small hole [A] in the boot is toward the axle side.
- Adjust:
  - Transmission Oil

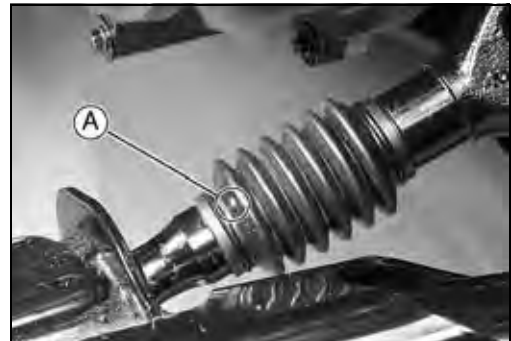

#### *Drive Shaft and Axle Inspection*

- Visually inspect the splines of the drive shaft and axle.
- ★ If they are twisted, badly worn, or chipped, replace the drive shaft and/or axle with a new one.
- Check that the universal joint and/or ball joint works smoothly without rattling or sticking.
- ★ If it does not, the bearings of the joint are damaged. Replace the drive shaft and/or axle with a new one.

## Drive Shaft and Axles

### Dust Boot Inspection

- Visually inspect the boots [A] in accordance with the Periodic Maintenance Chart or if the drive shafts or axles are noisy during operation.
- ★ If the dust boot is torn, worn, deteriorated, or leaks grease, replace it.

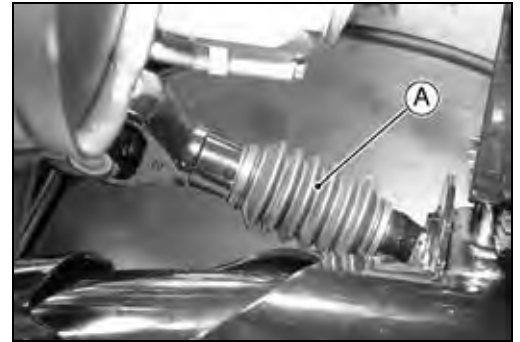
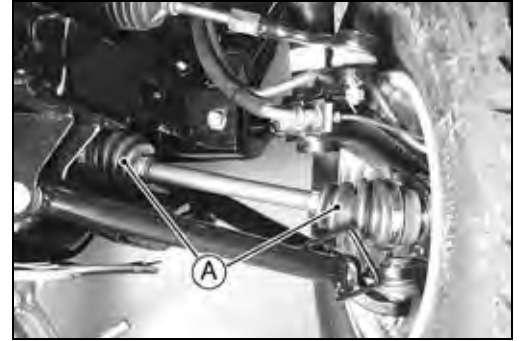

### Front Axle Joint Boot Replacement

- Remove:
  - Front Axle (see Front Axle Removal)
  - Circlip [A]
- **Special Tool - Outside Circlip Pliers [B]: 57001-144**
- Remove:
  - Collar [C]
  - Cap [D]
- Unlock the boot bands [A] for the inboard joint boot and move [B] the boot toward the outboard joint.

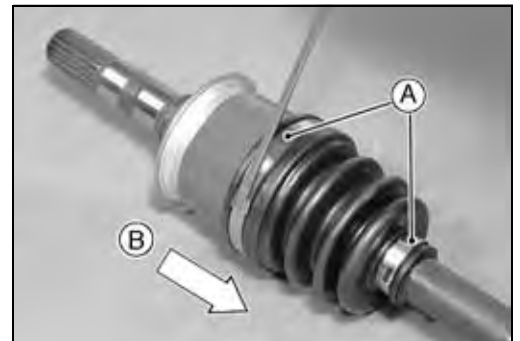
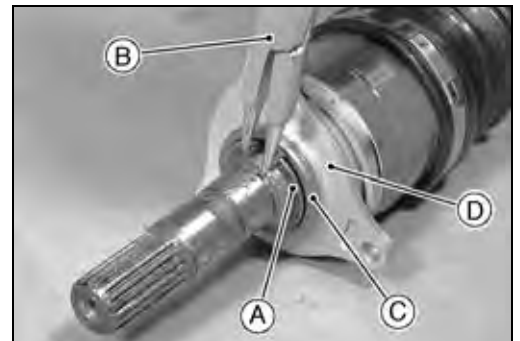

- Remove:
  - Retaining Ring [A]
- Separate the outboard shaft [B] from inboard shaft [C].

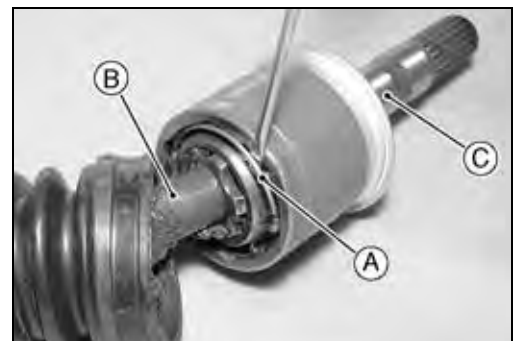

## 12-34 FINAL DRIVE

### Drive Shaft and Axles

- Remove the steel balls [A] with a screwdriver [B].
- Wipe the old grease.

<b>CAUTION</b>
----------------

<b>Do not reuse the old grease.</b>
-------------------------------------

- Move the steel ball holder [C] toward the outboard joint.

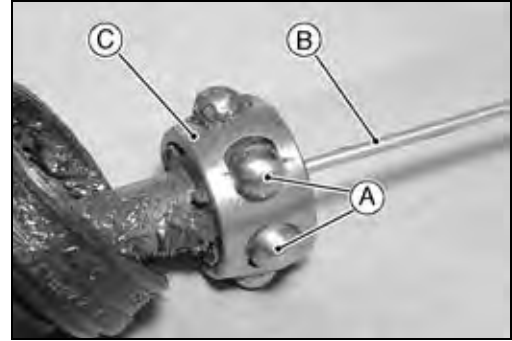

- Remove:
  - Circlip [A]
- Special Tool - Outside Circlip Pliers [B]: 57001-144
- Remove:
  - Steel Ball Base [C]

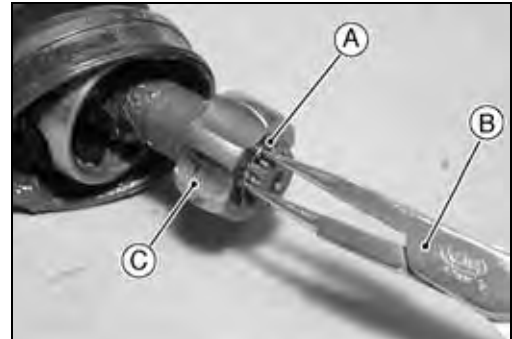

- Remove:
  - Inboard Joint Boot [A]
  - Boot Band [B]
- Discard the old grease.



- Unlock the boot band [A] for the outboard joint boot and remove the boot [B].

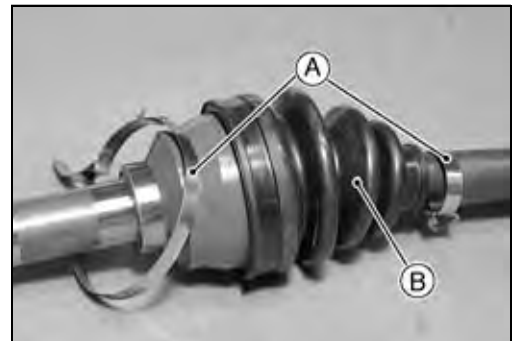

#### NOTE

○ *The outboard joint [A] can not be disassembled.*

- Wipe the old grease.

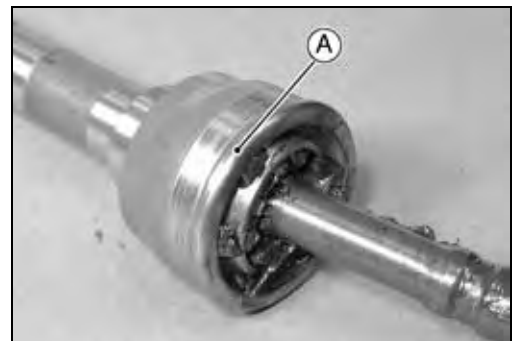



## Drive Shaft and Axles

- Check the universal joints.
- ★ If any joint does not work smoothly without rattling or sticking, the joint bearing is damaged. Replace the axle.
- Visually inspect the splines on the shaft.
- ★ If they are badly worn or chipped, replace the axle.
- Clean off the joint parts.

**CAUTION**

**Never clean the boots with mineral oil or gasoline because they will deteriorate the boot.**

- Replace the following parts with new ones.
  - Joint Boots
  - Circlip
  - Boot Bands
- Install:
  - Outboard Joint Boot [A]
- Pack the outboard joint with 40 ±10 g (1.4 ±0.4 oz) of the special grease.

**CAUTION**

**Be sure to use the special grease in the boot set.**

- Pour the grease in the outboard boot 1/3 ~ 1/2 the capacity of the boot.
- Install the outboard boot [A] on the outboard joint and shaft [B] properly as shown.
- Clamp the boot bands [C] and bend [D] the tangs [E] securely to hold down the end of the band.

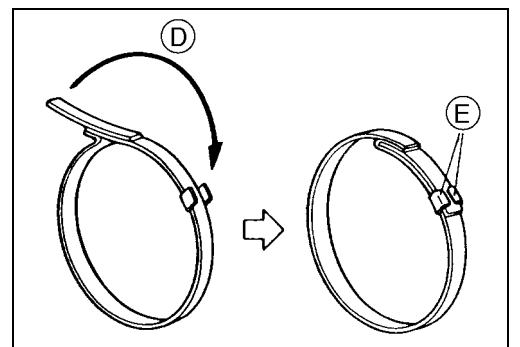
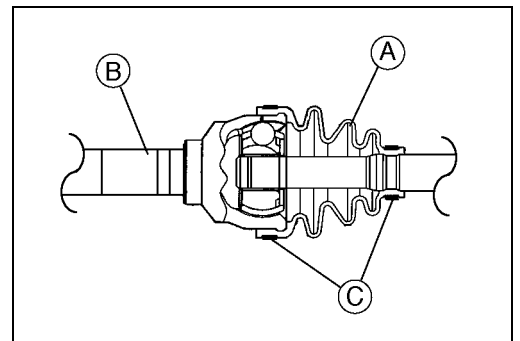

## 12-36 FINAL DRIVE

### Drive Shaft and Axles

- Install:

- Small Boot Band [A]
- Inboard Boot [B]
- Steel Ball Holder [C]
- Steel Ball Base [D]

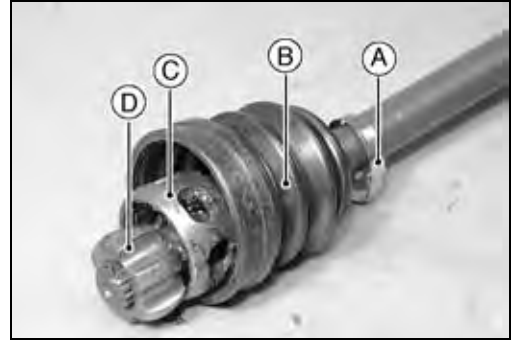

- Install the steel ball holder [A] as shown.
  - Face the chamfered side [B] of the steel ball base [C] to the boot.
- [D] Outboard Shaft

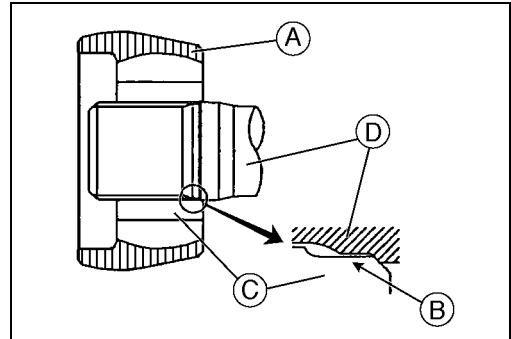

- Install:

- Circlip [A]
- Special Tool - Outside Circlip Pliers: 57001-144**



- Align the recesses of the steel ball base and holes in the steel holder, and install the steel balls [A].

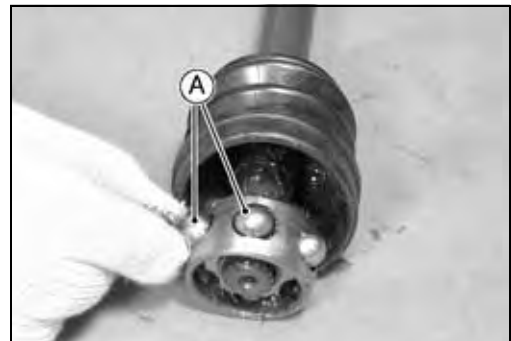

- Pack the inboard joint with 35 ±10 g (1.2 ±0.4 oz) of the special grease.
- Pour the special grease in the outboard shaft housing [A] about 25 g (0.9 oz).



**Drive Shaft and Axles**

- Install the retaining ring [A] so that the opening [B] is aligned with one of the projections [C].

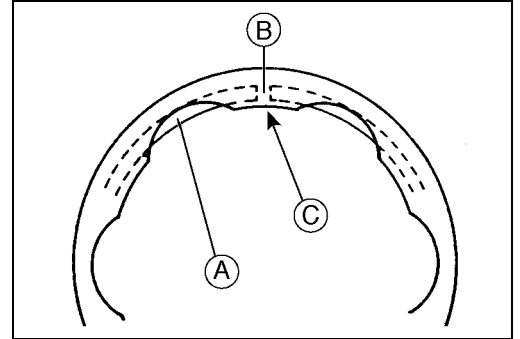

- Install the inboard boot [A] on the outboard joint and shaft [B] properly as shown.  
[C] 119 mm (4.69 in.)
- Clamp the small boot band [D] and bend the tang securely to hold down the end of the band.

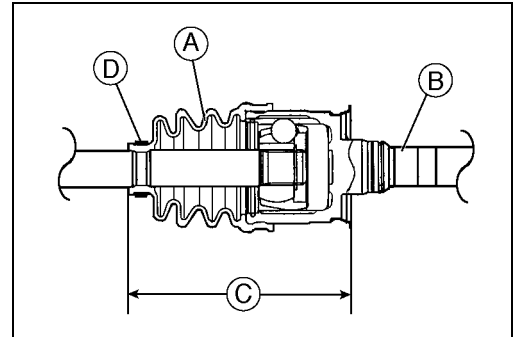

- Slightly open [A] the larger diameter end of the joint boot to equalize the air pressure inside the boot.



- Clamp the large boot band [A] and bend the tang securely to hold down the end of the band.



**Ball Bearing Inspection**

- Since the ball bearings are made to extremely close tolerances, the wear must be judged by feel rather than measurement. Clean each bearing in a high flash-point solvent, dry it (do not spin the bearing while it is dry), and oil it with engine oil.
- Spin the bearing by hand [A] to check its condition.
- ★ If the bearing [B] is noisy, does not spin smoothly, or has any rough spots, replace it.

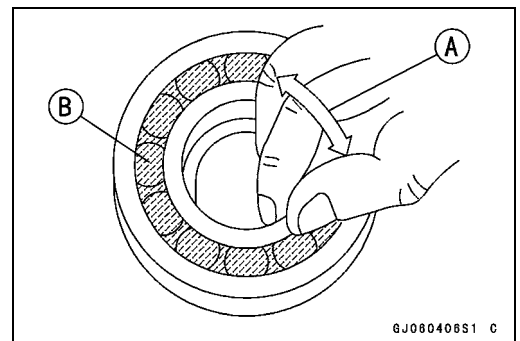

6J080408S1 C

## 12-38 FINAL DRIVE

---

### Drive Shaft and Axles

---

#### *Grease Seal Inspection*

- Visually inspect the grease seals.
- ★ Replace if the lips are misshapen, discolored (indicating that the rubber has deteriorated), hardened, or been otherwise damaged.

# Brakes

## Table of Contents

Exploded View .....	13-2
Specifications .....	13-6
Special Tools .....	13-7
Brake Fluid .....	13-8
Brake Fluid Recommendation.....	13-8
Brake Fluid Level Inspection.....	13-8
Brake Fluid Changing .....	13-8
Brake Line Air Bleeding .....	13-9
Brake Pedal and Master Cylinder .....	13-10
Brake Pedal Free Play Adjustment.....	13-10
Master Cylinder Removal.....	13-10
Master Cylinder Installation.....	13-10
Master Cylinder Disassembly .....	13-10
Master Cylinder Assembly .....	13-10
Master Cylinder Inspection .....	13-11
Brake Hoses and Pipes .....	13-12
Brake Hose and Pipe Inspection.....	13-12
Brake Hose and Pipe Replacement.....	13-12
Brake Drums.....	13-13
Brake Drum Removal.....	13-13
Brake Drum Installation.....	13-13
Brake Drum Wear .....	13-14
Brake Panel Assemblies.....	13-15
Brake Panel Removal .....	13-15
Brake Panel Installation .....	13-16
Wheel Cylinder Assembly .....	13-18
Wheel Cylinder Inspection .....	13-18
Brake Shoe Lining Wear .....	13-18
Brake Shoe Spring Inspection .....	13-19
Parking Brake Lever and Cables.....	13-20
Parking Brake Lever Travel Adjustment .....	13-20
Parking Brake Cable Lubrication .....	13-20
Parking Brake Cable Inspection.....	13-20

# 13-2 BRAKES

## Exploded View

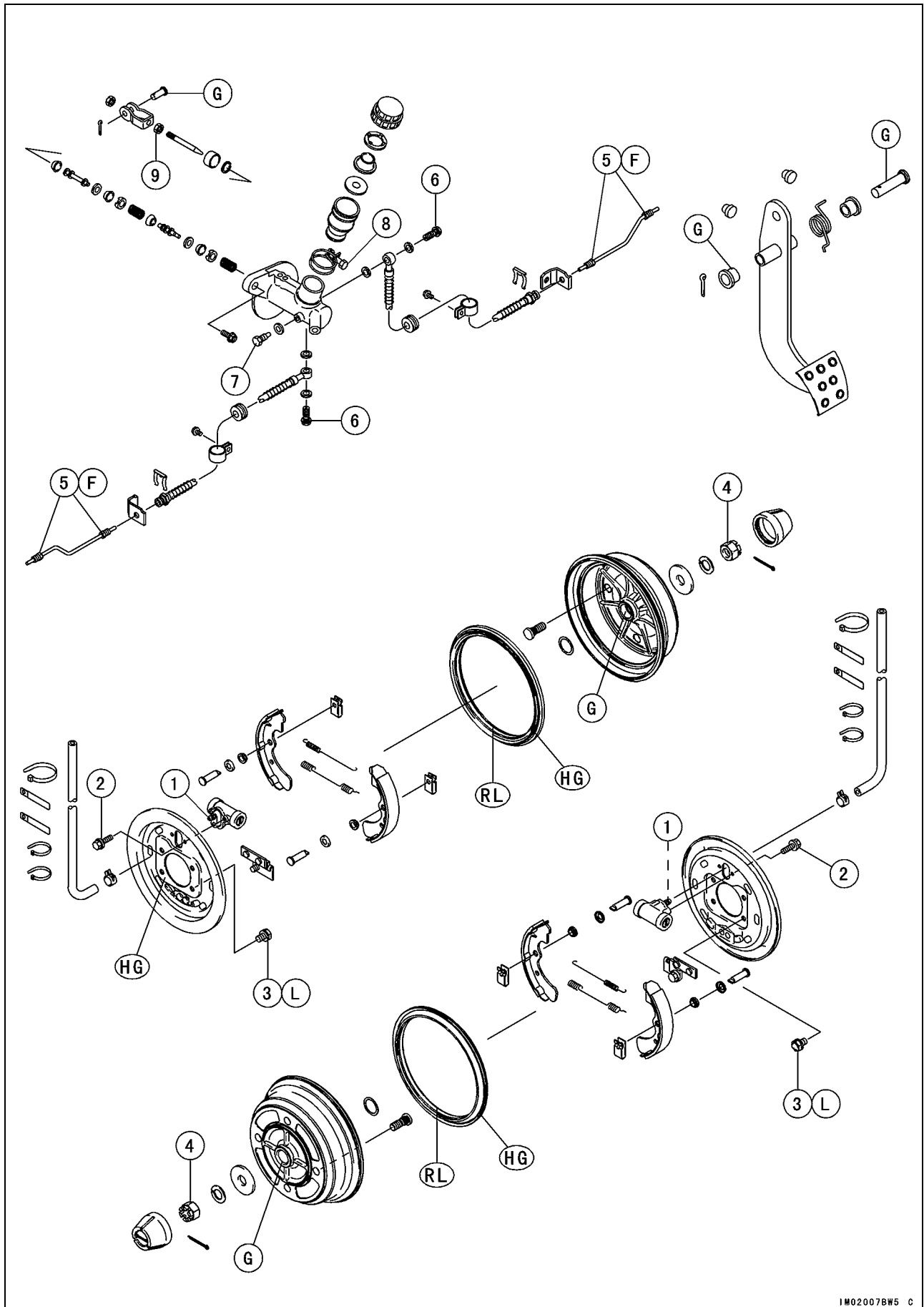

1M02007BW5 C

**Exploded View**

No.	Fastener	Torque			Remarks
		N·m	kgf·m	ft·lb	
1	Bleed Valves	5.9	0.60	52 in·lb	
2	Wheel Cylinder Mounting Bolts	11	1.1	95 in·lb	
3	Brake Panel Mounting Bolts	44	4.5	33	L
4	Front Axle Nuts	200	20	140	
5	Brake Pipe Nipples	18	1.8	13	F
6	Brake Hose Banjo Bolts	25	2.5	18	
7	Piston Stop Bolt	8.8	0.90	78 in·lb	
8	Reservoir Clamp Bolt	5.9	0.60	52 in·lb	
9	Push Rod Locknut	18	1.8	13	

F: Apply brake fluid.

G: Apply grease.

HG: Apply grease (Amoco Rykon Premium Grease No. 2 EP Green).

L: Apply a non-permanent locking agent.

RL: Apply rubber lubricating oil.

# 13-4 BRAKES

## Exploded View

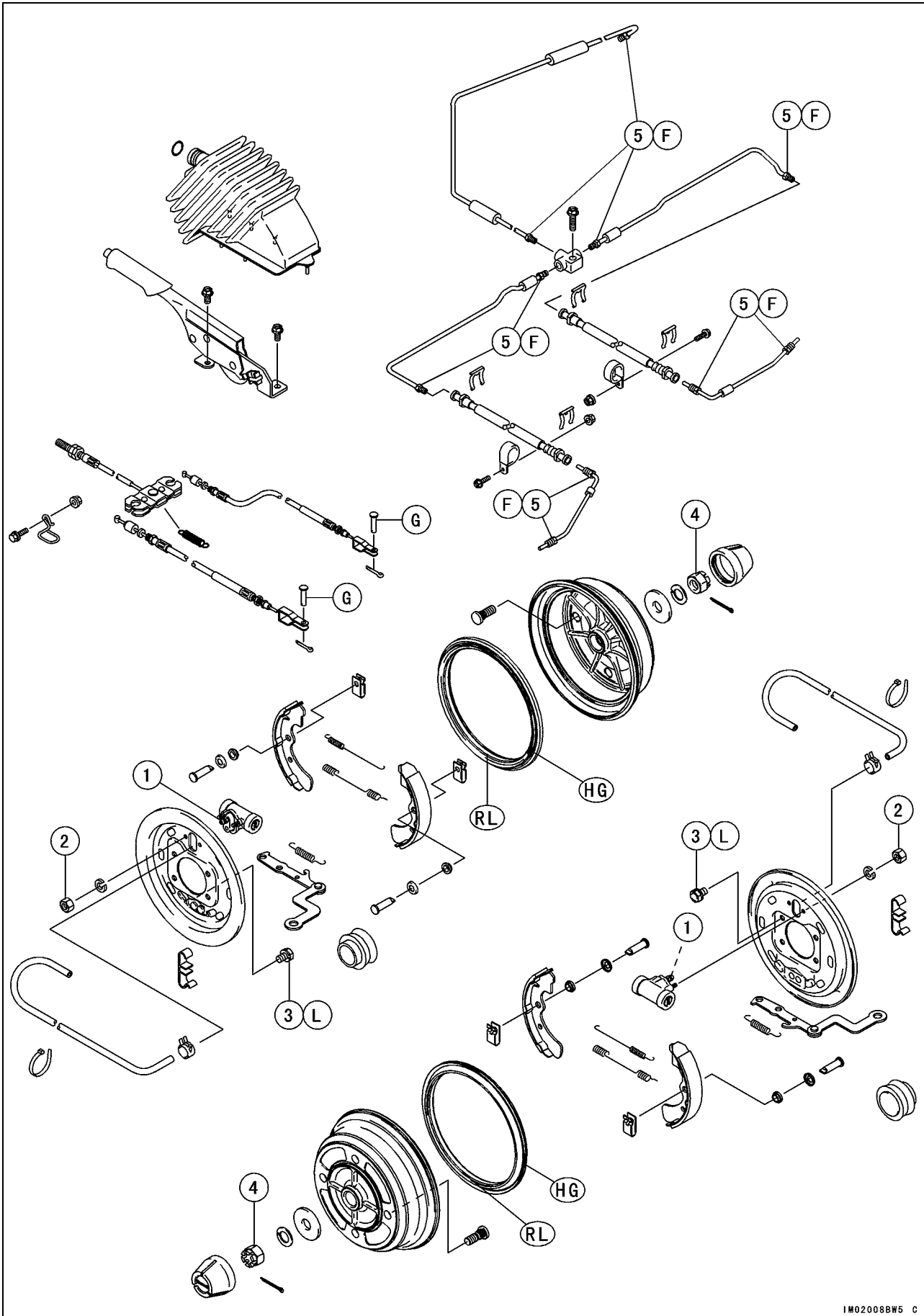

1M02008BW5 C



## Exploded View

No.	Fastener	Torque			Remarks
		N·m	kgf·m	ft·lb	
1	Bleed Valves	5.9	0.60	52 in·lb	
2	Wheel Cylinder Mounting Nuts	7.8	0.80	69 in·lb	
3	Brake Panel Mounting Bolts	44	4.5	33	L
4	Rear Axle Nuts	300	31	220	
5	Brake Pipe Nipples	18	1.8	13	F

F: Apply brake fluid.

G: Apply grease.

HG: Apply grease (Amoco Rykon Premium Grease No. 2 EP Green).

RL: Apply rubber lubricating oil.

## 13-6 BRAKES

### Specifications

Item	Standard	Service Limit
<b>Brake Fluid</b>		
Type	DOT3	---
Fluid level	Between upper and lower level lines	---
<b>Brake Pedal</b>		
Brake pedal free play	2 ~ 10 mm (0.08 ~ 0.39 in.)	---
<b>Brake Drums</b>		
Brake drum inside diameter	180.000 ~ 180.160 mm (7.0866 ~ 7.0929 in.)	180.75 mm (7.116 in.)
<b>Brake Panel Assemblies</b>		
Brake shoe lining thickness	4.5 mm (0.18 in.)	1.0 mm (0.04 in.)
<b>Parking Brake Lever and Cables</b>		
Parking brake lever travel	8 ~ 12 notches (clicks) at 200 N (20 kgf, 44 lb)	---

**Special Tools**

**Inside Circlip Pliers:**  
**57001-143**

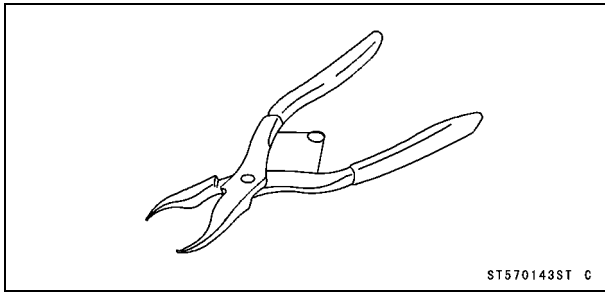

**Brake Drum Pusher, M18 x 1.5:**  
**57001-1261**

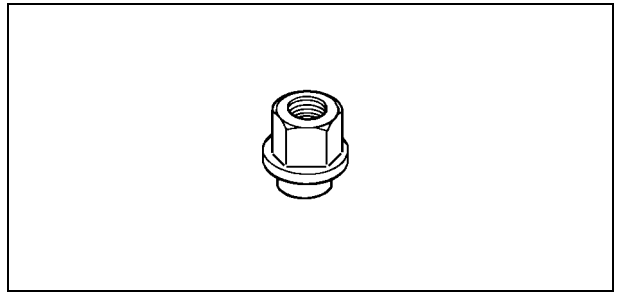

**Rotor Puller, M16/M18/M20/M22 x 1.5:**  
**57001-1216**

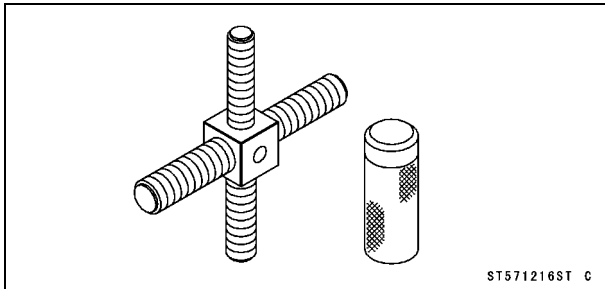

**Brake Drum Holder:**  
**57001-1325**

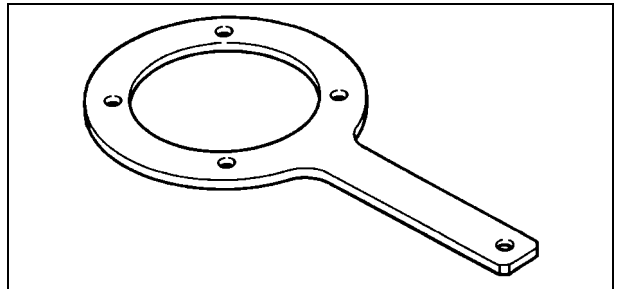

**Brake Drum Remover:**  
**57001-1260**

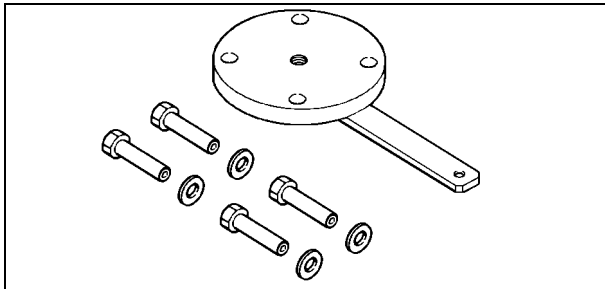

**Brake Drum Remover Nuts:**  
**57001-1326**

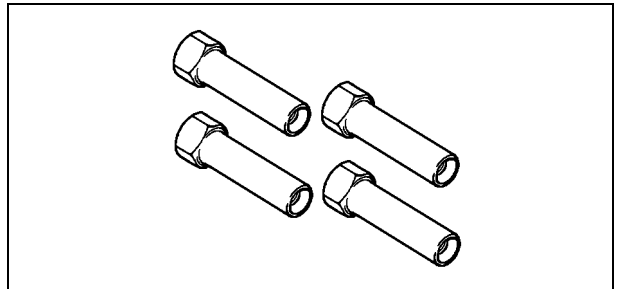

## 13-8 BRAKES

---

### Brake Fluid

---

#### *Brake Fluid Recommendation*

Use extra heavy-duty brake fluid only from a container marked DOT3.

#### **Recommended Brake Fluid**

Type: DOT3

#### **⚠ WARNING**

Never reuse old brake fluid.  
Do not use fluid from a container that has been left unsealed or that has been open for a long time.  
Do not mix two types and brands of fluid for use in the brake. This lowers the brake fluid boiling point and could cause the brake to be ineffective. It may also cause the rubber brake parts to deteriorate.  
Don't leave the reservoir cap off for any length of time to avoid moisture contamination of the fluid.  
Don't add or change the fluid in the rain or when a strong wind is blowing.  
If any of the brake line fittings or the bleed valve is opened at any time, the AIR MUST BE BLED FROM THE BRAKE LINE.

#### **CAUTION**

Brake fluid quickly ruins painted surfaces; any spilled fluid should be completely wiped up immediately.

#### *Brake Fluid Level Inspection*

- Refer to Brake Fluid Level Inspection in the Periodic Maintenance chapter.

#### *Brake Fluid Changing*

- Refer to Brake Fluid Changing in the Periodic Maintenance chapter.

## Brake Fluid

### *Brake Line Air Bleeding*

- Remove the maintenance cover.
- Check that there is plenty of fluid in the reservoir.

#### NOTE

○ *The fluid level must be checked several times during the bleeding operation and replenished as necessary. If the fluid in the reservoir runs completely out any time during bleeding, the bleeding operation must be done over again from the beginning since air will have entered the line.*

- With the reservoir cap off, slowly pump the brake pedal several times until no air bubbles can be seen rising up through the fluid from the holes at the bottom of the reservoir. This bleeds the air from the master cylinder end of the line.
- Remove the wheel for extra clearance.
- Connect a clear plastic hose to the bleed valve at the wheel cylinder, running the other end of the hose into a container.

#### NOTE

○ *Start with the rear left or right wheel and finish with the front left or right wheel.*

- Pump the brake pedal a few times until it becomes hard to pump. Hold the pedal in the down position. Quickly open (turn counterclockwise) and close the bleed valve. Then release the pedal. Repeat this operation until no more air can be seen coming out into the plastic hose.

1. Hold brake pedal applied.
2. Quickly open and close bleed valve.
3. Release brake pedal.

- Tighten:

**Torque - Bleed Valves: 5.9 N·m (0.60 kgf·m, 52 in·lb)**

- Repeat the previous step for each wheel.
- When air bleeding is finished, add fluid up to the upper level in the reservoir.
- Apply the brake forcefully for a few seconds, and check for fluid leakage around the fittings.
- Install the removed parts.



## 13-10 BRAKES

### Brake Pedal and Master Cylinder

#### *Brake Pedal Free Play Adjustment*

- Refer to Brake Pedal Free Play Adjustment in the Periodic Maintenance chapter.

#### *Master Cylinder Removal*

- Remove:
  - Front Fender Upper (see Frame chapter)
  - Brake Hose Banjo Bolts [A]
  - Brake Pipe Nipple [B] (unscrew)
- Immediately wipe up any brake fluid that spills.

#### **CAUTION**

**Brake fluid quickly ruins painted surfaces; any spilled fluid should be completely wiped up immediately.**

- Remove:
  - Master Cylinder Mounting Bolts [C]
  - Master Cylinder [D]

#### *Master Cylinder Installation*

- Use a new flat washer on each side of the brake hose fitting.
- Apply brake fluid:
  - Brake Pipe Nipple Threads
- Tighten:
  - Torque - Brake Hose Banjo Bolts: 25 N·m (2.5 kgf·m, 18 ft·lb)**
  - Brake Pipe Nipple: 18 N·m (1.8 kgf·m, 13 ft·lb)**
- Bleed the brake line after master cylinder installation.
- Adjust:
  - Brake Pedal Free Play Adjustment
- Check that the brake line has proper fluid pressure and no fluid leakage.

#### *Master Cylinder Disassembly*

- Refer to Brake Master Cylinder Cup and Dust Seal Replacement in the Periodic Maintenance chapter.

#### *Master Cylinder Assembly*

- Refer to Brake Master Cylinder Cup and Dust Seal Replacement in the Periodic Maintenance chapter.

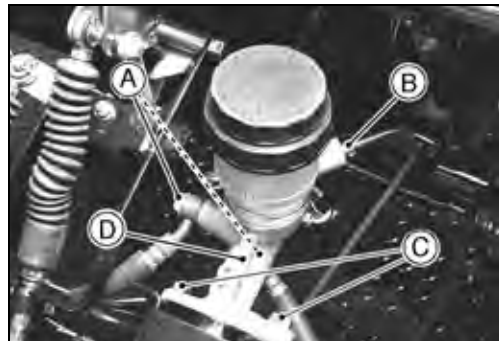

---

## Brake Pedal and Master Cylinder

---

### *Master Cylinder Inspection*

- Check that there are no scratches, rust or pitting on the inside of the cylinder and on the outside of the piston.
- ★ If the cylinder or piston shows any damage, replace them.
- Inspect the primary cups and secondary cups.
- ★ If a cup is worn, damaged, softened (rotted), or swollen, replace it.
- ★ If fluid leakage is noted at the brake push rod, the secondary cup of the rear piston should be replaced.
- Check the dust cover for damage.
- ★ If it is damaged, replace it.
- Check that the relief and supply ports are not plugged.
- ★ If the small relief port becomes plugged, the brake shoes will drag on the drum. Blow the ports clean with compressed air.
- Check the piston return springs for any damage.
- ★ If the spring is damaged, replace it.

## 13-12 BRAKES

---

### Brake Hoses and Pipes

---

#### *Brake Hose and Pipe Inspection*

- Refer to Brake Hose and Pipe Inspection in the Periodic Maintenance chapter.

#### *Brake Hose and Pipe Replacement*

- Refer to Brake Hose and Pipe Replacement in the Periodic Maintenance chapter.



## Brake Drums

### Brake Drum Removal

- Remove:
  - Wheel (see Wheel Removal)
  - Cotter Pin [A]
  - Axle Nut [B]
- Loosen the axle nut, while applying the brake, and release the brake.

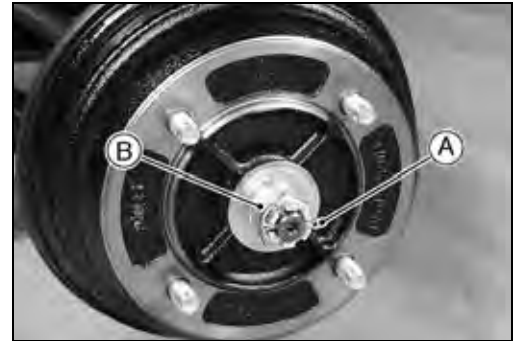

- The brake drums are press-fitted on the axles. Use the brake drum remover, stud nuts, and rotor puller (special tools) to remove the drums.
- Mount the brake drum remover on the drum studs with the stud nuts and washers (parts in the remover set).

**Special Tools - Rotor Puller, M16/M18/M20/M22 × 1.5: 57001-1216 [A]**

**Brake Drum Remover: 57001-1260 [B]**

**Brake Drum Remover Nuts: 57001-1326 [C]**

**Washers [D]**

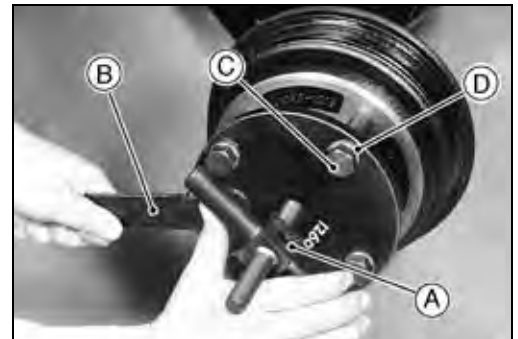

### Brake Drum Installation

- Observe the following procedure to install the brake drums. Replace the drum with a new one if its maximum press-fitting force (torque) is less than the service limit.

#### Drum Press-fitting Force (Torque)

**Service Limit: 20 N·m (2.0 kgf·m, 14 ft·lb)**

- Apply a molybdenum disulfide lubricant (grease or oil type, either will do) to the splines on the drum.
- Mount the brake drum holder [A] securely to the drum studs with the wheel nuts.
- Using the brake drum pusher [B], drive the drum onto the axle until the pusher stops.

**Special Tools - Brake Drum Pusher, M18 × 1.5: 57001-1261**

**Brake Drum Holder: 57001-1325**

- Apply a molybdenum disulfide lubricant (grease or oil type, either will do) to the threads and the seating face of the axle nut.
- Drive the drum further using the axle nut and washer instead of the pusher until the drum stops. At this time, use a torque wrench to turn the axle nut. Note the driving force (torque) of the nut.
- ★ The drum must be press-fitted on the axle. If the maximum torque for driving the nut is less than the service limit, the drum will not be tight enough and must be replaced.
- ★ If the maximum torque for driving the nut is more than the service limit, retighten the nut to the specified torque.
- Remove the brake drum holder.



## 13-14 BRAKES

### Brake Drums

- Grease (Amoco Rykon Premium Grease No.2 EP Green):  
Front Brake Drum Grease Seal Lips [A]
- Tighten:
- Do not press the drum bolts out.
- ★ If a drum bolt is damaged, replace the drum.

**Torque - Front Axle Nuts: 200 N·m (20 kgf·m, 140 ft·lb)**  
**Rear Axle Nuts: 300 N·m (31 kgf·m, 220 ft·lb)**



- Insert a new cotter pin [A].

#### NOTE

- When inserting the cotter pin, if the slots in the nut do not align with the cotter pin hole in the axle, tighten the nut clockwise [B] up to next alignment.
- It should be within 30 degree.
- Loosen once and tighten again when the slot goes past the nearest hole.

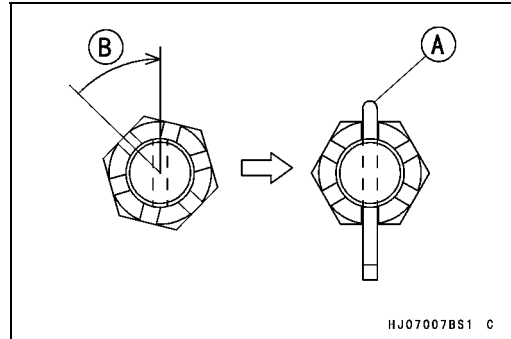

HJ07007BS1 C

- Bend the cotter pin [A] over the nut [B].

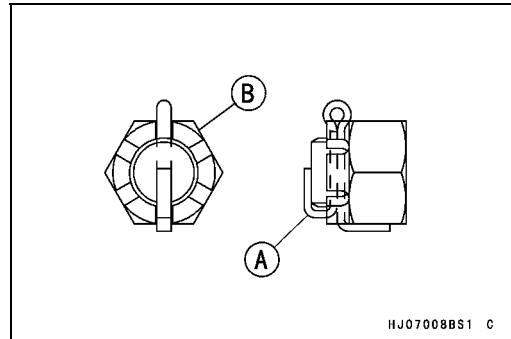

HJ07008BS1 C

#### Brake Drum Wear

- Refer to Brake Wear Inspection in the Periodic Maintenance chapter.

## Brake Panel Assemblies

### Brake Panel Removal

- Remove:
  - Brake Drum (see Brake Drum Removal)
  - Brake Pipe Nipple [A]
- Immediately wipe up any brake fluid that spills.

#### CAUTION

**Brake fluid quickly ruins painted surfaces; any spilled fluid should be completely wiped up immediately.**

- ★ Loosen the brake wheel cylinder mounting bolts [B] for the cylinder removal.
- ★ Remove the following for the brake panel assembly [A] removal.
  - Brake Panel Mounting Bolts [B]
  - Brake Panel Assembly

- Remove:
  - Brake Shoe Springs [A]
  - Brake Shoes [B]
- Push the shoe hold-down spring [C] and twist the pin [D] to remove them.

#### NOTE

○ Hold the brake shoes with a clean cloth to protect the linings from grease or dirt.

- Remove the collar [E] on the rear brake panel.

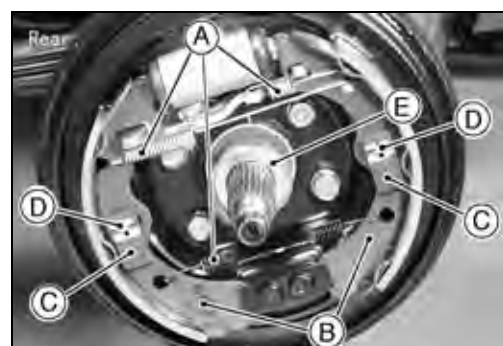
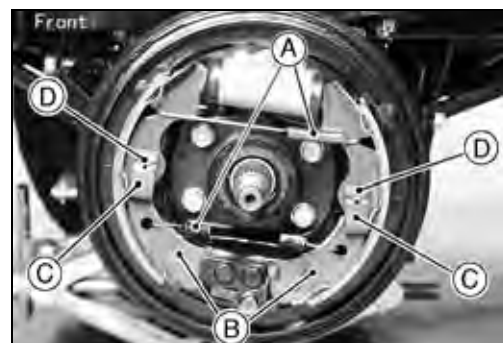
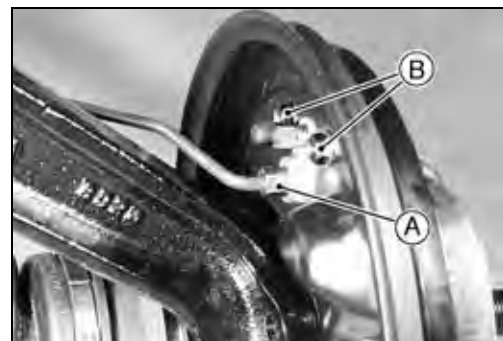

## 13-16 BRAKES

### Brake Panel Assemblies

- Remove the following for the rear brake panel removal.
  - Cotter Pin [A]
  - Clevis Pin [B]
  - Parking Brake Lever Linkage [C]

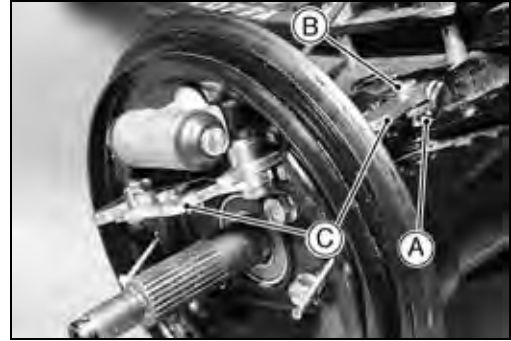

- Remove:
  - Brake Panel Mounting Bolts [A]
  - Brake Panel [B]



#### *Brake Panel Installation*

- Set the brake shoe clearance adjuster so that the drum can be re-installed on the panel assembly.
- Front brake; turn one of the wheel cylinder ends [A] while pushing it in. Keep the other end [B] from turning until both the ends of the pistons are back in the cylinder completely.
- Rear brake; pry the ratchet lever [A] with a screwdriver [B] to reset the shoe clearance adjuster in its original position [C].

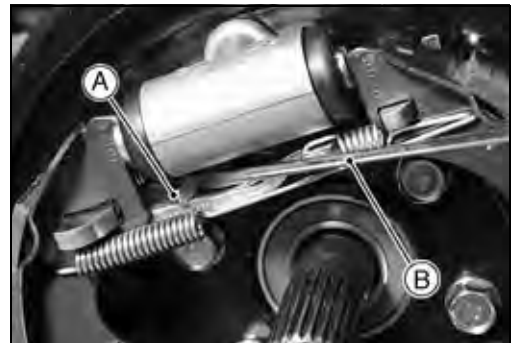

## Brake Panel Assemblies

- Grease (Amoco Rykon Premium Grease No. 2 EP Green):
  - Brake Panel Seating Surface
- Apply a non-permanent locking agent:
  - Brake Panel Mounting Bolts
- Apply brake fluid:
  - Brake Pipe Nipple Threads
- Tighten:
  - Torque - Wheel Cylinder Mounting Bolts: 11 N-m (1.1 kgf-m, 95 in-lb)**
  - Wheel Cylinder Mounting Nuts: 7.8 N-m (0.80 kgf-m, 69 in-lb)**
  - Brake Panel Mounting Bolts: 44 N-m (4.5 kgf-m, 33 ft-lb)**
  - Brake Pipe Nipple: 18 N-m (1.8 kgf-m, 13 ft-lb)**
- Grease [A]:
  - Brake Panel and Brake Shoe Contact Points
  - Wheel Cylinder Piston Ends
  - Brake Shoe Anchor Ends
- Grease (rear brake only) [B]:
  - Shoe Clearance Adjuster Pivots
  - Shoe Clearance Adjuster and Shoe Contact Points

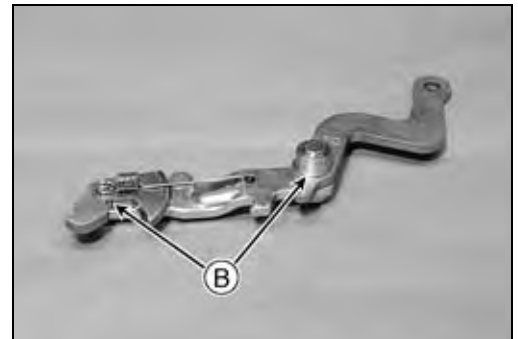

- Bleed the brake line after drum installation.
- Check the brake system to be sure there is adequate braking power. Also be sure there is no brake drag, or fluid leakage.

### **⚠ WARNING**

**Do not attempt to drive the vehicle until a complete brake pedal motion is obtained by pumping the brake pedal until the brake shoes contact the drum operating the shoe clearance adjuster until brake shoe to brake drum contact is made. The brake will not function on the first application of the pedal if this is not done.**

- Adjust:
  - Parking Brake Lever Travel Adjustment (see Parking Brake Lever Travel Adjustment)

## 13-18 BRAKES

### Brake Panel Assemblies

#### Wheel Cylinder Assembly

- Before assembly, clean all parts including the wheel cylinder with brake fluid or alcohol, and apply brake fluid to the removed parts and the inner wall of the cylinder.

#### CAUTION

**Use only brake fluid, isopropyl alcohol, or ethyl alcohol, for cleaning brake parts. Do not use any other fluid for cleaning these parts. Gasoline, motor oil, or any other petroleum distillate will cause deterioration of the rubber parts. Oil spilled on any part will be difficult to wash off completely, and will eventually deteriorate the rubber used in the brake.**

#### Wheel Cylinder Inspection

- Check that there are no scratches, rust or pitting on the inside of the cylinder and on the outside of the piston.
- ★ If the cylinder or piston shows any damage, replace the cylinder.
- Inspect the cups.
- ★ If a cup is worn, damaged, softened (rotted), or swollen, replace the cylinder.
- ★ If fluid leakage is noted at the dust covers, the cylinder should be replaced to renew the cup.
- Check the dust covers for damage.
- ★ If they are damaged, replace the cylinder.
- Check the spring for any damage.
- ★ If the spring is damaged, replace the cylinder.
- Front brake only: Check the brake shoe clearance adjuster for damage.
- ★ If it shows any damage, replace the cylinder.

Dust Cover [A]

Piston [B]

Cup [C]

Shoe Clearance Adjuster (Front) [D]

Spring (Rear) [E]

#### Brake Shoe Lining Wear

- Refer to Brake Wear Inspection in the Periodic Maintenance chapter.

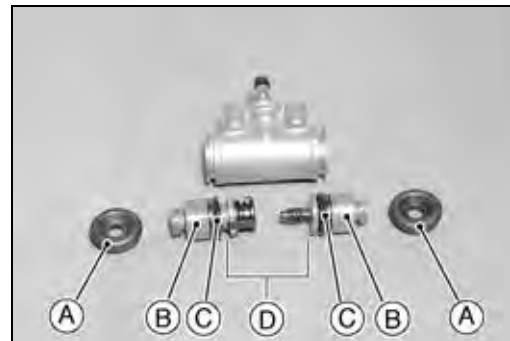

## Brake Panel Assemblies

### *Brake Shoe Spring Inspection*

- Visually inspect the brake shoe springs [A] for breaks or distortion.
- ★ If the springs are damaged in any way, replace them.



## 13-20 BRAKES

### Parking Brake Lever and Cables

#### *Parking Brake Lever Travel Adjustment*

- Refer to Parking Brake Lever and Cables in the Periodic Maintenance chapter.

#### *Parking Brake Cable Lubrication*

Whenever the parking brake cables are removed, lubricate the cables as follows.

- Apply a thin coating of grease to the cable upper ends.
- Lubricate the cable by seeping the oil between the cable and cable housing.

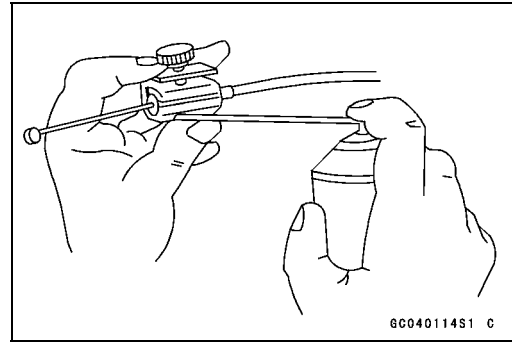

#### *Parking Brake Cable Inspection*

- With the cable disconnected at both ends, the cable should move freely [A] within the cable housing.
- ★ If the cable does not move freely after lubricating, or if the cable is frayed, or if the cable housing is kinked, replace the cable.

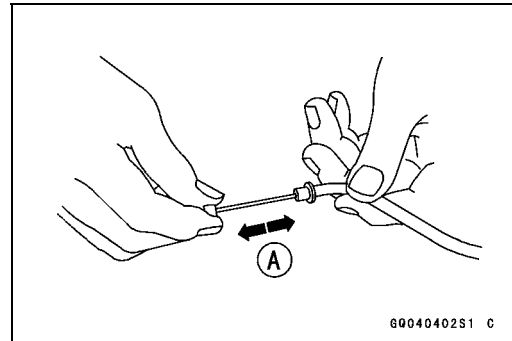



# Suspension

## Table of Contents

Exploded View.....	14-2
Specifications .....	14-4
Special Tool .....	14-5
Struts and Rear Shock Absorbers.....	14-6
Strut (Front Shock Absorber) Removal.....	14-6
Strut (Front Shock Absorber) Installation.....	14-6
Strut Spring Replacement.....	14-7
Rear Shock Absorber Preload Adjustment .....	14-8
Rear Shock Absorber Removal .....	14-9
Rear Shock Absorber Installation .....	14-9
Shock Absorber Inspection.....	14-9
Front Suspension Arms.....	14-10
Front Suspension Arm Removal.....	14-10
Front Suspension Arm Installation.....	14-10
Front Suspension Arm Inspection.....	14-11
Leaf Springs and Dampers.....	14-12
Leaf Spring Removal .....	14-12
Leaf Spring Installation .....	14-12
Leaf Spring Inspection .....	14-13

# 14-2 SUSPENSION

## Exploded View

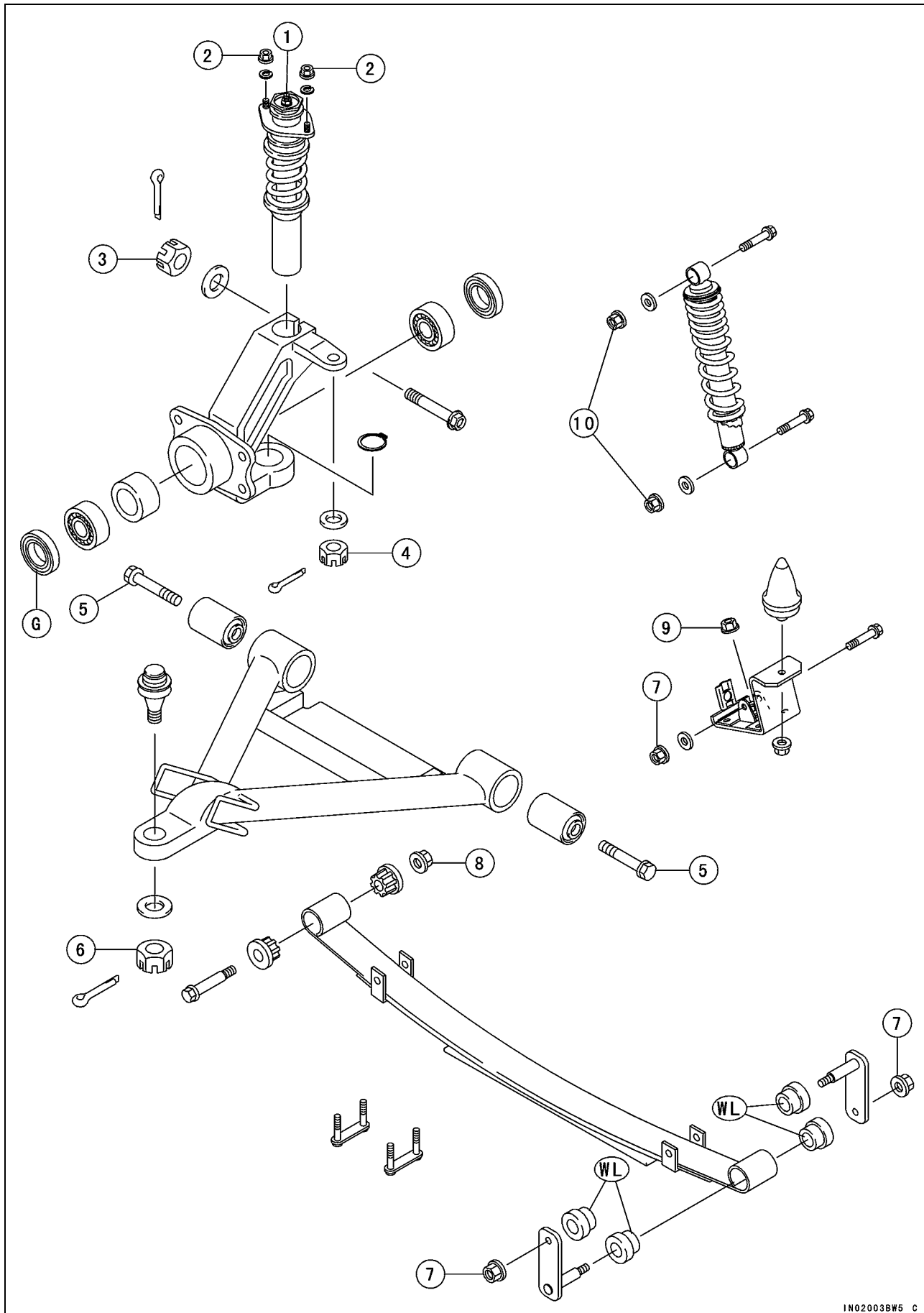

**Exploded View**

No.	Fastener	Torque			Remarks
		N·m	kgf·m	ft·lb	
1	Strut Locknut	49	5.0	36	
2	Strut Mounting Nuts	44	4.5	33	
3	Strut Clamp Nut	98	10	72	
4	Tie-rod End Nuts	34	3.5	25	
5	Front Suspension Arm Pivot Bolts	98	10	72	
6	Front Suspension Arm Joint Nut	78	8.0	58	
7	Leaf Spring Mounting Nuts (Rear)	59	6.0	43	
8	Leaf Spring Mounting Nuts (Front)	98	10	72	
9	Damper Bracket Mounting Nuts	44	4.5	33	
10	Rear Shock Absorber Mounting Nuts	59	6.0	43	

G: Apply grease.

WL: Apply soap and water solution.

## 14-4 SUSPENSION

### Specifications

Item	Standard	Service Limit
<b>Rear Shock Absorbers</b> Spring Preload Setting Position	3rd position	<b>(Usable Range)</b> 1 ~ 5 positions

---

**Special Tool**

---

**Steering Stem Nut Wrench:  
57001-1100**

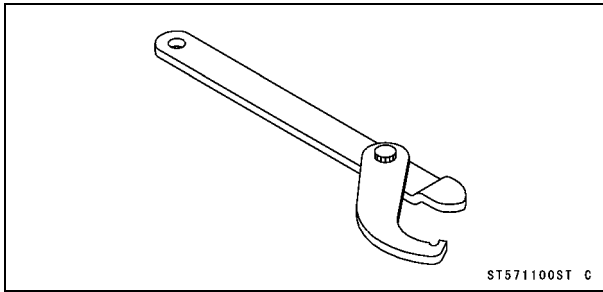

## 14-6 SUSPENSION

### Struts and Rear Shock Absorbers

#### Strut (Front Shock Absorber) Removal

- Remove:
  - Front Fender Upper (see Frame chapter)
  - Front Wheel (see Wheels/Tires chapter)
  - Brake Panel (see Brakes chapter)
  - Brake Hose Retainer [A]
  - Brake Hose [B] (from Bracket)
  - Strut Clamp Bolt and Nut [C]

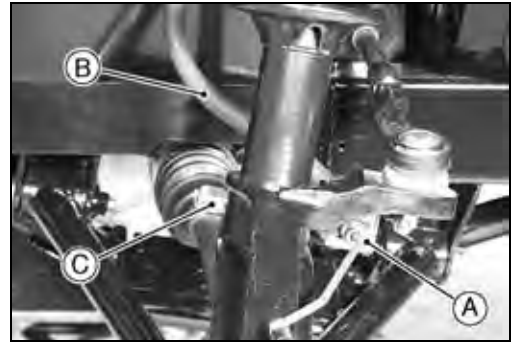

- Remove:
  - Strut Mounting Nuts [A]

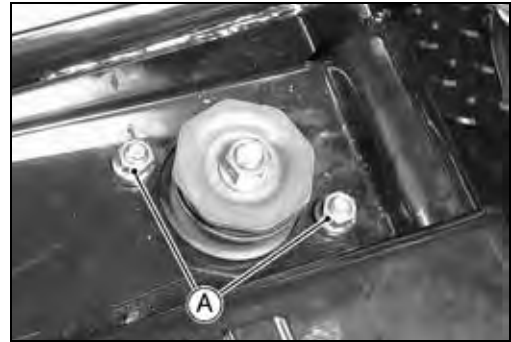

- Remove the strut [A] from the steering knuckle [B].  
[C] Front

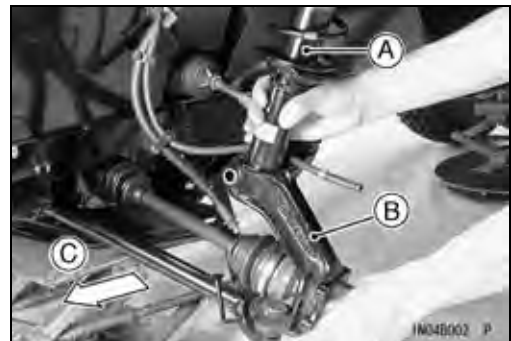

#### Strut (Front Shock Absorber) Installation

- Insert the strut to the steering knuckle [A] while aligning the notch [B] on the strut with the clamp bolt hole [C] on the steering knuckle.
- Tighten:
  - Torque - Strut Mounting Nuts: 44 N-m (4.5 kgf-m, 33 ft-lb)**
  - Strut Clamp Nut: 98 N-m (10 kgf-m, 72 ft-lb)**

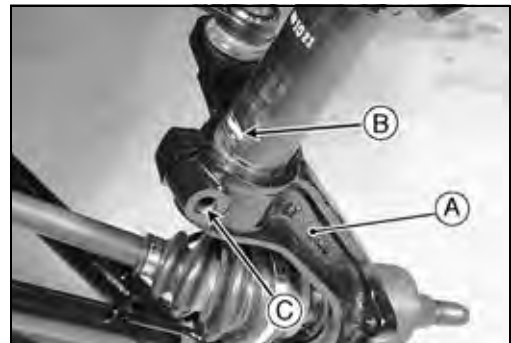

- Insert a new cotter pin [A].

#### NOTE

- When inserting the cotter pin, if the slots in the nut do not align with the cotter pin hole in the axle, tighten the nut clockwise [B] up to next alignment.
- It should be within 30 degree.
- Loosen once and tighten again when the slot goes past the nearest hole.

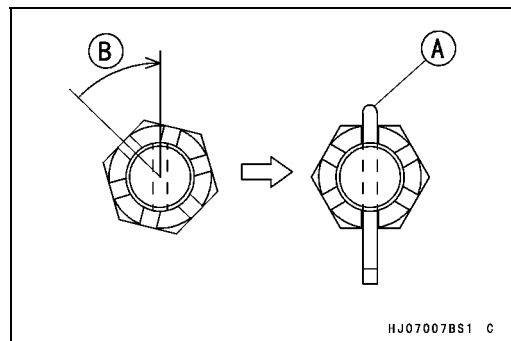

HJ07007BS1 C

**Struts and Rear Shock Absorbers**

- Bend the cotter pin [A] over the nut [B].

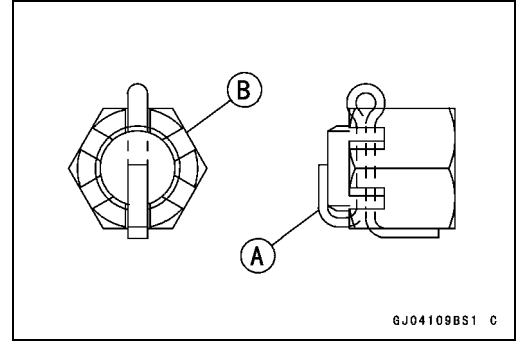

**Strut Spring Replacement**

In addition to the standard springs, hard springs are available.

The hard springs stiffen the strut action and accelerate the rebound damping.

- Remove:
  - Strut (see Strut Removal)
- Hold the large washer [A] in a vise [B].
- Remove:
  - Locknut [C] and Small Washer
  - Large Washer
- Remove:
  - Holder [A]
  - Thrust Plate [B]
  - Dust Seal
  - Thrust Washer
  - Upper Spring Seat [C]
  - Dust Cover [D]
  - Spring [E]

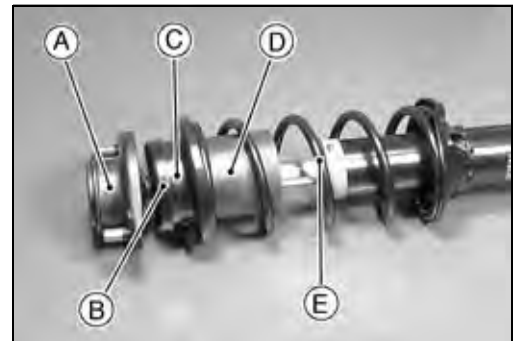
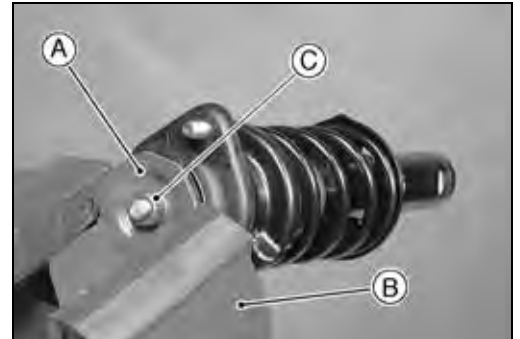

- Install the replaced spring.
  - Fit the spring end [A] to the bulge [B] in the lower spring seat [C].

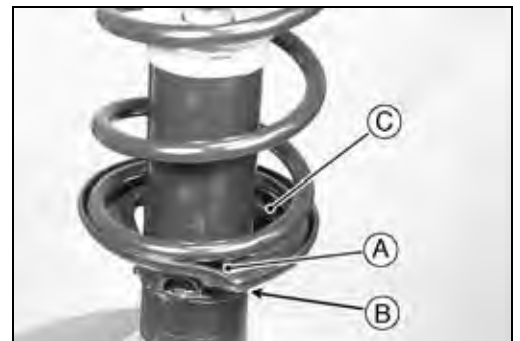

- Install:
  - Dust Cover [A]
  - Upper Spring Seat [B]
- Fit the spring end to the bulge [C] in the dust cover and upper spring seat.

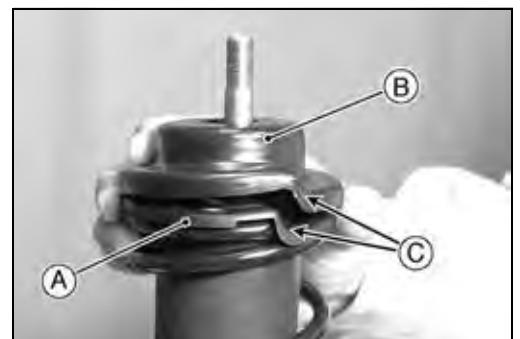

## 14-8 SUSPENSION

### Struts and Rear Shock Absorbers

- Apply grease to the upper and lower side on the following parts, and install them.

Dust Seal [A]

Thrust Washer [B]

- Face the projection on the thrust washer downward.

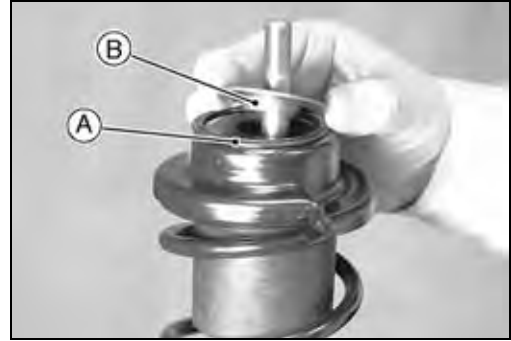

- Install:

Holder [A]

Large Washer [B]

Small Washer [C]

Lock Nut [D]

- Push down the holder, and tighten the locknut.

**Torque - Strut Locknut: 49 N·m (5.0 kgf·m, 36 ft·lb)**

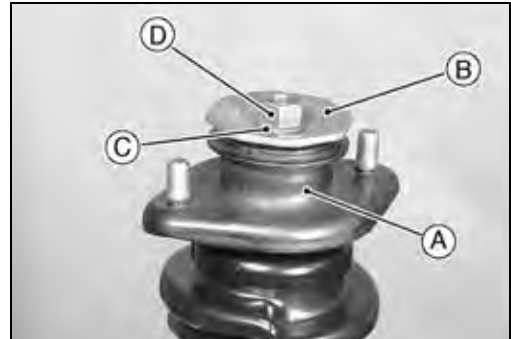

#### Rear Shock Absorber Preload Adjustment

The spring adjusting sleeve [A] on the rear shock absorbers have 5 positions so that the springs can be adjusted for different terrain and loading conditions. If the spring action feels too soft or too stiff, adjust it in accordance with the following table.

#### Spring Action

Position	Spring Force	Setting	Load	Terrain	Speed
1	↓ Stronger	Soft	Light	Smooth	Low
2		↑	↑	↑	↑
3 (STD)					
4		↓	↓	↓	↓
5		Hard	Heavy	Rough	High

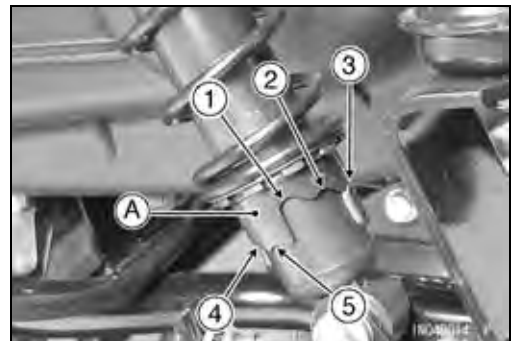

- Turn the adjusting sleeve on each rear shock absorber to the desired position with the wrench [A].

**Special Tool - Steering Stem Nut Wrench: 57001-1100**

- Both adjusting sleeves (left and right) must be turned to the same relative position.



#### **⚠ WARNING**

**If both adjusting sleeves are not adjusted equally, handling may be impaired and a hazardous condition may result.**



---

## Struts and Rear Shock Absorbers

---

### *Rear Shock Absorber Removal*

- Remove:
  - Rear Wheel (see Wheels/Tires chapter)
- Remove:
  - Rear Shock Absorber Mounting Bolts and Nuts [A] (while moving the frame up or down with a jack)
  - Rear Shock Absorber [B]

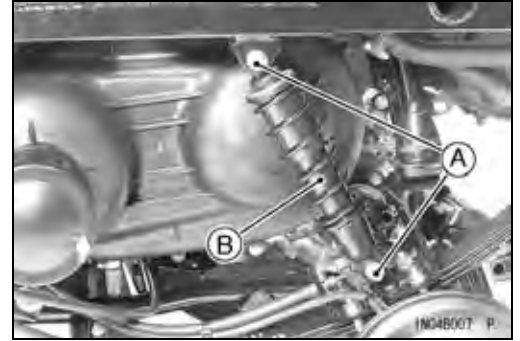

### *Rear Shock Absorber Installation*

- Install the rear wheel temporarily and ground it to load the suspension.
- Tighten:
  - Torque - Rear Shock Absorber Mounting Nuts: 59 N·m (6.0 kgf·m, 43 ft·lb)**

### *Shock Absorber Inspection*

- Visually inspect the shock absorber for breaks or distortion.
- ★ If the shock absorber is damaged in any way, replace it.
- Check for oil leakage at the shock absorber damper unit.
- ★ If oil leakage is noted, the shock absorber should be replaced to renew the oil seal.
- Visually inspect the rubber bushings in the upper and/or lower mountings of the rear shock absorber.
- ★ If they are worn, cracked, hardened, or otherwise damaged, replace them with new ones.

## 14-10 SUSPENSION

### Front Suspension Arms

#### Front Suspension Arm Removal

- Remove:
  - Front Wheel (see Wheels/Tires chapter)
- Hold the front brake drum and panel assembly in position.
- Remove:
  - Front Suspension Arm Pivot Bolts [A]



- Remove:
  - Front Suspension Arm Joint Nut [A]
  - Front Suspension Arm Joint from Steering Knuckle
- Install a suitable nut on the stud of the joint and tap the nut to free the joint from the steering knuckle.
- Remove:
  - Front Suspension Arm [B]



#### Front Suspension Arm Installation

- Clean the tapered portion of the front suspension arm joint and the tapered hole of the steering knuckle, or the tapers will not fit snugly.
- Grease:
  - Front Suspension Arm Joint Boot Sealing Surface [A]
- When the front suspension arm pivot bolts are tightened, install the arm joint to the steering knuckle to position the arm within its operating angle.
- Tighten:

**Torque - Front Suspension Arm Pivot Bolts: 98 N-m (10 kgf-m, 72 ft-lb)**

**Front Suspension Arm Joint Nut: 78 N-m (8.0 kgf-m, 58 ft-lb)**

- Insert a new cotter pin [A].

#### NOTE

- When inserting the cotter pin, if the slots in the nut do not align with the cotter pin hole in the axle, tighten the nut clockwise [B] up to next alignment.
- It should be within 30 degree.
- Loosen once and tighten again when the slot goes past the nearest hole.

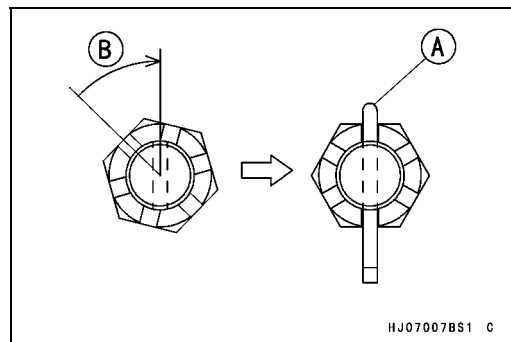
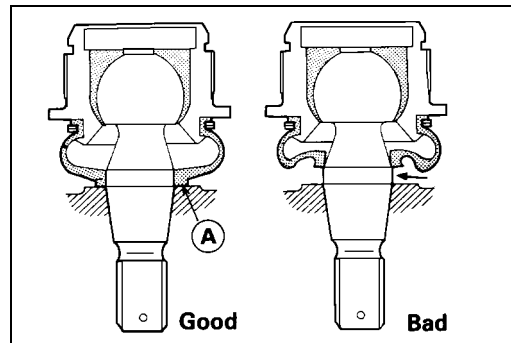

### Front Suspension Arms

- Bend the cotter pin [A] over the nut [B].

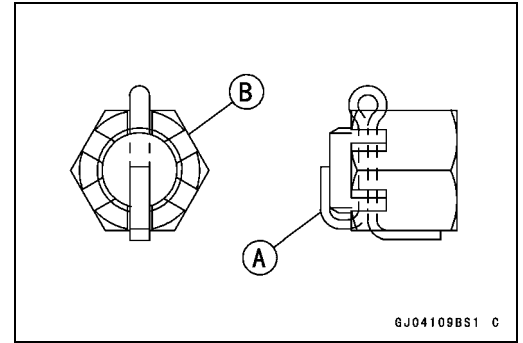

#### *Front Suspension Arm Inspection*

- Visually inspect the front suspension arm for breaks or distortion.
- ★ If the front suspension arm is damaged in any way, replace it.
- Check the rubber bushings in the pivots.
- ★ Replace any bushings that are worn, cracked, hardened, or otherwise damaged.

## 14-12 SUSPENSION

### Leaf Springs and Dampers

#### Leaf Spring Removal

- Remove:
  - Rear Wheel (see Wheels/Tires chapter)
- Hold the rear brake drum and panel assembly in position.
- Free the brake hose [A], pipe, and cable from the leaf spring.
- Immediately wipe up any brake fluid that spills.

#### CAUTION

**Brake fluid quickly ruins painted surfaces; any spilled fluid should be completely wiped up immediately.**

- Remove:
  - Rear Shock Absorber [B]
  - Damper Bracket Mounting Nuts [C]
  - Damper and Bracket [D]
- Remove:
  - Clamp [A]
  - Leaf Spring Mounting Bolts and Nuts [B]
  - Leaf Spring [C]

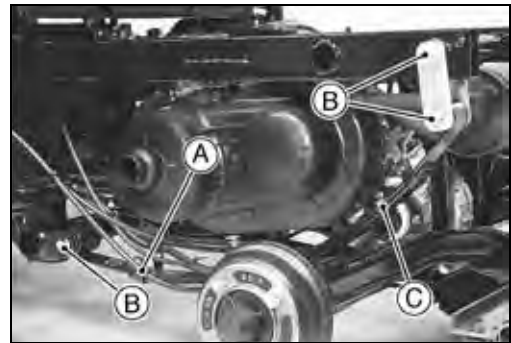
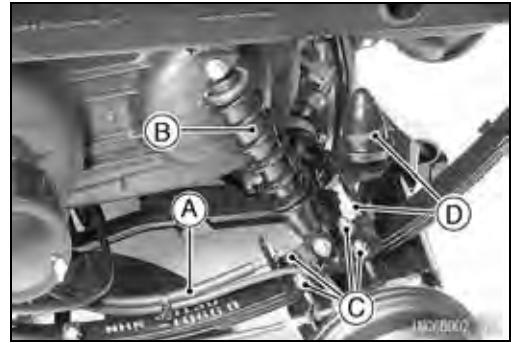

#### Leaf Spring Installation

- When installing the rubber bushings to the leaf spring, lubricate them with a soap and water solution.

#### CAUTION

**Do not use engine oil or petroleum distillates to lubricate the bushings because they will deteriorate the rubber.**

- Tighten:
  - Torque - Damper Bracket Mounting Nuts: 44 N·m (4.5 kgf·m, 33 ft·lb)**
  - Brake Pipe Nipple: 18 N·m (1.8 kgf·m, 13 ft·lb)**
- Install the rear wheel temporarily and ground it to load the suspension during the mounting nut tightening.
- Tighten:
  - Torque - Leaf Spring Mounting Nuts (front): 98 N·m (10 kgf·m, 72 ft·lb)**
  - Leaf Spring Mounting Nuts (rear): 59 N·m (6.0 kgf·m, 43 ft·lb)**
  - Rear Shock Absorber Mounting Nuts: 59 N·m (6.0 kgf·m, 43 ft·lb)**
- Bleed the brake line (see Brakes chapter).

---

## Leaf Springs and Dampers

---

### *Leaf Spring Inspection*

- Visually inspect the leaf spring for breaks or distortion.
- ★ If the leaf spring is damaged in any way, replace it.
- Check the rubber bushings in the mounts and the damper.
- ★ Replace any bushings or damper that are worn, cracked, hardened, or otherwise damaged.



---

# Steering

## Table of Contents

Exploded View.....	15-2
Specifications .....	15-4
Steering Wheel and Main Shaft Assembly .....	15-5
Steering Wheel Position Adjustment.....	15-5
Steering Wheel Free Play Inspection.....	15-5
Steering Wheel Centering.....	15-5
Steering Wheel and Steering Shaft Removal .....	15-5
Steering Wheel and Main Shaft Installation .....	15-6
Steering Gear Assembly.....	15-7
Steering Gear Assembly Removal.....	15-7
Steering Gear Assembly Installation.....	15-7
Steering Gear Preload Adjustment .....	15-8
Tie-rod Length Adjustment.....	15-9
Steering Joint Dust Boot Inspection.....	15-9
Steering Knuckles.....	15-10
Steering Knuckle Removal.....	15-10
Steering Knuckle Installation.....	15-10

# 15-2 STEERING

## Exploded View

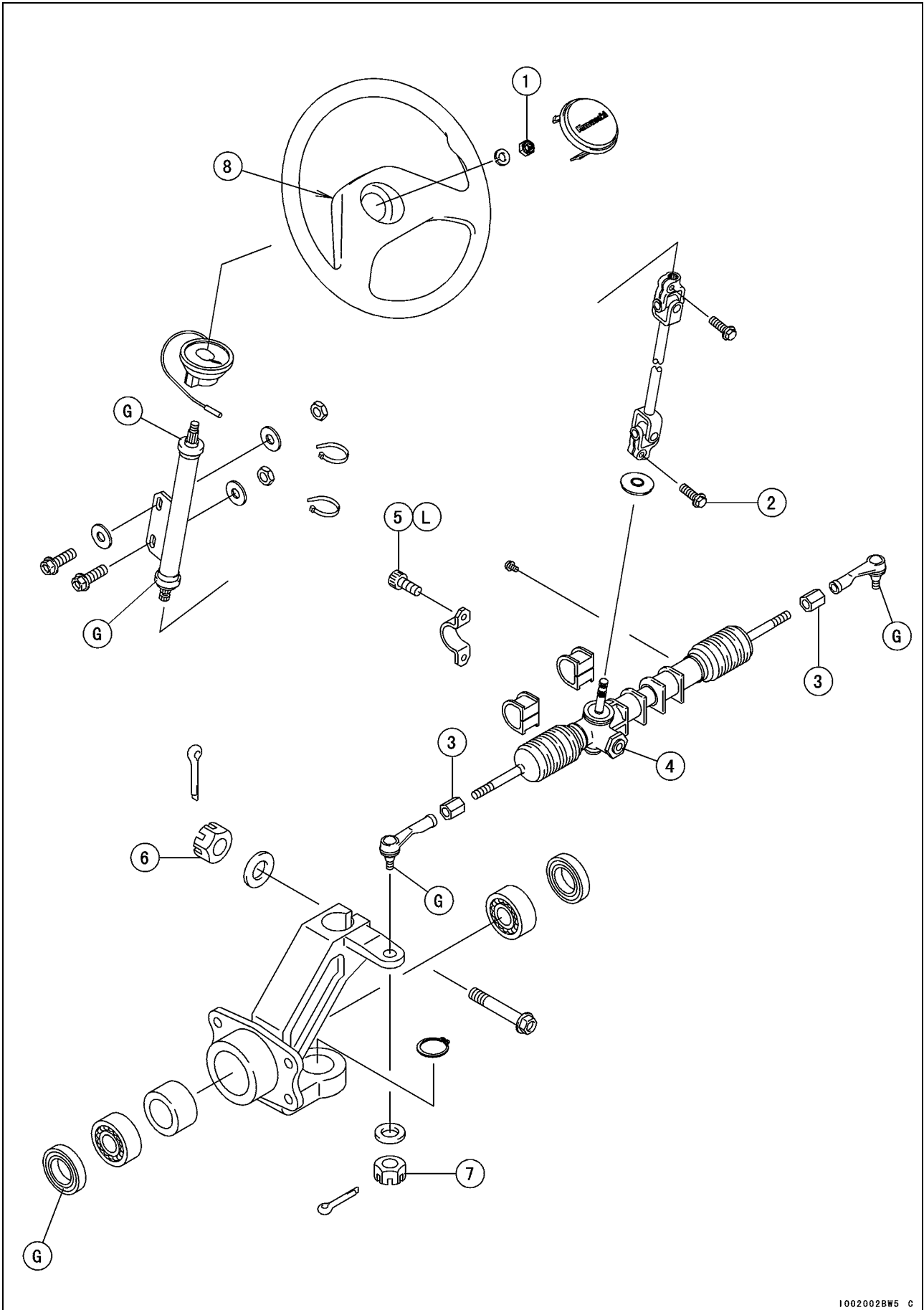

1002002BW5 C



**Exploded View**

No.	Fastener	Torque			Remarks
		N-m	kgf-m	ft-lb	
1	Steering Wheel Mounting Nut	52	5.3	38	
2	Intermediate Shaft Clamp Bolts	20	2.0	14	
3	Tie-rod End Locknuts	49	5.0	36	
4	Rack Guide Spring Cap Locknut	39	4.0	29	
5	Steering Gear Assembly Bracket Bolts	52	5.3	38	L
6	Strut Clamp Nut	98	10	72	
7	Tie-rod End Nuts	34	3.5	25	

8. Apply grease on contact plate.

G: Apply grease.

L: Apply a non-permanent locking agent.

## 15-4 STEERING

### Specifications

Item	Standard	Service Limit
<b>Steering Wheel</b> Steering wheel free play	0 ~ 20 mm (0 ~ 0.79 in.)	— — —
<b>Steering Gear Assembly</b> Tie-rod length (distance between boot end and locknut)	43.5 mm (1.71 in.)	— — —

## Steering Wheel and Main Shaft Assembly

### Steering Wheel Position Adjustment

- Loosen the steering main shaft bracket mounting nuts [A].
- Adjust the steering wheel position.
- Tighten the main shaft bracket mounting nuts securely.



### Steering Wheel Free Play Inspection

- Refer to Steering Wheel Free Play Inspection in the Periodic Maintenance chapter.

### Steering Wheel Centering

- Test ride the vehicle.
- ★ If the steering wheel is not straight when the vehicle is traveling in a straight line, do the following.
  - Check the tie-rod length and adjust it if necessary.
  - Remove the cap and loosen the steering wheel mounting nut [A].
  - Push the vehicle in a straight line with no one aboard, and stop it without turning the steering wheel.
  - Remount the steering wheel so that it is straight ahead.



**Torque - Steering Wheel Mounting Nut: 52 N·m (5.3 kgf·m, 38 ft·lb)**

### Steering Wheel and Steering Shaft Removal

- Remove:
  - Wheel Cap [A]
  - Steering Wheel Mounting Nut [B] and Spring Washer
  - Steering Wheel [C]

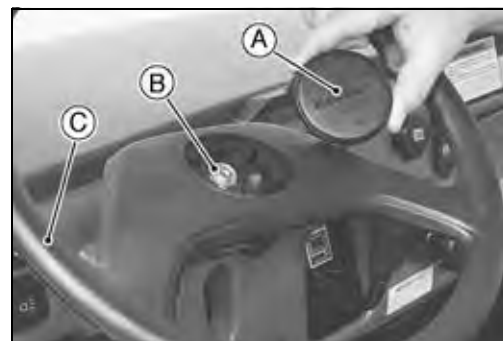

- Remove:
  - Horn Switch
  - Main Shaft Mounting Bolts, Washers and Nuts [A]
  - Main Shaft Clamp Bolt [B]
  - Main Shaft [C]

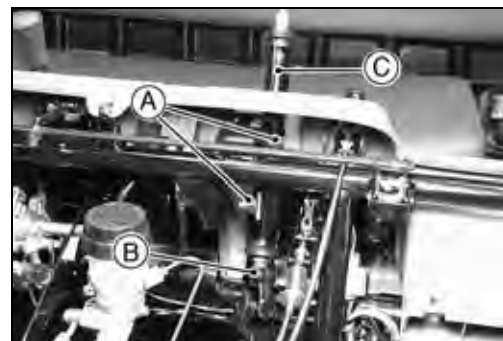

## 15-6 STEERING

### Steering Wheel and Main Shaft Assembly

- Remove:
  - Steering Gear Shaft Clamp Bolt [A]
  - Intermediate Shaft [B]

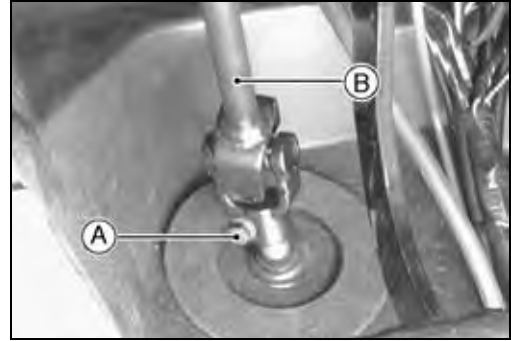

#### *Steering Wheel and Main Shaft Installation*

- Grease:
  - Dust Cover Lips [A]

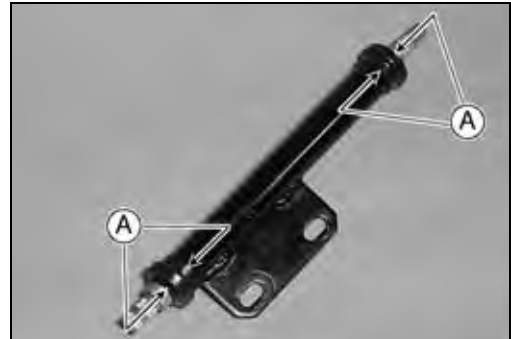

- Connect the intermediate shaft [A] to the main shaft and the steering gear pinion in any position. Mount the steering wheel on the main shaft temporarily.
- Adjust:
  - Steering Wheel Position Adjustment
  - Steering Wheel Centering
- Tighten:
  - Torque - Intermediate Shaft Clamp Bolts [B]: 20 N·m (2.0 kgf·m, 14 ft·lb)**

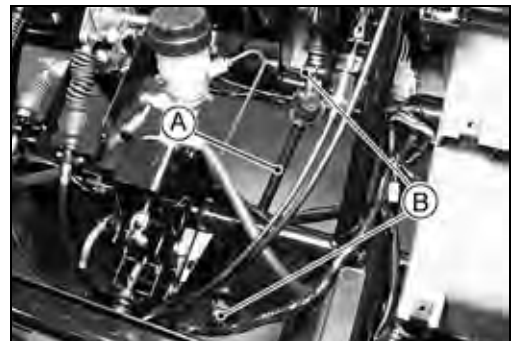

## Steering Gear Assembly

### Steering Gear Assembly Removal

- Remove:
  - Front Fender Upper (see Frame chapter)
  - Steering Wheel and Main Shaft Assembly
  - Front Radiator (see Cooling System chapter)
  - Tie-rod End Nuts [A]
  - Tie-rod Ends [B] from Steering Knuckles
- Install a suitable nut on the stud of the tie-rod end joint and tap the nut to free the joint from the steering knuckle.



**CAUTION**

**Do not loosen the tie-rod end locknuts [C], or the toe-in of the front wheels will be changed.**

- Remove:
  - Radiator Side Cover (Left) [A]
  - Coolant Hose [B]
  - Coolant Pipe (Front) [C]
  - Boot [D]
  - Steering Gear Assembly Bracket Bolts [E] and Brackets

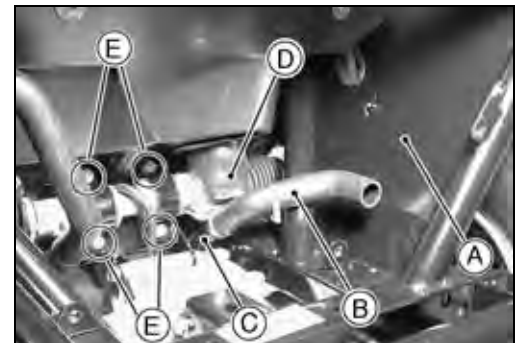

- Remove:
  - Steering Gear Assembly [A]



### Steering Gear Assembly Installation

- Adjust if necessary:
  - Steering Gear Preload Adjustment
  - Tie-rod Length Adjustment
- Clean the tapered portion of the tie-rod end joint and the tapered hole of the steering knuckle, or the tapers will not fit snugly.
- Grease:
  - Tie-rod End Joint Boot Sealing Surfaces [A]

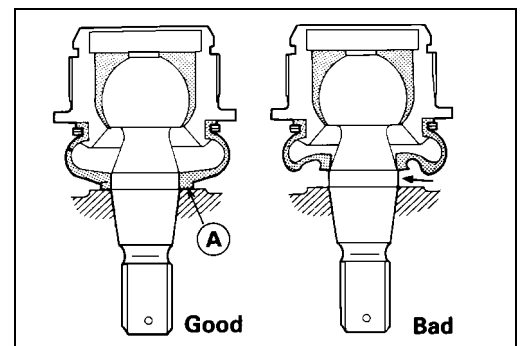

## 15-8 STEERING

### Steering Gear Assembly

- Install the boot [A] so that the mark (F, Arrow) [B] faces forward.
- Tighten:
  - Torque - Steering Gear Assembly Bracket Bolts: 52 N·m (5.3 kgf·m, 38 ft·lb)
  - Tie-rod End Nuts: 34 N·m (3.5 kgf·m, 25 ft·lb)

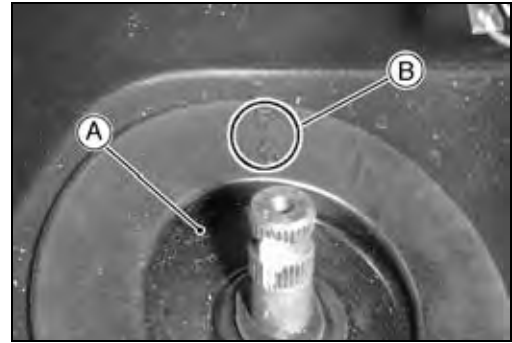

- Insert a new cotter pin [A].

#### NOTE

- When inserting the cotter pin, if the slots in the nut do not align with the cotter pin hole in the axle, tighten the nut clockwise [B] up to next alignment.
- It should be within 30 degree.
- Loosen once and tighten again when the slot goes past the nearest hole.

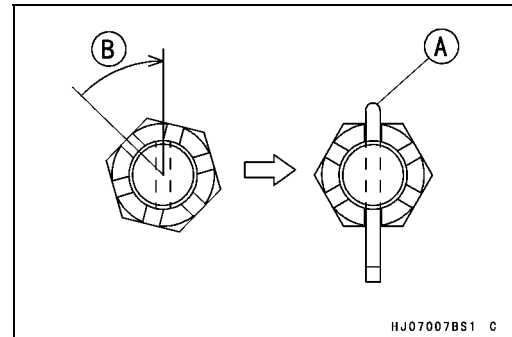

- Bend the cotter pin [A] over the nut [B].
- Check:
  - Toe-in of Front Wheels (see Wheels/Tires chapter)

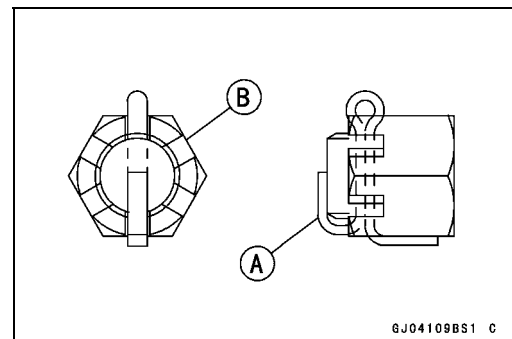

#### Steering Gear Preload Adjustment

- Loosen the locknut [A].
- Tighten the rack guide spring cap [B] to 6.9 N·m (0.70 kgf·m, 61 in·lb) of torque.
- Back off the cap 60 ~ 70°.
- Tighten the locknut while preventing the cap from turning.

Torque - Rack Guide Spring Cap Locknut: 39 N·m (4.0 kgf·m, 29 ft·lb)

- Pinion [C]
- Rack [D]
- Rack Guide [E]
- Spring [F]

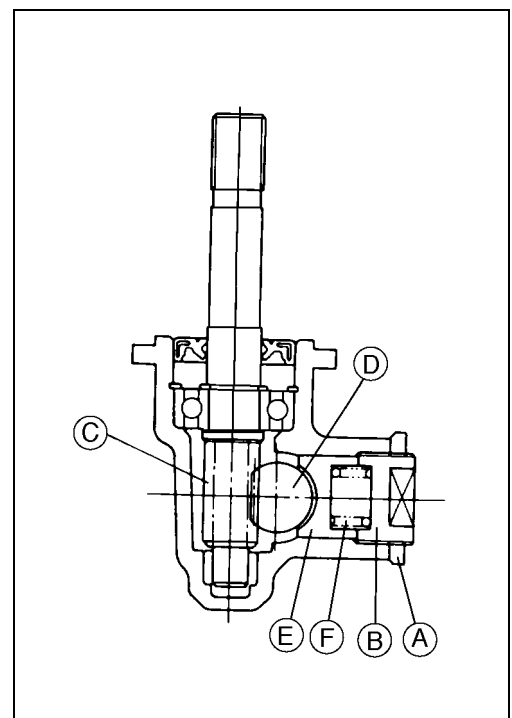

## Steering Gear Assembly

### *Tie-rod Length Adjustment*

- Check the length [A] of the tie-rod distance between the dust boot end [B] of steering gear assembly and the locknut [C]. This distance should be the specified value for both the left and right tie-rods.

**Tie-rod Length (distance between boot end and locknut)**

**Standard: 43.5 mm (1.71 in.)**

- ★ If it is not, adjust the tie-rod length.
- Loosen the locknut and turn the adjusting rod [D] to achieve the specified value.
- Tighten:

**Torque - Tie-rod End Locknuts: 49 N·m (5.0 kgf·m, 36 ft·lb)**

### *Steering Joint Dust Boot Inspection*

- Refer to Steering Joint Dust Boot Inspection in the Periodic Maintenance chapter.

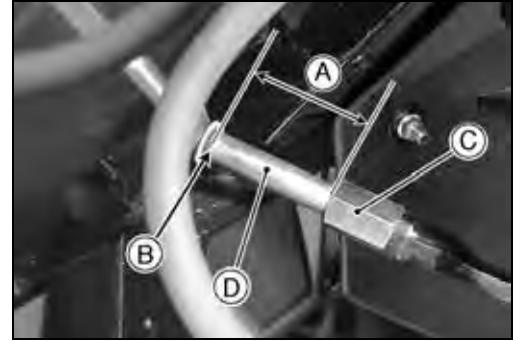

## 15-10 STEERING

### Steering Knuckles

#### Steering Knuckle Removal

- Remove:
  - Front Wheel (see Wheels/Tires chapter)
  - Front Brake Drum (see Brakes chapter)
  - Front Brake Panel Assembly (see Brakes chapter)
  - Tie-rod End Nut [A]
  - Tie-rod End [B] from Steering Knuckle
- Install a suitable nut on the stud of the tie-rod end joint and tap the nut to free the joint from the steering knuckle.

#### CAUTION

**Do not loosen the tie-rod end locknuts [C], or the toe-in of the front wheels will be changed.**

- Remove:
  - Brake Hose Clamp [D]
  - Strut Clamp Bolt and Nut [E]
- Remove:
  - Front Suspension Arm Joint Nut [A]
- Install a suitable nut on the stud of the joint and tap the nut to free the joint from the steering knuckle.
- Remove:
  - Steering Knuckle [B]

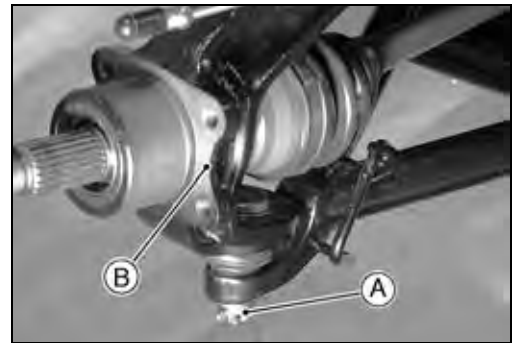
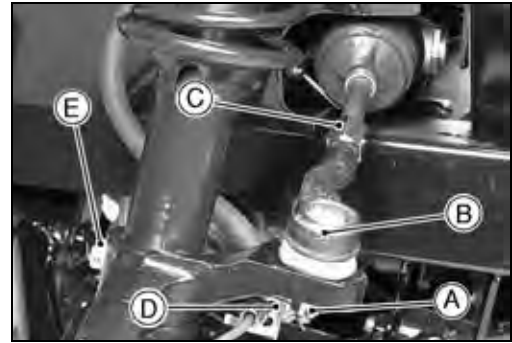

#### Steering Knuckle Installation

- Clean the tapered portions of the front suspension arm joint and the tie-rod end joint and the tapered holes of the steering knuckle and the front suspension arm, or the tapers will not fit snugly.
- Grease:
  - Axle Bearing Grease Seal Lips
  - Front Suspension Arm Joint Boot Sealing Surfaces [A]
- Tighten:
  - Torque - Strut Clamp Nut: 98 N·m (10 kgf·m, 72 ft·lb)
  - Front Suspension Arm Joint Nut: 78 N·m (8.0 kgf·m, 58 ft·lb)
  - Tie-rod End Nut: 34 N·m (3.5 kgf·m, 25 ft·lb)
- Insert a new cotter pin [A].

#### NOTE

- When inserting the cotter pin, if the slots in the nut do not align with the cotter pin hole in the axle, tighten the nut clockwise [B] up to next alignment.
- It should be within 30 degree.
- Loosen once and tighten again when the slot goes past the nearest hole.

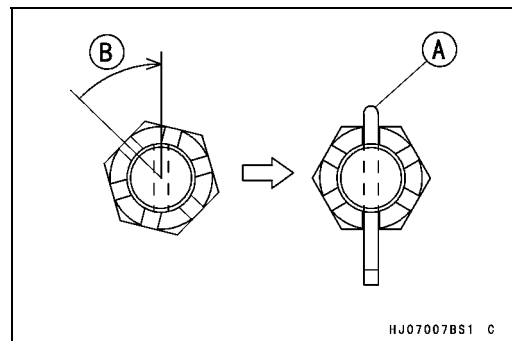
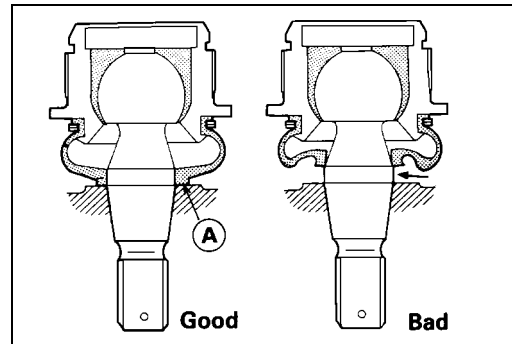

HJ07007BS1 C



**Steering Knuckles**

- Bend the cotter pin [A] over the nut [B].
- Check:  
Toe-in of Front Wheels (see Wheels/Tires chapter)

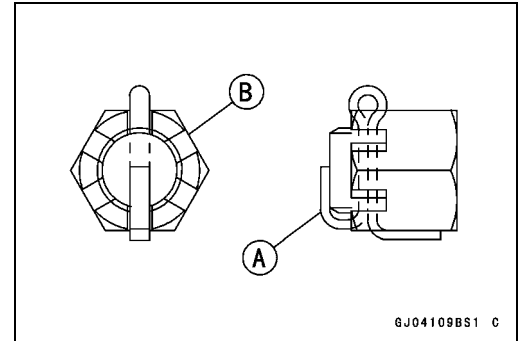



# Frame

## Table of Contents

Exploded View.....	16-2
Seat and Seat Belts.....	16-8
Front Seat Removal.....	16-8
Front Seat Installation.....	16-8
Rear Seat Removal.....	16-9
Rear Seat Installation.....	16-10
Seat Belt Removal.....	16-10
Seat Belt Installation.....	16-11
Control Panel.....	16-12
Control Panel Removal.....	16-12
Glove Compartment Removal.....	16-12
Front Cargo Compartment.....	16-13
Front Cargo Hood Removal.....	16-13
Front Cargo Compartment Removal.....	16-13
Cargo Bed.....	16-14
Cargo Bed Removal.....	16-14
Cargo Bed Installation.....	16-15
Front, Center and Rear Bars.....	16-16
Front Bar Removal.....	16-16
Front Bar Installation.....	16-16
Rear Bar Removal.....	16-16
Rear Bar Installation.....	16-17
Center Bar Removal.....	16-17
Center Bar Installation.....	16-17
Cargo Bed Latch Position Inspection.....	16-18
Cargo Bed Latch Position Adjustment.....	16-18
Front Fender Assembly.....	16-19
Front Cover Removal.....	16-19
Front Fender Removal.....	16-20
Radiator Side Cover Removal.....	16-20
Radiator Side Cover Installation.....	16-21
Radiator Side Cover Flap Removal.....	16-21
Floor Center Panel Removal.....	16-21
Rear End Sub-frame.....	16-23
Rear End Sub-frame Removal.....	16-23
Rear End Sub-frame Installation.....	16-23

# 16-2 FRAME

## Exploded View

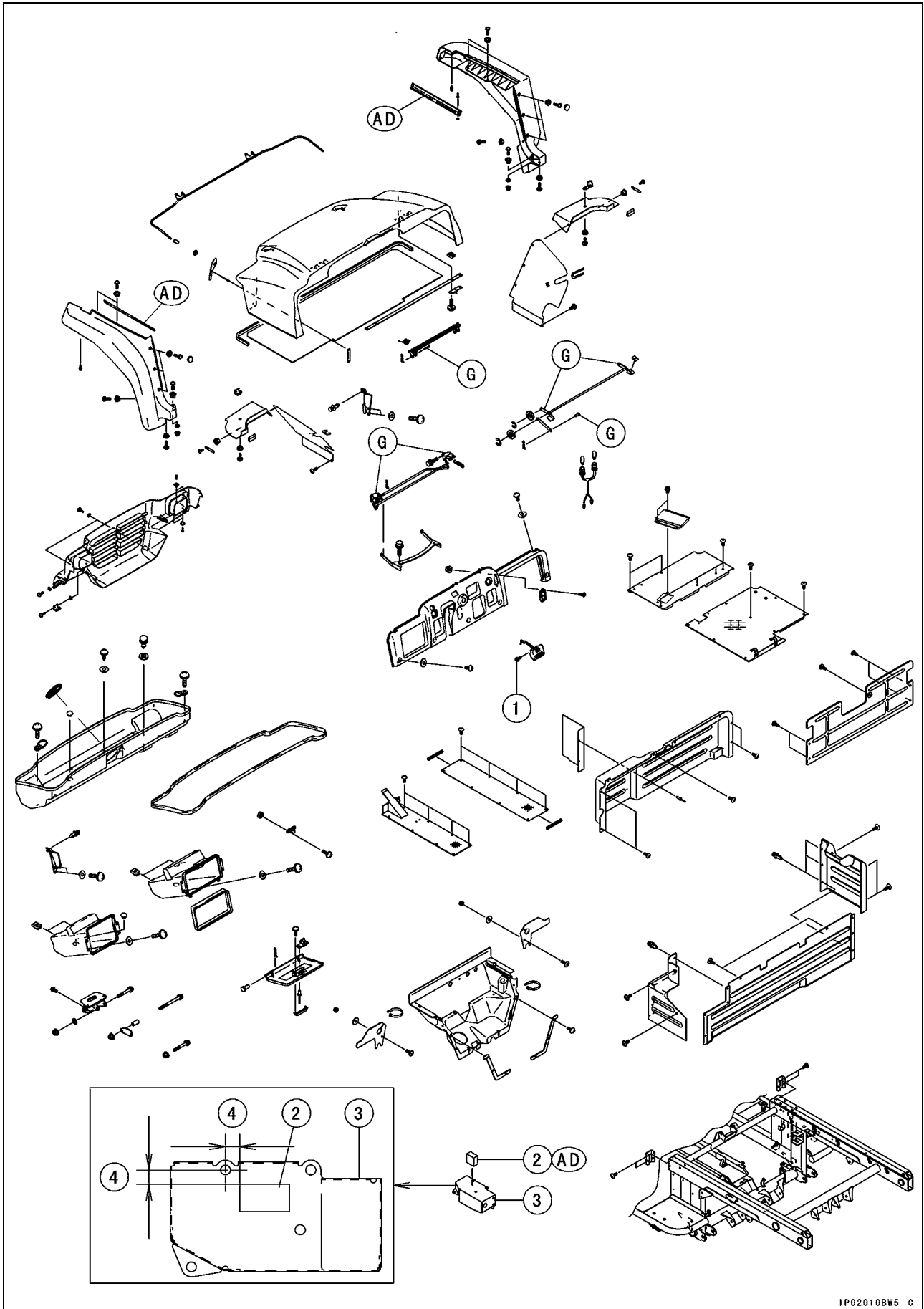

IP02010BW5 C

**Exploded View**

No.	Fastener	Torque			Remarks
		N·m	kgf·m	ft·lb	
1	Hood Latch Lever Mounting Bolt	39	4.0	29	

- 2. Damper
  - 3. Carburetor Cover
  - 4. 10 mm (0.39 in.)
- AD: Apply adhesive agent.  
 G: Apply grease.

# 16-4 FRAME

## Exploded View

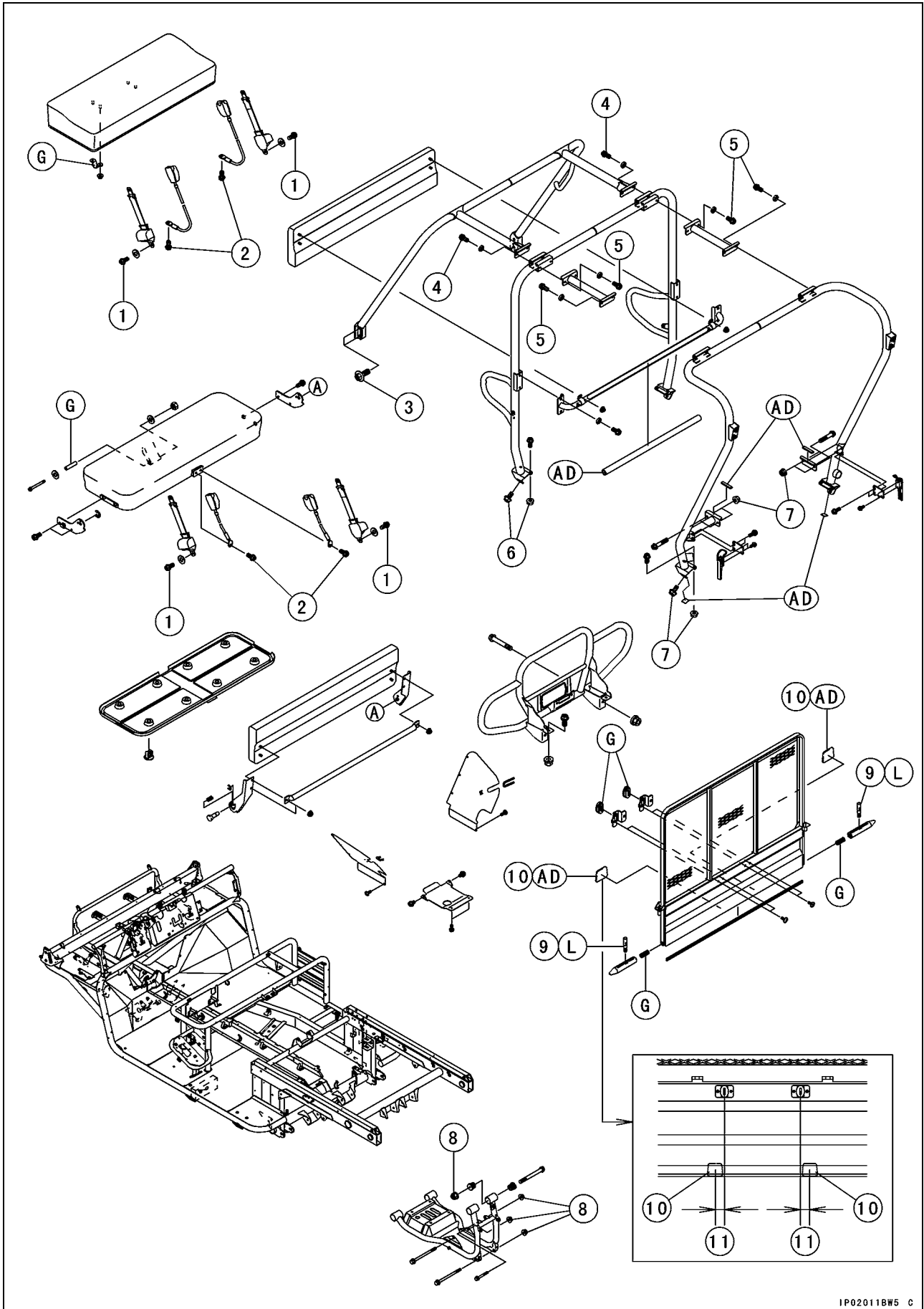

IP02011BW5 C

**Exploded View**

No.	Fastener	Torque			Remarks
		N·m	kgf·m	ft·lb	
1	Seat Belt Mounting Bolts	34	3.5	25	
2	Seat Belt Buckle Mounting Bolts	34	3.5	25	
3	Front Bar Mounting Bolts (Lower)	98	10	72	
4	Front Bar Mounting Bolts (Upper)	44	4.5	33	
5	Top Bar Mounting Bolts	44	4.5	33	
6	Center Bar Mounting Bolts and Nuts	44	4.5	33	
7	Rear Bar Mounting Bolts and Nuts	44	4.5	33	
8	Rear End Sub-frame Mounting Bolts	44	4.5	33	
9	Screen Fixing Lever Screw	4.4	0.45	39 in·lb	L

10. Dampers

11. 18 mm (0.71 in.)

AD: Apply adhesive agent.

G: Apply grease.

L: Apply a non-permanent locking agent.

# 16-6 FRAME

## Exploded View

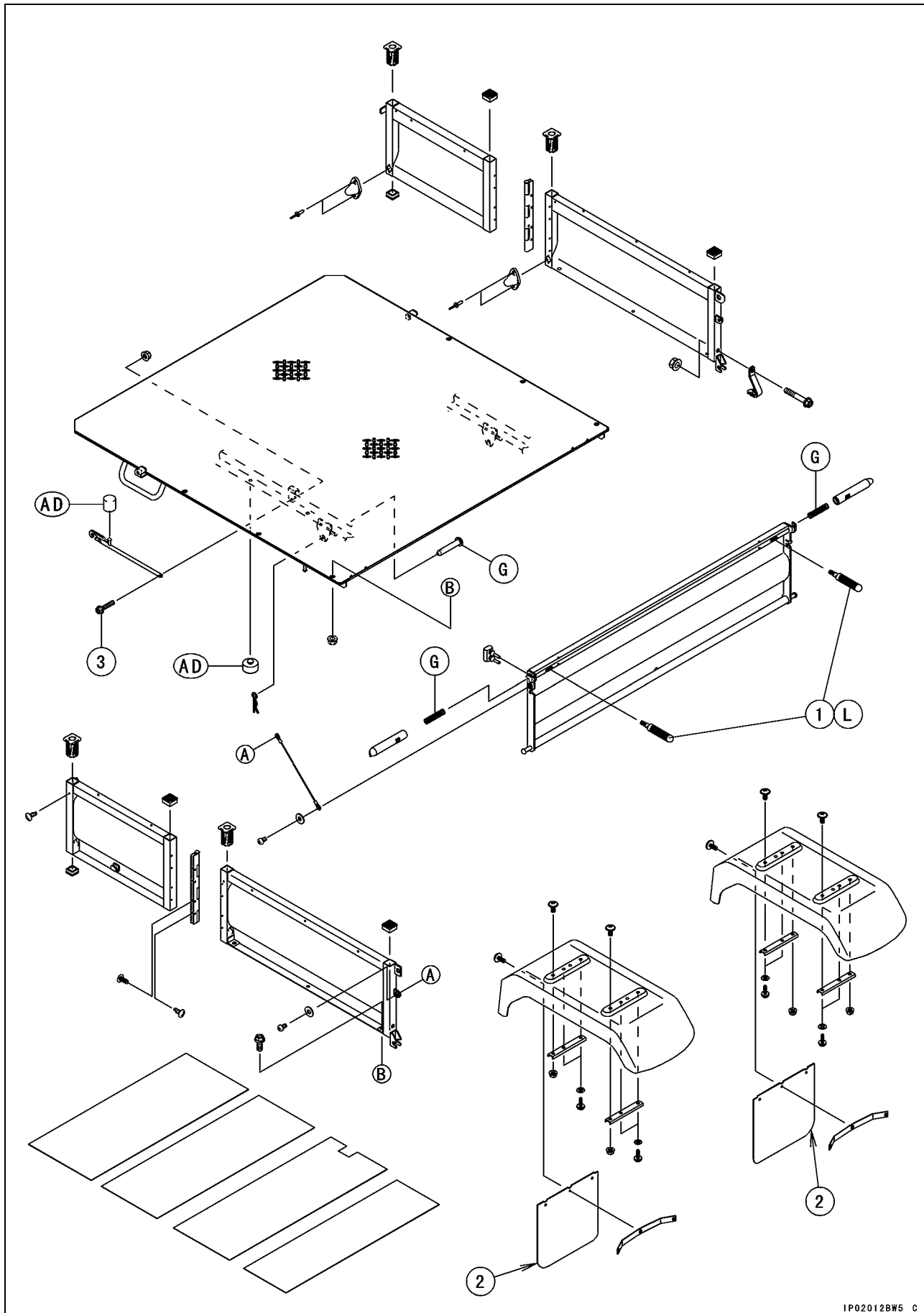

IP02012BW5 C



**Exploded View**

No.	Fastener	Torque			Remarks
		N·m	kgf·m	ft·lb	
1	Tail Gate Fixing Lever Screw	4.4	0.45	39 in·lb	L

- 2. Large Corner Side
  - 3. Fix the bolt to inside from outside.
- AD: Apply adhesive agent.  
G: Apply grease.  
L: Apply a non-permanent locking agent.

## 16-8 FRAME

### Seat and Seat Belts

#### Front Seat Removal

- Remove:
  - Seat Bracket Nuts [A]
  - Seat Brackets [B]
  - Seat [C]

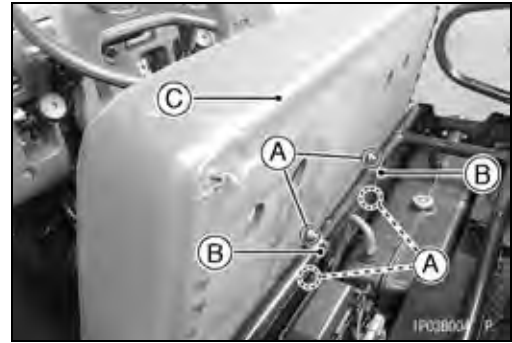

- Remove:
  - Seat Back Mounting Nuts [A]
  - Seat Back [B]

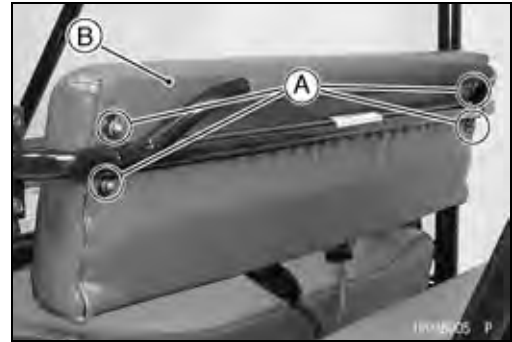

#### Front Seat Installation

- Grease:
  - Seat Bracket Inside Surfaces [A]
- Be careful not to overtighten the seat bracket nuts. After tightening the nuts, the seat must be moved up and down smoothly.

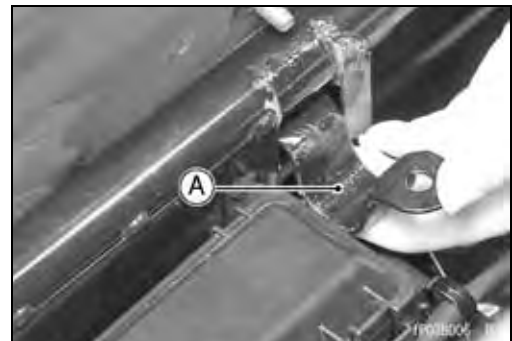

- Install the front seat back [A] so that its thicker side [B] faces downward.

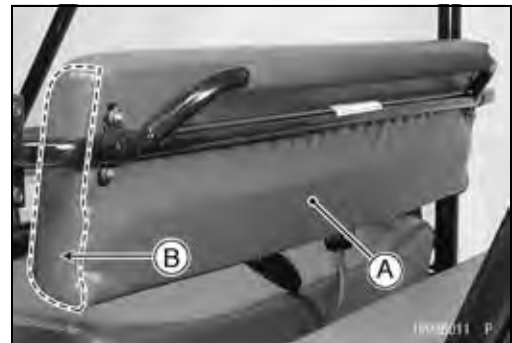

- When replacing the rear handle pad [A], install it on the seat bar [B] with adhesive agent as shown.
  - [C] Slit
  - [D] Adhesive Agent, Length: 800 ~ 820 mm (31.50 ~ 32.28 in.)

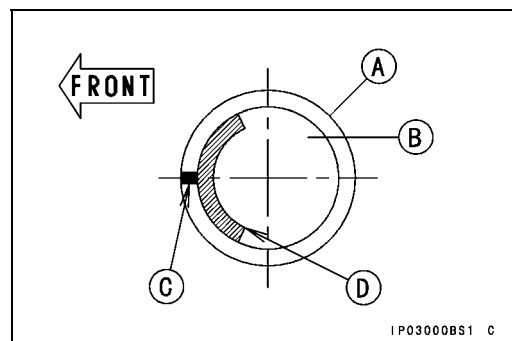

## Seat and Seat Belts

### Rear Seat Removal

- Fold the rear seat and push its assembly into the stored position.
- Tilt up the cargo bed.
- Remove the pivot bolt [A] and nut [B].
- Remove the rear seat [C].

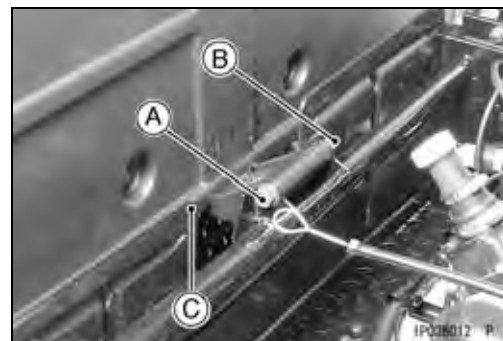

- Remove:  
Rear Seat Back Mounting Nuts [A]  
Rear Seat Stay [B]  
Rear Seat Back [C]

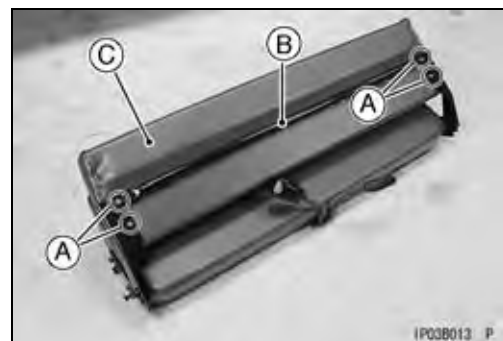

- Remove:  
Bottom Lever Bolts [A]  
Bottom Lever [B] with Upper Lever [C]

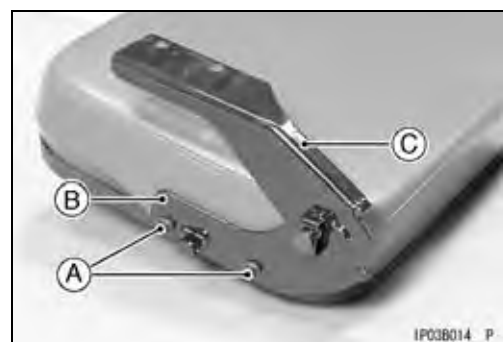

- Remove:  
Circlip [A]



- Remove:  
Circlip [A] (Left Side only)  
Spring [B] and Pin [C] (Left Side only)
- Separate the upper lever from the bottom lever.

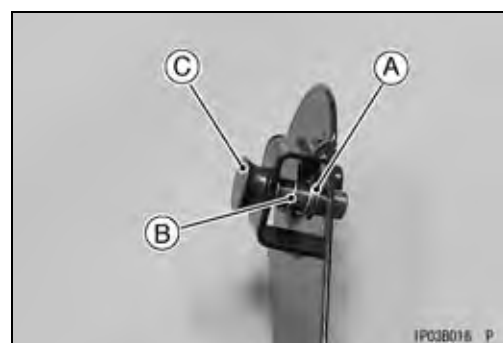

## 16-10 FRAME

### Seat and Seat Belts

#### Rear Seat Installation

- Install the rear seat back [A] so that its thicker side [B] faces upward.

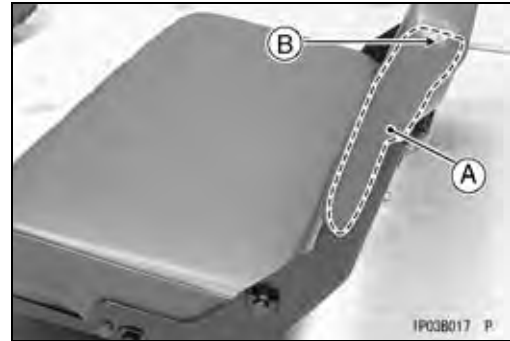

#### Seat Belt Removal

- Remove:
  - Front Seat Belt Mounting Bolts [A]
  - Front Seat Belts [B]

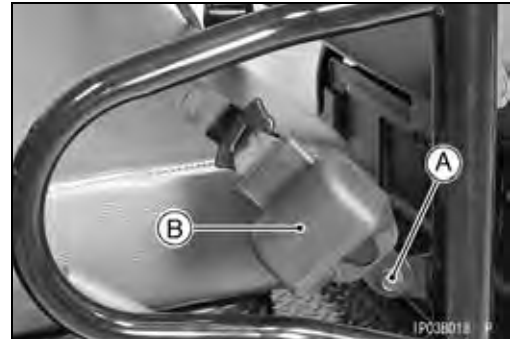

- Remove:
  - Front Seat Belt Buckle Mounting Bolts [A]
  - Front Seat Belt Buckles [B]

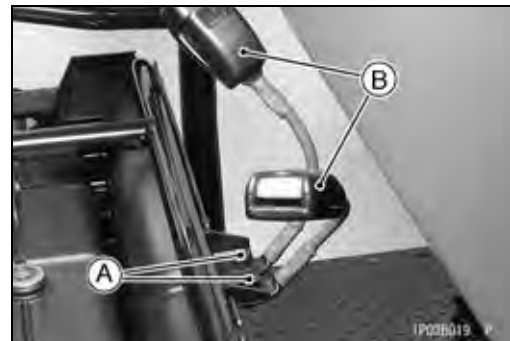

- Remove:
  - Rear Seat Belt Mounting Bolts [A]
  - Rear Seat Belts [B]



- Remove:
  - Rear Seat Belt Buckle Mounting Bolts [A]
  - Rear Seat Belt Buckles [B]



## Seat and Seat Belts

### Seat Belt Installation

- Tighten:

**Torque - Seat Belt Mounting Bolts: 34 N·m (3.5 kgf·m, 25 ft·lb)**

○ Install the front [A] and rear seat belts so that their installation angle is  $40^{\circ} \sim 60^{\circ}$  [B].

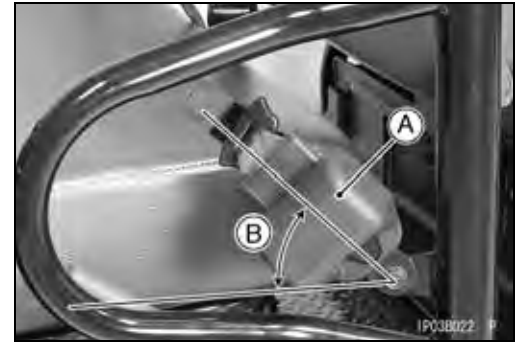

- Tighten:

**Torque - Seat Belt Buckle Mounting Bolts: 34 N·m (3.5 kgf·m, 25 ft·lb)**

○ Install the front [A] and rear seat belt buckles so that their red buttons [B] face inside.

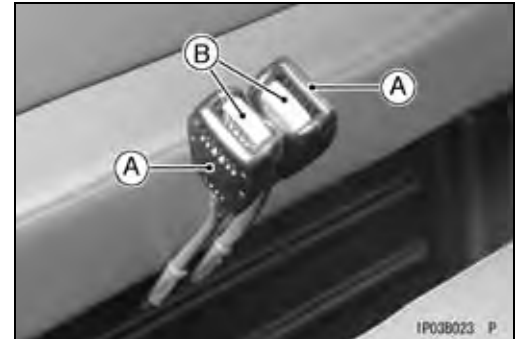

## 16-12 FRAME

### Control Panel

#### Control Panel Removal

- Remove:
  - Front Cargo Compartment (see Front Cargo Compartment Removal)
- Disconnect:
  - Light Switch Wire Connector
  - Hour Meter Wire Connector
  - Ignition Switch Wire Connector
  - Power Outlet Connector Wire Connector
  - Coolant Temperature Warning/Parking Brake Indicator
  - Light Wire Connector
- Remove:
  - Control Panel Lower Screws [A] and Collars
- Loosen:
  - Control Panel Upper Screws [B]
- Open the right glove compartment cover [C]
- Remove:
  - Control Panel [D]

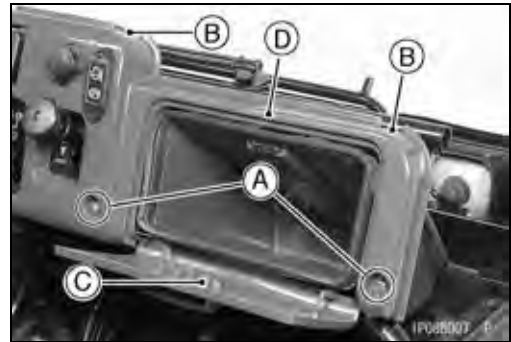
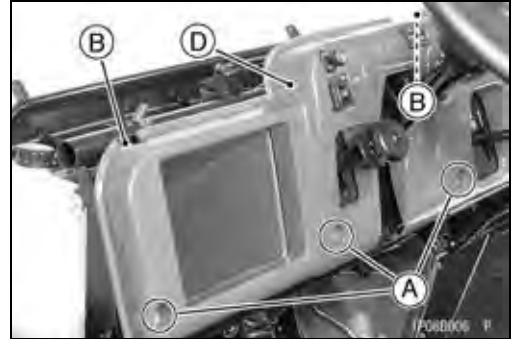

#### Glove Compartment Removal

- Remove:
  - Control Panel (see Control Panel Removal)
  - Screws [A]
  - Left Glove Compartment [B]
  - Right Glove Compartment [C]

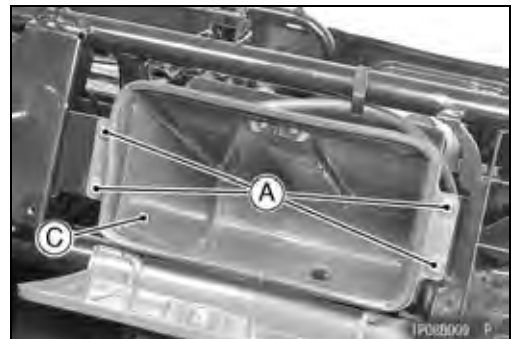
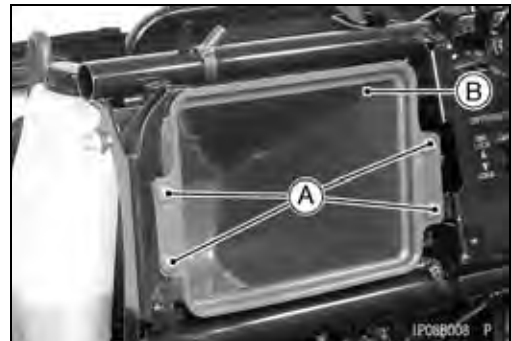

## Front Cargo Compartment

### Front Cargo Hood Removal

- Remove:
  - Rear Snap Pins [A]
  - Mounting Pins [B]
  - Front Snap Pins [C]
- Slide the front cargo hood [D] to the right and remove it.

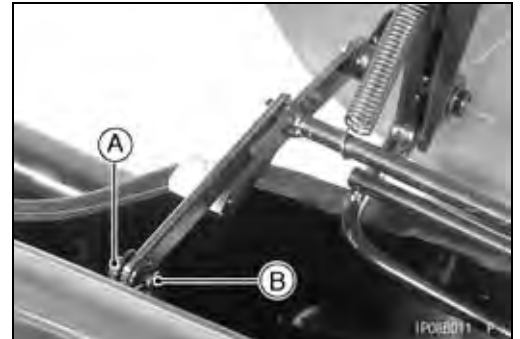
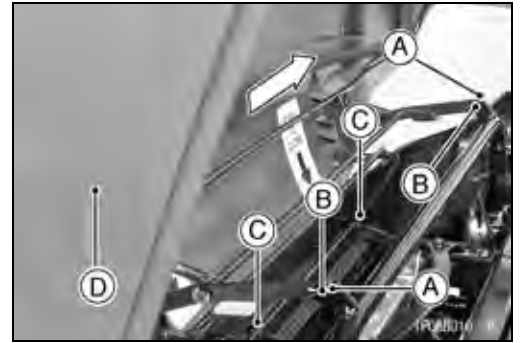

- Remove:
  - Arm Assembly Bolts [A]
  - Arm Assembly [B]
  - Stay

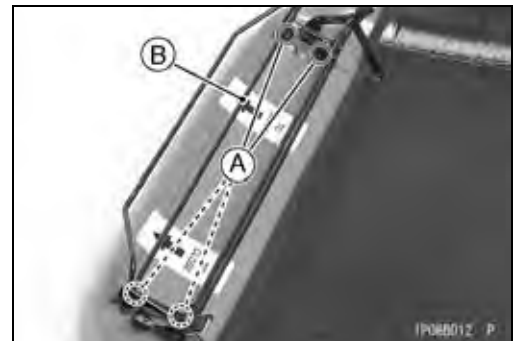

### Front Cargo Compartment Removal

- Remove:
  - Front Cargo Hood (see Front Cargo Hood Removal)
  - Mounting Rivets [A]
  - Screws and Hooks [B]
  - Screws [C]
  - Front Cargo Compartment [D]

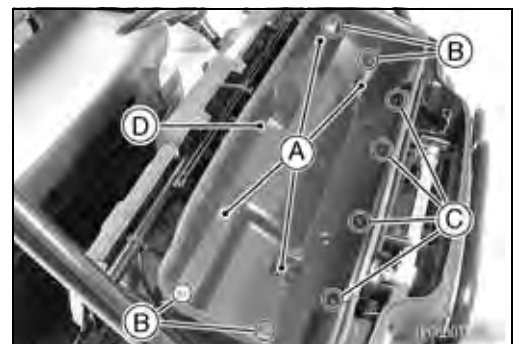

## 16-14 FRAME

### Cargo Bed

#### *Cargo Bed Removal*

- Unlock the hooks [A]
- Raise the rear seat and push it toward the front seat back to store.



- Remove:
  - Rear Fenders Mounting Screws [A]
  - Rear Fenders [B]

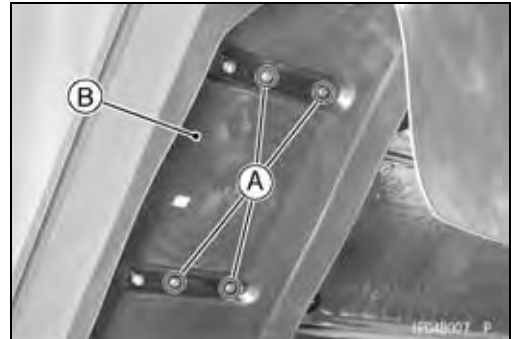

- Remove:
  - Tail/Brake Light Wires [A]
  - Tail/Brake Light Mounting Bolts [B]
  - Tail/Brake Light Assemblies [C]

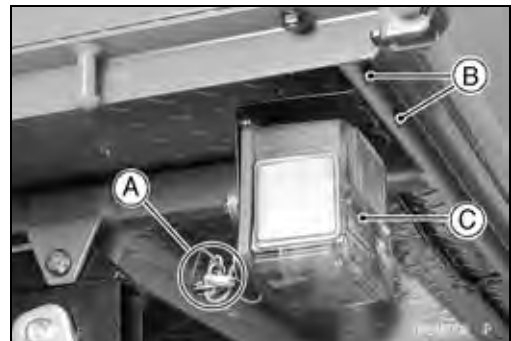

- Remove:
  - Snap Pins [A]
  - Cargo Bed Mounting Pins [B]
  - Cargo Bed [C]

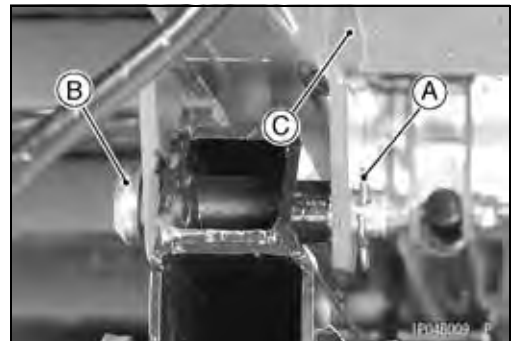



## Cargo Bed

### Cargo Bed Installation

- Grease:
  - Cargo Bed Mounting Pins
- Apply adhesive agent:
  - Cargo Bed Rubber Dampers (Bottom) [A]
  - Frame Rubber Dampers (Upper) [B]
  - Tail Gate Pivot Rubber Dampers (Left and Right)

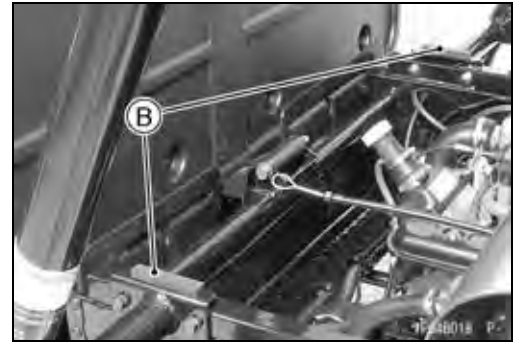
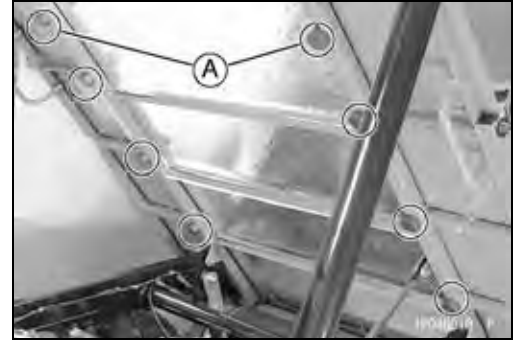

- When the cargo bed is disassembled, note the following when installing the plates and tail gate.
  - Be sure the clearance [A] between the back end of the carrier [B] and the bottom of the tail gate [C] is more than 2 mm (0.0787 in.) as shown (Left and Right).

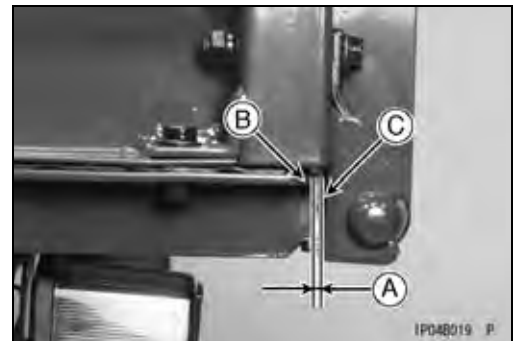

- Be sure the clearance [A] between the plate end [B] and the tail gate end [C] is less than 5 mm (0.197 in.) as shown (Left and Right).

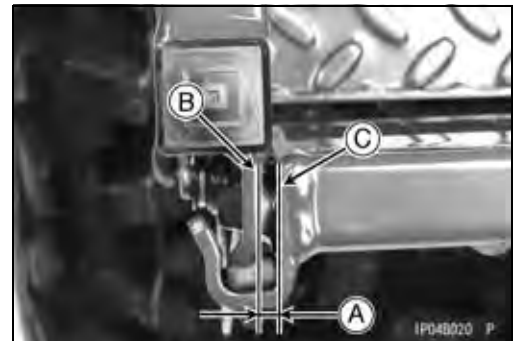

## 16-16 FRAME

### Front, Center and Rear Bars

#### Front Bar Removal

- Remove:
  - Front Bar Mounting Bolts [A]
  - Front Bar [B]



#### Front Bar Installation

- Tighten:
  - Torque - Front Bar Mounting Bolts (Lower): 98 N·m (10 kgf·m, 72 ft·lb)
  - Front Bar Mounting Bolts (Upper): 44 N·m (4.5 kgf·m, 33 ft·lb)

#### Rear Bar Removal

- Remove:
  - Rear Bar Mounting Bolts (Upper) [A]
  
- Remove:
  - Air Duct Clamp [A] (loosen) and Air Duct
  - Rear Bar Mounting Bolts [B]
  
- Remove:
  - Air Duct Clamp [A] (loosen) and Air Duct
  - Rear Bar Mounting Bolts [B]
  - Rear Bar [C]

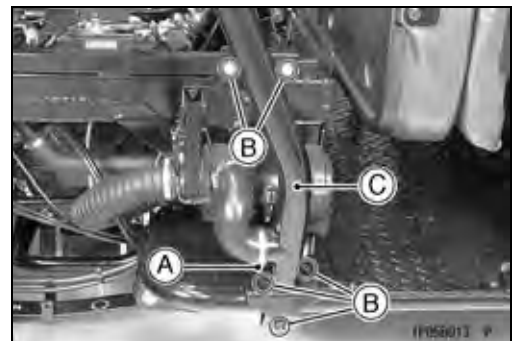
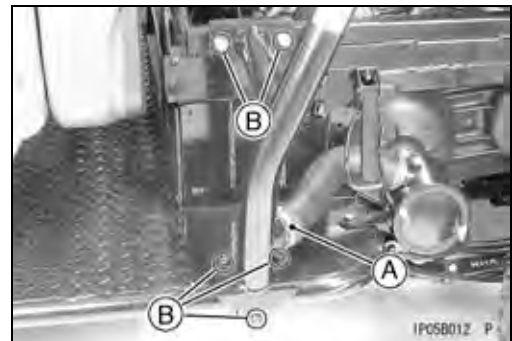

**Front, Center and Rear Bars**

*Rear Bar Installation*

- Be sure the rubber plates [A] are in position.
- Plug one hole [B] and plug only half about another hole [C], using the rubber plate.
- Tighten:
  - Torque - Rear Bar Mounting Bolts and Nuts: 44 N·m (4.5 kgf·m, 33 ft·lb)**

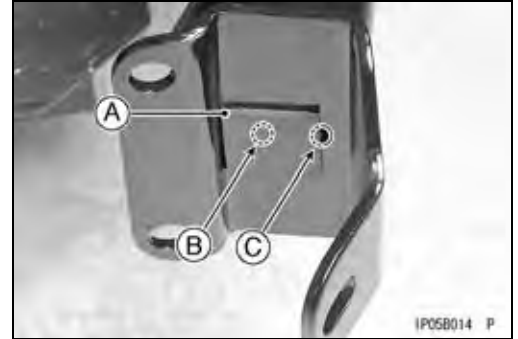

*Center Bar Removal*

- Remove:
  - Rear Bar (see this chapter)
  - Top Bar Mounting Bolts [A]
  - Top Bars [B]
  - Seat Bar Mounting Bolts [C]
  - Seat Bar [D]

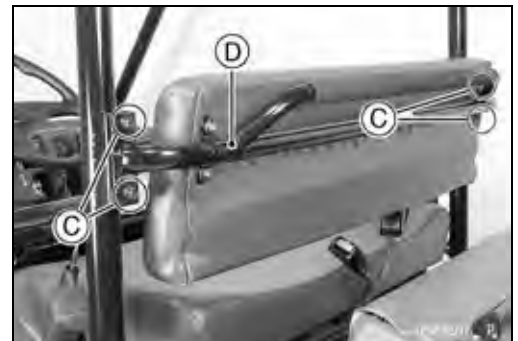
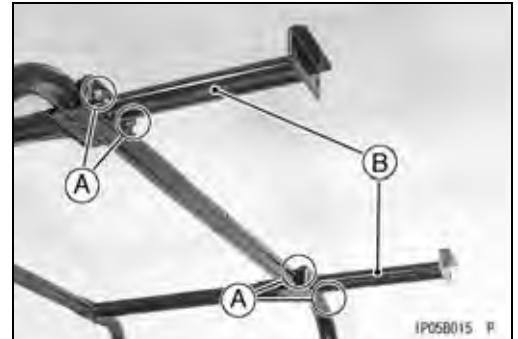

- Remove:
  - Front Bar Mounting Bolts (Upper Side only)
  - Center Bar Mounting Bolts [A]
  - Center Bar [B]

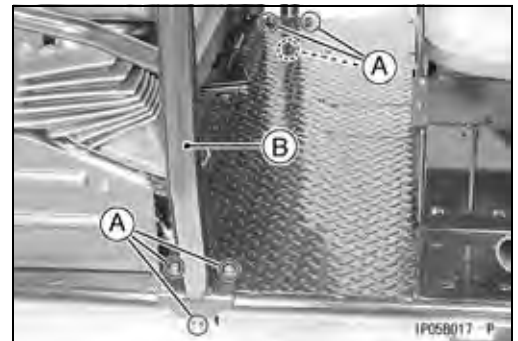

*Center Bar Installation*

- Tighten:
  - Torque - Center Bar Mounting Bolts: 44 N·m (4.5 kgf·m, 33 ft·lb)**
  - Top Bar Mounting Bolts: 44 N·m (4.5 kgf·m, 33 ft·lb)**

## 16-18 FRAME

### Front, Center and Rear Bars

#### *Cargo Bed Latch Position Inspection*

- Cargo bed must be latched securely on the cargo bed or the rear seat hooks [B] without rattling.

[A] Latch

- ★ If there is rattling or not snug enough, adjust the latch positions.

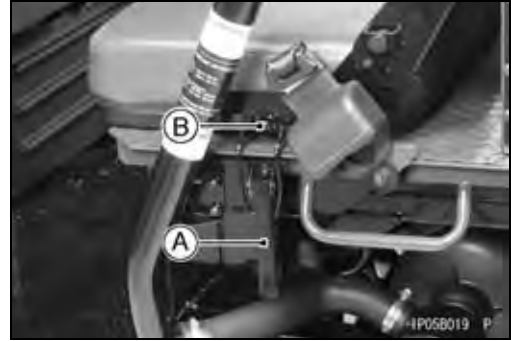

#### *Cargo Bed Latch Position Adjustment*

- Release the mounting bolts [A].
- Reposition the latch to the suitable place by sliding within the ellipse bolt holes.
- Retighten the mounting bolts.

#### **NOTE**

○ Adjustment must be made on both sides.

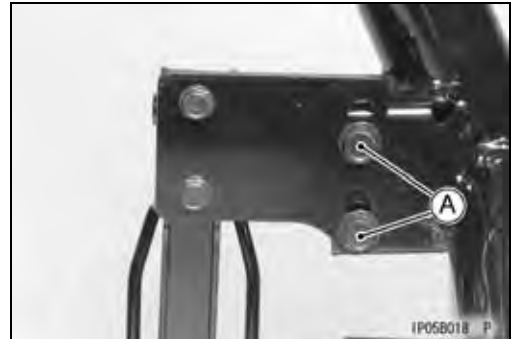

## Front Fender Assembly

### Front Cover Removal

- Remove:
  - Front Cargo Hood (see Front Cargo Hood Removal)
  - Guard Bolts [A]
  - Collars [B]
  - Guard [C]

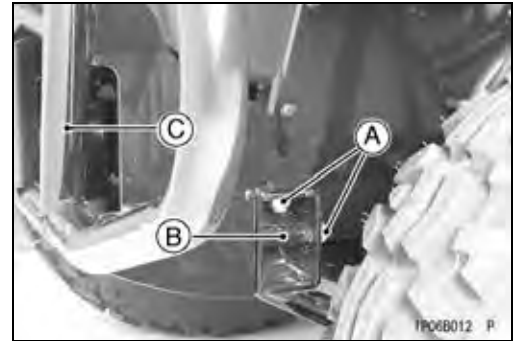

- Remove:
  - Screws [A]
  - Guard [B]

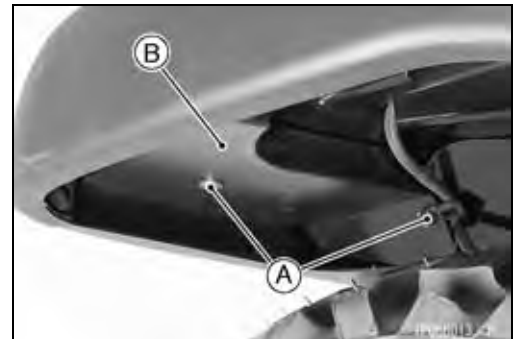

- Remove:
  - Screws [A]



- Remove:
  - Rivets [A]

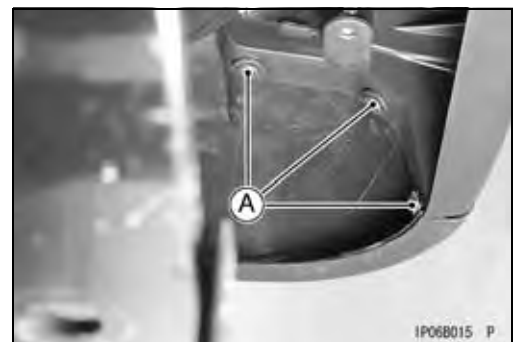

- Remove:
  - Rivets [A]
  - Screws [B]
  - Front Cover [C]

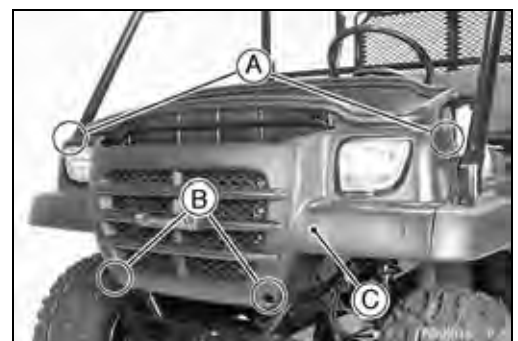

## 16-20 FRAME

### Front Fender Assembly

#### *Front Fender Removal*

- Remove:

- Screws [A]
- Guard [B]

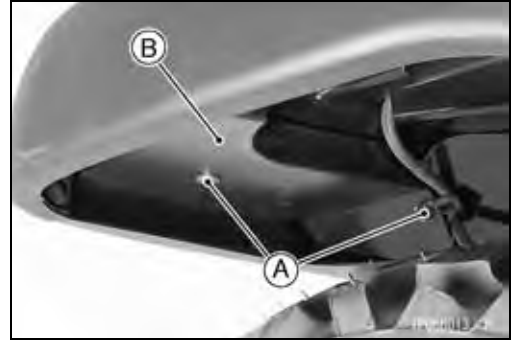

- Remove:

- Coolant Reserve Tank from Frame
- Rivets [A]

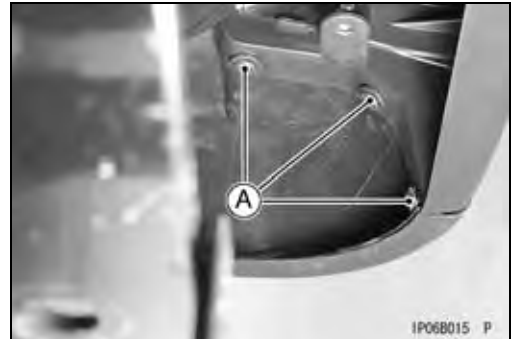

- Remove:

- Screws [A]
- Plugs [B] and Screws
- Screws [C] and Nuts
- Front Fender [D]

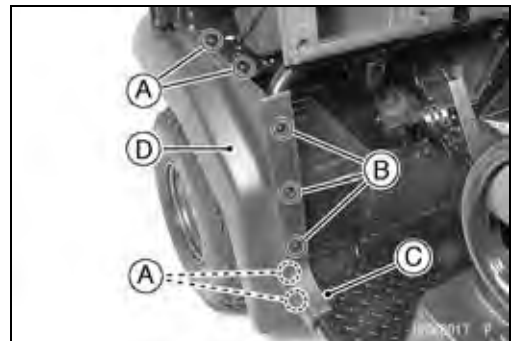

#### *Radiator Side Cover Removal*

- Remove:

- Screws [A]
- Guard [B]

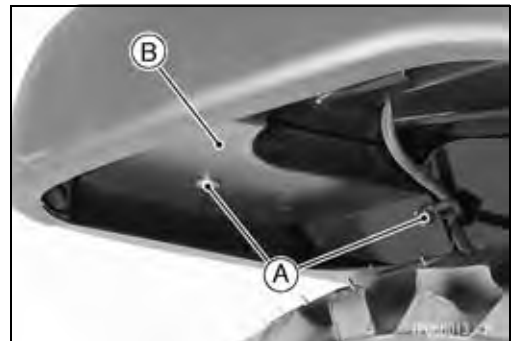

- Remove:

- Screws [A]
- Radiator Side Covers [B]

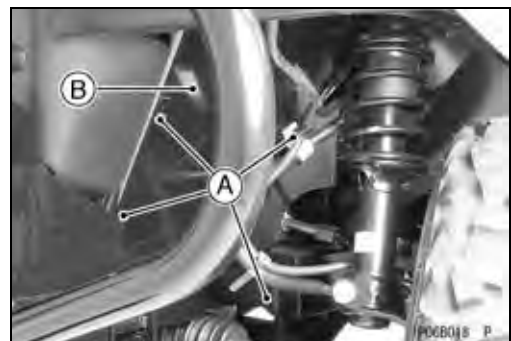

## Front Fender Assembly

### Radiator Side Cover Installation

- Apply adhesive agent:  
Radiator Side Cover Trims [A]

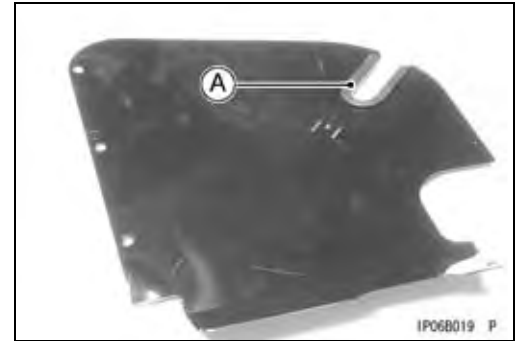

### Radiator Side Cover Flap Removal

- Remove:  
Radiator Side Cover (see Radiator Side Cover Removal)  
Screw [A], Nut and Washer  
Radiator Side Cover Flap [B]



### Floor Center Panel Removal

- Remove:  
Screws [A]  
Mounting Rivets [B]  
Front Seat Lower Cover (Front Side) [C]

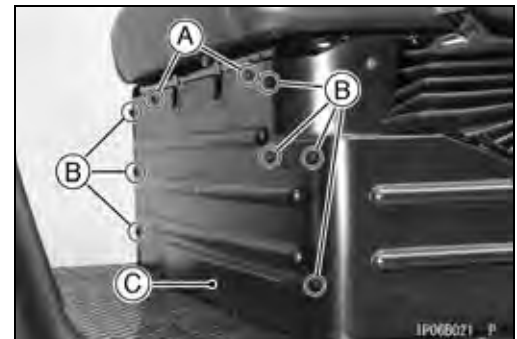

- Remove:  
Screws [A]  
Floor Center Panel (Front Side) [B]

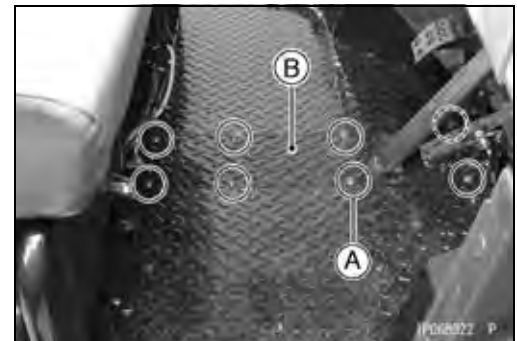

- Remove the fuel tank (see Fuel System chapter).
- Remove:  
Screws [A]  
Rear Seat Lower Cover [B]

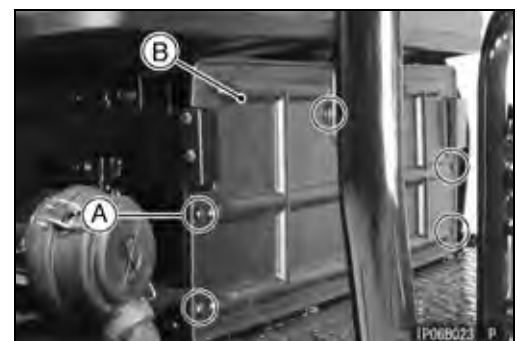

## 16-22 FRAME

### Front Fender Assembly

---

- Remove:
  - Screws [A]
  - Floor Center Panel (Rear Side) [B]

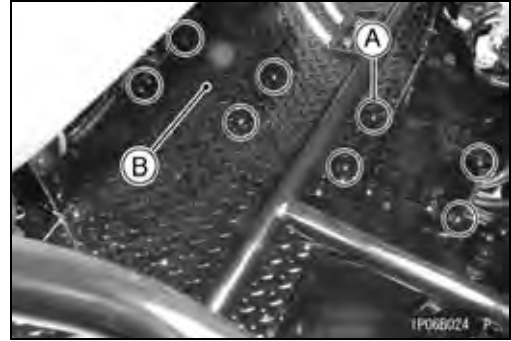



---

## Rear End Sub-frame

---

### *Rear End Sub-frame Removal*

- Remove:
  - Engine (see Engine Removal/Installation chapter)
  - Transmission Case (see Transmission chapter)
  - Rear End Sub-frame Mounting Bolts [A] and Nuts
  - Rear End Sub-frame [B]

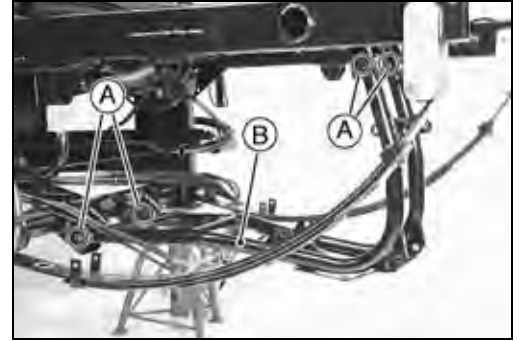

### *Rear End Sub-frame Installation*

- Tighten:
  - Torque - Rear End Sub-frame Mounting Nuts: 44 N·m (4.5 kgf·m, 33 ft·lb)



# Electrical System

## Table of Contents

Exploded View.....	17-2	Starter Motor Removal.....	17-31
Specifications .....	17-6	Starter Motor Installation.....	17-31
Special Tools .....	17-7	Starter Motor Disassembly.....	17-31
Parts Location.....	17-8	Starter Motor Assembly .....	17-33
Precautions.....	17-11	Carbon Brush Inspection .....	17-34
Battery .....	17-13	Yoke Inspection.....	17-34
Battery Removal .....	17-13	Brush Plate Inspection .....	17-34
Battery Installation .....	17-13	Commutator Cleaning/Inspection.	17-34
Battery Activation.....	17-14	Armature Inspection.....	17-35
Precautions.....	17-16	Pinion Gear Inspection.....	17-35
Interchange.....	17-16	Starter Switch Inspection .....	17-35
Charging Condition Inspection....	17-17	Starter Circuit Relay Inspection ...	17-36
Refreshing Charge .....	17-17	Fuel Pump and Relay .....	17-38
Charging System.....	17-19	Fuel Pump Operational	
Alternator Rotor and Stator		Inspection.....	17-38
Removal.....	17-19	Fuel Pump Relay Internal	
Alternator Rotor and Stator		Resistance .....	17-38
Installation.....	17-20	Radiator Fan .....	17-40
Charging System Operational		Radiator Fan Circuit Inspection ...	17-40
Inspection.....	17-21	Radiator Fan Motor Inspection....	17-40
Stator Coil Resistance .....	17-22	Lighting System.....	17-41
Regulator/Rectifier Inspection.....	17-22	Headlight Beam Adjustment .....	17-41
Ignition System.....	17-25	Headlight Bulb Replacement .....	17-41
Spark Plug Removal/Installation..	17-25	Tail/Brake Light Replacement .....	17-42
Spark Plug Gap Inspection .....	17-25	Switches .....	17-44
Spark Plug Cleaning/Inspection...	17-25	Brake Light Switch Adjustment ....	17-44
Ignition Coil Removal.....	17-25	Switch Inspection .....	17-44
Ignition Coil Installation.....	17-26	Radiator Fan Switch Inspection ...	17-44
Ignition Coil Inspection.....	17-26	Coolant Temperature Warning	
Ignition Coil Primary Peak Voltage		Light Switch Inspection .....	17-45
Inspection.....	17-26	Fuses.....	17-46
Pickup Coil Removal.....	17-27	Fuse Removal.....	17-46
Pickup Coil Inspection.....	17-27	Fuse Installation.....	17-46
Pickup Coil Peak Voltage		Fuse Inspection.....	17-46
Inspection.....	17-28	Electrical Wiring.....	17-47
Ignition System Inspection.....	17-29	Wiring Inspection .....	17-47
Electric Starter System .....	17-31	Wiring Diagram.....	17-48

# 17-2 ELECTRICAL SYSTEM

## Exploded View

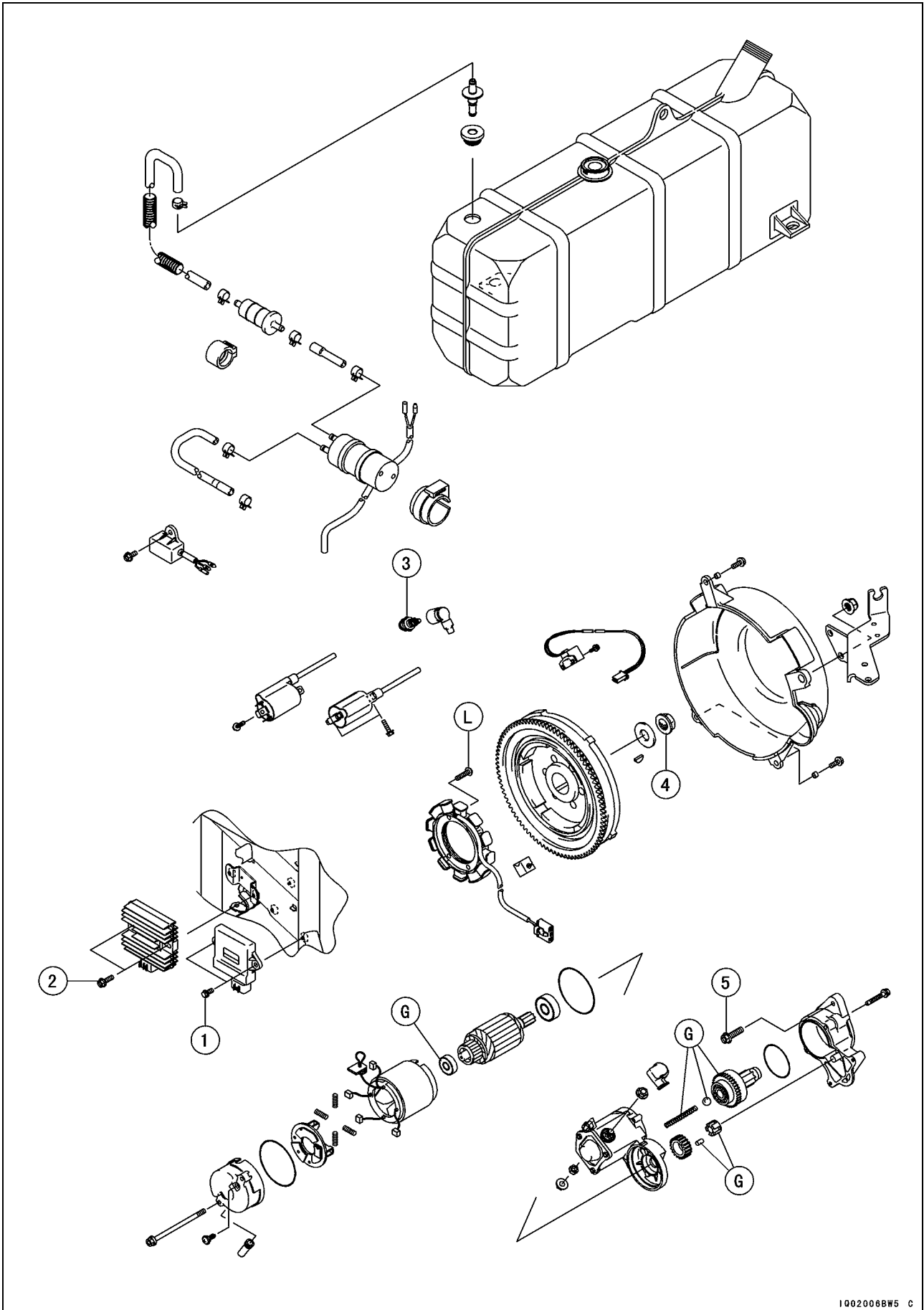

**Exploded View**

No.	Fastener	Torque			Remarks
		N-m	kgf-m	ft-lb	
1	Igniter Mounting Bolts	8.8	0.90	78 in-lb	
2	Regulator/Rectifier Mounting Bolts	8.8	0.90	78 in-lb	
3	Spark Plugs	17	1.7	12	
4	Alternator Rotor Nut	120	12	87	
5	Starter Motor Mounting Bolts	22	2.2	16	

L: Apply a non-permanent locking agent.

G: Apply grease.

# 17-4 ELECTRICAL SYSTEM

## Exploded View

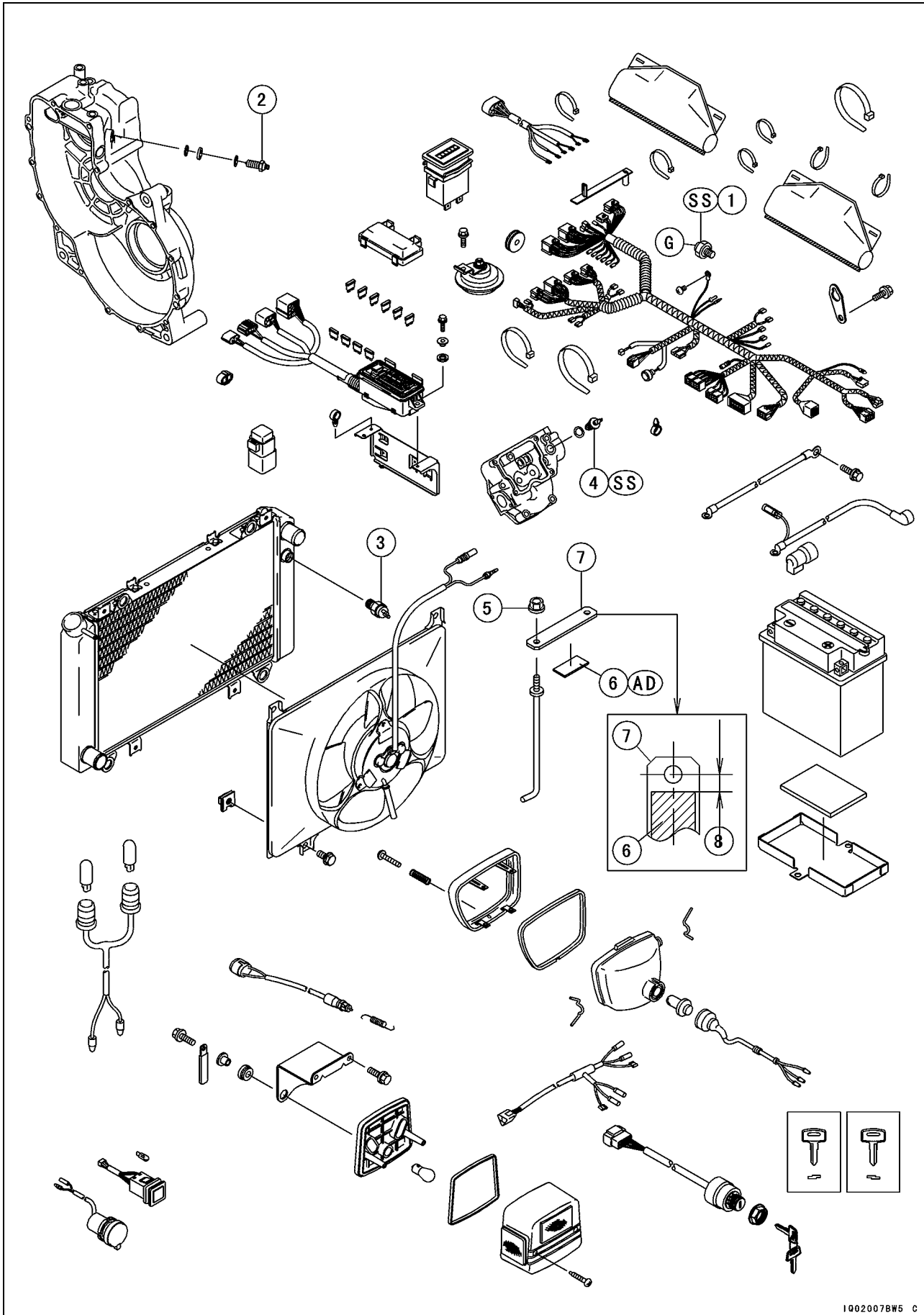

1002007BW5 C

**Exploded View**

No.	Fastener	Torque			Remarks
		N·m	kgf·m	ft·lb	
1	Oil Pressure Switch	9.8	1.0	87 in·lb	SS
2	Neutral Switch	15	1.5	11	
3	Radiator Fan Switch	25	2.5	18	
4	Coolant Temperature Warning Light Switch	23	2.3	17	SS
5	Battery Holder Nuts	17	1.7	12	

6. Battery Holder

7. Damper

8. 10 ~ 15 mm (0.39 ~ 0.59 in.)

G: Apply grease to the wire terminal.

SS: Apply silicone sealant.

## 17-6 ELECTRICAL SYSTEM

### Specifications

Item	Standard	Service Limit
<b>Battery</b>		
Type	Sealed battery	---
Capacity	12 V 18 Ah	---
Voltage	12.8 V or more	---
<b>Charging System</b>		
Type	Three-phase AC	---
Regulator/rectifier output voltage	Battery voltage ~ 15 V	---
Stator coil resistance	0.2 ~ 0.4 $\Omega$	---
<b>Ignition System</b>		
Spark plug gap	0.7 ~ 0.8 mm (0.028 ~ 0.031 in.)	---
Ignition coil winding resistance:		
Primary winding	1.87 ~ 2.53 $\Omega$	---
Secondary winding	10.4 ~ 15.6 k $\Omega$	---
Ignition coil primary peak voltage	264 V or more	---
Pickup coil resistance	88 ~ 132 $\Omega$	---
Pickup coil peak voltage	4.5 V or more	---
<b>Electric Starter System</b>		
Starter motor:		
Carbon brush length	15.5 mm (0.61 in.)	8.5 mm (0.33 in.)
Commutator diameter	30 mm (1.18 in.)	29 mm (1.14 in.)
<b>Fuel Pump and Relay</b>		
Fuel pump relay internal resistance	in the text	---
<b>Switches</b>		
Brake light switch timing	ON after 10 mm (0.4 in.) of pedal travel	---
Radiator fan switch resistance:		
Rising temperature	From OFF to ON at 86 ~ 90°C (187 ~ 194°F)	---
Falling temperature	From ON to OFF at 81 ~ 85°C (178 ~ 185°F) ON: Less than 0.5 $\Omega$ OFF: More than 1 M $\Omega$	---
Coolant temperature warning light switch resistance:		
Rising temperature	From OFF to ON at 108 ~ 114°C (226 ~ 237°F)	---
Falling temperature	From ON to OFF within 7°C (45°F) of "ON" temperature ON: Less than 0.5 $\Omega$ OFF: More than 1 M $\Omega$	---



**Special Tools**

**Crankcase Splitting Tool Assembly:  
57001-1098**

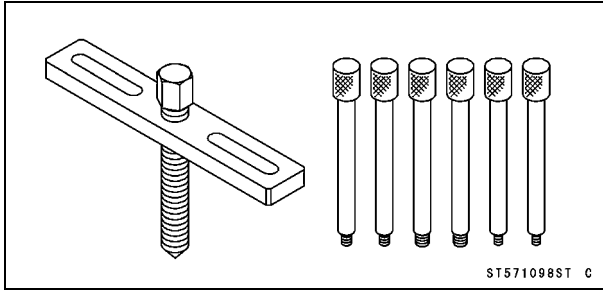

**Peak Voltage Adapter:  
57001-1415**

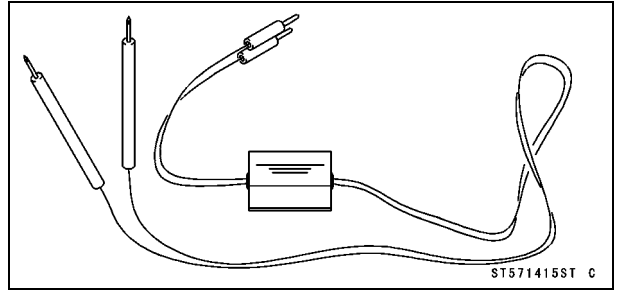

**Hand Tester:  
57001-1394**

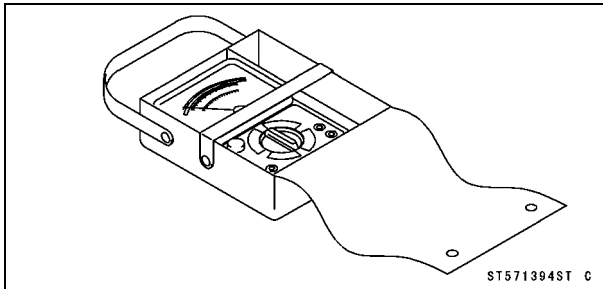

**Needle Adapter Set:  
57001-1457**

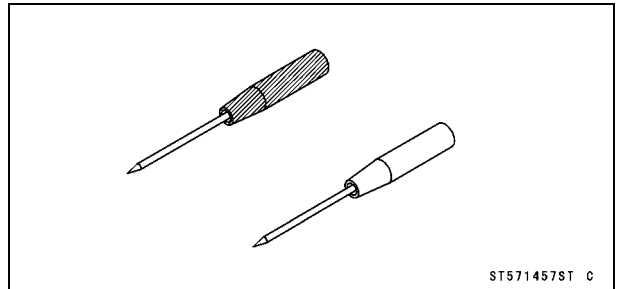

## 17-8 ELECTRICAL SYSTEM

### Parts Location

Horn [A]  
Radiator Fan Switch [B]  
Radiator Fan [C]

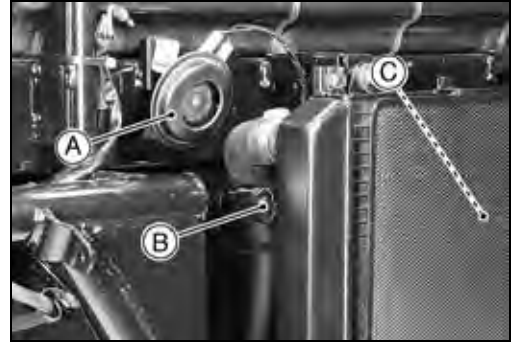

Brake Light Switch [A]

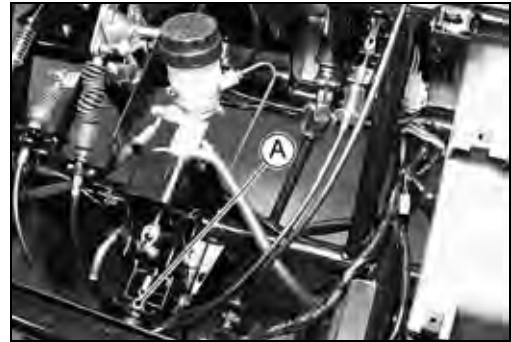

Horn Button [A]  
Light Switch [B]  
Hour Meter [C]  
Ignition Switch [D]  
Coolant Temperature Warning Indicator Light [E]  
Parking Brake Indicator Light [F]

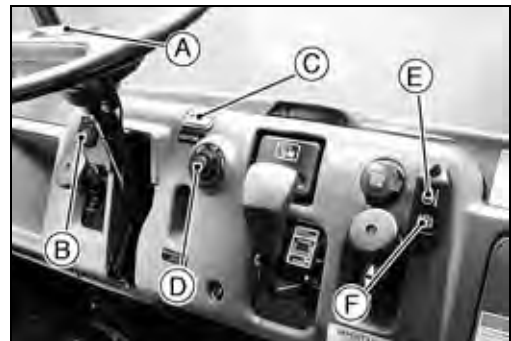

Battery [A]



Starter Circuit Relay [A]  
Regulator/Rectifier [B]  
Fuel Pump Relay [C]  
Parking Brake Light Switch [D]  
Igniter [E]

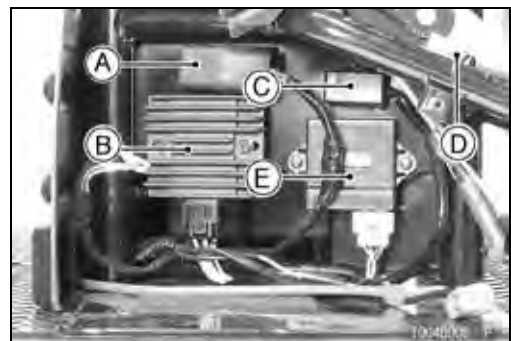

Parts Location

Fuse Box [A]  
Ground Wire (Frame) [B]

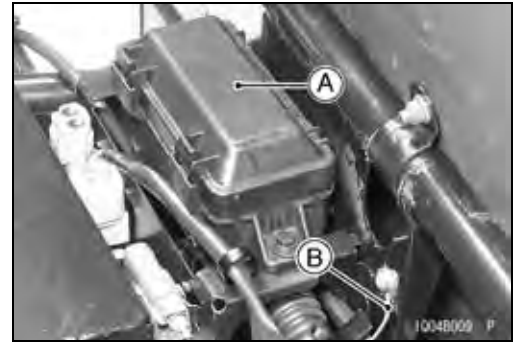

Coolant Temperature Warning Indicator Light Switch [A]



Spark Plugs [A]  
Ignition Coils [B]

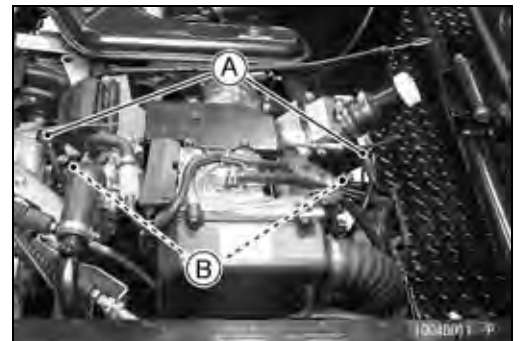

Ground Wire (Engine) [A]  
Starter Motor [B]

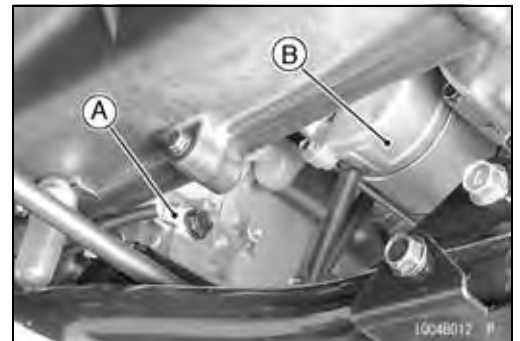

Neutral Switch [A]



## 17-10 ELECTRICAL SYSTEM

### Parts Location

---

Oil Pressure Switch [A]



Alternator [A]  
Pickup Coil [B]  
Fuel Pump [C]

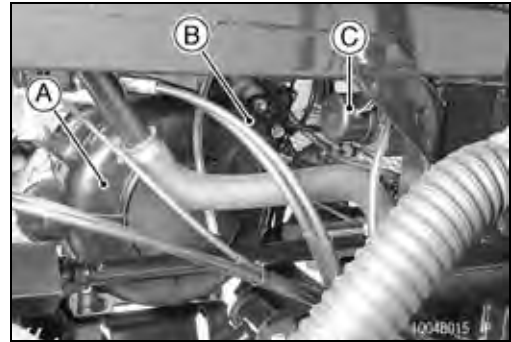

## Precautions

There are a number of important precautions that are musts when servicing electrical systems. Learn and observe all the rules below.

- Do not reverse the battery lead connections. This will burn out the diodes in the electrical parts.
- Always check battery condition before condemning other parts of an electrical system. A fully charged battery is a must for conducting accurate electrical system tests.
- The electrical parts should never be struck sharply, as with a hammer, or allowed to fall on a hard surface. Such a shock to the parts can damage them.
- To prevent damage to electrical parts, do not disconnect the battery wires or any other electrical connections when the main switch is on, or while the engine is running.
- Because of the large amount of current, never keep the main switch turned to the start position when the starter motor will not turn over, or the current may burn out the starter motor windings.
- Take care not to short the wires that are directly connected to the battery positive (+) terminal to the chassis ground.
- Troubles may involve one or in some cases all items. Never replace a defective part without determining what CAUSED the failure. If the failure was brought on by some other item or items, they too must be repaired or replaced, or the replacement part will soon fail again.
- Make sure all connectors in the circuit are clean and tight, and examine wires for signs of burning, fraying, etc. Poor wires and bad connections will affect electrical system operation.
- Measure coil and winding resistance when the part is cold (at room temperature).
- Color Codes:

BK: Black	G: Green	P: Pink
BL: Blue	GY: Gray	PU: Purple
BR: Brown	LB: Light Blue	R: Red
CH: Chocolate	LG: Light Green	W: White
DG: Dark Green	O: Orange	Y: Yellow

- Electrical Connectors:  
Female Connectors [A]

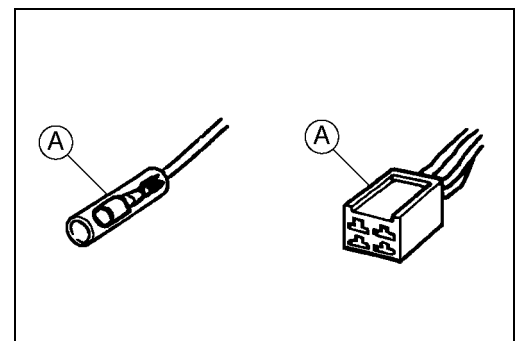

# 17-12 ELECTRICAL SYSTEM

## Precautions

Male Connectors [B]

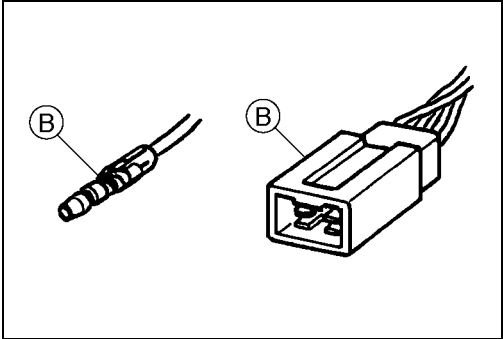

## Battery

### Battery Removal

- Remove:
  - Mounting Rivets [A]
  - Screws [B]
  - Battery Cover [C]

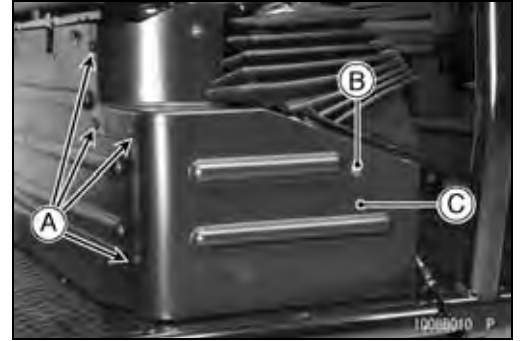

- Remove:
  - Left Side Cover (see Frame chapter)
  - Battery Holder Nuts [A]
  - Battery Holder [B]

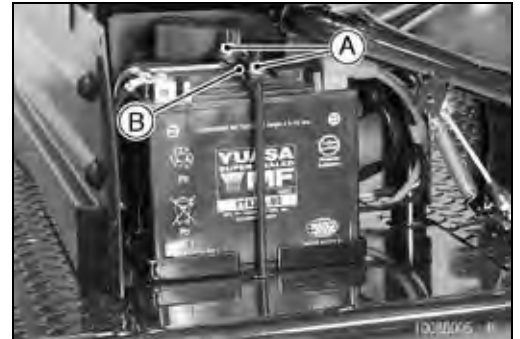

- Disconnect the negative terminal wire [A] first, and then positive terminal wire [B].

<b>CAUTION</b>
<b>Be sure to disconnect the negative terminal wire first.</b>

- Remove:
  - Battery [C]



### Battery Installation

- Check that the rubber dampers [A] on the battery holder [B] and floorboard [C] are properly in place.

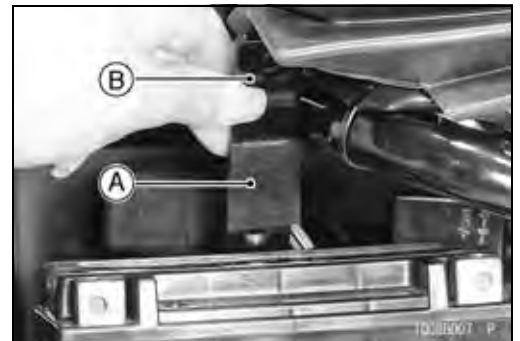

## 17-14 ELECTRICAL SYSTEM

### Battery

- Put the battery in place on the rubber damper.
- Connect the three positive wires [A] first, and then connect the negative wire [B].
- Put a light coat of grease on the terminals to prevent corrosion.
- Install the battery holder.
- Tighten:
  - Torque - Battery Holder Nuts: 17 N·m (1.7 kgf·m, 12 ft·lb)
- Install the battery cover.



#### Battery Activation

##### Electrolyte Filling

- Make sure that the model name [A] of the electrolyte container matches the model name [B] of the battery. These names must be the same.

Battery Model Name for KAF620-J1/K1: YTX20L-BS

#### CAUTION

Be sure to use the electrolyte container with the same model name as the battery since the electrolyte volume and specific gravity vary with the battery type. This is to prevent overfilling of the electrolyte, shorting the battery life, and deterioration of the battery performance.

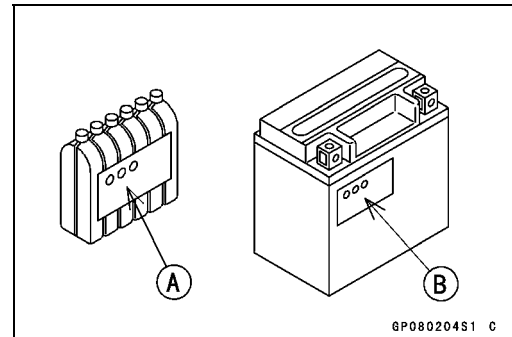

#### CAUTION

Do not remove the aluminum sealing sheet [A] from the filler ports [B] until just prior to use. Be sure to use the dedicated electrolyte container for correct electrolyte volume.

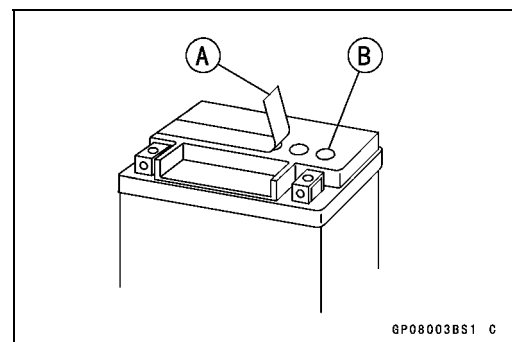

- Place the battery on a level surface.
- Check to see that the sealing sheet has no peeling, tears, or holes in it.
- Remove the sealing sheet.

#### NOTE

○ The battery is vacuum sealed. If the sealing sheet has leaked air into the battery, it may require a longer initial charge.

- Remove the electrolyte container from the vinyl bag.
- Detach the strip of caps [A] from the container and set aside, these will be used later to seal the battery.

#### NOTE

○ Do not pierce or otherwise open the sealed cells [B] of the electrolyte container. Do not attempt to separate individual cells.

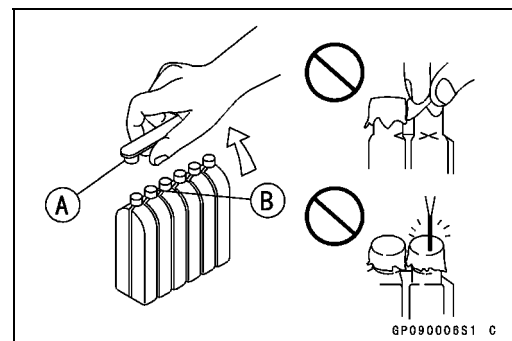



## Battery

- Place the electrolyte container upside down with the six sealed cells into the filler ports of the battery. Hold the container level, push down to break the seals of all six cells. You will see air bubbles rising into each cell as the ports fill.

### NOTE

- Do not tilt the electrolyte container

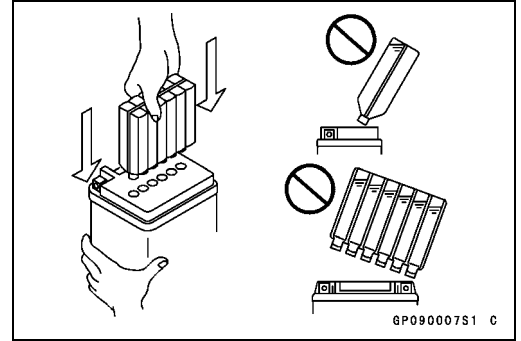

- Check the electrolyte flow.
- ★ If no air bubbles [A] are coming up from the filler ports, or if the container cells have not emptied completely, tap the container [B] a few times.
- Keep the container in place for **20** minutes or more. Don't remove the container from the battery until it's empty, the battery requires all the electrolyte from the container for proper operation.

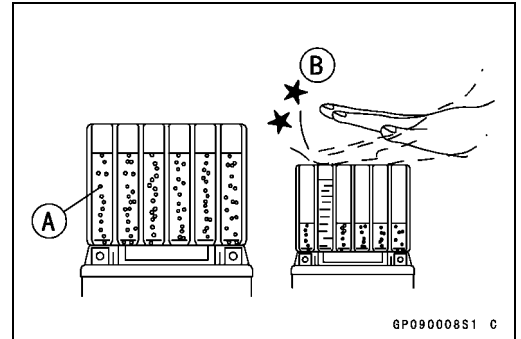

### CAUTION

**Removal of the container before it is completely empty can shorten the service life of the battery. Do not remove the electrolyte container until it is completely empty and 20 minutes have elapsed.**

- Gently remove the container from the battery.
- Let the battery sit for **60** minutes prior to charging to allow the electrolyte to permeate into the plates for optimum performance.

### NOTE

- Charging the battery immediately after filling can shorten service life. Let the battery sit for at least **60** minutes after filling.

### Initial Charge

- Place the strip [A] of caps loosely over the filler ports.
- Newly activated sealed batteries require an initial charge.

**Standard Charge 1.8 A x 5 ~ 10 hours**

- ★ If using a recommended battery charger, follow the charger's instructions for newly activated sealed battery.

#### Kawasaki-recommended chargers

**Optimate III**

**Yuasa 1.5 Amp Automatic Charger**

**Battery Mate 150-9**

- ★ If the above chargers are not available, use equivalent one.

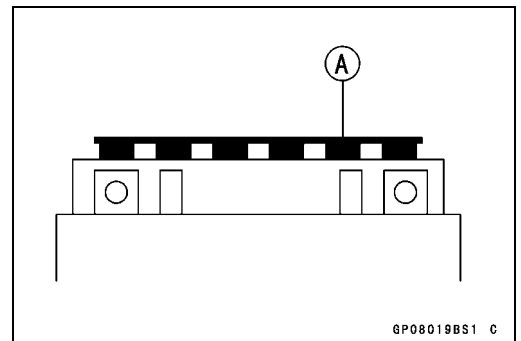

### NOTE

- Charging rates will vary depending on how long the battery has been stored, temperature, and the type of charger used. Let battery sit 30 minutes after initial charge, then check voltage using a voltmeter. If it is not at least 12.8 volts, repeat charging cycle.

## 17-16 ELECTRICAL SYSTEM

### Battery

- After charging is completed, press down firmly with both hands to seat the strip of caps [A] into the battery (don't pound or hammer). When properly installed, the strip of the caps will be level with the top of the battery.

#### CAUTION

Once the strip of the caps [A] is installed onto the battery, never remove the caps, nor add water or electrolyte to the battery.

#### NOTE

- To ensure maximum battery life and customer satisfaction, it is recommended the battery be load tested at three times its amp-hour rating for 15 seconds. Re-check voltage and if less than 12.8 volts repeat the charging cycle and load test. If still below 12.8 volts the battery is defective.

#### Precautions

- 1) No need of topping-up

No topping-up is necessary in this battery until it ends its life under normal use. Forcibly prying off the sealing plug to add water is very dangerous. Never do that.

- 2) Refreshing charge

If an engine will not start, a horn sounds weak, or lamps are dim, it indicates the battery has been discharged. Give refresh charge for 5 to 10 hours with charge current shown in the specification (see Refreshing Charge).

When a fast charge is inevitably required, do it following precisely the maximum charge current and time conditions indicated on the battery.

#### CAUTION

**This battery is designed to sustain no unusual deterioration if refresh-charged according to the method specified above. However, the battery's performance may be reduced noticeably if charged under conditions other than given above.**

**Never remove the seal caps during refresh charge.**

**If by chance an excessive amount of gas is generated due to overcharging, the safety valve operates to keep the battery safe.**

- 3) When you do not use the vehicle for months

Give a refresh charge before you store the vehicle and store it with the negative lead removed. Give a refresh charge once a month during storage.

- 4) Battery life

If the battery will not start the engine even after several refresh charges, the battery has exceeded its useful life. Replace it. (Provided, however, the vehicle's starting system has no problem.)

#### ⚠ WARNING

**Keep the battery away from sparks and open flames during charging, since the battery gives off an explosive gas mixture of hydrogen and oxygen. When using a battery charger, connect the battery to the charger before turning on the charger. This procedure prevents sparks at the battery terminals which could ignite any battery gases.**

**No fire should be drawn near the battery, or no terminals should have the tightening loosened.**

**The electrolyte contains sulfuric acid. Be careful not to have it touch your skin or eyes. If touched, wash it off with liberal amount of water. Get medical attention if severe.**

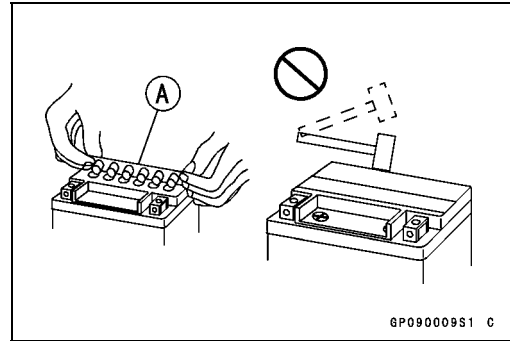

GP090009S1 C

#### Interchange

A sealed battery can fully display its performance only when combined with a proper vehicle electrical system. Therefore, replace a sealed battery only on a vehicle which was originally equipped with

**Battery**

a sealed battery.

Be careful, if a sealed battery is installed on a vehicle which had an ordinary battery as original equipment, the sealed battery's life will be shortened.

*Charging Condition Inspection*

Battery charging condition can be checked by measuring battery terminal voltage.

- Remove the battery (see Battery Removal).

**CAUTION**

**Be sure to disconnect the negative (-) lead first.**

- Measure the battery terminal voltage.

**NOTE**

○ Measure with a digital voltmeter [A] which can be read to one decimal place voltage.

- ★ If the reading is below the specified, refreshing charge is required.

**Battery Terminal Voltage**

Standard: 12.8 V or more

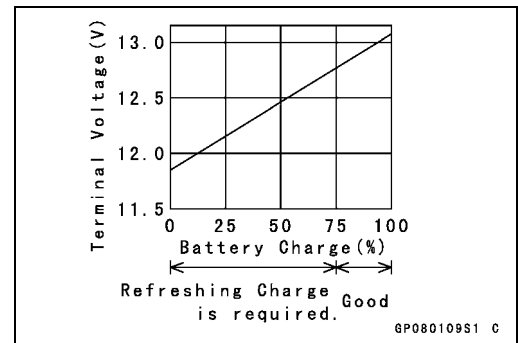
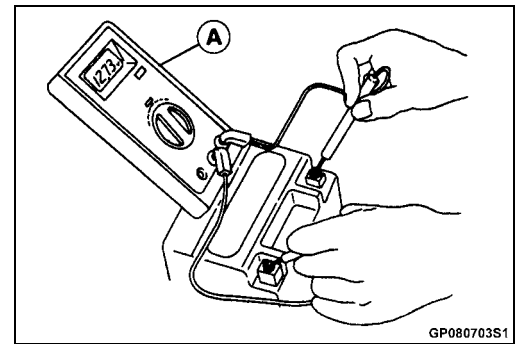

*Refreshing Charge*

- Remove the battery [A] (see Battery Removal).
- Refresh-charge by following method according to the battery terminal voltage.

**⚠ WARNING**

**This battery is sealed type. Never remove seal sheet [B] even at charging. Never add water. Charge with current and time as stated below.**

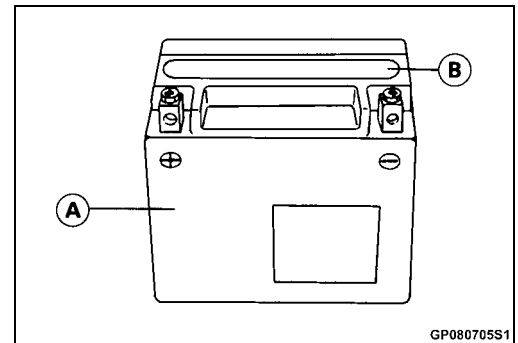

Terminal Voltage: 11.5 ~ less than 12.5 V

Standard Charge

1.8 A x 5 ~ 10 h (see following chart)

Quick Charge

9.0 A x 1.0 h

**CAUTION**

**If possible, do not quick charge. If the quick charge is done due to unavoidable circumstances, do the standard charge later on.**

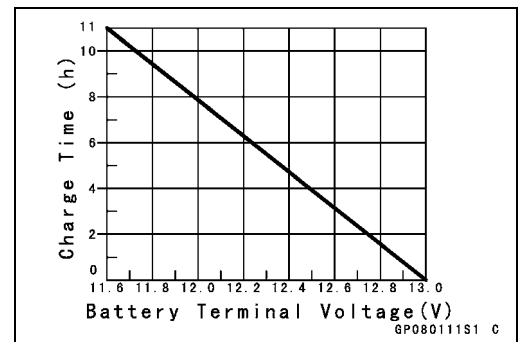

Terminal Voltage: less than 11.5 V

Charging Method: 1.8 A x 20 h

# 17-18 ELECTRICAL SYSTEM

## Battery

### NOTE

○ Increase the charging voltage to a maximum voltage of 25 V if the battery will not accept current initially. Charge for no more than 5 minutes at the increased voltage then check if the battery is drawing current. If the battery will accept current [D], decrease the voltage and charge by the standard charging method described on the battery case. If the battery will not accept current after 5 minutes, replace the battery.

Battery [A]

Battery Charger [B]

Standard Value [C]

- Determine battery condition after refreshing charge.
- Determine the condition of the battery 30 minutes after completion of the charge by measuring the terminal voltage according to the table below.

Criteria	Judgement
12.8 V or higher	Good
12.0 ~ 12.5 V or lower	Charge insufficient → Recharge
12.0 V or lower	Unserviceable → Replace

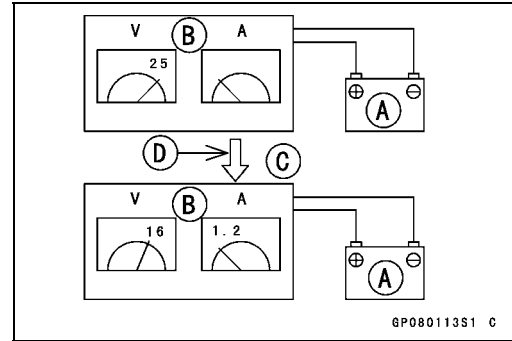

## Charging System

### Alternator Rotor and Stator Removal

- Remove, if the engine is mounted on the frame:
  - Cargo Bed
  - Propeller Shafts
- Remove:
  - Alternator Cover Bolts [A]
  - Alternator Cover [B]
- Remove:
  - Pickup Coil (see Pickup Coil Removal)
  - Alternator Rotor Nut [A]
- Hold the alternator rotor [B] with a suitable holder [C].

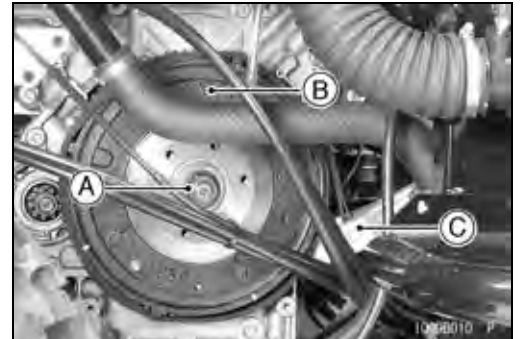

- Using a puller (special tool) and suitable collars [A], remove the alternator rotor [B] as shown.

**Special Tool - Crankcase Splitting Tool Assembly [C]:  
57001-1098**

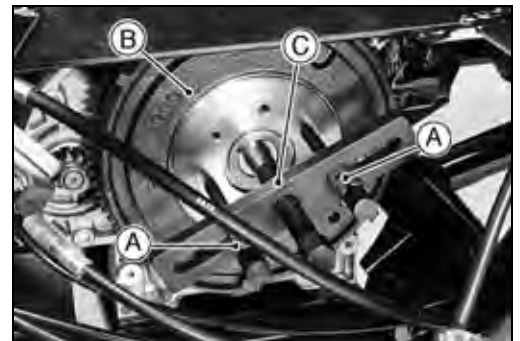

### NOTE

- If a puller is not available, screw the alternator rotor nut flush with the shaft end to prevent damaged shaft end threads and tap sharply and squarely on the nut to break the rotor loose.

### CAUTION

**Do not attempt to strike the alternator rotor itself. Striking the rotor can cause the magnets to lose their magnetism.**

## 17-20 ELECTRICAL SYSTEM

### Charging System

- Disconnect the alternator wire connector [A].

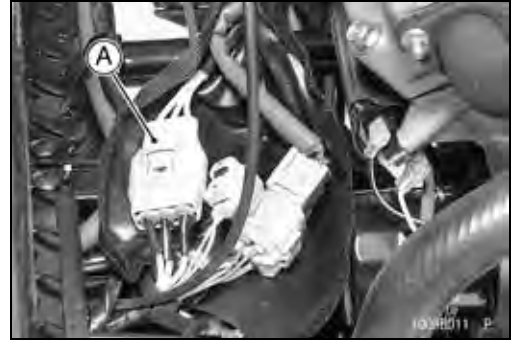

- Remove:
  - Alternator Stator Mounting Screws [A]
  - Alternator Stator [B]



#### *Alternator Rotor and Stator Installation*

- Apply non-permanent locking agent:
  - Alternator Stator Mounting Screws
- Clean [A] the inside of the alternator rotor [B] and end of the crankshaft [C] or the taper will not fit snugly.
- Fit the rotor onto the crankshaft so that the key [D] fits in the groove in the hub of the rotor.
- Install:
  - Washer [E]
- Tighten:
  - Torque - Alternator Rotor Nut [F]: 120 N-m (12 kgf-m, 87 ft-lb)

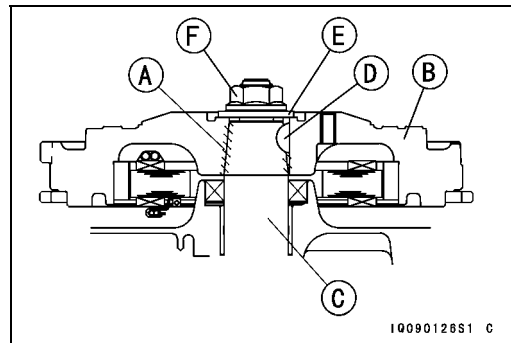

## Charging System

- Install:
  - Pickup Coil (see Pickup Coil Installation)
- Route the electrical wires as shown.
  - Alternator Wire [A]
  - Pickup Coil Wires [B]
  - Bands [C]

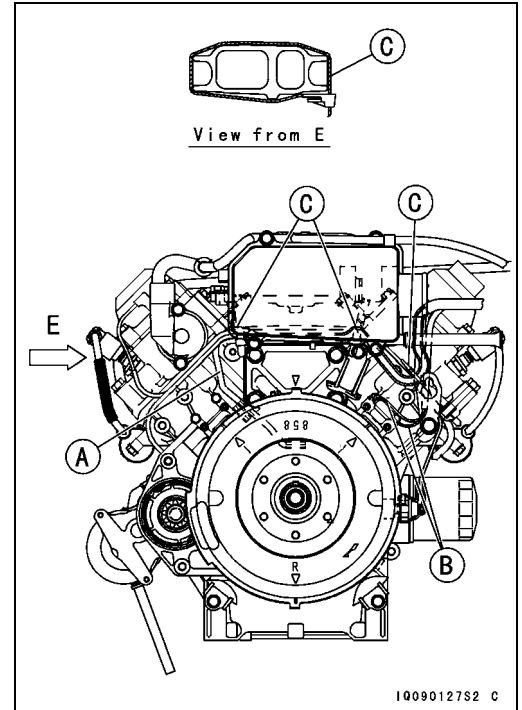

### Charging System Operational Inspection

- Check battery condition.

#### NOTE

- Always check battery condition before condemning other parts of the charging system. The battery must be fully charged in order to conduct accurate charging system tests.
- Warm up the engine to bring the components up to their normal operating temperatures.
- Measure regulator/rectifier output voltage at various engine speeds with the headlights turned on and then turned off.
- Connect a voltmeter across the battery terminals.
- The readings should show nearly battery voltage when the engine speed is low, and as the engine speed rises, the readings should also rise. But they must stay within the specified range.
- ★ If the output voltage is much higher than the specification, the regulator/rectifier is defective, or the regulator/rectifier wires are loose or open.
- ★ If the output voltage does not rise as the engine speed increase then the regulator/rectifier is defective or the alternator output is insufficient for the loads.

#### Regulator/Rectifier Output Voltage

Standard: Battery Voltage ~ 15 V



# 17-22 ELECTRICAL SYSTEM

## Charging System

### Stator Coil Resistance

- Disconnect the alternator wire connector.
- Measure the stator coil resistance.
- Connect an ohmmeter between the alternator wires.

#### Stator Coil Resistance

Standard: 0.2 ~ 0.4 Ω

- ★ If the meter does not read as specified, replace the alternator stator.
- ★ If the coil has normal resistance, but the voltage inspect showed the alternator to be defective; then the rotor magnets have probably weakened, and the rotor must be replaced.

### Regulator/Rectifier Inspection

- Remove the regulator/rectifier [A].

#### Rectifier Circuit Test

- Check the resistance in both directions between the terminals following the table.

Tester Connection	W-BK1, W-BK2, W-BK3
	BK/Y-BK1, BK/Y-BK2, BK/Y-BK3

- ★ The resistance should be low in one direction and more than ten times as much in the other direction. If any two terminals are low or high in both directions, the rectifier is defective and must be replaced.

#### NOTE

- The actual meter reading varies with the meter used and the individual rectifier, but, generally speaking the lower reading should be from zero to the first 1/2 of the scale.

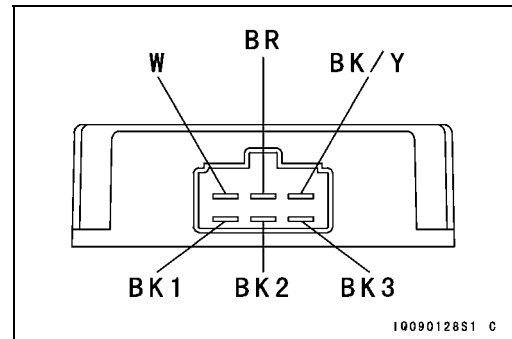
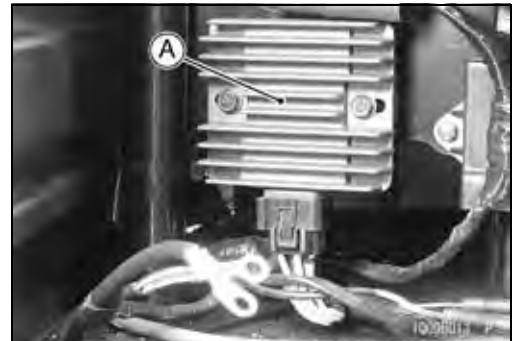

### Regulator Circuit Test

- Prepare testing tools:

- Test Light Bulb rated 12 V and 3 ~ 6 W (with socket and wires)
- Batteries Three 12 V batteries
- Test Wires Four auxiliary wires

#### CAUTION

The test light limits the current flow through the regulator/rectifier. Do not use an ammeter or multimeter in its place.



## Charging System

### Regulator Circuit Test-1st Step:

- Connect the test light and the 12 V battery to the regulator/rectifier as shown.
- Check BK1, BK2, and BK3 terminals respectively.

#### CAUTION

**The test light limits the current flow through the regulator/rectifier. Do not use an ammeter or multimeter in its place.**

- ★ If the test light turns on, the regulator/rectifier is defective. Replace it.
- ★ If the test light does not turn on, continue the test.

### Regulator Circuit Test-2nd Step:

- Connect the test light and the 12 V battery in the manner as specified in the "Regulator Circuit Test-1st Step."
- Apply 12 V to BR terminal.
- Check BK1, BK2, and BK3 terminals respectively.
- ★ If the test light turns on, the regulator/rectifier is defective. Replace it.
- ★ If the test light does not turn on, continue the test.

### Regulator Circuit Test-3rd Step:

- Connect the test light and the 12 V battery in the same manner as specified in the "Regulator Circuit Test-1st Step."
- Momentarily apply 24 V to BR terminal by adding a 12V battery.
- Check BK1, BK2, and BK3 terminals respectively.

#### CAUTION

**Do not apply more than 24 V to the regulator/rectifier and do not leave the 24 V applied for more than a few seconds, or the unit will be damaged.**

- ★ If the test light did not light when the 24 V was applied momentarily to the BR terminal, the regulator/rectifier is defective. Replace it.
- ★ If the regulator/rectifier passes all of the tests described, it may still be defective. If the charging system still does not work properly after checking all of the components and the battery, test the regulator/rectifier by replacing it with a known good unit.

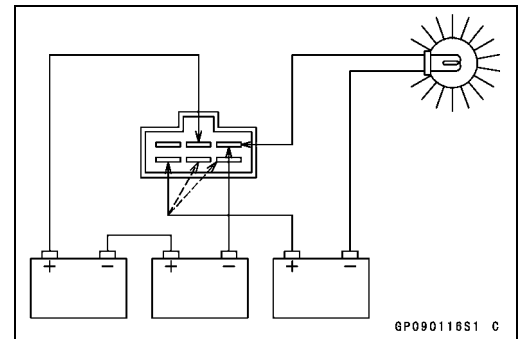
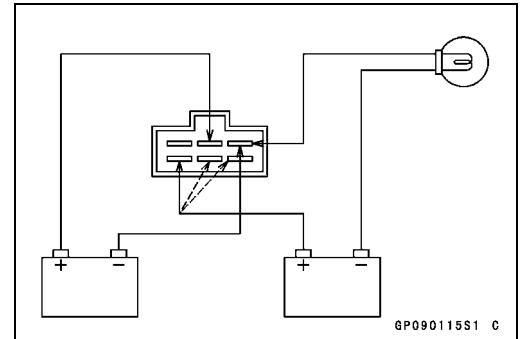
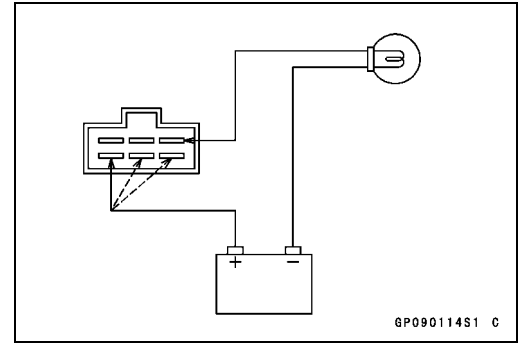

# 17-24 ELECTRICAL SYSTEM

## Charging System

### Charging System Circuit

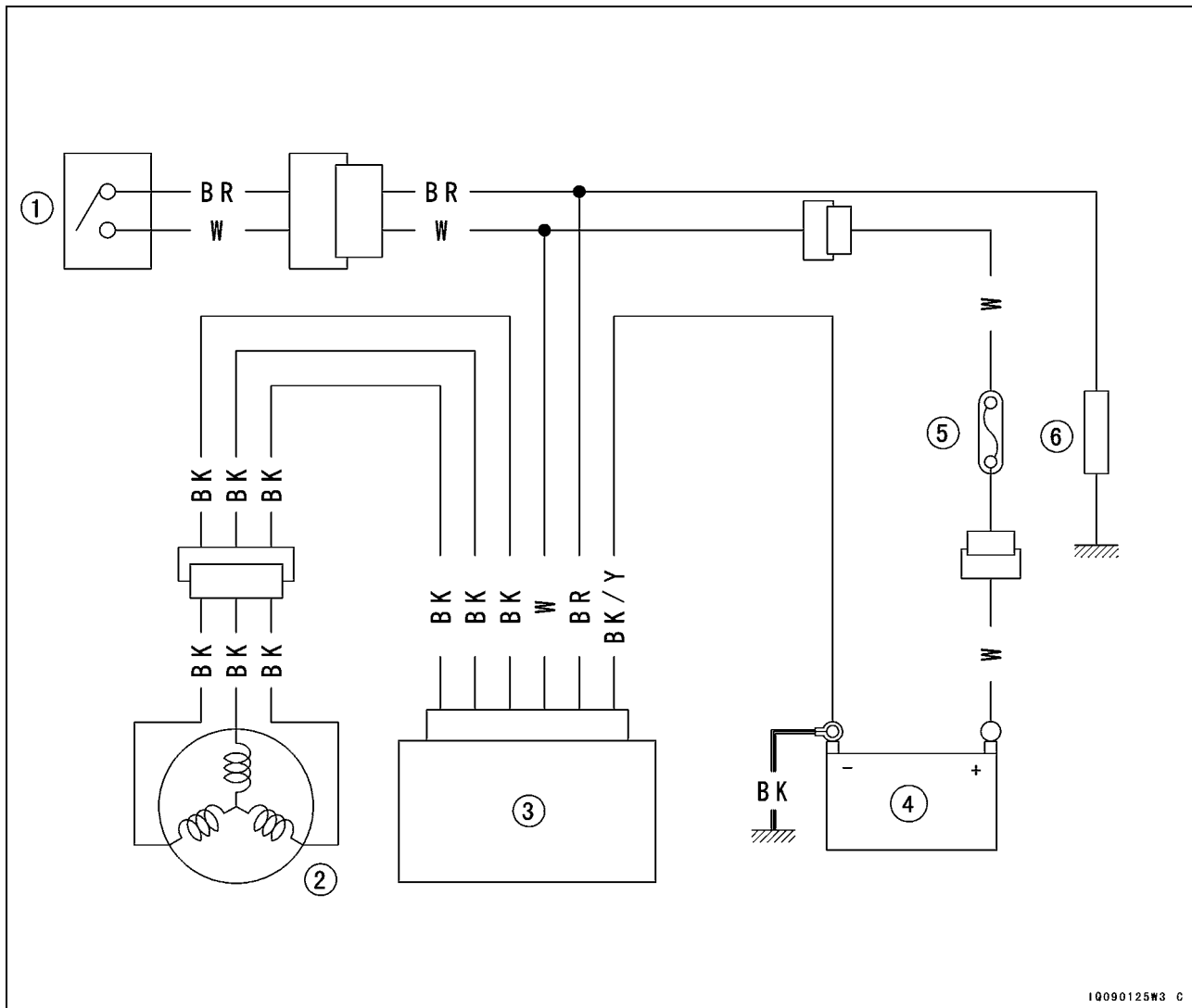

1. Ignition Switch
2. Alternator
3. Regulator/Rectifier
4. Battery
5. 30 A Fuse
6. Load

## Ignition System

### **⚠ WARNING**

The ignition system produces extremely high voltage. Do not touch the spark plug, high tension coil, or spark plug lead while the engine is running, or you could receive a severe electrical shock.

### **CAUTION**

Do not disconnect the battery leads or any other electrical connections when the ignition switch is on, or while the engine is running. This is to prevent IC igniter damage.

Do not install the battery backwards. The negative side is grounded. This is to prevent damage to the diodes and IC igniter.

### *Spark Plug Removal/Installation*

- Remove the spark plugs with a Hex. 19 long type socket wrench.
- Tighten:
  - Torque - Spark Plugs: 17 N·m (1.7 kgf·m, 12 ft·lb)**
- Fit the spark plug caps securely.
- Pull up the spark plug caps lightly to make sure of the installation of the spark plug caps.

### *Spark Plug Gap Inspection*

- Refer to Spark Plug Gap Inspection in the Periodic Maintenance chapter.

### *Spark Plug Cleaning/Inspection*

- Refer to Spark Plug Cleaning/Inspection in the Periodic Maintenance chapter.

### *Ignition Coil Removal*

- Remove:
  - Starter Motor (for rear ignition coil)
  - Ignition Coil Wires [A]
  - Ignition Coil Bolts [B]
  - Ignition Coil [C]

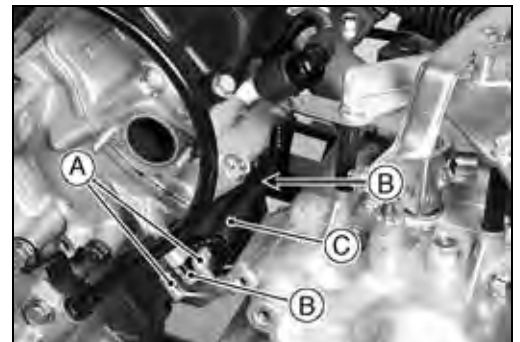

# 17-26 ELECTRICAL SYSTEM

## Ignition System

### Ignition Coil Installation

- Install:
  - Tube [A] (for rear ignition coil wire)



### Ignition Coil Inspection

- Measure the ignition coil [C] resistance.
  - Measure primary winding resistance [A]
  - Measure secondary winding resistance [B]

#### Ignition Coil Winding Resistance

Primary Winding: 1.87 ~ 2.53 Ω

Secondary Winding: 10.4 ~ 15.6 kΩ

- ★ If the meter does not read as specified, replace the coil.
- ★ If the meter reads as specified, the ignition coil windings are probably good. However, if the ignition system still does not perform as it should after all other components have been checked, test replace the coil with one known to be good.
- Check the spark plug wire for visible damage.
- ★ If the spark plug wire is damaged, replace the coil.

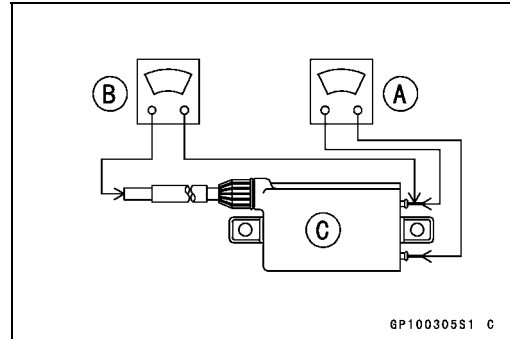

### Ignition Coil Primary Peak Voltage Inspection

#### NOTE

○ Be sure the battery is fully charged.

- Remove the spark plug cap, but do not remove the spark plug.
- Measure the primary peak voltage as follows.
  - Connect a commercially peak voltage adapter [A] to the hand tester [B] (250 V DC range), and install the needle adapter set [C] on the peak voltage adapter wire.

**Special Tools - Hand Tester: 57001-1394**

**Needle Adapter Set: 57001-1457**

**Peak Voltage Adapter: 57001-1415**

**Type: KEK-54-9-B**

**Brand: KOWA SEIKI**

- Insert the needle adapter inside the seal until the needle reaches the terminal in the connector [D].
- Install a new spark plug [E] into the spark plug cap, and ground it to the engine.
  - [F] Ignition Coil
  - [G] Igniter
  - [H] Battery

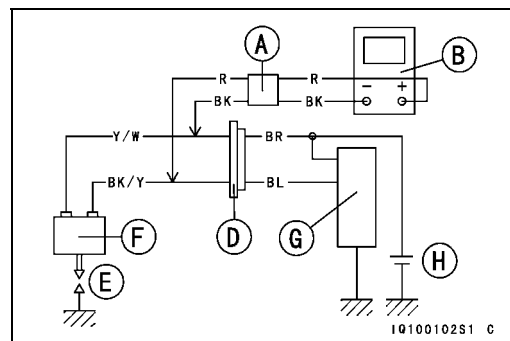
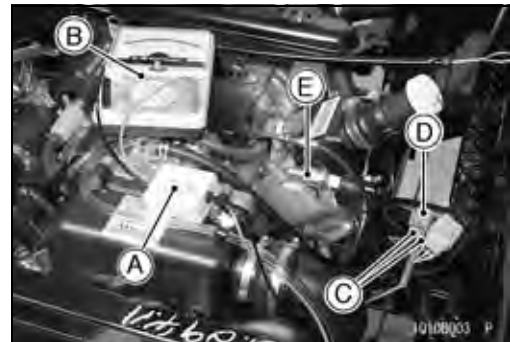

#### ⚠ WARNING

To avoid extremely high voltage shocks, do not touch the spark plugs or tester connections.

## Ignition System

- Turn the ignition switch ON, and run the engine 4 ~ 5 seconds with the transmission in neutral to measure the primary peak voltage.
- Repeat the measurements 5 times for one ignition coil.

### Ignition Coil Primary Peak Voltage

**Standard: 264 V or more**

- Repeat the test for the other ignition coil.
- ★ If the reading is less than the specified value, check the following.
  - Ignition Coils (see Ignition Coil Inspection)
  - Pickup Coil (see Pickup Coil Inspection)
- ★ If the ignition coils and pickup coil are normal, see the Ignition System Troubleshooting chart on page 16-24.

### Pickup Coil Removal

- Remove:
  - Alternator Cover (see Alternator Rotor and Stator Removal)
  - Pickup Coil Wire Connector [A]



- Remove:
  - Pickup Coil Screws [A]
  - Pickup Coil [B]



### Pickup Coil Inspection

- Disconnect the pickup coil wire connector [A].
- Measure the pickup coil resistance.

### Pickup Coil Resistance

**Standard: 88 ~ 132  $\Omega$**

- ★ If the resistance is not as specified, replace the pickup coil.

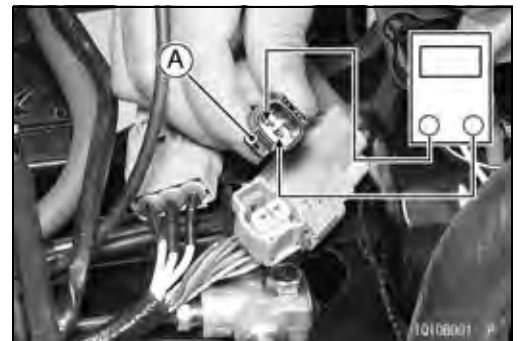

## 17-28 ELECTRICAL SYSTEM

### Ignition System

#### Pickup Coil Peak Voltage Inspection

##### NOTE

○Be sure the battery is fully charged.

- Remove the spark plug caps, but do not the spark plugs.
- Remove:
  - Pickup Coil Wire Connector [A]
- Set the hand tester [B] to the 10 V DC range.
- Connect the peak voltage adapter [C] to the hand tester and pickup coil wires in the connector.

**Special Tool - Hand Tester: 57001-1394**

**Peak Voltage Adapter: 57001-1415**

**Type: KEK-54-9-B**

**Brand: KOWA SEIKI**

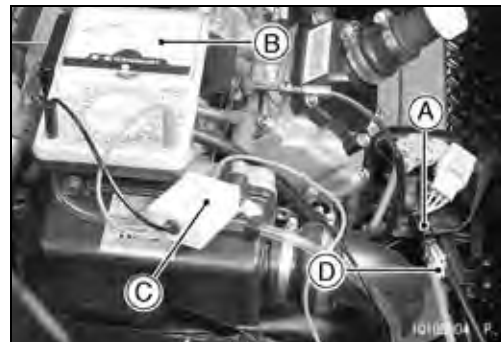

#### Connections

Crankshaft Sensor Wire		Adapter		Hand Tester
Yellow	←	Red	→	(+)
Green/White	←	Black	→	(-)

- Insert an insulator [D] between the wire clips to prevent a short.
- Turn the ignition switch on, and run the engine 4 ~ 5 seconds with the transmission gear in neutral to measure the pickup coil peak voltage.
- Repeat the measurement 5 or more times.

#### Pickup Coil Peak Voltage

**Standard: 4.5 V or more**

- ★ If the peak voltage is lower than the standard, inspect the pickup coil.

**Ignition System**

*Ignition System Inspection*

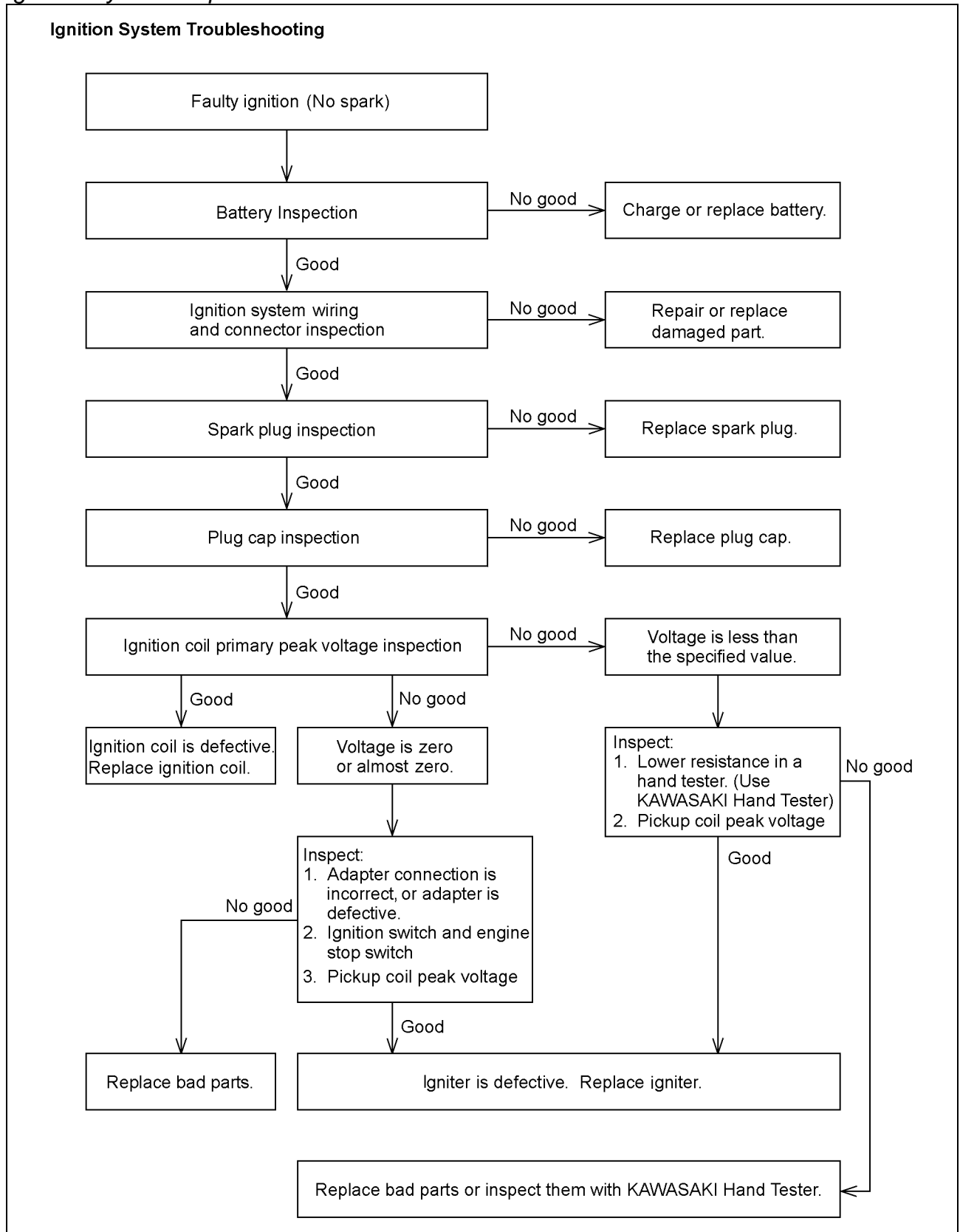

# 17-30 ELECTRICAL SYSTEM

## Ignition System

### Ignition System Circuit

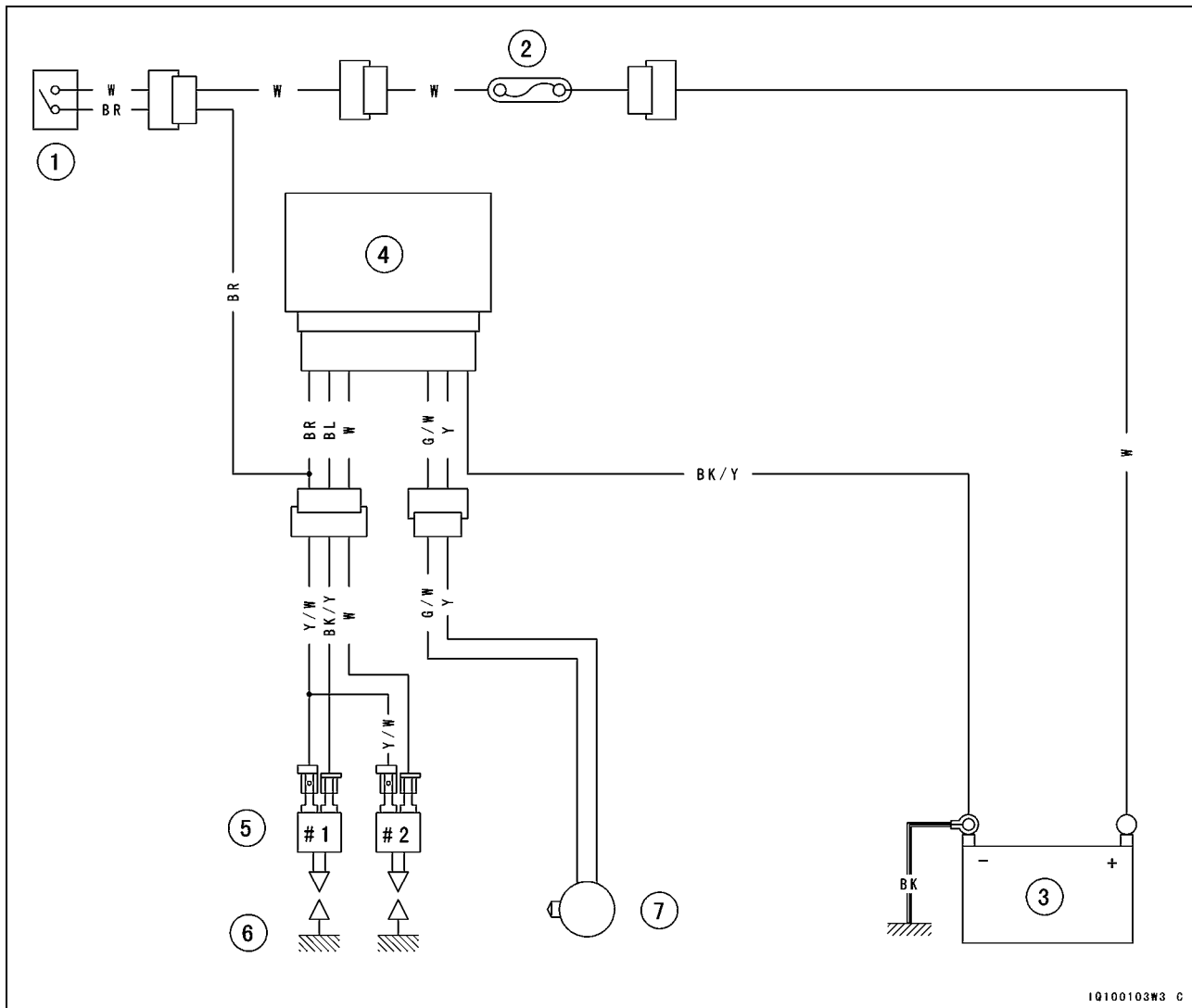

1Q100103M3 C

1. Ignition Switch
2. 30 A Fuse
3. Battery
4. Igniter
5. Ignition Coils
6. Spark Plugs
7. Pickup Coil



## Electric Starter System

### Starter Motor Removal

- Remove:
  - Torque Converter Case (see Converter System chapter)
  - Starter Motor Wires (from Starter Motor) [A]
  - Starter Motor Mounting Bolts [B]
  - Starter Motor [C]

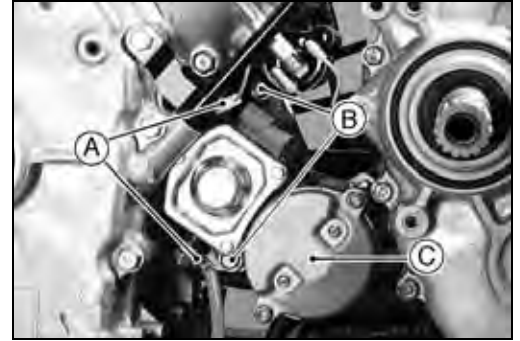

### Starter Motor Installation

- Clean the mating surface [A] of the starter motor and the crankcase where the starter motor is grounded [B].
- Install the starter motor and tighten the mounting bolts.
  - Torque - Starter Motor Mounting Bolts: 22 N·m (2.2 kgf·m, 16 ft·lb)**

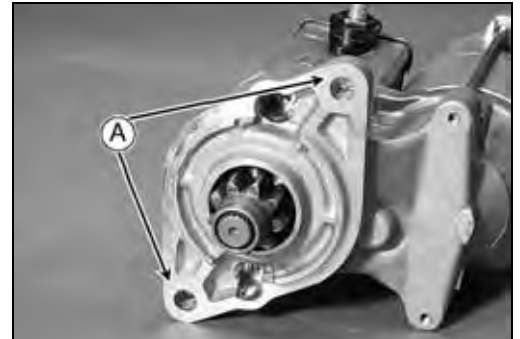

### Starter Motor Disassembly

- Remove:
  - Magnetic Switch Wire Nut [A]
  - Magnetic Switch Wire [B]
  - Starter Motor Through Bolts [C]
  - Yoke [D]

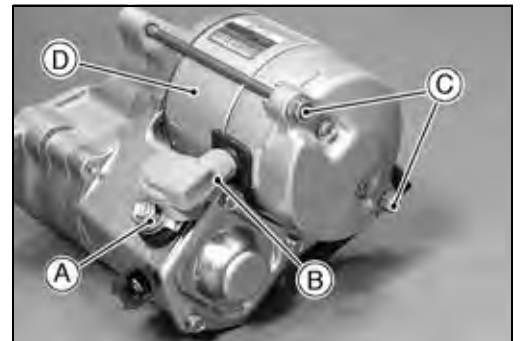

- Remove:
  - End Cover Screws [A]
  - End Cover [B]

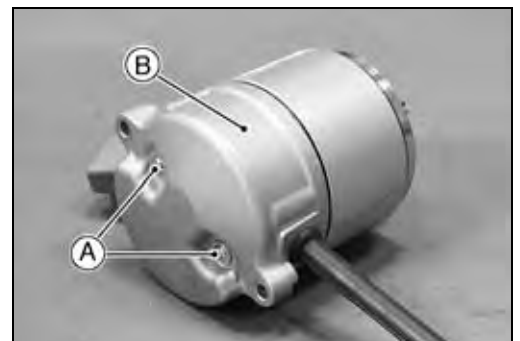

## 17-32 ELECTRICAL SYSTEM

### Electric Starter System

- Remove:  
Armature [A]  
Positive Brushes [B]  
Brush Plate [C]

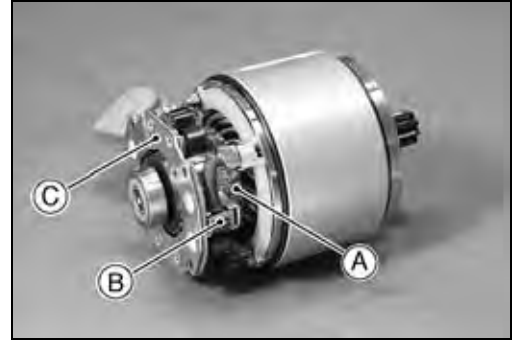

- Remove:  
Drive End Cover Screws [A]  
Drive End Cover [B]

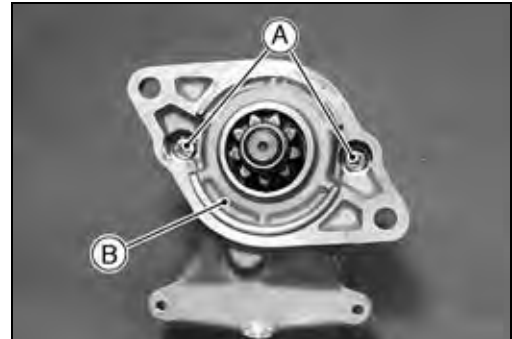

- Remove:  
Starter Clutch [A]  
Idle Gear [B]  
Steel Ball [C]

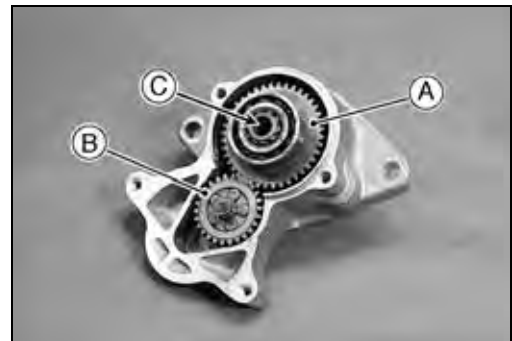

- Remove:  
Retainer [A] and Rollers [B]



- Remove:  
Return Spring [A]



## Electric Starter System

### Starter Motor Assembly

- Grease:
  - Retainer and Rollers
  - Starter Clutch
  - Steel Ball
  - Return Spring
  - Armature Bearing
- Install the retainer [A] and rollers [B] on the drive end cover shaft [C].

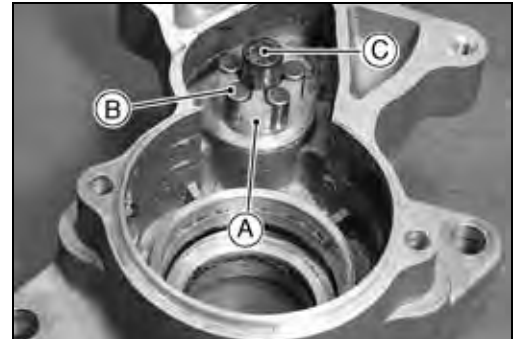

- Install:
  - Starter Clutch [A]
  - Idle Gear [B]

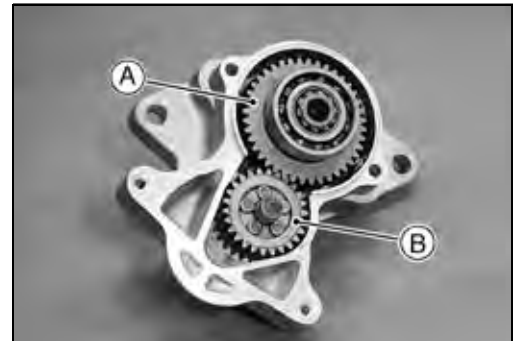

- Install:
  - Steel Ball
  - Return Spring
  - Drive End Cover and Screws

- Install the positive brushes [A] on the brush plate [B] with needle nose pliers.
- Pull the springs [C] and hold them with suitable plates [D] as shown.

- Install:
  - Armature

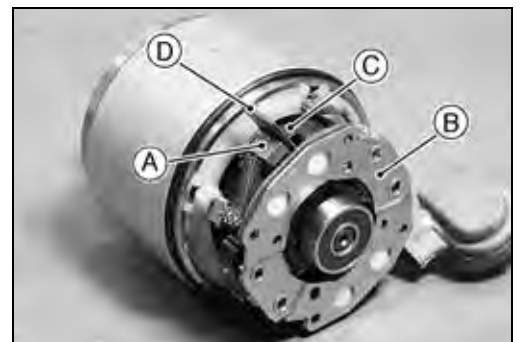

- Install:
  - End Cover

## 17-34 ELECTRICAL SYSTEM

### Electric Starter System

- Fit the projection [A] on the yoke [B] into the notch [C] in the magnetic switch [D].
- Install the magnetic switch wire and tighten the nut securely.

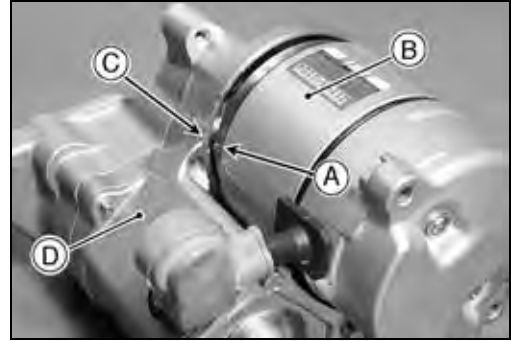

#### Carbon Brush Inspection

- Measure the carbon brush length [A].
- ★ If the brush length is less than the service limit, replace the brush assembly.

#### Carbon Brush Length

Standard: 15.5 mm (0.61 in.)

Service Limit: 8.5 mm (0.33 in.)

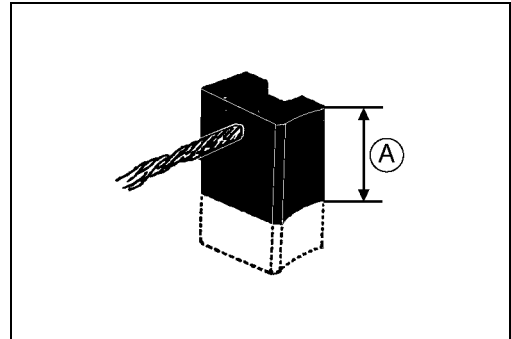

#### Yoke Inspection

- Measure the resistance between the carbon brush and the wire terminal [A].
- ★ If there is not close to 0  $\Omega$ , the field coils have an open. Replace the yoke.
- Measure the resistance between the carbon brush and the yoke body [B].
- ★ If there is any reading, the yoke has a short. Replace the yoke.

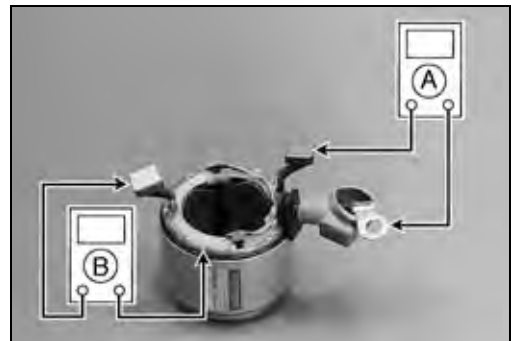

#### Brush Plate Inspection

- Measure the resistance between the carbon brush and the brush plate [A].
- ★ If there is not close to 0  $\Omega$ , the brush plate has an open. Replace the brush plate.
- Measure the resistance between the brush plate and the (+) brush holder [B].
- ★ If there is any reading, the brush plate has a short. Replace the brush plate.

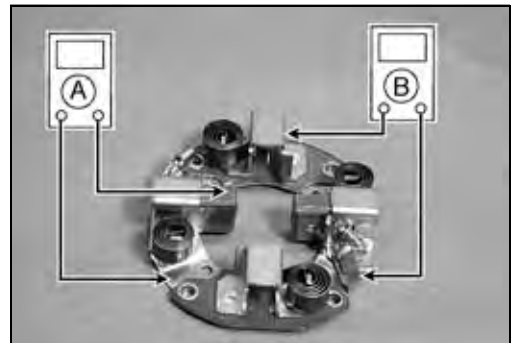

#### Commutator Cleaning/Inspection

- Smooth the commutator surface [A] if necessary with fine emery cloth [B], and clean out the grooves.

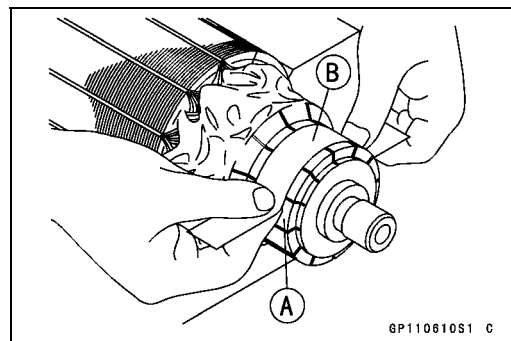

## Electric Starter System

- Measure the diameter [A] of the commutator.
- ★ Replace the starter motor with a new one if the commutator diameter is less than the service limit.

### Commutator Diameter

**Standard:** 30 mm (1.18 in.)

**Service Limit:** 29 mm (1.14 in.)

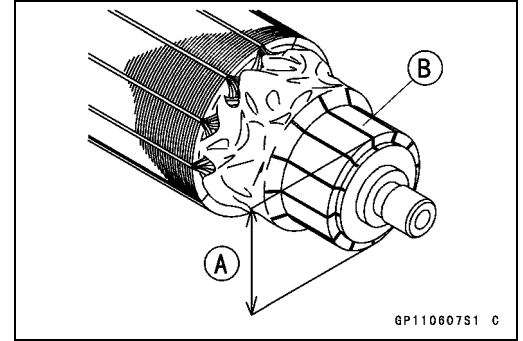

### Armature Inspection

- Using the  $\times 1 \Omega$  range of the hand tester, measure the resistance between any two commutator segments [A].
- ★ If there is a high resistance or no reading ( $\infty$ ) between any two segments, a winding is open. Replace the starter motor.
- Using the highest range of the hand tester, measure the resistance between the segments and the shaft [B].
- ★ If there is any reading at all, the armature has a short. Replace the starter motor.

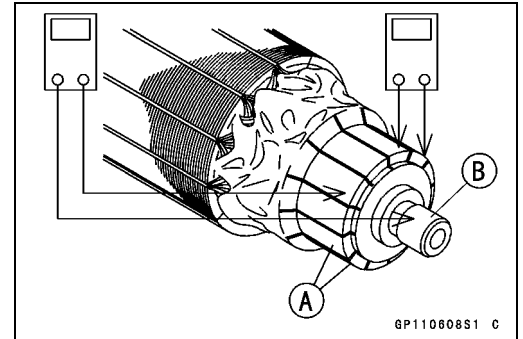

### NOTE

○ Even if the foregoing checks show the armature to be good, it may be defective in some manner not readily detectable with the hand tester. If all other starter motor and starter motor circuit components check good, but the starter motor still does not turn over or only turns over weakly, replace the starter motor with a new one.

### Pinion Gear Inspection

- Turn the pinion gear by hand. It should turn counterclockwise freely [A], but should not turn freely clockwise [B].
- ★ If the pinion gear does not operate as it should or if there is any worn or damaged part, replace it.



### Starter Switch Inspection

- Connect a 12 V battery to the starter switch [A] as shown.
- Connect the battery negative (-) wire [B] first and then the positive wire to the terminal in the connector [C].
- ★ If the switch does not work as specified, the switch is defective. Replace the starter switch.

### Testing Switch

**Criteria:** When battery is connected → Pinion gear must move outward quickly.

When battery is disconnected → Pinion gear must return quickly.

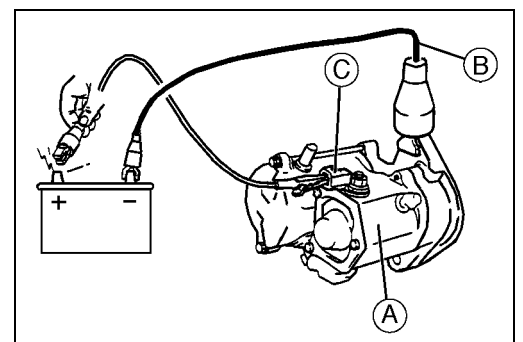

## 17-36 ELECTRICAL SYSTEM

### Electric Starter System

#### Starter Circuit Relay Inspection

- Remove:

- Starter Circuit Relay [A]

- Starter Circuit Relay Connector [B]

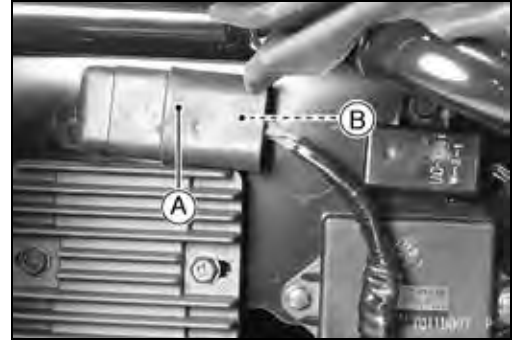

- Connect the hand tester [A] and 12 V battery [B] to the starter circuit relay [C] as shown.

- ★ If the relay does not work as specified, the relay is defective. Replace the relay.

#### Testing Relay

Hand Tester Range:  $\times 1 \Omega$

Criteria: When battery is connected  $\Rightarrow 0 \Omega$

When battery is disconnected  $\Rightarrow \infty \Omega$

Relay Coil Terminals [1] and [2]

Relay Switch Terminals [3] and [4]

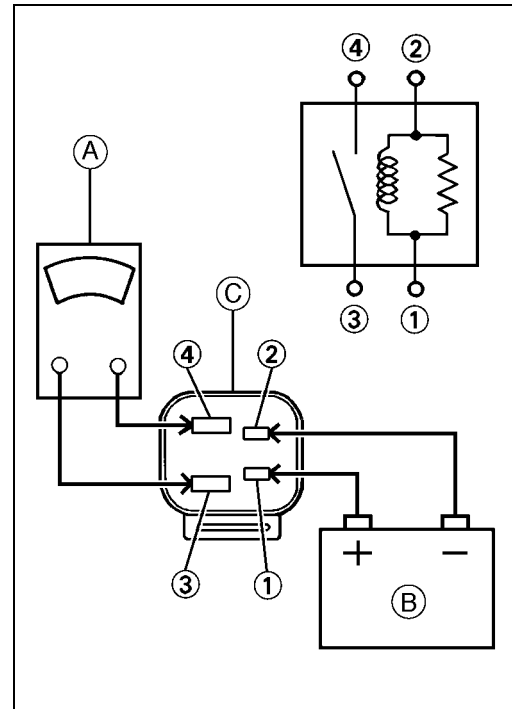

Electric Starter System

Electric Starter Circuit

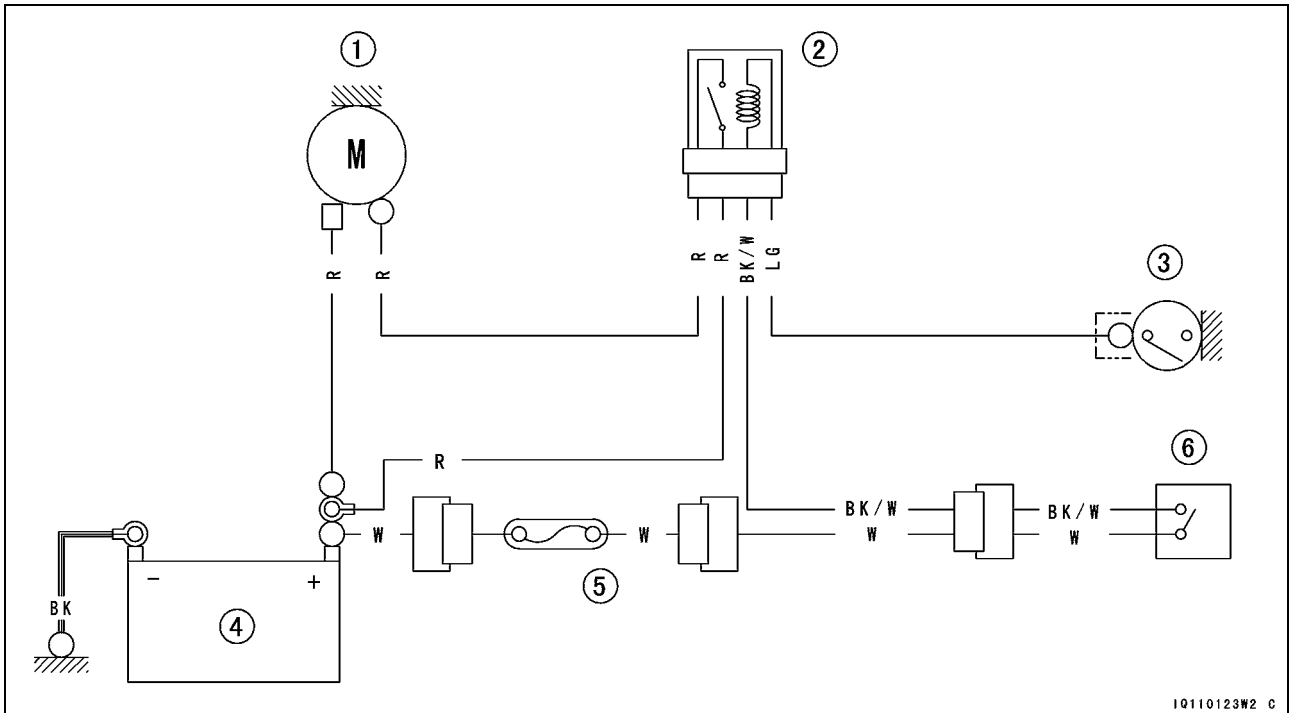

1. Starter Motor
2. Starter Circuit Relay
3. Neutral Switch
4. Battery
5. 30 A Fuse
6. Ignition Switch

1Q110123W2 C

# 17-38 ELECTRICAL SYSTEM

## Fuel Pump and Relay

The fuel pump does not operate when the ignition switch is turned on alone. The pump operates when the engine is running.

When fuel level in the float chamber is low, the fuel pump operates to supply fuel into the float chamber.

When the fuel reaches a certain level, the fuel pressure rises, and stops the fuel pump.

### Fuel Pump Operational Inspection

- Remove the fuel pump [A] and the fuel filter [B].
- Prepare a container filled with kerosene [C].
- Prepare the hoses, and connect them to the pump fittings.
- Connect the 12 V battery to the fuel pump leads.

#### Fuel Pump Leads

**BK/BL** → **Battery (+)**

**BK/Y** → **Battery (-)**

- ★ If the pump does not operate, the pump is defective.
- Close the outlet hose while operating the fuel pump.
- ★ If the pump does not stop, the pump is defective.

### Fuel Pump Relay Internal Resistance

- Measure the fuel pump relay [A] internal resistance shown in the table.

[B] Wires

- ★ If the measurements are not as specified, replace the relay.

#### Fuel Pump Relay Internal Resistance (Tester Range: × 1 kΩ)

Tester (-) Lead Connection	Tester (+) Lead Connection		
	BK/W	BL	BK/BL
BK/W	-	∞	∞
BL	∞	-	∞
BK/BL	∞	more than 10 kΩ	-

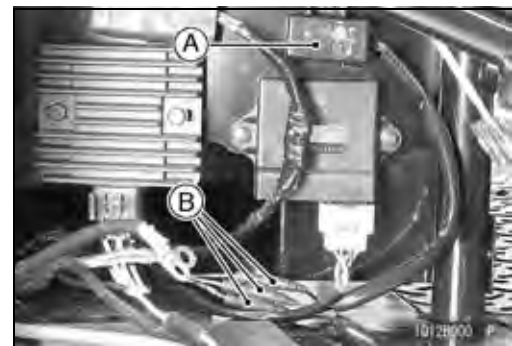
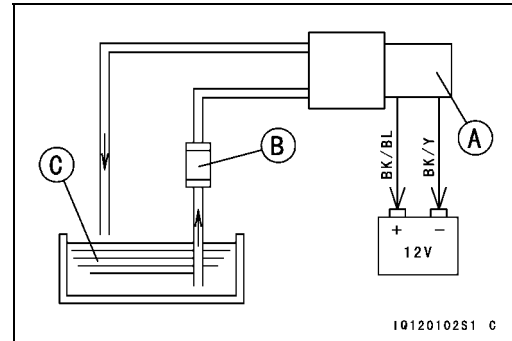



Fuel Pump and Relay

Fuel Pump and Relay Circuit

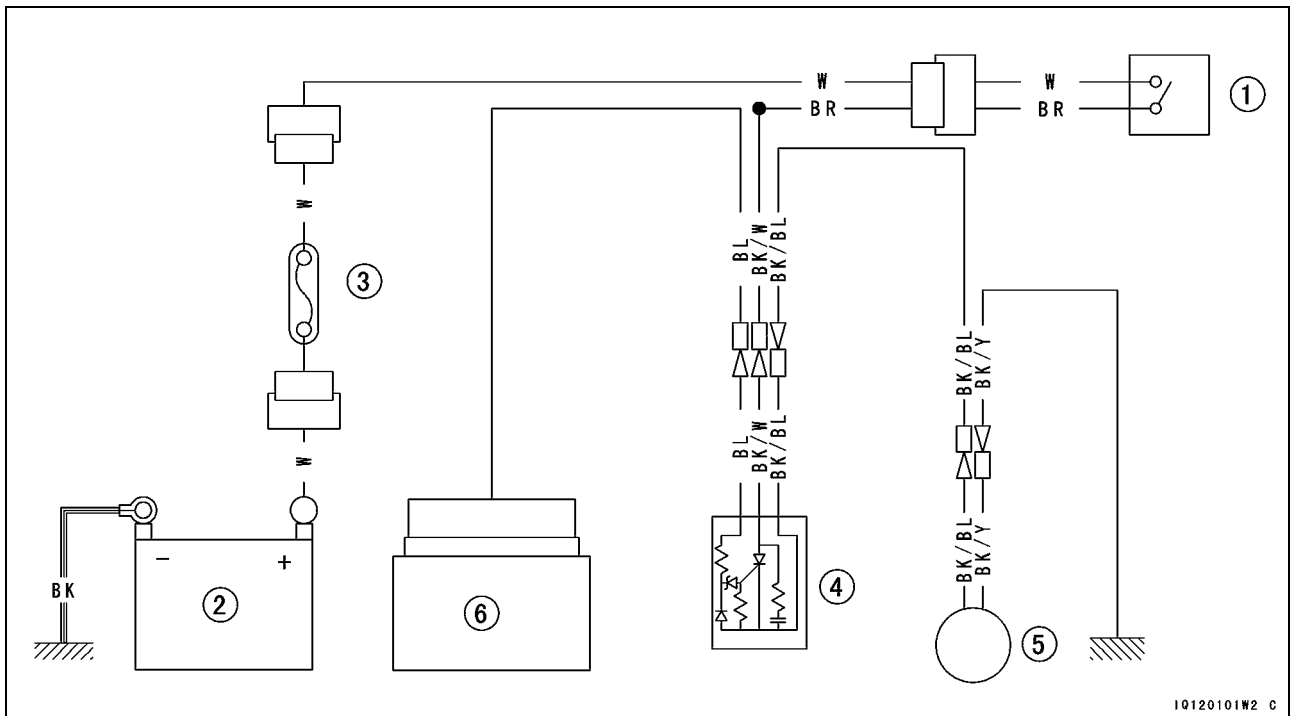

10120101W2 C

- 1. Ignition Switch
- 2. Battery
- 3. 30 A Fuse
- 4. Fuel Pump Relay
- 5. Fuel Pump
- 6. Igniter

# 17-40 ELECTRICAL SYSTEM

## Radiator Fan

### Radiator Fan Circuit Inspection

- Disconnect the wires from the radiator fan switch [A].
- Using an auxiliary wire [B], connect the radiator fan switch wires.
- ★ If the radiator fan rotates, inspect the radiator fan switch.
- ★ If the radiator fan does not rotate, inspect the following.
  - Wires and Connectors
  - Radiator Fan Fuse
  - Radiator Fan Motor

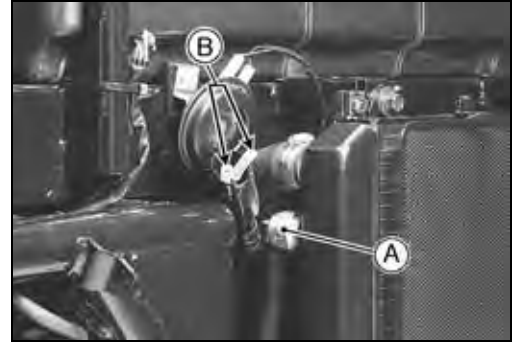

### Radiator Fan Motor Inspection

- Disconnect the fan motor wire connectors [A].
- Using two auxiliary wires, supply battery power to the fan motor.
- ★ If the fan does not rotate at this time, the fan motor is defective and must be replaced.

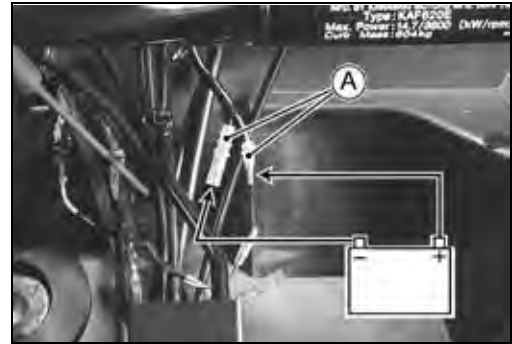

### Radiator Fan Motor Leads

**BL: Battery (+)**

**BK: Battery (-)**

- Repeat the above steps for the other radiator fan motor.

## Radiator Fan Circuit

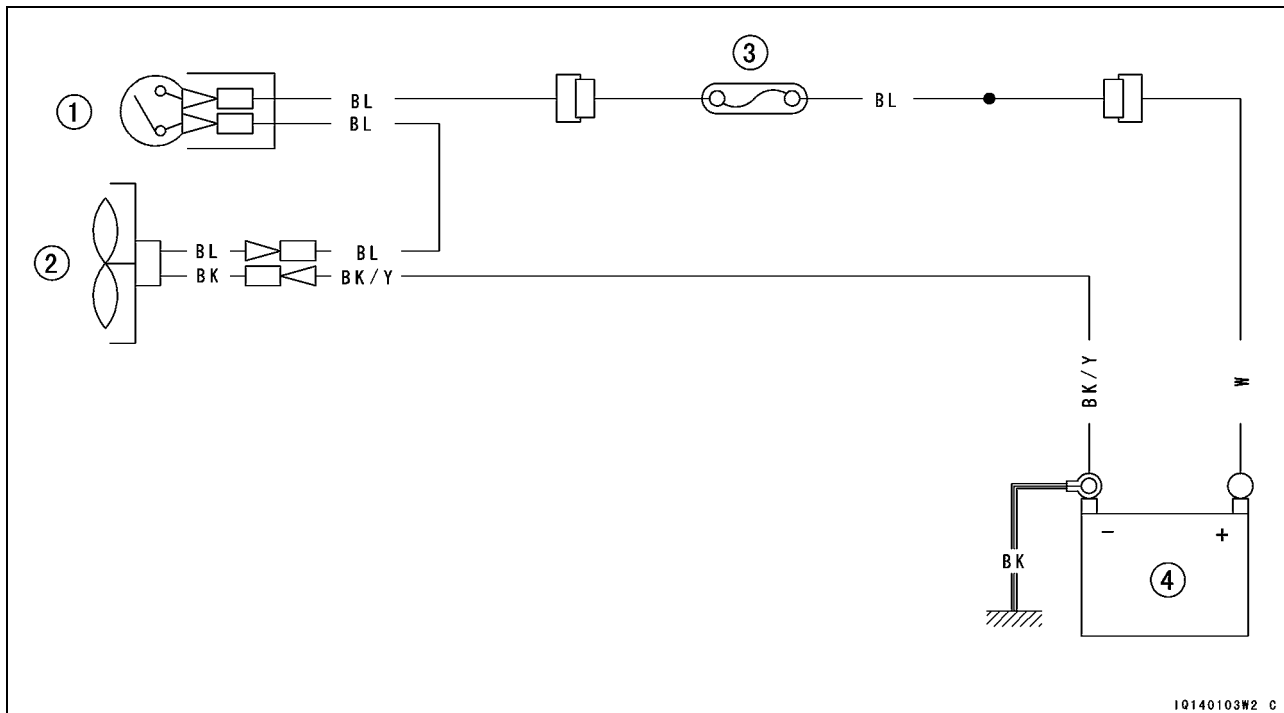

1. Radiator Fan Switch
2. Radiator Fan
3. 20 A Fuse
4. Battery

10140103W2 C

## Lighting System

### Headlight Beam Adjustment

- Turn the adjusting screw [A] on each headlight rim in or out to adjust the headlight vertically.



### Headlight Bulb Replacement

- Remove:
  - Front Cargo Bed Compartment (see Frame chapter)
  - Dust Cover [A]
- Turn the bulb holder [B] counterclockwise and remove it.

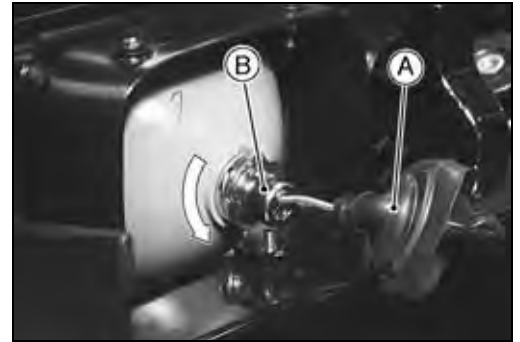

- Remove:
  - Headlight Bulb [A]

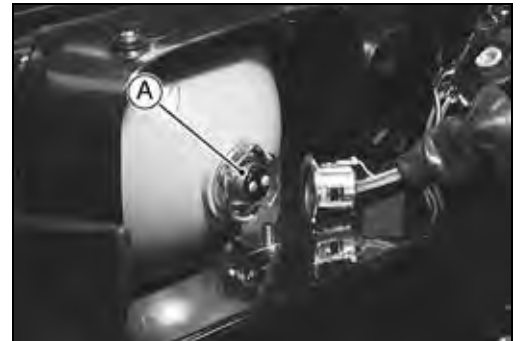

- Insert the new bulb [A] by aligning the tang [B] with the notch [C] in the headlight unit.

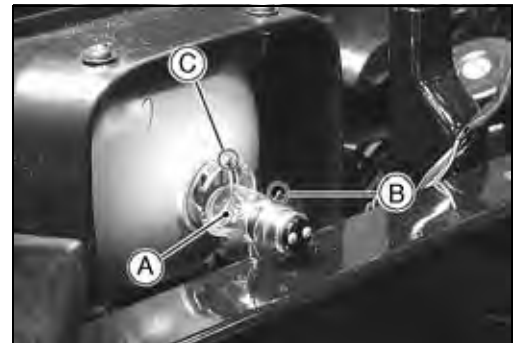

- Insert the bulb holder [A] by aligning the tangs [B] with the notches [C] in the headlight unit.
- Push the holder and turn it clockwise. It should lock in the position.
- Fit the dust cover completely.

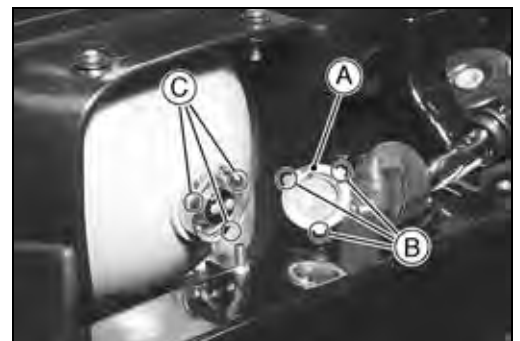

## 17-42 ELECTRICAL SYSTEM

### Lighting System

#### *Tail/Brake Light Replacement*

- Remove the lock pin type bulb [A].
- Remove the tail/brake light lens.
- Push the bulb in, turn it counterclockwise, and pull it out of the socket.

<b>CAUTION</b>
----------------

<b>Do not use bulbs rated for greater wattage than the specified value.</b>
---

- Be careful not to overtighten the lens mounting screws.



Lighting System

Lighting System Circuit

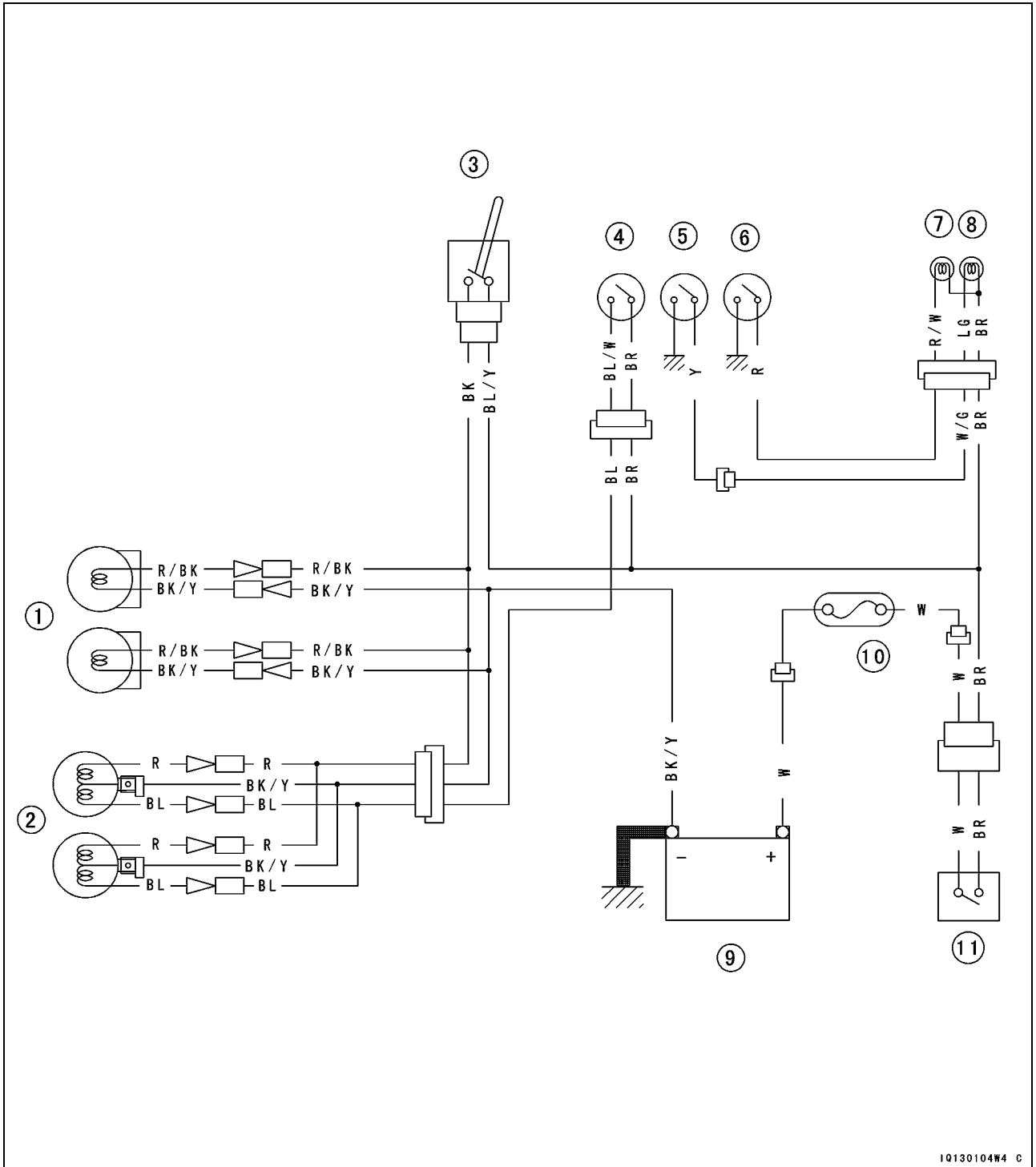

- 1. Headlights
- 2. Tail/Brake Lights
- 3. Light Switch
- 4. Brake Light Switch
- 5. Coolant Temperature Warning Light Switch
- 6. Parking Brake Light Switch
- 7. Parking Brake Indicator Light
- 8. Coolant Temperature Warning Indicator Light
- 9. Battery
- 10. 30 A Fuse
- 11. Ignition Switch

1Q130104W4 C

## 17-44 ELECTRICAL SYSTEM

### Switches

#### *Brake Light Switch Adjustment*

- Refer to Brake Light Switch Adjustment in the Periodic Maintenance chapter.

#### *Switch Inspection*

- Using a hand tester, check to see that only the connections shown in the table (see Wiring Diagram) have continuity (about zero ohms).
- ★ If the switch has an open or short, repair it or replace it with a new one.

#### *Radiator Fan Switch Inspection*

- Remove:  
Radiator Fan Switch (see Cooling System chapter)
- Suspend the fan switch [A] in a container of coolant so that the temperature sensing projection and threaded portion are submerged.
- Suspend an accurate thermometer [B] in the coolant, so that the sensitive portions [C] are located in almost the same depth.

#### **NOTE**

- *The switch and thermometer must not touch the container sides or bottom.*
- Place the container over a source of heat and gradually raise the temperature of the coolant while stirring the coolant gently.
- Using the hand tester, measure the internal resistance of the switch across the terminals at the temperatures shown in the table.
- ★ If the hand tester does not show the specified values, replace the switch.

#### **Radiator Fan Switch Resistance**

- **Rising temperature:**  
From OFF to ON at 86 ~ 90°C (187 ~ 194°F)
- **Falling temperature:**  
From ON to OFF at 81 ~ 85°C (178 ~ 185°F)  
ON: Less than 0.5 Ω  
OFF: More than 1 MΩ
- Repeat the above steps for the other fan switch.

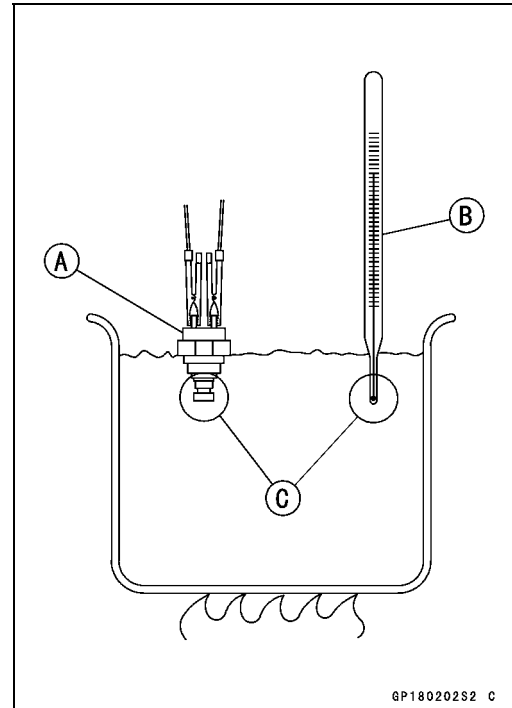

## Switches

### Coolant Temperature Warning Light Switch Inspection

- Remove:  
Coolant Temperature Warning Light Switch (see Cooling System chapter)
- Suspend the switch [A] in a container of coolant so that the temperature sensing projection and threaded portion are submerged.
- Suspend an accurate thermometer [B] in the coolant, so that the sensitive portions [C] are located in almost in the same depth.

#### NOTE

- *The switch and thermometer must not touch the container sides or bottom.*
- Place the container over a source of heat and gradually raise the temperature of the coolant while stirring the coolant gently.
- Using the hand tester, measure the internal resistance of the switch across the connector and the body at the temperatures shown in the table.
- ★ If the hand tester does not show the specified values, replace the switch.

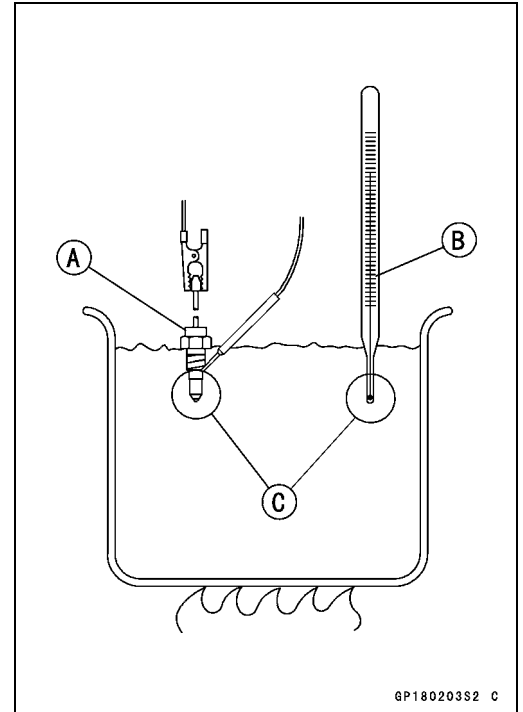

GP180203S2 C

### Coolant Temperature Warning Light Switch Resistance

- **Rising temperature:**  
From OFF to ON at 108 ~ 114°C (226 ~ 237°F)
- **Falling temperature:**  
From ON to OFF within 7°C (45°F) of "ON" temperature
  - ON: Less than 0.5 Ω
  - OFF: More than 1 MΩ

## 17-46 ELECTRICAL SYSTEM

### Fuses

#### Fuse Removal

- Unlock the hook to lift up the lid [A].
- Pull the fuses [B] straight out of the fuse box with a needle nose pliers.

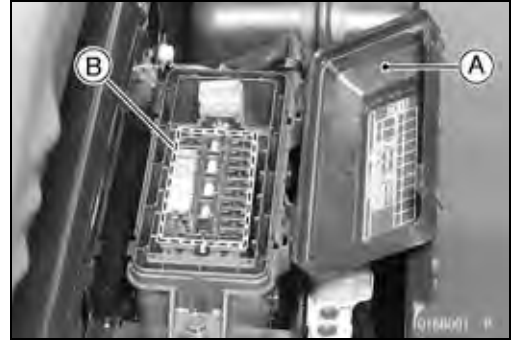

#### Fuse Installation

- ★ If a fuse fails during operation, inspect the electrical system to determine the cause, and then replace it with a new fuse of proper amperage.
- Install the fuse box fuses on the original position as specified on the lid.

#### Fuse Inspection

- Remove the fuse.
- Inspect the fuse element.
- ★ If it is blown out, replace the fuse. Before replacing a blown fuse, always check the amperage in the affected circuit. If the amperage is equal to or greater than the fuse rating, check the wiring and related components for a short circuit.

Housing [A]  
Fuse Element [B]  
Terminals [C]  
Blown Element [D]

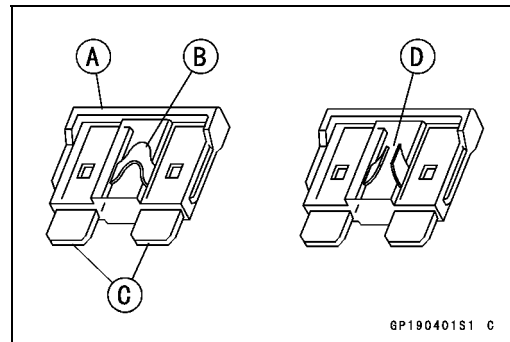

#### CAUTION

When replacing a fuse, be sure the new fuse matches the specified fuse rating for that circuit. Installation of a fuse with a higher rating may cause damage to wiring and components.



## Electrical Wiring

### *Wiring Inspection*

- Visually inspect the wiring for signs of burning, fraying, etc.
- ★ If any wiring is poor, replace the damaged wiring.
- Pull each connector [A] apart and inspect it for corrosion, dirt, and damage.
- ★ If the connector is corroded or dirty, clean it carefully. If it is damaged, replace it.
- Check the wiring for continuity.
  - Use the wiring diagram to find the ends of the wire which is suspected of being a problem.
  - Measure the resistance between the ends of the wires.
  - ★ If the resistance is not 0  $\Omega$ , the wire is defective. Replace the wire or the wiring harness if necessary.

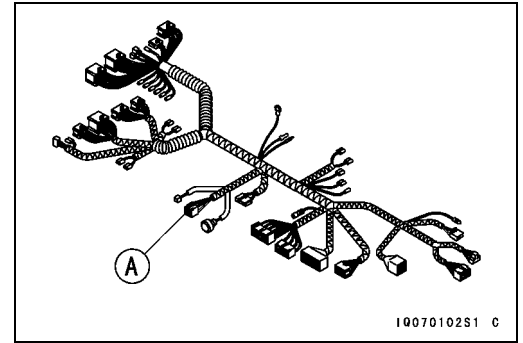

# 17-48 ELECTRICAL SYSTEM

## Wiring Diagram

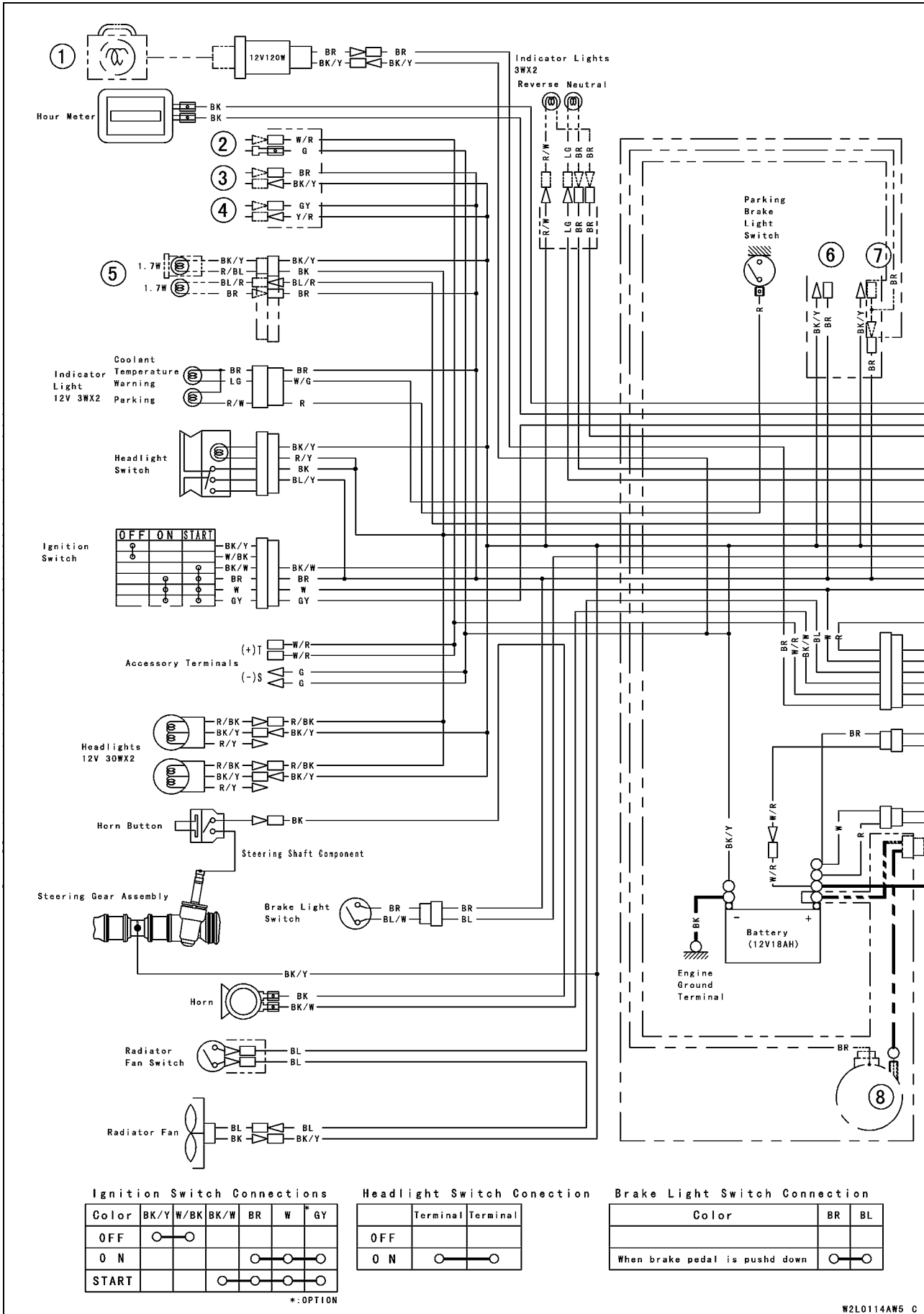

Ignition Switch Connections

Color	BK/Y	W/BK	BK/W	BR	W	GY
OFF	○	○				
ON				○	○	○
START				○	○	○

\*.OPTION

Headlight Switch Connection

	Terminal	Terminal
OFF		
ON	○	○

Brake Light Switch Connection

Color	BR	BL
When brake pedal is pushed down	○	○

## Wiring Diagram

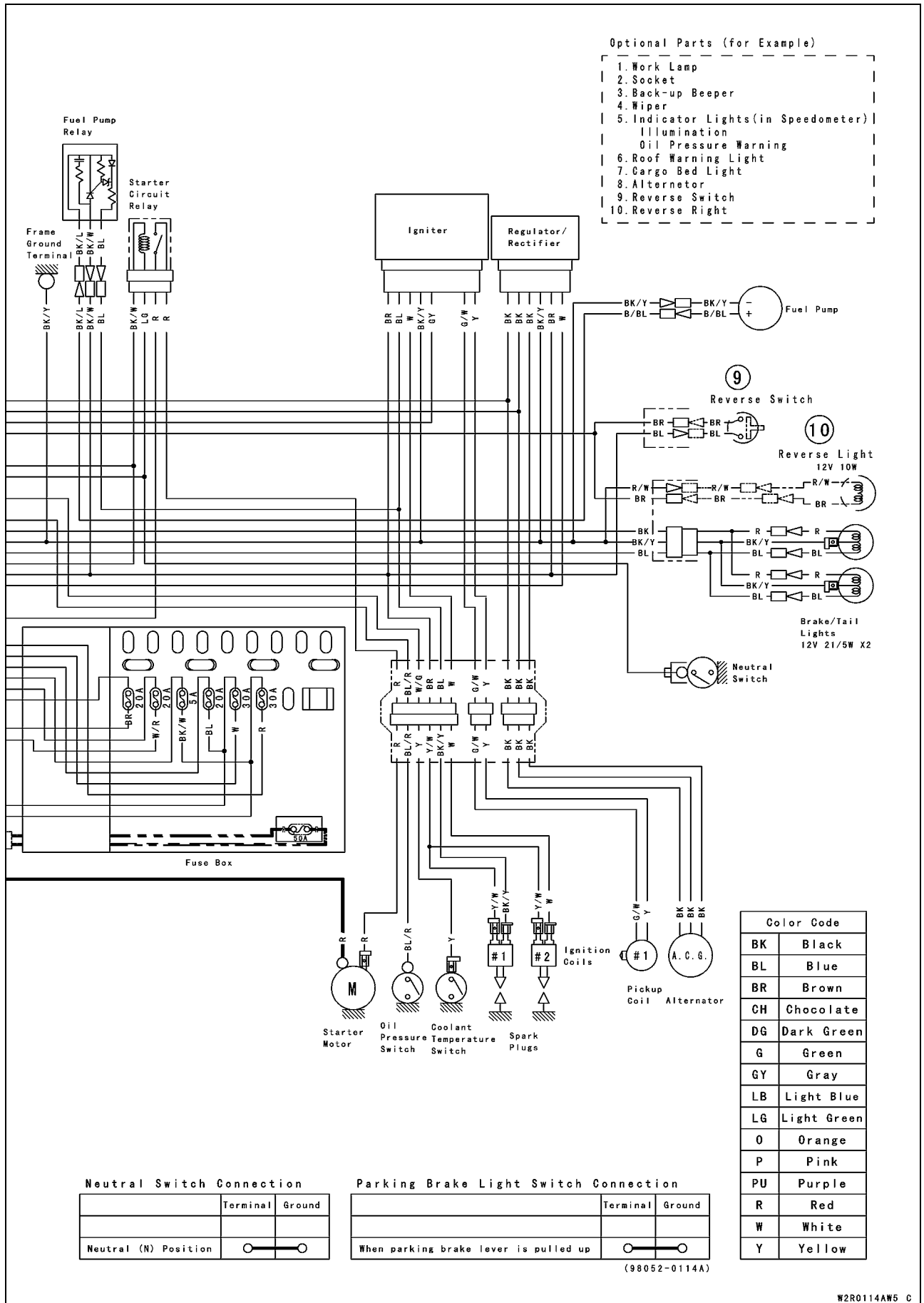



# Appendix

## Table of Contents

Troubleshooting Guide ..... 18-2  
Cable, Wire, and Hose Routing ..... 18-6

## 18-2 APPENDIX

### Troubleshooting Guide

---

#### NOTE

○ *This is not an exhaustive list, giving every possible cause for each problem listed. It is meant simply as a rough guide to assist the troubleshooting for some of the more common difficulties.*

#### Engine Doesn't Start, Starting Difficulty:

##### Starter motor not rotating:

- Neutral switch trouble
- Starter motor trouble
- Battery voltage low
- Relays not contacting or operating
- Wiring open or shorted
- Ignition switch trouble
- Fuse blown

##### Starter motor rotating but engine doesn't turn over:

- Starter motor trouble
- Pinion or ring gear worn

##### Engine won't turn over:

- Valve seizure
- Rocker arm seizure
- Cylinder, piston seizure
- Crankshaft seizure
- Connecting rod small end seizure
- Connecting rod big end seizure
- Camshaft seizure

##### No fuel flow:

- Fuel tank air vent obstructed
- Fuel pump trouble
- Fuel filter clogged
- Fuel line clogged
- Fuel pump relay trouble
- Float valve clogged

##### Engine flooded:

- Fuel level too high
- Float valve worn or stuck open
- Starting technique faulty  
(When flooded, crank the engine with the throttle fully opened to allow more air to reach the engine.)

##### No spark; spark weak:

- Spark plug dirty, broken, or maladjusted
- Spark plug cap or high tension wiring trouble
- Spark plug cap not in good contact
- Spark plug incorrect
- Igniter trouble
- Ignition coil trouble
- Pickup coil trouble
- Ignition switch shorted
- Wiring shorted or open
- Fuse blown

##### Compression Low:

- Spark plug loose

- Cylinder head not sufficiently tightened down

- No valve clearance

- Cylinder, piston worn

- Piston ring bad (worn, weak, broken, or sticking)

- Piston ring/groove clearance excessive

- Cylinder head gasket damaged

- Cylinder head warped

- Valve spring broken or weak

- Valve not seating properly (valve bent, worn, or carbon accumulation on the seating surface)

#### Poor Running at Low Speed:

##### Spark weak:

- Spark plug dirty, broken, or maladjusted

- Spark plug cap or high tension wiring trouble

- Spark plug cap shorted or not in good contact

- Spark plug incorrect

- Igniter trouble

- Ignition coil trouble

- Pickup coil trouble

##### Fuel/air mixture incorrect:

- Pilot screw maladjusted

- Pilot jet, or air passage clogged

- Air bleed pipe bleed holes clogged

- Air cleaner clogged, poorly sealed, or missing

- Choke valve stuck closed

- Fuel level too high or too low

- Fuel tank air vent obstructed

- Fuel pump trouble

- Governor link mechanism malfunctioning

##### Compression low:

- Spark plug loose

- Cylinder head not sufficiently tightened down

- No valve clearance

- Cylinder, piston worn

- Piston ring bad (worn, weak, broken, or sticking)

- Piston ring/groove clearance excessive

- Cylinder head warped

- Cylinder head gasket damaged

- Valve spring broken or weak

- Valve not seating properly (valve bent, worn, or carbon accumulation on the seating surface)

##### Other:

- Igniter trouble

- Engine oil viscosity too high

- Front final gear case oil viscosity too high (KAF620E)

- Five tail trouble

- Brake dragging

## Troubleshooting Guide

### Poor Running or No Power at High Speed:

#### Firing incorrect:

- Spark plug dirty, broken, or maladjusted
- Spark plug cap shorted or not in good contact
- Spark plug incorrect
- Igniter trouble
- Ignition coil trouble
- Pickup coil trouble

#### Fuel/air mixture incorrect:

- Choke valve stuck close
- Main jet clogged or wrong size
- Fuel level too high or too low
- Air cleaner clogged, poorly sealed, or missing
- Water or foreign matter in fuel
- Fuel tank air vent obstructed
- Fuel line clogged
- Fuel pump trouble
- Governor link mechanism malfunctioning

#### Compression low:

- Spark plug loose
- Cylinder head not sufficiently tightened down
- No valve clearance
- Cylinder, piston worn
- Piston ring bad (worn, weak, broken, or sticking)
- Piston ring/groove clearance excessive
- Cylinder head gasket damaged
- Cylinder head warped
- Valve spring broken or weak
- Valve not seating properly (valve bent, worn, or carbon accumulation on the seating surface.)

#### Knocking:

- Carbon built up in combustion chamber
- Fuel poor quality or incorrect
- Spark plug incorrect
- Igniter trouble

#### Miscellaneous:

- Throttle valve won't fully open
- Brake dragging
- Overheating
- Engine oil level too high
- Engine oil viscosity too high
- Front final gear case oil viscosity too high (KAF620E)
- Drive train trouble

### Overheating:

#### Firing incorrect:

- Spark plug dirty, broken, or maladjusted
- Spark plug incorrect
- Igniter trouble

#### Fuel/air mixture incorrect:

- Main jet clogged or wrong size
- Fuel level too low

Carburetor holder loose

Air cleaner clogged, poorly sealed, or missing

#### Compression high:

Carbon built up in combustion chamber

#### Engine load faulty:

- Engine oil level too high
- Engine oil viscosity too high
- Drive train trouble
- Brake dragging

#### Converter and/or belt excessive heating:

- Belt dirty or worn
- Drive or driven pulley sheave dirty or worn
- Driven pulley spring broken or weak
- Drive pulley spring broken or weak
- Idle speed too high
- Converter fan damaged

#### Lubrication inadequate:

- Engine oil level too low
- Engine oil poor quality or incorrect

#### Front final gear case overheating:

- Insufficient oil
- Bevel gears maladjusted
- LSD clutch maladjusted

#### Coolant incorrect:

- Coolant level too low
- Coolant deteriorated
- Thick coolant

#### Cooling system component incorrect:

- Radiator clogged
- Thermostat trouble
- Radiator cap trouble
- Radiator fan switch trouble
- Fan motor broken
- Fan blade damaged
- Water pump not turning
- Water pump impeller damaged

### Over Cooling

- Radiator fan switch trouble
- Thermostat trouble

### Converter Operation Faulty:

#### Belt slipping:

- Belt dirty or worn
- Drive or driven pulley sheave dirty or worn
- Drive pulley spring broken or weak

#### Converter engagement speed too low:

- Drive pulley spring broken or weak

#### Converter engagement speed too high:

- Belt dirty or worn
- Drive or driven pulley sheave dirty or worn
- Drive pulley weight doesn't move smoothly
- Drive pulley movable sheave doesn't move smoothly
- Drive or driven pulley movable sheave bush worn
- Drive pulley weight or roller worn

## 18-4 APPENDIX

### Troubleshooting Guide

---

#### **Shifting too quickly:**

- Drive pulley spring weak
- Driven pulley spring weak or incorrectly installed (too loose)

#### **Shifting too slowly:**

- Belt dirty or worn
- Drive or driven pulley sheave dirty or worn
- Drive pulley weight doesn't move smoothly
- Drive pulley movable sheave doesn't move smoothly
- Driven pulley spring incorrect installed (too tight)
- Driven pulley movable sheave doesn't move smoothly

#### **Gear Shifting Faulty:**

##### **Doesn't go into gear:**

- Shift arm bent or seized
- Gear stuck on the shaft
- Shift cable maladjusted
- Shift cable lubrication inadequate
- Shift cable damaged

##### **Jumps out of gear:**

- Shifter groove worn
- Gear dogs worn
- Shift arm positioning bolt spring weak or broken
- Shift block worn
- Transmission shaft, and/or gear splines worn
- Shift cable maladjusted

##### **Overshifts:**

- Shift arm positioning bolt spring weak or broken
- Shift cable maladjusted

#### **Abnormal Engine Noise:**

##### **Knocking:**

- Igniter trouble
- Carbon built up in combustion chamber
- Fuel poor quality or incorrect
- Spark plug incorrect
- Overheating

##### **Piston slap:**

- Cylinder/piston clearance excessive
- Cylinder, piston worn
- Connecting rod bent
- Piston pin, piston pin holes worn

##### **Valve noise:**

- Valve clearance incorrect
- Valve spring broken or weak
- Camshaft bearing worn
- Rocker arm push rod runout excessive

##### **Other noise:**

- Connecting rod small end clearance excessive
- Connecting rod big end clearance excessive
- Piston ring worn, broken or stuck

- Piston seizure or damaged
- Cylinder head gasket leaking
- Exhaust pipe leaking at cylinder head connection
- Crankshaft runout excessive
- Engine mounts loose
- Crankshaft bearing worn
- Loose alternator rotor

#### **Abnormal Drive Train Noise:**

##### **Converter noise:**

- Belt worn
- Drive or driven pulley sheave worn
- Drive or driven pulley movable sheave bush worn
- Drive or driven pulley mount loose
- Driven pulley shoe worn
- Drive pulley weight or roller side washer worn
- Drive pulley weight or roller worn

##### **Transmission noise:**

- Bearing worn
- Transmission gears worn or chipped
- Metal chips jammed in gear teeth
- Transmission oil insufficient

##### **Final drive noise:**

- Bearing worn
- Gears worn or chipped
- Metal chips jammed in gear teeth
- Insufficient lubricant
- Bevel gears maladjusted
- Worn LSD clutch friction plate
- Worn LSD clutch spring
- Universal joint damaged

#### **Abnormal Frame Noise:**

##### **Shock absorber noise:**

- Shock absorber damaged

##### **Brake noise:**

- Brake linings overworn or worn unevenly
- Drum worn unevenly or scored
- Brake spring(s) weak or broken
- Foreign matter in hub
- Brake not properly adjusted

##### **Other noise:**

- Bracket, nuts, bolts, etc. not properly mounted or tightened

#### **Exhaust Smokes Excessively:**

##### **White smoke:**

- Piston oil ring worn
- Cylinder worn
- Valve oil seal damaged
- Valve guide worn
- Engine oil level too high

##### **Black smoke:**

- Air cleaner clogged
- Main jet too large or fallen off
- Stuck valve stuck closed
- Fuel level too high



---

**Troubleshooting Guide**

---

**Brown smoke:**

- Main jet too small
- Fuel level too low
- Air cleaner poorly sealed or missing

**Handling and/or Stability Unsatisfactory:****Steering wheel hard to turn:**

- Steering shaft bearing damaged
- Steering shaft lubrication inadequate
- Steering shaft bent
- Steering gear assembly damaged
- Tire air pressure too low
- LSD clutch maladjusted

**Noise when turning:**

- Damaged side gear or pinion (front final gear case)
- Worn clutch friction plates (Front final gear case)
- Worn clutch spring (Front final gear case)

**Steering wheel shakes or excessively vibrates:**

- Tire(s) worn
- Suspension arm bushing worn
- Tie-rod joint worn
- Wheel rim warped
- Axle shaft bearing worn
- Steering wheel mount loose
- Steering bolt or nut loose

**Steering wheel pulls to one side:**

- Frame bent
- Wheel misalignment
- Suspension arm bent or twisted
- Steering shaft bent
- Steering gear assembly damaged
- Front or rear tire air pressure unbalanced
- Shock absorber unbalanced

**Shock absorption unsatisfactory:**

- (Too hard)
- Tire air pressure too high
- Shock absorber damaged
- (Too soft)
- Shock absorber oil leaking
- Shock absorber spring weak
- Tire air pressure too low

**Brake Doesn't Hold**

- Air in the brake line
- Brake fluid leak
- Brake fluid deteriorated
- Primary or secondary cup trouble
- Master or wheel cylinder scratched inside
- Brake not properly adjusted
- Lining overworn or worn unevenly
- Drum worn unevenly or scored
- Oil, grease on lining and drum
- Dirt, water between lining and drum
- Overheated brakes

**Battery Discharged:**

- Battery faulty (e.g., plates sulphated, shorted through sedimentation, electrolyte level too low)
- Battery leads making poor contact
- Load excessive (e.g., bulb of excessive wattage)
- Ignition switch trouble
- Regulator/Rectifier trouble
- Alternator trouble
- Wiring faulty

**Battery Overcharged:**

- Regulator/Rectifier trouble
- Battery trouble

## 18-6 APPENDIX

### Cable, Wire, and Hose Routing

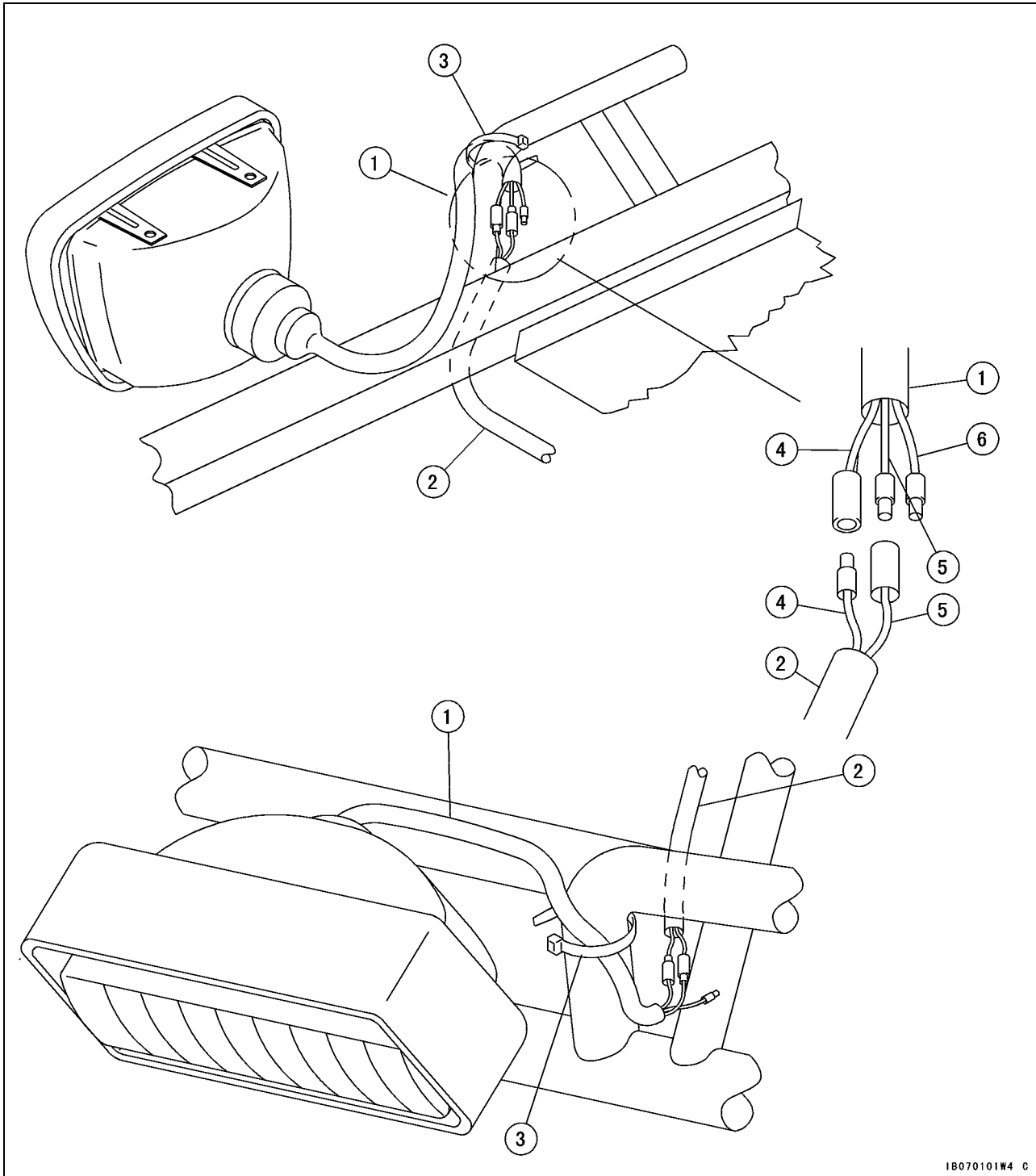

1. Headlight Wire
2. Main Harness
3. Band (Do not tighten band on wire connector joint.)
4. Black/Yellow Wire
5. Red/Black Wire
6. Red/Yellow Wire

Cable, Wire, and Hose Routing

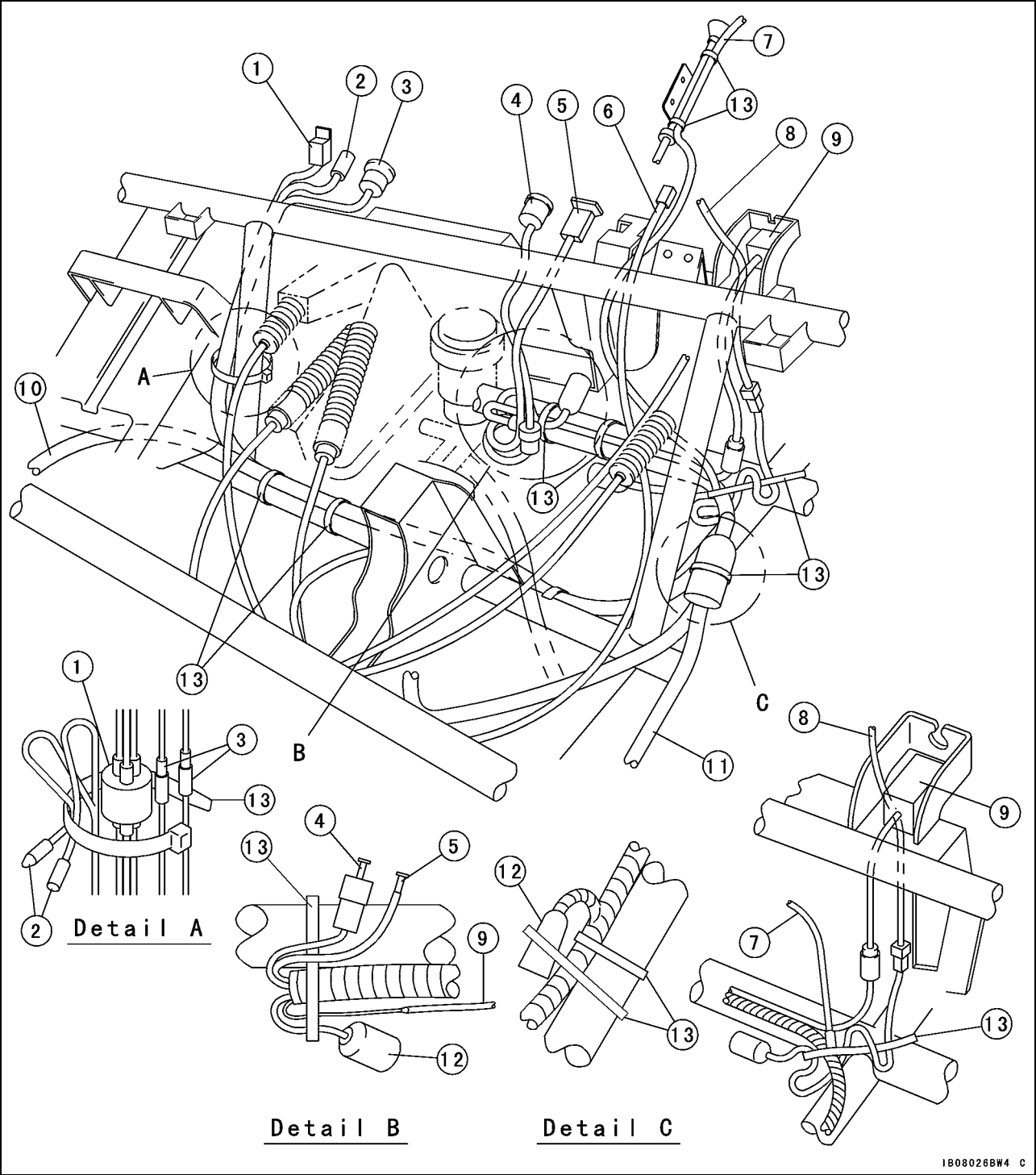

- 1. Water Temperature Warning/Parking Brake Indicator Lights
- 2. Oil Pressure Warning Indicator Light Wire (for Option)
- 3. Power Outlet Connector
- 4. Ignition Switch
- 5. Hour Meter
- 6. Speedometer Cable (Option)
- 7. Horn Switch Wire
- 8. Speedometer Light (Option)
- 9. Headlight Switch
- 10. Headlight Wire (Right)
- 11. Headlight Wire (Left)
- 12. Accessory Connector
- 13. Band

1B08026BW4 C

## 18-8 APPENDIX

### Cable, Wire, and Hose Routing

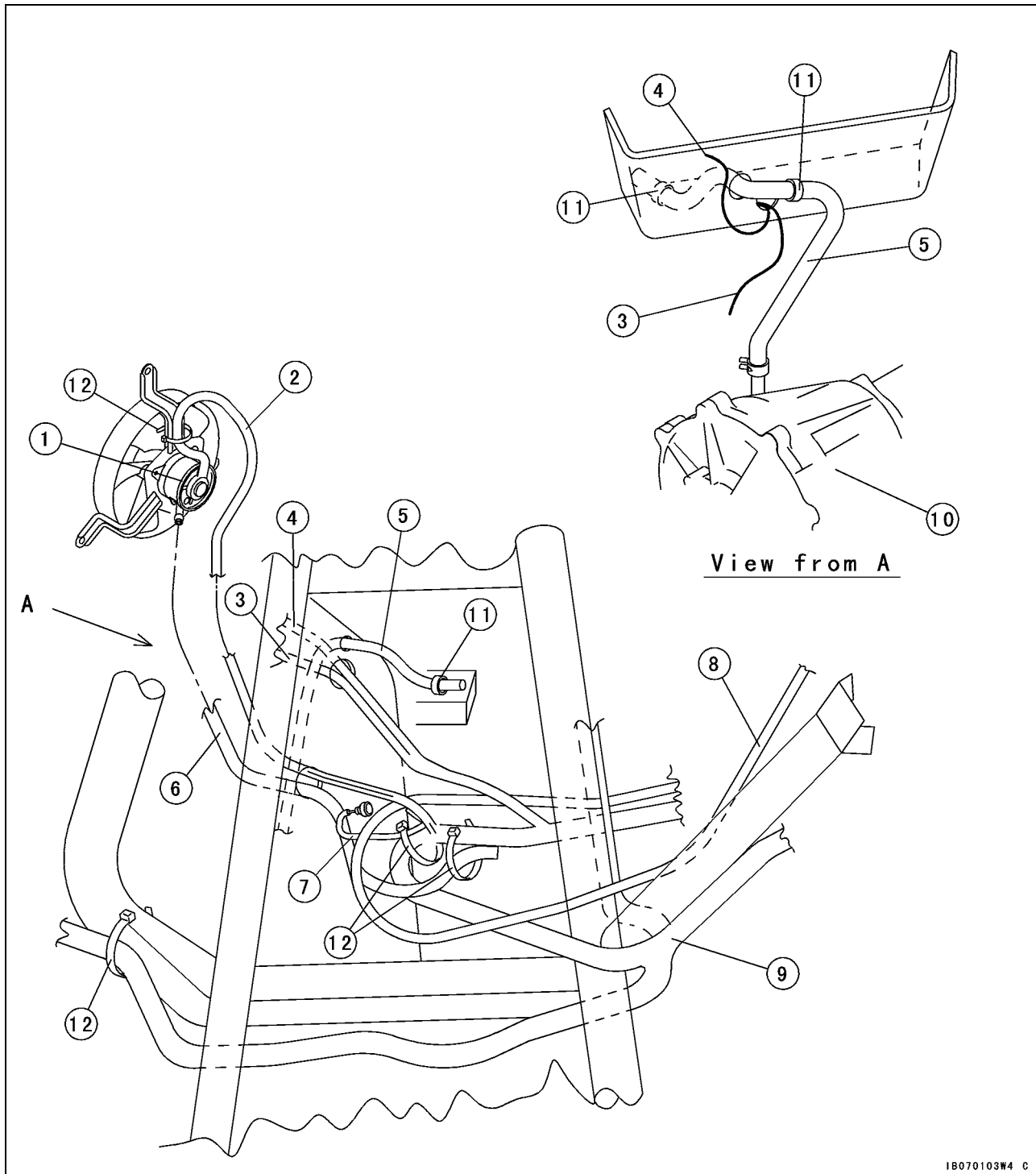

1. Radiator Fan Motor
2. Radiator Fan Motor Wire
3. Radiator Fan Switch
4. Horn Wire
5. Front Final Gear Case Breather Hose
6. Radiator Fan Motor Tube
7. Brake Light Switch
8. Speedometer Cable (Option)
9. Main Harness
10. Front Final Gear Case
11. Clamp
12. Band

Cable, Wire, and Hose Routing

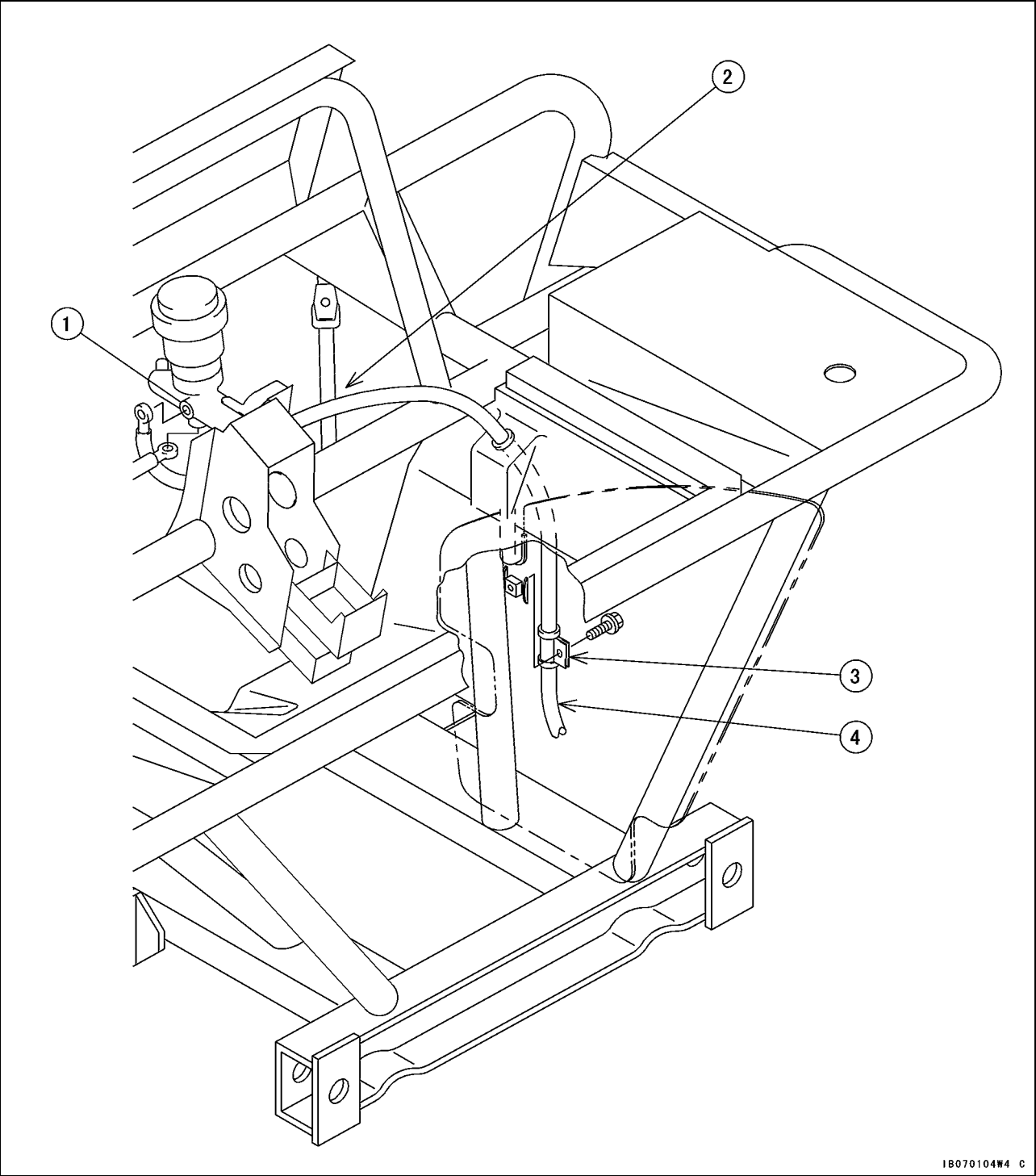

- 1. Brake Master Cylinder
- 2. Keep hose away from steering intermediate shaft.
- 3. Install clamp in this direction.
- 4. Brake Hose (Left)

# 18-10 APPENDIX

## Cable, Wire, and Hose Routing

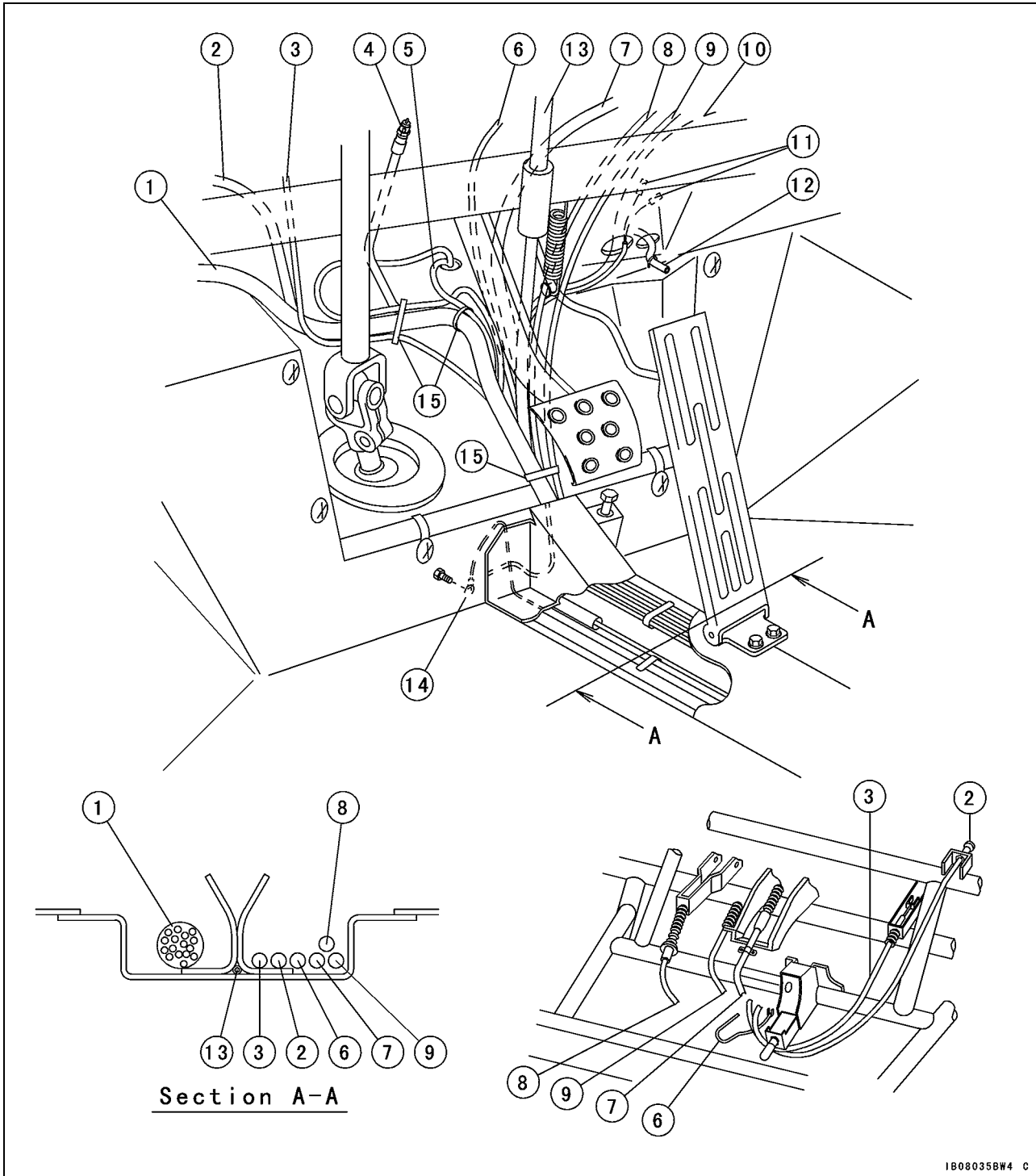

- |                             |   |
|-----------------------------|---|
| 1. Main Harness             | 9. Hi/Low Shift Cable                       |
| 2. Choke Cable              | 10. Radiator Fan Switch Wire                |
| 3. Differential Shift Cable | 11. Horn Wires                              |
| 4. Brake Light Switch       | 12. Front Final Gear Case Breather Hose     |
| 5. Radiator Fan Motor Tube  | 13. Brake Pipe                              |
| 6. Throttle Cable           | 14. Install wire on steering gear assembly. |
| 7. Transmission Shift Cable | 15. Band                                    |
| 8. 2WD/4WD Shift Cable      |   |

## Cable, Wire, and Hose Routing

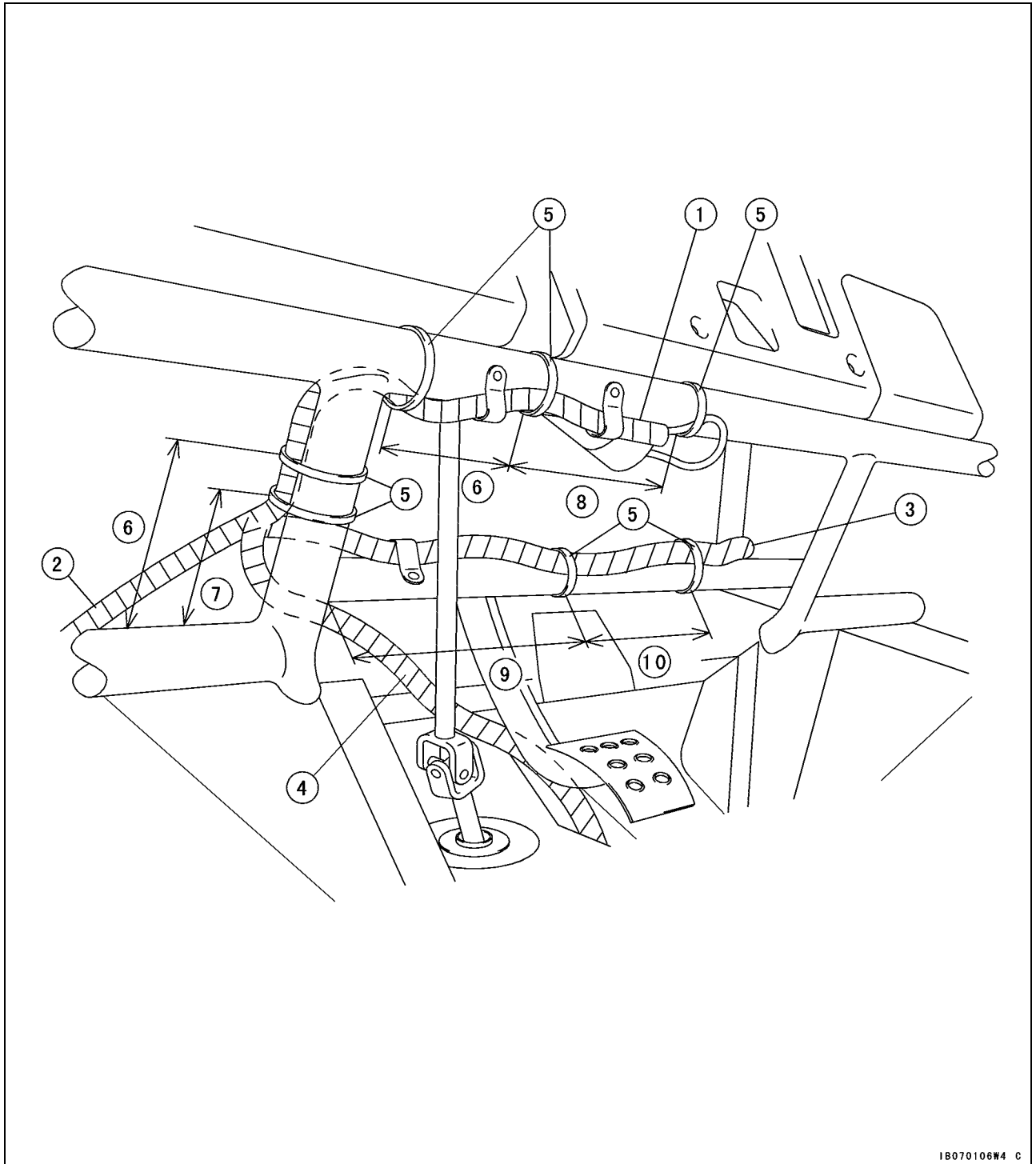

1. Ignition Switch Wire
2. Headlight Wire (Left)
3. Headlight Wire (Right)
4. Main Harness
5. Band
6. 110 mm (4.3 in.)
7. 80 mm (3.2 in.)
8. 170 mm (6.7 in.)
9. 300 mm (11.8 in.)
10. 140 mm (5.5 in.)

1B070106W4 C

## 18-12 APPENDIX

### Cable, Wire, and Hose Routing

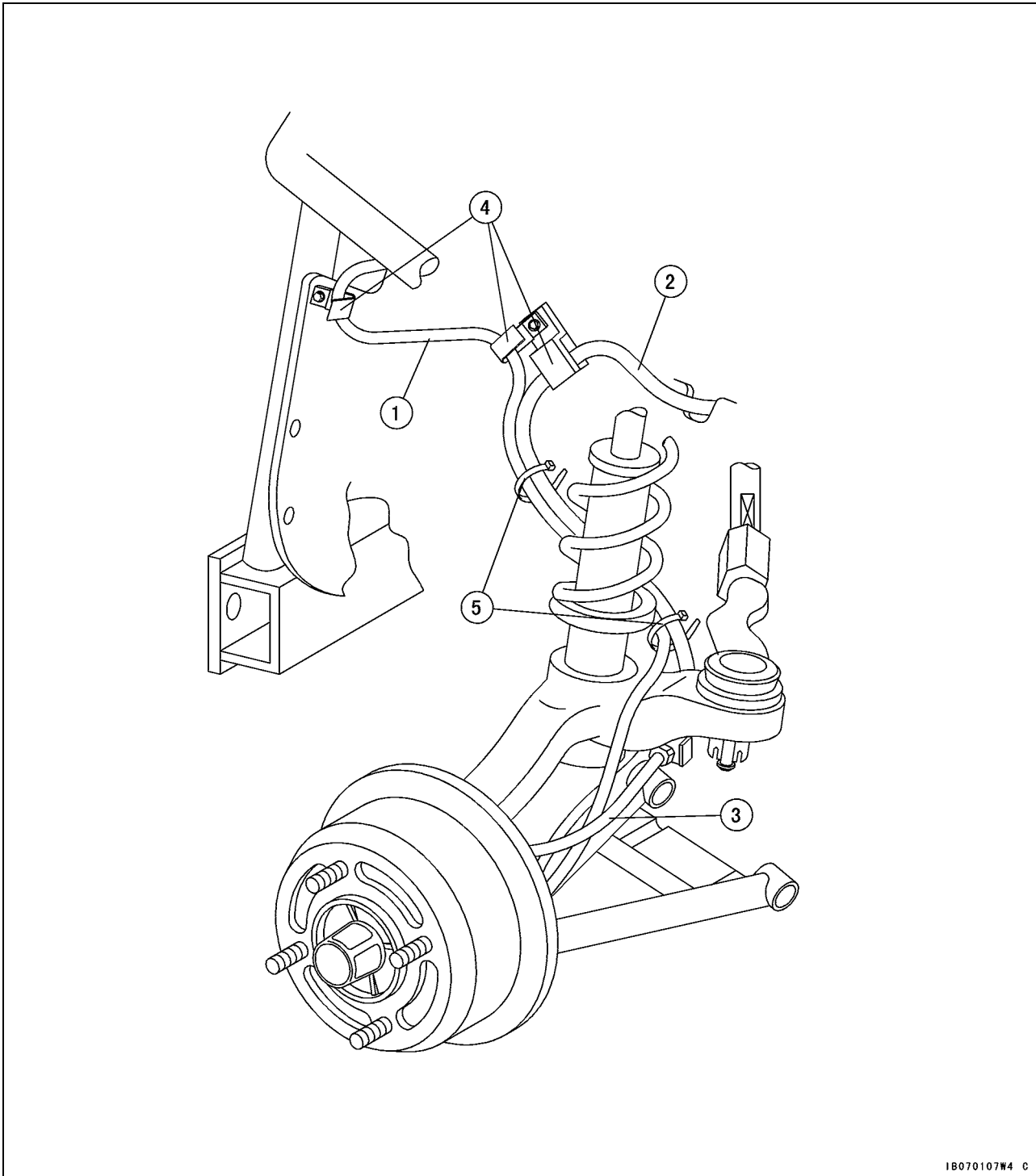

1. Breather Tube
2. Brake Hose
3. Brake Pipe
4. Clamp
5. Band



Cable, Wire, and Hose Routing

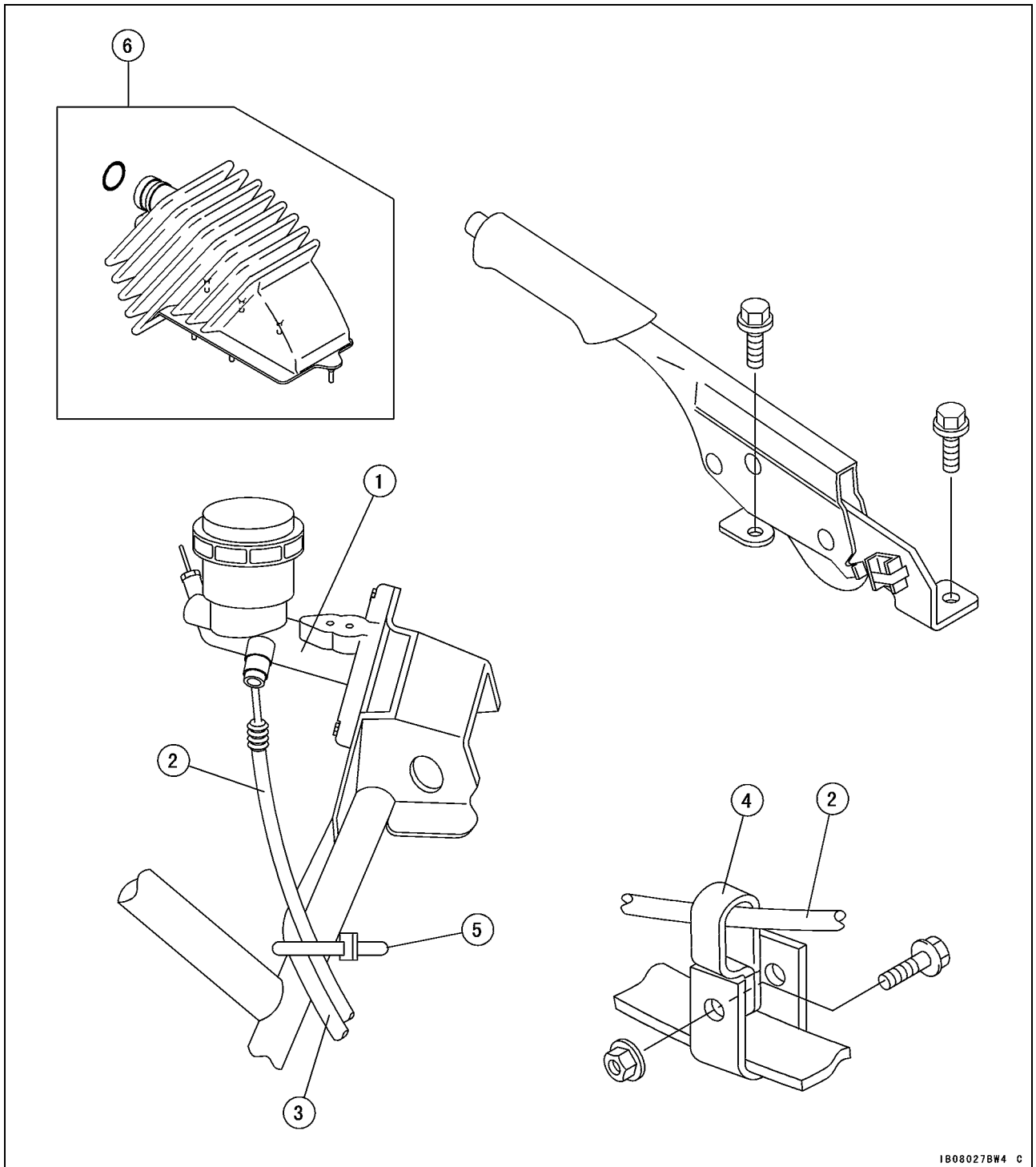

1B08027BW4 C

1. Front Brake Master Cylinder
2. Brake Hose
3. Harness
4. Clamp
5. Band
6. Parking Brake Lever Boot

## 18-14 APPENDIX

### Cable, Wire, and Hose Routing

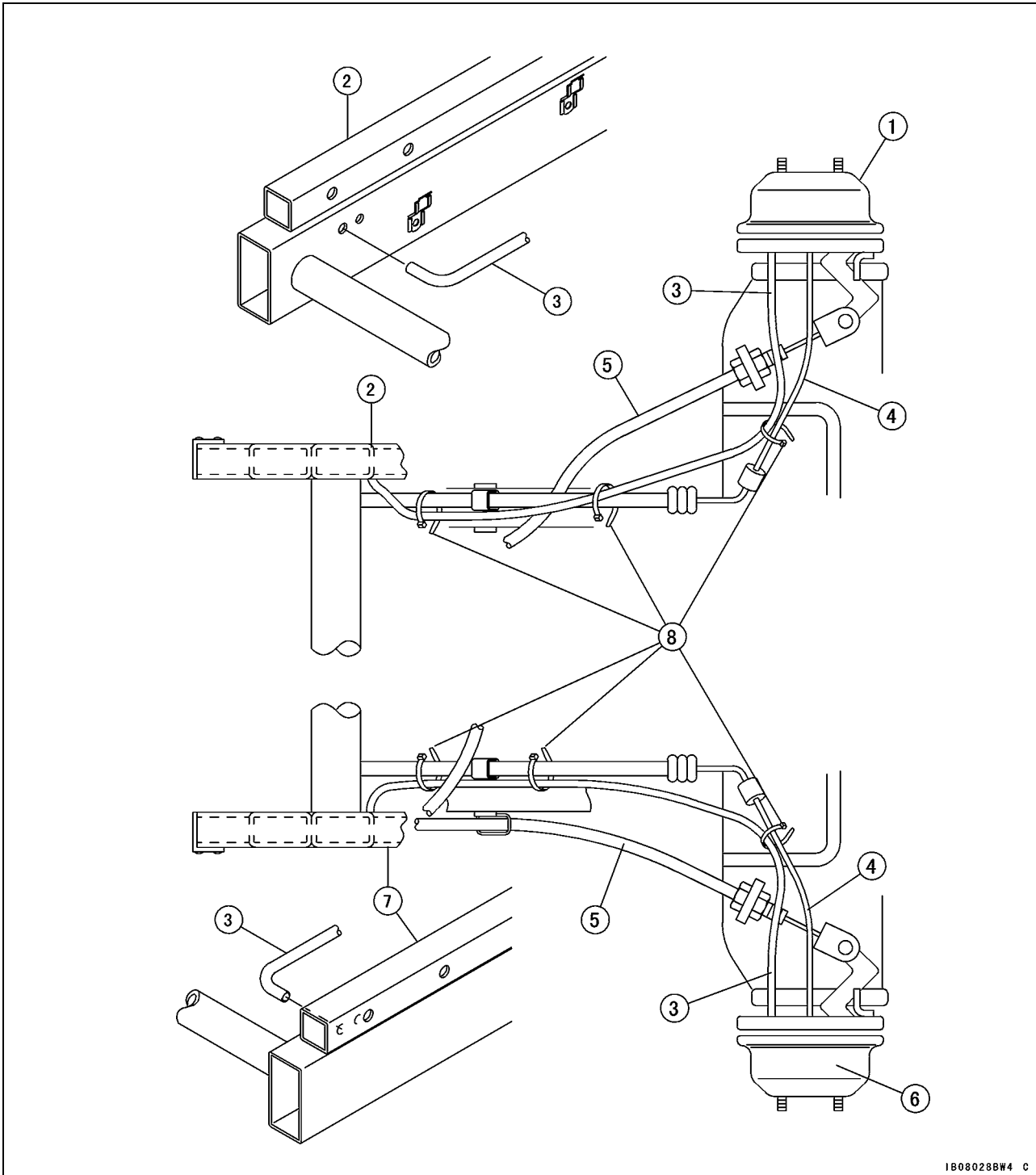

1B08028BW4 C

1. Right Brake Drum
2. Right Frame
3. Breather Tube
4. Brake Pipe
5. Brake Cable
6. Left Brake Drum
7. Left Frame
8. Band

Cable, Wire, and Hose Routing

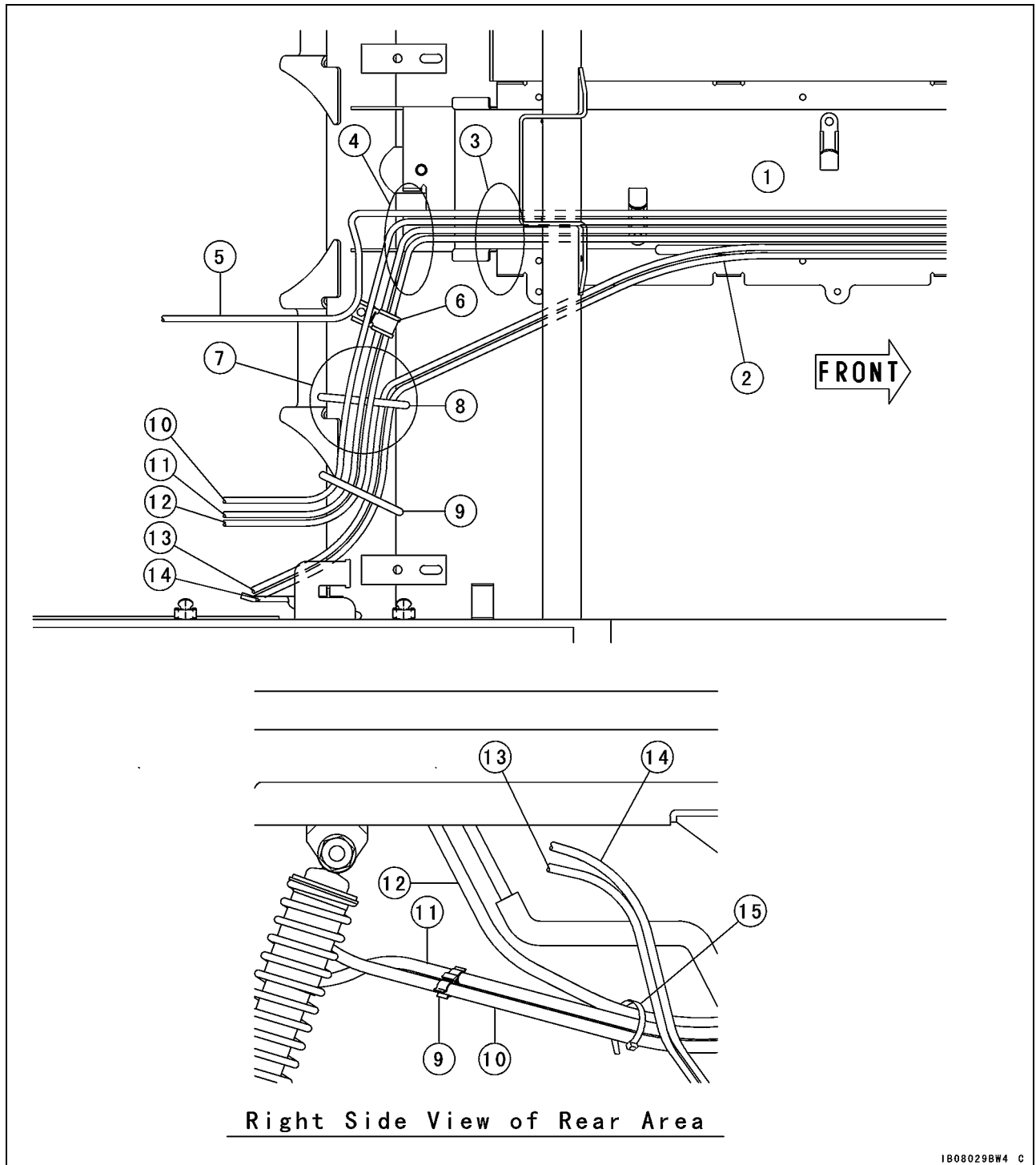

- |  |  |
|--|--|
| <ol style="list-style-type: none"> <li>1. Run the cables straight to front.</li> <li>2. Trims</li> <li>3. Run the cables under the main harness and fuel hose.</li> <li>4. Run the cables on the damper of right rear brake pipe.</li> <li>5. Choke Cable</li> <li>6. Fix the differential shift cable, 2WD/4WD shift cable and throttle cable with the clamp.</li> <li>7. Be sure that there is clearance between the cables and the shaft drive.</li> <li>8. Fix the transmission shift cable and Hi/Low shift cable with the band.</li> </ol> | <ol style="list-style-type: none"> <li>9. Clamp</li> <li>10. Differential Shift Cable: Keep 25 mm (0.98 in.) or more clearance between the rear shock absorber and differential shift cable.</li> <li>11. 2WD/4WD Shift Cable: Keep 25 mm (0.98 in.) or more clearance between the rear shock absorber and 2WD/4WD shift cable.</li> <li>12. Throttle Cable</li> <li>13. Transmission Shift Cable</li> <li>14. Hi/Low Shift Cable</li> <li>15. Band</li> </ol> |
|--|--|

## 18-16 APPENDIX

### Cable, Wire, and Hose Routing

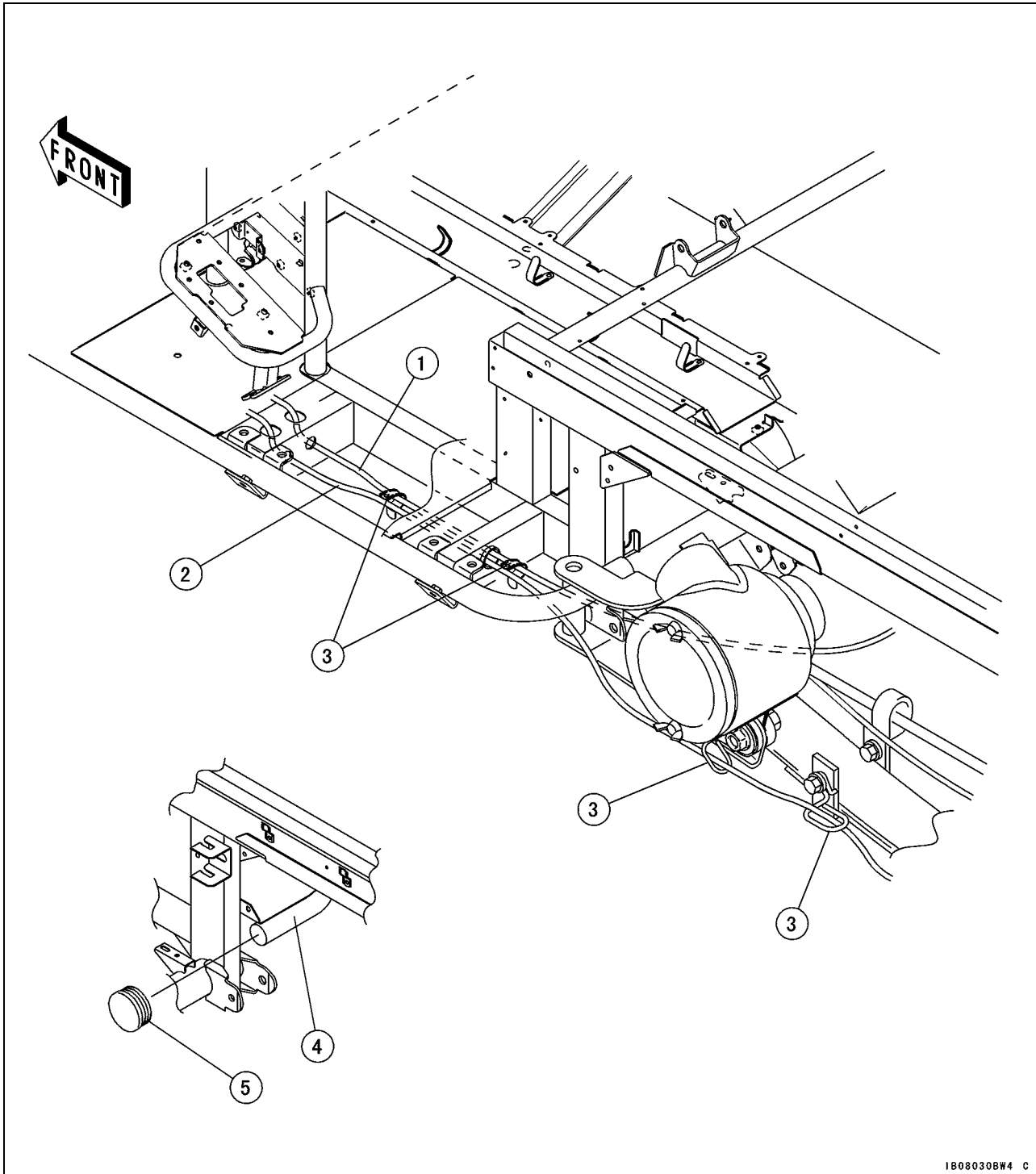

1. Right Parking Brake Cable
2. Left Parking Brake Cable
3. Clamp
4. Right Side Round Pipe End of Frame
5. Plug

## Cable, Wire, and Hose Routing

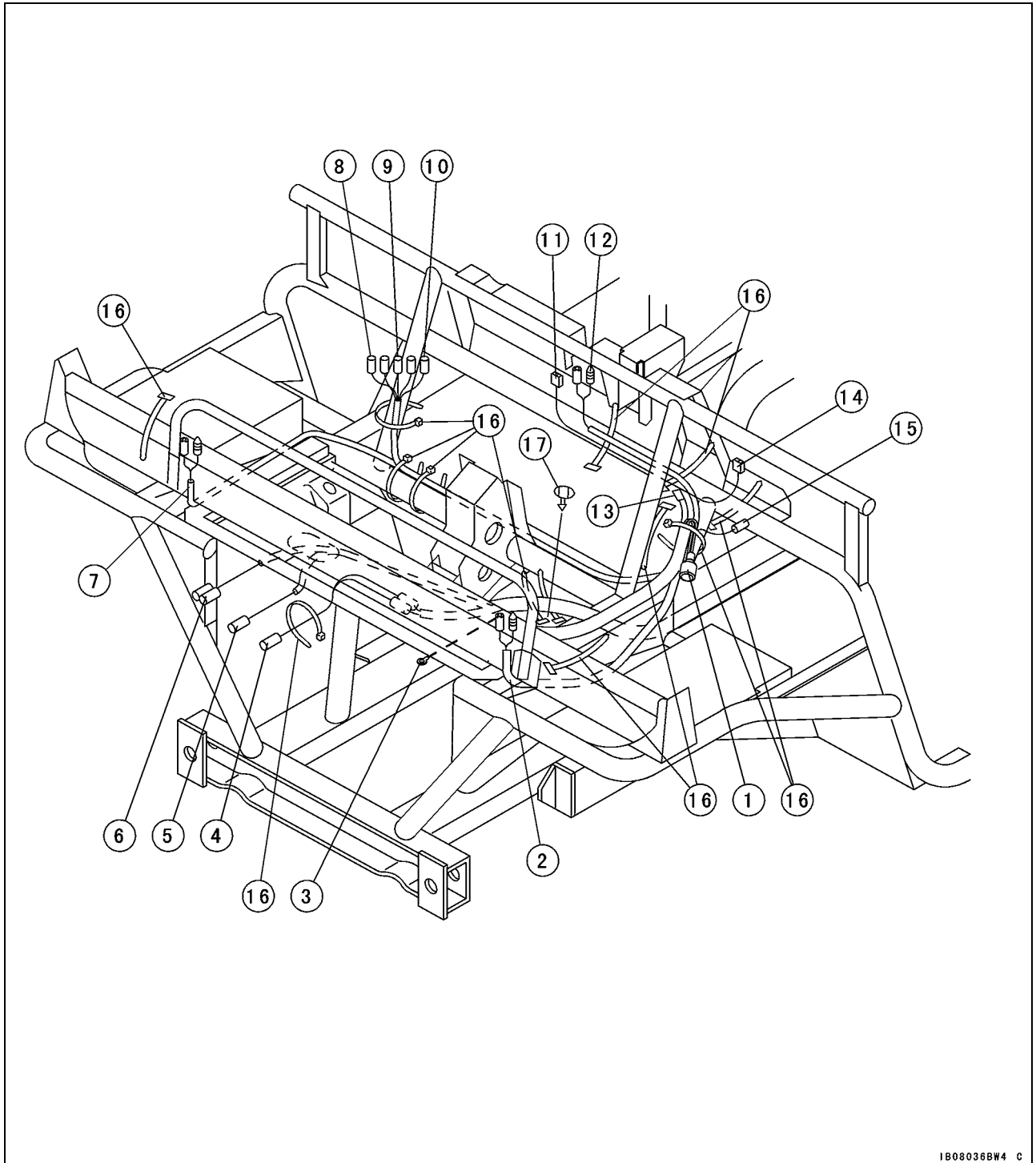

1808036BW4 C

- |   |  |
|---|--|
| 1. Accessory Connectors                                   | 10. Water Temperature Warning Indicator Light Wire |
| 2. Headlight Wire (Left)                                  | 11. Ignition Switch Wire                           |
| 3. Ground Wire (Steering Gear Assembly)                   | 12. Hour Meter Wire                                |
| 4. Radiator Fan Motor Wire                                | 13. Horn Switch Wire                               |
| 5. Radiator Fan Switch Wire                               | 14. Headlight Switch Wire                          |
| 6. Horn Wire  | 15. Speedometer Light Wire (for Option)            |
| 7. Headlight Wire (Right)                                 | 16. Band   |
| 8. Oil Pressure Warning Indicator Light Wire (for Option) | 17. Clamp  |
| 9. Power Outlet Connector Wire                            |  |

## 18-18 APPENDIX

### Cable, Wire, and Hose Routing

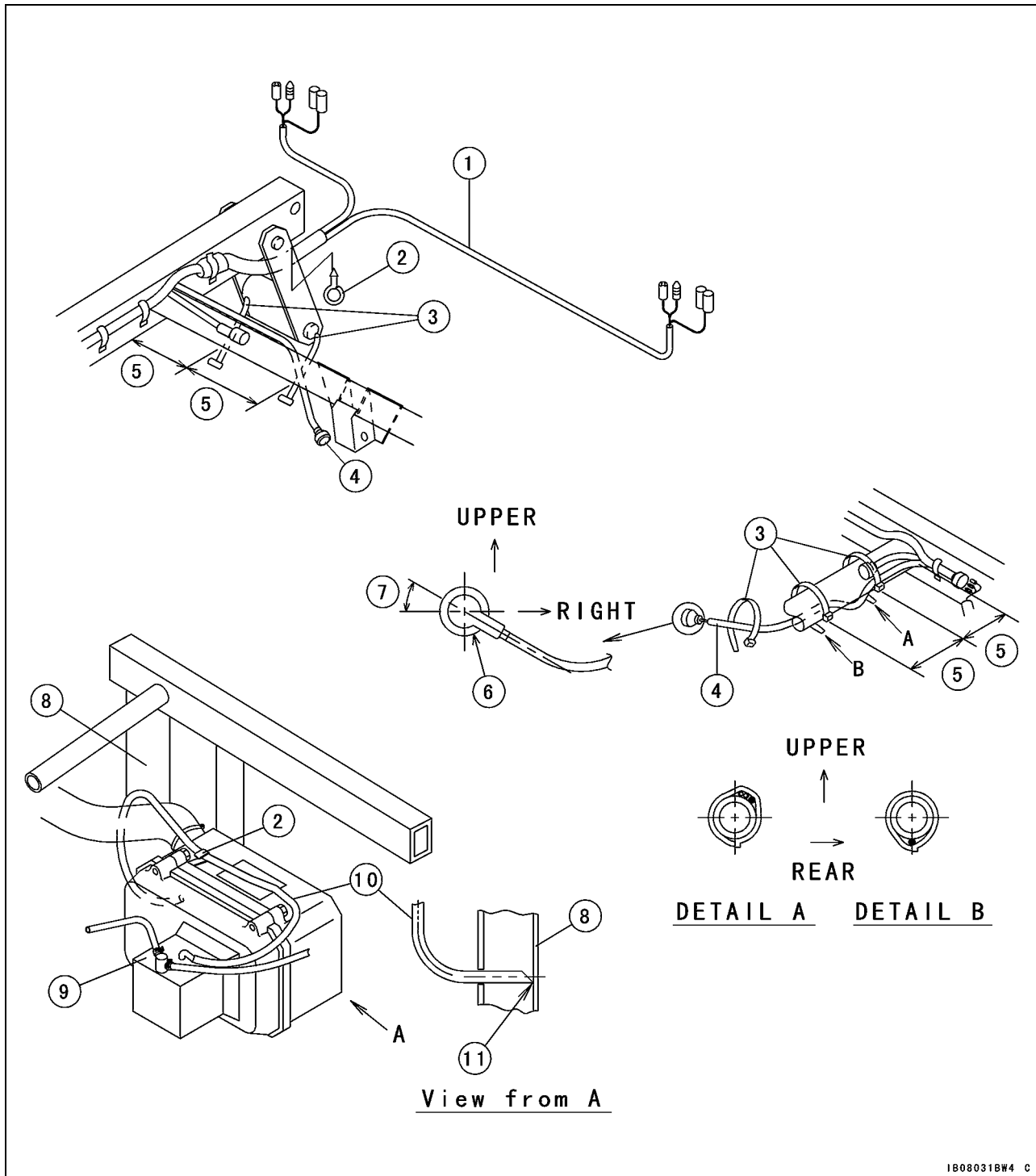

1B08031B#4 C

1. Brake/Tail Light Wire
2. Clamp
3. Band
4. Neutral Switch Wire
5. 80 mm (3.2 in.)
6. Neutral Switch Cap
7. 0 ~ 20°
8. Frame Pipe
9. Carburetor
10. Carburetor Air Vent Tube
11. Insert the air vent tube into the hole in frame pipe to inside wall of frame pipe.

Cable, Wire, and Hose Routing

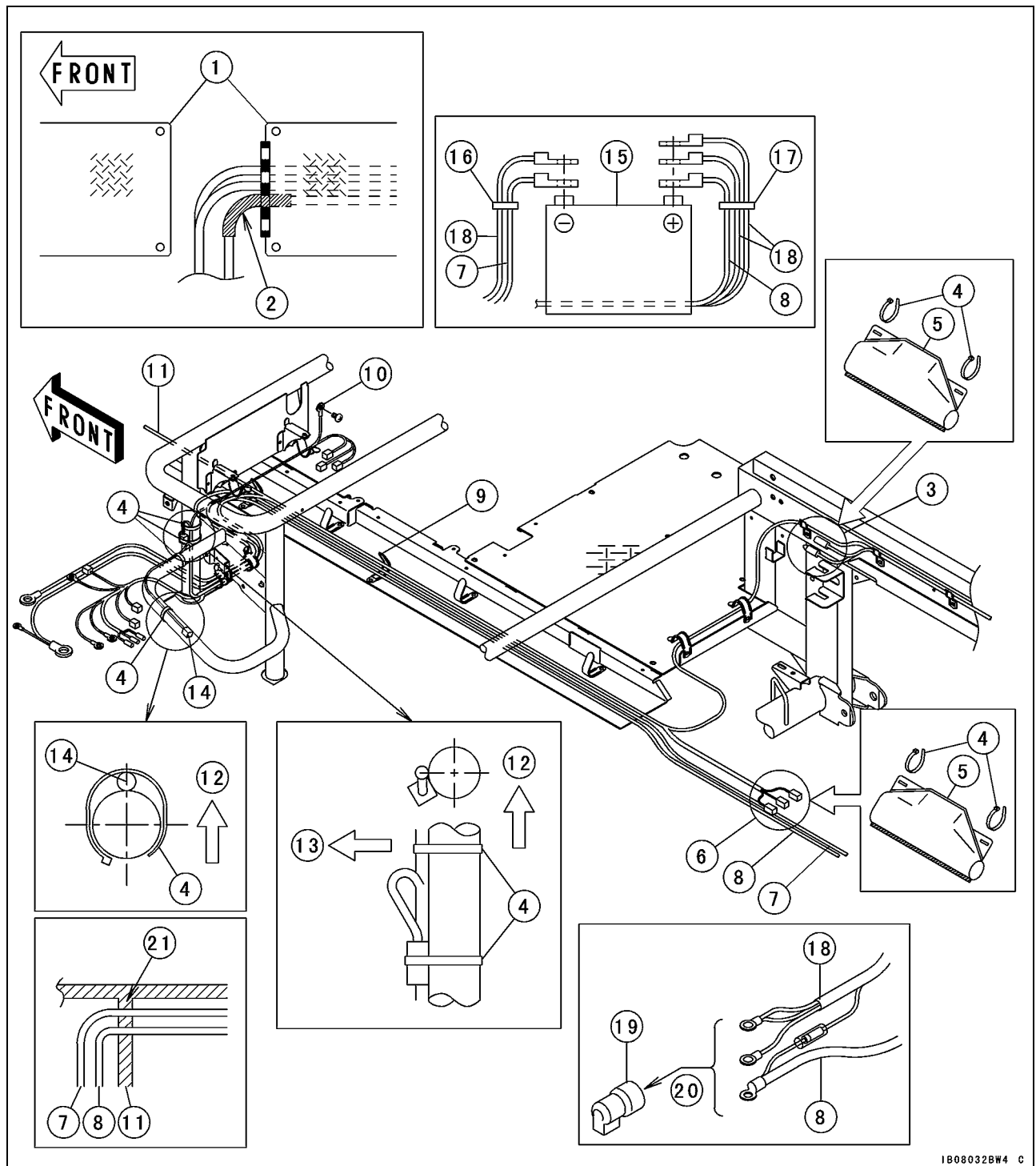

1B08032BW4 C

- |  |   |
|--|---|
| <ul style="list-style-type: none"> <li>1. Floor Center Covers</li> <li>2. Position the rubber protector for the (+) wire lead.</li> <li>3. Fuel Pump Wire</li> <li>4. Band</li> <li>5. Cover</li> <li>6. Alternator Wire</li> <li>7. (-) Wire Lead</li> <li>8. (+) Wire Lead</li> <li>9. Position the white tape on the harness.</li> <li>10. Ground Wire (Frame)</li> <li>11. Main Harness</li> </ul> | <ul style="list-style-type: none"> <li>12. Upper Side</li> <li>13. Inside</li> <li>14. Parking Brake Switch Wire</li> <li>15. Battery</li> <li>16. Black Tape</li> <li>17. Red Tape</li> <li>18. Wire Lead</li> <li>19. Cap</li> <li>20. To Battery (+) Terminal</li> <li>21. Run the battery (+) (-) wires over the main harness.</li> </ul> |
|--|---|

## 18-20 APPENDIX

### Cable, Wire, and Hose Routing

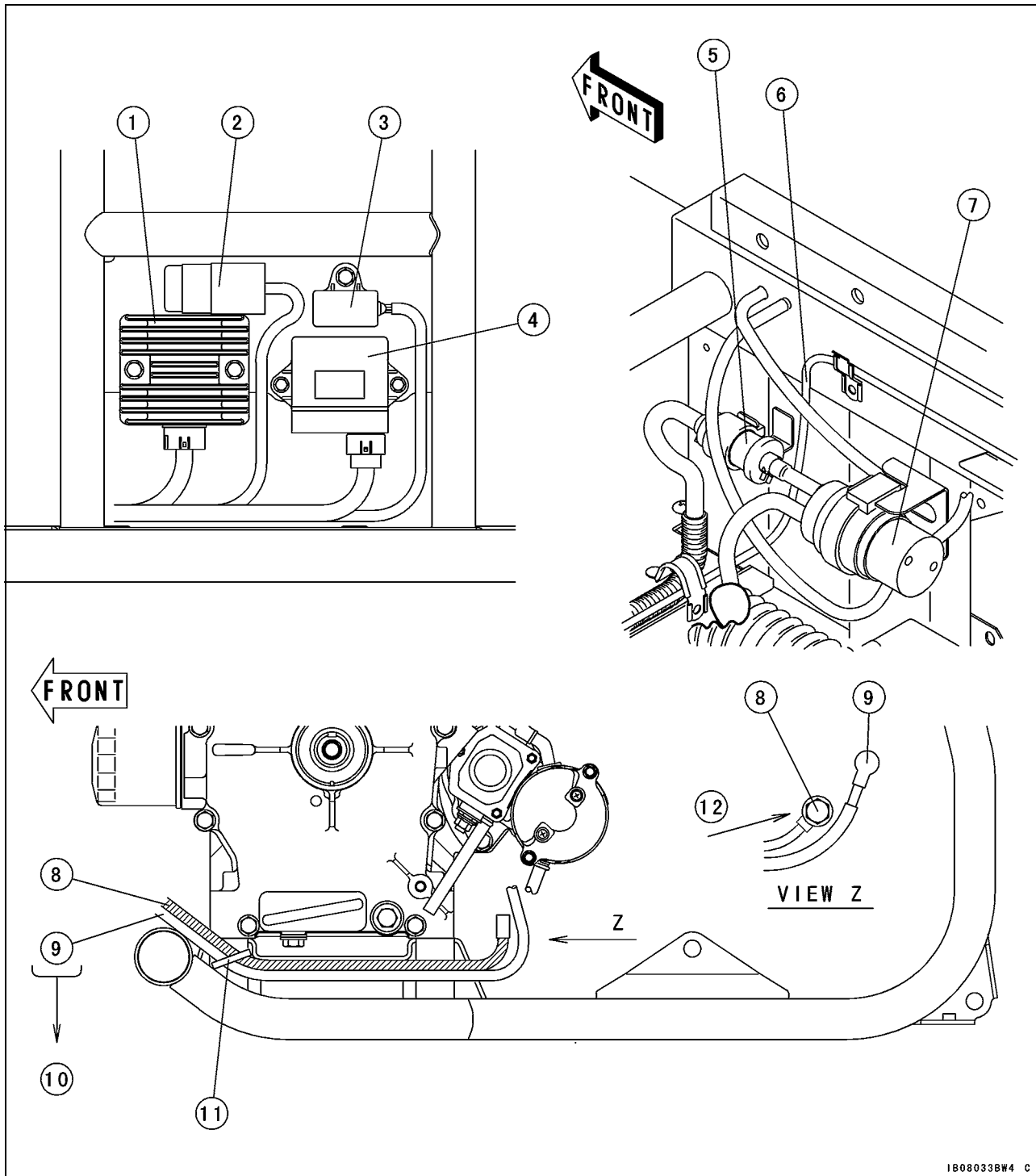

1B08033BW4 C

1. Regulator/Rectifier
2. Starter Circuit Relay
3. Fuel Pump Relay
4. Igniter
5. Fuel Filter
6. Run the harness between the frame and the fuel filter.
7. Fuel Pump
8. (-) Wire Lead
9. (+) Wire Lead
10. Run the (+) (-) wire leads on the damper of left rear brake pipe.
11. Band
12. Do not bring (+) wire lead into contact with the bolt head on the (-) wire lead.



Cable, Wire, and Hose Routing

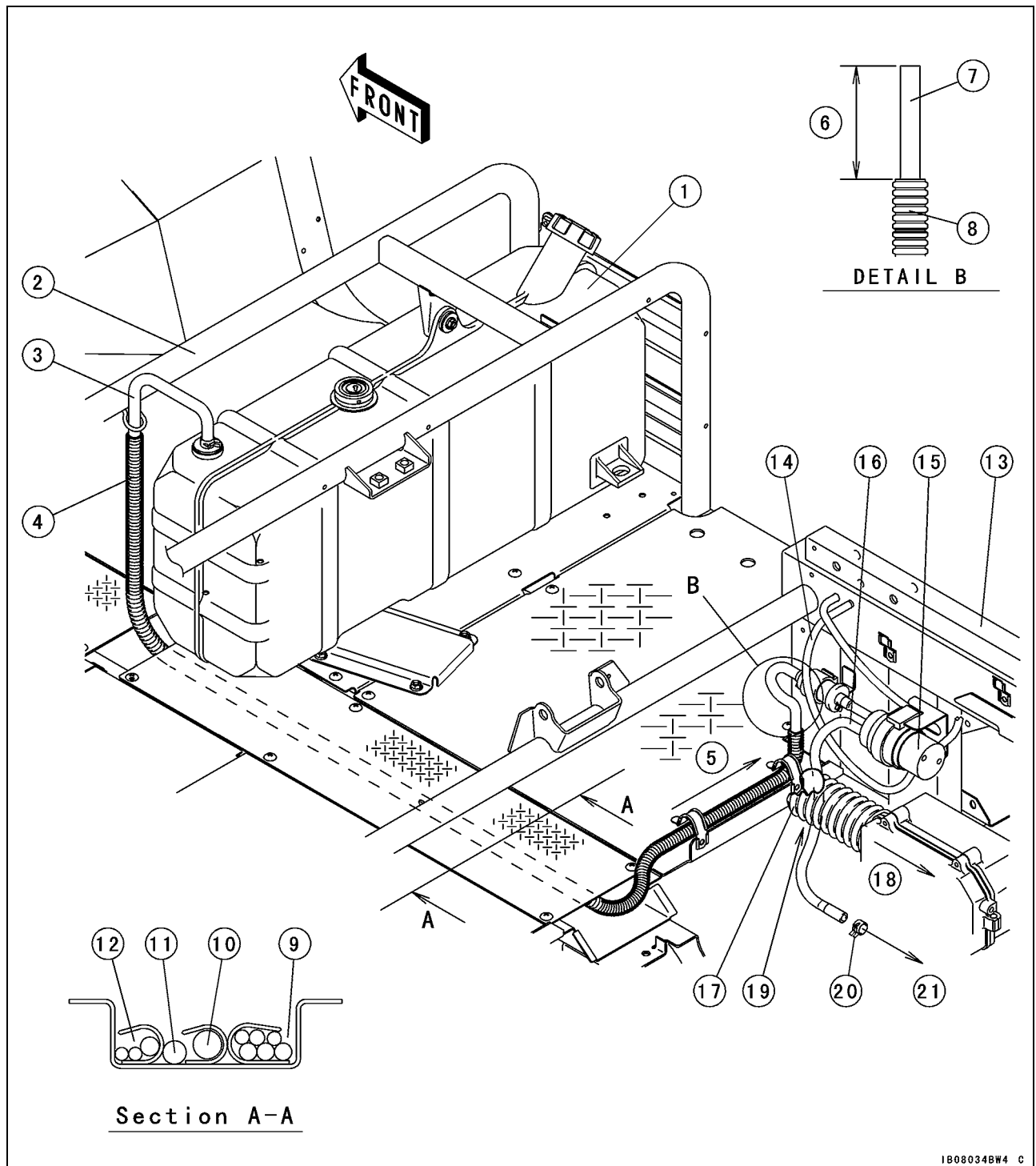

- |   |   |
|---|---|
| <ul style="list-style-type: none"> <li>1. Fuel Tank</li> <li>2. Cross Pipe</li> <li>3. Fuel Hose</li> <li>4. Protector</li> <li>5. To Fuel Filter</li> <li>6. 150 mm (5.91 in.)</li> <li>7. Fuel Hose End (Fuel Filter Side)</li> <li>8. Protector End</li> <li>9. All Cables</li> <li>10. Fuel Hose with Protector</li> <li>11. Brake Pipe</li> <li>12. Main Harness and Wire Leads</li> </ul> | <ul style="list-style-type: none"> <li>13. Frame</li> <li>14. Breather Hose</li> <li>15. Fuel Pump</li> <li>16. Install the fuel hose so that its bent portion faces inside.</li> <li>17. Air Duct</li> <li>18. To Engine</li> <li>19. Run the fuel hose under the air duct.</li> <li>20. Install the clamp so that its pinch portion faces sideward.</li> <li>21. To Inlet Pipe of Carburetor</li> </ul> |
|---|---|

1B08034BW4 C

## 18-22 APPENDIX

### Cable, Wire, and Hose Routing

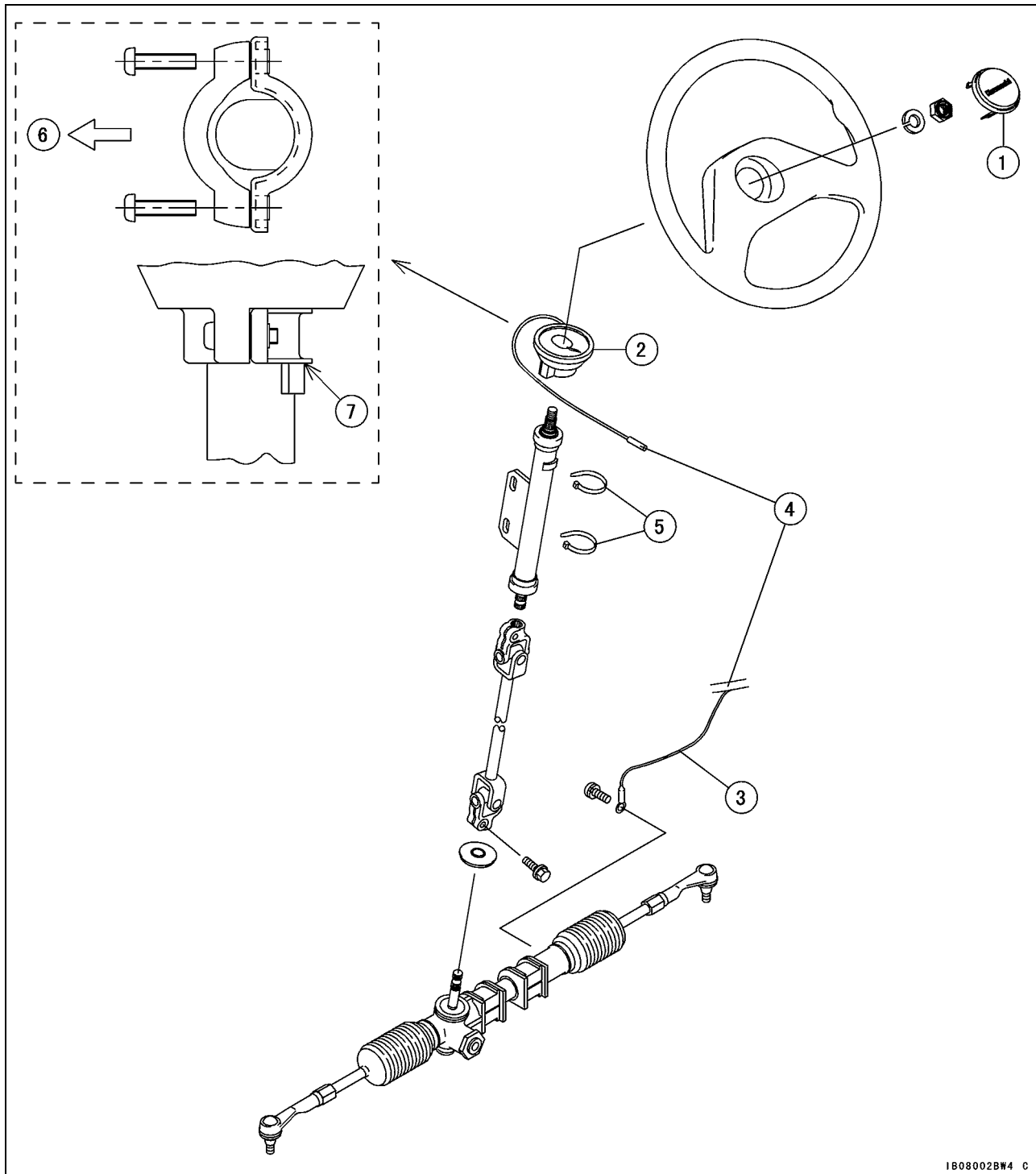

1. Horn Button
2. Horn Switch Contact
3. Ground Wire
4. to Main Harness
5. Band
6. Front
7. Installation condition of horn switch contact

## Cable, Wire, and Hose Routing

Option

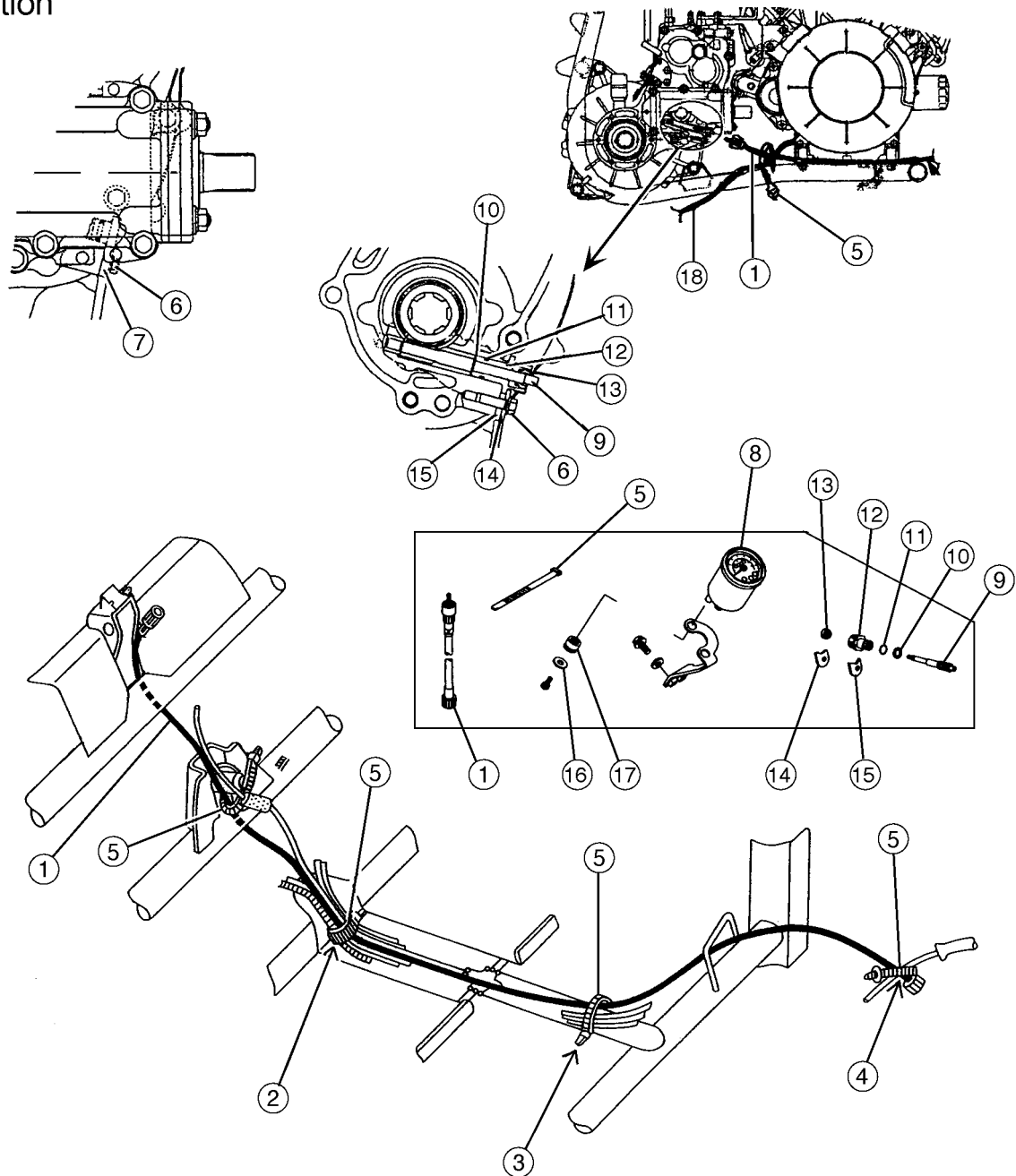

- |   |                                  |
|---|----------------------------------|
| 1. Speedometer Cable  | 9. Speedometer Gear              |
| 2. Clamp the speedometer cable with other cables, harness and brake pipe. | 10. Plain Washer 6 mm (0.24 in.) |
| 3. Clamp the speedometer cable with other cables.                         | 11. O-ring                       |
| 4. Clamp the speedometer cable with the parking brake cable.              | 12. Bushing                      |
| 5. Band   | 13. Oil Seal                     |
| 6. Bolt   | 14. Holder T = 2.3 mm (0.09 in.) |
| 7. Remove plastic cover.  | 15. Holder T = 3.2 mm (0.13 in.) |
| 8. Speedometer  | 16. Plain Washer 8 mm (0.31 in.) |
|   | 17. Damper                       |
|   | 18. Parking Brake Cable          |

## 18-24 APPENDIX

### Cable, Wire, and Hose Routing

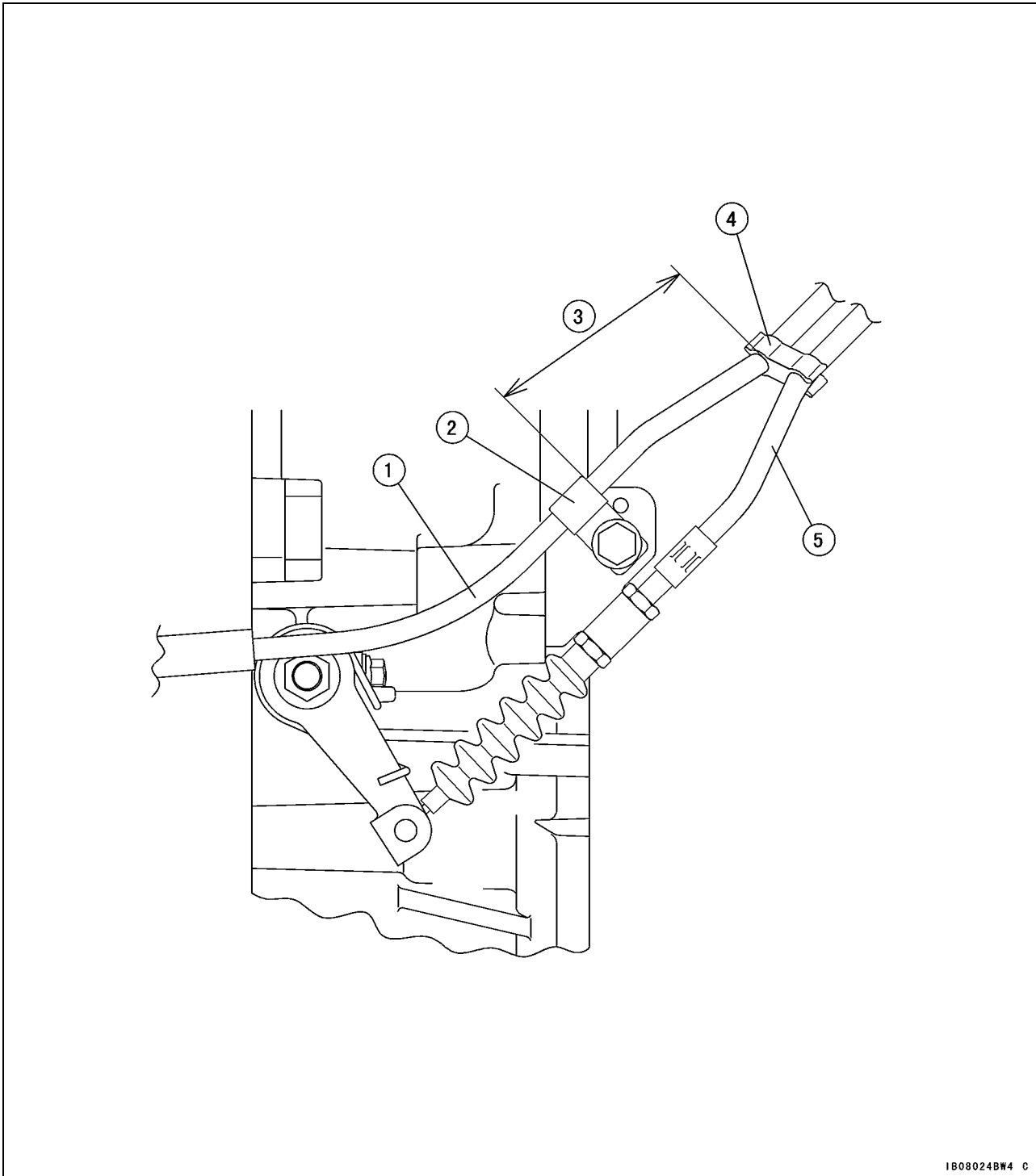

1. Differential Shift Cable
2. Cable Bracket
3. 100 mm (3.9 in.)
4. Cable Clamp
5. 2WD/4WD Shift Cable

### MODEL APPLICATION

Year	Model	Beginning Frame No.
2005	KAF620-J1	JK1AFCJ1□5B500001
2005	KAF620-K1	JK1AFCK1□5B500001

□:This digit in the frame number changes from one machine to another.



KAWASAKI HEAVY INDUSTRIES, LTD.  
Consumer Products & Machinery Company

Part No.99924-1350-01

Printed in Japan