



VALVE MANUFACTURERS ASSOCIATION API 622 – API 624

Written by Rich Davis

Manager Business Development Western Hemisphere &
China

Flexitallic L.P., Deer Park, Texas

Presented By: Steve Butler, Shell Global Solutions

FUGITIVE EMISSIONS SOURCES

Valves are considered to account for approximately 60% of Fugitive Emissions of a Refinery

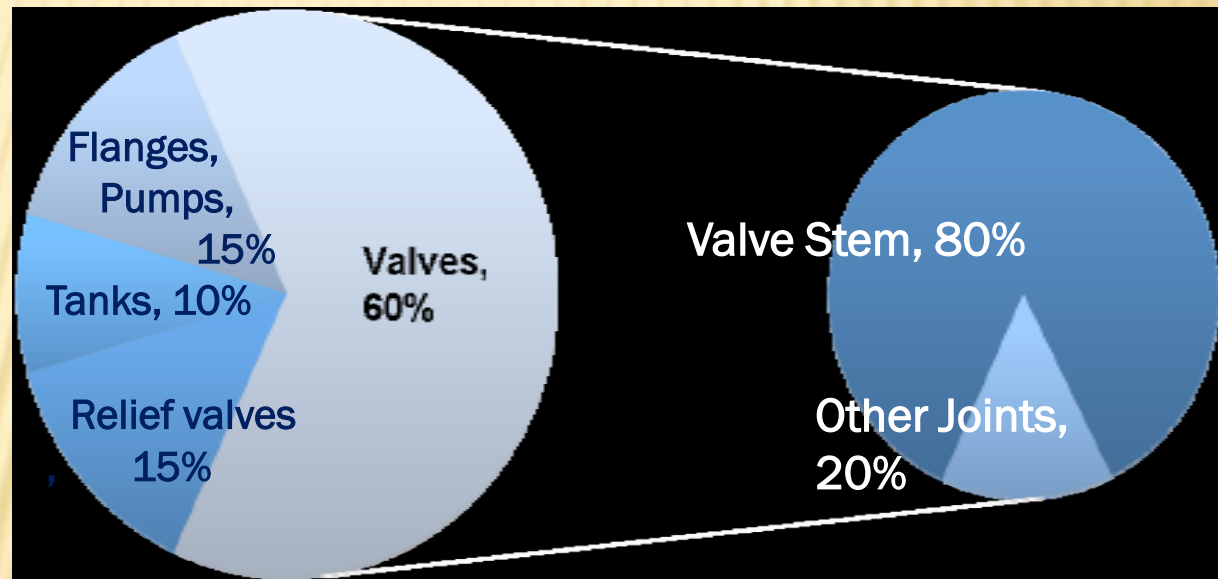

*Source - Monitoring and Containment of Fugitive Emissions from Valve Stems, University of British Columbia, Vancouver

HISTORY – PERF 93-20

- Testing started with the Petroleum Environmental Research Forum – 93-20
- 10 identical valves, with statistical evaluation to determine which conditions cause emissions.

Figure A7-1
Valve Test Stand

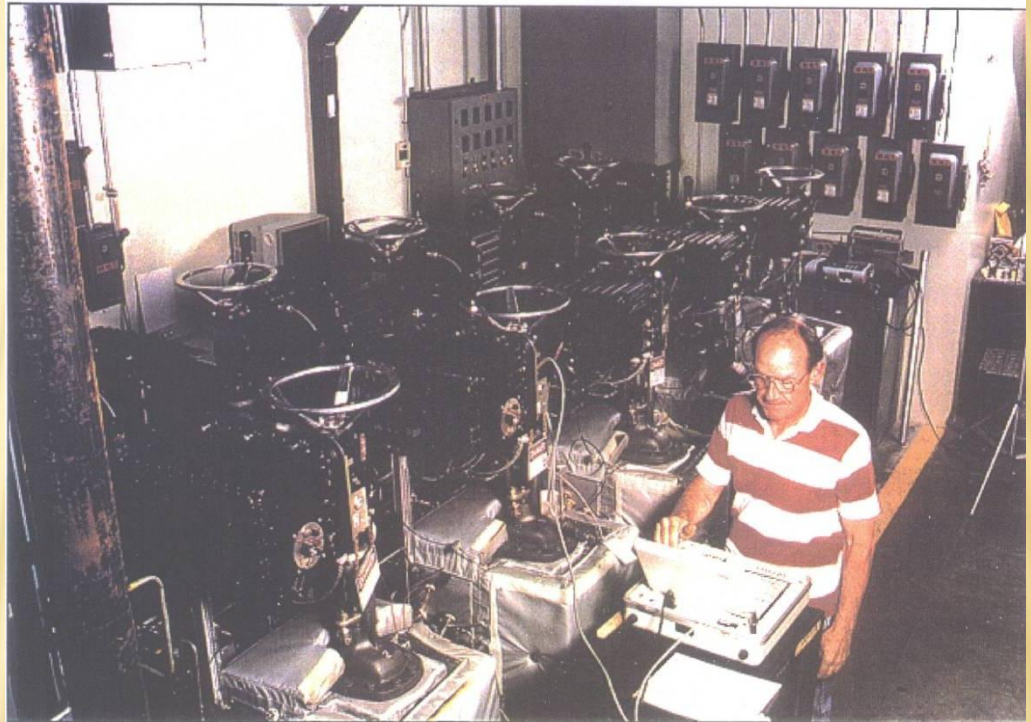

– Confidential –
For PERF 93-20 Participants Only

API-622

API 622 Type Testing of Process Valve Packing for Fugitive Emissions

API STANDARD 622

SECOND EDITION, AUGUST 2011

API-622 KEY CHANGE

1.4 (Removed) Packing tested to this standard may or may not perform the same when used in a manufacturer's valve. Performance to a specified emission limit may be confirmed by re-testing the packing in an actual valve in accordance with Section 4.4 of this Standard.

One of the single most important factors concerning the revision to the testing method was the removal of paragraph 1.4. With this removal, the test is no longer considered as an alternative to ISO 15848-1.

API-622

- ✘ Test fixture packing gland dimensions and tolerances are listed in the standard.
- ✘ The test fixture is arranged to follow the PERF testing. It relays the information obtained in that testing.
- ❖ Mechanical cycles = 1510
- ❖ The test fixture shall be equipped with an actuator capable of stroking the test stem to simulate the mechanical cycle of a valve as follows:
 - ❖ Rotating stem:
 - ❖ Rate: 10° to 15° per second
 - ❖ Rotation: $90^{\circ} \pm 5^{\circ}$

TEST FIXTURE

Key Information about the packing gland and tolerances required for manufacture are contained within the standard.

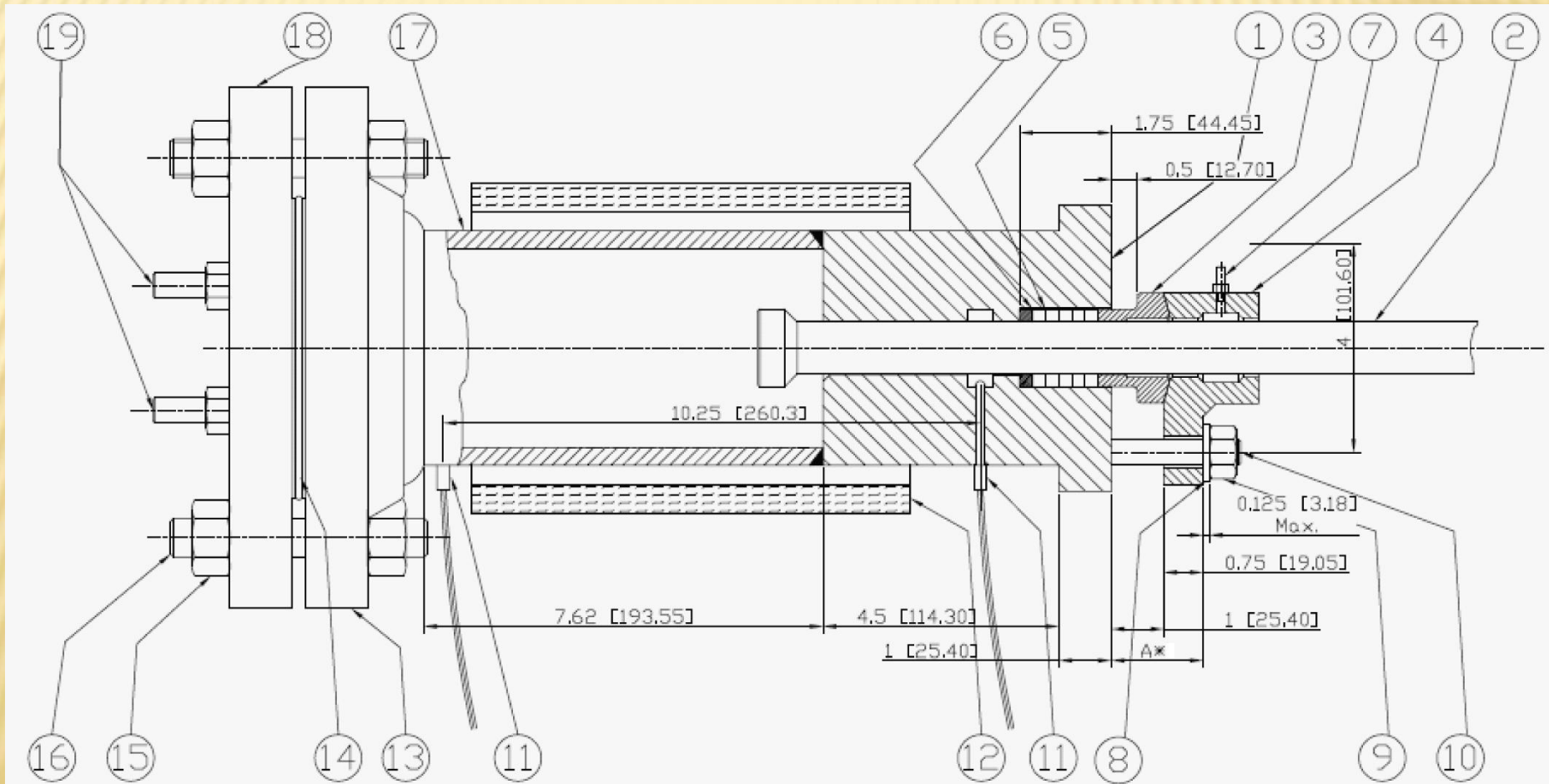

TEST PROCEDURE

Test Fluid: The test fluid used is dry methane gas, 97% minimum purity, subjected to a temperature range from ambient to 260°C (500°F) and pressures from 0 to 4,137 kPag (0 TO 600 PSIG).

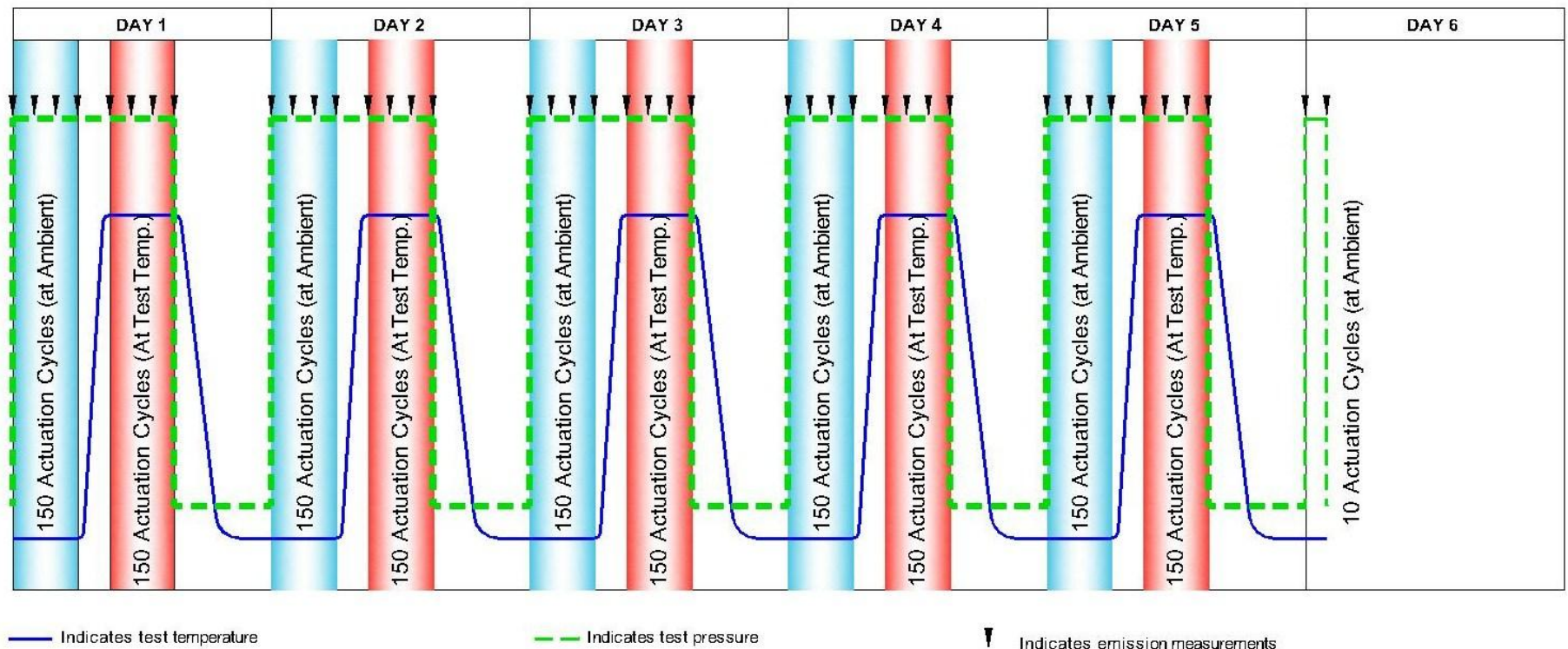

API-622 LEAK MEASUREMENT

- ✘ Leak measurements conducted initially at the start of each day and at the completion of every 50 cycles. A minimum of ten (10) readings shall be taken over a one (1) minute duration. The average reading shall be calculated and recorded.
- ✘ Any reading more than fifty percent (50%) greater than the average, the readings shall be repeated.
- ✘ Leak measurement is conducted using a fixed detection probe located at the 12 o'clock position directly above the potential leak point.
- ✘ Leak measurements are taken both in the static and dynamic condition.
- ✘ Dynamic condition measurements are taken on the opening and closing cycles and the average of both are recorded.

The leak detector measures the combined flows from the stem OD and from the gland OD

API-622 EMISSIONS COLLECTION

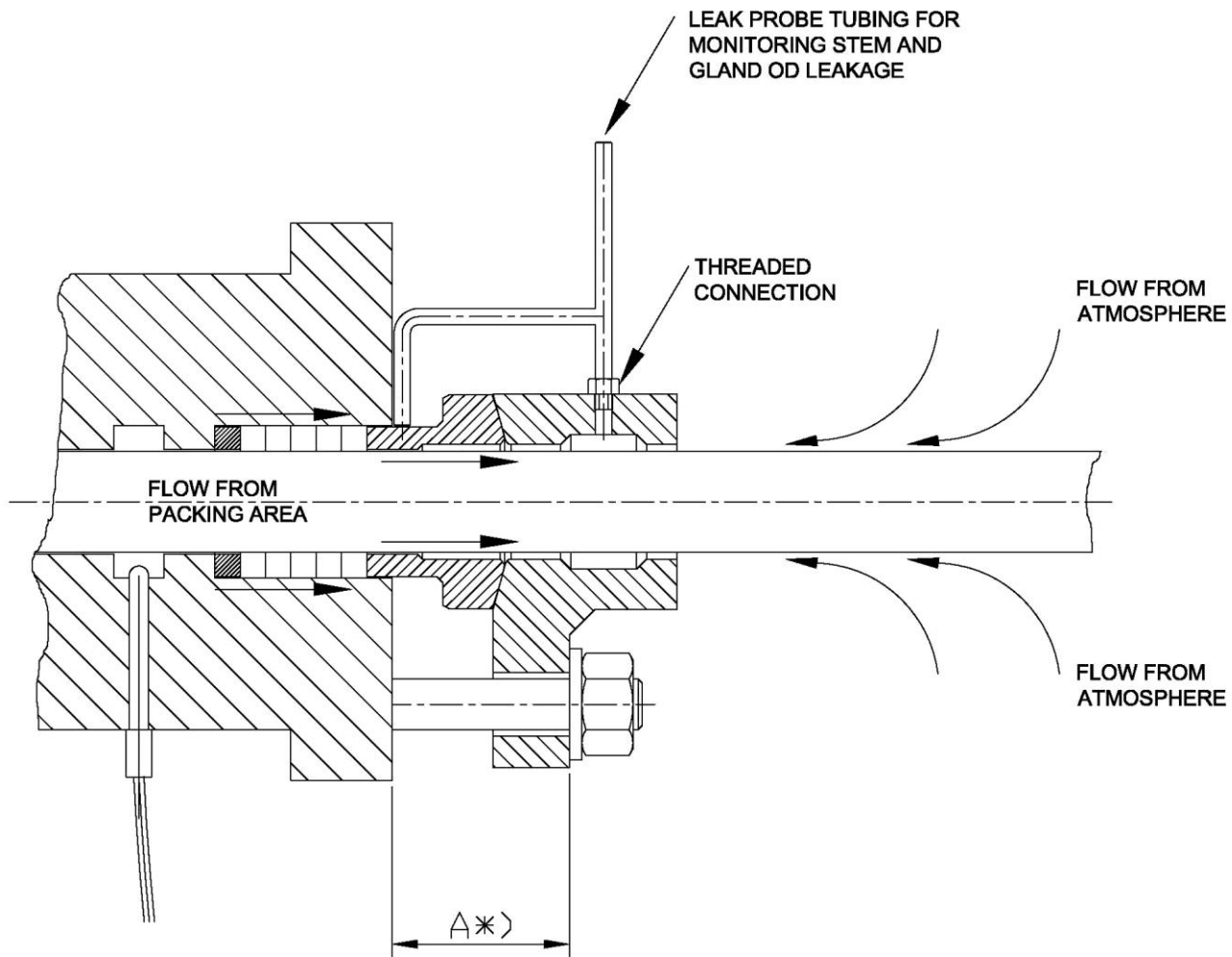

API-622 WEIGHT LOSS TESTING

Graphite Foil Weight Loss Test Procedure

- ✘ Evaluate the ability of Graphite to resist oxidation.
- ✘ Testing using FSA test procedure FSA-G-604-07 for oxidation of Graphite.
- ✘ **Weight loss greater than 15% is not acceptable.**
- ✘ This upper limit is a New Addition to the standard.

API-622 PACKING CONSTRUCTION

Braided Packing Ring

- ✘ Conducted in an oven with full exposure to air (oxygen-rich environment).
- ✘ Select three test rings of a sample packing set. If the packing set is comprised of more than one type of packing ring, each type is tested.
- ✘ Discontinue test if weight loss exceeds 50%.

Lubricant Content

- ✘ PTFE content established by determining the % total fluorine in the packing, and comparing with a base fluorine percentage of 76, as follows:
 - + Determine total percent of fluorine content.
 - + Divide total percent of fluorine by 0.76 to obtain the approximate percent of PTFE content.

API-624

- ✘ **Type Testing of Rising Stem Valves
Equipped with Flexible Graphite Packing
for Fugitive Emissions**
- ✘ **REVISED DRAFT – STILL IN REVIEW**

API-624

- ✘ The standard specifies the requirements and acceptance criteria (100 ppmv) for fugitive emission type testing of rising and rising-rotating stem valves equipped with packing previously tested in accordance with API Standard 622.
- ✘ Packing shall be suitable for use at service temperatures -29°C to 538°C (-20°F to 1000°F).
- ✘ The type testing requirements are based upon elements of EPA Method 21.
- ✘ Valves larger than NPS 24 and valves greater than class 1500 are outside the scope of this standard.

API-624 VALVE SELECTION & PRE-TEST

- The test valve shall be completely assembled and ready for testing. The test valve shall be randomly selected from manufacturer or distributor stock where such stock is available. For valves not in stock, the manufacturer shall certify that the test valve was not modified in any way to meet type test requirements and is a typical representation of the manufacturer's stock product. Valve selection shall be approved by the purchaser.

API-624 VALVE SELECTION & PRE-TEST

- Body-bonnet and gland bolting torque shall be verified to be in accordance with published manufacturer's installation specifications. Prior to type testing, it is permissible to operate the test valve (at ambient temperature and under pressure) to ensure that the packing is properly installed and consolidated in the stuffing box.

API 624 TYPE TESTING

- ✘ The stem orientation for a test valve shall be vertical
- ✘ As a safety precaution, the air in the valve cavity shall be purged with an inert gas prior to starting the testing.
- The test medium used shall be methane gas, 97% minimum purity.

API-624 TYPE TESTING

- + Valves are subjected to a total of 310 mechanical cycles and 3 thermal cycles. Mechanical cycling begins with the valve at ambient temperature.
- + An optional low temperature test at -29°C (-20°F) may be performed if requested by the purchaser.
- + The elevated test temperature shall be $260^{\circ}\text{C} \pm 2$ percent ($500^{\circ}\text{F} \pm 5$ percent).
- + The test pressure shall be the lower of 600 psig or the maximum allowable pressure at 500°F per ASME B16.34 for the applicable material group and shall be held constant throughout the test.

API 624 ACTUATION

- The test valve may be equipped with a method of actuation capable of stroking the stem to simulate the mechanical cycle of a valve at the rate of 1 mm to 5 mm (0.04 in. to 0.20 in.) per second. The method of actuation should not impose additional side loads on the stem or packing. Running torque values shall be recorded on the first and last cycle of testing.

API 624

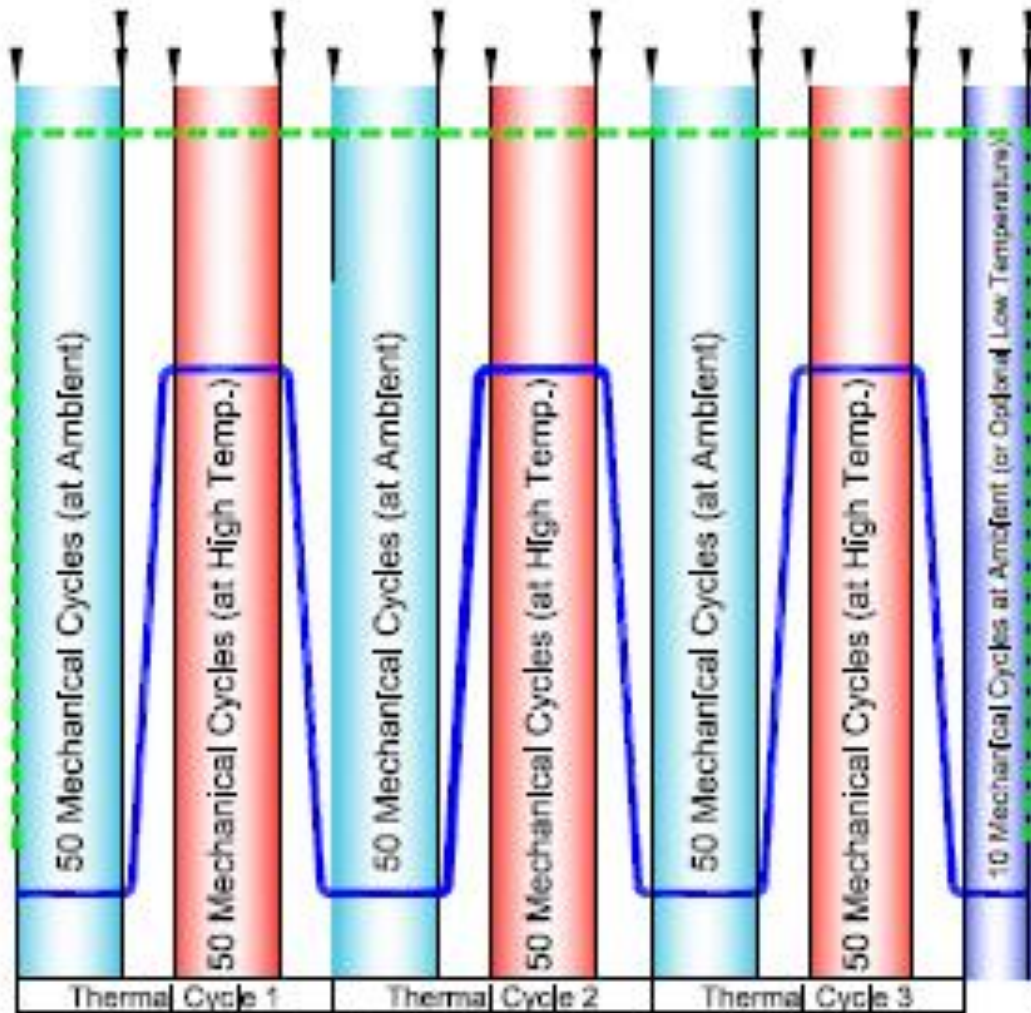

— Indicates test temperature

- - - Indicates test pressure

↑ Indicates static emission measurements

↑↑ Indicates both static and dynamic emission measurements

API 624 LEAK MEASUREMENT

- ❖ Packing leakage measurements around the full circumference of the stem OD and packing OD and the highest reading is recorded. Static and dynamic stem leakage measurements are to be taken.
- ❖ Leak measurements are sniffed using a detection probe.
- ❖ No packing adjustment during type testing is permitted.

API624 ACCEPTANCE CRITERIA

- ✘ The Fugitive Emissions Test Report in Appendix A shall indicate “pass” when the measured leakage throughout the test does not exceed **100 ppmv**.

API 624 VALVES QUALIFIED

- + All valves of the same basic design as the test valve may be deemed to have been type tested, subject to the following additional limitations:
- + For API 602 valves, a NPS $\frac{3}{4}$ class 800 test valve may be used to qualify all valves NPS 1 and smaller valves up to and including class 800. For API 602 valves, a NPS 1-1/2 class 800 test valve may be used to qualify all valves NPS 1-1/4 through NPS 2-1/2 up to and including class 800

API 624 VALVES QUALIFIED

- ✘ For API 602 valves, a NPS $\frac{3}{4}$ class 1500 test valve may be used to qualify all valves NPS 1 and smaller in class 1500. For API 602 valves, a NPS 1-1/2 class 1500 test valve may be used to qualify all valves NPS 1-1/4 through NPS 2-1/2 in class 1500.
- ✘ For all other valves, a test valve may be used to qualify valves from two nominal sizes smaller to one nominal size larger and one pressure class lower than the test valve.

API 624 VALVES QUALIFIED

- ✘ Any change in valve stem sealing system design including, but not limited to, packing material, packing manufacturer, or packing type/model requires a re-qualification.
- ✘ If the location of the valve manufacturing facilities is different than what is listed on the API 624 certificate, the purchaser may request re-qualification.

API 624

✘ Post-test Inspection

- + Valve shall be disassembled and components; including stem, packing, stem nut, gland follower, and stuffing box; shall be inspected and condition documented.
- + Sealing components shall be photographed in accordance with section 9.4.

✘ Recording and Documentation

- + As a minimum, test results shall be provided on the Fugitive Emissions Test Report provided in Appendix A.
- + Valves qualified by this standard shall be clearly and permanently marked as “API 624”.

THANK YOU

Questions?