

# Steam Driven Vapour Absorption Chiller

120 TR to 2500 TR (420 kW to 8775 kW)

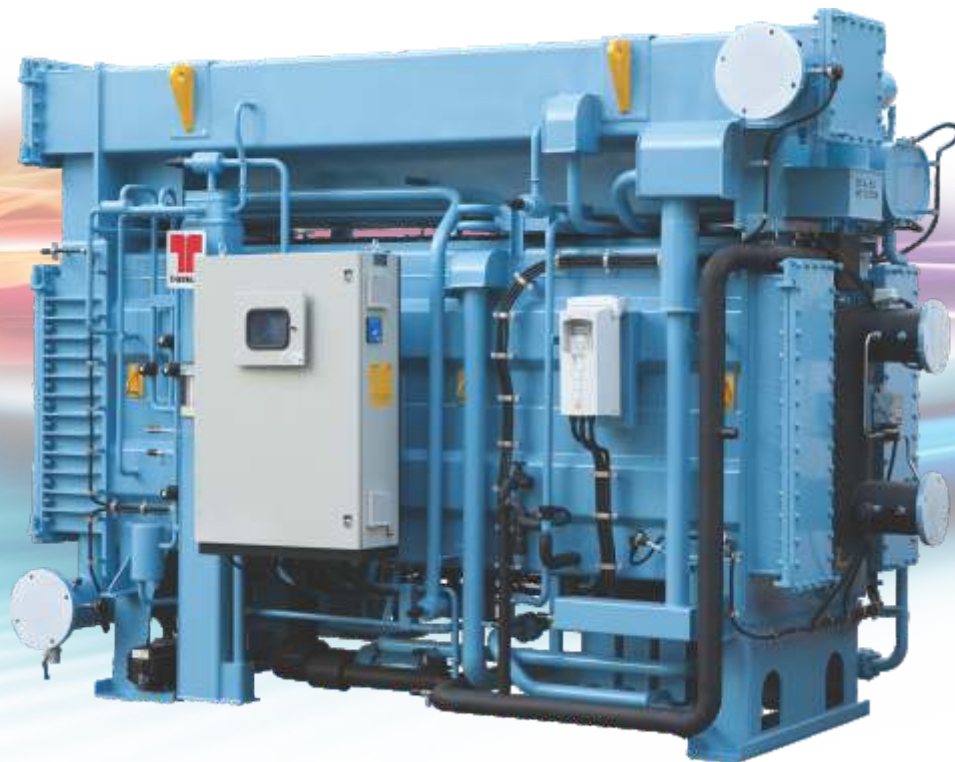



## ■ Cooling & Heating Division - Cooling SBU

The Cooling SBU of THERMAX promotes Vapor Absorption Chillers as a cost effective and environment friendly alternative to electricity driven compression chillers.

It offers expert solutions in Process Chilling & Air Conditioning for industrial as well as commercial applications. Cooling SBU's strength lies in customized solutions as per the requirements of its customers.

Unlike electrical chillers, Absorption Chillers are powered by heat. These machines can run on a variety of heat sources, e.g. steam, hot water, liquid/gaseous fuels, exhaust gases and/or a combination of above.

## ■ Thermax - Conserving Energy, Preserving the Environment

Vapor Absorption Technology from Thermax is at work for clients in more than 50 industries including Pharmaceuticals, Chemicals, Fertilizers, Steel, Textiles, Petrochemicals, Food & Beverages and Automobile industries as well as in Hotels, Commercial Complexes, Shopping Complexes, Office Buildings, Educational Institutes, Airports, Cinema halls and Medical Centers.

Manufacturing capabilities of Thermax's Cooling SBU are confirmed by the fact that, over the years, Thermax has installed thousands of machines in more than 70 countries including USA, Brazil, Germany, Spain, UK, Italy, UAE, Saudi Arabia, India, China, Australia, Thailand, Philippines, Malaysia, Russia and Nigeria with the products conforming to the respective country standards like ETL, CE, TUV, DNV, ASME etc. Thermax has its fully owned subsidiaries namely Thermax Inc. in USA, Thermax Europe Limited in UK and Thermax (Zhejiang) Cooling and Heating Engg. Company Limited in China.

Thermax believes in efficient and responsive services to its clients and exhibits in its way of business, by giving optimal and quality solutions and achieving customer delight. Thermax has a worldwide sales, service and distribution network to fulfill the needs of its valuable customers.

## ■ Vision

To be a globally respected high performance organization offering sustainable solutions in energy and environment.

## ■ Sustainable Solutions

From Cooling to Heating, from Power Generation to Air Purification, from Water and Sewage Treatment to Speciality Chemicals, THERMAX Solutions are improving life at work in many ways.

Every year THERMAX helps generate 6,000 MW of Power, produce 100,000 tons of steam, provide 4 billion tons of Cooling and treat 1,000 million litres/day of Water and Waste.

THERMAX today is a major Engineering and Environment company with revenues of USD 800 million and with market capitalization of over USD 1 billion.

THERMAX was one of 20 Indian companies in Forbes list of "Asia's Best Under a Billion Companies" in 2005 and 2006 and was ranked "No. 1 among the top 21 wealth creators" in India over the last 5 years by a leading investment journal.

THERMAX brings to customers enriched experience of industrial applications, and expertise through technological partnerships and strategic alliances.

Operating from its Headquarters in Pune (Western India), Thermax has built an international sales & service network spread over South East Asia, Middle East, Africa, Russia, UK, US and China. It has full fledged ISO 9001:2000 and ISO 14000 accredited manufacturing setups.





## ■ Manufacturing & Testing World-Class Facilities

### Quality assured manufacturing to international codes

Thermax manufactures environment friendly and energy efficient vapor absorption chillers at its plants in Pune, India, and China. Its state-of-the-art manufacturing facility has been awarded with ISO 9001 and ISO 14001 certifications.

Stringent quality control procedures, along with a skilled workforce, ensure that a highly reliable product leaves the factory. The equipment and manufacturing processes conform to international standards.

Thermax's pressure part manufacturing has been approved by ASME and bears the 'S', 'U', 'H' and 'R' stamps. The vapor absorption chillers are CE certified for the European Union and ETL listed for the US and Canadian markets. They conform to the Kyoto Protocol and are in absolute tandem with the Clean Development Mechanism code (CDM).

Thermax also conforms to Environmental Management System standard 14001 and OHSAS 18001.



CNC twin spindle drilling machine with high speed and direct feed technology ensures fine tube hole finish and accuracy, which is important for leak tight expansion and effective heat transfer.

A Helium leak detection test ensures there is no leak at welding joints.



Welding robot for high precision automatic welding.



CNC gas cutting machine for plate cutting ensures precision cutting of shell plates and profile cut tube plates.



Press Brake Machine



Rolling Machine



# ■ Salient Features for Matchless Reliability, Efficiency and Durability

## Advanced Series Flow Cycle

Advanced Series Flow Cycle to avoid simultaneous occurrence of high temperature and high concentration, thereby minimizing the probability of corrosion.

Parameter	Parallel Flow	Advanced Series Flow
HTG Temperature	162°C	155°C
LiBr Concentration	64 - 65%	60.5%
LTG Temperature	88°C	90°C
LiBr Concentration	62 - 64%	63%

## Unique Two Stage Evaporation Technology

Thermax chillers are designed based on unique two stage evaporation technology. This ensures that the specific heat input is one of the lowest in the industry, resulting in higher cooling output for the same heat input. Also, larger temperature difference in chilled water to the tune of 30°C, is possible.

## Split Absorber Design

Split absorber design helps to improve absorption rate of LiBr, thereby improving efficiency. This also reduces surface area under cold insulation.

## Gravity Feed LiBr and Refrigerant Distribution Mechanism

Nozzle-less, non-clogging gravity feed distribution mechanism for stable and reliable operation throughout the life of the machine. Drop in performance due to nozzle wear, clogging eliminated. Need for separate pump for spray eliminated, resulting in lower power consumption.

## Zero Crystallization

Unique State-of-the-Art concentration monitoring and control that virtually eliminates crystallization and is distinctly different from the conventional auto de-crystallization. This helps the chiller to operate even at low cooling water inlet temperature without crystallisation.

## Lowest Chilled Water/ Brine Outlet Temperature

Thermax innovative absorption chillers can deliver leaving chilled water temperatures down to 3.5°C and leaving chilled brine solution up to 0°C, enabling absorption chillers to be used for applications involving low chilled water / brine temperature.

## Best-in-class Coefficient of Performance

Process design to ensure maximum internal Heat recovery to give the lowest specific steam consumption benefit to the customer.

### Avenues for COP improvement

Enlargement of heat transfer area	Done by all manufacturers
Two stage evaporation	Unique feature of Thermax chillers
Advanced series flow	Design unique to Thermax chillers
Refrigerant heat exchanger	Unique feature of Thermax chillers

## Highly Efficient and Reliable Solution Heat Exchangers for Maximum Internal Heat Recovery

All regenerative heat exchangers are high efficiency plate type heat exchangers with SS316 plates for improved reliability

## Welded Plate Heat Exchanger for Condensate Heat Recovery

Specially designed welded type plate heat exchanger with SS316 plate used as heat reclaimer for condensate heat recovery. These are best suited for two phase flow and are highly reliable compared to conventional brazed heat exchangers.

## Isolation Valves for Canned Motor Pumps

Double seal isolation valves and bolted pumps facilitate easy maintenance of the machine mounted canned motor pumps without any loss of vacuum in the system. This significantly reduces the down time of the chiller.

## Ferritic Stainless Steel Tubes in Generators

Titanium stabilized ferritic stainless steel tubes (SS430 Ti) used in both high temperature and low temperature generator for lowest differential thermal expansion, thereby protecting the tubes from stress corrosion cracking. Suitable for steam with dissolved ammonia compounds, where copper alloys are not recommended.

## De-oxidised Low Phosphorus Copper Tubes

Copper tubes conforming to ASTM/JIS standards, with phosphorus content maintained below 0.005 ppm, used in chilled water and cooling water circuits. This protects the tubes from hydrogen embrittlement in LiBr environment.



## Improved Online Purge System

Factory fitted high efficiency purge system with purge cooler, continuously removes non-condensable gases from the chiller into the storage tank while in operation.

## PLC Based Control Panel

Thermax chillers are provided with State-of-the-Art PLC based control panel, user friendly 7 inch touch screen operator interface and data logging system.

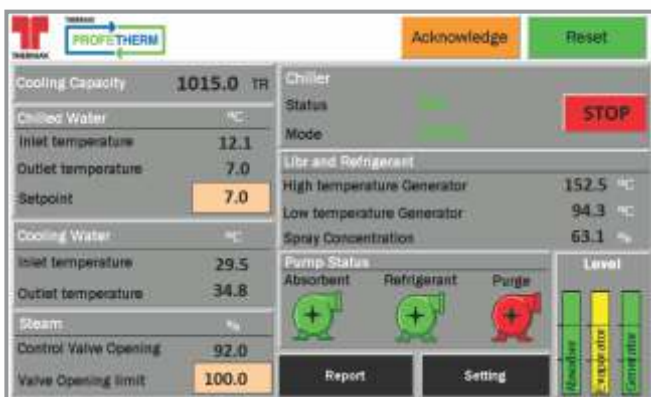

## Non-clogging Filters to protect Solution Heat Exchangers

Stainless steel filters provided on both high temperature and low temperature generator outlet to safe guard the solution heat exchangers. Non-clogging design ensures uninterrupted circulation of lithium bromide, resulting in smooth operation.

## Non-toxic Corrosion Inhibitor

New generation non-precipitating, non-toxic molybdenum based corrosion inhibitor which is more effective than conventional inhibitors based on Chromate (Cancer causing, prohibited in several countries) and Nitrate.

## Variable Frequency Drive on Absorbent Pump

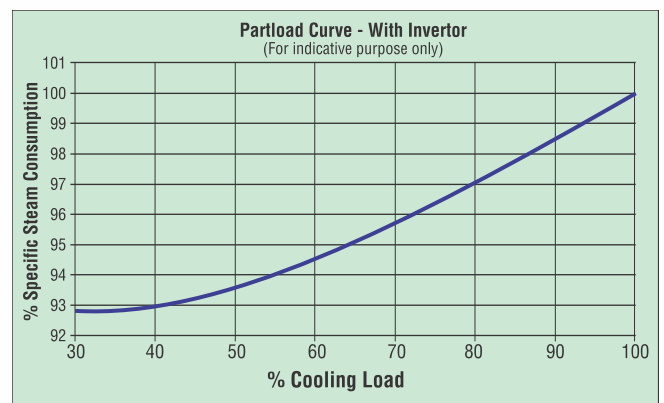

Variable Frequency Drive on absorbent pump for higher reliability, savings in steam & savings in power, during part load operation.

## 10-100% Stepless Modulation

For cooling loads ranging from 10% to 100% of the designed capacity, the steam control valve automatically varies steam flow in order to maintain the temperature of chilled water leaving the chiller.

## Multi-stage Level Control

Multiple stage level control in three locations enables effective operation during part load and prevents cavitation of refrigerant and absorbent pumps.

## BAS/DCS Connectivity

Direct connectivity of machine PLC panel with Third party monitoring systems like BAS (Building Automation System), DCS (Distributed Control System) or PLC (Programmable Logic Controller) can be provided via Modbus RTU protocol on RS485 network.

## ■ Customized Offering

### Tailor Made, High Efficiency Solutions for Low Steam Pressure

Double effect lithium bromide absorption chillers can be offered for steam pressures as low as 45 Psig, where conventionally single effect chillers are used.

### LiBr Absorption Chillers for Sub-Zero Cooling Applications

Double effect Lithium bromide absorption chillers can be offered for leaving brine temperatures as low as 23°F, offering great savings in operating costs.

### Stand-by Pumps

For critical applications where scheduled maintenance of pumps cannot be carried out, stand-by absorbent, refrigerant and/or vacuum pump can be provided.

### Fully Automatic Purging

The automatic purging system eliminates the need for periodic monitoring of purge tank pressure and operation of purge system.

### Special Tube Metallurgy

Special tube materials like Cupro-Nickel, Stainless Steel or Titanium depending on water quality on site. This not only improves the reliability & efficiency but also makes the chiller suitable for special applications involving sea water and brackish water.

## THERMMONITOR - Remote Performance Monitoring System (RPMS)

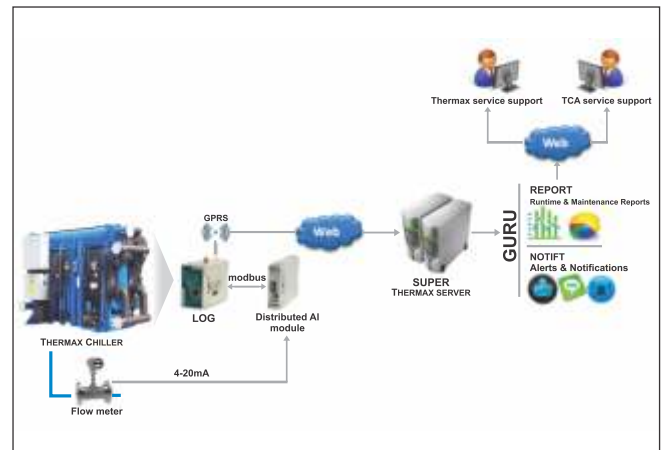

Advanced feature that monitors the chiller performance & provides data via internet. This feature enables the facility manager or Thermax engineer to monitor the performance remotely. It offers features like e-log book, status, trends, abnormal maintenance schedules, alerts etc.

### Multi Sectional Shipment Arrangement

For convenience of shipping, the absorption chillers can be shipped in two or more sections depending upon the site requirement. This is particularly convenient arrangement for retrofit / replacement jobs.

## ■ Instrumentation and Safety Features

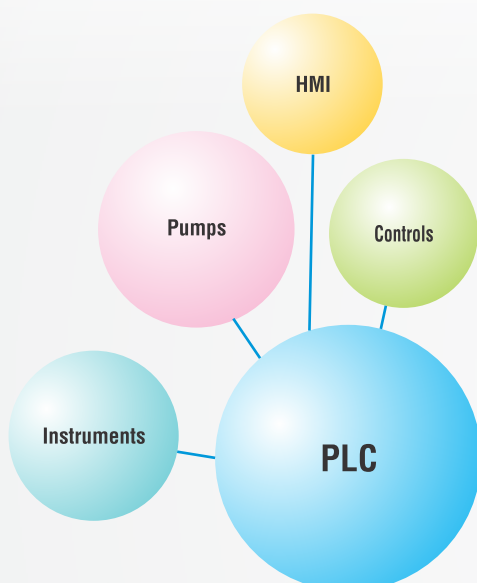

## ■ Holistic Customer Care

Cooling Unit of C&H division has a wide network of Service Centers throughout the globe to ensure quick response to customers. With a cumulative service experience of over 4000 VACs operating for more than 25 years, Thermax service personnel are equipped to deliver the right solution to the users. Thermax has developed specific modules for different types of users depending on their usage pattern, conforming to our proactive approach.

For the benefit of its customers Thermax offers various value added services like:

- Preventive maintenance contract
- Operations & manning
- Localized customer training programs



## ■ Testing Procedure

As the Vapor absorption chillers work under vacuum conditions, the manufacturing of these chillers is very critical with respect to leak tightness. Hence it is necessary to follow stringent quality control procedures and also perform leak detection test. Understanding the importance, Thermax carries out the leak detection test in the following sequence:

### ▶ Helium Shroud Test

In this test, the chiller is fully covered by a polythene sheet and helium is passed from below, to observe the cumulative leak rate of the entire chiller. It can detect leakage to the tune of  $5.0 \times 10^{-7}$  std cc/ sec.

### ▶ Helium Spray Test

Helium, the next smallest molecule after Hydrogen, can leak through very minute holes. In this test helium is sprayed on all the joints of the chiller. As the chiller is under vacuum conditions, leakages, if any, will result in helium entering into the chiller and thus will be displayed on the screen of helium leak detector. Every machine has to clear this test before it is shipped to the customer.



## ■ Performance Testing Facility

Thermax has a state-of-the-art test bay capable of testing various types of vapour absorption chillers - steam driven, hot water driven, fuel fired, exhaust driven and a combination of these up to a capacity of 3500 TR (12300 kW). The entire testing facility is centrally operated by sophisticated Distributed Control Systems (ABB make) and can be operated by the touch of a button.

- ▶ Steam : 50 - 3500 TR (175 kW to 12300 kW)
- ▶ Exhaust : 50 - 3500 TR (175 kW to 12300 kW)
- ▶ Hot Water : 10 - 1730 TR (35 kW to 6080 kW)
- ▶ Fuel Fired : 50 - 3000 TR (175 kW to 10540 kW)

This is one of the largest testing facility for absorption chillers available in the world.

# Specification Sheet

MODEL NUMBER		UNITS	2B 2K C	2B 2L C	2B 2M C	2B 2N C	2B 3K C	2B 3L C	2B 3M C	2B 4K C	2B 4L C	2B 4M C	2B 5K C	2B 5L C	2B 5M C	2B 5N C	2B 6K C	2B 6L C	2B 7K C	2B 7L C	2B 7M C	2B 8K C	2B 8L C	2B 8M C	2B 8N C	2B 9K C	2B 9L C		
Chilled Water Circuit	Cooling Capacity	TR	120	143	182	217	270	304	361	401	454	503	553	613	717	802	903	1010	1180	1307	1439	1664	1800	2009	2160	2350	2500		
	Flow rate	m <sup>3</sup> /hr	72.4	86.3	109.8	130.9	162.9	183.4	217.8	241.9	273.9	303.4	333.6	369.8	432.5	483.8	544.7	609.2	711.8	788.4	868.0	1003.7	1085.8	1211.9	1302.9	1417.6	1508.0		
	Pressure loss	m LC	1.2	1.4	3.7	4.4	4.2	4.5	7.4	6.4	6.5	6.9	6.7	6.8	5.2	5.3	9.8	10.0	4.3	4.6	4.9	4.8	5.0	7.8	8	12.0	12.1		
Cooling Water Circuit	Flow rate	m <sup>3</sup> /hr	120	143	182	217	270	304	361	401	454	503	553	613	717	802	903	1010	1180	1307	1439	1664	1800	2009	2160	2350	2500		
	Pressure loss	m LC	2.3	2.5	6.4	6.7	6.2	6.4	5.1	4.2	4.4	4.7	4.1	4.3	5.5	5.7	7.7	8	7.2	7.8	8.4	7.3	7.8	9.9	10.6	11.1	11.5		
	Connection Diameter	mmNB	150			200			250			300			350			400			450			500					
Steam Circuit	Steam Consumption	Kg/hr	456	543	692	825	1026	1155	1372	1524	1725	1911	2101	2329	2725	3048	3432	3839	4484	4967	5468	6324	6840	7634	8208	8930	9500		
	Connection Diameter (Steam)	mmNB	65			80			100			100			125			150			200								
	Connection Diameter (Drain)	mmNB	40			40			40			50			50			65			65			80					
Overall Dimensions	Length	mm	2850		3870		3990		4590		4720		4810		5870		7340		7480		7520		8870		10800				
	Width	mm	2050		1890		1960		2010		2150		2370		2470		2460		2950		3190		3310		3600				
	Height	mm	2680		2680		2790		2790		3060		3250		3350		3400		3760		4150		4180		4400				
Weight	Maximum Shipping	x 1000 kg	6.0	6.1	7.2	7.5	8.9	9.1	10.2	12.1	12.5	12.8	14.9	15.3	18.7	19.2	24.1	24.7	34.5	35.3	36.2	42.0	42.9	49.1	50.2	67.2	71.5		
	Operating	x 1000 kg	6.6	6.8	8.0	8.3	10.0	10.3	11.5	13.8	14.4	14.7	17.3	17.8	21.6	22.3	27.7	28.6	40.5	41.6	42.9	50.0	51.2	58.1	59.5	78.4	84.0		
Clearance	Tube Cleaning/ Removal	mm	2500		3500		3600		4200		4250		4350		5400		6860		6900		6900		8220		9600				
Electric Supply	Absorbent Pump Motor Rating	kW (A)	2.2 (6)			3.0 (8)			3.7 (11)			5.5 (14)			6.6 (17)			7.5 (20)			9.0 (27)			11.0 (28)		15.0 (35)			
	Refrigerant Pump Motor Rating	kW (A)	0.3 (1.4)												1.5 (5)												2.2 (8.5)		
	Vacuum Pump Motor Rating	kW (A)	0.75 (1.8)																										
	Total Electric Input	kVA	7.6			9.1			11.2			13.4			15.5			20.3			25.3			26.0		33.6			
	Power Supply		415 V (±10%), 50 Hz (±5%), 3 Phase + N																										

- Notes:** 1) Model Nos. : 2B XX C Steam Fired Double Effect Vapour Absorption Chillers    2) Chilled water inlet / outlet temperature = 12 / 7°F  
 3) Cooling water inlet / outlet temperature = 32 / 37.2°F    4) Steam at Control Valve inlet is at 8 kg/cm<sup>2</sup>(g) pressure in dry saturated condition.    5) Minimum cooling water inlet temperature is 10°F  
 6) Ambient condition shall be between 5 to 45°F    7) Maximum allowable pressure in chilled / cooling water system = 8 kg/cm<sup>2</sup>(g)    8) Maximum allowable pressure in steam system = 10.5 kg/cm<sup>2</sup> (g)  
 9) Control panel electric input = 1 kVA    10) All water nozzle connections to suit ASME B16.5 Class 150    11) Technical specification is based on JIS B 8622  
 12) Please contact Thermax representative / office for customized specifications

## Operating Principle

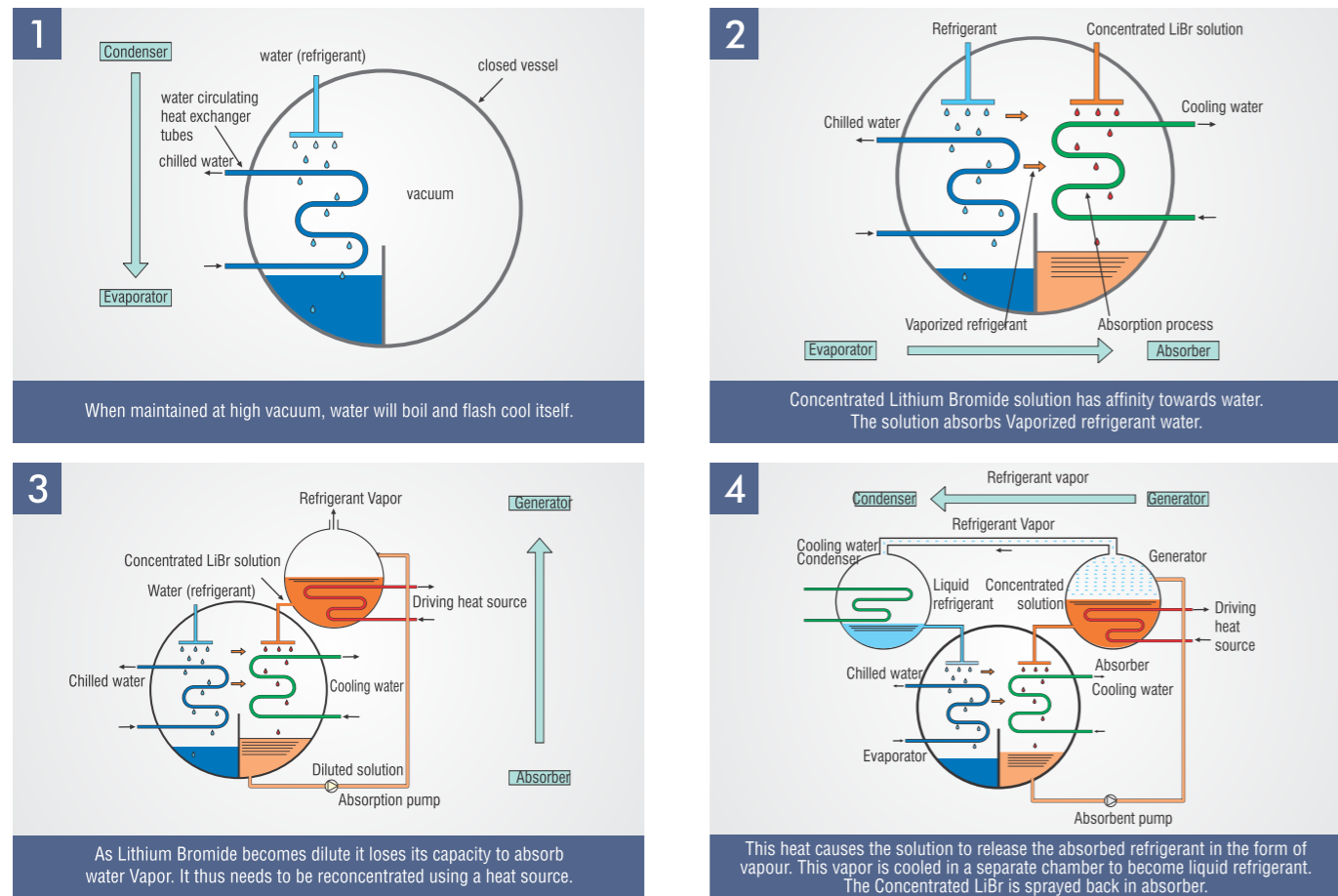

## Cycle Diagram

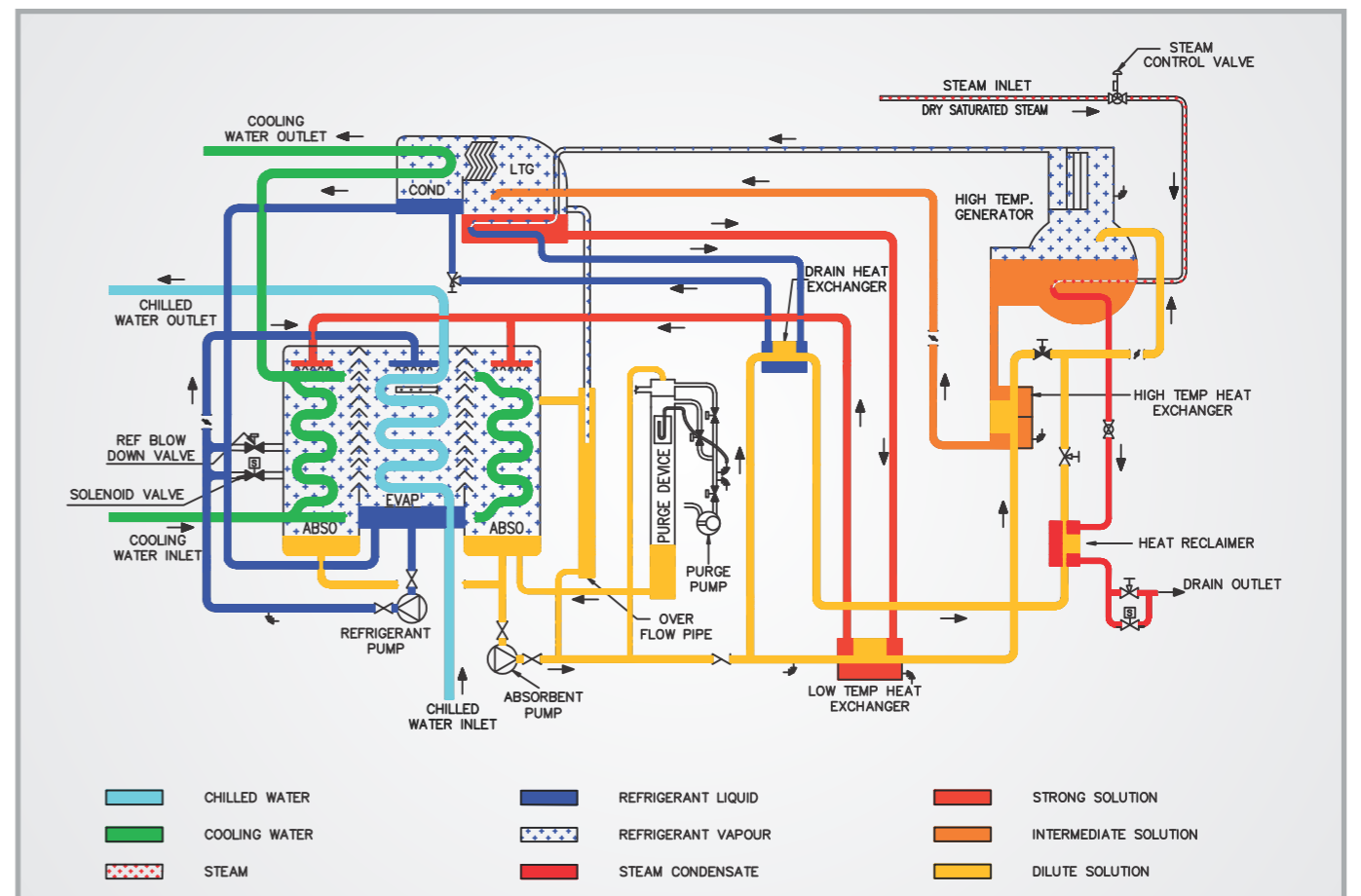



# Foundation Drawing

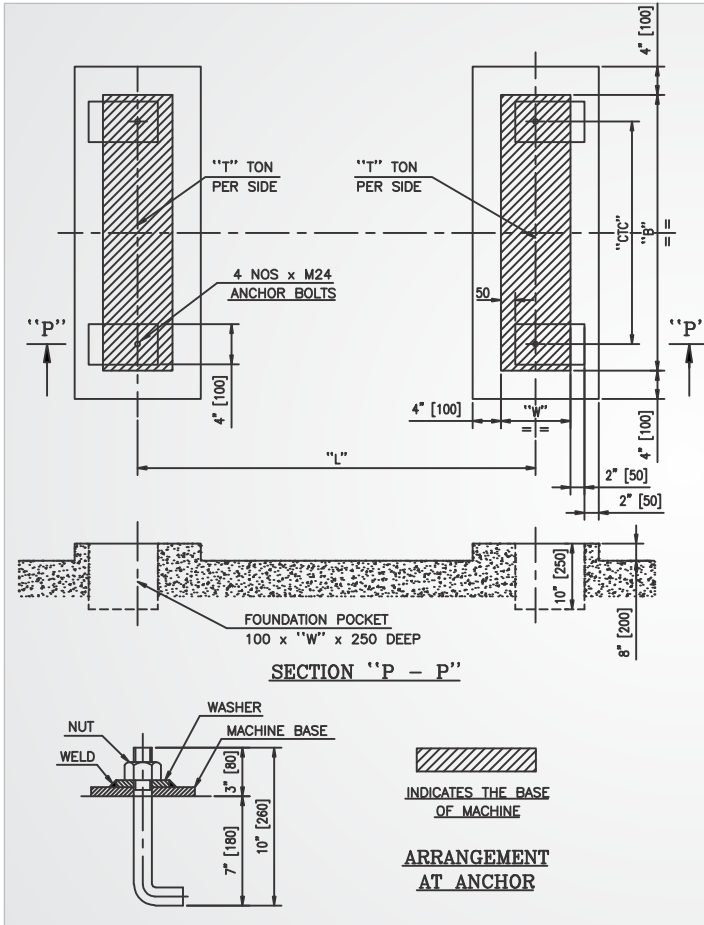

MODEL	"L"		"W"		"B"		"CTC"		"T"	
	mm	Inch	mm	Inch	mm	Inch	mm	Inch	TON	Pound
2B 2K	1846	73	220	09	1150	45	1046	41	3.3	7275
2B 2L	1846	73	220	09	1150	45	1046	41	3.4	7496
2B 2M	2866	113	220	05	1150	45	1046	41	4.0	8818
2B 2N	2866	113	220	09	1150	45	1046	41	4.1	9039
2B 3K	2866	113	220	09	1315	52	1214	48	5.0	11023
2B 3L	2866	113	220	09	1315	52	1214	48	5.1	11244
2B 3M	3474	137	220	09	1315	52	1214	48	5.8	12787
2B 4K	3474	137	220	09	1475	58	1374	54	6.9	15212
2B 4L	3474	137	220	09	1475	58	1374	54	7.2	15873
2B 4M	3474	137	220	09	1475	58	1374	54	7.4	16314
2B 5K	3424	135	270	11	1635	64	1534	60	8.7	19180
2B 5L	3424	135	270	11	1635	64	1534	60	8.9	19621
2B 5M	4374	172	320	13	1635	64	1534	60	10.8	23810
2B 5N	4374	172	320	13	1635	64	1534	60	11.1	24471
2B 6K	5826	229	320	13	1780	70	1610	63	13.9	30644
2B 6L	5826	229	320	13	1780	70	1610	63	14.3	31526
2B 7K	5724	225	425	17	2355	93	2184	86	20.3	44754
2B 7L	5724	225	425	17	2355	93	2184	86	20.8	45856
2B 7M	5724	225	425	17	2355	93	2184	86	21.5	47399
2B 8K	5724	225	425	17	2545	100	2374	93	25.0	55116
2B 8L	5724	225	425	17	2545	100	2374	93	25.6	56438
2B 8M	6974	275	425	17	2545	100	2374	93	29.0	63934
2B 8N	6974	275	425	17	2545	100	2374	93	29.8	65698

### Notes:

The above drawing indicate the dimensions of the equipment base frame and foundation bolt pockets and suggested size of the footings. The foundation shall be designed to suit the soil conditions and other design considerations at site.

# Typical Machine Illustration

NOZZLE SCHEDULE		
NOZZLE	NOZZLE FL. RATING	DESCRIPTION
N1	ASA 150	CHILLED WATER INLET
N2	ASA 150	CHILLED WATER OUTLET
N3	-	CHILLED WATER DRAIN PLUG
N4	ASA 150	COOLING WATER INLET
N5	ASA 150	COOLING WATER OUTLET
N6	-	COOLING WATER DRAIN PLUG
N7	ASA 150	STEAM INLET
N8	ASA 150	CONDENSATE OUTLET

### NOTES :

- ◆ INDICATES THE POSITION OF ANCHOR BOLTS.
- ↑ INDICATES THE POSITION OF THE POWER SUPPLY CONNECTION ON CONTROL PANEL
- MINIMUM INSTALLATION CLEARANCE.  
CONTROL PANEL SIDE : 1250 mm (50")  
TOP : 200 mm (8")  
OTHERS : 500 mm (20")

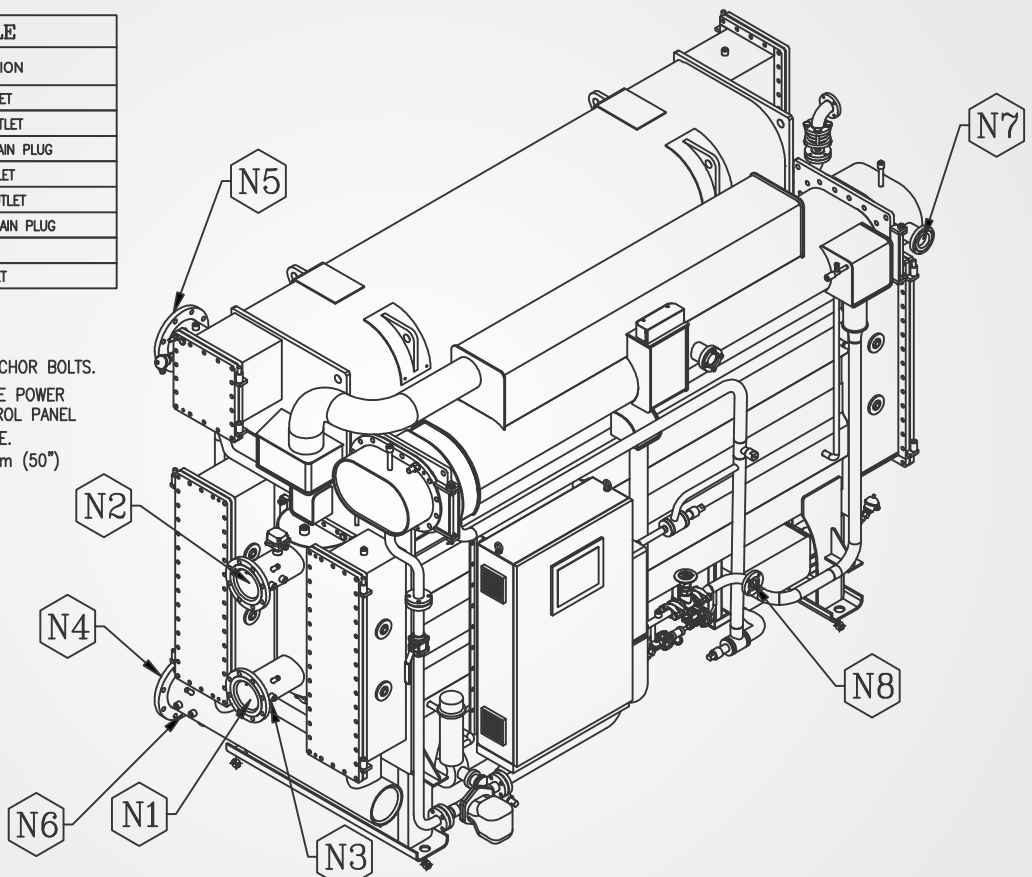

# Piping and Instrumentation Guidelines

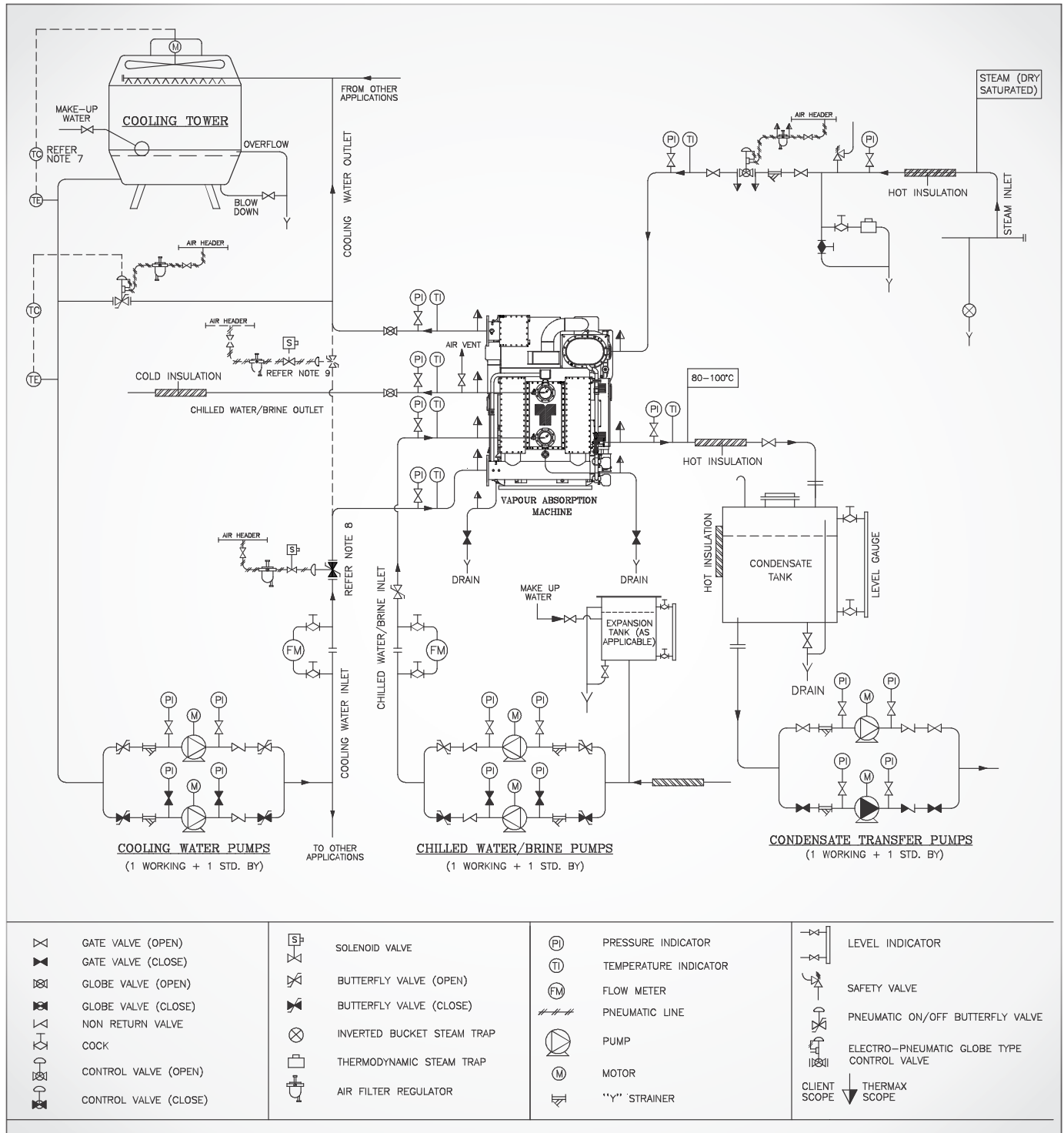

## Notes:

- Pressure reducing station and a safety valve to be provided on steam inlet line, if the design / operating pressure is more than 150 Psig.
- De-superheating to be installed on steam inlet line if the degree of superheat of steam exceeds 25°F.
- The back pressure in the condensate drain line should not be more than 390 inch H<sub>2</sub>O.
- Automatic arrangements should be provided to stop cooling water flow through the machine, if the chilled water/brine flow stops.
- Maximum working pressure in water headers is 115 Psig. This should be noted for design of chilled brine and cooling water system.
- Clean & dry compressed air supply to the instruments to be 70 Psig.
- Necessary arrangements to be made to maintain constant cooling water inlet temperature to chiller. Minimum allowable cooling water inlet temperature is 50°F.
- Install automatic shut off valve on the cooling water inlet line, if cooling water pumps are not dedicated to the machine.
- If cooling water pumps are dedicated to the machine and chilled water/brine temperature is < 40°F install cooling water automatic shut off valve only on the bypass line between cooling water inlet and outlet.

## References



### Refinery & Petrochemical

- Exxon Mobil, Saudi Arabia
- Reliance Industries, India
- Sipchem, Saudi Arabia
- IOCL, India

### Metals

- Tata Steel, India
- Bhilai Steel Plant, India
- Concord Steel, Brazil
- Maklada Prestressed Steel, Tunisia



### Pharmaceuticals

- Astrazeneca, UK
- Pfizer, India
- Johnson & Johnson, USA
- Glaxo Smithkline, India

### Paper & Packaging

- Phoenix Pulp And Paper, Thailand
- BILT, India
- Double A Paper, Thailand
- TNPL, India



### Food & Beverage

- Nestle, Philippines
- Cadbury, Nigeria
- Ferrero, Italy
- Coca Cola, India

### Textile

- Envoy Textiles, Bangladesh
- Indorama, Thailand
- Raymonds, India
- Garden Silks, India



### Chemical

- SFCCL, Saudi Arabia
- Aditya Birla Chemicals, India
- Eka Chemicals, China
- Tata Chemicals, India

### Commercial Centers

- BBC Studio, UK
- Revel Casino, USA
- Henry Ford Museum, USA
- Lotus TESCO, Thailand



## Contact Us



**THERMAX**

Sustainable Solutions in  
Energy & Environment  
**Cooling & Heating Division**

D-13 MIDC Chinchwad, Pune 411 019, India.  
Tel.: +91 -20-2747 5941 Fax: +91-20-27475907  
Email: acdmktg@thermaxindia.com  
Website: www.thermaxindia.com  
Customer: 1800 2090 115

### INDIA OFFICES

**Mumbai:** Tel: (022) 67542222, Fax: (022) 22040859  
**Ahmedabad:** Tel: (079) 26575408, Fax: (079) 26577270  
**Savli (Vadodara):** Tel: (02667) 264727, Fax: (02667) 264728  
**New Delhi:** Tel: (011) 46087200, Fax: (011) 26145311  
**Chennai:** Tel: (044) 24303400, Fax: (044) 24353841  
**Bangalore:** Tel: (080) 22371721, Fax: (080) 22371726  
**Hyderabad:** Tel: (040) 23310254, Fax: (040) 23312335  
**Kolkata:** Tel: (033) 22826711-3, Fax: (033) 22826796

### OVERSEAS OFFICES

#### Thermax Inc., USA:

Tel: +1-248-207-9959, Fax: +1-248-468-0546  
Email: rsinha@thermax-usa.com, www.thermax-usa.com

#### Thermax Europe Ltd., UK:

Tel: +44-1908-378914, Fax: +44-1908-379487  
Email: dinesh@thermax-europe.com, www.thermax-europe.com

**Thermax (Zhejiang) Cooling & Heating Engg. Company Ltd.** - China. Tel: +86-18-667375588, Fax: +86-21-64483997  
Email: vbalasub@thermax-china.com, www.thermax-china.com

#### Thermax Ltd, Russia

Tel: +7-495-434-30-41, Fax: +7-495-434-46-58  
Email: vikastripathi@thermaxindia.com

#### Thermax Ltd., UAE:

Tel: +971-4-8816481, Fax: +971-4-8816039

Email: navas@thermaxme.com, mohsin.pathan@thermaxindia.com

#### Thermax Ltd, Saudi Arabia

Tel: +966 55533 9762  
Email: mohsin.pathan@thermaxindia.com, navas@thermaxme.com

#### Thermax Ltd, Kenya

Tel: +254-726 729812, Fax: +254-20-4451919  
Email: nawzar@yahoo.com, mohsin.pathan@thermaxindia.com

#### Thermax Ltd, Nigeria

Tel: +254-726 729812, Fax: +254-20-4451919  
Email: nawzar@yahoo.com, mohsin.pathan@thermaxindia.com

#### Thermax Ltd, Thailand

Tel: +628159803103, Email: bharat@thermaxindonesia.co.id

#### Thermax Ltd, Malaysia

Tel: +628159803103, Email: bharat@thermaxindonesia.co.id

#### Thermax Ltd, Indonesia

Tel: +628159803103, Email: bharat@thermaxindonesia.co.id

#### Thermax Ltd, Philippines

Tel: +628159803103, Email: bharat@thermaxindonesia.co.id

#### Thermax Ltd, Bangladesh

Tel: +88-01-912008883, Email: mvreddy@citech-bd.com

#### Thermax Ltd, Sri Lanka

Tel: +91 98500 80012, Email: harishr@thermaxindia.com

### Thermax Business Portfolio

Water & Waste Solutions

Air Pollution Control

Chemicals

Boilers & Heaters

Absorption Cooling

Captive Power

www.thermaxindia.com

**Disclaimer:** In view of the constant endeavour to improve the quality of products, we reserve the rights to alter or change specifications without prior notice.