

# CM<sup>®</sup>

# SHOPSTAR<sup>®</sup> VS

VARIABLE SPEED ELECTRIC CHAIN HOIST



**CAUTION**  
IMPROPER ORIENTATION OF LOAD CHAIN ON LIFTWHEEL WILL  
CAUSE HOIST AND CHAIN DAMAGE.  
LOADS ON CHAIN MUST BE DOWN AND SQUARE TO WHEEL TO  
ENSURE PROPER OPERATION. REFER TO MANUAL FOR INSTALLATION  
AND PREVENTING OF LOAD CHAIN.

CM ShopStar VS shown with optional  
lug mount suspension and Universal Trolley



# SHOPSTAR<sup>®</sup> VS

## VARIABLE SPEED ELECTRIC CHAIN HOIST

The CM<sup>®</sup> ShopStar VS<sup>™</sup> variable speed electric chain hoist is built for rugged industrial and commercial applications where precision load control is critical. This durable hoist features a high H4-plus duty cycle and a compact design ideal for use at workstations and production lines. The ShopStar VS is a superior alternative to air hoists.

**CAPACITIES: 250 TO 1,100 LB.**

**STANDARD LIFT: 10 FEET**  
**SPEEDS: UP TO 63 FT./MIN.**

### BENEFITS & FEATURES

#### RUGGED & DURABLE

Thermally protected hoist motor. Rugged, cast aluminum alloy hoist frame and body feature durable epoxy powder-coat finish to protect against corrosion.

#### LOW MAINTENANCE

Gear train lifetime lubricated with non-oxidizing grease. Totally enclosed hoist frame protects motor from environmental contamination.

#### COMPACT DESIGN

Small, compact design makes hoist ideal for use in tight spaces and allows for easy installation and maintenance.

#### OVERLOAD PROTECTION

Standard overload device protects the hoist, operator and surrounding structure from damaging overloads.

#### LONG CHAIN LIFE

Durable CM Hoistaloy<sup>®</sup> Load Chain. 10-pocket, oblique-lay lift wheel for longer chain life.

#### SINGLE- & 3-PHASE VOLTAGE OPTIONS

100 to 240 volt single phase, 50 to 60 Hz.  
208 to 240 volt 3 phase.  
460 volt and 575 volt 3 phase with optional transformer.  
6-1/2 ft. power cord with removable molded, 3-prong 115-volt plug.

#### H4 PLUS DUTY CYCLE

With 300+ motor starts per hour and Class F motor insulation, the ShopStar VS outperforms the H3 rating of its major competitors.

#### 5:1 DESIGN FACTOR

#### NEMA 4 INDUSTRIAL-RATED CONTROL SYSTEM

#### STANDARD RIGID-HOOK SUSPENSION



### OPTIONAL FEATURES

#### CM<sup>®</sup> ROCKET<sup>™</sup> PENDANT

Engineered for maximum operator comfort, the CM Rocket delivers precision load control. Pendant features a unique rocker switch and comfort-fit design that increases safety and efficiency. Not available for 3-step infinitely variable hoist models. Pendant with emergency stop not available on ShopStar VS.



#### VARIABLE CONTROLS

Choose from 2-speed, 2-step infinitely variable, 3-speed and 3-step infinitely variable controls for single and 3-phase applications.

#### DURABLE CHAIN CONTAINERS

Impact-resistant plastic/mesh or metal chain containers.

#### SWIVEL HOOK SUSPENSION

Swivel hook suspension rotates 360° for easy installation and positioning. Swivel hooks are available with latch and Latchlok<sup>®</sup> latch. Lug mount suspension is also available.





CM ShopStar VS shown with optional chain container.



# CM SHOPSTAR VS SPECIFICATIONS & DIMENSIONS

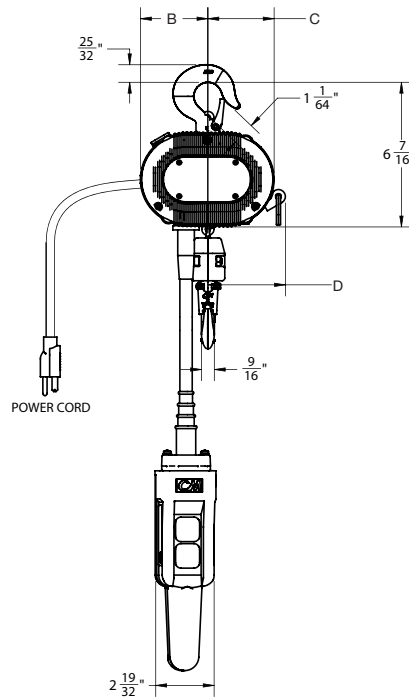
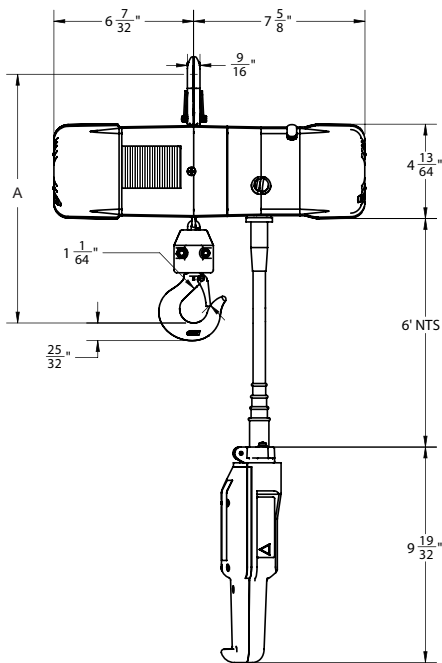

Capacity (Metric Tons)	Product Code				Dimensions in. (mm)				Maximum Lift Speed (ft./min.)	Standard Lift (ft.)	Reeving	Weight (lb.)
	2-Speed	2-Step Infinity Variable Speed	3-Speed	3-Step Infinity Variable Speed	A	B	C	D				
250	VS0250A1	VS0250A2	VS0250A3	VS0250A4	11.06	3	2.95	3.45	63	10	1	26
300	VS0300A1	VS0300A2	VS0300A3	VS0300A4	11.06	3	2.95	3.45	63	10	1	26
500	VS0500A1	VS0500A2	VS0500A3	VS0500A4	11.06	3	2.95	3.45	39	10	1	26
550	VS0550A1	VS0550A2	VS0550A3	VS0550A4	11.06	3	2.95	3.45	26	10	1	26
600	VS0600A1	VS0600A2	VS0600A3	VS0600A4	11.94	3.58	2.36	2.87	31	10	2	28
1000	VS1000A1	VS1000A2	VS1000A3	VS1000A4	11.94	3.58	2.36	2.87	19	10	2	28
1100	VS1100A1	VS1100A2	VS1100A3	VS1100A4	11.94	3.58	2.36	2.87	13	10	2	28

NOTE: Configurable codes and options available in addition to standard products shown above. Optional transformer required for 460-volt applications.



## THE IDEAL WORKSTATION HOIST.

The CM ShopStar VS is ideal for applications in the Automotive, Heavy OEM, Utility and Energy industries. Choose this reliable hoist for light assembly workstations that require high speed and precision control lifting with light rail or trolley systems.

In addition, the ShopStar VS is perfect for maintenance and repair applications demanding accurate load control or long lifts.

# SHOPSTAR FAMILY SPECIFICATIONS AT A GLANCE

## THE CM SHOPSTAR VS BRINGS THE SPEED

The CM ShopStar electric chain hoist product line is known for its compact design and quiet operation. The ShopStar VS rounds out this popular portfolio with high-speed operation.

Capacities	SHOPSTAR		SHOPSTAR VS	
	Speed (FPM)	Reeving	Min - Max Speeds (FPM)*	Reeving
250 lb.	16, 24, 40	1	3 to 63	1
300 lb.	16, 24, 40	1	3 to 63	1
500 lb.	8, 12, 16, 20, 24	1 & 2	2 to 39	1
550 lb.	—	—	1 to 26	1
600 lb.	8, 12, 20	2	2 to 31	2
1000 lb.	6, 8, 12	2	1 to 20	2
1100 lb.	N/A	—	1 to 13	2
<b>Totally Enclosed Non-Vented Motor</b>	Standard		Standard	
<b>Load Chain</b>	Standard Unplated / Optional Plated		Standard Unplated / Optional Plated	
<b>Chain Container</b>	Optional		Optional	
<b>Powder Coat Paint</b>	Standard		Standard	
<b>Available Voltages</b>	115 to 230V Single Phase. 208 to 575V 3-Phase		100 to 240 volt single phase. 208 to 240 volt 3 phase. 460 volt and 575 volt 3 phase with optional transformer.	
<b>Variable Frequency Drive Versions</b>	N/A		Standard	
<b>Two-Speed Version</b>	N/A		Standard	
<b>CM® Rocket™ Pendant</b>	Engineered Special		Standard Option (Not available for 3-step infinitely variable models.)	
<b>Certification</b>	CUL		CUL (pending)	
<b>Motor Brake</b>	DC		DC	
<b>Motor Insulation</b>	Class B		Class F	
<b>Mechanical Load Brake</b>	N/A		N/A	
<b>Upper Suspension</b>	Rigid Hook Standard		Rigid Hook Standard	
<b>Suspension Option</b>	Hook and Lug		Hook and Lug	
<b>Overload Clutch</b>	Standard		Standard	
<b>Metric Rated</b>	Standard		Standard	
<b>Warranty</b>	Lifetime		Lifetime	
<b>Country of Origin</b>	USA		USA	

\*Configurable codes and options available in addition to standard products.

## MAXIMUM CONTROL. MINIMAL EFFORT.

The CM® Rocket™ pendant is available as a standard option on the CM ShopStar VS. At the heart of the CM Rocket is a unique rocker switch that is ergonomically designed to reduce thumb strain and fatigue. The rocker switch gives the operator ultimate load control for micro-positioning applications, as well as increased safety and efficiency for hoist operators. Its curved, well-balanced shape and ribbed grip help ensure the operator maintains a secure and comfortable hold.



# THE SHOPSTAR VS: A SUPERIOR ALTERNATIVE TO AIR HOISTS

## Lower Operating Costs

### MORE EFFICIENT POWER CONSUMPTION

Unlike the ShopStar VS electric hoist, air hoists require inefficient and costly electric or diesel-powered air compressors.

### LESS DOWNTIME

Electric hoists are easier and less expensive to maintain compared to air hoists that require regular oil changes; maintenance to the filter, regulator and lubricators (FRLs); and replacement of the vane, seal and gasket.

### LOWER INSTALLATION COSTS

The ShopStar VS is up to 30% lighter than air hoists, installs in minutes with simple electric setup and does not require an air source, exhaust system, or additional startup and maintenance costs for an in-line lubricator or filter.

## Cleaner Operation

Unlike electric hoists, air compression systems require oil-lubricated air that is expelled into the environment with hoist's exhaust air.

## Quieter Operation

Electric hoists are considerably quieter compared to air hoists.

## More Responsive Controls

The reaction time of the ShopStar VS is more responsive than an air hoist that has lag time due to long control lines and circuit pressurization.

“ We converted to the ShopStar because of its speed, dependability and braking system. It made our process much more efficient by switching over.”

– Greg Zippadelli, Competition Director, Stewart-Haas Racing



## THE POWER OF INTELLIGENT LIFTING

Since 1875, Columbus McKinnon has helped to make material handling easier and safer, and, today, is your single source for complete floor-to-ceiling lifting systems.

From below-the-hook attachments, chain, rigging products, manual and powered chain hoists to electric wire rope hoists, cranes, enclosed track systems and specially engineered products, Columbus McKinnon has the engineering expertise to meet the most demanding applications.



## KNOW HOW. KNOW WHY.

Columbus McKinnon is committed to providing expert safety training on the proper use and inspection of rigging and overhead lifting equipment. Our company offers comprehensive programs at our national training centers as well as on-site at your facility. Courses include:

- Hoist Maintenance
- Safe Hoisting
- Rigging Gear Inspection
- Crane & Hoist Inspection
- Load Securement
- Crane Operator Training
- Rigging

Win in the marketplace with **CMCO University™**. This three-day program is designed to give Channel Partners intimate product and application knowledge that they can use to advise their end-user customers during the product selection and sales processes.



Columbus McKinnon's corporate headquarters in Getzville, New York, is home to our state-of-the-art **Niagara Training Center**. The 3,000-square-foot facility is dedicated to training Channel Partners and end users on the safe and proper use of hoist and rigging products. The Center offers a one-of-a-kind training experience on chain and rigging equipment with more than 75 manual and powered hoists, enclosed track systems and our 50-foot-wide crane system with 3-ton Yale Global King wire rope hoist.



USA 800.888.0985 • 716.689.5400 • fax: 716.689.5644

[www.cmworks.com](http://www.cmworks.com)

