

VARIABLE SPEED FLUID COUPLINGS DRIVING CENTRIFUGAL COMPRESSORS AND OTHER CENTRIFUGAL MACHINERY

by

Gunther H. Peikert

Regional Manager

Voith Transmissions, Incorporated

Houston, Texas

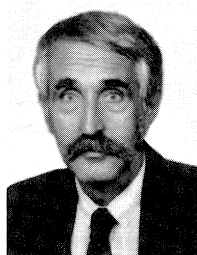

Gunther H. Peikert received his degree in Mechanical Engineering at the Technical University of Kaiserslautern in West Germany. He joined Voith in 1963 and worked for five years in the Research Department for Hydrodynamic Fluid Couplings. Since 1968, he has assumed several international assignments for Voith in France, Spain, and the United States.

Mr. Peikert has been in Houston since 1981 as the Regional Manager for Voith Transmissions, the U.S. subsidiary of Voith's Power Transmission Departments.

ABSTRACT

In the past, large compressors in the petrochemical industry were mostly driven in one of two ways: by steam (or gas) turbines or by constant speed electrical motors. If the flow of the compressor had to be controlled, two ways were possible: to control its speed or to control its suction. If flow control was required, the steam (or gas) turbine was the right answer, since in-plant steam could be produced at a rather low cost (gas could be purchased for an equally low price). In the case of more continuous, even flow rates, the constant speed electric motor was a good alternative. For startup, the compressor was bypassed and, if a certain control was necessary, suction control was used without even looking at the power consumption. Highly increased fuel cost, especially for in-plant steam generation, has made commercially available electric power from large generating plants more attractive. On the other hand, for the same reason, energy conservation makes speed control much superior to suction control and last, but not least, the more diversified nature of feed stocks as well as more fluctuating production rates call more often for compressors to be controlled. The same is valid for other centrifugal machines such as boiler feed water pumps and pipeline loading pumps.

Today, more and more compressors are driven by variable speed devices other than steam turbines. One way is to use purely electric drives, which are, however, still in the trial phase regarding large horsepower. Another, much more proven way is to use, in connection with a standard constant speed electric motor, a hydrodynamic, so-called, fluid coupling. The type of fluid coupling mostly used for this application is the one with integrated gears.

This kind of machine, relatively new to the petrochemical community, has, however, proven its high reliability and availability in thousands of applications in the power generating industry, mostly with boiler feed pumps. Other applications have included installations in oil producing and shipping plants, on platforms offshore and onshore, and with pipeline and loading pumps. Successful compressor applications go

back some 15 years, with numbers increasing over the last three to four years. These compressor applications go up to 10,000 hp, with output speeds reaching 12,000 rpm. Pump applications with many more years of case history exist up to 30,000 hp, with designs available for 60,000 hp.

There are many more applications of the hydrodynamic principle in numerous other industries, in the form of fluid couplings and torque converters, as well as combined transmissions.

The intention herein is to describe the hydrodynamic principle and its technical application in the following areas:

- Basic function of hydrodynamic variable speed fluid couplings
- Advantages of using such couplings
- Successful designs of such couplings
- Typical applications with centrifugal machines
- Speed control options and instrumentation
- Economic advantages of speed control
- Installation and maintenance
- Reliability and availability
- Other types of variable speed drives

Thousands of variable speed fluid couplings in pump and compressor applications worldwide have proven the high degree of availability, the simple maintenance needs and the long life of such wear-free machines.

BASIC FUNCTION OF HYDRODYNAMIC VARIABLE SPEED FLUID COUPLINGS

The hydrodynamic principle of power transmission was discovered and developed by Professor Foettinger in the early part of this century. His basic idea was to integrate a pump and a turbine, both centrifugal, in the same machine (Figure 1). The transmission fluid, usually a mineral oil, is accelerated in the pump wheel, and goes then over into the turbine wheel, where it is decelerated (Figure 2). In other words, in the pump wheel, also called the primary wheel, the mechanical energy from the driver is converted into kinetic energy, which in turn is reconverted into mechanical energy in the turbine wheel, also called the secondary wheel, now turning the driven machine. The geometrical form of both wheels as well as the form and distribution of the radial blades within these wheels reflects the knowledge and experience of the manufacturer of hydraulic machines.

This principle of hydrodynamic power transmissions applies to all kinds of fluid couplings, whether they are constant speed, drain type or variable speed type. The first group is mostly used for soft starts, overload protection and gentle acceleration. The second type is also used to separate the driven machine from the driver, like a clutch, without losing the advantages of the first group.

The third group, variable speed fluid couplings, is the subject herein. In order to obtain the different speeds required against a given load (i.e., the parabola of a centrifugal pump),

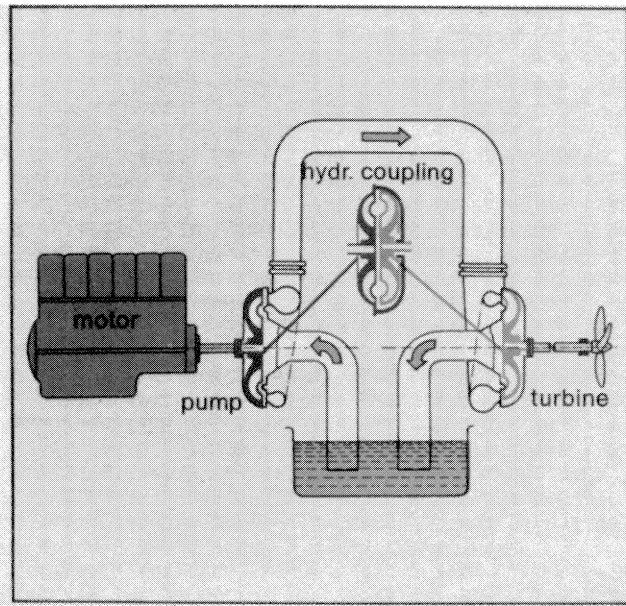

Figure 1. Foettinger Principle.

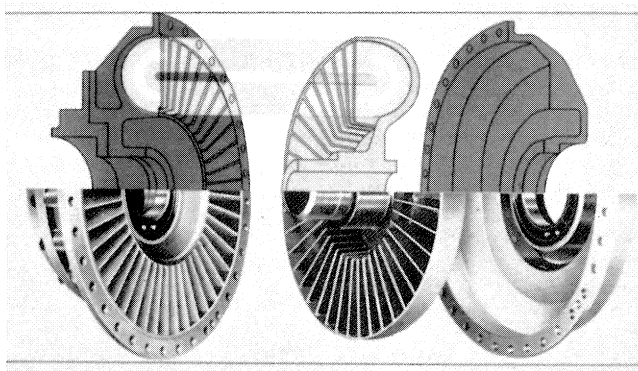

Figure 2. Hydrodynamic Power Transmission.

the variable speed coupling has to be adjusted in its filling so as to change its torque versus speed characteristic (Figure 3). This is basically done by superimposing an oil flow on the above described oil circulation between the primary and the secondary wheels (Figure 4). In most fluid couplings this is done by supplying an oil flow, which can be constant for smaller units, but should be variable (dependent of the occurring heat load in the coupling) for larger units, into the active part (bladed pump and turbine wheel sections) of the fluid coupling.

Control of the degree of filling is obtained by introduction of a variable overflow, which is in this case a so-called scoop tube. The scoop tube is a more or less radially located tube which has a curved opening directed against the direction of rotation of the spinning oil ring within the coupling. It usually runs in a separate annular chamber, which is connected by axial bores within the active part of the fluid coupling, and which will have the same oil level, due to the centrifugal force in this working chamber.

The scoop tube is so designed and dimensioned that it can, under all working conditions, pump out more oil than the filling pump can supply. By this trick, the speed variation comes down to the simple, mechanical positioning of the scoop tube. A speed difference between the pump wheel and the turbine wheel always has to exist, in order to create a circular

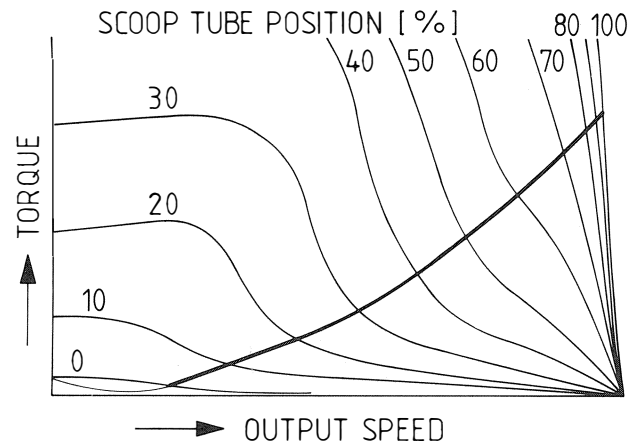

Figure 3. Torque—Speed Characteristic of Variable Speed Fluid Coupling.

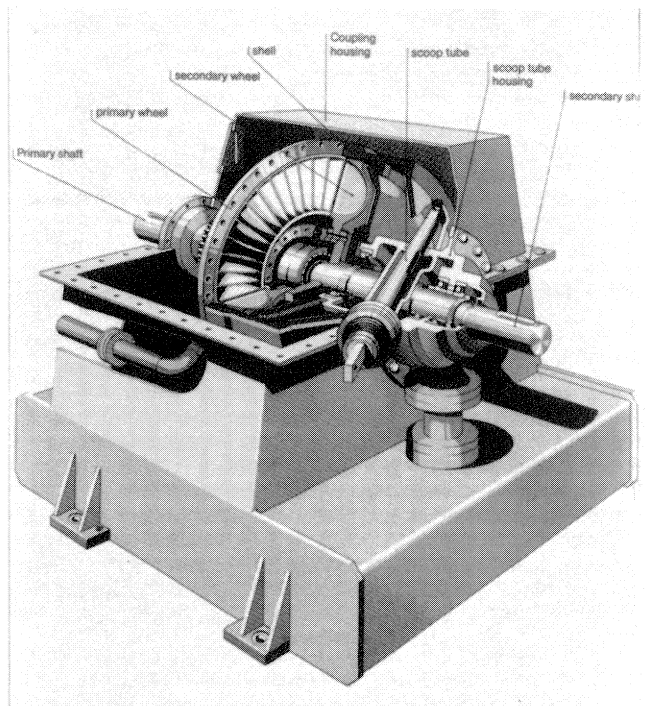

Figure 4. Simple Cut-Away of a Variable Speed Fluid Coupling.

oil flow between those two parts, by the difference in the centrifugal forces, and so be able to transmit torque. The speed difference between the pump wheel and the turbine wheel is called slip and is expressed in percent of the pump wheel speed. By inducing slip as the means of speed regulation, slip losses are created within the freely circulating transmission oil, which in turn can be very easily transported by this same oil through the scoop tube, out of the coupling and into a heat exchanger. After dissipating its heat either to water or to air, the cooled oil flows back into the fluid coupling.

ADVANTAGES OF VARIABLE SPEED COUPLINGS

- Load-free startup of driver
- Steplessly adjustable startup as well as stepless speed regulation

- Dampening of torque peaks (and no harmonics) from either side and thus,
- Decreasing mechanical stress in the whole drive line
- Disconnecting driven machine possible while driver keeps running
- Torque limitation capabilities
- Wear-free power transmission
- Extreme high availability
- Low maintenance needs
- Very versatile regarding necessary accessories and instrumentation, using standard models.

SUCCESSFUL DESIGNS OF SUCH COUPLINGS

For the purposes here, the multitude of existing couplings of these types can be divided into three basic families.

Variable Speed Fluid Couplings With Anti-Friction Bearings

The different couplings with anti-friction bearings are mostly used for small and medium horsepowers in what can generally be referred to as industrial applications (Figure 5). These couplings exist in both the horizontal as well as the vertical versions. The simplest type has its rotating parts supported by the driving and driven shafts. The other types are free standing, fully enclosed, with the housing being either of the barrel type or horizontally split. These couplings have a motor driven or mechanically driven oil pump, their scoop tube is directly linked to a mechanical actuator, and the hot oil flows into the sump. The oil cooler is normally located after the oil sump.

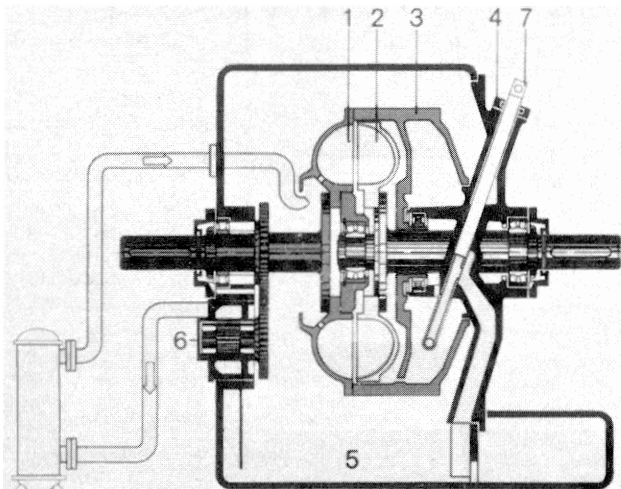

Figure 5. Variable Speed Fluid Coupling with Anti-Friction Bearings. 1) primary wheel, 2) secondary wheel, 3) shell, 4) scoop tube housing, 5) oil sump, 6) oil pump, 7) scoop tube.

Variable Speed Fluid Couplings With Sleeve Bearings

Variable speed couplings with sleeve bearings are used in the power generating and petrochemical industries (Figure 6). They also include both horizontal and vertical designs. One type is mostly used for low speed applications, and has basically the same features as the first group. The second design, for higher speed (mostly with two pole motors), is typically driving boiler feed pumps or compressors.

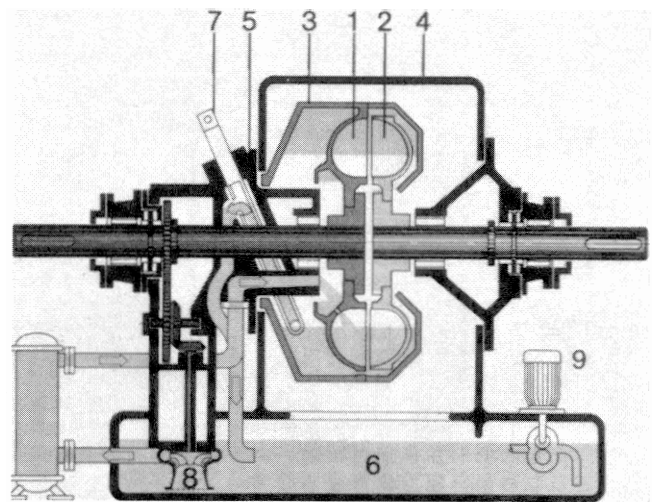

Figure 6. Variable Speed Fluid Coupling with Sleeve Bearings. 1) primary wheel, 2) secondary wheel, 3) shell, 4) coupling housing, 5) scoop tube housing, 6) oil sump, 7) scoop tube, 8) oil pump, 9) auxiliary lube pump.

This type shows two new features (Figure 7). The scoop tube is no longer linked directly to the actuator, but to an internal gear segment drive with a cam to be moved by the actuator. This produces a linear behavior for the fluid coupling, which means it can be adjusted in the plant to have a fully linear response to the input control signal. The other feature is a regulating valve which is mechanically linked to the scoop tube control. This valve recirculates the working oil directly back into the coupling, thus creating a closed circuit. In this case, the cooler is located after the scoop tube. The amount of oil circulation in this closed circuit is regulated by the valve as a function of the occurring heat losses, thus providing an even temperature level and lowering mechanical losses within the system.

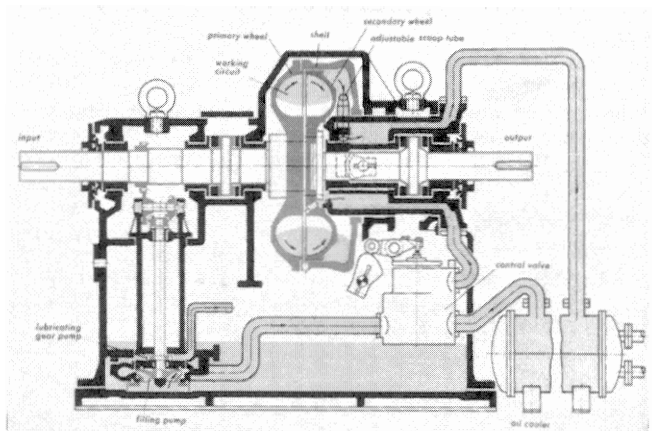

Figure 7. Variable Speed Fluid Coupling for Two Pole Electric Motor Applications.

Variable Speed Fluid Couplings With Incorporated Gears

Variable speed fluid couplings with incorporated gears are the workhorses for higher horsepowers and/or speeds, and combine variable speed couplings with sleeve bearings with one or two steps of gear sets, all included in one housing (Figure 8). It was basically developed for boiler feedwater pump applications, but has also been successfully used for

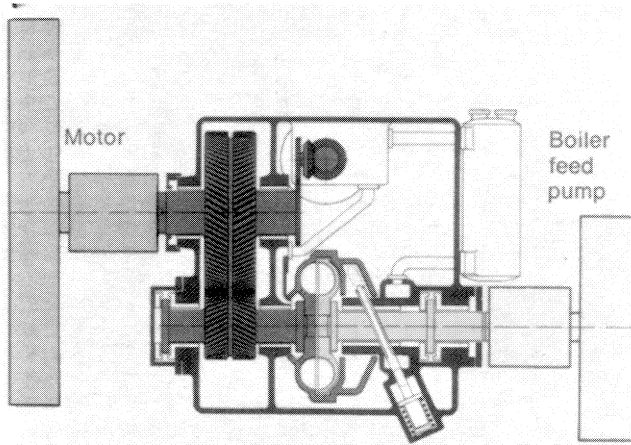

Figure 8. Typical Variable Speed Geared Fluid Couplings.

pipeline and loading pumps, fans, compressors and very recently for water injection pumps. This type of coupling includes a hydraulic cylinder moving the scoop tube, thus allowing the use of smaller actuators and such additional features as quick start or stop. More than 3,000 units of such drives, most of them in the 2,000 hp to 30,000 hp range, are running worldwide with output speeds between 900 rpm (fans) and 12,000 rpm (compressors). The use of this variable speed, geared fluid coupling allows the use of simple, standard two or better yet, four pole electric motors, matching most any compressor or pump speed, and results in a very compact, cost saving solution.

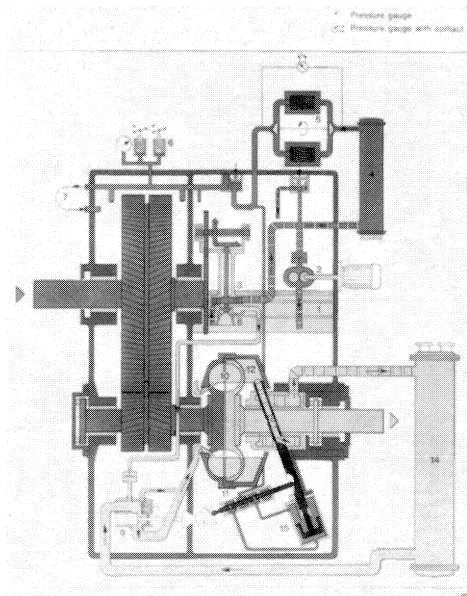
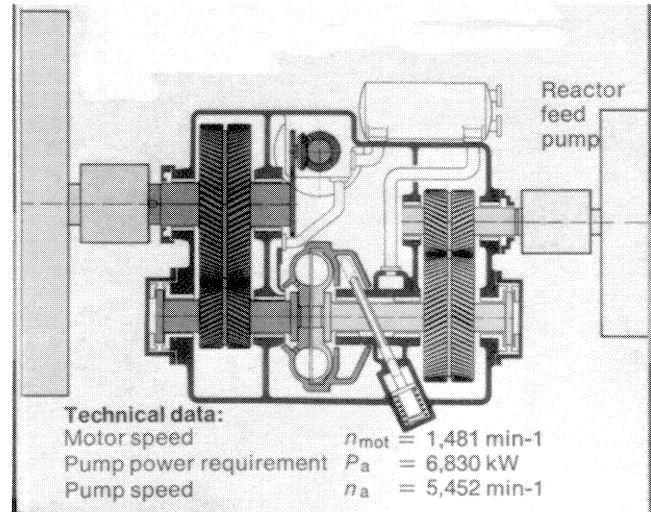

Figure 9. Variable Speed Geared Fluid Coupling-Basic Design. 1) oil sump, 2) auxiliary lube oil pump, 3) main lube oil pump, 4) lube oil cooler, 5) double filter, 6) pressure switches for auxiliary lube oil pump, 7) external lube oil for driving and/or driven machine, 8) working oil pump, 9) regulating valve, 10) working chamber (pump wheel + turbine wheel), 11) scoop tube governor, 12) scoop tube intake, 13) scoop tube, 14) working oil cooler, 15) hydraulic cylinder.



A schematic of a section cut through a standard geared variable speed fluid coupling with one step up gear set at the input side is shown in Figure 9. The working oil and the lube oil have separate systems, both using the same oil out of a common oil sump. The combined pump set is mechanically driven from the input shaft.

The working oil flows from the centrifugal filling pump into the flow control valve, from where it goes into the fluid coupling's active part to take care of the power transmission. During this process, its temperature increases. The now hot oil is removed through the scoop tube and pumped through the heat exchanger back to the flow valve. This system is a closed circuit, where the filling pump only circulates oil and maintains pressure. The lube oil pump, a positive displacement pump backed up by a motor driven startup and standby pump, is pumping oil through the lube oil heat exchanger and double filter into the lube oil system, which also provides, if necessary, external lube oil for the driver and the driven machines. It also provides the control oil for the hydraulic cylinder controlling the scoop tube. This design allows the use of small, compact actuators which only have to move the pair of cams controlling the hydraulic governor piston as well as the flow control valve.

Another type of variable speed fluid coupling (Figure 10) includes two different hydrodynamic circuits in one system, together with the appropriate gears, to cover two select parts of the speed range with even higher efficiency. In this coupling, the change from one circuit to the other is done in both directions, while running, without interruption of the power

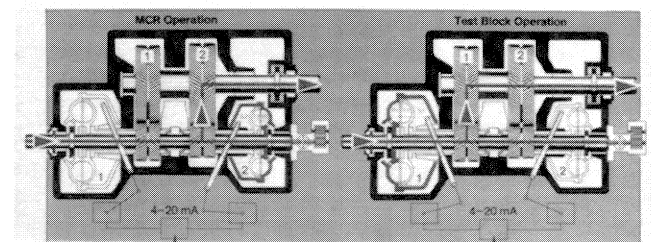

Figure 10. Double Circuit Variable Speed Geared Fluid Coupling.

transmission. To avoid pumping, speed changes are made at different speeds (going up at a higher speed, coming down at a lower speed).

TYPICAL APPLICATIONS WITH CENTRIFUGAL MACHINES

Centrifugal Compressors

Historically, most larger compressors in the petrochemical industry are either driven by turbines, or, when driven by electric motors, suction throttle controlled. Suction throttle (or bypass) control is no longer acceptable, due to the involved power losses. Steam turbines, once so well fitted to do the speed control, lose ground as the production of steam in small in-house power plants becomes more and more expensive. On the other side, electrical power can be purchased at a much more acceptable cost. This is where the geared fluid coupling has found a new field of application over the last years (Figure 11).

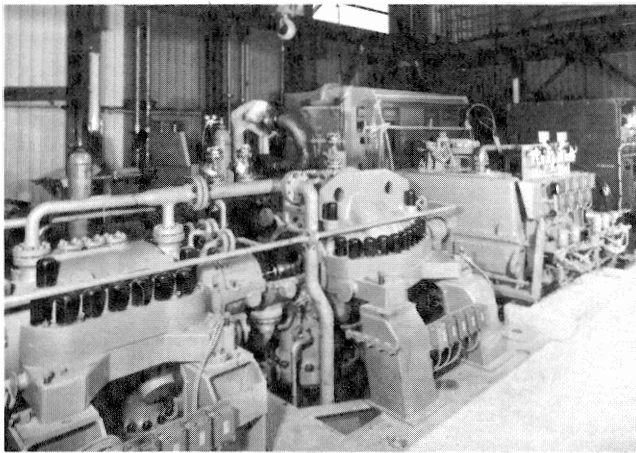

Figure 11. Variable Speed Geared Fluid Coupling Between Motor (4000 HP, 1490 RPM) and Ethylene Compressor (12,604 RPM).

The fluid coupling allows the use of simple, but highly efficient, electrical motors which can start basically unloaded. The fluid coupling itself is, by nature of its function, of explosion proof design. The fluid coupling does not produce any harmonics, and further, it also dampens any rotational vibrations by mechanically separating the driver from the compressor.

In addition to the standard design which has proven its high availability in several thousand applications, this type of coupling is also built to American Petroleum Institute (API) specifications as far as applicable. In this case, the gear part is calculated and manufactured following API 613, and the lube oil system following API 614.

Speed control is generally realized by using two pneumatic cylinders which are mechanically positioned in-line. The first one covers the startup range and is generally manually controlled. This allows a quick startup through the first critical speed of the compressor and the eventually needed regulation of the compressor speed during the establishing of a chemical process.

The second cylinder covers the remaining speed range which is needed for normal production. In this case, the 3 psi to 15 psi control signal can be spread out just for the production speed range, thus giving a very sensitive and exact means of control.

An additional feature of the fluid coupling is that in the very undesired case of a problem with a compressor, the motor can be disconnected very quickly by simple scoop tube action, thus reducing the ωR^2 of the system and decreasing the rundown time.

The main reasons to use a fluid coupling, and especially a geared fluid coupling, for the drive of a centrifugal compressor are:

- Use of a simple electric motor.
- Unloaded starting of the motor.
- Efficient speed regulation.
- No harmonics induced by the drive.
- Dampening of the rotational vibrations.
- High availability.
- Low maintenance.
- Simple function.
- Compact design.
- No specialist needed, in-house servicing without long expensive training.
- Explosion proof within itself.
- Easy to adapt to process needs.
- Versatile with regard to accessories and instrumentation.
- No back effects on electric supply lines (mains).
- No high peak torques after very short blackouts which do not trip the system.
- Competitive cost.

Boiler Feedwater Pumps

The main reason for utilizing fluid couplings for the boiler feedwater pump application is to provide speed regulation at the pump while using a simple constant speed electric motor. The fluid coupling (Figure 12) allows a nearly unloaded quick startup of this electric motor, thus reducing the time of high inrush current to a few seconds. If necessary, a quick start device in the fluid coupling's scoop tube control allows the pump to be brought to speed in eight to twelve seconds. The incorporated gears of the coupling allow the pump manufacturer to design the pump for best efficiencies. The use of speed regulation permits the user to operate the pump at better efficiency values for changing flows, and also reduces wear and noise and increases the lifetime of the pump.

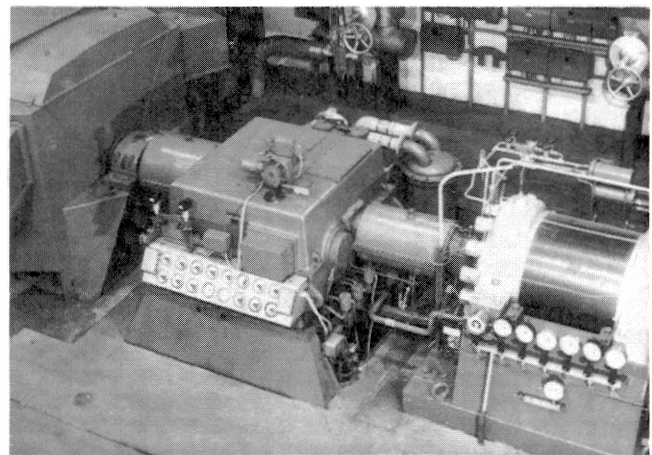

Figure 12. Variable Speed Geared Fluid Coupling Driving Boiler Feedwater Pump (13,200 HP, 4850 RPM).

Loading Pumps

For loading pumps, flow variation is needed to adjust to changes in suction pressure (tank levels) and load curves,

depending on the tanker's intake system and capacity. In addition, the fluid coupling also can be used to bring the pump to a stop with the main motor running, thus decreasing the number of starts for large electric motors.

SPEED CONTROL OPTIONS AND INSTRUMENTATION

Speed Control

Only for some very few simple applications is a manual control via lever (with locking device) or self-locking hand-wheel spindle drive sufficient for speed control. The bulk of industrial and power generation applications need at least an electromechanical actuator (pneumatic actuator option for the petroleum-related industry) with feedback for position control, with additional signalling contacts and end stops, together with a speed measuring and monitoring device. For more complex situations, a positioning controller can also be supplied, which will follow a signal from the customer's main controller. As additional features, quick startup or stop devices can be included in the speed control.

Instrumentation

Standard instrumentation for fluid couplings (Figure 13) includes oil temperature and pressure instruments for smaller units, and additional bearing temperature thermometers and pressure switches for larger units, as well as differential pressure switches for double filters where applicable. For more stringent applications, frequent options are RTDs or thermocouples in all bearings and oil lines, vibration and acceleration probes with the necessary accessories, oil level switches and more.

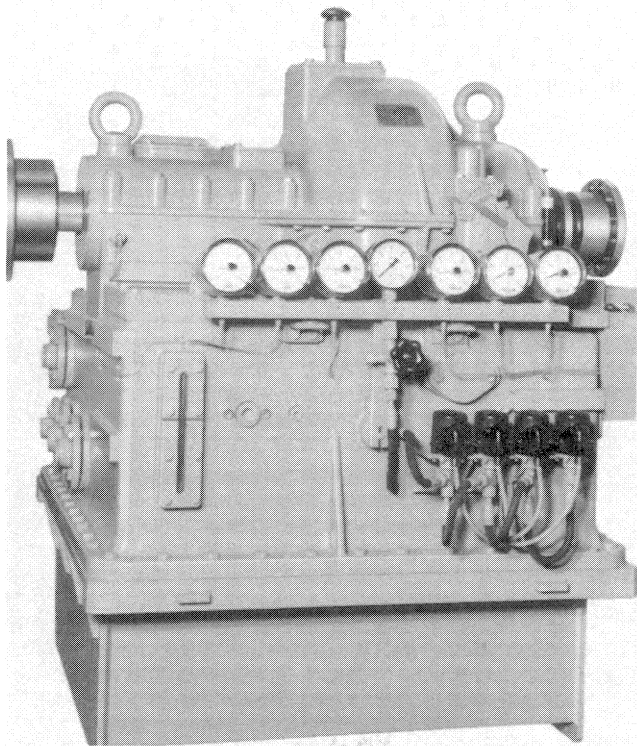

Figure 13. Example of Instrumentation for Variable Speed Fluid Coupling.

Options

When specifications are not met by the standard unit, the following options are available:

- Gear parts meeting American Gear Manufacturers Association (AGMA) and/or API 613 specifications.
- Fluid couplings without their own lube oil systems, can be connected to common, oil supply units which generally conform to API 614 specifications.
- If space is restricted, fluid couplings can utilize a flat sump with a separate oil tank.
- Sump heaters.
- Double heat exchanger systems with solenoid valves.
- Mirror-image geared variable speed fluid couplings for retrofits.

ECONOMIC ADVANTAGES OF SPEED CONTROL

In comparison with the still widely used throttle control, substantial energy savings can be realized using speed control for the drive of centrifugal pumps. The somewhat higher investment can be paid back within a relatively short term (one to two years), in most cases. Throttle valves are also exposed to high wear, whereas speed control diminishes wear in the pump for obvious reasons.

In a very conservative example, which was based on the following assumptions

- 50 hours at 100 percent flow,
- 5,000 hours at 89 percent flow,
- 2,800 hours at 71 percent flow,

the energy savings for speed control versus throttle control came to approximately one hundred thousand dollars per year, not speaking of reduced wear, lower noise levels and other advantages of the use of variable speed fluid couplings. Lang and Rees detail this example.

For compressor drives, variable speed couplings have also shown substantial savings, compared with suction control or turbine drives. In a recent case, which has been operating for several months, the complete cost of a retrofit from steam turbine to constant speed electric motor-variable speed fluid coupling, including completely new foundations, will be recovered within three years. If an existing foundation can be modified, the return time might be even lower.

INSTALLATION AND MAINTENANCE

During first installation, the usual care has to be taken to align motor, fluid coupling and driver, taking into consideration the heat growth from ambient to operating temperatures. Necessary pipe connections for the cooling system have to be mounted free of stress, and be pickled, neutralized and flushed prior to connection to the fluid coupling after final alignment.

Maintenance is mainly limited to the monitoring of instruments. At indicated intervals, oil levels have to be controlled and filters checked and changed over and cleaned, if necessary. After more frequent checks initially, oil checks and eventual oil upgrading or changing are limited to once a year. Eventually, the existing grease programs of the actuators have to be followed.

RELIABILITY AND AVAILABILITY

Due to the wear-free power transmission and the absence of any complicated mechanical or electronic components, a well designed fluid coupling does provide excellent reliability and availability. For straight type fluid couplings with anti-friction bearings, 361 units were observed for a period of five years. A Mean Time Between Failures (MTBF) of 113,150

hours resulted from 2,828,700 operating hours with 25 failures.

In a petrochemical plant, three screw compressors are driven with such couplings. Two of these units have run continuously since 1970, with loads between 75 percent and 100 percent. When the compressors are overhauled every 18 months, the oil in the fluid couplings is changed. Over one hundred thousand hours have been accumulated without a need to use the third (standby) unit.

For 52 other units using straight through fluid couplings with sleeve bearings, two failures were observed in the period between 1968 and 1979. The calculated MTBF is 217,000 hours.

For the variable speed geared couplings, fifty-seven units with powers between 11,500 kW and 20,000 kW have been observed. Two failures were experienced in the time between 1971 and 1979. The resulting MTBF is 273,600 hours. The repair of these failures was done in four days at ten hours for each repair. The average operating time of these units was 5.05 years at the time of this study.

OTHER TYPES OF VARIABLE SPEED DRIVES

Hydroviscous drive systems, often mistakenly called fluid couplings, have for very fundamental reasons a more complicated, and thus less reliable, control mechanism. Instead of simply positioning a scoop tube, they have to continuously hold a balance between the oil film pressure in a rotating stack of clutch faces, and the counteracting clamping force. Heat is created, like in any other slip device (be it fluid coupling or Eddy current coupling), but for this type of drive, heat is generated in a thin oil film which only theoretically may have an even heat distribution. For obvious reasons, all the oil flow has to be filtered, not only the lube oil.

Variable frequency systems, which have been frequently discussed in recent times, are still in relatively early development, at least for larger horsepower and speeds. Their basic characteristics are a very simple-looking motor configuration, but rather large quantities of highly sensitive and not very maintenance-free electronics. These electronics need separate, protected and well-ventilated locations, with a filtered air supply.

The torque of such drives is not always as smooth as generally required by connection couplings, gears and other mechanical components. These drives can cause tendencies to create harmonics, and can induce high torque peaks after falling out of synchronous running, as in the case of a short blackout which does not trip the unit. To service such units, personnel with higher qualifications and longer training are necessary. Until now, such drives did not give the high availability figures indicated earlier for fluid couplings.

Variable frequency systems are a very interesting alternative, and will probably get a larger share of the variable speed

applications in the future, depending on the specific use and the location of the drive. Prospective engineers should not, however, only compare efficiency numbers without also taking into consideration the initial cost and the reliability side.

CONCLUSION

Variable speed geared hydrodynamic fluid couplings, a proven means of speed variation, and with years of perfect case histories in thousands of applications with centrifugal machines, have been successfully used to control the flow of centrifugal compressors. The reasons for this success are simple function and robust design, low maintenance needs, high reliability and availability at a very competitive system cost.

BIBLIOGRAPHY

- Estner, S. R., "Hydrodynamic Variable Speed Couplings in the Petrochemical Industry," Voith-reprint 541e, Voith Turbo GmbH & Co. KG, Crailsheim, West Germany (1981).
- Fechner, G., "Hydrodynamic Variable Speed Couplings - Technical Position, Typical Duties," CR-536e, Voith print, Voith Turbo GmbH & Co. KG, Crailsheim, West Germany.
- Fechner, G. and Lang, V., "Wear and Operating Cost Reduction of Slurry Pumps by Means of Hydrodynamic Variable Speed Couplings," ASME Winter Annual Meeting, ASME 80-WA/MH-3 (November 1980).
- Gruschka, B., "Voith Variable Speed Couplings as Regulating Equipment in Power Stations," *Technische Mitteilungen*, 7th Ed., Voith-Reprint CR-510e, Voith Turbo GmbH & Co. KG, Crailsheim, West Germany (1961).
- Keller, R., "The Startup of Hydrodynamic Couplings," CR-512e, Voith-reprint out of VDI-report No. 73, Voith Turbo GmbH & Co., KG, Heidenheim, West Germany (1963).
- Lang, V. and Rees, D., "Economic Advantages of Using Variable Speed Fluid Couplings in Pump Drives," 7th Technical Conference of the British Pump Manufacturers' Association, Voith-reprint, CR-542e, Voith Turbo GmbH & Co. KG, Crailsheim, West Germany (1981).
- Rappold, W., "Installation of Variable Speed Geared Couplings as Centrifugal Compressor Drives," Berlin, West Germany (December 1983).
- Wiegmann, W., "Variable Frequency Drives Versus Hydrodynamic Couplings in Boiler Feed Pump Applications," Voith Transmissions, Allendale, New Jersey (November 1982).

