

VE-2 PLUS 2

VERTICAL EDGER

OPERATION AND MAINTENANCE

MANUAL

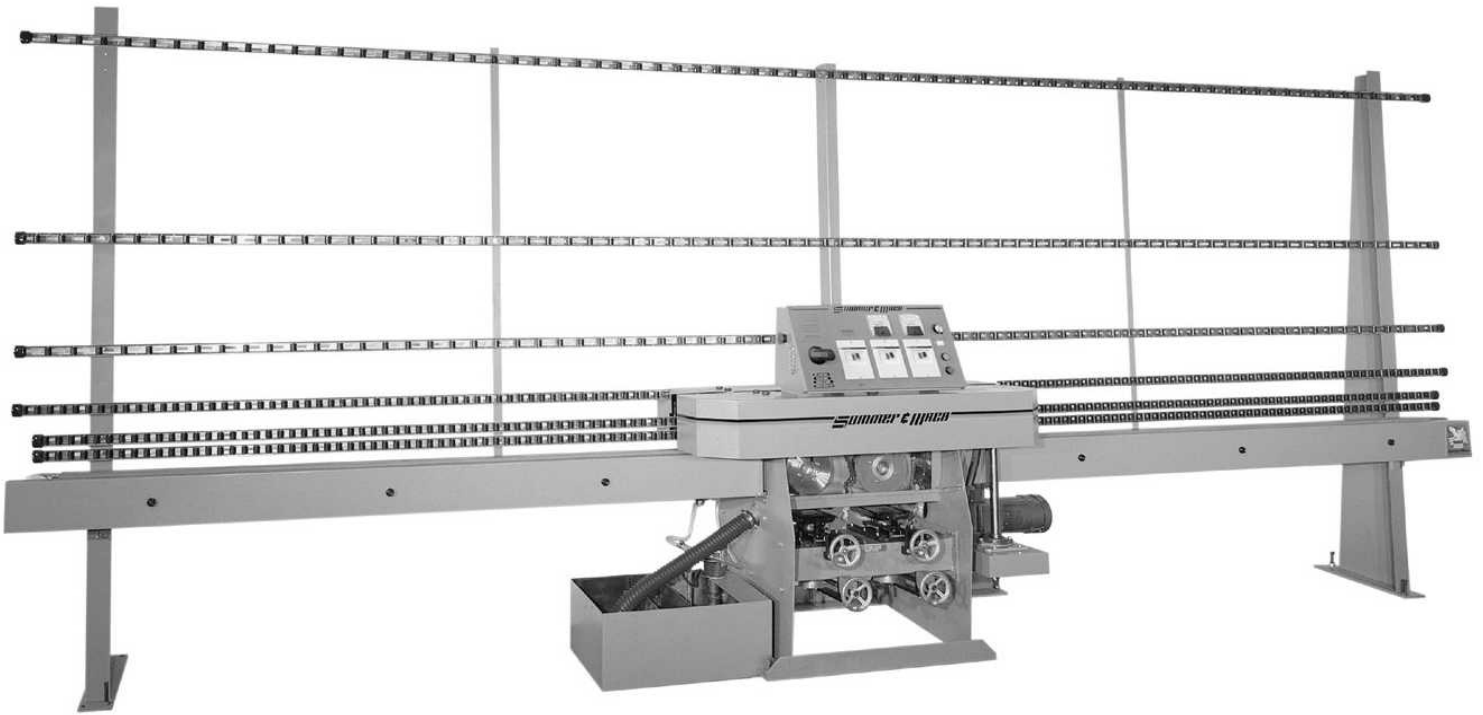

Sommer & Maca Industries, Inc.
5501 West Ogden Avenue
Cicero, Illinois 60804
Tel: (708). 863.5446 / (773). 242.2871
Fax: (708). 863.5462
REVISED 2/6/03

ATLANTA / CHICAGO / DALLAS / MOONACHIE / LOS ANGELES / SANTA CLARA

TABLE OF CONTENTS

SECTION	PAGE
1 - SAFETY	
GENERAL SAFETY INFORMATION	1
Introduction	1
Safe Operating Considerations	1
Care Exercised During Installation	1
Quality and Frequency of Inspection and Maintenance	1
Common Sense Approach to Operation	1
NOTES, CAUTIONS and WARNINGS	1
Notes	1
Cautions	1
Warnings	1
GENERAL PRECAUTIONS	2
Special Warning: Interlocks, safety devices, guards and covers	2
2 – DESCRIPTION	
GENERAL DESCRIPTION	3
CENTER SECTION	3
Control Panel	3
Grind and Polishing Spindles	4
Coolant Pump and Sediment Tank System	5
Conveyor Drive Motor, Gearbox and Gears	5
Conveyor Chains	5
ENTRY AND EXIT CONVEYOR SYSTEM	6
GLASS SUPPORT FRAME	6
SPECIFICATIONS	7
3 – RECEIVING	8
UNCRATING	8
Inspecting Crate	8
Removing Crate	8
Parts List	9
NOTIFICATION	9

SECTION	PAGE
4 – INSTALLATION	
FACILITIES REQUIREMENTS	10
Floor Space	10
Plumbing	10
Compressed Air	10
Electrical Requirements	10
ASSEMBLY INSTRUCTIONS	10
Center Section	10
Conveyor System	11
TEST OPERATION	13
Coolant Pump	13
Adjustment of Grinding and Polishing Wheels	14
Centering of the Wheels	14
Pivoting of the Wheels	14
Vertical Adjustment	15
Conveyor	17
5 – OPERATING INSTRUCTIONS	
GRINDING SPEED	19
OPERATION	19
Adjustments	19
Starting Up the Edger	20
6 – MAINTENANCE INSTRUCTIONS	
MAINTENANCE CONCEPT	21
BASIC CHASSIS AND FRAME	21
Control Panel	21
Spindle Motors	22
ENTRY AND EXIT CONVEYORS	23
Every 40 Hours of Operation	23
Every 80 Hours of Operation or Less	24
FRONT AND REAR CHAIN ASSEMBLIES	24
Tightening Front and Rear Chain Assemblies	24
Assembly Pad Replacement	24

SECTION	PAGE
6 – MAINTENANCE INSTRUCTIONS (continued)	16
FRONT AND REAR CHAIN ASSEMBLY LUBRICATION	25
Every 40 Hour of Operation	25
COOLANT SYSTEM	26
Every 8 Hours of Operation	26
Coolant Line Positioning	26
DRESSING GRINDING WHEELS	27
Diamond Grinding Wheel	27
Polishing Wheel	28
8 – TROUBLESHOOTING PROCEDURES	
PROBLEMS AND SOLUTIONS	29
WARRANTY STATEMENT	30

SECTION 1

SAFETY

FAILURE TO OBSERVE THE WARNINGS, CAUTIONS AND INSTRUCTIONS LISTED IN THIS MANUAL AND ON THE DECALS ATTACHED TO THE VE-2 PLUS 2 VERTICAL EDGER COULD CAUSE SERIOUS INJURY TO PERSONNEL OR DAMAGE TO EQUIPMENT.

GENERAL SAFETY INFORMATION

Introduction

This manual contains installation instructions and operating and maintenance procedures for the VE-2 Plus 2 Vertical Edger. The edger must always be operated and maintained in accordance with the instructions and procedures contained in this manual and on the decals attached to the edger. Only qualified personnel thoroughly familiar with the operating and maintenance instructions should operate and maintain this equipment.

Safe Operating Considerations

Safety must be observed through all facets of operation and maintenance. Proper tools and operating procedures must always be used to prevent accidents that could cause injury to personnel or damage to equipment. Safe, reliable operation and long service are dependent on three important considerations:

1. *Care exercised during installation*

The most important single factor of the edger installation is the alignment and levelling of its three discrete sections and the glass support frames. These must be installed properly on a solid floor so critical alignments will be maintained.

2. *Quality and frequency of inspection and maintenance*

The environment of glass grinds and abrasives requires conscientious maintenance. Frequent inspection and recommended lubrication procedures must be performed to ensure safe and trouble-free operation and machine longevity.

3. *Common sense approach to operation*

The Edger is not necessarily a complex machine due to its functionality and the flexibility it offers; however, there is no witchcraft involved in its operation. Patience and time spent in acquiring familiarity with the aspects of operation will

reveal most of its secrets. The most important rule is:

DON'T TAKE CHANCES!

NOTES, CAUTIONS AND WARNINGS

1. *Notes*

NOTE

The notes contained throughout this manual provide additional information to carry out the operating and maintenance procedures. Any particular note is listed just prior to the procedural step to which it applies. This is an example of a NOTE format.

2. *Cautions*

CAUTION!

The cautions in this manual contain instructions and information concerning operation and maintenance procedures that, if not followed, could cause damage to equipment, parts and facilities. Like notes, cautions are listed just prior to the steps to which they apply. This is an example of a CAUTION format.

3. *Warnings*

WARNING!

The warnings in this manual contain instructions and information concerning operation and maintenance procedures that, if not followed, could cause injury to personnel. Warnings also are listed just prior to the steps to which they apply. This is an example of a WARNING format.

SECTION 1

GENERAL PRECAUTIONS

The precautions listed here are general in nature; however, failure to observe and follow them could result in personal injury or damage to property. These general precautions are not all-inclusive. Specific cautions and warnings are listed throughout this manual and others may occur to the user that are peculiar to a specific operation or industry. In addition, employers are subject to the federal Occupational Safety and Health Act (OSHA) of 1970, as amended, that requires an employer to keep abreast of the regulations that are continually released under its authority.

WARNING!

1. **ALWAYS** operate and maintain the edger in accordance with the instructions and procedures of this manual.
2. **ALWAYS** load glass onto the entry conveyor and allow the belt to drive the glass into the machine. **DO NOT** feed glass directly into the conveyor pads by hand. **DO NOT** wear loose fitting clothing that could get caught in the moving parts of the machine. **DO NOT** exceed the capacity of the edger.
3. **DO NOT** open inspection doors, covers or guards while the unit is in operation except in special circumstances that are addressed later in this manual. **NEVER** work on the edger or related components unless the electrical power and motor drive have been locked out and tagged. The National Electrical Code requires a manually operated disconnect switch located within sight of the machine or other means by which the conductors of the circuit can be disconnected from their source of supply (Parts F and I of Article 230).
4. **DO NOT** use the edger for any purpose for which it was not designed. It is to be used only to edge clean float or plate glass and mirrors. Tempered, reinforced, dirty or painted glass should not be run in the edger. All tags, stickers or tape should be removed prior to edging.
5. **DO NOT** poke or prod into the openings of the edger with a rod, bar or stick.
6. **ALWAYS** have a clear view of the loading and unloading points and all safety devices of the edger. Be aware of all the locations of the emergency stop switches.
7. **KEEP** the area around the edger free of debris and obstacles. This includes the electrical control panel, coolant tank, and entry and exit conveyors.
8. **NEVER** operate the edger without guards and all safety devices in position and functioning.
9. **ALWAYS** allow the edger to come to a stop naturally by ramping down. **DO NOT** attempt to artificially brake or slow the movement of the edger or any of its components.
10. **ALWAYS** wear safety glasses, proper clothes and other necessary safety equipment while operating and maintaining the edger. When in doubt, consult with the shop safety representative(s).
11. **ALWAYS** wear safety glasses, proper clothes and other necessary safety equipment while handling glass. When in doubt, consult with the shop safety representative(s).

WARNING!

Many of the photographs used to illustrate this manual were taken of partially assembled machines or of machines with guards removed for clarity. This should not be construed as a safe method of operation when running this machine. **NEVER** operate the edger unless all interlocks, safety devices and guards are operating properly and properly installed. Failure to do so could result in injury or death.

SECTION 2

DESCRIPTION

GENERAL DESCRIPTION

The VE-2 Plus 2 Vertical Edger (herein called the edger) is designed to fill the need for a compact production machine to grind and polish edges on the most common range of glass thicknesses and sizes. The edger is ruggedly constructed, easy to operate and maintain, and will produce quality edges.

The edger consists of three main assemblies; the center section, the conveyor system, and the glass support frame (see Figure 1). There is an additional recirculating and filtering coolant system.

CENTER SECTION

The center section contains the control panel, the grinding and polishing spindles, drive motors, adjustments and position indicators, conveyor drive motor and gears, coolant pump and filtration system, front conveyor chain drive and the rear register pad conveyor chain drive (see Figure 2).

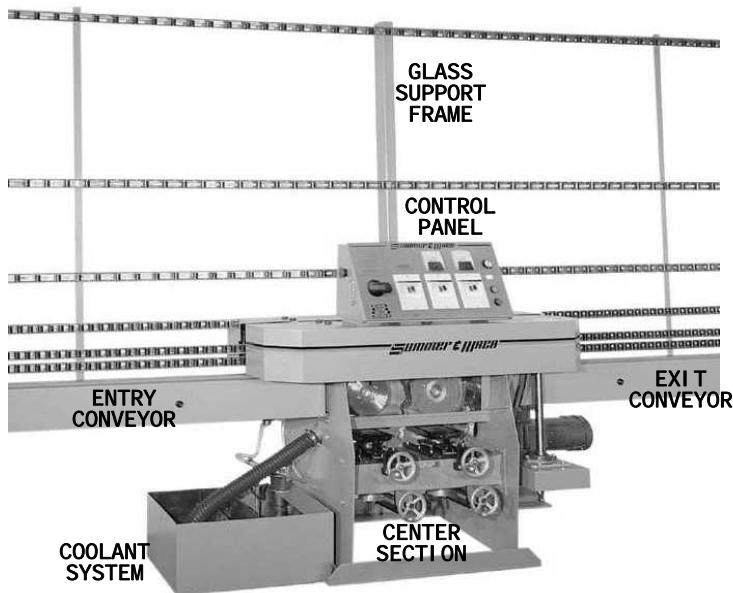

Figure 1

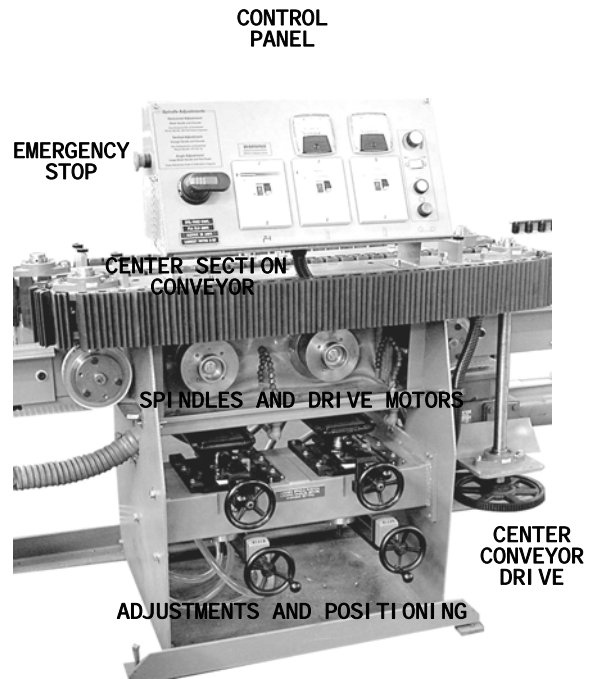

Figure 2

Electrical Control Panel

WARNING!

Voltages dangerous to life are present in the electrical control panel. When the main power ON/OFF switch is in the OFF position, primary power is still present at the top of the input side of the switch near the main fuses. The proper way to disconnect the primary power from the cabinet is to terminate the power at the plant source. The installation of the edger must have a main power safety disconnect switch installed at this plant power source.

The electrical control panel contains all of the control circuitry necessary for the control of the various edger functions. Mounted on the outside of the front panel is the main power ON/OFF switch and the power indicator. Opening the door requires the main power switch to be placed in the OFF position.

SECTION 2

Besides the power disconnect switch, located on the front panel are load indicating ammeters for each spindle, on/off switches for each spindle, stop and start pushbuttons for the conveyor drive, a forward and reverse switch for the conveyor, a speed adjust dial for the conveyor, and an optional running time meter (see Figure 3). Emergency stop switches are located on either side of the front panel.

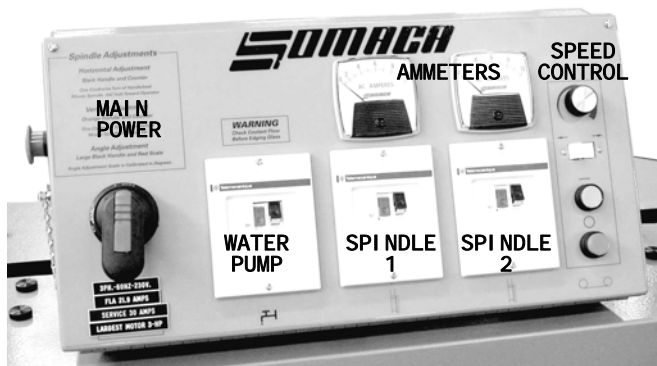

Figure 3

Fuses, a relay, adjustable potentiometers, and a speed controller for the conveyor are located inside the control panel enclosure (see Figure 4).



Figure 4

Grind and Polishing Spindles

The edge of the glass is first ground with the 7" edge/grinding spindle followed by the 8" edge/polishing spindle (see Figure 5). The spindles are adjustable; IN/OUT and UP/DOWN for various thicknesses of glass. They are also pivoted to allow the use of wider profile wheels on a thinner piece of glass. Different wheel profiles can be used for any desired finished edge.

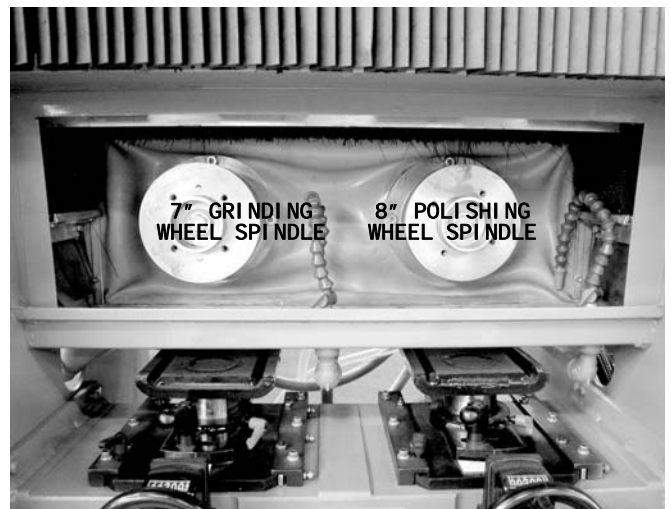

Figure 5

The wheels are driven by special motors. The grinding spindle has a precision spindle assembly. Both spindles have an indicator for vertical adjustment, in/out spindle position, and angular position calibrated by a scale on the compound. Precision digital indicators are utilized for both the height and the in/out positioning. The locking handles are color coded with orange for the vertical adjustment and black for the in/out positioning.

The wheels will grind and polish edges of glass from a minimum thickness of single strength, .090" (2mm) to a maximum thickness of 1/2" (13mm). The wheels can be profiled to provide a pencil or flat-seamed edge (see Figure 6), or any special edge desired.

SECTION 2

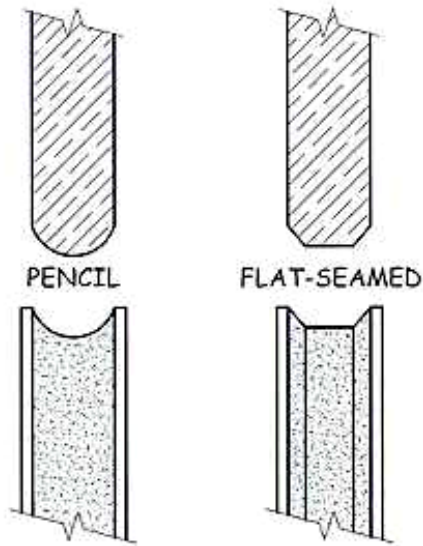

Figure 6

While in operation, the wheels are cooled with a special diamond wheel coolant (Somaca #265-1010) that is recirculated by a coolant pump located in the sediment tank (see Figure 7).

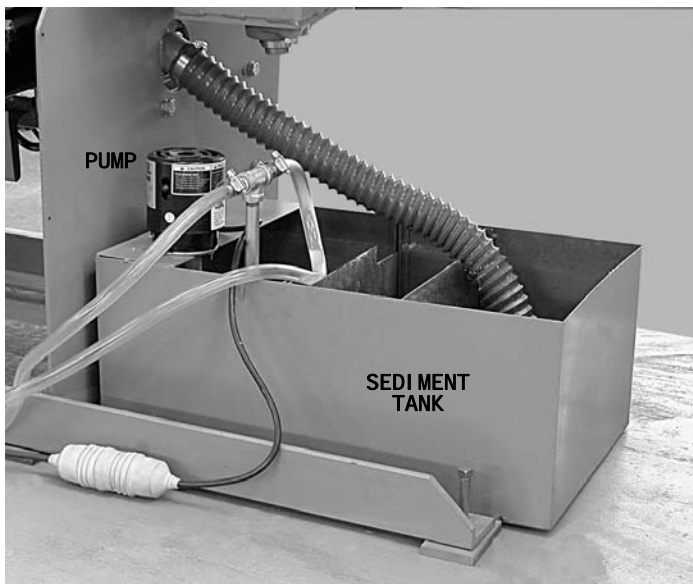

Figure 7

Coolant Pump and Sediment Tank

The purpose of the coolant pump and sediment tank system is to supply a constant flow of diamond wheel coolant that is free of large glass grinds to the grinding and polishing wheels while the edger is in operation. As the immersion pump supplies coolant to the wheels, the spent coolant returns to the tank where most of the glass residue settles out through a weir system before returning to the pump intake.



Figure 8

Conveyor Chains

The main conveyor is driven by chains that are centrally located. The center section conveyor chains (see Figure 8) grip the glass and hold it securely in position during the grinding and polishing operations. The rear chain has register pads attached that grip and release the glass without cracking. The front resilient pads hold the glass and the rear pads in a perfectly straight path through the diamond and polishing wheels.

The chains and guide rails are the heart of the machine. To maintain an accurate edge and trouble free performance, it is imperative the the maintenance schedule in this manual be adhered to with diligence.

SECTION 2

Entry and Exit Conveyor System

The conveyor system transports glass (supported by the vertical glass support frame) on twin cog belts that are powered by the main conveyor drive (see Figure 9) and convey the glass in and out of the center section conveyor. The glass then travels onto the outfeed conveyor belt and exits the center section. The conveyor can be varied in speed from 0 to 100 inches per minute. Both ends of the conveyor are 84 inches long to facilitate loading and unloading glass.



Figure 9

Glass Support Frame

The glass support frame (Figure 10) supports the glass as it is conveyed through the grinding and polishing operations. The two end uprights support both the frame and the ends of the conveyor system. The center upright along with the end uprights have five rows of roller rails. The frame can accommodate glass as small as 3½ inches long and up to 100 inches long by 100 inches high by ¼ inch thick. The maximum weight allowed on glass up to ½ inch thick is 250 pounds. The table opposite demonstrates glass capacities.

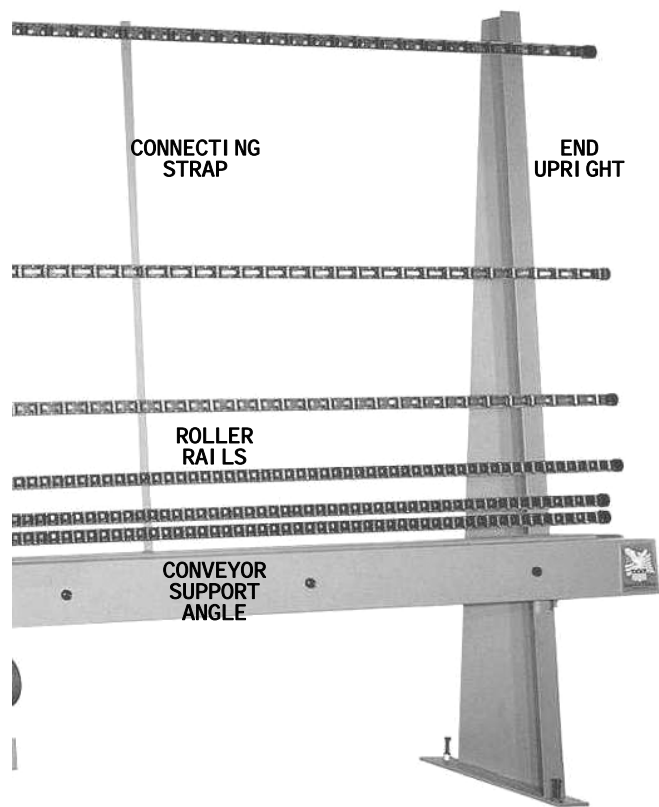

Figure 10

WIDTH (inches)	24	36	48	72	100
THICKNESS	MAXIMUM LENGTH				
1/8	100	100	100	100	100
3/16	100	100	100	100	100
1/4	100	100	100	100	100
3/8	100	100	100	100	69
1/2	100	100	100	75	55

SECTION 2

SPECIFICATIONS

Glass Capacity

- Thickness*Single Strength .090 inch to ½ inch
- Length*3 ½ to 100 inches
- Height* 100 inches maximum
- Weight*250 pounds maximum
- Conveyor Speed*Variable speed from 0 to 100 inches per minute

Wheel Stations

- Grinding*3 Hp, 3450 rpm arbor motor with a 7 inch diamond grinding wheel
- Polishing* 2 Hp, 1750 rpm motor with an 8 inch polishing wheel

Both wheels have height adjustments for wheel depth, angularity for glass thickness, in/out for wheel centering on glass, with the ability to be profiled for pencil, flat-seamed or any other edge configuration commonly done on a peripheral wheel edger.

- Spindle Load** Ammeters indicate the load on each spindle
- Electrical** 3 phase, 60 Hz, 230 volt, 25 amp, 4-wire (grounded)
OR
1 phase, 60 Hz, 208-230 volt, 25 amp, 3-wire (grounded)
- Plumbing**No direct hookup required
- Weight**Approximately 2,000 pounds (910 kg)

SECTION 3

RECEIVING

UNCRATING

Every VE 2+2 Vertical Edger is tested and adjusted to work perfectly before shipment. Every component is tested in actual glass cutting conditions to guarantee proper operation before shipment. It is essential that the edger is received and handled properly before installation to ensure that it was received in exactly the same condition as it was when it left the factory and that it reaches the site where it will be set up for operation without damage.

The edger is shipped on one large skid (see Figure 11). The center section is attached to the wood and loose items are packed inside of the coolant reservoir. The machine has the exit and entry conveyors detached from the main body to facilitate shipping. All other components and assemblies are secured within the crate.

WARNING!

The crate with the VE 2+2 Vertical Edger weighs approximately 2,000 lbs. The center section alone weighs 1,600 lbs. Use adequate lifting devices to move the crate and machine components.

Inspecting the Crates

Crate damage could indicate that the shipment has been mishandled and that the machine could be damaged. It is very important that the machine be inspected for exterior damage immediately upon receipt. Use the following procedure for inspection:

1. Check all surfaces of the crate for gouges, tears or holes that could have been made by the forks of a forklift or some other lifting device.
2. Check for crushed corners, edges or framing members that could indicate that the crate was dropped.
3. Check for broken crate straps and breaks or distortion in the framing of the crate.

4. Inspect the plastic wrappings that cover the components and assemblies. Carefully note any damage to the wrappings.
5. Remove the framing and plastic wrappings as necessary to inspect the machine, especially in the areas of obvious visible damage.

Notification

Document any and all damage to any part of the beveller or its ancillary equipment. Notify the carrier and Sommer and Maca Industries, Inc. immediately upon detection of any damage.

Removing the Crate

3. Cut the straps and remove the crate from the center section. Note that the frame of the center section is bolted to the wooden skid. Remove the bolts and discard.
4. Check the entire center section for damage, especially in the area of any crate damage noticed in the inspection procedure described previously.

NOTE

At the time the the edger was disassembled for shipment from the factory, all of the hardware including screws, nuts, washers, etc., to construct the machine were placed in bags and located inside of the coolant reservoir.

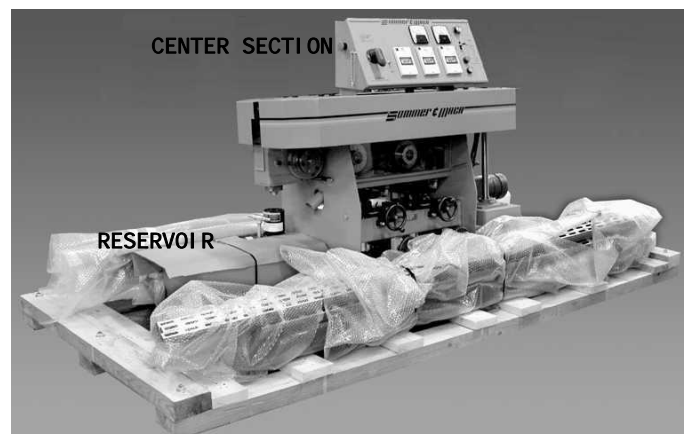

Figure 11

SECTION 3

5. Remove the coolant pump and reservoir, the conveyor system and the glass support rack. Unpack all of the parts and inspect each for damage.
6. Use a proper lifting device and lift slings to raise the machine off of the mounting skid. It is recommended that the machine be in the desired location, if possible, so that handling of the machine is kept to a minimum.

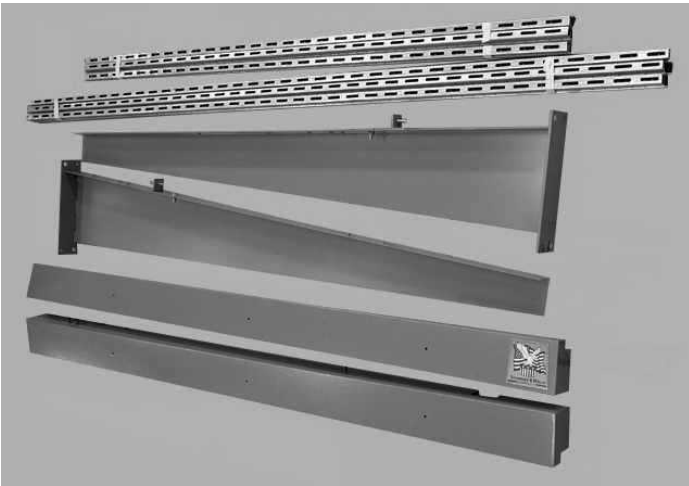

Figure 12

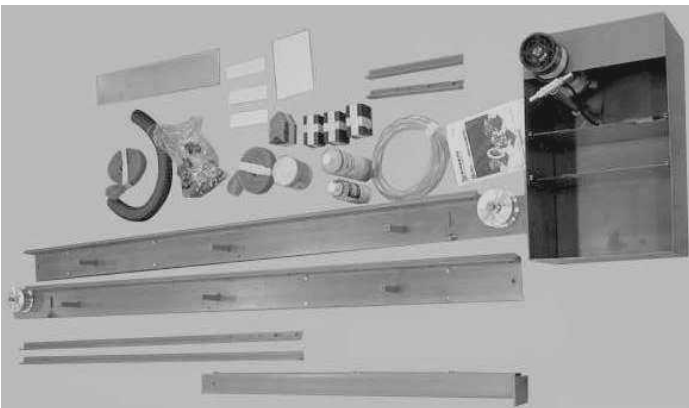

Figure 13

Parts list

The items in the shipment should consist of (see Figure 12, Figure 13):

- a.) Left and right guards, left and right connecting straps, rail support rack, six long roller mounting rails, and six short roller mounting rails.
- b.) Left and right support racks and conveyor system support angles.
- c.) Left and right conveyor belts.
- d.) Loose hardware consisting of:
 - (36) 1/4-20 x 1/2 hex head cap screws
 - (36) 1/4 split lock washers
 - (6) 1/4-20 x 1 thumb screws
 - (12) 3/8-16 x 7/8 hex head cap screw
 - (12) 3/8 split lock washers
 - (2) 1/2-13 x 1 1/4 hex head cap screws
 - (2) 1/2 split lock washers
 - (4) 1/2 flat washers
 - (2) 1/2 x 3/8 shoulder bolts (3/8-16)
 - (4) 1/4-20 x 1 stainless socket head cap screws
 - (8) 1/4-20 x 1 1/4 stainless socket head cap screws
 - (16) 1/4 stainless steel flat washers
 - (10) 1/2-13 x 2 3/4 square head set screws
 - (10) 1/2-13 hex jam nuts
 - (1) 2" diameter Flexhaust Gray x 36"
 - (2) 1 1/16 to 1 1/4 hose clamps
 - (1) 1 9/16 to 2 1/2 hose clamp
- e.) Loose components consisting of (see Figure 12, Figure 13):
 - (1) bag of hardware for components (see "d." above)
 - (1) 16 ounce can of Teflon grease
 - (1) quart diamond wheel coolant
 - (3) wheel dressing stones
 - (12) foot pads
 - (8) mounting angles
 - (1) 1/4" dressing board
 - (1) 3/16 T-handle Allen wrench

Notification

Document any and all damage to any part of the edger or its ancillary equipment. Notify the carrier and Sommer and Maca Industries, Inc. immediately upon detection of any damage.

SECTION 4

INSTALLATION

FACILITIES REQUIREMENTS

Floor Space

The edger is 18 feet 8 inches long and 3 feet 5 inches deep (from the front to the back of the main body) and 7 feet 5 inches high. The floor space required for operation of the machine is 20 feet in length. About 3 feet of clearance behind the machine should be allowed to permit access of the coolant tank, cleaning and maintenance. The floor area must be clean and free from grease, oil and water. When installing the machine, consideration should be given to the size of glass to be used to ensure proper clearance of the sides of the machine when loading and unloading the workpiece.

WARNING!

The edger is shipped with all components and ancillary equipment in a single crate weighting approximately 2,000 pounds. The edger center section (main body) is the heaviest unit and is top heavy. When it is lifted, prevent it from tipping and damaging the unit or endangering personnel.

Plumbing

Although the edger requires no direct hookup, a water supply and drain should be easily accessible for filling, cleaning and draining the coolant tank of sediment. Ideally, a floor drain in close proximity to the machine will facilitate cleaning and run-off.

Electrical Requirements

WARNING!

Ensure that all electrical connections and service lines do not contact water.

A 3-phase, 60 Hz, 208-230 volt, 25 amp power source (or 1 phase, 60 Hz, 230 volt, 40 amp) is required.

The power source must also have a safety disconnect switch for servicing the edger. Local electrical codes may require this switch. All wiring must meet local electrical codes.

WARNING!

The EMERGENCY STOP slap switches DO NOT disconnect power from all components of the machine.

ASSEMBLY INSTRUCTIONS

Center Section

1. Unpack the machine (refer to Section 3).
2. Place the machine in the designated location where the machine will be operating. Position the entry conveyor next to and on the left side of the edger center section. Position the exit conveyor next to and on the right side of the conveyor center section.
3. Install the supplied steel pads directly beneath the legs of the edger, infeed and exit conveyors.

NOTE

The steel pads provide a recess for the machine levelling screws. The pads may be grouted or anchored to the floor to prevent creep and possible loss of critical alignment and levelling adjustments made during installation. The steel pads must not be grouted or anchored to the floor at this time. Anchoring or grouting will be accomplished after levelling has been done.

4. Using the levelling screws, level the center section from side to side. Next, level the center section front to back. A 5° tilt toward the back of the machine will be noticeable at the glass line when this procedure is done correctly. Use a quality level for this procedure (see Figure 14).

SECTION 4

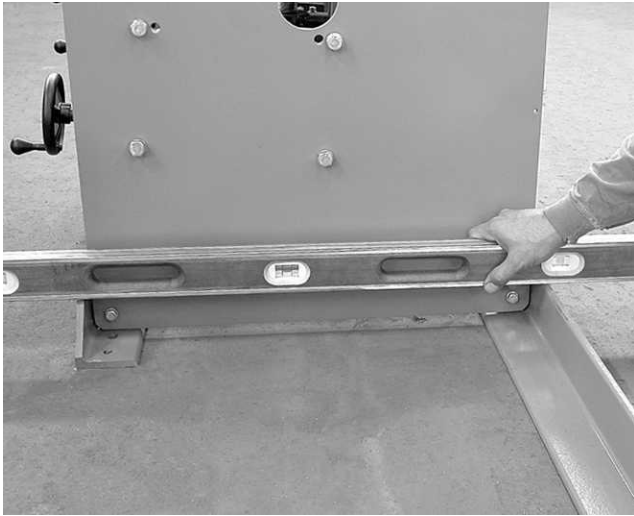

Figure 14

5. Position recirculating pump and connect the coolant hose, power cord and coolant return drain hose as shown in Figure 15.

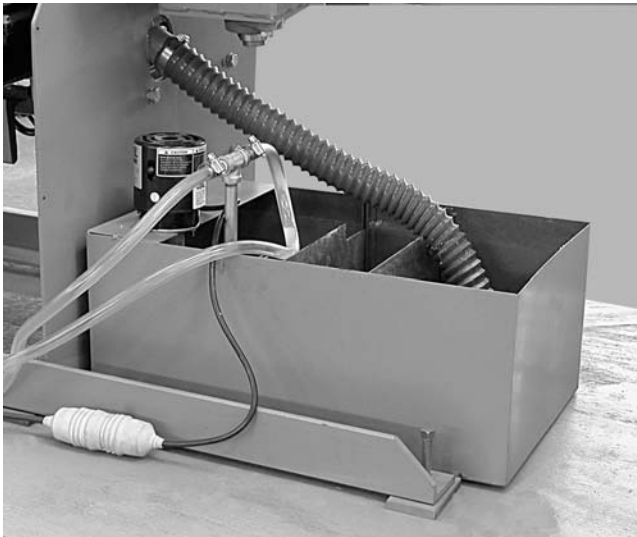

Figure 15

6. Mix 1 part of SOMACA diamond wheel coolant (SM304DW) to 100 parts water or as recommended and fill the pump reservoir to 1-2 inches from the top of the tank. That is approximately 14 gallons.

NOTE

Sometimes the coolant/water mixture may foam excessively requiring an anti-foaming agent. Sommer & Maca carries this product in stock (SOMACA #265-1802).

7. Connect the power source to the control panel. Make sure that the connection is in compliance with local electrical codes.

Conveyor System

NOTE

The attaching points for the conveyor system support angles to the center section uses a shoulder bolt as provided, ensuring matching tilt with the center section and to aid in levelling.

1. Install the conveyor system support angles to the center section with the shoulder screw provided (see Figure 16). Support the opposing ends with a stand approximately 30 inches high. Install the shoulder screw finger tight at this time.

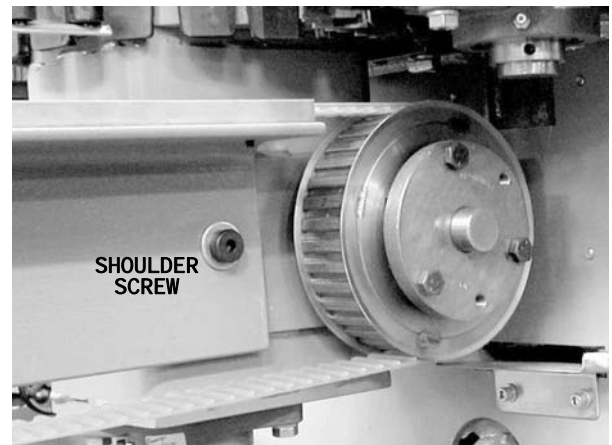

Figure 16

SECTION 4

2. Install the conveyor system support angles to the end support racks (see Figure 17). Install the flat washer, lockwasher and $\frac{1}{2}$ -13 x $1\frac{1}{4}$ " long hex head screws finger tight at this time.



Figure 17

3. Adjust the levelling screws in the support racks to tilt the support racks 5° towards the back, matching the center section (see Figure 18). Check for alignment down the path of the glass when performing this procedure.



Figure 18

4. Install the conveyor belts (see Figure 19) and tighten to achieve a $1\frac{1}{2}$ to 2 inch deflection when pressing lightly on the lower part of the belt 12 inches from the pulley. Tighten the holddown screws after adjusting for proper belt tension.

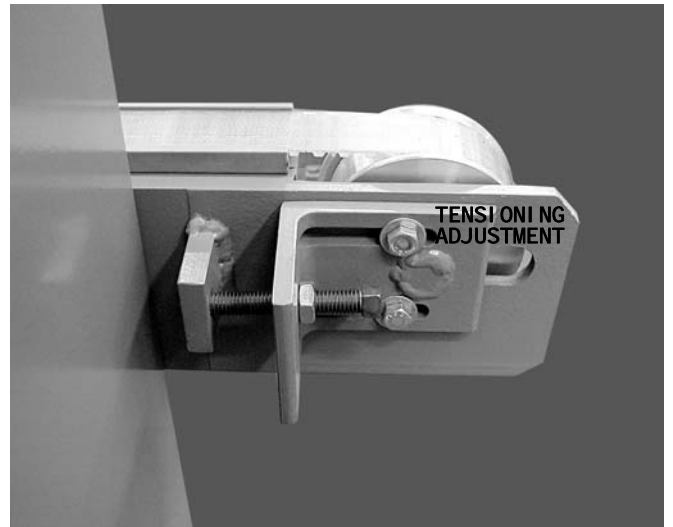

Figure 19

5. Install the rail support onto the top of the center section (see Figure 20) and tighten the four hex screws.



Figure 20

Figure 22

SECTION 4

6. Install the left and right vertical connecting straps to the conveyor system support angles (see Figure 21). Do not tighten these bolts at this time.



Figure 21

7. Install the roller mounting rails (see Figure 22) starting with the lowest rail first.

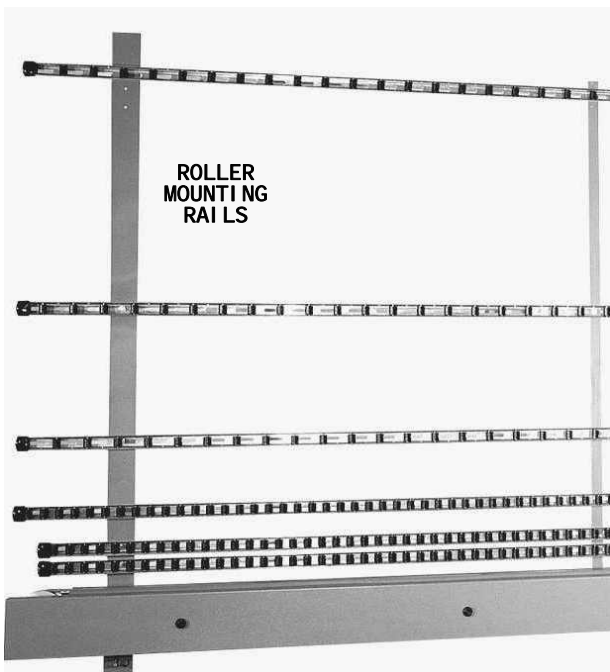

8. Level the loading conveyor, 0° side to side, with a precision level (see Figure 23). Repeat this procedure with the unloading conveyor. After this is done, tighten all of the screws in the previous steps.

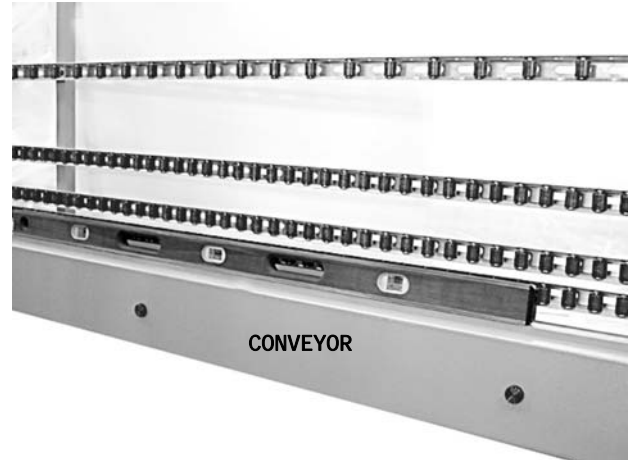

Figure 23

9. Install the guards. Fasten with the thumb screws provided.

TEST OPERATION

Coolant Pump

Turn the coolant pump switch “ON” (see Figure 24).



Figure 24

SECTION 4

Observe that coolant is flowing to both the grinding and polishing wheels. Adjust the lines to spray onto the top of the wheel where it contacts the glass.

Grinding and Polishing Wheel Adjustment

Three adjustments must be made on the grinding and polishing wheels before any glass is run through the machine. The first adjustment is for centering the wheels on the glass. The next adjustment is for the vertical height which controls the amount of glass being removed.

WARNING!

Do not adjust the wheels while the spindles are running. Make sure that the spindles are off. Failure to do so may result in machine damage and risk of injury.

WARNING!

Never install a polishing wheel on a grind wheel spindle. Most polishing wheels are not constructed to withstand a 3450 rpm spindle speed and may explode if installed incorrectly. Wheels must be installed with the screws provided.

Centering of the Wheels

The initial setup of the wheels is made when the rear pads and the flange of the wheel hubs are in one plane. At that point, the digital indicators should read "0" (zero). Center the grinding wheel on the glass by using the formula as follows:

$$\frac{\text{Grind wheel thickness}}{2} - \frac{\text{glass thickness}}{2}$$

Example 1:

If the grind wheel is $\frac{5}{8}$ " thick and the glass is $\frac{1}{4}$ " thick (.220")

$$\frac{.625}{2} - \frac{.220}{2} = .312 - .110 = .202$$

CAUTION!

DO NOT move the slide with the slide lock engaged. To do so will cause damage to the slide resulting in excessive backlash in the adjusting mechanism.

NOTE

All handwheels have some amount of backlash that is felt when reversing direction. Always make sure to make the last movement, when adjusting, in a clockwise direction. If the adjustment is overshot, back out 2 turns and approach again.

To adjust for this thickness, turn the handwheel counterclockwise which moves the wheel in until the display reads "202" (see Figure 25). (Note: Each revolution of the handle is .040" of horizontal movement.

Example 2:

If the grind wheel is 1" thick and the glass is $\frac{1}{2}$ " thick (.500")

$$\frac{1.000}{2} - \frac{.500}{2} = .500 - .250 = .250$$

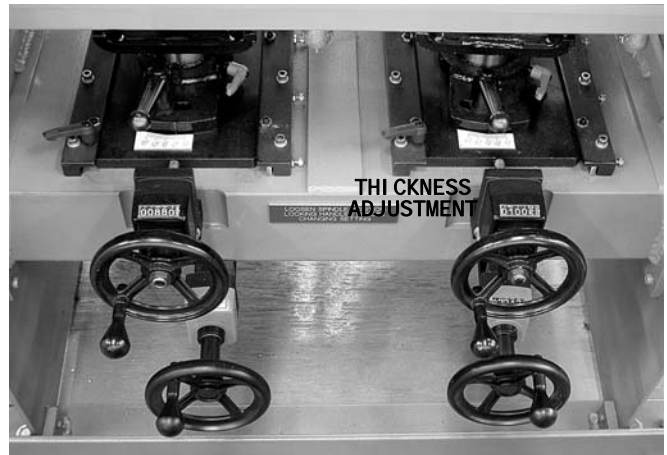

Figure 25

When done, lock the horizontal slide with the locking handle.

Pivoting of the Wheels

The wheels pivot to allow for the use of a wide range of profile wheels on a thinner piece of glass. The range of pivoting is -5° to +15°. An index label

SECTION 4

placed on the back of the spindle angle sleeve indicates the pivoting range. A clamping bolt holds the angle sleeve in position.

When pivoting the wheel, the bolt must be loosened and the scribed line on the sleeve must be lined up with the desired angle on the index table.

NOTE

Due to the specific design of the edger spindle, the position of the wheel should be corrected in relation to the glass. Some wheels, even when pivoted, may not give the desired edge. Caution must be exercised when pivoting grinding wheels since starrng and chipping of the glass may result, especially on mirror backing and coatings. Sommer & Maca offers a variety of wheel profiles in stock. Contact your local representative for more information.

Below is a chart indicating the linear correction that must be applied to the wheel after pivoting (i.e., the wheel must be moved forward).

PIVOT ANGLE	CORRECTION (INCHES)
±1	N/A
±2	.003
±3	.007
±4	.011
±5	.018
±6	.026
±7	.035
±8	.046
±9	.058
±10	.072
±11	.087
±12	.104
±13	.122
±14	.141
±15	.162

If desired, angle the wheel to the glass by loosening the angle adjustment lock handle and rotate the the spindle assembly to the desired angle as read on the angle scale at the base of the spindle. The table below gives some typical angles, but these are

examples and individual preferences and wheel profiles will dictate the end results.

WHEEL PROFILE	1/2	3/8	1/4	3/16	1/8
1/2 F.S.	0°	4°- 8°	8°- 15°	N.R.	N.R.
1/2 P.E.	0°	0°- 5°	5°- 8°	8°- 11°	11°- 15°
3/8 F.S.	N.R.	0°	4°- 8°	6°- 10°	8°- 15°
3/8 P.E.	N.R.	0°	0°- 5°	5°- 8°	8°- 11°
1/4 F.S.	N.R.	N.R.	0°	4°- 8°	6°- 10°
1/4 P.E.	N.R.	N.R.	0°	0°- 5°	5°- 8°

N.R. = NOT RECOMMENDED

F.S. = FLAT SEAMED

P.E. = PENCIL EDGE

Vertical Adjustment

The vertical adjustment is made as follows:

NOTE

The actual travel is 1/2 of what the indicator reads; one revolution with a reading of .020 is actually a change of .010". When feeding the wheel "UP" (turning the handwheel clockwise), the numbers on the indicator will decrease.

1. Start the edger.
2. Run a piece of glass of a thickness suitable for the wheel size slowly through the edger. Stop the conveyor when the glass is above the grinding wheel.

WARNING!

Always wear heavy glass handling gloves when transporting glass. Failure to do so may result in serious cuts or gashes. Always put the glass on the entry conveyor feed belt and allow the conveyor to pull the glass into the front and rear conveyor pads (center section). Keep your hands away from moving conveyor pads. The pads can clamp onto your hand and pull your arm into the machine causing serious injury. Always use extreme caution when loading glass. Never wear loose clothing that can get caught in the pads and pull you into the machine. Always use extreme caution when loading glass. Know where the two emergency stops are located and be prepared to use them in an emergency.

SECTION 4

3. Unlock the vertical adjustment lock handle and raise the grinding wheel by turning the handwheel clockwise. Continue to raise the spindle assembly until the dial indicator reads the diameter of the wheel. This diameter (7.000") is read directly on the indicator. As the indicator approaches the reading desired, visually observe the wheel so that it does not touch the glass, but that it is as close as possible without contact.
4. Back the glass out of the machine. Turn the vertical adjustment up (clockwise) 3 ½ turns or .035" (one rotation is .010") after allowing for backlash. Lock the vertical adjustment.
5. Adjust the conveyor speed to 25 IPM and start the machine. Run the glass in until it about 3 inches is cut by the diamond wheel. Make sure the coolant line is positioned properly. Stop the conveyor and reverse it to back the glass out of the machine.
6. Inspect the partial cut for proper depth minus 1/32" (-.031) and desired profile. Make adjustments accordingly, noting that the dial indicator for the in/out adjustment reads .001" and the vertical adjustment indicator reads in the wheel diameter, not travel (wheel diameter is 2X vertical travel). Also, one full turn of the handle is .010" of travel.
7. Run glass completely through the machine and re-examine to determine if any minor adjustments need to be made.
8. Run a dressing board through the grinding wheel to establish a pattern on the board. This will be used for profiling the polishing wheel.
9. Turn the polishing spindle to a 5° tilt or the same tilt as the grinding spindle, if desired, and run the pattern dressing board in the edger until it is above the polishing wheel. Stop the conveyor and raise the polishing wheel until a slight amperage draw is seen on the ammeter. Restart the conveyor and run the dressing board from left to right over the grinding wheel again. several times to establish the pattern on the polishing wheel.

When it comes in contact with the wheel a second time, raise the wheel to obtain a 2 to 4 amp draw. Do this several times to establish a pattern on the polishing wheel.

10. Tighten all lock handles.
11. Run the test glass completely through the edger so that it is both ground and polished. Make additional adjustments in wheel height and groove centering so that 1/32 (.031) of an inch of glass is removed and that the desired edge (pencil or flat and seam) is attained. Tighten all lockscrews. Inspect for a full polish.

NOTE

The pitch of the polishing wheel should be between 3° to 5° and centered on the glass. This is to ensure that no silver or backing is removed from the back of the mirror by the edging wheel.

12. Run a piece of glass 84 inches in length through the edger lengthwise. The glass should enter and exit straight and not ride up or down during the grinding and polishing process. The motor load of each spindle should remain constant. If it deviates, the far end of the loading conveyor must be adjusted until the amperage draw remains constant.
13. Next, run a piece of glass at least 72 inches long through the edger and listen to the cut. If the sound becomes quieter as the grinding is almost complete, lower the ingoing conveyor ½ turn (on the adjustment screw) and raise the outgoing conveyor ½ turn (adjustment screw).
14. Based on the finished edge produced at this point, it is now a matter of fine tuning. Examples of conditions are described on the next page.

SECTION 4

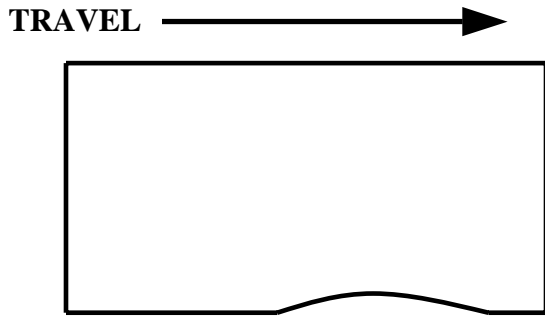

To change this condition, the ingoing conveyor adjustment must be raised 1/2 turn and the outgoing conveyor must be raised 1/2 turn.

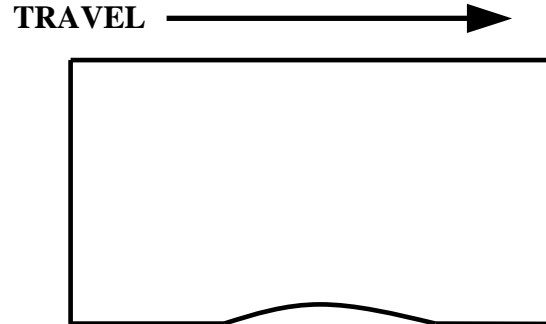

This will move to the left, depending on which conveyor is being adjusted. To eliminate this condition, adjust both conveyors “up” 1/8 turn.

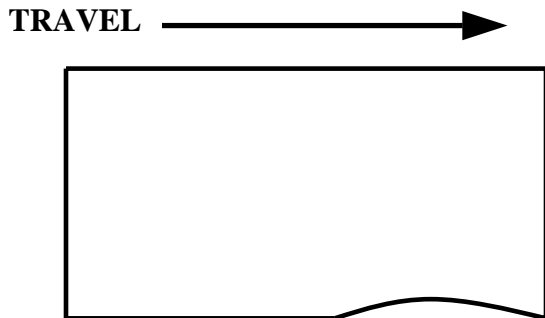

To change this condition, the outgoing conveyor adjustment must be lowered 1/8 turn and the ingoing conveyor must not be adjusted.

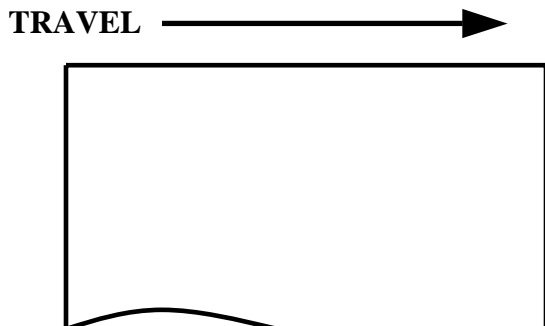

To change this condition, the ingoing conveyor adjustment must be lowered 1/8 turn and the outgoing conveyor must not be adjusted.

15. After steps 10 through 15 have been completed, return to step 3 and reset the depth of cut.

16. Finally, run the conveyor at full speed and view the grinding spindle amp meters. The load of each spindle should remain constant while grinding or polishing.

Conveyor

NOTE

The conveyor will not run unless the grinding spindle, polishing spindle and the coolant pump are “ON”.

1. Turn the conveyor forward/reverse switch to the forward position (see Figure 26).



Figure 26

SECTION 4

2. Set the speed adjust at 50 percent and press the START button (see Figure 27).

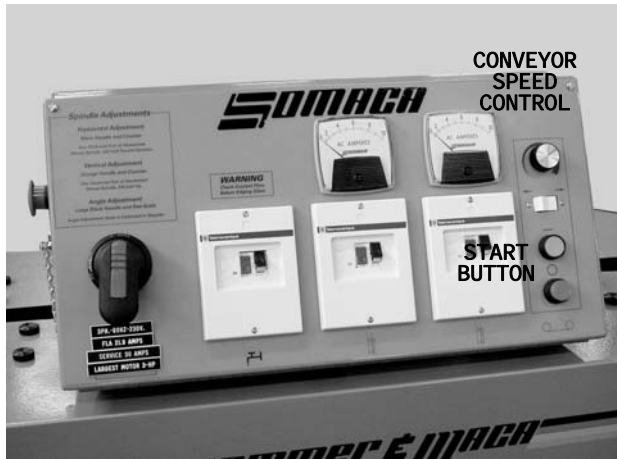

Figure 27

3. Observe that the conveyor belts are moving from left to right when facing the front (operator's side) of the edger. The front conveyor chain (with the "finger" pads) is moving clockwise, and the rear conveyor chain is moving counterclockwise.
4. Alternate the conveyor speed from fast to slow using the conveyor speed control. Confirm the change in conveyor speed as the adjustment varies.
5. Place the FORWARD/REVERSE toggle switch in the reverse position. Observe that the belts and conveyor chains are moving in the opposite direction of travel as noted in step 3 above.
6. Repeat step 4 above with the machine running in the travel reversed.
7. Place the FORWARD/REVERSE toggle switch in the forward direction and turn the conveyor and coolant pump "OFF".

OPERATING INSTRUCTIONS

GRINDING SPEED

The speed at which glass is ground and polished (speed of the conveyor) is adjustable from 0 to 100 inches per minute as noted in Section 2, Description. This speed is dependent upon six factors:

- Hardness of glass
- Thickness of glass
- Type of glass (plate, float or sheet)
- Grit and type of the grinding and polishing wheels
- Depth of grind
- Smoothness of the finished edge that is desired

The softness or hardness of the glass, its thickness and the smoothness of the cut edge will determine the grinding speed. For example, plate glass can be worked faster than the same thickness of sheet or float glass, thinner glass can be edged faster than thick glass, and hard glass is slower to edge than softer grades.

Another important factor is the grit of the diamond wheels to the speed of the grinding. The coarser the grit, the faster the wheel will edge. Conversely, coarse grit wheels will leave rough edges with chipping. Fine grit wheels edge slower, but produce a smoother cut and do not remove as much glass. Another factor of a finer wheel is shorter wear life.

The amount of glass to be removed is another important factor of edging speed. To achieve the fastest edging speed and the longest wheel life, the smallest amount of glass possible should be removed. If the cut edges are straight and without flares or protrusions, then the amount of glass to be removed is minimal. If the cut edges are jagged and uneven, then a greater amount of glass will have to be removed. This may require two passes for satisfactory results.

The desired edge for each glass thickness will be determined through experimentation of grinding speed and depth of cut combinations. The result should be recorded so that the conditions can be duplicated at a later date.

Your own experience in your environment with the VE 2+2 Edger will ultimately be the most valuable source of “how to” information on operational parameters. For purposes of startup, tables with recommended settings and speeds for most normal conditions has been provided.

OPERATION

Adjustments

1. Set the grinding and polishing wheels to the proper setting for the thickness of glass to be ground (see **Grinding and Polishing Wheel Adjustment**, Section 4).
2. Adjust the height of the wheels for the desired depth of cut; typically, this is $1/32$ ”.

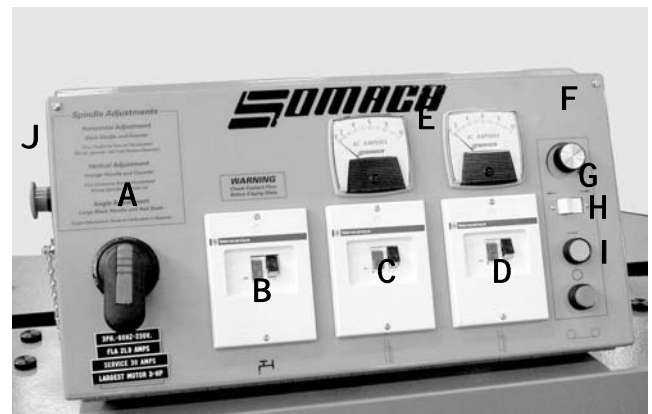

Figure 28

- A – Main Power Switch**
- B – Coolant Pump Switch**
- C – Spindle #1 Switch**
- D – Spindle #2 Switch**
- E – Ammeters**
- F – Conveyor Speed Adjustment**
- G – Conveyor Forward/Reverse**
- H – Conveyor Drive Stop**
- I – Conveyor Drive Start**
- J – Emergency Stop Button**

SECTION 5

Starting Up the Edger

1. Turn the main power switch to “ON” (see Figure 28, “A”).
2. Place the coolant switch in the “ON” (“B”) position. Make sure that the coolant stream is directed onto the wheels at the point of contact with the glass. Adjust the coolant lines if necessary.

CAUTION!

DO NOT run glass through the edger unless coolant is flowing to each wheel at the point where the wheel contacts the glass. If a diamond grinding wheel is run dry, the heat generated may break the glass and damage the wheel.

3. Place the conveyor drive toggle switch (“G”) in the FORWARD position and press the START (“I”) button to start the conveyor. Adjust the speed control (“F”) to the desired speed. Refer to the table below for an initial setting for glass thicknesses. It should be noted that these are only starting points and factors such as glass type and the condition of the initial edge will vary these settings. Finer adjustments may be necessary to achieve the desired depth of grind for each thickness of glass.

GLASS THICKNESS	DEPTH OF CUT		
	1/32	3/64	1/16
1/8 (3mm)	72/100	66/92	60/83
3/16 (5mm)	60/83	54/75	48/66
1/4 (6mm)	48/66	42/58	36/50
3/8 (10mm)	36/50	24/33	24/33
1/2 (12mm)	24/33	24/33	24/33

4. Press the “START” buttons on each spindle switch (“C, D”).

CAUTION!

NEVER exceed the glass capacity of the edger as listed in “SPECIFICATIONS” in Section 2.

CAUTION!

DO NOT start or stop any operations of the edger while the glass is over the grinding or polishing wheels. If an emergency occurs, press either Emergency Stop Button (“J”) located on both sides of the control console.

WARNING!

The Emergency Stop Buttons **DO NOT** disconnect power from all parts of the machine. **DO NOT** use the Emergency Stop Buttons as a substitute for the main power safety disconnect switch or the main power switch. To do so may result in death or serious injury from electrical shock from live wires or terminals.

5. Load the glass onto the entrance conveyor (left side when facing the front of the edger) to begin normal operation.
6. Observe the ammeters (“E”) for each spindle as the glass is passing over the grinding and polishing wheels (see Figure 29). Both meters should read about “4” under normal conditions.



Figure 29

SECTION 6

MAINTENANCE

MAINTENANCE CONCEPT

This section is divided into main headings that provide instructions for various maintenance procedures dealing with electrical, adjustments and minor repairs, lubrication, and grinding and polishing wheels.

BASIC CHASSIS AND FRAME

Control Panel

The electrical control cabinet contains all the electrical circuitry for controlling the edger and is almost maintenance free. However, replacement of the fuses, motor protectors, or other components may be necessary upon occasion.

WARNING!

Disconnect the power to the edger at the main power source safety disconnect switch before performing any maintenance on the electrical control cabinet. Failure to do so may result in serious injury or death.

OSHA 29 CFR 1910.147 standard requires the placement of a lockout on energy stored equipment in a manner that will render them safe to work on and prevent the inadvertent start up of such equipment, in accordance with an established procedure, and ensure that the energy-isolating device and the equipment being controlled cannot be operated, while it is being serviced or maintained, until the lockout device is removed.

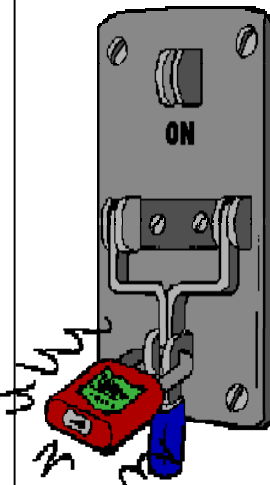

1. Use a fuse puller to replace any of the eight large fuses (see Figure 30).

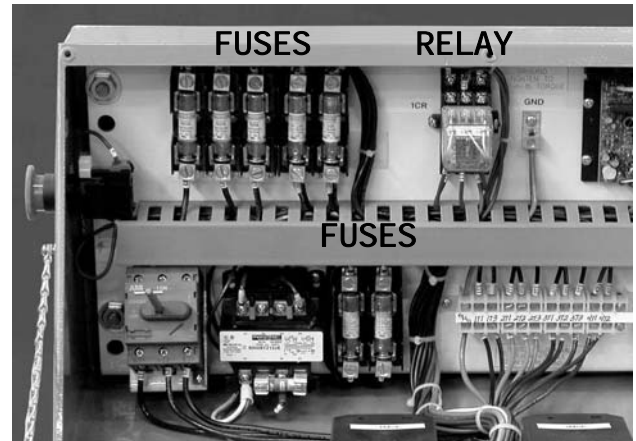

Figure 30

2. To replace any switch, first make a note of where each wire is attached using the wire color and number. Proceed to disconnect each wire and remove the switch. Re-connect the wire to the new switch, matching the numbers to the proper poles on the switch.
3. To replace the relay, simply unplug it from its socket and install a new one (see Figure 31).



Figure 31

SECTION 6

Spindle Motors

The motor that drives the edge grinding wheel is a 3450 RPM motor and the motor that drives the edge polishing wheel is a 1750 RPM motor.

WARNING!

The spindle motors are **NOT** interchangeable. The motor driving the diamond grinding wheel has a 3 Hp rating and runs at a much higher RPM. The polishing spindle motor has a 2 HP motor and runs at about ½ the speed of the grinding motor. **NEVER** install a polishing wheel motor on a grinding spindle or vice versa.

Procedure for replacing a spindle motor

Place the electrical control cabinet main power switch to the “OFF” position.

Remove the cover to the electrical connection box located on the motor being replaced. Tag and disconnect the wiring. Loosen the connector to the box and pull the wiring harness from the box.

1. The grinding and polishing motors have the hub as an integral part of the motor shaft. The removal of the wheel exposes the hub and splash shield. The hub will not come off. The splash shield encompasses the hub and forms a mechanical enclosure for the protection of the motor bearings from water and glass grinds.
2. Remove the bolt securing the wheel to the motor shaft. Open the electrical box on the motor and mark the wires first before disconnecting.
3. From the back side of the machine inside the coolant trough, remove the four nuts that secure the shroud and brush shield to the face of the motor (see Figure 32).
4. Remove the coolant lines if necessary.
5. To remove the hub, use a puller and remove the hub from the motor shaft. Remove the key from the motor shaft if it does not come off with the hub.
6. On the grinding spindle, remove the four screws and lock washers that secure the motor base to the guide base (see Figure 33).

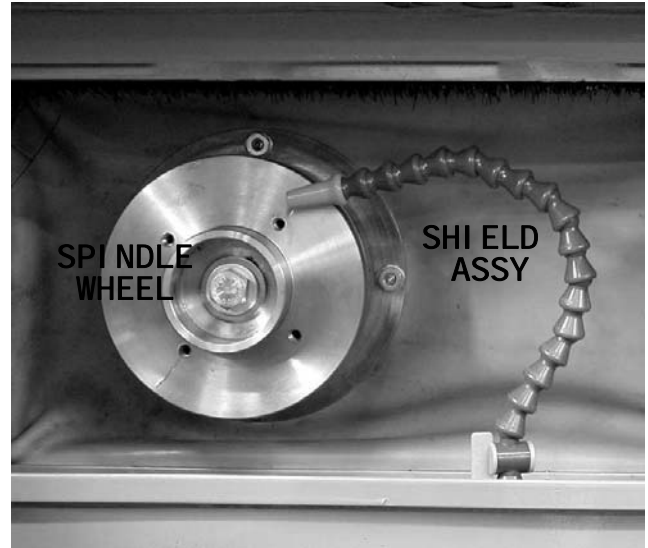

Figure 32



Figure 33

7. Remove the motor. Be careful not to damage the rubber splash shield. Proceed to step #10.
8. The polishing spindle motor has a face mount to an angle bracket as part of the spindle assembly. Remove the four Allen head set screws from the front of the motor after separating it from the base angle..
9. Install four Allen head set screws in the front of the new motor. Install the motor on the base and secure using four lock washers and screws.
10. Reconnect the electrical harness and wire motor following the tags applied in dis-assembly. Reinstall cover on electrical box.

SECTION 6

11. At the front of the machine, install the rubber splash shield and steel plate on four Allen head set screws and secure using four nuts. Use silicone sealant between the rubber and the face of the motor and between the trough and the rubber splash shield.
12. Place key in keyway of the motor shaft and install the hub. Secure the hub to the motor shaft with a washer and screw. Tighten the motor hub screw to 40 lbs-ft of torque. To prevent the motor shaft from turning, install a ¼-20 screw into the hub and wedge a screwdriver or small bar between the screw and the hub. Remove the screw from the hub. Position the wheel on the hub before tightening the Allen head screws to 20 lbs-ft of torque.
13. Put the main power switch located on the electrical control cabinet in the “ON” position.

WARNING!

Check the direction of rotation of the motor against the table below before putting any wheel into service. To reverse direction, reverse any two of the motor’s leads in the electrical control cabinet. Incorrect direction can cause equipment damage and personal injury.

MOTOR	ROTATION
Edging	Counterclockwise
Polishing	Counterclockwise

Before opening the electrical control cabinet door and performing any procedures in the electrical control cabinet, put the main power switch and main power source safety disconnect switch in the “OFF” position.

14. Start the machine by pressing the “START” switch on the operator’s station. Before making adjustments to the motors, you must have available several pieces of clean ¼ inch glass for the following setup and steps. The first adjustment requires a piece of glass at least 40 inches long and at least 10 inches wide so the operator can see the glass above the front tube conveyor as the glass moves into the machine.

ENTRY AND EXIT CONVEYORS

Every 40 Hours of Operation

The hour meter located on the right side of the control cabinet can be monitored to schedule the cleaning of the entry and exit conveyors and other maintenance.

1. Remove the guard from the entry or exit conveyor by removing the three thumbscrews and washers.
2. At the entry conveyor, use clean water with a wire brush to remove any glass grind residue from the drive unit, sprocket, tensioner and tensioner bracket.
3. At the exit conveyor, use clean water and a wire brush to remove any glass grind residue from the drive unit, sprocket, tensioner and tensioner bracket. If necessary, use a putty knife to remove any foreign matter from these parts.
4. If necessary, the conveyor belt can be removed for cleaning and to gain access to the groove on the pulley. To remove the conveyor belt:
 - a) Loosen the two screws securing the pulley yoke.
 - b) Loosen the tension adjusting screw to obtain slack in the conveyor belt, then slip the conveyor belt off of the pulley and remove.
5. Clean the top and bottom of the conveyor belt to remove foreign matter, using clean water while scrubbing with a hard bristle brush.
6. Remove any glass grind or slurry residue with a wire or other stiff bristle brush from the exterior of the pulleys, pulley grooves, pulley yokes and between the conveyor frame and the pulleys.
7. Remove all foreign matter from the conveyor housing and drain hose, using clean water. Check the drain hole for blockage and clean thoroughly.
8. Clean and remove all foreign matter from belt guide.
9. Lubricate the pulley on the pulley yoke with eight drops of SAE10W oil. Check for free rotation after re-assembly.
10. Install conveyor belt and adjust (see following section).

SECTION 6

Every 80 Hours of Operation or Less

Check and adjust the entry and exit conveyor belt tension:

1. If not already removed, remove the guard from the entry or exit conveyor by removing the three thumbscrews and washers.
2. Check at the middle of the bottom portion of the belt for a deflection of $\frac{3}{4}$ " or less. If the belt is in excess of this, adjust belt as described in the next steps.
3. Loosen the two screws securing the pulley yoke.
4. Tighten the tension adjusting screw until there is $\frac{3}{4}$ " or less belt deflection when the bottom portion of the belt is depressed in the middle.
5. Tighten the two screws that secure the pulley yoke.
6. Put the guard back on the conveyor assembly and secure with the three thumbscrews and washers.

FRONT AND REAR CHAIN ASSEMBLIES

Tighten Front and Rear Chain Assemblies

The front and rear chain pad adjustment screws are located on the left side of the beveller. After every 160 hours of operation, tighten the front and rear chain pads as follows:

1. Remove the guards.
2. Check the front and rear chain assemblies for slack.
3. At the front center of the machine, choose a pad. With a slight push, force it towards the machine. There should be about $\frac{1}{2}$ inch of slack when the pad is pushed towards the machine center.
4. To tighten the front chain assembly, tighten the nut (Figure 34) on the stud of the takeup assembly. There are two takeup assemblies; ensure that they are adjusted evenly.
5. To tighten the rear chain assembly, tighten the nut on the stud of the takeup assembly. There are two takeup assemblies; ensure that they are adjusted evenly.



Figure 34

Chain Assembly Pad Replacement

To replace a pad on the front or rear chain assembly:

1. Remove the guard.
2. Locate the damaged pad and turn the conveyor "ON" in order to position the damaged pad at a convenient place on the drive or idler sprocket.
3. Using a screwdriver, pry off the chain pad. If more than one pad is damaged, it may be easier to remove the entire chain from the machine and place it on a bench (see Figure 35).
4. This is done by locating the master link on the chain body. The back of the pad on the master link is painted red for locational purposes. Once the pad is removed, the master link can be taken off and the chain assembly can be taken off of the center section.



Figure 35

SECTION 6

FRONT AND REAR CHAIN ASSEMBLY LUBRICATION

Every 40 Hours of Operation

Chain lubrication is extremely important. Keep the chain lubricated with Sommer & Maca part number 29901671 chain lubricant. It is very important that other lubricants are not substituted as the special anti-wear properties of this lubricant were specifically designed for this application. Also apply oil to the (4) four idler sprockets in the center section of the chain assemblies.

After cleaning, apply Sommer & Maca part number 59900480 teflon grease to top and bottom portions of the chain and pad assemblies with a small brush (see Figure 36).

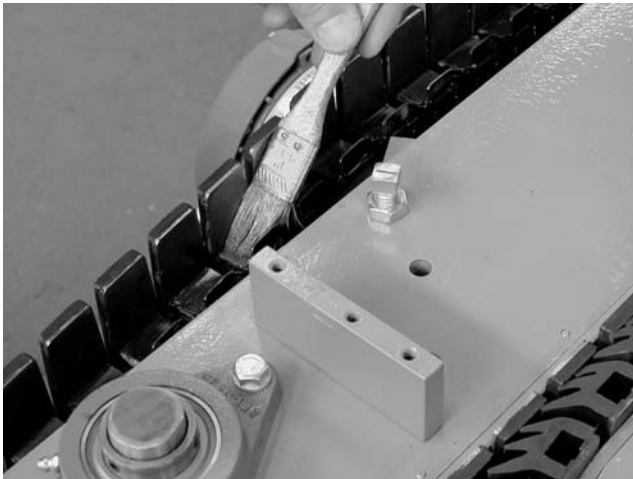

Figure 36

Using a grease gun with Sommer & Maca part number 59901594 special moly grease, pump a small amount of the grease into each fitting on the (7) seven sprocket and spur gear shaft flange bearings (see Figure 37). The flange bearing nearest to the large spur gears is located lower than the other six bearings. There are no bearings between the top of the gearboxes on either side of the center chain conveyors.

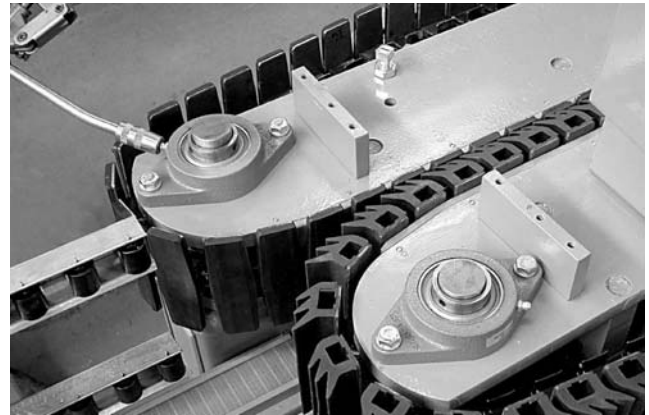

Figure 37

Coat the gear teeth of the large spur gears with the same grease, applied with a brush (see Figure 38).



Figure 38

After the first 100 hours of operation, drain the gearbox oil (see Figure 39) and refill with a SAE90 grade gear lube. After every 2500 hours of running, drain and refill. Also, grease the grease fitting as shown, every 120 hours. Note that there are two

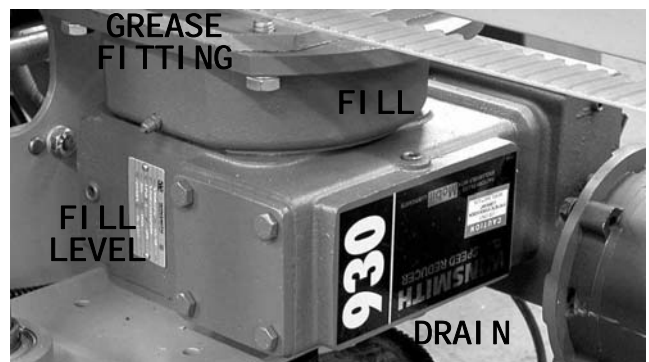

Figure 39

SECTION 6

gearbox sections, since this is a double reduction gearbox. The smaller gearbox is attached directly to the motor and has fill, drain and level plugs as shown in Figure 40. It also requires SAE90 gear lube.

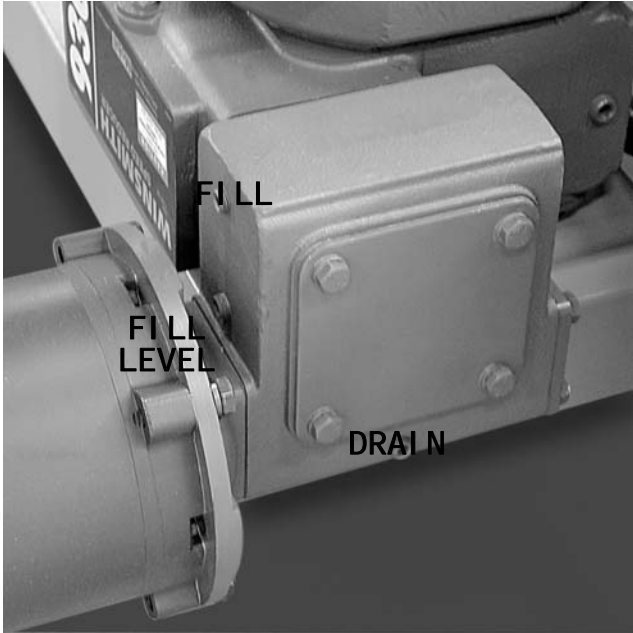

Figure 40

COOLANT SYSTEM

Every 8 Hours of Operation

1. Drain and clean the sediment tank and pump reservoir:
 - a) Disconnect the pump power cord.
 - b) Disconnect coolant recirculating hose from the coolant tank piping.
 - c) Remove the three screws that secure the pump to the coolant sediment tank and lift it from the reservoir.
 - d) Remove the two metal partitions from the coolant tank. Using a high pressure nozzle, flush the sediment from the partitions with clean water.
 - e) Drain the coolant and sediment from the tank.
 - f) Using a high pressure nozzle, flush the sediment from the tank with clean water.
 - g) Flush the pump and associated piping using a high pressure nozzle and clean water.
 - h) Reinstall the pump on the coolant tank.
 - i) Reinstall the two metal partitions in the coolant tank.
2. Clean all foreign matter from the chain assembly pads using a soft bristle brush and clean water.
 3. When the spray guard brushes are dry, run a thin stick or similar tool back and forth between the bristles to clean the buildup of glass grind. The brushes can be removed for more thorough cleaning if necessary.
 4. Flush all lines and the center coolant trough section below the grinding and smoothing wheels with clean water.

CAUTION!

Always mix the coolant as recommended by the manufacturer. Using less coolant can cause excessive wheel wear, rusting of machinery parts and, in general, damage the edger.

5. Refill the coolant tank with a mixture of one part of SOMACA diamond wheel coolant, part number 265-1008, or equivalent, to 80 parts of clean water, or as recommended. The tank capacity is 14 gallons when filled one inch below the top of the tank. This will require 22½ ounces of SOMACA diamond wheel coolant. The coolant improves the finish of the grinding and smoothing operations, inhibits rust formation on the edger parts and helps preserve the rubber parts.

Coolant Line Positioning

Each grinding and polishing wheel requires a coolant line. These coolant lines should always be checked daily to ensure unrestricted flow.

SECTION 6

DRESSING GRINDING WHEELS

NOTE

The following steps describe the process for dressing the diamond grinding wheels using stones designed for this purpose. Diamond wheels, depending upon the manufacturer and base metal bond, vary considerably in service life from one half million to over one and one half million linear inches.

A good indication that a wheel needs dressing is an increase of 3 amperes or more in motor current draw, jumping of the ammeter, or fluctuation in the ammeter reading. When any of these conditions occurs, the groove in the wheel must be dressed.

WARNING!

Always start and stop the motor and apply the dressing tool as the motor is ramping down. Application of the dressing tool when the motor is under power is dangerous. Apply the stone to the side of the wheel that is rotating upward. Wear heavy leather gloves, protective clothing and eye protection when dressing wheels. Avoid contact with the moving wheel. Failure to exercise these precautions could cause serious injury.

Be extremely careful while performing the dressing operations. Dressing stones wear quickly. Do not hold your fingers opposite the wheel on the dressing stone. Do not allow the wheel to cut off a piece of the stone as it could act as a projectile and cause serious injury.

CAUTION!

Never attempt to dress a diamond wheel with a dry stone. Either have the coolant pump ON or wet the stone thoroughly before applying the stone to the wheel. The material from the wheel, unless washed away during dressing, will plug the pores of the diamond wheel and inhibit the shaping process.

Diamond Grinding Wheel

1. The procedure for dressing a diamond grinding wheel:
 - a) Start the edger by depressing the START switch.
 - b) At the wheel to be dressed, allow the motor to come to full speed and then press the switch to the STOP position. While the motor is coasting to a stop, apply the dressing stone (see Figure 41) firmly against the working surface of the wheel (see Figure 42). Make sure the stone contacts the entire working area of the wheel. The wheels cut primarily on the inside edges.



Figure 41



Figure 42

SECTION 6

- c) Repeat the previous steps three or four times to complete the dressing process. When the wheel cuts the stone freely, the dressing procedure is done.

Polishing Wheel

Polishing wheels are made of a composite material, rather than the metal that is used in the grinding wheels. They do require periodic edge dressing if the polishing wheel is overheated due to lack of coolant or excessive cutting loads. The face will become glazed over and it will be necessary to remove this glaze. Also, a new wheel will require the contour to be grooved in before being able to be put it into service. This procedure is as follows:

WARNING!

Always start and stop the motor and apply the dressing tool as the motor is ramping down. Application of the dressing tool when the motor is under power is dangerous. Apply the stone to the side of the wheel that is rotating upward. Wear heavy leather gloves, protective clothing and eye protection when dressing wheels. Avoid contact with the moving wheel. Failure to exercise these precautions could cause serious injury.

1. Visually inspect the wheel for glazing, or, if it is a new wheel, any obvious signs of damage. To wear the wheel in:
 - a) Start the edger by depressing the START switch.
 - b) While running glass through the machine, adjusting the polishing wheel spindle upwards until the entire edge is polished.
 - c) Repeat the previous step as many times as is required. For some polishing wheels, this can be a time consuming process. An alternate method is described in the next step.
2. Visually inspect the face of the wheel on the cup face. If a glazing is present:
 - a) Start the beveller by depressing the START switch.
 - b) Run a dressing board (Figure 41) through the grinding and polishing wheels while adjusting the polishing wheel spindle upwards. The board will be ground to shape by the diamond wheel and the polishing wheel will be dressed to the same shape as it passes through the edger.
 - c) Repeat the previous steps three or four times to complete the dressing process and ensure that the groove is deep enough.

In both methods turn the coolant pump ON to start the flow of coolant. Press both spindle 1 and 2 start buttons to start the operation of the wheels. Turn the conveyor ON.

The latter method is obviously faster but it can be more damaging to the diamond grinding wheel due to the hard abrasive material the the dressing board is comprised of.

SECTION 7

TROUBLESHOOTING

PROBLEM	POSSIBLE SOLUTION
Motor ammeters read over 5 amperes or higher than normal	<ol style="list-style-type: none">1. Dress the wheels2. Re-true the diamond wheel3. Slow down the conveyor speed4. Tighten the conveyor with the takeup and lubricate the chain5. Check the position of the coolant lines
Glass rides up in the main section conveyor	<ol style="list-style-type: none">1. Dress the wheels2. Check the infeed and outfeed conveyors for level3. Check the outfeed conveyor for glass interference4. Check the conveyor pads for damage due to overcompression or unevenness5. Slow down the conveyor speed6. Check the racks or rollers for glass interference7. Check infeed sprocket alignment with the tracks
Choppy edge	<ol style="list-style-type: none">1. Check the outfeed conveyor for glass interference2. Re-dress diamond wheel and polishing wheel3. Slow down the conveyor4. Re-true diamond wheel5. Check the tightness of the motor mount and adjustment locking screws6. Check the coolant lines
Chipped edge or starred edge	<ol style="list-style-type: none">1. Is the wheel profile suitable for the glass thickness? Try a different profile2. Make sure the wheel is not turned too far so the steel body is contacting the glass3. Is the wheel worn out? Try a new or retrued wheel4. Try a finer grit diamond wheel5. Slow down the conveyor speed
Glass drops in conveyor	<ol style="list-style-type: none">1. Check the infeed and outfeed conveyor levels2. Check the outfeed conveyor for glass interference Check the conveyor pads for damage3. Are all of the rubber pads in place?
Motor ammeters increase or decrease substantially on long pieces of glass	<ol style="list-style-type: none">1. Level the infeed and outfeed conveyors2. Dress the wheels3. Check the outfeed conveyor for glass interference4. Check the coolant line positioning5. Is ther cut glass straight or are there large flares?

WARRANTY STATEMENT

SOMMER & MACA Industries, Inc. (Seller) warrants the products of its manufacture to be free from defects in materials and workmanship in normal use for six months from the date of shipment unless a shorter period is provided elsewhere in this document. The Seller's obligation and Buyer's exclusive remedy shall be limited to the repair or replacement, at the Seller's option, of defective parts within the warranty period, provided the Buyer gives the Seller immediate written notice of such alleged defects, and if requested by the Seller, returns the defective parts to the Seller's factory for the Seller' inspection.

The warranties contained herein are in lieu of any other warranty, expressed or implied, including any warranty of MERCHANTABILITY OR FITNESS FOR PURPOSE.

In the case of equipment furnished by the Seller but not of the Seller's manufacturer, the Seller's liability to the Buyer hereunder is limited to such adjustment as the manufacturer thereof makes to the Seller. The Seller shall, in no event, be liable for consequential damages.

Warranties hereunder shall not apply to any equipment that shall have been damaged by misuse, neglect, failure to perform maintenance, or accident after the shipment thereof by the Seller. In addition thereto, this warranty shall be null and void if the (1) machine is used in a manner contrary to instruction or after malfunction is noticed, (2) the Buyer does not honor the terms of payment, or (3) the machine is modified or altered without the agreement of the Seller.