

# Vehicle Equipment and Inspection Regulations

Copyright © 2020 by the Commonwealth of Pennsylvania.  
All Rights Reserved.

# TABLE OF CONTENTS

## SUBCHAPTER A

### GENERAL PROVISIONS

175.1	Purpose . . . . .	1
175.2	Definitions . . . . .	1
175.3	Application of Equipment Rules . . . . .	5
175.4	Vehicles Required to be Inspected . . . . .	6
175.5	Semi-Annual Inspection . . . . .	6
175.6	Annual Inspection . . . . .	6
175.7	Inspection of Vehicles Reentering this Commonwealth . . . . .	6
175.8	Newly-Purchased Vehicles . . . . .	6
175.9	Vehicles Registered in Another State . . . . .	7
175.10	Vehicles Requiring Emission Inspection Due to Address Change . . . . .	7
175.11	Coordination of Safety and Emission Inspection . . . . .	7

## SUBCHAPTER B

### OFFICIAL INSPECTION STATION REQUIREMENTS

175.21	Appointment . . . . .	8
175.22	Making Application . . . . .	8
175.23	Approval . . . . .	9
175.24	Required Certificates and Station Signs . . . . .	9
175.25	Inspection Area . . . . .	9
175.26	Tools and Equipment . . . . .	10
175.27	Hours . . . . .	11
175.28	Certified Inspection Mechanics . . . . .	11
175.29	Obligations and Responsibilities of Stations . . . . .	12
175.30	Commonwealth Inspection Stations . . . . .	14
175.31	Fleet Inspection Stations . . . . .	15
175.32	Recreational and Utility Trailer Inspection Stations . . . . .	15
175.33	Motorcycle Inspection Stations . . . . .	15
175.34	General Inspection Stations . . . . .	15
175.35	Enhanced Vehicle Safety Inspection Stations . . . . .	16

## SUBCHAPTER C

### CERTIFICATE OF INSPECTION

175.41	Procedure . . . . .	17
175.42	Recording Inspection . . . . .	19
175.43	Security . . . . .	21
175.44	Ordering Certificates of Inspection . . . . .	22
175.45	Violation of Use of Certificate of Inspection . . . . .	23

## SUBCHAPTER D

### SCHEDULE OF PENALTIES & SUSPENSIONS: Official Inspection Stations & Certified Mechanics

175.51	Cause for Suspension . . . . .	24
175.52	Reapplication . . . . .	27

**SUBCHAPTER E**

---

**PASSENGER CARS AND LIGHT TRUCKS**

175.61	Application of Subchapter . . . . .	28
175.62	Suspension . . . . .	28
175.63	Steering . . . . .	28
175.64	Braking Systems . . . . .	28
175.65	Tires and Wheels . . . . .	28
175.66	Lighting and Electrical Systems . . . . .	29
175.67	Glazing . . . . .	31
175.68	Mirrors . . . . .	32
175.69	Windshield Defrosters . . . . .	32
175.70	Windshield Washers . . . . .	32
175.71	Windshield Wipers . . . . .	32
175.72	Fuel Systems . . . . .	33
175.73	Speedometers . . . . .	33
175.74	Odometers . . . . .	33
175.75	Exhaust Systems . . . . .	33
175.76	Horns and Warning Devices . . . . .	33
175.77	Body . . . . .	34
175.78	Chassis . . . . .	34
175.80	Inspection Procedure . . . . .	35
175.80(a)	External Inspection . . . . .	35
175.80(b)	Internal Inspection . . . . .	38
175.80(c)	Under the Hood Inspection . . . . .	39
175.80(d)	Visual Inspection of Emission Control System . . . . .	39
175.80(e)	Beneath the Vehicle Inspection . . . . .	40
175.80(f)	Road Test . . . . .	42

**SUBCHAPTER F**

---

**MEDIUM AND HEAVY TRUCKS, BUSES AND SCHOOL BUSES**

175.91	Application of Subchapter . . . . .	43
175.92	Suspension . . . . .	43
175.93	Steering . . . . .	43
175.94	Braking Systems . . . . .	43
175.95	Tires and Wheels . . . . .	44
175.96	Lighting and Electrical Systems . . . . .	44
175.97	Glazing . . . . .	46
175.98	Mirrors . . . . .	47
175.99	Windshield Defrosters . . . . .	48
175.100	Windshield Washers . . . . .	48
175.101	Windshield Wipers . . . . .	48
175.102	Fuel Systems . . . . .	48
175.103	Speedometers . . . . .	48
175.104	Odometers . . . . .	48
175.105	Exhaust Systems . . . . .	48
175.106	Horns and Warning Devices . . . . .	49
175.107	Body . . . . .	49
175.108	Chassis . . . . .	50
175.110	Inspection Procedure . . . . .	51
175.110(a)	External Inspection . . . . .	51
175.110(b)	Internal Inspection . . . . .	54
175.110(c)	Under the Hood Inspection . . . . .	56

**MEDIUM AND HEAVY TRUCKS, BUSES AND SCHOOL BUSES (continued)**

175.110(d)	Beneath the Vehicle Inspection . . . . .	57
175.110(e)	Road Test . . . . .	60

**SUBCHAPTER G****RECREATIONAL, SEMI - AND UTILITY TRAILERS**

175.121	Application of Subchapter . . . . .	61
175.122	Suspension . . . . .	61
175.123	Braking Systems . . . . .	61
175.124	Tires and Wheels . . . . .	61
175.125	Lighting and Electrical Systems . . . . .	62
175.126	Glazing . . . . .	62
175.127	Body . . . . .	62
175.128	Chassis . . . . .	63
175.130	Inspection Procedure . . . . .	63
175.130(a)	External Inspection . . . . .	63
175.130(b)	Internal Inspection . . . . .	65
175.130(c)	Beneath the Vehicle Inspection . . . . .	65
175.130(d)	Road Test . . . . .	67

**SUBCHAPTER H****MOTORCYCLES**

175.141	Application of Subchapter . . . . .	68
175.142	Suspension . . . . .	68
175.143	Steering . . . . .	68
175.144	Braking Systems . . . . .	68
175.145	Tires and Wheels . . . . .	69
175.146	Lighting and Electrical Systems . . . . .	69
175.147	Glazing . . . . .	71
175.148	Mirrors . . . . .	71
175.149	Fuel Systems . . . . .	71
175.150	Speedometers . . . . .	72
175.151	Odometers . . . . .	72
175.152	Exhaust Systems . . . . .	72
175.153	Horns and Warning Devices . . . . .	72
175.154	Body . . . . .	72
175.155	Chassis . . . . .	72
175.160	Inspection Procedure . . . . .	73
175.160(a)	External Inspection . . . . .	73
175.160(b)	Internal Inspection . . . . .	75
175.160(c)	Beneath the Vehicle Inspection . . . . .	76
175.160(d)	Road Test . . . . .	77

**SUBCHAPTER J****MOTOR-DRIVEN CYCLES AND MOTORIZED PEDALCYCLES**

175.171	Application of Subchapter . . . . .	79
175.172	Steering . . . . .	79
175.173	Braking Systems . . . . .	79
175.174	Tires and Wheels . . . . .	79
175.175	Lighting and Electrical Systems . . . . .	80

**MOTOR-DRIVEN CYCLES AND MOTORIZED PEDALCYCLES (continued)**

175.176	Glazing . . . . .	81
175.177	Mirrors . . . . .	82
175.178	Fuel Systems . . . . .	82
175.179	Speedometers . . . . .	83
175.180	Odometers . . . . .	83
175.181	Exhaust Systems . . . . .	83
175.182	Horns and Warning Devices . . . . .	83
175.183	Body . . . . .	83
175.184	Chassis . . . . .	83
175.190	Inspection Procedure . . . . .	84
175.190(a)	External Inspection . . . . .	84
175.190(b)	Internal Inspection . . . . .	86
175.190(c)	Beneath the Vehicle Inspection . . . . .	86
175.190(d)	Road Test . . . . .	87
175.190(e)	Exemption . . . . .	87

**SUBCHAPTER K**

---

**STREET RODS, SPECIALLY CONSTRUCTED AND RECONSTRUCTED VEHICLES**

175.201	Application of Subchapter . . . . .	89
175.202	Conditions . . . . .	89
175.203	Braking Systems . . . . .	89
175.204	Tires . . . . .	89
175.205	Lighting and Electrical Systems . . . . .	89
175.206	Glazing . . . . .	89
175.207	Mirrors . . . . .	90
175.208	Body . . . . .	90
175.209	Chassis . . . . .	90
175.210	Unconventional Operator Location . . . . .	90
175.211	Inspection . . . . .	91
175.220	Inspection Procedure . . . . .	91
175.220(a)	External Inspection . . . . .	91
175.220(b)	Internal Inspection . . . . .	92
175.220(c)	Under the Hood Inspection . . . . .	92
175.220(d)	Beneath the Vehicle Inspection . . . . .	93

**SUBCHAPTER L**

---

**ANIMAL-DRAWN VEHICLES, IMPLEMENTS OF HUSBANDRY AND SPECIAL MOBILE EQUIPMENT**

175.221	Application of Subchapter . . . . .	94
175.222	Steering . . . . .	94
175.223	Braking Systems . . . . .	94
175.224	Tires and Wheels . . . . .	94
175.225	Lighting and Electrical Systems . . . . .	95
175.226	Glazing . . . . .	96
175.227	Mirrors . . . . .	96
175.228	Fuel Systems . . . . .	96
175.229	Exhaust Systems . . . . .	97
175.230	Horns and Warning Devices . . . . .	97

**SUBCHAPTER M****ALTERNATE FUEL SYSTEMS AND CONTROLS**

175.241	Compressed and Liquefied Gas Fuel Systems . . . . .	98
175.242	Inspection of Fuel System and Controls . . . . .	106

**SUBCHAPTER O****VEHICLE SUN SCREENING DEVICES**

175.261	Scope . . . . .	107
175.262	Applicability . . . . .	107
175.263	Sun Screening Location . . . . .	107
175.264	Mirrors . . . . .	107
175.265	Exemption Provisions . . . . .	107

**TABLES**

Table I	Brake Performance . . . . .	Table-1
Table II	Required Motor Vehicle Lighting Equipment . . . . .	Table-2
Table III	Location of Required Equipment . . . . .	Table-3
Table IV	Required Motor Vehicle Lighting Equipment . . . . .	Table-4
Table V	Location of Required Equipment . . . . .	Table-5
Table VI	Vehicle Glazing . . . . .	Table-7
Table VII	Vehicle Glazing . . . . .	Table-8
Table VIII	Vehicle Glazing . . . . .	Table-9
Table IX	Vehicle Glazing . . . . .	Table-9
Table X	Acceptable Light Transmittance Levels for Vehicle Glazing. . . . .	Table-10

**APPENDIX A****MINIMUM REQUIREMENTS FOR MOTOR VEHICLE BRAKE LININGS - SAE**

J998 SAE Recommended Practice . . . . .	APP-1
---	-------

**APPENDIX B****MOTORCYCLE AND MOTOR VEHICLE CYCLE ELECTRICAL SYSTEM (Maintenance of Design Voltage)**

SAE J392 SAE Recommended Practice . . . . .	APP-1
---	-------

**APPENDIX C**

RESERVED . . . . .	APP-2
--------------------	-------

**REFERENCE MATERIAL**

Chart 1:	Headlight Aiming Screen Distance & Marking Identification . . . . .	REF-1
Chart 2:	High Beam Inspection Limits . . . . .	REF-2
Chart 3:	Low Beam Inspection Limits . . . . .	REF-2
Chart 4:	Brake Chamber Push Rod Travel (typical) . . . . .	REF-3
Chart 5:	Scrub Line (Street Rods, Specially Constructed and Reconstructed Vehicles). . . . .	REF-4
	Brakes . . . . .	REF-6
	Tires . . . . .	REF-10
	Steering System . . . . .	REF-11
	Suspension System . . . . .	REF-12



## Subchapter A

### GENERAL PROVISIONS

#### 175.1. Purpose

This chapter implements 75 Pa.C.S. §§4101-4982, (relating to vehicle characteristics).

#### 175.2. Definitions

The following words and terms, when used in this chapter, have the following meanings, unless the context clearly indicates otherwise:

**ASME Code** - The American Society of Mechanical Engineers Boiler and Pressure Vessel Code; Section VIII, Division I, and Section IX of the 1971 and later editions.

**ASTM** - The American Society for Testing and Materials.

**Acute Area of the Windshield** - The center of the critical area on the driver's side of the vehicle directly in the driver's normal line of vision 8 1/2 inches wide and 5 1/2 inches high.

**Allowable Working Pressure** - The pounds per square inch for which the container was constructed, or if conditions have changed, the maximum pressure at specified temperatures permitted at the most recent inspection by a certified inspector.

**Alteration** - A change in the construction, design, or installation of a container that affects the strength or safety of the system.

**Antique Motor Vehicle** - The term as defined in 75 Pa.C.S. § 102 (relating to definitions).

**Auxiliary Driving Lamp** - A lighting device mounted to provide illumination in front of the vehicle and to supplement the upper beam of a standard headlamp system; it is not intended for use alone or with the lower beam of a standard headlamp system.

**Back-Up Lamp** - A lamp used to provide illumination behind the vehicle and to provide a warning signal when the vehicle is in reverse gear.

**Bead** - The part of the tire made of steel wires wrapped or reinforced by ply cords, that is shaped to fit the rim.

**Belt** - A layer made of fabric or other material located under the tread area.

**Bureau** - The Bureau of Motor Vehicles of the Department.

**Bus** - A motor vehicle as defined in 75 Pa.C.S. § 102 (relating to definitions).

**CGA** - The Compressed Gas Association, Inc.; 14501 George Carter Way, Suite 103, Chantilly, VA 20151.

**Cargo Lamp** - A lamp mounted on a multipurpose passenger vehicle, truck or bus that provides illumination to load or unload cargo.

**Certified Inspection Mechanic** - A person who holds a valid certification card issued by the Bureau certifying that the person is qualified, has passed all requirements to inspect specific vehicles and holds a valid driver's license for the correct class of vehicle.

**Certified Inspector** - A person who holds a certificate issued by the Boiler Division in the Bureau of Occupation and Industrial Safety within the Department of Labor and Industry certifying that the person is qualified to inspect unfired pressure vessels.

**Classic Motor Vehicle** - The term as defined in 75 Pa.C.S. § 102 (relating to definitions).

**Clearance Lamps** - Lamps which show to the front or rear of a vehicle to indicate overall width and height of a vehicle—on trucks and buses 80 inches or more in width.

**Collectible Motor Vehicle** - The term as defined in 75 Pa.C.S. § 102.

**Combination** - The term as defined in 75 Pa.C.S. § 102.

**Commonwealth Inspection Station** - An inspection station appointed to inspect all types of vehicles, space permitted, owned by and engaged exclusively in the performance of the official duties of the Federal Government, the Commonwealth, or a political subdivision of the Commonwealth.



## Subchapter A - General Provisions

---

**Cord** - The strands forming the plies in the tire.

**Critical Area of the Windshield** - The part of the vehicle windshield cleaned by the sweep of the windshield wiper system.

**DOT** - The United States Department of Transportation.

**Department** - The term as defined in 75 Pa.C.S. § 102.

**Designated Area** - The geographic area which the Department, in conjunction with the Department of Environmental Resources, and the United States Environmental Protection Agency, has identified as an Emission I/M Program designated area. A copy of the Department's designation is available upon request from the Department.

**Driveaway-Towaway Operation** - The term as defined in 75 Pa.C.S. § 102.

**Emergency Vehicle** - As defined in 75 Pa.C.S. §102.

**Essential Parts** - The term as defined in 75 Pa.C.S. § 102.

**FMVSS** - Federal Motor Vehicle Safety Standards in 49 C.F.R. Part 571 (relating to Federal Motor Vehicle Safety Standards).

**Farm Vehicle** - The term as defined in 75 Pa.C.S. § 102.

**Firefighting Vehicle** - A vehicle used exclusively for fighting fires. The term does not include passenger cars, buses and motorcycles.

**Fleet Inspection Station** - An inspection station appointed to inspect all types of vehicles, space permitting, leased by or owned and registered in the name of the person in whose name the certificate of appointment is issued.

**Fleet Owner** - The term as defined in 75 Pa.C.S. § 102.

**Fog Lamps** - Lamps which are used with or in lieu of the lower beam headlamps to provide illumination under conditions of rain, snow or fog.

**Foreign Vehicle** - The term as defined in 75 Pa.C.S. § 102.

**Fuel Supply Container** - A tank or cylinder installed on a vehicle to supply fuel for the propulsion system of the vehicle.

**GCWR - Gross Combination Weight Rating** - The term as defined in 75 Pa.C.S. § 102.

**GVWR - Gross Vehicle Weight Rating** - The term as defined in 75 Pa.C.S. § 102.

**General Inspection Station** - An inspection station appointed to inspect all types of vehicles if the station is so equipped.

**Groove** - The space between two adjacent tread ribs.

**Gross Weight** - The term as defined in 75 Pa.C.S. § 102.

**Hazard Warning System or Emergency Signal System** - A driver-controlled system of flashing front and rear lights used to warn approaching motorists when a car has broken down or is traveling at a slow speed.

**Heavy Truck** - A truck having a registered gross weight in excess of 17,000 pounds or a truck tractor.

**House Trailer** - The term as defined in 75 Pa.C.S. § 102.

**ICC** - The Interstate Commerce Commission; now functionally superseded by DOT in matters relating to safety.

**Identification Lamps** - Lamps used in groups of three, in a horizontal row, which show to the front or rear, or both, on vehicles 80 inches or more in width.

**Implement of Husbandry** - The term as defined in 75 Pa.C.S. §102.

**Indicator Lights** - Lamps that are visible to the operator of a vehicle that indicate operation of appropriate electrical circuits, malfunction of vehicle performance and requirement for remedial action by the operator of the vehicle.

**Inspection Area** - The area of a station in which all inspections must be conducted.

**Inspection/Maintenance (I/M) Insert Tab** - A number tab, applied to the safety certificate of inspection, which indicates the month in which the safety certificate of inspection expires and that the vehicle is subject to the Emission Inspection Program.

**Inspection/Maintenance (I/M) Registration Indicator** - An indicator on the registration card which identifies the vehicle as a subject vehicle which shall be emission inspected annually.

**Inspection Station Supervisor** - Any person designated by the Department to investigate, inspect and supervise the operation of inspection stations.

**License Plate Lamp** - A lamp used to illuminate the license plate on the rear of the vehicle.

**Light Truck** - A truck having a registered gross weight of 11,000 pounds or less.

**Manufacturer** - The term as defined in 75 Pa.C.S. § 102.

**Mass Transit Vehicle** - The term as defined in 75 Pa.C.S. § 102.

**Material Which Does Not Permit a Person to See or View the Inside of the Vehicle** - A material which reduces the transmittance of light to below 70% or to a percentage which is less than the percentage permitted by FMVSS #205 in effect at the time of the vehicle's manufacture.

**Medium Truck** - A truck having a registered gross weight from 11,001 to 17,000 pounds, inclusive.

**Mobile Home** - The term as defined in 75 Pa.C.S. § 102.

**Modular Housing Undercarriage** - The term as defined in 75 Pa.C.S. § 102.

**Modular Housing Unit** - The term as defined in 75 Pa.C.S. § 102.

**Motor Carrier Vehicle** - A truck, truck-tractor or combination having a gross weight or registered gross weight in excess of 17,000 pounds.

**Motorcycle** - The term as defined in 75 Pa.C.S. § 102.

**Motorcycle Inspection Station** - An inspection station appointed to inspect only motorcycles.

**Motor-Driven Cycle** - A motorcycle, including a motor scooter, with a motor which produces not to exceed five-brake horsepower, and every pedalcycle with a motor attached.

**Motor Home** - The term as defined in 75 Pa.C.S. § 102.

**Motorized Pedalcycle** - The term as defined in 75 Pa.C.S. § 102.

**Motor Vehicle** - The term as defined in 75 Pa.C.S. § 102.

**Multi-Purpose Passenger Vehicle** - A passenger car which is constructed on a truck chassis or which has special features for off-road use, in addition to highway use.

**NHTSA** - The National Highway Traffic Safety Administration, Washington, D.C.

**NFPA** - The National Fire Protection Association; 470 Atlantic Avenue; Boston, Massachusetts 02210.

**Ornamental Lamps** - Lamps not required and not located as described in Tables III, IV and V of this chapter, unless available as original equipment. Flashing or revolving lights are not ornamental lamps. Flashing or revolving lights and their use are addressed in Chapters 15 and 173 (relating to authorized vehicles and special operating privileges; and flashing or revolving lights on emergency and authorized vehicles).

**Parking Brake System** - A brake system used to hold and maintain a vehicle in a stationary position. A positive mechanical means is employed to hold the brake applied when the vehicle is unattended.

**Parking Lamps** - Steady-burning, low intensity lights used when a vehicle is stopped or parked.

**Passenger Car** - The term as defined in 75 Pa.C.S. § 102.

**Pedalcycle** - The term as defined in 75 Pa.C.S. § 102.

**Person** - The term as defined in 75 Pa.C.S. § 102.

**Ply** - A layer of rubber-coated parallel cords.

## Subchapter A - General Provisions

---

**Pole Trailer** - A trailer, including those with a variable wheelbase, attached to the towing vehicle by means of a reach or pole, or by being boomed or otherwise secured to the towing vehicle, and ordinarily used for transporting long or irregular-shaped loads, including poles, pipes or structural members capable of sustaining themselves as beams between the supporting connections.

**Rake** - On motorcycles, the angle, measured in degrees, of a motorcycle's steering axis in relation to a line which is perpendicular to the vehicle wheel base; on passenger cars or trucks the ground clearance at the front or rear of a vehicle, reduced or increased, giving tilted appearance.

**Reconstructed Vehicle** - The term as defined in 75 Pa.C.S. § 102.

**Recreational Trailer** - The term as defined in 75 Pa.C.S. § 102.

**Recreational and Utility Trailer Inspection Station** - An inspection station appointed to inspect only recreational and utility trailers.

**Reflex Reflectors** - A reflective device used for reflecting light, usually built into a lens.

**Registered Gross Weight** - The term as defined in 75 Pa.C.S. § 102.

**Registration** - The term as defined in 75 Pa.C.S. § 102.

**Renewed Emissions Certificate of Inspection** - An emissions certificate of inspection that remains valid for more than 90 days.

**Safety Insert Tab** - A numbered tab, applied to the Safety Certificate of Inspection, which indicates the month in which the Safety Certificate of Inspection expires.

**School Bus** - The term as defined in 75 Pa.C.S. § 102.

**Secretary** - The term as defined in 75 Pa.C.S. § 102.

**Semitrailer** - The term as defined in 75 Pa.C.S. § 102.

**Service Brake System** - A brake system used for retarding, stopping and controlling the vehicle under normal operating conditions.

**Side Marker Lamps** - Lamps located on the left and right sides, beamed and intended to indicate vehicle length.

**Snow Plow Lamp** - A lamp used in substitution of headlamps on vehicles equipped with snow plows.

**Special Mobile Equipment** - The term as defined in 75 Pa.C.S. § 102.

**Specially Constructed Vehicle** - The term as defined in 75 Pa.C.S. § 102.

**Stop Lamp** - A lamp at the rear of the vehicle which indicates the brake is being applied by the operator to slow or stop the vehicle.

**Street Rod** - The term as defined in 75 Pa.C.S. § 102.

**Subject Vehicle** - A gasoline powered vehicle with a gross vehicle weight rating of 9,000 pounds or less, moved upon a highway and registered or titled in a designated area, as defined in Chapter 177 (relating to Emission Inspection Program), except any of the following:

- (i) Special mobile equipment.
- (ii) An implement of husbandry.
- (iii) A motor vehicle being towed.
- (iv) A motor vehicle being driven or towed by an official inspection station owner or employee for the purpose of inspection.
- (v) A classic motor vehicle.
- (vi) An antique motor vehicle.
- (vii) A motorcycle.
- (viii) A motorized pedalcycle.

- (vix) A motor-driven cycle.
- (x) A street rod.
- (xi) A vehicle being repossessed by a financier or collector/repossessor through the use of a miscellaneous motor vehicle business registration plate.
- (xii) A new vehicle while they are in the process of manufacture including testing and not in transit from the manufacturer to a purchaser or dealer.
- (xiii) A military vehicle used for training by a private, nonprofit, tax exempt military educational institution when the vehicles do not travel on public roads in excess of 1 mile and when the property on both sides of the public road is owned by the institution.
- (xiv) A school bus over 11,000 pounds gross vehicle weight rating.
- (xv) A bus, other than school bus, with a seating capacity of 27 or more.

**Supply Line** - The piping, tubing or hose, including all related fittings, through which vapor or liquid passes between the first shut-off valve at the container and the final stage regulator or vaporizer.

**Suspend** - The term as defined in 75 Pa.C.S. § 102.

**Tail Lamp** - A steady burning low-intensity light used on the rear of a vehicle.

**Taxi** - The term as defined in 75 Pa.C.S. § 102.

**Temporary Inspection Approval Indicator** - An adhesive insert affixed to the current certificate of safety inspection, as viewed from inside the vehicle, used to designate vehicles which have successfully passed a required periodic safety inspection, but do not display a renewed emission certificate of inspection.

**Tire Width** - The term as defined in 75 Pa.C.S. § 102.

**Trail** - The distance measured in inches between the point at which the steering axis of a motorcycle intersects with the ground in front of the motorcycle and the point at which the forward limit of the wheel base intersects with the surface below the motorcycle.

**Trailer** - The term as defined in 75 Pa.C.S. § 102.

**Trailer Inspection Station** - An inspection station appointed to inspect only trailers.

**Tread** - That portion of the tire that comes into contact with the road.

**Tread Rib** - The tread section running circumferentially around the tire.

**Truck** - The term as defined in 75 Pa.C.S. § 102.

**Truck-Camper** - The term as defined in 75 Pa.C.S. § 102.

**Truck Tractor** - The term as defined in 75 Pa.C.S. § 102.

**Turn Signals** - A lamp showing to front and rear for the purpose of indicating an intention to turn either to the right or left or for pulling into traffic or changing lanes.

**UL** - The Underwriter's Laboratories, Inc.

**Utility Trailer** - The term as defined in 75 Pa.C.S. § 102.

**(VIN) Vehicle Identification Number** - The term as defined in 75 Pa.C.S. § 102.

**Vehicle** - The term as defined in 75 Pa.C.S. § 102.

**Vehicle Inspection Division** - The area of the Bureau which administers vehicle equipment and inspection matters.

### **175.3. Application of Equipment Rules.**

Equipment rules apply to vehicles operated on a highway, unless specifically exempted by this chapter.

#### **175.4. Vehicles Required to be Inspected**

A registered vehicle moved upon a highway shall bear a valid certificate of inspection except for the following:

- (1) Special mobile equipment.
- (2) An implement of husbandry.
- (3) A motor vehicle being towed.
- (4) A motor vehicle being driven or a trailer being towed by an official inspection station owner or employee for the purpose of inspection.
- (5) A trailer having a registered gross weight of 3,000 pounds or less.
- (6) A motorized pedalcycle.
- (7) A vehicle being repossessed by a financier or collector-repossessor through the use of miscellaneous motor vehicle business registration plates.
- (8) A new vehicle while it is in the process of manufacture including testing, and not in transit from the manufacturer to a purchaser or dealer.
- (9) A military vehicle used for training by a private, nonprofit, tax-exempt military educational institution when the vehicle does not travel on public roads in excess of 1 mile and when the property on both sides of the public road is owned by the institution.
- (10) An antique vehicle.

#### **175.5. Semiannual Inspection**

School buses, vehicles which are under contract with or owned by a school district or a private or parochial school, including vehicles having chartered group and party rights under the Public Utility Commission and used to transport school students; passenger vans used to transport persons for hire or owned by a commercial enterprise and used for the transportation of employees to or from their place of employment; and mass transit vehicles and motor carrier vehicles with a registered gross weight in excess of 17,000 pounds, other than farm vehicles for which a biennial certificate of exemption has been issued shall be subject to semi-annual inspection.

#### **175.6. Annual Inspection**

Other vehicles, including motor homes, emergency vehicles and private noncommercial vehicles used to transport students, shall be inspected annually. Motor homes and emergency vehicles built on a truck chassis shall be inspected according to the appropriate truck inspection procedure based on the registered gross weight of the vehicle.

**NOTE:** Effective February 2, 2017, Section 4702(b)(7) of the Vehicle Code, Requirement for Periodic Inspection of Vehicles is amended. Motor carrier vehicles with a registered gross weight in excess of 17,000 pounds, other than farm vehicles for which a biennial certificate of exemption has been issued, will now be inspected on an **annual basis**, instead of semiannually.

#### **175.7. Inspection of Vehicle Reentering this Commonwealth**

A vehicle subject to inspection which has been outside this Commonwealth continuously for 30 days or more and which, at the time of reentering this Commonwealth, does not bear a currently valid certificate of inspection, is not required to be inspected until 10 days after reentering this Commonwealth.

#### **175.8. Newly-Purchased Vehicles**

- (a) A vehicle which does not display a valid certificate of inspection at the time of sale, resale or entry into this Commonwealth shall be inspected within 10 days of sale, resale or entry into this Commonwealth, whichever occurs later. The inspection shall be coordinated with the staggered registration system regardless of the date of a previous inspection in this or another jurisdiction.

- (b) A vehicle which displays a valid certificate of inspection at the time of sale or resale may be driven until the inspection certificate expires.
- (c) Vehicles subject to semiannual inspection and mass transit vehicles are exempt from the provision of subsection (a) which requires coordination of inspection expiration with the staggered registration system.

**175.9. Vehicles Registered in Another State**

A vehicle registered in another state may be inspected. A certificate of inspection shall be issued only if the vehicle meets inspection requirements.

**175.10. Vehicles Requiring Emission Inspection Due to Address Change**

A subject vehicle required to participate in the Emission I/M Program because of vehicle registration change of address shall be phased into the emission inspection program at the time of the expiration of the current safety certificate of inspection.

**175.11. Coordination of Safety and Emission Inspection**

- (a) All subject vehicles required to participate in the Emission I/M Program shall display on the vehicle a renewed emission certificate of inspection prior to placement of a renewed safety certificate of inspection.
- (b) Upon successful completion of a safety inspection, a certificate of inspection may be affixed to the vehicle if the vehicle's emissions certificate of inspection is valid for more than 90 days from the date of the safety inspection.
- (c) If the emissions certificate of inspection will expire in less than 90 days from the date of the safety inspection, the vehicle shall receive a renewed emissions certificate of inspection prior to a renewed safety certificate of inspection being affixed.
- (d) A temporary inspection approval indicator may be used to designate vehicles which have successfully passed the required periodic safety inspection, but must display a renewed emission certificate of inspection, or obtain an official waiver, prior to placement of the renewed safety certificate of inspection.
- (e) Under this chapter, the expiring safety certificate of inspection may be replaced with a new safety certificate of inspection at any time prior to the expiration of the certificate of inspection to which the temporary inspection approval indicator is affixed. The temporary inspection approval indicator does not extend the inspection expiration of any certificate of inspection to which it is affixed.

## Subchapter B

# OFFICIAL INSPECTION STATION REQUIREMENTS

### 175.21. Appointment

- (a) **Authority** - For the purpose of establishing a system of official inspection stations, the Bureau will issue certificate of appointment to a privately owned facility within this Commonwealth that complies with the requirements of the Vehicle Code and this title. An official inspection station is authorized to inspect vehicles and issue official certificates of inspection. See 75 Pa.C.S. §4721 (relating to appointment of official inspection stations).
- (b) **Certificate of Appointment** - The certificate of appointment will be issued only when the Bureau is satisfied that the station is properly equipped and has certified personnel to make inspections and adjustments. Only those stations fulfilling Department requirements and complying with this chapter will be issued a certificate of appointment. Prior involvement with a suspended inspection station may be sufficient cause to deny appointment. The certificate of appointment at all times shall be conspicuously displayed at the place for which it is issued. See 75 Pa.C.S. §4722 (relating to certificate of appointment).
- (c) **Certificate Not Assignable** - A certificate of appointment shall be valid only for the person in whose name it is issued and for transaction of business at the place designated therein. A certificate of appointment shall not be assignable to another person or location.
- (d) **Valid Certificate Required** - No person shall in any manner represent a place as an official inspection station unless the station is operating under a valid certificate of appointment issued by the Bureau.
- (e) **Inspection Stations with Common Access** - No certificate of appointment may be issued for operation by an official safety inspection station on the premises of another official safety inspection station which utilizes the same access. This prohibition does not apply if the inspection stations have separate internal accesses, though sharing common external access.
- (f) **Suspended Inspection Stations** - No certificate of appointment shall be issued for operation of an official safety inspection station on the premises of an official safety inspection station which has been suspended, if the owner of the suspended station continues to conduct any type of business which utilizes the same access. This prohibition shall not apply if the station and the other business each have a separate internal access, though sharing a common external access.
- (g) **Cancellation of Appointments** - A certificate of appointment previously issued for a station which does not comply with the restrictions contained in subsection (e) or (f) will be cancelled April 28, 1983.

### 175.22. Making Application

- (a) **Form** - The applicant shall file one copy of Form MV-427, Application for Designation as an Official Inspection Station, with the Bureau. A separate application shall be made for each place of business.
- (b) **Bond or Proof of Insurance** - Requirements shall be as follows:
  - (1) An applicant for a certificate of appointment shall furnish a bond on a form prescribed by the Department or proof of insurance as required by 75 Pa.C.S. §4722 (c) (relating to certificate of appointment).
  - (2) The bond or insurance shall be in the amount of \$10,000 for each place of business and shall provide compensation to a vehicle owner for damage their vehicle may sustain while it is in possession of the inspection station.
  - (3) The bond or proof of insurance shall be renewed each year.
  - (4) Cancellation of the bond or insurance shall automatically void the certificate of appointment. Inspections shall cease until the Bureau receives a new bond or proof of insurance.
- (c) **Specification of Type** - The application shall indicate the type of inspection station authorization applied for; that is, Commonwealth, general, fleet, recreational and utility trailer, or motorcycle.
- (d) **Applicant** - The applicant shall be the owner of the business or, in the case of a corporation, some other person specifically authorized to sign the application.
  - (1) If a natural person, the applicant shall be 18 years of age or older.

- (2) If the applicant is a corporation, partnership or association, the application shall be signed by an officer, partner, associate or another person specifically authorized to sign the application.
  - (i) The person who signs the application shall be 18 years of age or older.
  - (ii) Except in the case of an executive officer, partner or associate, written evidence of the authority of the person—for example, station manager—to sign the application shall be attached thereto and attested to by a partner or a corporation or association officer.

### **175.23. Approval**

- (a) **Investigation** - An inspection station supervisor will conduct an investigation of each applicant to determine full compliance with the Vehicle Code and this chapter.
- (b) **English Comprehension** - The applicant and each inspection mechanic shall be sufficiently versed in the English language to read and understand this title.
- (c) **Issuance of Certificate** - Upon approval of the application by the Bureau, a certificate of appointment shall be issued to the applicant for the place of business located within this Commonwealth, as set forth in the application. No inspections shall be made unless a certificate of appointment has been issued to and is prominently displayed at the official inspection station.

### **175.24. Required Certificates and Station Signs**

After appointment, the owner of each inspection station shall prominently display all signs required by the Bureau, including the following:

- (1) A certificate of appointment for each type of station approved for the location.
- (2) A sign clearly stating the fee for the certificate of inspection separate from the fee for inspection. The fee for inspection shall be the same whether the vehicle passes or fails. The fee for inspection shall include the cost of labor for the inspection, including pulling wheels, but it shall not include the cost of parts, repairs or adjustments. The sign shall clearly indicate the fee for different types of vehicles—for example, passenger cars, trucks, and trailers—to the extent that the fee varies among vehicles. Fleet and Commonwealth stations are exempt from this requirement.
- (3) A current list of certified inspection mechanics, Form TS-443.
- (4) An official inspection station sign outside the garage, clearly visible to the public. This sign shall have a keystone design which is 24 inches high and 21 inches wide. The station number plate shall be 2 3/4 inches high and 13 3/8 inches wide. The background shall be navy blue with gold lettering. If hung from a bracket, the sign shall be double faced. A previously issued sign will still be permitted. Fleet and Commonwealth stations are exempted from this requirement.

### **175.25. Inspection Area**

- (a) **General** - The following requirements apply to inspection areas:
  - (1) Except as provided in subsection (b)(1)(iii) and (3), the inspection area shall be entirely within a sound, enclosed building, shall be in good repair; and shall be kept in good condition.
  - (2) Any anticipated alterations or change affecting the condition or size of the inspection area shall be reported to the inspection station supervisor at once.
  - (3) The floor shall be of a hard surface and in sound condition. Dirt floors will not be approved.
  - (4) The floor of the inspection area shall be level. No more than 1% slope from front to rear or side to side is acceptable.
  - (5) The inspection area shall be free from obstructions, including shelves, work benches, partitions, displays, machinery and stairways. If the inspection area or any part is located outside the building, the area shall also be kept clear of snow or other substances which would curtail or interfere with inspections.
  - (6) Hoists and lifts are permitted in the inspection area if a thorough and proper inspection can be performed.



## Subchapter B - Official Inspection Station Requirements

---

- (b) **Minimum Requirements** - The following minimum dimensions apply to inspection areas:
- (1) Commonwealth, fleet, and general inspection stations:
    - (i) Twelve feet wide by 22 feet long, if the station uses an approved headlight aimer or tester.
    - (ii) Twelve feet wide by 43 feet long, if the station uses an approved headlight aiming screen.
    - (iii) A motor carrier vehicle may be inspected either as single unit or in combination if, in the case of a station meeting the requirements of subparagraph (i), the inspection area has an additional unobstructed length of 42 feet or, in the case of a station meeting the requirements of subparagraph (ii), an additional unobstructed length of 21 feet.
  - (2) Motorcycle inspection stations:
    - (i) Ten feet wide by 18 feet long, if the station uses an approved headlight tester.
    - (ii) Ten feet wide by 32 feet long, if the station uses an approved headlight aiming screen.
  - (3) Trailer inspection stations: 12 feet wide by 55 feet long.
- (c) **Inspections Conducted in the Inspection Area** - An inspection shall be conducted entirely within the inspection area with the exception of the road test.

### 175.26. Tools and Equipment

- (a) **General Requirements** - An inspection station shall have tools and equipment in good operating condition sufficient to inspect each type of vehicle to be inspected, including all of the following:
- (1) Hammers - a ball-peen hammer, one plastic or brass hammer and one rubber hammer.
  - (2) A workbench.
  - (3) A portable light.
  - (4) Socket sets.
  - (5) Assorted open end and box end wrenches.
  - (6) Torque wrenches-foot-pound and inch-pound.
  - (7) Screw drivers-assorted.
  - (8) Pliers-assorted.
  - (9) Test light-continuity tester.
  - (10) Floor stands: four
  - (11) Floor jack or hoist-wheels shall spin freely.
  - (12) Tire pressure gauge.
  - (13) Brake drum gauges.
  - (14) Micrometer gauges or thickness gauges, with measurements in 1/1000 inch, capable of measuring both the range of rotor thickness and the depth of the scores.
  - (15) A ball joint gauge - not required for recreational, utility and motorcycle stations.
  - (16) A tread depth gauge capable of indicating amount of usable tire tread in increments of 1/32 inch.
  - (17) A brake-lining gauge capable of indicating the amount of usable lining on both riveted and bonded lining in increments of 1/32 inch.
  - (18) An approved headlight testing device - SAE approved No. J600a for photo-electric type and J602c for mechanic aimers. Not required for recreational and utility trailer stations.
  - (19) A paper punch with a minimum diameter or width of 1/4 inch and a maximum diameter or width of 3/8 inch.
- (b) **Discontinued testers** - An inspection station equipped with discontinued testers may continue to use them as long as they are in good working order and capable of testing all types of headlights.

**175.27. Hours**

- (a) An inspection station shall be open for business a minimum of 40 hours, Monday through Friday between 7 a.m. and 5 p.m. This section may be waived by the Bureau upon written request of the inspection station owner and prior approval of the inspection station supervisor. To be considered for a waiver of this section, the inspection station shall be open for business at least 10 business hours between 7 a.m. and 8 p.m. Monday through Friday. A request for a waiver of this section shall be submitted on a form provided by the Department. A waiver of this section may be denied or revoked for any of the following reasons:
- (1) A violation of this chapter was committed by the inspection station owner, manager, a certified inspection mechanic or other employee at the station within 3 years immediately preceding a request for a waiver.
  - (2) The station owner, manager, a certified inspection mechanic or other employee at an inspection station that has been granted a waiver of this section commits a violation of this chapter after the waiver has been granted.
  - (3) Station personnel currently employed or hired have been or are currently suspended for a violation of this chapter.
  - (4) The Department or a designee is unable, on 2 attempts on two different business days, to perform an official visit, including a periodic records audit, during the hours specified in the approved waiver.
  - (5) An inspection station fails to be in operation during the hours specified in the waiver.
  - (6) An inspection station fails to comply with this section.
- (b) This section does not apply to Commonwealth or fleet inspection stations.

**175.28. Certified Inspection Mechanics**

- (a) **General** - An official inspection station shall have at least one certified inspection mechanic. Every inspection shall be performed by a certified inspection mechanic. The mechanic shall only inspect the type of vehicle for which they are certified and for which they hold a valid driver's license, except as otherwise provided in 75 Pa.C.S. § 4726(a) (relating to certification of mechanics). The mechanic signing the inspection sticker shall conduct and be responsible for the entire inspection of the vehicle, including the road test, except that the Department may exempt a mechanic from the requirement to perform a road test because of a physical disability. See 75 Pa.C.S. § 4726.
- (b) **Multiple Stations** - A certified inspection mechanic may work part time at more than one official inspection station if the mechanic notifies the inspection station supervisor and the Vehicle Control Division of the names and station numbers of all current employers. Failure to do so may result in suspension of the mechanic's inspection privileges.
- (c) **Number of Inspections** - A certified mechanic may not inspect more than:
- (1) Two vehicles other than motorcycles per hour.
  - (2) Three motorcycles per hour.
- (d) **Certification Requirements** - A mechanic desiring to maintain certification or to become certified:
- (1) Shall be 18 years of age or older.
  - (2) Shall, as provided in subsection (a), have valid driver's license for each class of vehicle which the mechanic will inspect; except that a certified mechanic who inspects school buses is not required to hold a school bus driver endorsement. For the purposes of this chapter, a valid driver's license does not include a learner's permit, a probationary license held by a driver for less than 3 years, an occupational limited license or an interlock license. A mechanic exempted from the requirement to perform the road test shall also be exempt from the requirement of this paragraph.
  - (3) Shall have completed an approved certification course and successfully completed the required examination.
  - (4) Shall pass the required tactile test administered by a certified/qualified automotive instructor at an approved educational facility.

## Subchapter B - Official Inspection Station Requirements

---

- (e) **Recertification** - A mechanic shall be certified for no more than 5 years. Mechanics may renew their mechanic certification by passing the required examination within 180 days of receipt of notice from the Department that the mechanic card is due to expire.
- (f) **Prior Certification** - A mechanic card without an expiration date shall remain valid for 180 days after the date of notice to the mechanic to attend the certification course. Failure to complete the certification course and pass the required tests within 180 days will result in cancellation.
- (g) **Mechanic License Codes** - A mechanic will be issued codes from the following table for the types of vehicle inspections and equipment testing the mechanic is authorized to perform:

<b>Code</b>	<b>Authorized Inspection or Testing</b>
1	Inspection of passenger cars, trucks 17,000 pounds or less and trailers less than 10,000 pounds
2	Inspection of motorcycles
3	Inspection of trucks over 17,000 pounds, trailers over 10,000 pounds and buses
4	Inspection of all vehicles
5	Inspection under codes 1 and 2
6	Inspections under codes 2 and 3
7	Inspections under codes 1 and 3
9	Testing and calibration of electronic (nonradar) speed timing devices that measure elapsed time between two sensors
A	Testing and calibration of electronic (radar) speed timing devices
B	Testing and calibration of stopwatches
C	Testing and calibration of speedometers
D	Testing and calibration of electronic (nonradar) speed timing devices that calculate average speed between two points
J	Enhanced vehicle safety inspection in conjunction with inspection under existing mechanic license codes in this table for the purpose of authorizing the issuance of a branded Pennsylvania certificate of title

- (h) **Mechanic Card** - The valid mechanic card shall be carried by the mechanic when performing an inspection.
- (i) **Certified Document Reviewer** - The Department may certify nonmechanics to perform document review for the purpose of authorizing the issuance of a branded Pennsylvania certificate of title.

### 175.29. Obligations and Responsibilities of Stations

- (a) **Personal Liability** - It is the responsibility of the owner of an inspection station to do all of the following:
  - (1) To conduct the business of the official inspection station honestly and in the best interests of this Commonwealth, in accordance with the provisions of 75 Pa.C.S. (relating to Vehicle Code) and this chapter, and, except in the case of a fleet or Commonwealth inspection station, to make every reasonable effort to inspect all vehicles upon request.
  - (2) To make official inspection regulations and supplements available for the use of certified inspection mechanics and other employees involved in inspection.
  - (3) To notify the inspection station supervisor and the Vehicle Control Division when a certified mechanic is hired.
  - (4) To keep inspection records and required work orders available for examination and audit by the inspection station supervisor and other authorized persons.
  - (5) To keep certificate of inspection requisition forms for each inspection campaign.

- (6) To assume full responsibility, with or without actual knowledge, for:
  - (i) Every inspection conducted by an employe of the inspection station.
  - (ii) Every inspection conducted on the premises.
  - (iii) Every certificate of inspection issued to the inspection station.
  - (iv) Every certificate of inspection issued by the inspection station.
  - (v) A violation of the Vehicle Code or this chapter related to inspections committed by any employe of the inspection station.
- (7) To assure that each inspection is performed by an inspection mechanic certified to inspect that type of vehicle.
- (8) To have available, at all times, a current certificate of inspection for all types of vehicles inspected at that station.

**(b) Change of Ownership** - The following apply to change of ownership:

- (1) In the case of any change of ownership, the certificate of appointment, all unissued certificates of inspection, and all inspection material shall be surrendered immediately to the inspection station supervisor. The new owner shall submit a Form MV-427 application to the Bureau. An investigation of the premises will be conducted by the inspection station supervisor.
- (2) In the following circumstances, it shall not be necessary to surrender unissued certificates of inspection; however, no inspections shall be conducted until the new ownership has been approved and a new certificate of appointment issued:
  - (i) Creation, modification or termination of a partnership.
  - (ii) Incorporation of a business.
  - (iii) Transfer of the controlling interest in a corporation.
  - (iv) Transfer of ownership to a spouse, child or parent.

**(c) Change of Location** - In the case of a change of location of an inspection station, all of the following apply:

- (1) A Form MV-427 application shall be completed and submitted to the Bureau.
- (2) An investigation of the premises will be conducted by the inspection station supervisor.
- (3) Certificates of inspection will be audited by the inspection station supervisor and shall be retained by the station owner.
- (4) No inspections shall be made at the new location until it has been investigated and approved and a new certificate of appointment issued by the Bureau.
- (5) If the new location is not approved at the time of the investigation, the inspection station supervisor will pick up all current certificates of inspection and will retain them until the new location is approved.

**(d) Discontinuance of Business** - Inspections shall be discontinued in any of the following circumstances:

- (1) If the owner vacates, abandons or discontinues the inspection business. Immediate notice shall be provided to the Bureau and the inspection station supervisor. The inspection station supervisor will pick up the certificate of appointment and all certificates of inspection, records and other inspection materials and return them to the Bureau.
- (2) If the owner is deceased. If a member of the family or partner wishes to continue the business, a new application for appointment shall be submitted to the Bureau.
- (3) If the owner voluntarily discontinues the operation of an inspection station, the owner shall immediately notify the inspection station supervisor. Remaining inspection materials shall be returned to the inspection station supervisor.

**(e) Notice Required** - The following events shall be reported at once to the inspection station supervisor and the Bureau; however, it is not necessary to discontinue inspections:

- (1) Whenever certificates of inspection are damaged, lost or stolen.

## Subchapter B - Official Inspection Station Requirements

---

- (2) Whenever a certified mechanic or a person authorized to purchase certificates of inspection is dismissed or resigns.
  - (3) A change in the post office address of an inspection station, not location. The change shall be reported at once on Form MV-427.
  - (4) A change of the company name, not ownership. The change shall be reported at once on Form MV-427.
  - (5) When a person who signed the Form MV-427 application for a corporation is no longer in charge of the inspection station:
    - (i) A new Form MV-427 shall be submitted to the Bureau at once.
    - (ii) A new letter of authority is required for the person signing the Form MV-427.
  - (6) Whenever a person whose signature is on the signature card, Form MV-417, resigns or is relieved of inspection responsibilities, the owner shall request new signature cards from the Bureau at once. Upon receipt of new cards, the old cards shall be returned to the Bureau.
- (f) Customer Relations** - The garage owner shall consult the vehicle owner for permission to make repairs.
- (1) The permission may be established at the time the vehicle is brought to the station for inspection or after it is determined the repairs are needed.
  - (2) The vehicle owner shall be allowed to make their own repairs or to select anyone else they desire to do them for him.
  - (3) A part replaced as a result of inspection shall be retained until the vehicle is returned to the customer. The customer shall have the right to examine all replaced parts.
  - (4) The vehicle owner shall be informed in writing on the receipt or work order of any parts which, although in passing condition, the mechanic believes may become dangerous before the next inspection period. The brake and tire readings shall be indicated in writing on the receipt or work order. If a temporary inspection approval indicator is issued, the receipt or work order shall also contain the following information:
    - (i) A statement which specifies that failure to return the vehicle displaying a renewed emission certificate of inspection to the station prior to the expiration of the safety certificate of inspection shall void the temporary inspection approval indicator and necessitate a complete reinspection of the vehicle for which a fee may be charged.
    - (ii) A statement indicating that the fee for affixing a new certificate of inspection which shall be charged upon the return of the vehicle for the new certificate of inspection to be affixed. This fee shall be no greater than the posted fee for the certificate of inspection as required by Section 175.24(2) (relating to required certificates and station signs).

### 175.30. Commonwealth Inspection Stations

- (a) Eligibility** - This designation will be issued to stations owned and operated by:
- (1) The Federal Government.
  - (2) The Commonwealth.
  - (3) A political subdivision of the Commonwealth.
- (b) General Requirements** - An applicant for a Commonwealth inspection station shall meet the requirements of this chapter, unless specifically exempted, including the specific requirements for fleet stations.
- (c) Certified Inspection Mechanic** - Each official Commonwealth inspection station shall have at least one inspection mechanic certified to inspect each type of vehicle which will be inspected.
- (d) Method of Inspection** - A Commonwealth inspection station shall inspect and issue certificates of inspection only to vehicles registered in the name of the governmental body.
- (e) Certificates of Inspection** - No fee shall be charged for certificates of inspection requisitioned by Commonwealth inspection stations.

**175.31. Fleet Inspection Stations**

- (a) **Eligibility** - Eligibility requirements are as follows:
- (1) A fleet inspection station owner shall own or lease at least 15 or more vehicles.
  - (2) The certificate of appointment shall authorize inspection of only those vehicles registered or leased by the fleet inspection station owner. Privately owned or registered vehicles of company officers and employees may not be inspected at a fleet inspection station even if they are used for business purposes.
  - (3) The inspection certificate shall be cancelled if the number of vehicles owned or leased falls below 15, except for a temporary delay in ordering or receiving additional vehicles to supplement the fleet.
- (b) **Certified Inspection Mechanic** - Each fleet inspection station shall have at least one inspection mechanic certified to inspect each type of vehicle which will be inspected.
- (c) **Requirements** - Requirements shall include the following:
- (1) An applicant for a fleet inspection station shall meet the requirements of this chapter, unless specifically exempted.
  - (2) In addition to the minimum inspection area requirements of §175.25 (b)(1)(i) (relating to inspection area), the inspection area shall be large enough to accommodate the largest vehicle to be inspected at the fleet inspection station.

**175.32. Recreational and Utility Trailer Inspection Stations**

- (a) **Eligibility** - This designation will be issued to stations that inspect trailers.
- (b) **Requirements** - An applicant for a trailer station shall meet the requirements of this chapter, unless specifically exempted.
- (c) **Certified Inspection Mechanic** - Each trailer inspection station shall have a mechanic certified to inspect trailers present during normal business hours.
- (d) **Record Sheets** - Inspections of trailers shall be recorded on Form MV-480. Inspection of recreational trailers shall be recorded on separate Form MV-480 report sheets.
- (e) **Tools** - In addition to the tool requirements of §175.26 (relating to tools and equipment), trailer stations shall have an ammeter—low range type.

**175.33. Motorcycle Inspection Stations**

- (a) **Eligibility** - This designation shall be issued to stations that inspect only motorcycles.
- (b) **General Requirements** - A motorcycle inspection station shall meet all requirements of this chapter, unless specifically exempted.
- (c) **Certified Inspection Mechanic** - A motorcycle inspection station shall have a mechanic certified to inspect motorcycles present during normal business hours.
- (d) **Record Sheets** - A motorcycle inspection shall be recorded on Form MV-480.
- (e) **Tools** - In addition to the tool requirements of §175.26 (relating to tools and equipment), a motorcycle station shall have the following additional tools:
- (1) A spoke wrench.
  - (2) A truing stand.
  - (3) A photo-electric type aimer or approved headlight aiming screen.
- (f) **Exemption** - A motorcycle station is not required to have floor jacks or a floor stand.

**175.34. General Inspection Stations**

- (a) **Eligibility** - This designation will be issued to stations that inspect all vehicles if the station is so equipped.

## Subchapter B - Official Inspection Station Requirements

---

- (b) **General Requirements** - An applicant for a general inspection station shall meet the requirements of this chapter, unless specifically exempted.
- (c) **Certified Inspection Mechanic** - A vehicle general inspection station shall have a certified mechanic present during normal business hours.
- (d) **Method of Inspection** - A vehicle shall be inspected according to this chapter by a mechanic certified to inspect the appropriate class of vehicle.

### 175.35. Enhanced Vehicle Safety Inspection Stations

- (a) **Eligibility** - The enhanced vehicle safety inspection designation will be issued to stations that perform enhanced vehicle safety inspections for the purpose of titling reconstructed, specially constructed, recovered theft, flood, collectible, modified vehicles, street rods and other vehicles requiring a branded certificate of title as prescribed by the Department.
- (b) **General requirements** - In addition to contractual requirements prescribed by the Department, an applicant for an enhanced vehicle safety inspection station shall meet the requirements of this chapter unless specifically exempted.
- (c) **Certified enhanced inspection mechanic** - Each enhanced vehicle safety inspection station shall have a certified enhanced inspection mechanic authorized by the Department employed and present during normal business hours.
- (d) **Certified document reviewer** - An enhanced vehicle safety inspection station shall have a certified document reviewer authorized by the Department employed and present during normal business hours. The certified enhanced inspection mechanic may act as the certified document reviewer.
- (e) **Method of inspection** - A subject vehicle shall undergo an enhanced vehicle safety inspection according to this chapter by a mechanic certified to perform enhanced inspections on the appropriate class of vehicle.
- (f) **Tools** - In addition to the tool requirements of § 175.26 (relating to tools and equipment), enhanced vehicle safety inspection stations shall have additional tools and equipment as contractually required by the Department.

## Subchapter C

### CERTIFICATE OF INSPECTION

#### 175.41. Procedure

- (a) **Unauthorized Display of Certificate of Inspection** - No certificate of inspection or temporary inspection approval indicator may be marked or affixed to a vehicle unless the vehicle has successfully passed inspection, meeting the requirements of 75 Pa.C.S. (relating to the Vehicle Code) and this chapter.
- (b) **Type** - A certificate of inspection shall be selected for the particular type of vehicle being inspected according to this chapter. The certificate of inspection shall be examined before using. If found to be incorrect, the inspection station supervisor and the Vehicle Inspection Division shall immediately be notified.
- (1) TS-460 shall be used for motor vehicles except motorcycles and motor-driven cycles.
  - (2) TS-463 shall be used for all trailers, motorcycles and motor-driven cycles.
  - (3) A temporary inspection approval indicator shall be used to designate a vehicle which has successfully passed the required periodic safety inspection, but which shall display a renewed emission certificate of inspection before a new safety certificate of inspection sticker may be affixed to the vehicle.
- (c) **Required Information** - The information on the rear of the certificate of inspection shall be completed in its entirety in permanent ink. The odometer reading is not required to be completed for trailers and motorcycles.
- (1) The temporary inspection approval indicator shall be affixed as described in subsection (e)(5) so as to be visible to the vehicle operator (while seated in the driver's location) without obscuring any required information entered on the back of the safety certificate of inspection.
  - (2) When replacing a certificate of inspection for which a temporary inspection approval indicator has been issued, the back of the new certificate of inspection shall be completed using the information recorded at the time of the original inspection.
- (d) **Affixing Certificate of Inspection or Temporary Inspection Approval Indicator** - The certificate of inspection or temporary inspection approval indicator shall only be affixed to the vehicle immediately upon the successful completion of the inspection, on the premises of the official inspection station and on a portion of the premises located within 100 feet and on the same side of the street as the official inspection station. A certificate of inspection or temporary approval indicator may not be issued or affixed at another area or location.
- (1) It is the responsibility of the certified inspection mechanic who performed the inspection to affix the certificate of inspection or temporary inspection approval indicator to the vehicle in the location prescribed by the Department. The certificate of inspection or temporary inspection approval indicator shall be affixed only after completion of the entire inspection, including the road test. A mechanic exempted by the Department from performing the road test under this chapter is responsible for affixing the certificate of inspection or temporary inspection approval indicator.
    - (i) Inspection stations may not replace a certificate of inspection to which a temporary inspection approval indicator has been affixed if one or more of the following apply:
      - (A) The inspection station did not perform the original inspection of the vehicle or issue the temporary inspection approval indicator affixed to the current certificate of inspection.
      - (B) The vehicle does not display a renewed emission certificate of inspection.
      - (C) The original safety certificate of inspection has expired.
      - (D) The vehicle is in an obviously unsafe condition, including, but not limited to, bald tires, exhaust leaks, broken glazing and broken or missing lighting.
    - (ii) Inspection stations may charge the posted fee for inspection of a vehicle to which a temporary inspection approval indicator has been affixed. A fee may not be charged for the temporary inspection approval indicator. The posted fee for the new certificate of inspection may only be charged when the new safety certificate of inspection is affixed to the vehicle.



## Subchapter C - Certificate of Inspection

---

- (2) The surface on which the sticker is to be attached shall be wiped dry and clean of road film, grease and moisture for proper adhesion. The following apply:
  - (i) The glass or body surface shall be cleaned thoroughly.
  - (ii) The protective slip sheet shall be removed from the adhesive side of the certificate of inspection or temporary inspection approval indicator.
  - (iii) The sticker shall be positioned carefully, then squeezed until it is tightly affixed to the windshield, body or existing certificate of inspection.
  - (iv) Only the current certificate of inspection shall be visible.

**(e) Certificate of Inspection Location** - The certificate shall be located as follows:

- (1) On a motor vehicle, the certificate of inspection shall be affixed in an upright position, to the extreme lower left-hand inside corner of the windshield—driver’s side.
- (2) On a motorcycle or a motor-driven cycle, the certificate of inspection shall be affixed in a clearly visible, upright position to one of the following areas of the vehicle:
  - (i) On the left side—traffic side—of the front fork.
  - (ii) On the left side—traffic side—of the front fender.
  - (iii) On a plate attached by weld or rivets to the left side—traffic side—of the vehicle for purposes of mounting the certificate of inspection.
- (3) The new certificate of inspection may not be placed over the old certificate of inspection. The certificate of inspection which expired or is about to expire shall be removed prior to placement of the new certificate of inspection.
- (4) On trailers, the certificate of inspection shall be affixed, in an upright position, to the left front—traffic side—of the trailer, approximately 6 feet high, if possible. The certificate may not be placed on the nose or front side of the trailer. A holder is permitted if it is in the proper location and the certificate of inspection is affixed to prevent theft or transfer to another vehicle. The new certificate of inspection may not be placed over the old certificate of inspection.
- (5) The temporary inspection approval indicator shall be affixed to the top left portion of the reverse side of the existing safety certificate of inspection so as to be visible to the vehicle operator (while seated in the driver’s location) without obscuring any required information entered on the back of the safety certificate of inspection.

**(f) Inspection Cycles** - When selecting the proper type of certificate insert, the new expiration date is based upon whether the inspection is an annual or semiannual inspection.

- (1) An annually inspected vehicle will receive an inspection for 1 year from the expiration of the safety inspection sticker which is about to expire, except motorcycles, which receive an expiration in accordance with charts provided by the Department. A sticker may not be issued for more than 15 months from the month of inspection. If a vehicle, other than a motorcycle, does not display a currently valid certificate of inspection, the vehicle shall receive an inspection valid for 1 year from the month of inspection.
- (2) A semiannually inspected vehicle will receive an inspection for no more than 9 months based on charts supplied by the Department.
- (3) Insert stickers will be selected based upon the expiration date on the new inspection. If the vehicle is subject to emission inspection as determined by an I/M indicator on the registration card, the vehicle will receive an I/M indicator tab on the safety certificate of inspection.
- (4) A temporary inspection approval indicator shall be used to indicate that a vehicle has successfully passed the required periodic safety inspection, but shall display a renewed emission certificate of inspection before a new safety certificate of inspection sticker may be affixed to the vehicle. The temporary inspection approval indicator does not extend the expiration of any certificate of inspection to which it is affixed.

**175.42. Recording Inspection**

- (a) **Fraudulent Recording** - Fraudulent recording of an inspection will be considered cause for suspension of inspection privileges.
- (b) **Signature** - The certified mechanic who performed the entire inspection shall place their signature in accordance with the following recordkeeping requirements:
- (1) At stations utilizing Form MV-431 or MV-480, the certified mechanic who performed the entire inspection shall place their signature in the appropriate column of Form MV-431 or MV-480 immediately following the inspection. Both the mechanic exempted from Performing the road test under this chapter and the certified mechanic who performed the road test shall place their signatures in the appropriate column.
    - (i) When the inspection information is transferred from a work order to the Form MV-431 or MV-480 by anyone other than the certified mechanic who performed the inspection, the work order shall contain the certified mechanic's signature and be retained for audit.
    - (ii) The person who enters the information shall place the name of the certified mechanic in the appropriate column and the initials of the person putting the information on the form in the appropriate column.
    - (iii) A mechanic exempted from performing the road test under this chapter and the certified mechanic who performed the road test shall sign the work order.
    - (iv) The person who transfers the information shall place the names of both certified mechanics in the appropriate column.
  - (2) At stations utilizing an electronic data collection and storage program, the certified mechanic who performed the entire inspection shall place their signature on the work order immediately following the inspection. Both the mechanic exempted from performing the road test under this chapter and the certified mechanic who performed the road test shall place their signatures on the work order. Work orders shall be retained for audit.
- (c) **Records Retention** -
- (1) The original official inspection report sheet (Form MV-431 or MV-480) shall be retained as a garage record and kept on file at the station for audit. At the close of each inspection period, the official inspection report sheet shall be placed in the station's files, even though all spaces may not have been used, and a new inspection report sheet shall be started for the new inspection period.
  - (2) A work order signed by the inspecting mechanic as required under this section shall be available for inspection upon request by the inspection station supervisor or an authorized representative of the Department.
- (d) **Content** -
- (1) **Stations utilizing Form MV-431 or MV-480.** The paper inspection report sheet (Form MV-431 for passenger cars, trucks and buses or MV-480 for motorcycles and trailers) shall be neat and legible and completed in its entirety. Details pertinent to every vehicle inspected, including rejections, shall be recorded on the report sheet at the time of inspection. Items inspected, adjusted or repaired shall be recorded. If the report sheet lists a piece of equipment which does not apply to the specific type of vehicle being inspected, a dash shall be placed in the column to indicate it has not been overlooked or neglected. Certificates of inspection issued shall be listed in numeric order.
    - (i) Temporary inspection approval indicators, if issued in lieu of a certificate of inspection, shall be recorded on a separate report sheet (Form MV-431) and shall be indicated in the area designated for the sticker number. This separate report sheet shall be completed as described in this subsection except a "T" shall be entered in the area designated for the sticker number to indicate that a temporary inspection approval indicator was issued. An inspection station may not impose a sticker charge for the issuance of a temporary inspection approval indicator.
    - (ii) Upon the return of a vehicle for which a temporary inspection approval indicator has been issued, the station which originally affixed the temporary inspection approval indicator shall:

## Subchapter C - Certificate of Inspection

---

- (A) Verify the year, make, body style, VIN and proof of financial responsibility for the vehicle presented for a renewed certificate of inspection to ensure it is the same vehicle indicated on the report sheet (Form MV-431) when the original inspection was performed. This information shall be recorded as a new entry on the regular report sheet (Form MV-431) where all inspection sticker serial numbers issued are recorded.
  - (B) Record, on the Form MV-431, the serial number of the new certificate of inspection to be affixed to the vehicle along with the vehicle owner's name, address, VIN, license plate number, vehicle year, make and body style. A reference to the date and number of the original inspection performed shall be noted in the shaded area to the left of the area designated for the sticker serial number and total cost (that is, See T- inspection number 123 dated 01/01/97).
  - (C) Enter, in the appropriate area of the report sheet (Form MV-431), the name of the certified inspection mechanic that verified the original inspection information and that is replacing the certificate of inspection.
- (2) **Stations utilizing an electronic data collection and storage program.** The inspection record shall be completed in its entirety. Details pertinent to every vehicle inspected, including rejections, shall be recorded at the time of inspection. Items inspected, adjusted or repaired shall be recorded. If the inspection record lists a piece of equipment which does not apply to the specific type of vehicle being inspected, it shall be designated in the inspection record as "N/A" to indicate it has not been overlooked or neglected.
- (i) For those vehicles which pass the safety inspection but do not yet display a renewed emission certificate of inspection as required, stations shall record a pending or incomplete safety inspection without issuing a safety certificate of inspection.
  - (ii) The temporary inspection approval indicator shall be affixed as described in § 175.41 (relating to procedure). Upon the return of a vehicle for which a temporary inspection approval indicator has been issued, the station which originally affixed the temporary inspection approval indicator shall:
    - (A) Verify the year, make, body style, VIN and proof of financial responsibility for the vehicle presented for a renewed certificate of inspection to ensure it is the same vehicle indicated on the inspector record when the original inspection was performed.
    - (B) Record, on the pending inspection record, the serial number of the new certificate of inspection to be affixed to the vehicle.
    - (C) If the name of the certified inspection mechanic that verified the original inspection information and that is replacing the certificate of inspection is someone other than the certified inspection mechanic who performed the original inspection, they shall also sign the work order.
- (3) **Replacing a certificate of inspection.** The certified inspection mechanic replacing the certificate of inspection shall sign the back of the new certificate of inspection and record the information from the original inspection entry (wheels pulled, date of inspection, and the like) on the new certificate of inspection before it is affixed to the vehicle.
- (4) **Prohibitions against replacing a certificate of inspection.** Inspection stations may not replace a certificate of inspection to which a temporary inspection approval indicator has been affixed if one or more of the following apply:
- (i) The inspection station did not perform the original inspection of the vehicle or issue the temporary inspection approval indicator affixed to the current certificate of inspection.
  - (ii) The vehicle does not display a renewed emission certificate of inspection.
  - (iii) The original safety certificate of inspection has expired.
  - (iv) The vehicle is in an obviously unsafe condition, including, but not limited to, bald tires, exhaust leaks, broken glazing, and broken or missing lighting.
- (e) **Nonrelated Items** - Gas oil, or other non- related items shall not be included in the total charges for repair and inspection.

- (f) **Classifications** - The form numbers listed in this subsection explain the general classification of vehicles to be recorded on each type of inspection record:
- (1) **Form MV-431.** Motor vehicles except motorcycles and motor-driven cycles shall be recorded on this form.
  - (2) **Form MV-480.** Trailer, motorcycle, and motor-driven cycles shall be recorded on this form.

### 175.43. Security

- (a) **Check for Errors** - When inspection stickers are received by the inspection station, they should be checked for errors. If errors are discovered, they shall be reported to the Vehicle Control Division at once.
- (b) **Not Transferable** - An inspection certificate is not transferable. It shall only be affixed to vehicles as designated on the inspection record sheet of the inspection station to which the certificates were issued.
- (c) **Removal** - Except as provided in paragraphs (1) and (3), a certificate of inspection may not be removed from a vehicle for which the certificate was issued, except to replace it with a new certificate of inspection issued under this chapter and Chapter 177 (relating to emission inspection program).
- (1) A person replacing or repairing a windshield in a manner that requires removal of a certificate of inspection shall, at the option of the registrant of the vehicle, cut out the portion of the windshield containing the certificate of inspection and deliver it to the registrant of the vehicle or destroy the certificate. The vehicle may be driven up to 5 days if it displays the portion of the old windshield containing the certificate. Within the 5-day period, an official inspection station may affix to the vehicle another certificate of inspection for the same period without reinspecting the vehicle, in exchange for the portion of the old windshield containing the certificate of inspection. Example: A #1 certificate of inspection shall be replaced with a #1 certificate of inspection. The replacement may be made any time prior to the expiration of the certificate of inspection. A fee of no more than \$2 plus the fee paid to the Department for the certificate may be charged for exchanging the certificate of inspection.
    - (i) A replacement certificate of inspection may not be issued in the following circumstances:
      - (A) Acceptable proof of financial responsibility is not provided. For the purpose of this chapter, financial responsibility shall be proven by one of the following documents:
        - (I) A valid financial responsibility identification card issued in accordance with 31 Pa. Code (relating to insurance).
        - (II) The declaration page of a valid insurance policy.
        - (III) A valid self-insurance identification card.
        - (IV) A valid binder of insurance issued by an insurance company licensed to sell motor vehicle liability insurance in this Commonwealth.
        - (V) A valid insurance policy issued by an insurance company licensed to sell motor vehicle liability insurance in this Commonwealth.
      - (B) The vehicle is in an obviously unsafe operating condition.
    - (ii) The portion of the windshield containing the certificate of inspection shall be retained for audit by the inspection station supervisor.
    - (iii) Record all information from the old certificate of inspection on Form MV-431. The replacement certificate of inspection shall be recorded on the same Form MV-431 and marked "replacement sticker issued." Stations utilizing an electronic data collection and storage program shall use the appropriate replacement sticker function menu to record replacements.
    - (iv) "Replacement" shall be marked on the reverse side of the replacement certificate of inspection.
  - (2) Only one current, valid certificate of inspection shall be visible on a vehicle. The old certificate of inspection shall be removed and completely destroyed before a new sticker may be affixed.
  - (3) A vehicle that has an expired emission certificate of inspection affixed and which no longer has an I/M Registration Indicator on the registration card, shall have the expired emission sticker removed by the safety inspection mechanic who is affixing a new safety certificate of inspection.

## Subchapter C - Certificate of Inspection

---

- (d) **Security** - Inspection certificates and temporary inspection approval indicators shall be kept under lock and key in a safe place. The station owner shall be solely responsible for their safety and shall account for certificates of inspection and temporary inspection approval indicators issued to the station.
- (e) **Unused** - Unused certificates of inspection for an expired period shall be retained by the inspection station until audited by the inspection station supervisor. The Department will refund 75% of the purchase price of the unused certificates of inspection after the audit has been completed.
- (f) **Issuance of Certificates of Inspection** - Certificates of inspection will not be issued by the Bureau to anyone who is not listed as an authorized purchaser on Form MV-500 on file with the Bureau. The inspection station owner or manager shall accept full responsibility for certificates of inspection delivered to authorized purchasers listed on Form MV-500.
- (g) **Authorized Purchasers** - A new MV-500 to authorize persons to purchase certificates of inspection shall be ordered from the Vehicle Inspection Division immediately whenever an employee whose signature appears on the form is no longer employed by the station or a signature is to be added or deleted.

### 175.44. Ordering Certificates of Inspection

- (a) **Forms** - The following requisition forms shall be used to order certificates of inspection and inserts:
  - (1) MV-436A - For vehicles.
  - (2) MV-467A - For inserts and temporary inspection approval indicators.
- (b) **Contents** - Required information shall be entered on the order form.
  - (1) The correct name, address and station number, as shown on the certificate of appointment, shall be entered on every requisition form.
  - (2) A requisition shall be personally signed by one of the persons whose signature appears on Form MV-500. The signature shall be identical to the one on file or the requisition will be rejected. No one may order certificates of inspection unless their signature is on Form MV-500 on file with the Department.
- (c) **Additional Instructions** - The following also apply:
  - (1) When special delivery is desired, a separate check shall be enclosed for postage. Do not enclose cash or add the amount for postage to the check for certificates of inspection.
  - (2) Each sticker requisition shall be accompanied by a separate check. Certificates of inspection may be ordered on one requisition form. Checks shall be made payable to the "Department of Transportation" or "PennDOT."
  - (3) Requisitions may be snap-out forms with two sheets in each set. All copies shall be forwarded to the Department. No copy may be detached.
  - (4) An incomplete or improper certificate of inspection requisition or check shall be returned to the official inspection station for correction. To avoid unnecessary inconvenience or delay, information shall be rechecked carefully.
  - (5) If certificates of inspection are to be delivered to a mailing address instead of the inspection station address, the mailing address shall be included on every requisition submitted to the Department.
- (d) **Copies** - A copy of the requisition or a Department receipt will be returned with the order of certificates of inspection shipped from the Department. Station copies of all requisitions or Department receipts shall be kept on file at the station for 2 years and shall be made available for inspection upon request of the inspection station supervisor or an authorized representative of the Department.
- (e) **Suggested Schedule** - Certificates of inspection should be ordered as needed. Thirty days should be allowed for delivery.
- (f) **Additional Certificates** - An inspection station should anticipate its need for additional certificates of inspection.

**175.45. Violation of Use of Certificate of Inspection**

A person may not do any of the following:

- (1) Make, issue, transfer or possess an imitation or counterfeit of an official certificate of inspection or temporary inspection approval indicator and shall be sanctioned consistent with 75 Pa.C.S. §4730(c) (relating to penalty).
- (2) Display or cause to be displayed on a vehicle or have in their possession a certificate of inspection or temporary inspection approval indicator knowing it is fictitious, stolen, issued for another vehicle or issued without an inspection having been made and shall be sanctioned consistent with the provisions of 75 Pa.C.S. §4730(c) (relating to penalty).
- (3) Furnish, loan, give or sell certificates of inspection and approval to other official inspection station or other person except upon an inspection made in accordance with this chapter. See 75 Pa.C.S. §4730(b).

## Subchapter D

### SCHEDULE OF PENALTIES AND SUSPENSION: Official Inspection Stations and Certified Mechanics

#### 175.51. Cause for Suspension

- (a) **Schedule** - The complete operation of an official inspection station is the responsibility of the owner. Failure to comply with the appropriate provisions of 75 Pa.C.S. (relating to Vehicle Code) will be considered sufficient cause for suspension of inspection privileges. A violator is also subject to criminal prosecution.

TYPE OF VIOLATION	DURATION OF SUSPENSION		
	1st Violation	2nd Violation	3rd and Subsequent Violation
<b>(1) CATEGORY 1</b>			
(i) Issuance or possession of altered, forged, stolen or counterfeit certification of inspection	1 year	Permanent	
(ii) Furnish, lend, give, sell or receive a certificate of inspection without inspection	1 year	Permanent	
(iii) Faulty inspecting of equipment or parts	2 months	1 year	3 years
<b>(2) CATEGORY 2</b>			
(i) Fraudulent record keeping	1 year	Permanent	
(ii) Improper record keeping	2 months	1 year	3 years
(iii) Failure to verify registration, title, manufacturer's statement of origin, financial responsibility information, or inspecting a vehicle with an expired registration or when valid proof of financial responsibility has not been submitted	2 months	4 months	1 year
(iv) Failure to affix certificate of inspection immediately upon successful completion of the inspection	2 months	4 months	1 year
(v) Improperly assigning certificate of inspection	2 months	4 months	1 year
(vi) Failure to produce records, certificates of inspection, signature cards, certificate of appointment, or mechanic card upon demand by inspection station supervisor or authorized representative of the Department	2 months until produced	6 months or until produced	1 year or until produced
(vii) Improper certificate of inspection security	Warning	4 months	1 year
(viii) Careless record keeping	Warning	4 months	6 months

TYPE OF VIOLATION	DURATION OF SUSPENSION		
	1st Violation	2nd Violation	3rd and Subsequent Violation
<b>(3) CATEGORY 3</b>			
(i) Inspection by mechanic with suspended, revoked, cancelled or recalled operating privilege	2 months	6 months	1 year
(ii) Inspecting more than three motorcycles or two other vehicles per hour	4 months	6 months	1 year
(iii) Inspection by uncertified mechanic	4 months	6 months	1 year
<b>(4) CATEGORY 4</b>			
(i) Misstatement of fact	2 months	4 months	1 year
(ii) Performing or indicating unnecessary repairs for the purpose of passing an inspection	4 months	6 months	1 year
(iii) Performing repairs for the purpose of passing an inspection without vehicle owner authorization	4 months	6 months	1 year
(iv) Unclean inspection area	2 months	4 months	6 months
(v) Required tools or equipment missing or broken	Warning if tools are repaired or replaced; if not, suspension until tools are repaired or replaced	2 months or until tools are repaired, whichever is greater.	6 months or until tools are repaired or replaced, whichever is greater
(vi) Bad check	Warning if amount due is paid within 10 days from date notified. If not, suspension until amount due is paid.	2 months or until amount due is paid, whichever is greater	6 months or until amount due is paid, whichever is greater
(vii) Failure to report discontinuance of business	1 year	3 years	Permanent
(viii) Failure to notify the Department of changes of ownership, location or other changes affecting an official inspection station	4 months	6 months	1 year
(ix) Failure to give a written receipt or work order to customer, or to list required information on work order	2 months	4 months	1 year
(x) Failure to satisfy monetary penalties for violations of Chapter 177 (relating to emission inspection program) within 90 days of notification	Suspension until amount due is paid	2 months or until amount due is paid, whichever is greater	6 months or until amount due is paid, whichever is greater



## Subchapter D - Schedule of Penalties and Suspension

---

- (b) **Assignment of points** - The Department will permit the station owner to consent to the acceptance of a point assessment for the station in lieu of suspension, if the station owner, manager, supervisor or other management level employe was without knowledge of the violation, and should not have known of the violation.
- (1) The station owner bears the burden of proving that it provided proper supervision of the employe who committed the violation, but that supervision could not have prevented the violation.
  - (2) By accepting the assessment of points the station owner waives the right to appeal the Department's determination in the case to a court of record. If the station owner refuses to accept the point assessment, the Department shall issue the suspension indicated in this subchapter.
- (c) **Point Determination** - When offering a point assessment, in lieu of a suspension, the Department will calculate points in the following manner:
- (1) One point will be assessed for every 2 months of suspension which the Department would otherwise impose.
  - (2) A point assessment will not exceed eight points for a single violation.
  - (3) If an inspection station is currently serving a suspension for a violation of this chapter, no point assessment will be made. A subsequent violation which occurs while a current suspension is being served will result in a suspension that will run consecutively with the current suspension.
- (d) **Point Suspension** - The Department will suspend the privileges of an official inspection station for an accumulation of points whenever the station accumulates ten or more points.
- (1) The first occurrence of an accumulation of ten points or more shall result in a suspension for a period of 2 months for each point over nine points; the second occurrence of an accumulation of ten points or more shall result in a suspension for a period of 4 months for each point over nine points; the third occurrence of an accumulation of ten points or more shall result in a suspension for a period of 6 months for each point over nine points.
  - (2) The fourth occurrence for an accumulation of ten or more points shall result in a permanent suspension.
  - (3) Only suspensions issued as the result of an accumulation of points shall be counted in determining whether a suspension for point accumulation is a second, third or fourth suspension.
  - (4) If the point record of a station has been reduced to zero, any subsequent accumulation of points that will result in the suspension of the station will be considered first, second, third and fourth suspensions.
- (e) **Restoration of Suspensions** - Stations and mechanics that have had their privilege to inspect suspended shall be restored as follows:
- (1) A station that has been suspended as a result of a point accumulation shall have its point total reduced to six points upon restoration.
  - (2) Additional points assessed against the station since the last violation resulting in a suspension will be added to the point record unless the station has served an additional suspension under subsection (c)(3).
  - (3) A certified inspection mechanic that has been suspended under this chapter will be restored at the termination of the suspension.
  - (4) Prior to restoration, the station shall meet the reapplication requirements of section §175.52 (relating to reapplication) to ensure timely restoration.
- (f) **Removal of Points** - Points assessed against a station shall be removed at the rate of two points for each 12 consecutive months in which the station has not had additional violations charged against it that could result in additional points. The 12-month period starts at the date of the last violation resulting in points or from the date of restoration of a suspension resulting from an accumulation of points, whichever occurred last.
- (g) **Subsequent Violations** - Determination of second and subsequent violations is made on the basis of previous violations in the same category within a 3-year period.
- (h) **Multiple Violations** - In the case of multiple violations which are reviewed and considered at one Departmental hearing, the Department will impose separate penalties for each violation as required by the schedule. The Department may direct that a suspension be served concurrently. If the Department permits a

station to accept points in lieu of a suspension, the points will be assigned for the more serious violation affecting each vehicle. Violations affecting more than one vehicle will be treated as separate violations.

- (i) **Sale of Business** - An inspection station may be sold, transferred or leased to a new owner, and an application for appointment will be considered while the station is suspended or restored pending an appeal unless sold, transferred or leased to a person affiliated with the station or related to the station owner.
- (j) **Confiscated Materials** - Certificates of inspection and records confiscated as the result of an investigation will be retained by the inspection station supervisor. Certificates of inspection, certificate of appointment, mechanic certification cards and records confiscated as the result of a suspension will be returned to the Department. The Department will refund 75% of the purchase price for certificates of inspection confiscated as the result of a suspension.
- (k) **Official Documents** - Whenever an inspection station or mechanic is suspended or cancelled, the Department may order the surrender, upon demand, to any Inspection Station Supervisor or authorized representative of the Department of any of the following items:
  - (1) Inspection records.
  - (2) A certificate of appointment.
  - (3) Signature cards.
  - (4) Unused certificates of inspection.
  - (5) Unused monthly insert tabs.
  - (6) A mechanic certification card.

### **175.52. Reapplication**

After a suspension has been served, inspection privileges will not be restored until an application for reappointment has been received by the Department. Upon receipt of an application for reappointment following suspension of 3 months or more, a complete and thorough investigation by the inspection station supervisor will be conducted to determine if applicant qualifies for reappointment under Subchapter B (relating to official inspection stations). Other applications for reappointment are subject to investigation at the discretion of the Department. The station shall submit an application for appointment 30 days prior to the restoration date to ensure timely restoration.

## Subchapter E

### PASSENGER CARS AND LIGHT TRUCKS

#### 175.61. Application of Subchapter

Equipment standards set forth in this subchapter apply to passenger cars and light trucks driven on highways.

#### 175.62. Suspension

Every suspension component shall be in safe operating condition as described in §175.80 (relation to inspection procedure).

#### 175.63. Steering

- (a) **Condition of Steering Components** - The steering assembly and steering mechanism shall be in safe operating condition as described in §175.80 (relating to inspection procedure).
- (b) **Steering Wheel** - The steering wheel, except if specially designed for handicapped drivers, shall be equivalent to original equipment in material strength and have minimum outside diameter of 13 inches.

#### 175.64. Braking Systems

- (a) **Condition of Braking Systems** - Braking systems and components shall be in safe operating condition as described in §175.80 (relating to inspection procedure).
- (b) **Service Brakes** - A vehicle specified under this subchapter shall be equipped with a service brake system. See 75 Pa.C.S. §4502 (relating to general requirements for braking systems).
  - (1) The service brakes shall act on all wheels upon application and shall be capable of stopping a vehicle in not more than the maximum stopping distance prescribed in Table I (relating to brake performance), except on a vehicle being transported in driveaway-towaway operation.
  - (2) The brake lining and brake fluids shall be of type approved by the vehicle manufacturer or shall meet the Society of Automotive Engineers (SAE) standards Appendix A (relating to minimum requirements for motor vehicle brake lining - SAE J998).
  - (3) A passenger car manufactured or assembled after June 30, 1967, and designated as a 1968 or later model shall be equipped with a service brake system of a design that rupture or failure of either the front or rear brake system will not result in the complete loss of braking function. Braking function may be obtained by hydraulic or other means through a normal brake mechanism. In the event of a rupture or failure of actuating force component, the unaffected brakes shall be capable of applying adequate braking force to vehicle.
  - (4) Metal from a shoe may not contact the brake drums or rotors.
  - (5) Brake lines shall be approved for use as brake lines.
- (c) **Parking Brake System** - A vehicle specified under this subchapter shall be equipped with a parking brake system. See 75 Pa.C.S. §4502.
  - (1) A parking brake system shall be adequate to hold the vehicle on a surface free from ice or snow on a 20% grade with vehicle in neutral.
  - (2) The parking brakes shall be separately actuated so that failure of any part of the service brake actuation system will not diminish the vehicle's parking brake holding capability.

#### 175.65. Tires and Wheels

- (a) **Condition of Tires and Wheels** - Tires and wheels shall be in safe operating condition as described in §175.80 (relating to inspection procedure).
- (b) **Tire Standards** - A vehicle specified under this subchapter shall have tires manufactured in conformance with standards in Chapter 159 (relating to new pneumatic tires). See 75 Pa.C.S. §4525 (relating to tire equipment and traction surfaces). Tires with equivalent metric size designations may be used.

- (c) **Radial Ply Tires** - A radial ply tire may not be used on same axle with a bias or belted tire.
- (d) **Different Types of Tires** - Tires of different types, such as one snow tire and one regular tire or bias, belted or radial tire, may not be used on same axle except in an emergency.
- (e) **Non-Pneumatic Tires** - A passenger car or light truck operated on highway may not be equipped with nonpneumatic tires except an antique vehicle with nonpneumatic tires if originally equipped by the manufacturer.
- (f) **Ice Grips or Studs** - A tire may not be equipped with ice grips or tire studs or wear-resisting material which have projections exceeding 2/32 inches beyond the tread of the traction surface of the tire.
- (g) **Tires and Rims** - The axles of a vehicle specified under this subchapter shall be equipped with the number and type of tires and rims with a load rating equal to or higher than those offered by the manufacturer.
- (h) **Spacers** - Spacers or similar devices thicker than 1/4 inch may not be installed to increase wheel track.

### 175.66. Lighting and Electrical Systems

- (a) **Condition of Lamps and Switches** - Every required lamp or switch shall be in safe operating condition as described in §175.80 (relating to inspection procedure).
- (b) **Lighting Standards** - A lamp shall comply with vehicle lighting equipment requirements of this title. See Tables II-IV Chapter 153 and 75 Pa.C.S. §4301.
- (c) **Headlamp System** - A vehicle specified under this subchapter which is driven on highway shall have two- or four-headlamp system. See 75 Pa.C.S. §4303 (a) (relating to general lighting requirements).
  - (1) Both lamps in the two-headlamp system shall be of Type II construction consisting of high beam and low beam. One lamp shall be located on each side of front of motor vehicle.
  - (2) In the four-headlamp system, two lamps shall be of Type II construction and two lamps shall be of Type I construction. Type I lamps consist of a high beam only. One of each type shall be located on each side of front of the motor vehicle.
  - (3) The headlamp low beam minimum candlepower shall not be less than 7,500.
  - (4) The headlamp high beam minimum candlepower shall not be less than 10,000.
  - (5) A headlamp shall be aimed to comply with inspection procedure of this subchapter.
  - (6) A vehicle specified under this subchapter shall be equipped with manual dimmer switch conveniently located for use by the driver while in normal operating position. An automatic dimming device may be used in addition to the manual switch.
  - (7) A vehicle specified under this subchapter shall be equipped with a beam indicator, which shall be lighted whenever high beam of light from the headlamp is in use and shall not otherwise be lighted. An indicator shall be located so that when lighted it is readily visible without glare to operator of vehicle.
- (d) **Total Candlepower** - The total candlepower for headlamps and auxiliary lamps shall not exceed 150,000.
- (e) **Other Required Lamps** - A vehicle specified under this subchapter shall have at least one red stop lamp on each side of rear of vehicle, which shall be illuminated immediately upon application of the service brake.
- (f) **Illumination, Except Headlamps, Fog Lamps, and Auxiliary Driving Lamps** - A vehicle specified under this subchapter shall be equipped with parking lamps, stop lamps, tail lamps, turn signal lamps and hazard warning lamps designed for that specific function, which under normal atmospheric conditions shall be capable of being seen and distinguished during nighttime operation at a distance of 500 feet. See 75 Pa.C.S. §4303(b)—(d).
  - (1) Stop lamps, turn signals and hazard warning lamps shall be visible at distance of 100 feet during normal sunlight.
  - (2) Rear lamps shall be lighted whenever head lamps, fog lamps or auxiliary driving lamps are in operation.
  - (3) A vehicle specified under this subchapter shall be equipped with hazard warning lamps unless the lamps were not included as original equipment.

## Subchapter E - Passenger Cars and Light Trucks

---

(4) The turn signals shall have a frequency of flash between 60-120 flashes per minute.

- (g) **Condition and Position of Lamps** - Lamps shall be properly fastened; direct light properly; be of a color not contrary to Tables II-IV and not be so obstructed by a screen, bar, auxiliary equipment or a device as to obscure, change the color of or obstruct beam.
- (h) **Ornamental Lamps** - A lamp not enumerated in this section and not located as described in Tables III, IV and V of this chapter, is prohibited unless it is available as original equipment. An illuminated sign is prohibited except on taxicabs, ambulances and trucks. Flashing or revolving lights are not ornamental lamps. Provisions relating to flashing or revolving lights are in Chapters 15 and 173 (relating to authorized vehicles and special operating privileges; and flashing or revolving lights on emergency and authorized vehicles).

**NOTE:** Effective December 24, 2018, Act 108 permits an illuminated sign approved by the Public Utility Commission or the Philadelphia Parking Authority to be displayed in vehicles associated with transportation network companies (e.g. Lyft, Uber).

(i) **[Reserved]**

(j) **Back-Up Lamps** - Back-up lamps are not permitted to be lighted when the vehicle is in forward motion. Back-up lamps shall turn off automatically when the vehicle goes forward. If the lamps do not turn off automatically, a dash indicator that lights or creates audible warning is required.

(k) **Registration Plate Lamp** - If the vehicle was originally so equipped, the registration plate lamp shall emit white light and make the registration plate visible from distance of 50 feet to the rear of vehicle.

(l) **Auxiliary Driving Lamps and Fog Lamps** - Auxiliary driving lamps and fog lamps may be installed on a passenger vehicle or light truck if the lamps comply with the following:

- (1) Auxiliary driving lamps shall not be substituted for headlamps. Auxiliary driving lamps may only be used with high headlamp beams.
- (2) Fog lamps may not be substituted for headlamps.
- (3) Auxiliary driving lamps and fog lamps shall be mounted on the front, spaced at least 20 inches apart from center to center and at height not more than 42 inches above level surface upon which the vehicle stands nor lower than the lowest chassis part. Rear fog lamps, if originally installed or offered as optional equipment, are acceptable.
- (4) Auxiliary driving lamps and fog lamps shall be aimed when the vehicle and lamp assembly are in straight ahead position with the beam not above horizontal centerline of lamp at 25 feet.
- (5) A vehicle specified under this subchapter may have only one pair of approved auxiliary driving lamps and fog lamps.
- (6) Auxiliary driving lamps and fog lamps shall not be placed in front of a required lamp.
- (7) Auxiliary driving lamps shall not be used on snow plows as a substitute for headlamps obscured by blade. A substitute for head-lamps used on the vehicle shall be complete, approved headlamps having both high and low beams.
- (8) Snow plow lamps shall be installed as follows:
  - (i) These lamps shall be wired through a double throw switch so that both sets of lights will not operate at same time.
  - (ii) Snow plow lamps shall be aimed so that the high intensity beam does not project to the left of the extreme left side of the vehicle nor higher than the center of the lamp at a distance of 25 feet in front of the vehicle. In no case shall the high intensity portion of a beam be higher than 42 inches above the level upon which the vehicle stands at distance of 75 feet ahead. Lamps shall be spaced at a distance of not less than 20 inches apart and shall be symmetrically located on each side of the vehicle centerline.
- (9) In accordance with 75 Pa.C.S. §4303 (f) (relating to general lighting requirements), roof or roll bar mounted off-road lights may be installed if they are not used on a high-way or trafficway and are covered with an opaque covering at all times while operating on the highway or trafficway. Vehicles equipped with roof or roll bar mounted off-road lights shall have a switch that indicates to the driver, through the use of a pilot light, that the lights are on when so switched.

- (10) White or clear cargo lamps are permitted if available as original equipment or installed in a manner which expressly illuminates the cargo area of a multipurpose passenger vehicle, truck or bus.
- (11) Guidance laser systems used during highway maintenance operations, such as line painting and snow plowing, are authorized if they comply with 21 CFR § 1040.10 (relating to laser products) for Class III a laser products and Occupational Health and Safety Administration standard 1926.54 and are installed and operated in accordance with manufacturer's requirements. Guidance laser systems shall not emit red or blue light visible to other motorists.
- (m) **Antique Vehicle Lighting Exemption** - An antique vehicle, if operated exclusively between the hours of sunrise to sunset and not during periods of reduced visibility or insufficient illumination, is exempt from requirements of this section except requirements pertaining to stop lamps.
- (n) **Battery Fastening** - A vehicle specified under this subchapter shall be equipped with a system specifically designed for the secure fastening of the battery.

### 175.67. Glazing

- (a) **Condition of Glazing** - Glazing shall meet the requirements of Chapter 161 (relating to glazing materials). See 75 Pa.C.S. §4526 (relating to safety glass).
- (b) **Safety Glazing** - A vehicle specified under this subchapter shall be equipped with safety glazing in all windshields, windows and wings. Requirements of this subsection do not apply to a vehicle manufactured or assembled before January 1, 1934, if the original glazing is not cracked or discolored.
- (c) **Stickers** - Stickers shall be located as follows:
  - (1) The following stickers are authorized to be affixed to windshield or windows, as indicated:
    - (i) Out-of-State inspection stickers, tax stamps, road use permits or other government-related permits for - municipalities and states—may be placed at the lower left or right-hand corner of windshield.
    - (ii) A Delaware River Port Authority Bridge Travel Permit may be affixed to the left rear window. This permit is 2¼ inches x 4¼ inches and is an automatic triggering device for passing vehicles through toll gates on a bridge.
    - (iii) The suggested manufacturer's retail price sheet may be affixed to a new vehicle of a dealer. These labels are permitted only on the lower portion of a side window, as far to the rear of a vehicle as possible. When the vehicle is sold, this label shall be removed.
- (d) **Obstructions** - A vehicle specified under this subchapter shall have glazing free from obstructions as described in §175.80 (relating to inspection procedure).
  - (1) With the exception of materials in paragraph (4), signs, posters or other materials whose design prevents a driver from seeing through the material may not be placed on the windshield, a side wing, a side window, or rear window so as to obstruct, obscure or impair the driver's clear view of the highway or an intersecting highway. Under FMVSS No. 205, these restrictions do not apply to the rear side windows, rear wings or rear window of trucks or multipurpose passenger vehicles.
  - (2) With the exception of materials in paragraph (4), signs, posters or other materials whose design prevents a driver from seeing through the material may not be placed on a rear side window, rear wing or rear window of a passenger car which either covers more than 20% of the exposed portion of the windows on the above line and move everything else up or wings, or extends more the 3½ inches above the lowest exposed portion of the windows or wings.
  - (3) This subsection also applies to glass etchings, except those used for vehicle identification.
  - (4) A sun screening device or other material which does not permit a person to see or view the inside of the vehicle is prohibited, unless otherwise permitted by FMVSS No. 205, or a certificate of exemption has been issued in compliance with §175.265 (relating to exemption provisions). See Table X for specific requirements for vehicles subject to this subchapter. Passenger car requirements relating to the rear window are delineated by vehicle model year in Table X.
  - (5) Vehicles specified under this subchapter may not have an obstruction forward of the windshield which extends more than 2 inches upward into the horizontally projected vision area of the windshield with the exception of windshield wiper components.

**175.68. Mirrors**

- (a) **Condition of Mirrors** - Mirrors shall be in safe operating condition as described in §175.80 (relating to inspection procedure).
- (b) **Rearview Mirrors** - A vehicle specified under this subchapter shall be equipped with at least one rearview mirror or similar device which provides the driver an unobstructed view of the highway to the rear of the vehicle for a distance of not less than 200 feet. A mirror may not be cracked, broken or discolored.
- (c) **Obstructions** - On a vehicle specified under this subchapter, a rearview mirror shall be free from obstructions as described in §175.80.
  - (1) A vehicle specified under this subchapter having a sign, load or material which obstructs, obscures or impairs the driver's clear view of the highway or an intersecting highway shall have two outside rearview mirrors, one on the driver's side and one on the passenger's side, each with a minimum reflective surface of 19.5 square inches.
  - (2) Rear window louvers are permitted only if the vehicle has at least two outside rearview mirrors, one on the driver's side and one on the passenger's side, each with minimum reflective surfaces of 19.5 square inches.
  - (3) Rearview mirrors, each with a minimum reflective surface of 19.5 square inches, shall be installed on both sides of a vehicle for which a certificate of exemption for a sun screening device or other material has been issued. A vehicle for which a certificate of exemption has been issued for medical reasons may be equipped with only a left outside rearview mirror, unless the vehicle was originally equipped with an outside rearview mirror on both sides of the vehicle.
  - (4) No object or material may be hung from the rearview mirror and no object or material may be hung, placed or attached in a position so as to materially obstruct, obscure or impair driver's vision through the windshield or constitute a safety hazard.
  - (5) This subsection also applies to glass etchings, except those used for vehicle identification.
- (d) **Motor Homes** - A motor home shall be free from obstructions as described in this subchapter.
  - (i) A vehicle manufactured as or permanently converted into a motor home with GVW of 11,000 pounds or less may have windows—approved glass only—transparent screens and roll-up shades or curtains installed if the shades and curtains are securely fastened in the completely opened position to avoid covering a portion of window while the vehicle is being operated on the highway. Venetian blinds may not cover a window while the vehicle is operated on the highway.
  - (ii) If a window is covered for installation of a wardrobe, cupboard or other convenience; it shall be factory installed or otherwise permanently installed—optional equipment or facsimile only. Two outside mirrors shall be installed to afford the operator a clear view 200 feet to rear of vehicle.

**175.69. Windshield Defrosters**

A windshield defroster system shall be in safe operating condition.

**175.70. Windshield Washers**

A windshield washer system shall be installed and in safe operating condition on passenger cars and light trucks manufactured after 1968.

**175.71. Windshield Wipers**

- (a) **Condition of Windshield Wipers** - A wiper system shall be in safe operating condition as described in §175.80 (relating to inspection procedure).
- (b) **Cleaning** - A vehicle specified under this subchapter shall be equipped with a wiper system capable of cleaning rain, snow and other moisture from windshield and constructed so as to be operated by a switch conveniently located for use by the driver while in normal operating position.
  - (1) Wipers shall operate as specified by the manufacturer or a minimum of 45 cycles per minute if not specified.

- (2) A vehicle specified under this subchapter originally equipped with two wiper blades and two wiper arms—driver and passenger side—shall have them in place and in good working order.

### 175.72. Fuel Systems

- (a) **Condition of Fuel Systems** - All components in a fuel system shall be in safe operating condition as described in §175.80 (relating to inspection procedure).
- (b) **Fuel System Requirements** - The fuel system components shall be leakproof and shall be fastened securely to the vehicle with fasteners designed for that purpose.
- (c) **Accelerator Operation** - An accelerator control system shall return engine throttle to the idle position when the operator removes the actuating force from the accelerator control.
- (d) **Filler Cap** - A fuel system shall be equipped with a filler cap.
- (e) **Alternate Fuel Systems** - See Subchapter M (relating to alternate fuel systems and controls).

### 175.73. Speedometers

A vehicle specified under this subchapter shall have an operating speedometer calibrated to indicate miles per hour or kilometers per hour.

### 175.74. Odometers

A vehicle specified under this subchapter, except a motor vehicle at least 25 years old, shall have an operating odometer calibrated to indicate total miles or kilometers driven.

### 175.75. Exhaust Systems

- (a) **Condition of Exhaust System** - All components of the exhaust system shall be in safe operating condition as described in §175.80 (relating to inspection procedure).
- (b) **Exhaust System Requirements** - A vehicle specified under this subchapter shall be constructed, equipped, maintained and operated to prevent engine exhaust gases from penetrating and collecting in any part of the vehicle occupied by the driver or a passenger, in addition to requirements of this title for an emission control system and smoke control for a diesel-powered vehicle.
- (1) A vehicle specified under this subchapter shall be equipped with a muffler or other effective noise-suppressing system in good working order and in constant operation. A muffler or exhaust system may not be equipped with a cutout, bypass or similar device and a muffler may not show evidence of external repair.
  - (2) The exhaust system of a vehicle may not be modified in a manner which will amplify or increase noise emitted by the motor of a vehicle above the maximum level permitted by Chapter 157 (relating to established sound levels).
  - (3) Headers and side exhaust are permitted if the vehicle meets the requirements of this section.
  - (4) An exposed exhaust system shall be equipped with an adequate heat shield or protective system.
  - (5) An exhaust system shall extend and discharge completely to the outside edge of the vehicle body, including a truck bed, or as originally designed.
  - (6) A firefighting vehicle is exempt from regulations concerning exhaust systems, mufflers and noise control.

### 175.76. Horns and Warning Devices

- (a) **Condition of Horns and Warning Devices** - All components of a horn or warning device shall be in safe operating condition as described in §175.80 (relating to inspection procedure).
- (b) **Horn and Warning Device Requirements** - A vehicle specified under this subchapter shall have a horn or other warning device which is audible under normal conditions at a distance of not less than 200 feet. No vehicle shall be equipped with a siren, bell, whistle or similar device emitting any unreasonably loud or harsh sound except emergency vehicles and vehicles equipped with an anti-theft device.



**175.77. Body**

- (a) **Condition of Body** - All items on the body shall be in safe operating condition as described in §175.80 (relating to inspection procedure).
- (b) **Fenders** - The wheels of a vehicle specified under this subchapter shall be equipped with fenders of a type used as original equipment. A tire may not come in contact with the body, fenders or chassis of vehicle.
- (c) **Hood and Hood Latches** - The entire motor compartment of a vehicle specified under this subchapter shall be covered by a hood. The hood shall be equipped with a double latch system to hold it in the closed position if the hood was originally so equipped.
- (d) **Protruding Objects** - There may be no torn metal, glass or other loose or dislocated parts protruding from the body of the vehicle.
- (e) **Fender Flares** - A vehicle may be equipped with fender flares not to exceed 3 inches.
- (f) **Doors** - A vehicle specified under this subchapter shall be equipped with doors of a type used as original equipment. The doors shall open and close securely unless the vehicle has been manufactured or modified to the extent that there is no roof or side. Tailgates, except on vehicles where the tailgate gives access to the passenger compartment, may be replaced with wood planking, nets or other material that will prevent loss of load. Tailgates may be removed when optional equipment, for example a truck camper, is added.

**175.78. Chassis**

- (a) **Condition of Chassis** - All items on the chassis shall be in safe operating condition as described in §175.80 (relating to inspection procedure).
- (b) **Vehicle Frame** - A vehicle frame shall be in solid condition.
- (c) **Motor Mounts** - Motor mounts may not be broken, cracked or missing.
- (d) **Flooring and Floor Beds** - Flooring and floor beds shall be of a construction to support occupants and cargo which the vehicle is capable of carrying, and may not have openings through which exhaust gases could enter passenger compartment.
- (e) **Bumpers** - A vehicle specified under this subchapter shall be equipped with bumpers of a type used as original equipment, or suitable replacement which is equal to or greater in strength than that provided by the vehicle manufacturer, securely attached to the chassis or frame. See 75 Pa.C.S. § 4536 (relating to bumpers).
  - (1) A bumper shall be of at least equivalent strength and mounting as the original equipment.
  - (2) No portion of a bumper may be broken, torn or protruding to create a hazard.
  - (3) A bumper may not extend beyond the body line or be longer than original equipment, whichever is greater.
  - (4) A wood plank bumper is permitted on a road service truck or wrecker if it is firmly attached to a regular bumper or equivalent steel backing.
  - (5) Some part of the main horizontal bumper bar on passenger vehicles shall fall within 16-20 inches above ground level.
  - (6) Some part of the main horizontal bumper bar on multipurpose passenger vehicles and light trucks shall fall within 16-30 inches above ground level.
- (f) **Seats** - A vehicle specified under this subchapter shall be equipped with a seat for an operator which is firmly anchored to the frame or a support.
  - (1) Metal springs may not protrude from the driver's seat.
  - (2) A seat adjusting mechanism may not move from a set position when so adjusted.
- (g) **Safety Belts** - A vehicle specified under this subchapter shall be equipped with safety belts of a type used as original equipment securely attached to the frame or structure. If attached to sheet metal, they shall have backing plates.
  - (1) Safety belt webbing may not be frayed.
  - (2) Belt buckles shall operate properly.

(h) **Body Mounts** - Body mounts may not be broken, cracked, deteriorated or missing.

## 175.80. Inspection Procedure

(a) **External Inspection** - An external inspection shall be performed as follows:

- (1) Verify ownership, legality, and proof of financial responsibility. For the purpose of this subchapter, ownership and legality shall be proven by a vehicle registration card, certificate of title or manufacturer's statement of origin. When a vehicle being held for resale is presented for inspection by a dealer licensed to sell vehicles in this Commonwealth, a VIN-specific auction slip or VIN-specific secure power of attorney evidencing the dealership's acquisition of the vehicle, or both, may be presented instead of a vehicle registration card, certificate of title or manufacturer's statement of origin. **REJECT IF** one or more of the following apply:
  - (i) When vehicle ownership and legality are demonstrated by presentation of certificate of title, manufacturer's statement of origin, VIN-specific auction slip or VIN-specific secure power of attorney:
    - (A) The VIN is not in agreement with the certificate of title, manufacturer's statement of origin, VIN-specific auction slip or VIN-specific secure power of attorney: Exception: If only one digit is incorrect or two digits are transposed, and the owner provides evidence that the appropriate Department form has been completed to correct the error or transposition.
    - (B) The VIN plate is not securely fastened or is defaced, misplaced or missing.
  - (ii) When vehicle ownership and legality are demonstrated by presentation of vehicle registration card:
    - (A) The license plate is not in agreement with the numbers on the vehicle registration card. Exception: If only one digit is incorrect or two digits are transposed, and the owner provides evidence that the appropriate Department form has been completed to correct an error or transposition.
    - (B) The license plate is hanging loosely from its mounting bracket.
    - (C) The license plate is obscured so that numbers cannot be identified.
    - (D) The license plate lamp, if originally so equipped, does not illuminate the license plate.
  - (iii) Acceptable proof of financial responsibility is not provided. For the purpose of this chapter, financial responsibility shall be proven by one of the following documents:
    - (A) A valid financial responsibility identification card issued in accordance with 31 Pa. Code (relating to insurance).
    - (B) The declaration page of a valid insurance policy.
    - (C) A valid self-insurance identification card.
    - (D) A valid binder of insurance issued by an insurance company licensed to sell motor vehicle liability insurance in this Commonwealth.
    - (E) A valid insurance policy issued by an insurance company licensed to sell motor vehicle liability insurance in this Commonwealth.
- (2) Check Glazing.
  - (i) **REJECT IF** any of the following apply:
    - (A) Approved safety glazing is not used in every windshield, window and wing.
    - (B) A sign, poster or other material whose design prevents a driver from seeing through the material, obstructs, obscures or impairs the driver's clear view of the highway or an intersecting highway. Under FMVSS No. 205, this restriction does not apply to the rear side windows, rear wings or rear window of trucks or multipurpose passenger vehicles.
    - (C) A sign, poster or other material, whose design prevents a driver from seeing through the material, extends more than 3½ inches from the lowest exposed portion of the rear window, rear side windows or rear wings of a passenger car.

## Subchapter E - Passenger Cars and Light Trucks

---

- (D) A vehicle displays a sticker other than those prescribed under §175.67(c) (relating to glazing), or displays a parking sticker in a location described in §175.67(d).
  - (E) Glass is shattered or broken or has exposed sharp edges.
  - (F) The windshield is removed.
  - (G) There are defects in an acute area of the windshield—center of the critical area on the driver's side of the vehicle directly in the driver's normal line of vision, 8 ½ inches wide and 5 ½ inches high—or discolorations or hazardous cracks to the front, right, left or rear of the driver which would interfere with the driver's vision.
  - (H) Glass etchings, except those used for vehicle identification, are on the windshield or front side windows.
  - (I) Glass etchings extend more than 3 ½ inches from lowest exposed portion of rear window, rear side windows or rear wings.
  - (ii) This paragraph does not prohibit the use of a product or material along the top edge of a windshield as long as the product or material is transparent and does not encroach upon the AS-1 portion of the windshield as provided by FMVSS No. 205, and the product or material is not more than 3 inches from the top of the windshield.
- (3) Check the windshield wiper system and **REJECT IF** any of the following apply:
- (i) The wipers do not operate as specified by manufacturer, or 45 cycles per minute if not specified.
  - (ii) Wiper blades are torn or smear or streak windshield after 5 cycles.
  - (iii) There is only one wiper where two are required.
  - (iv) The wipers do not return to rest position.
  - (v) The windshield washers, if originally so equipped, do not operate.
- (4) Check the door operation, including the tailgate, and **REJECT IF** one or more of the following apply:
- (i) The doors, except a tailgate on a pick-up truck, are not on the vehicle if originally fitted by the manufacturer.
  - (ii) The doors, including the tailgate, do not open and close securely, unless the vehicle has been manufactured or modified to the extent that there is no roof or side.
- (5) Check outside mirrors and **REJECT IF** one or more of the following apply:
- (i) The mirror is cracked, broken, or discolored.
  - (ii) The mirror will not hold adjustment.
  - (iii) A vehicle does not have rearview mirrors as originally equipped by the manufacturer.
  - (iv) Outside rearview mirrors, with a minimum reflective surface as described in §175.68 (relating to mirrors), are not installed on both sides of the vehicle if a certificate of exemption for a sun screening device or other material has been issued by the Department. See §175.264 (relating to mirrors). A vehicle for which a certificate of exemption has been issued for medical reasons may be equipped with only a left outside rearview mirror, unless originally equipped with an outside rearview mirror on both sides of the vehicle.
  - (v) The mirrors, if originally so equipped, are missing.
- (6) Check fenders, hood and trunk lid and **REJECT IF** one or more of the following apply:
- (i) A fender—front or rear—has been removed.
  - (ii) The fenders are not of a type and size used as original equipment.
  - (iii) The hood does not cover the entire motor compartment or cannot be fully closed.
  - (iv) The trunk lid is not present or does not close securely.
  - (v) The fender flares exceed 3 inches in width.

- (7) Check the flooring and floor beds and **REJECT IF** one or more of the following apply:
- (i) They are not in a condition to support the occupants and cargo.
  - (ii) The floor pan is rusted through so as to cause hazard to occupants or to permit exhaust gases to enter passenger compartment.
- (8) Check the bumpers and **REJECT IF** one or more of the following apply:
- (i) The bumper, if required as original equipment, is not on the vehicle.
  - (ii) The bumpers are not firmly attached to the frame or chassis.
  - (iii) Some part of the main horizontal bumper bar on passenger vehicles does not fall within 16-20 inches above ground level.
  - (iv) Some part of the main horizontal bumper bar on multipurpose passenger vehicles and light trucks does not fall within 16-30 inches above ground level.
  - (v) The broken or torn portion is protruding so as to create hazard.
  - (vi) The bumpers extend beyond body line or are longer than originally equipped, whichever is greater.
- (9) Check the lamps and lenses and **REJECT IF** one or more of the following apply:
- (i) An exterior bulb or sealed beam, if originally equipped or installed, fails to light properly, except ornamental lights.
  - (ii) The turn signal lamps do not flash between 60-120 flashes per minute.
  - (iii) The turn signal lamps do not properly indicate right or left or hold in position when so switched or do not self-cancel if originally designed to do so.
  - (iv) The back-up lamps do not turn off automatically when vehicle goes forward, there is no indicator on dash that lights or there is no audible warning signal.
  - (v) The lamp shows color contrary to lighting chart.
  - (vi) The lamp or filament indicated at the switch position does not light when the correct switch indicates the lamp should be on.
  - (vii) The lamp has a missing or broken lens.
  - (viii) A required lamp is missing.
  - (ix) The auxiliary equipment is placed on, in or in front of a lamp.
  - (x) The fog lamps operate with the high beams of the headlamps or are substituted for the low beams.
  - (xi) The auxiliary driving lamps operate with the low beam of standard headlamp system or alone.
  - (xii) The headlamps are out of adjustment as follows:
    - (A) Mechanical aimer:
      - (I) The horizontal aim is more than 4 inches to the left or right.
      - (II) The vertical aim is higher or lower than 4 inches from center.
    - (B) Screen or photo electric type tester. See Charts 1-3 (relating to headlight aiming screen distance and marking identification: high beam inspection limits: and low beam inspection limits).
      - (I) Turn the lamps on high beam and **REJECT IF** the center of the beam is horizontally more than 4 inches to the right or left of "straight ahead" or if center of light beam is vertically more than 4 inches above or below horizontal line.
      - (II) Turn the lamps on low beam and **REJECT IF** the upper edge of the beam is more than 4 inches above or below horizontal center line of head-lamp or if inner edge of beam is more than 4 inches to the right or the left of the vertical line.
- (10) Check for protruding metal and **REJECT IF** torn metal, glass or other loose or dislocated parts protrude from a surface of the vehicle so as to create a hazard.

**Subchapter E - Passenger Cars and Light Trucks**

---

- (11) Check the fuel tank cap and **REJECT IF** the fuel tank filler cap is missing.
- (12) Check the shock absorbers and **REJECT IF** the vehicle continues free rocking motion greater than three cycles after release, indicating loss of the shock absorber function.

**(b) Internal Inspection** - An internal inspection shall be performed as follows:

- (1) Check steering column and **REJECT IF** one or more of the following apply:
  - (i) Free play exceeds the following allowances:

Wheel Diameter	Freeplay
16 inches or less . . . . .	2 inches
18 inches . . . . .	2 ¼ inches
20 inches . . . . .	2 ½ inches
22 inches . . . . .	2 ¾ inches
  - (ii) The gear box is loose on the frame.
  - (iii) The energy-absorbing column is defective.
  - (iv) The steering wheel, except if specially designed for handicapped drivers, is not circular or equivalent in strength to original equipment or has an outside diameter less than 13 inches.
  - (v) The front wheels cannot be turned to the full right or left position without binding or interference.
  - (vi) The flexible steering coupler–rag joint–is badly misaligned–twisted or out of alignment between attaching collars.
  - (vii) The number of turns of the steering wheel from a straight ahead tire position to the right stop is not equal to the number of turns to the left stop within a tolerance of 1/4 turn.
- (2) Check the high beam and turn signal indicator lamps and **REJECT IF** the indicator lamps are not working.
- (3) Check the horn and **REJECT IF** any of the following apply:
  - (i) There is no horn or other acceptable audible warning device.
  - (ii) The horn or other warning device is not audible under normal conditions for distance of not less than 200 feet.
  - (iii) The vehicle is equipped with a siren, bell, whistle or any device emitting harsh or unreasonably loud sound, except emergency vehicles and vehicles equipped with an anti-theft device.
- (4) Check brake pedal and **REJECT IF** one or more of the following apply:
  - (i) The brake pedal travel exceeds 80% of the total available travel unless originally designed to do so.
  - (ii) The brake pedal fades while the vehicle is stopped unless originally designed to do so.
  - (iii) There is excessive friction in pedal linkage or components, pedal levers are misaligned or improperly positioned, or the pedal pad is missing.
  - (iv) A brake warning lamp or other device indicates a malfunction of the braking systems unless the vehicle is equipped with an antilock braking system (ABS) which is designed to revert to standard braking operation and no driveability deficiency or loss of braking performance is present.
- (5) Check the parking brake operation and **REJECT IF** the pedal or lever reaches its limit of travel before parking brakes are set.
- (6) Check the seat and safety belts, if originally equipped, and **REJECT IF** one or more of the following apply:
  - (i) The driver’s seat or back rest is not firmly attached.
  - (ii) The metal spring protrudes from driver’s seat.
  - (iii) The seat adjusting mechanism slips out of set position.
  - (iv) There is no safety belt for each seating location, if the vehicle was originally so equipped, or if seats have been added.

- (v) The safety belt webbing is frayed.
- (vi) The belt buckles do not operate properly.
- (vii) The belt anchorages are broken.
- (viii) A passive seat belt restraint system is inoperative.

(7) Check the inside mirror and **REJECT IF** one or more of the following apply:

- (i) The mirror is cracked, broken or discolored.
- (ii) The mirror will not hold adjustment.
- (iii) An object or material is hung from or blocking inside mirror.
- (iv) The mirror, if originally so equipped, is missing.

(8) Check the front windshield defroster system, if so equipped, and **REJECT IF** the defroster fan does not function.

**(c) Under the Hood Inspection** - An under the hood inspection shall be performed as follows:

(1) Check the hood and **REJECT IF** any of the following apply:

- (i) The latch does not hold securely in the fully-closed position.
- (ii) The latch release mechanism or its parts are broken, missing or so poorly adjusted that the hood cannot be closed properly.
- (iii) The double latch mechanism is not operating as originally equipped.

(2) Check the motor mounts, either here or during the beneath vehicle inspection, and **REJECT IF** the motor mounts are broken, cracked or missing.

(3) Check the fuel systems and controls and **REJECT IF** any of the following apply:

- (i) There is liquid fuel leakage at any point in system.
- (ii) A part of fuel line is not securely fastened.
- (iii) A fuel tank or line was not specifically designed or manufactured as fuel tank or line.
- (iv) A fuel line is in contact with high temperature surfaces or moving parts.
- (v) A fuel tank or line intrudes into a driver, passenger or cargo compartment except if vehicle was originally so designed. If the vehicle is equipped with an alternate fuel system, see Subchapter M (relating to alternate fuel systems and controls).
- (vi) The throttle does not return to the idle position when the actuating force is removed.
- (vii) The firewall has any holes or cracks which would permit fumes to enter driver and passenger compartments.

(4) Check the exhaust system and **REJECT IF** there is exhaust leak.

(5) Check the brake system and **REJECT IF** any of the following apply:

- (i) The master cylinder leaks.
- (ii) The power brake lines or hydraulic hoses or lines leak or are disconnected, flattened, or restricted.
- (iii) The hydraulic booster for power brake system is leaking or inoperative or has excessively worn belts that would prevent proper operation of the pump.

(6) Check the battery and **REJECT IF** the battery is not securely fastened with a device specifically designed for that function.

**(d) Visual Inspection of Emission Control System.**

Vehicles registered in counties where there is not an emission inspection program under 67 Pa. Code, Chapter 177 (relating to emission inspection program), shall be checked visually for the presence of emission control components. These components may be original vehicle equipment or an equivalent aftermarket

replacement component meeting the same standards. In addition to the exceptions under § 175.4, this subsection shall not apply to vehicles registered as collectible or classic motor vehicles as defined in 75 Pa.C.S. § 102

- (1) The visual inspection shall be performed through direct observation or through indirect observation, using a mirror or other visual aid.
- (2) Provided that the make and model year of the vehicle would have originally been equipped with the device, reject if one or more of the following apply:
  - (i) The catalytic converter has been removed, disconnected or is the wrong type for the certified vehicle configuration.
  - (ii) Exhaust gas recirculation (EGR) valve has been removed, disconnected or is the wrong type for the certified vehicle configuration.
  - (iii) Positive crankcase ventilation (PCV) valve has been removed, disconnected or is the wrong type for the certified vehicle configuration.
  - (iv) Fuel inlet restrictor has been removed, disconnected or is the wrong type for the certified vehicle configuration.
  - (v) Air pump has been removed, disconnected or is the wrong type for the certified vehicle configuration.
  - (vi) Evaporative control system components have been removed, disconnected or is the wrong type for the certified vehicle configuration.

**(e) Beneath the Vehicle Inspection** - A beneath the vehicle inspection shall be performed as follows:

- (1) Inspect tires and wheels and **REJECT IF** one or more of the following apply:
  - (i) A tire has two adjacent treads with less than 2/32-inch tread remaining at any point - less than 4/32-inch tread on front tires of the vehicles having a gross weight in excess of 10,000 pounds.
  - (ii) A tire is worn so that the tread wear indicators contact the road in any two adjacent grooves.
  - (iii) A part of ply or cord is exposed.
  - (iv) A tire has been repaired with a blowout patch or boot.
  - (v) There is a bump, bulge or separation.
  - (vi) A tire is marked "not for highway use," "for racing purposes only" or "unsafe for highway use" or has a similar designation.
  - (vii) There are other conditions or markings reasonably believed to render the tire unsafe for highway use.
  - (viii) A tire has been regrooved or recut below original tread design depth except special taxicab tires which are identified as having extra undertread rubber.
  - (ix) A tire's tread extends beyond the outer edge of the wheel housing inclusive of fender flares.
  - (x) The tires used on the same axle are not the same size or type of construction—bias, belted, radial or snow.
  - (xi) The wheel nuts or bolts are missing, loose or have improper thread engagement.
  - (xii) The stud or bolt holes are worn out of round.
  - (xiii) Part of wheel is bent, cracked, welded or damaged so as to affect safe operation of vehicle.
  - (xiv) The rear wheel does not track front wheel in straight ahead position as originally designed.
  - (xv) The wheel base on one side differs from the wheel base on the other side by more than 1 inch, unless vehicle's design specifications indicate different left and right wheel base dimension.
  - (xvi) Studded tires in use after April 15 and before November 1.
  - (xvii) Retreads on the front axle of a taxi.

- (xviii) The diameter of duals is not within 3/8-inch of each other.
  - (xix) An axle has missing tires or rims.
  - (xx) A tire makes contact with the body or chassis.
  - (xxi) Spacers over 1/4 inch in thickness are used to increase wheel track.
  - (xxii) A tire is smaller than the manufacturer's recommended minimum size or below the manufacturer's recommended load rating.
- (2) Inspect steering system and **REJECT IF** one or more of the following apply:
- (i) Steering gear box is loose on frame.
  - (ii) Measured movement at the front or rear of a tire is greater than 1/4-inch. Eliminate all wheel bearing movement by applying the service brake; then, with the vehicle raised and wheels in the straight ahead position, grasp the front and rear of the tire and attempt to move the assembly right and left without moving the steering gear. Measure the movement.
  - (iii) The linkage components are not secured with cotter pins or other suitable devices.
  - (iv) The steering stops allow the tire to rub on the frame or chassis parts.
  - (v) The front wheels are incapable of being turned to the right and left steering stops without binding or interference.
- (3) Inspect suspension system and **REJECT IF** one or more of the following apply:
- (i) The ball joint movement is in excess of the manufacturer's specifications.
  - (ii) The shock absorbers are missing.
  - (iii) The shock absorbers mounting bolts or mounts are broken.
  - (iv) The shock absorbers have severe leakage—not slight dampness.
  - (v) The sway or stabilizer bar is missing or broken.
  - (vi) The coil spring or main leaf spring is broken if originally equipped.
  - (vii) The spring attaching part is loose, badly worn, broken or missing.
  - (viii) Spring shackle kits or blocks are used to lower the suspension of the front of the vehicle.
  - (ix) Spring shackle kits are more than 2 inches over original equipment.
  - (x) Blocks are used on front axle to raise the vehicle.
  - (xi) Blocks used on rear axle exceed 5 inches over original equipment.
- (4) Inspect floor and **REJECT IF** any of the following apply:
- (i) The floor bed or inner panels have openings which would allow exhaust gases to enter either occupant compartment or trunk.
  - (ii) The floor bed is not sufficient to hold the weight of the driver, passengers and cargo.
- (5) Inspect the vehicle frame and **REJECT IF** one or more of the following apply:
- (i) The vehicle frame is not in solid condition.
  - (ii) The repairs are made with tape, tar paper or cloth, or are made in another temporary manner.
  - (iii) The frame components are missing, cracked, rotted, or broken or are in deteriorated or dangerous condition.
  - (iv) Body mounts do not hold as required.
  - (v) A body mount is broken, cracked, deteriorated or missing.
  - (vi) The difference in the body floor and the top of the frame rail exceeds 4 inches.
- (6) Inspect exhaust system and **REJECT IF** one or more of the following apply:



## Subchapter E - Passenger Cars and Light Trucks

---

- (i) The vehicle has no muffler or muffler has external repair.
  - (ii) There are loose or leaking joints.
  - (iii) There are holes, cracks or leaking seams in exhaust system.
  - (iv) There is muffler cutout or similar device.
  - (v) Part of the exhaust system passes through occupant compartment.
  - (vi) The elements are not securely fastened with proper clamps and hangers.
  - (vii) The exposed exhaust system does not have adequate heat shield or protective system.
  - (viii) The exhaust does not discharge to the outside edge of the vehicle body, including a truck bed, or as originally designed.
- (7) Inspect the braking system. Remove at least one front and one opposite rear wheel and **REJECT IF** one or more of the following apply:
- (i) The hydraulic hoses or tubing leak; is flattened, restricted, insecurely fastened, improperly retained; or have exposed cords.
  - (ii) The wheel cylinder leaks, has missing parts, is improperly retained or is not functioning.
  - (iii) The caliper leaks, has missing parts, is improperly retained or is not functioning.
  - (iv) The lining is broken; not firmly attached to shoe; or contaminated with oil, grease or any other substance that would affect proper brake operation.
  - (v) There is mechanical damage other than wear.
  - (vi) The inside diameter of drum is greater than maximum diameter stamped on drum, or greater than .090 inch over original drum diameter for unmarked drums.
  - (vii) The disc thickness is less than minimum stamped on assembly or less than manufacturer's specifications.
  - (viii) The bonded linings are less than 2/32 inch at thinnest point.
  - (ix) The riveted linings are less than 1/32 inch above rivet head at thinnest point.
  - (x) The drums or rotors are scored deeper than .015 inches.
- (8) Inspect fuel system and **REJECT IF** any of the following apply:
- (i) There is fuel leakage.
  - (ii) Part of the system is not securely fastened.
  - (iii) The system is not properly routed.

**(f) Road Test**

Perform road test and **REJECT IF** one or more of the following apply:

- (1) The parking brake fails to exhibit normal resistance when an attempt is made to move the vehicle both forward and backward from a stopped position.
- (2) The automatic transmission will not hold in the park position.
- (3) The vehicle is not capable of stopping within the maximum stopping distance prescribed in Table I (relating to brake performance) or swerves so that any part leaves a 12-foot lane.
- (4) There is a malfunction of the braking or steering mechanism, particular shimmy, wander, pull or another questionable operating behavior that affects safe operation of the vehicle.
- (5) The speedometer does not operate.
- (6) The odometer does not operate, except on a motor vehicle at least 25 years old.
- (7) The vehicle cannot be driven both forward and backward.

## Subchapter F

### MEDIUM AND HEAVY TRUCKS, BUSES AND SCHOOL BUSES

#### 175.91. Application of Subchapter

Equipment standards in this subchapter apply to medium and heavy trucks, buses and school buses driven on highways.

#### 175.92. Suspension

Every suspension component shall be in safe operating condition as described in §175.110 (relation to inspection procedure).

#### 175.93. Steering

- (a) **Condition of Steering Components** - The steering assembly and steering mechanism shall be in safe operating condition as described in §175.110 (relating to inspection procedure).
- (b) **Steering Wheel** - The steering wheel, except specially designed for handicapped drivers, shall be equivalent to original equipment in material strength and have a minimum outside diameter of 13 inches.

#### 175.94. Braking Systems

- (a) **Condition of Braking Systems** - Braking systems and components shall be in safe operating condition as described in §175.110 (relating to inspection procedure).
- (b) **Service Brakes** - Every medium and heavy truck, bus and school bus shall be equipped with a service brake system. See 75 Pa.C.S. §4502 (relating to general requirements for braking systems).
  - (1) The service brakes shall act on all wheels upon application except for the following:
    - (i) On interconnected dual wheels, brakes may act upon only one wheel.
    - (ii) A motor vehicle being towed in driveaway-towaway operation.
    - (iii) The steering axle of a truck or truck-tractor having three or more axles was manufactured before July 25, 1980. The steering axle of truck or truck-tractor having three or more axles manufactured between July 24, 1980 and October 27, 1986 shall be equipped with functioning service brakes not later than February 26, 1988.
  - (2) Service brakes, when required, shall be capable of stopping the vehicle in not more than the maximum stopping distance prescribed in Table I (relating to brake performance).
  - (3) Surge or inertia type brake systems are authorized.
  - (4) The brake lining and brake fluids shall be of type approved by the vehicle manufacturer or shall meet Society of Automotive Engineers (SAE) standards (1998, January 1980)—see Appendix A (relating to minimum requirements for motor vehicle brake lining-SAEJ998).
  - (5) A vehicle specified under this subchapter manufactured or assembled after June 30, 1967 and designated as a 1968 or later model shall be equipped with a service brake system of a design that rupture or failure of either the front or rear brake system will not result in the complete loss of braking function. Braking function may be obtained by hydraulic or other means through normal brake mechanism. In the event of a rupture or failure of an actuating force component, the unaffected brakes shall be capable of applying an adequate braking force to the vehicle.
  - (6) Metal from the shoe may not contact the brake drums or rotors.
  - (7) If a vehicle has air brakes, warning signal devices, or gauges, it shall be maintained in proper operating condition, as described in §175.110.
  - (8) A vehicle to which additional axles and wheels have been added shall be equipped with brakes on all additional wheels.
  - (9) An air chamber push rod travel may not exceed the manufacturer's specifications' maximum stroke

## Subchapter F - Medium and Heavy Trucks, Buses and School Buses

---

allowance. See Chart 4 (relating to brake chamber push rod travel typical) for a drawing of the air chamber push rod.

(10) Brake lines shall be approved for use as brake lines.

(c) **Parking Brake System** - A vehicle specified under this subchapter shall be equipped with a parking brake system. See 75 Pa.C.S. §4502.

(1) The parking brake system shall be adequate to hold the vehicle on a surface free from ice or snow on a 20% grade with the vehicle in neutral.

(2) The parking brakes shall be separately actuated so that failure of any part of the service brake actuation system does not diminish the vehicle's parking brake holding capability.

### 175.95. Tires and Wheels

(a) **Condition of Tires and Wheels** - Tires and wheels shall be in safe operating condition as described in §175.110 (relating to inspection procedure).

(b) **Tire Standards** - A vehicle specified under this subchapter shall have tires manufactured in conformance with standards contained in Chapter 159 (relating to new pneumatic tires). See 75 Pa.C.S. §4525 (relating to tire equipment and traction surfaces). Tires with equivalent metric size designations may be used.

(c) **Radial Ply Tires** - A radial ply tire shall not be used on the same axle with a bias or belted tire.

(d) **Different Types of Tires** - Tires of different types and sizes, such as one snow tire and one regular tire or bias, belted or radial tires, may not be used on the same axle except in an emergency.

(e) **Non-Pneumatic Tires** - A vehicle specified under this chapter operated on highways may not be equipped with nonpneumatic tires, except an antique vehicle with nonpneumatic tires if originally equipped by the manufacturer.

(f) **Ice Grips or Studs** - A tire may be equipped with ice grips or tire studs of wear-resisting material which have projections exceeding 2/32 inch beyond the tread of the traction surface of the tire.

(g) **Tires and Rims** - The axles of a vehicle specified under this subchapter shall be equipped with the number and type of tires and rims with a load rating equal to or higher than those offered by the manufacturer.

(h) **Exceptions** - Subsection (b), insofar as it requires tires to conform to the vehicle manufacturer's specifications as to tire size, and subsection (g) are not applicable if the Department has issued a permit under 75 Pa.C.S. §4969 (relating to permit for movement of vehicles with oversize wheels and tires) authorizing the vehicle to be operated with oversize wheels and tires.

### 175.96. Lighting and Electrical Systems

(a) **Condition of Lamps and Switches** - Every required lamp or switch shall be in safe operating condition as described in §175.110 (relating to inspection procedure).

(b) **Lighting Standards** - Lamps shall comply with vehicle lighting equipment requirements of this title. See Appendix A and Tables II-III-IV of Chapter 153 (relating to lamps, reflective devices and associated equipment); and 75 Pa.C.S. §4301 (relating to promulgation of regulations by Department).

(c) **Headlamp System** - A vehicle specified under this subchapter driven on a highway shall have two- or four-headlamp system. See 75 Pa.C.S. §4303(a) (relating to general lighting requirements).

(1) Both lamps in a two-headlamp system shall be of Type II construction consisting of high beam and low beam. One lamp shall be located on each side of front of the motor vehicle.

(2) In the four-headlamp system, two lamps shall be of Type II construction and two lamps shall be of Type I construction. A Type I lamp consists of a high beam only. One of each type shall be located on each side of the front of the motor vehicle.

(3) The headlamp low beam minimum candlepower shall not be less than 7,500.

(4) The headlamp high beam minimum candlepower shall not be less than 10,000.

(5) Every headlamp shall be aimed to comply with inspection procedure of this subchapter.

- (6) A vehicle specified under this subchapter be equipped with manual dimmer switch conveniently located for use by the driver while in a normal operating position. An automatic dimming device may be used in addition to a manual switch.
- (7) A vehicle specified under this subchapter shall be equipped with a beam indicator, which shall be lighted whenever the high beam of light from the headlamp is in use, and shall not otherwise be lighted. The indicator shall be located so that when lighted, it is readily visible without glare to the operator of the vehicle.
- (d) **Total Candlepower** - Total candlepower for headlamps and auxiliary lamps shall not exceed 150,000.
- (e) **Other Required Lamps** - A vehicle specified under this subchapter shall have at least one red stop lamp on each side of the rear of the vehicle, which shall be illuminated immediately upon application of the service brake.
- (f) **Illumination, except Headlamps, Fog Lamps, and Auxiliary Driving Lamps** - A vehicle specified under this subchapter shall be equipped with parking lamps, stop lamps, tail lamps, turn signal lamps and hazard warning lamps designed for that specific function which, under normal atmospheric conditions, shall be capable of being seen and distinguished during nighttime operation at a distance of 500 feet. See 75 Pa.C.S. §4303(b)-(d).
  - (1) Stop lamps, turn signals and hazard warning lamps shall be visible at a distance of 100 feet during normal sunlight.
  - (2) Rear lamps shall be lighted whenever headlamps, fog lamps or auxiliary driving lamps are in operation.
  - (3) A vehicle specified under this subchapter shall be equipped with hazard warning lamps, unless these lamps were not included as original equipment.
  - (4) The turn signals shall have frequency of flash between 60-120 flashes per minute.
- (g) **Condition and Position of Lamps** - Lamps shall be properly fastened; direct light properly; be of a color not contrary to Tables II-IV; and may not be so obstructed by a screen, bar, auxiliary equipment or a device so as to obscure, change the color of or obstruct the beam. Exception: A bus used for public transportation may be equipped with a device used to carry pedalcycles mounted on the front of the bus if the device, including the pedalcycle, does not extend more than 36 inches.
- (h) **Ornamental Lamps** - A lamp not enumerated in this section, and not located as described in Tables III-V of this chapter, is prohibited unless it is available as original equipment. An illuminated sign is prohibited except on taxicabs, ambulances and trucks. Flashing or revolving lights are not ornamental lamps. Provisions relating to flashing or revolving lights are in Chapters 15 and 173 (relating to authorized vehicles and special operating privileges; and flashing or revolving lights on emergency and authorized vehicles).
- (i) **[Reserved]**.
- (j) **Back-Up Lamps** - Back-up lamps are not permitted to be lighted when the vehicle is in forward motion. Back-up lamps shall turn off automatically when the vehicle goes forward. If the lamps do not turn off automatically, a dash indicator that lights or creates audible warning is required.
- (k) **Registration Plate Lamp** - If the vehicle was originally so equipped, the registration plate lamp shall emit white light and make registration plate visible from distance of 50 feet to rear of vehicle. This requirement does not apply to a vehicle which has the registration plate mounted on the front of the vehicle.
- (l) **Auxiliary Driving Lamps and Fog Lamps** - Auxiliary driving lamps and fog lamps may be installed on a medium or heavy truck and bus if the lamps comply with the following:
  - (1) Auxiliary driving lamps shall not be substituted for headlamps. Auxiliary driving lamps may only be used with high headlamp beams.
  - (2) Fog lamps are not permitted to be substituted for headlamps.
  - (3) Auxiliary driving lamps and fog lamps shall be mounted on the front, spaced not less than 20 inches apart from center to center and at a height not more than 42 inches above level surface upon which the vehicle stands, nor lower than the lowest chassis part. Rear fog lamps, if originally installed or offered as optional equipment are acceptable.
  - (4) Auxiliary driving lamps and fog lamps shall be aimed when the vehicle and lamp assembly are in the straight ahead position with beam not above the horizontal centerline of lamp at 25 feet.

## Subchapter F - Medium and Heavy Trucks, Buses and School Buses

---

- (5) A vehicle specified under this subchapter may have only one pair of approved auxiliary driving lamps and fog lamps.
  - (6) Auxiliary driving lamps and fog lamps shall not be placed in front of a required lamp.
  - (7) Auxiliary driving lamps shall not be used on snowplows as a substitute for headlamps obscured by blade. A substitute for head-lamps used on these vehicles shall be complete, approved headlamps having both high and low beams.
  - (8) Snowplow lamps shall be installed as follows:
    - (i) These lamps shall be wired through a double throw switch so that both sets of lights will not operate at the same time.
    - (ii) Snowplow lamps shall be aimed so that the high intensity beam does not project to the left of the extreme left side of the vehicle, nor higher than the center of the lamp at a distance of 25 feet in front of vehicle. In no case shall the high intensity portion of a beam be higher than 42 inches above the level surface upon which vehicle stands at a distance of 75 feet ahead. The lamps shall be spaced at a distance of not less than 20 inches apart and shall be symmetrically located on each side of the vehicle centerline.
  - (9) In accordance with 75 Pa.C.S. §4303(f), roof or roll bar mounted off-road lights may be installed if they are not used on a highway or trafficway and are covered with an opaque covering at all times while operating on the highway or trafficway. Vehicles equipped with roof or roll bar mounted off-road lights shall have a switch that indicates to the driver, through the use of a pilot light, that the lights are on when so switched.
  - (10) White or clear cargo lamps are permitted if available as original equipment or installed in a manner which expressly illuminates the cargo area of a truck or bus.
  - (11) Guidance laser systems used during highway maintenance operations, such as line painting and snow plowing are authorized if they comply with 21 CFR § 1040.10 (relating to laser products) for Class IIIa laser products and Occupational Health and Safety Administration Standard 1926.54 and are installed and operated in accordance with manufacturer's requirements. Guidance laser systems may not emit red or blue light visible to other motorists.
- (m) Antique Vehicle Lighting Exemption** - An antique vehicle, if operated exclusively between the hours of sunrise to sunset and not during periods of reduced visibility or insufficient illumination, is exempt from the requirements of this section, except requirements pertaining to stop lamps.
- (n) Battery Fastening** - A vehicle specified under this subchapter shall be equipped with a system specifically designed for the secure fastening of the battery.

### 175.97. Glazing

- (a) Condition of Glazing** - Glazing shall meet requirements of Chapter 161 (relating to glazing materials). See 75 Pa.C.S. §4526 (relating to safety glass).
- (b) Safety Glazing**
- (1) A vehicle specified under this subchapter shall be equipped with safety glazing in all windshields, windows, and wings. Requirements of this subsection do not apply to a vehicle manufactured or assembled before January 1, 1934, if the original glazing is not cracked or discolored.
  - (2) Rigid plastic glazing may be used in doors and windows of buses except windshields and windows to the immediate right or left of the driver.
- (c) Stickers**
- (1) The following stickers are authorized to be affixed to the windshield or windows as indicated:
    - (i) Out-of-state inspection stickers, school bus stickers, tax stamps, road use permits or other government-related permits—municipalities and states—may be placed at the lower left- or right-hand corner of the windshield.

- (ii) A Delaware River Port Authority Bridge Travel Permit may be affixed to the left rear window. This permit is 2 ¼ inches x 4 ¼ inches and is an automatic triggering device for passing vehicles through toll gates on bridge.
- (iii) The suggested manufacturer's retail price sheet may be affixed to a new vehicle of a dealer. These labels are permitted only on the lower portion of a side window, as far to the rear of the vehicle as possible. When the vehicle is sold, this label shall be removed.

**(d) Obstructions** - A vehicle specified under this subchapter shall have glazing free from obstructions as described in §175.110 (relating to inspection procedure).

- (1) With the exception of materials in paragraph (3), signs, posters or other materials, whose design prevents a driver from seeing through the material, may not be placed on the windshield or a side wing or a side window so as to obstruct, obscure or impair the driver's clear view of the highway or an intersecting highway. Under FMVSS No. 205, these restrictions do not apply to the rear side windows, rear wings or rear window.
- (2) The requirements of this subsection also apply to glass etchings, except those used for vehicle identification.
- (3) A sun screening device or other material which does not permit a person to see or view the inside of the vehicle is prohibited unless otherwise permitted by FMVSS No. 205, or a certificate of exemption has been issued in compliance with §175.265 (relating to exemption provisions). See Table X for specific requirements for vehicles subject to this subchapter.

**175.98. Mirrors**

**(a) Condition of Mirrors** - Mirrors shall be in safe condition as described in §175.110 (relating to exemption provisions).

**(b) Rearview Mirrors** - A vehicle specified under this subchapter shall be equipped with at least one rearview mirror, or similar device which provides driver unobstructed view of the highway to the rear of the vehicle for a distance of not less than 200 feet. Mirrors shall not be cracked, broken or discolored.

**(c) Obstructions** - On a vehicle specified under this subchapter, the rearview mirror shall be free from obstructions as described in §175.110.

- (1) A vehicle specified under this subchapter having a sign or load or another material which obstructs, obscures or impairs driver's clear view of the highway or an intersecting highway shall have two outside rearview mirrors, one on the driver's side and one on the passenger's side, each with minimum reflective surface as follows:

<b>Required Reflective Surface</b>	<b>Gross Vehicle Weight</b>
19.5 square inches . . . .	Less than 10,001 pounds
50 square inches . . . . .	Over 10,000 pounds

- (2) Rear window louvers are permitted only if the vehicle has at least two outside rearview mirrors, one on driver's side and one on the passenger's side, each with minimum reflective surface of 19.5 square inches. This paragraph does not apply to school buses.
- (3) Rearview mirrors, each with a minimum reflective surface of 19.5 square inches, shall be installed on both sides of a vehicle for which a certificate of exemption for a sun screening device or other material has been issued. A vehicle for which a certificate of exemption has been issued for medical reasons may be equipped with only a left outside rearview mirror, unless originally equipped with an outside rearview mirror on both sides of the vehicle.
- (4) An object or material may not be hung from rearview mirror and an object or material may not be hung, placed or attached in such position that materially obstructs, obscures, or impairs driver's vision through windshield or in a manner that constitutes a safety hazard.
- (5) This subsection also applies to glass etchings, except those used for vehicle identification.

- (d) **Motor Homes** - A motor home shall be free from obstructions as described in this subchapter.
- (1) A vehicle manufactured as or permanently converted into motor home with a GVW of 11,001 pounds or more may have windows, approved glass only, transparent screens and roll-up shades or curtains installed if the shades and curtains are securely fastened in completely opened position to avoid covering a portion of a window, while the vehicle is being operated on the highway. Venetian blinds may not cover a window while the vehicle is operated on a highway.
  - (2) If a window is covered for installation of wardrobe, cupboard or other convenience, it shall be factory installed or otherwise permanently installed optional equipment or facsimile only. Two outside mirrors shall be installed to afford the operator a clear view 200 feet to the rear of the vehicle.

**175.99. Windshield Defrosters**

The windshield defroster system shall be in safe operating condition.

**175.100. Windshield Washers**

The windshield washer system shall be installed and in safe operating condition on medium and heavy trucks and buses manufactured after 1968.

**175.101. Windshield Wipers**

- (a) **Condition of Windshield Wipers** - The wiper system shall be in safe operating condition as described in §175.110 (relating to inspection procedure).
- (b) **Cleaning** - A vehicle specified under this subchapter shall be equipped with wiper system, capable of cleaning rain, snow and other moisture from the windshield and constructed so as to be operated by a switch conveniently located for use by the driver while in normal operating position.
- (1) Wipers shall operate as required by the manufacturer or a minimum of 45 cycles per minute if not specified.
  - (2) A vehicle specified under this subchapter originally equipped with two wiper blades and two wiper arms—driver and passenger side—shall have them in place and in good working order.

**175.102. Fuel Systems**

- (a) **Condition of Fuel Systems** - All components in a fuel system shall be in safe operating condition as described in §175.110 (relating to inspection procedure).
- (b) **Fuel System Requirements** - Fuel system components shall be leakproof and shall be fastened securely to the vehicle with fasteners designed for that purpose.
- (c) **Accelerator Operation** - An accelerator control system shall return the engine throttle to the idle position when the operator removes the actuating force from accelerator control.
- (d) **Filler Cap** - A fuel system shall be equipped with a filler cap.
- (e) **Alternate Fuel Systems** - See Subchapter M (relating to alternate fuel systems and controls).

**175.103. Speedometers**

A vehicle specified under this subchapter shall have an operating speedometer calibrated to indicate miles per hour or kilometers per hour.

**175.104. Odometers**

A vehicle specified under this subchapter shall have an operating odometer calibrated to indicate total miles or kilometers driven, except a motor vehicle at least 25 years old or a vehicle over 17,000 pounds registered gross weight.

**175.105. Exhaust Systems**

- (a) **Condition of Exhaust System** - All components of the exhaust system shall be in safe operating condition as described in §175.110 (relating to inspection procedure).
- (b) **Exhaust System Requirements** - A vehicle specified under this subchapter shall be constructed, equipped, maintained and operated to prevent engine exhaust gases from penetrating and collecting in any part of the vehicle occupied by the driver or a passenger, in addition to the requirements of this title for emission control systems and smoke control for a diesel-powered vehicle.
- (1) A vehicle specified under this subchapter shall be equipped with a muffler or other effective noise-suppressing system in good working order and in constant operation. A muffler or exhaust system may not be equipped with a cutout, bypass or similar device, and a muffler may not show evidence of external repair.
  - (2) The exhaust system of a vehicle may not be modified in a manner which will amplify or increase noise emitted by the motor of a vehicle above the maximum level permitted by Chapter 157 (relating to established sound levels).
  - (3) Headers and side exhaust are permitted if the vehicle meets the requirements of this section.
  - (4) An exposed exhaust system shall be equipped with an adequate heat shield or protective system.
  - (5) An exhaust system shall extend and discharge completely to the outside edge of the vehicle body, including a truck bed, or as originally designed, except for the following:
    - (i) **Gasoline powered buses, including school buses.** The exhaust system of a bus powered by a gasoline engine shall discharge to the atmosphere at or within 6 inches forward of the rearmost part of the bus.
    - (ii) **Buses, including school buses, powered by fuels other than gasoline.** The exhaust system of a bus using fuels other than gasoline shall discharge to the atmosphere either at or within 15 inches forward of the rearmost part of the vehicle; or to the rear of all doors or windows designed to be opened, except windows designed to be opened solely as emergency exits.
- (c) **Exemption:** A firefighting vehicle is exempt from this section.

**175.106. Horns and Warning Devices**

- (a) **Condition of Horns and Warning Devices** - Components of a horn or warning device shall be in safe operating condition as described in §175.110 (relating to inspection procedure).
- (b) **Horn and Warning Device Requirements** - A vehicle specified under this subchapter shall have a horn or other warning device which is audible under normal conditions at distance of not less than 200 feet. No vehicle shall be equipped with siren, bell, whistle or similar device emitting any unreasonably loud or harsh sound, except emergency vehicles and vehicles equipped with an antitheft device.

**175.107. Body**

- (a) **Condition of Body** - All items on the body shall be in safe operating condition as described in §175.110 (4-02) (relating to inspection procedure).
- (b) **Fenders** - The wheels of a vehicle specified under this subchapter shall be equipped with fenders of a type used as original equipment. A tire may not come in contact with body, fenders or chassis of vehicle, at any time.
- (c) **Hood and Hood Latches** - The entire motor compartment of a vehicle specified under this subchapter shall be covered by a hood. The hood shall be equipped with a double latch system to hold it in the closed position if the hood was originally so equipped.
- (d) **Protruding Objects** - Torn metal, glass or other loose or dislocated parts may not protrude from the body of the vehicle.
- (e) **Fender Flares** - A vehicle may be equipped with fender flares not to exceed 3 inches.



- (f) **Doors** - A vehicle specified under this subchapter shall be equipped with doors of a type used as original equipment. The doors shall open and close securely unless the vehicle has been manufactured or modified to the extent that there is no roof or side. Tailgates, except on vehicles where the tailgate gives access to the passenger compartment, may be replaced with wood planking, nets or other material that will prevent loss of load. Tailgates may be removed when optional equipment, for example a truck camper, is added.

**175.108. Chassis**

- (a) **Condition of Chassis** - All items on the chassis shall be in safe operating condition as described in §175.110 (relating to inspection procedure).
- (b) **Vehicle Frame** - A vehicle frame shall be in solid condition.
- (c) **Motor Mounts** - The motor mounts may not be broken, cracked or missing.
- (d) **Flooring and Floor Beds** - Flooring and floor beds shall be of a construction to support occupants and cargo which the vehicle is capable of carrying, and shall not have any openings through which exhaust gases could enter passenger compartment.
- (e) **Front Bumper** - Every vehicle specified under this subchapter shall be equipped with front bumper or a suitable replacement which is equal to or greater in strength than that provided by the vehicle manufacturer, securely attached to chassis or frame. See 75 Pa.C.S. §4536 (relating to bumpers).
- (1) A bumper shall be of at least equivalent strength and mounting as the original equipment.
  - (2) No portion of bumper shall be broken, torn or protruding as to create a hazard.
  - (3) No bumper shall extend beyond the body line or be longer than original equipment, whichever is greater.
  - (4) A wood plank bumper is permitted on a road service truck or wrecker, if firmly attached to a regular bumper or equivalent steel backing.
  - (5) Some part of the horizontal bumper bar shall fall within 16-30 inches above ground level.
- (f) **Rear Protection Device** - A vehicle specified under this subchapter, except truck tractors, whose body or chassis has a rear end clearance of more than 30 inches from the ground when empty, shall be equipped with a rear bumper or rear end protection devices as follows:
- (1) The rear bumper or rear end protection device shall be:
    - (i) Within 30 inches of ground when the vehicle is empty.
    - (ii) Within 24 inches of another rear bumper or rear end protection device, if more than one rear bumper or rear end protection device is used.
    - (iii) Within 18 inches—transverse distance—of the widest part of the rear of the vehicle.
    - (iv) Within 24 inches of the extreme rear of the vehicle.
    - (v) Substantially constructed and firmly attached.
  - (2) Vehicles constructed and maintained so that the body, chassis or other parts of the vehicle afford the rear end protection described in paragraph (1) will be deemed to be in compliance with this subsection.
  - (3) No bumper shall extend beyond the body or line or be longer than original equipment, whichever is greater.
  - (4) A wood plank bumper is permitted on a road service truck or wrecker if firmly attached to a regular bumper or equivalent steel backing.
  - (5) Some part of the horizontal bumper bar shall fall within 16-30 inches above ground level.
- (g) **Fenders and Flaps** - A vehicle specified under this subchapter shall be equipped with fenders which provide at least as much coverage of the wheel as original equipment. Wheels shall be sufficiently covered with fenders or flaps to prevent loose objects, rain, snow, and the like from being thrown about in a manner which may interfere with other persons using the highways.

- (h) **Rear Wheel Shields** - A vehicle specified under this subchapter, except a truck-tractor while towing a trailer, shall be constructed or equipped to bar water or other road surface substances thrown from the rear wheels of the vehicle or combination at tangents exceeding 22.5°, measured from the road surface, from passing in a straight line to the rear of the vehicle or combination. See 75 Pa.C.S. §4533 (relating to rear wheel shields).
- (i) **[Reserved]**.
- (j) **Seats** - A vehicle specified under this subchapter shall be equipped with an operator seat which is firmly anchored to frame or support.
  - (1) No metal spring shall protrude from driver's seat.
  - (2) A seat adjusting mechanism shall not move from set position when so adjusted.
- (k) **Safety Belts** - A vehicle specified under this subchapter shall be equipped with safety belts, of a type used as original equipment, securely attached to frame or structure. If attached to sheet metal they shall have backing plates.
  - (1) Safety belt webbing shall not be frayed.
  - (2) Belt buckles shall operate properly.
- (l) **Body Mounts** - Body mounts may not be broken, cracked, deteriorated or missing.

### 175.110. Inspection Procedure

- (a) **External Inspection** - An external inspection shall be performed as follows:
  - (1) Verify ownership, legality, and proof of financial responsibility. For the purpose of this subchapter, ownership and legality shall be proven by a vehicle registration card, certificate of title or manufacturer's statement of origin. When a vehicle being held for resale is presented for inspection by a dealer licensed to sell vehicles in this Commonwealth, a VIN-specific auction slip or VIN-specific secure power of attorney evidencing the dealership's acquisition of the vehicle, or both, may be presented instead of a vehicle registration card, certificate of title or manufacturer's statement of origin.  
**REJECT IF** one or more of the following apply:
    - (i) When vehicle ownership and legality are demonstrated by presentation of certificate of title, manufacturer's statement of origin, VIN-specific auction slip or VIN-specific secure power of attorney:
      - (A) The VIN is not in agreement with the certificate of title, manufacturer's statement of origin, VIN-specific auction slip or VIN-specific secure power of attorney. Exception: If only one digit is incorrect or two digits are transposed, and the owner provides evidence that the appropriate Department form has been completed to correct the error or transposition.
      - (B) The VIN plate is not securely fastened or is defaced, misplaced or missing.
    - (ii) When vehicle ownership and legality are demonstrated by presentation of vehicle registration card:
      - (A) The license plate is not in agreement with numbers on vehicle registration card. Exception: If only one digit is incorrect or two digits are transposed, and the owner provides evidence that the appropriate Department form has been completed to correct an error or transposition.
      - (B) The license plate is hanging loosely from its mounting bracket.
      - (C) The license plate is obscured so that the numbers cannot be identified.
      - (D) The license plate lamp, if so equipped, does not illuminate the license plate, except truck-tractors.
    - (iii) Acceptable proof of financial responsibility is not provided. For the purpose of this chapter, financial responsibility shall be proven by one of the following documents:
      - (A) A valid financial responsibility identification card issued in accordance with 31 Pa. Code (relating to insurance).

- (B) The declaration page of a valid insurance policy.
  - (C) A valid self-insurance identification card.
  - (D) A valid binder of insurance issued by an insurance company licensed to sell motor vehicle liability insurance in this Commonwealth.
  - (E) A valid insurance policy issued by an insurance company licensed to sell motor vehicle liability insurance in this Commonwealth.
- (2) Check the Glazing.
- (i) **REJECT IF** one or more of the following apply:
    - (A) Approved safety glazing is not used in every windshield, window or wing.
    - (B) A sign, poster or other material whose design prevents a driver from seeing through the material, obstructs, obscures or impairs the driver's clear view of the highway or an intersecting highway. In accordance with FMVSS No. 205, this restriction does not apply to the rear side windows, rear wings or rear window of vehicles subject to this subchapter.
    - (C) A vehicle displays a sticker other than those prescribed under §175.97(c) (relating to glazing), or displays a parking sticker in a location described in §175.97(d).
    - (D) The glass is shattered, broken or has any exposed sharp edges.
    - (E) The windshield is removed.
    - (F) There are defects in an acute area of windshield—center of the critical area on the driver's side of the vehicle directly in driver's normal line of vision—8 ½ inches wide and 5 ½ inches high—or discolorations or hazardous cracks to the front, right, left or rear of the driver which would interfere with the driver's vision.
    - (G) Glass etchings, except those used for vehicle identification, are on windshield or front side windows.
    - (H) Glass etchings extend more than 3 ½ inches from lowest exposed portion of rear window, rear side windows or rear wings.
  - (ii) This paragraph does not prohibit the use of a product or material along the top edge of the windshield as long as the product or material is transparent and does not encroach upon the AS-1 portion of the windshield as provided by FMVSS No. 205, and the product or material is not more than 3 inches from the top of the windshield.
- (3) Check the windshield wiper system and **REJECT IF** one or more of the following apply:
- (i) The wipers do not operate as specified by the manufacturer or 45 cycles per minute if not specified.
  - (ii) The wiper blades are torn or smear or streak the windshield after five cycles.
  - (iii) There is only one wiper, where two are required.
  - (iv) Wipers do not return to rest position.
  - (v) The windshield washers, if originally so equipped, do not operate.
- (4) Check the door operation, including tailgate, and **REJECT IF** one or more of the following apply:
- (i) The doors are not on the vehicle if originally fitted by manufacturer.
  - (ii) The doors, including the tailgate, if so equipped, do not open and close securely.
  - (iii) Tailgate or equivalent is not on the vehicle, unless removed for the addition of optional equipment that is present at the time of the inspection.
- (5) Check the outside mirrors and **REJECT IF** one or more of the following apply:
- (i) A required mirror is cracked, broken, missing or discolored.
  - (ii) A mirror will not hold adjustment.

- (iii) The vehicle does not have a mirror where required for the driver’s side and one on the opposite side, each with a minimum reflective surface as follows:

<b>Gross Vehicle Weight</b>	<b>Required Reflective Surface</b>
Less than 10,001 pounds . . . . .	19.5 square inches
Over 10,000 pounds . . . . .	50 square inches

- (iv) Outside rearview mirrors, with a minimum reflective surface as described in §175.98 (relating to mirrors), are not installed on both sides of the vehicle if a certificate of exemption for a sun screening device or other material has been issued by the Department. See §175.264 (relating to mirrors). A vehicle for which a certificate of exemption has been issued for medical reasons may be equipped with only a left outside rearview mirror, unless originally equipped with an outside rearview mirror on both sides of the vehicle.
- (6) Check fenders, hood and truck lid and **REJECT IF** any of the following apply:
- (i) Any fender, front and rear, has been removed.
  - (ii) The fenders are not of a type and size used as original equipment.
  - (iii) The hood does not cover the entire motor compartment or cannot be fully closed.
  - (iv) The trunk lid does not close.
  - (v) The fender flares exceed 3 inches in width.
- (7) Check flooring and floor beds and **REJECT IF** any of the following apply:
- (i) They are not in a condition to support the occupants and cargo.
  - (ii) The floor pan is rusted through so as to cause hazard to occupants or to permit exhaust gases to enter passenger compartment.
  - (iii) Not equipped with rear wheel shields – mud flaps—as required under 75 Pa.C.S. §4533 (relating to rear wheel shields).
  - (iv) The lamps or wiring are attached to any guard or flap.
  - (v) A flap or guard does not consist of suitable metal protectors or substantial flexible flaps which are strong enough to prevent stones or objects being thrown through them.
  - (vi) On buses, reject if any of the following apply:
    - (A) The step well or floor on the bus is cluttered or worn to present tripping hazard.
    - (B) The guard rails or grab rails on the bus are loose or fastening parts are missing.
    - (C) The service doors on a bus, bind, jam or malfunction, preventing proper operation
    - (D) The emergency exit is not easily accessible.
    - (E) The inside or outside quick release mechanism on emergency doors or windows on the bus fails to function positively or opens accidentally or too easily.
- (8) Check bumpers and **REJECT IF** any of the following apply:
- (i) The bumpers are not on the vehicle if required as original equipment.
  - (ii) The bumpers are not firmly attached to frame or chassis.
  - (iii) Some part of horizontal bumper bar on medium and heavy trucks and buses does not fall within 16-30 inches above ground level.
  - (iv) A broken or torn portion is protruding, so as to create hazard.
  - (v) The bumper extends beyond the body line or is longer than originally equipped, whichever is greater.
- (9) Check the lamps and lenses and **REJECT IF** one or more of the following apply:
- (i) An exterior bulb or sealed beam, if originally equipped or installed, fails to light properly, except ornamental lights.

**Subchapter F - Medium and Heavy Trucks, Buses and School Buses**

---

- (ii) The turn signal lamps do not flash between 60-120 flashes per minute.
- (iii) The turn signal lamps do not properly indicate the right or left or hold in position when so switched or do not self-cancel if originally designed to do so.
- (iv) The back-up lamp does not turn off automatically when vehicle goes forward, there is no indicator on dash that lights or there is no audible warning signal.
- (v) The lamp shows a color contrary to the lighting chart.
- (vi) The lamp or filament indicated at the switch position does not light when the correct switch indicates the lamp should be on.
- (vii) The lamp has missing or broken lens.
- (viii) A required lamp is missing.
- (ix) The auxiliary equipment is placed on, in or in front of a lamp. Exception: A bus used for public transportation may be equipped with a device used to carry pedalcycles mounted on the front of the bus if the device, including the pedalcycle, does not extend more than 36 inches.
- (x) The fog lamps operate with the high beams of headlamps.
- (xi) The auxiliary driving lamps operate with the low beam of a standard headlamp system or alone.
- (xii) The headlamps are out of adjustment as follows:

(A) Mechanical aimer:

- (I) The horizontal aim is more than 4 inches to left or right.
- (II) The vertical aim is higher or lower than 4 inches from center.

(B) Screen or photo electric type tester. See Charts 1-3 (relating to headlight aiming screen distance and marking identification; high beam inspection limits; and low beam inspection limits):

- (I) Turn lamps on high beam and **REJECT IF** the center of the beam is horizontally more than 4 inches to the right or left of straight ahead or if the center of the light beam is vertically more than 4 inches above or below horizontal line.
- (II) Turn lamps on low beam and **REJECT IF** the upper edge of the beam is more than 4 inches above or below horizontal center line of headlamp or if inner edge of beam is more than 4 inches to right or left of vertical line.

- (10) Check for protruding metal and **REJECT IF** torn metal, glass or other loose or dislocated parts protrude from the surface of the vehicle so as to create a hazard.
- (11) Check fuel tank cap and **REJECT IF** fuel tank filler cap is missing.
- (12) Check the shock absorbers and **REJECT IF** the vehicle continues a free rocking motion greater than three cycles after release, indicating loss of shock absorber function.
- (13) Inspect the fifth wheel completely and **REJECT IF** any of the following apply:
  - (i) The lower half of the fifth wheel is not securely affixed by U-bolts or by other secure means.
  - (ii) The lower half of the fifth wheel is cracked, loose, missing or has inoperative locking devices.

**(b) Internal Inspection** - An internal inspection shall be performed as follows:

- (1) Check steering column completely and **REJECT IF** one or more of the following apply:
  - (i) Freeplay exceeds the following allowances:

<b>Wheel Diameter</b>	<b>Freeplay</b>
16 inches or less . . . . .	.2 inches
18 inches . . . . .	.2 ¼ inches
20 inches . . . . .	.2 ½ inches
22 inches . . . . .	.2 ¾ inches

- (ii) The gear box is loose on the frame.
  - (iii) The energy absorbing column is defective.
  - (iv) The steering wheel, except specially designed for handicapped drivers, is not circular or equivalent in strength to original equipment, or has outside diameter less than 13 inches.
  - (v) The front wheels cannot be turned to the full right or left position without binding or interference.
  - (vi) The flexible steering coupler–rag joint–is badly misaligned–twisted or out of alignment between attaching collars.
  - (vii) The U-Bolts, or positioning parts, are absent or loose. Some steering column systems are designed to permit some movement.
  - (viii) The steering wheel is not properly secured.
- (2) Check high beam and turn signal indicator lamps and **REJECT IF** indicator lamps are not working.
- (3) Check horn and **REJECT IF** any of the following apply:
- (i) There is no horn or other acceptable audible warning device.
  - (ii) The horn or other warning device is not audible under normal conditions for distance of not less than 200 feet.
  - (iii) The vehicle is equipped with a siren, bell, whistle, or a device emitting a harsh or unreasonably loud sound, except on emergency vehicles and vehicles equipped with antitheft device.
- (4) Check brake pedal and **REJECT IF** any of the following apply:
- (i) The brake pedal travel exceeds 80% of total available travel.
  - (ii) The brake pedal fades while vehicle is stopped.
  - (iii) There is excessive friction in the pedal linkage or components if the pedal levers are misaligned or improperly positioned, or the pedal pad is missing.
  - (iv) The low-vacuum indicator fails to activate at a reading of 8 inches Hg (Mercury).
  - (v) Any brake warning system is not working.
  - (vi) Air brakes, if any of the following apply:
    - (A) With the engine stopped and brakes not applied, the gauge indicates loss of more than 3 pounds per minute.
    - (B) With the engine running, the gauge indicates a loss of more than 4 pounds per minute after the full brake application for 2 minutes.
    - (C) With the engine running at fast idle, the time to raise the pressure to cutout exceeds 5 minutes.
    - (D) A warning device–audible or visible–does not operate at all pressures at and below 60 psi pressure.
- (5) Check parking brake operation and **REJECT IF** the pedal or lever reaches its limit of travel before the parking brakes are set.
- (6) Check the seat and safety belts, if the vehicle is so equipped and **REJECT IF** one or more of the following apply:
- (i) The driver’s seat or back rest is not firmly attached.
  - (ii) The metal spring protrudes from the driver’s seat.
  - (iii) The seat adjusting mechanism slips out of a set position.
  - (iv) There is no safety belt for each seating location, if the vehicle was originally so equipped, or if seats have been added.
  - (v) The safety belt webbing is frayed.

- (vi) The belt buckles do not operate properly.
- (vii) The belt anchorages are broken.
- (7) Check the inside mirror and **REJECT IF** one or more of the following apply:
  - (i) The mirror is cracked, broken, or discolored.
  - (ii) The mirror will not hold adjustment.
  - (iii) An object or material is hung from or blocking inside mirror.
  - (iv) Mirror is missing, unless the vehicle is equipped with outside mirror, except on school buses.
- (8) Check front windshield defroster system, if so equipped, and reject if the defroster fan does not function.
- (c) Under the Hood Inspection** - An under the hood inspection shall be performed as follows:
  - (1) Check hood and **REJECT IF** any of the following apply:
    - (i) Latch does not hold securely in fully-closed position.
    - (ii) Latch release mechanism or its parts are broken, missing, or so poorly adjusted so that the hood can not be properly closed.
    - (iii) The double latch mechanism is not operating as originally equipped.
  - (2) Check the motor mounts, either here or during beneath vehicle inspection, and **REJECT IF** motor mounts are broken, cracked, or missing.
  - (3) Check air pressure and **REJECT IF** one or more of the following apply:
    - (i) The air pressure relief valve does not operate.
    - (ii) The compressor drive belts are worn, loose or frayed so as to prevent proper operation of the compressor.
    - (iii) Air intake cleaner is clogged so as to prevent proper air intake.
    - (iv) The air compressor has loose mounting bolts.
    - (v) The air compressor has a cracked, broken or loose pulley.
  - (4) Check fuel systems and controls.
    - (i) **REJECT IF** any of the following apply:
      - (A) There is liquid fuel leakage at any point in system.
      - (B) Part of fuel line is not securely fastened.
      - (C) A fuel tank or line was not specifically designed or manufactured as fuel tank or line.
      - (D) A fuel line is in contact with high temperature surfaces or moving parts.
      - (E) The fuel tank or line intrudes into a driver, passenger or cargo compartment, except if the vehicle was originally so equipped.
      - (F) The throttle does not return to the idle position when actuating force is removed.
      - (G) The firewall has holes or cracks which would permit fumes to enter the driver and passenger compartments.
    - (ii) If the vehicle is equipped with an alternate fuel system, see Subchapter M (relating to alternate fuel systems and controls).
  - (5) Check the exhaust system and **REJECT IF** there is an exhaust leak.
  - (6) Check the brake system and **REJECT IF** one or more of the following apply:
    - (i) The master cylinder leaks.
    - (ii) The power brake lines or hydraulic hoses or lines leak or are disconnected, flattened, or restricted.

- (iii) The hydraulic booster for the power brake system is leaking or inoperative or has excessively worn belts that would prevent proper operation of the pump.
  - (iv) The brake hoses seep or swell under application of pressure.
  - (v) The connecting hoses are improperly joined; for example, a splice made by sliding the hose ends over a piece of tubing and clamping the hose to the tube.
- (7) Check the battery and reject if the battery is not securely fastened with a device specifically designed for that function.
- (8) Check steering gear box and reject if loose on frame.
- (d) Beneath the Vehicle Inspection** - A beneath the vehicle inspection shall be performed as follows:
- (1) Inspect the tires and wheels and **REJECT IF** one or more of the following apply:
- (i) A tire has two adjacent treads with less than 2/32-inch tread remaining at any point - less than 4/32-inch tread on front tires of vehicles having gross weight in excess of 10,000 pounds.
  - (ii) The tire is worn so that tread wear indicators contact the road in any two adjacent grooves.
  - (iii) Part of the ply or cord is exposed.
  - (iv) A tire has been repaired with blow-out patch or boot.
  - (v) There is a bump, bulge or separation.
  - (vi) A tire is marked "not for highway use," "for racing purposes only" or "unsafe for highway use," or has a similar designation. This subparagraph is not applicable if the Department has issued a permit under 75 Pa.C.S. §4969 (relating to permit for movement of vehicles with oversized wheels and tires) authorizing the vehicle to be operated with oversize wheels and tires.
  - (vii) There are other conditions or markings reasonably believed to render tire unsafe for highway use.
  - (viii) The front tire on a bus is retreaded or recapped.
  - (ix) A front tire has been regrooved.
  - (x) A tire has been regrooved or recut below the original tread design depth, except a tire which is identified as having extra undertread rubber.
  - (xi) The diameter of one of the duals is not within 3/8 inch of other.
  - (xii) A tire's tread extends beyond the outer edge of the wheel housing, inclusive of fender flares, or exceeds the manufacturer's specifications as to size.
  - (xiii) The tires used on same axle are not the same size or type of construction—bias, belted, radial or snow.
  - (xiv) The wheel nuts or bolts are missing or loose or have improper thread engagement.
  - (xv) The stud or bolt holes are worn out of round.
  - (xvi) Part of wheel is bent, cracked, welded or damaged so as to affect safe operation of vehicle.
  - (xvii) The rear wheel does not track the front wheel in the straight ahead position as originally designed.
  - (xviii) The wheel base on one side differs from the wheel base on other side by more than 1 inch, unless the vehicle's design specifications indicate different left and right wheel base dimensions.
  - (xix) Studded tires are in use after April 15 and before November 1.
  - (xx) Any axle has missing wheels or rims.
  - (xxi) A tire makes contact with the body or chassis.
  - (xxii) A tire smaller than the manufacturer's recommended minimum size or below the manufacturer's recommended load rating.



## Subchapter F - Medium and Heavy Trucks, Buses and School Buses

---

- (2) Inspect the steering system and **REJECT IF** one or more of the following apply:
- (i) Movement at front or rear of a tire is greater than  $\frac{1}{4}$  inch on wheels 16 inches or under, greater than  $\frac{3}{8}$  inch on wheels 17 inches or 18 inches, or greater than  $\frac{1}{2}$  inch on wheels over 18 inches. Make sure any looseness detected is not wheel bearing free play.
  - (ii) The linkage components are not secured with cotter pins or other suitable devices.
  - (iii) The steering stops allow the tire to rub on the frame or the chassis parts.
  - (iv) The front wheels are incapable of being turned to the right and left steering stops without binding or interference.
  - (v) The universal joint is worn, faulty or shows repairs that were obviously welded.
  - (vi) The front axle beam or steering components are cracked or show repairs that were obviously welded.
- (3) Inspect the suspension system and **REJECT IF** one or more of the following apply:
- (i) The ball joint movement is in excess of the manufacturer's specifications.
  - (ii) The shock absorbers are missing.
  - (iii) The shock absorbers mounting bolts or mounts are broken.
  - (iv) The shock absorbers have severe leakage—not slight dampness.
  - (v) The sway or stabilizer bar is missing or broken, if originally equipped.
  - (vi) The coil spring or main leaf spring is broken.
  - (vii) The spring attaching part is loose, badly worn, broken or missing.
  - (viii) The king pin movement is in excess of  $\frac{1}{4}$  inch on rims less than 20 inches in diameter.
  - (ix) The king pin movement is in excess of  $\frac{1}{2}$  inch on rims 20 inches in diameter or larger.
  - (x) A torsion bar spring is broken.
  - (xi) A part of a torque, radius or tracking component assembly or a part used for attaching the same to the vehicle frame or axle is cracked, loose, broken or missing. This subparagraph does not apply to loose bushings in torque or track rods.
  - (xii) The air suspension is leaking or deflated.
- (4) Inspect the floor and **REJECT IF** any of the following apply:
- (i) The floor bed or inner panels have openings which would allow exhaust gases to enter either occupant compartment or trunk.
  - (ii) The floor bed is not sufficient to hold the weight of the driver, passengers and cargo.
- (5) Inspect the vehicle frame and **REJECT IF** one or more of the following apply:
- (i) The vehicle frame is not in solid condition.
  - (ii) The repairs are made with tape, tar paper or cloth, or are made in another temporary manner.
  - (iii) The frame components are missing cracked, rotted, or broken, or are in a deteriorated or dangerous condition.
  - (iv) An adjustable axle assembly has locking pins missing or not engaged.
- (6) Inspect the exhaust system and **REJECT IF** one or more of the following apply:
- (i) The vehicle has no muffler or noise suppressing system or the muffler has external repair.
  - (ii) There are loose or leaking joints.
  - (iii) There are holes, cracks or leaking seams in exhaust system.
  - (iv) There is a muffler cutout or similar device.

- (v) Part of the exhaust system passes through the occupant compartments.
- (vi) The elements are not securely fastened with proper clamps and hangers.
- (vii) The exposed exhaust system does not have an adequate heat shield or protective system.
- (viii) The exhaust does not discharge to the outside edge of the vehicle body, including a truck bed, or as originally designed, except for the following:
  - (A) **Gasoline powered buses, including school buses.** The exhaust system of a bus powered by a gasoline engine shall discharge to the atmosphere at or within 6 inches forward of the rearmost part of the bus.
  - (B) **Buses, including school buses, powered by fuels other than gasoline.** The exhaust system of a bus using fuels other than gasoline shall discharge to the atmosphere either at or within 15 inches forward of the rearmost part of the vehicle; or to the rear of all doors or windows designed to be opened, except windows designed to be opened solely as emergency exits.
- (7) Inspect the braking system and remove at least one front and one opposite rear wheel. It is not necessary to remove the wheel and drum assembly if there is a removable backing plate that allows examination of the brake system. **REJECT IF** one or more of the following apply:
  - (i) The hydraulic hoses or tubing leaks, is flattened, restricted, insecurely fastened or improperly retained; or has exposed cords.
  - (ii) The wheel cylinder leaks, has missing parts or is improperly retained or not functioning.
  - (iii) The caliper leaks, has missing parts or is improperly retained or not functioning.
  - (iv) The lining is broken; not firmly attached to the shoe; or is contaminated with oil, grease, or another substance that would affect proper brake operation.
  - (v) There are leaks in air brake system valves, diaphragms or piston cups.
  - (vi) The drums are scored deeper than .060 inch.
  - (vii) The inside diameter of the drum is greater than the maximum diameter stamped on the drum or greater than .090 inch over the original drum diameter for unmarked drums less than 14 inches, or greater than .120 inch over original drum diameter for unmarked drums 14 inches or larger.
  - (viii) The disc thickness is less than minimum stamped on the assembly or less than the manufacturer's specifications.
  - (ix) The bonded linings are less than 2/32 inch at the thinnest point.
  - (x) The riveted linings are less than 1/32 inch above the rivet head at thinnest point.
  - (xi) The bolted lining is worn to less than 5/16 inch at the center of shoe.
  - (xii) The air pressure relief valve does not operate.
  - (xiii) The air compressor belts are worn, loose or frayed so as to prevent the proper operation of the compressor.
  - (xiv) The air intake cleaner is clogged so as to prevent proper air intake.
  - (xv) There is mechanical damage other than wear.
  - (xvi) A truck or truck-tractor with three or more axles manufactured after October 26, 1986, is not equipped with service brakes on all axles.
  - (xvii) A truck or truck-tractor with three or more axles manufactured between July 24, 1980 and October 27, 1986, is not equipped with service brakes on all axles after February 26, 1988.
  - (xviii) The brake hoses seep or swell under application of pressure.
  - (xix) The connecting hoses are improperly joined; for example, a splice made by sliding the hose ends over a piece of tubing and clamping the hose to the tube.
  - (xx) One or more of the following are mismatched across a motor vehicle steering axle:

- (A) Air chamber size.
- (B) Slack adjuster length.
- (C) Retracted push rod lengths differing by more than 1/2 inch.

(8) Inspect critical body mounts and **REJECT IF** one or more of the following apply:

- (i) Body mounts do not hold as required.
- (ii) A body mount is broken, cracked, deteriorated or missing.

(9) Inspect the fuel system and **REJECT IF** one or more of the following apply:

- (i) There is fuel leakage.
- (ii) Part of system is not securely fastened.
- (iii) The system is not properly routed.

**(e) Road Test** - Perform a road test and **REJECT IF** one or more of the following apply:

- (1) The parking brake fails to exhibit normal resistance when an attempt is made to move the vehicle both forward and backward from a stopped position.
- (2) The automatic transmission will not hold in the park position.
- (3) The vehicle is not capable of stopping within the maximum stopping distance prescribed in Table I or swerves so that any part leaves the 12-foot lane.
- (4) There is a malfunction of braking or steering mechanism—particularly shimmy, wander, pull—or another questionable operating behavior that affects the safe operation of vehicle.
- (5) The speedometer does not operate.
- (6) The odometer does not operate, except a motor vehicle at least 25 years old or a vehicle over 17,000 pounds registered gross weight.
- (7) The vehicle cannot be driven both forward and backward.

## Subchapter G

### RECREATIONAL, SEMI- AND UTILITY TRAILERS

#### 175.121. Application

Equipment standards set forth in this subchapter apply to trailers towed or operated on highways.

#### 175.122. Suspension

Every suspension component shall be in safe operating condition.

#### 175.123. Braking Systems

- (a) **Condition of Braking Systems** - Braking systems and components shall be in safe operating condition as described in §175.130 (relating to inspection procedure).
- (b) **Service Brakes** - A trailer shall be equipped with a service brake system. See 75 Pa.C.S. §4502 (relating to general requirements for braking systems).
- (1) The service brakes shall act on all wheels upon application except for the following:
    - (i) On inter-connected dual wheels, the brakes may act upon only one wheel.
    - (ii) A vehicle being towed in driveaway- towaway operation.
    - (iii) A trailer of a gross weight not exceeding 3,000 pounds, if the gross weight of the trailer does not exceed 40% of the gross weight of the towing vehicle.
  - (2) The service brakes, when required, shall be capable of stopping the vehicle in not more than the maximum stopping distance prescribed in Table I.
  - (3) Surge or inertia type brake systems are authorized.
  - (4) The brake lining and brake fluids shall be of type approved by the vehicle manufacturer or shall meet the Society of Automotive Engineers (SAE) standards (J998 January 1980) see Appendix A (relating to minimum requirements for motor vehicle brake linings-SAE J998).
  - (5) Metal from shoe may not contact brake drums or rotors.
  - (6) A vehicle to which additional axles and wheels have been added shall be equipped with brakes on all the additional wheels.
  - (7) Brake lines shall be approved for use as brake lines.
- (c) **Breakaway System** - A trailer operated on a highway which is equipped with brakes or which has gross weight in excess of 3,000 pounds shall be equipped with a breakaway system which shall stop and hold the vehicle automatically upon breakaway from the towing vehicle.
- (d) **Air Chamber Push Rod** - Air chamber push rod travel may not exceed the manufacturer's specifications maximum stroke allowance. See Chart 4 (relating to brake chamber push rod travel (typical)) for drawing of air chamber push rod.

#### 175.124. Tires and Wheels

- (a) **Condition of Tires and Wheels** - Tires and wheels shall be in safe operating condition as described in §175.130 (relating to inspection procedure).
- (b) **Tire Standards** - A trailer shall have tires that were manufactured in conformance with standards contained in Chapter 159 (relating to new pneumatic tires). See 75 Pa.C.S. §4525, (relating to tire equipment and traction surface). Tires with equivalent metric size designations may be used.
- (c) **Radial Ply Tires** - A radial ply tire may not be used on the same axle with a bias or belted tires.
- (d) **Different Types of Tires** - Tires of different types and sizes, such as one snow tire and one regular tire or bias, belted or radial tires, may not be used on same axle, except in an emergency.
- (e) **Non-Pneumatic Tires** - No trailer operated on a highway shall be equipped with non-pneumatic tires.

## Subchapter G - Recreational, Semi- and Utility Trailers

---

- (f) **Ice Grips or Studs** - A tire may not be equipped with ice grips or tire studs of wear-resisting material which have projections exceeding 2/32 inch beyond the tread of traction surface of the tire.
- (g) **Tires and Rims** - The axles of a vehicle specified under this subchapter shall be equipped with the number and type of tires and rims which have a load rating equal to or higher than those offered by the manufacturer.

### 175.125. Lighting and Electrical Systems

- (a) **Condition of Lamps and Switches** - Every required lamp or switch shall be in safe operating condition as described in §175.130 (relating to inspection procedure).
- (b) **Lighting Standards** - All lamps shall comply with Tables II-IV; Chapter 153 and 75 Pa.C.S. Chapter 43 (relating to lighting equipment).
- (c) **Other Required Lamps** - A trailer shall have at least one red stop lamp on each side of the rear of the vehicle, which shall be illuminated immediately upon application of the service brake.
- (d) **Illumination** - A trailer shall be equipped with parking lamps, stop lamps, tail lamps, turn signal lamps and hazard warning lamps designed for that specific function, which under normal atmospheric conditions, shall be capable of being seen and distinguished during nighttime operation, at a distance of 500 feet. See 75 Pa.C.S. §4303(b)-(d) (relating to general lighting requirements).
  - (1) Stop lamps, turn signals and hazard warning lamps shall be visible at a distance of 100 feet during normal sunlight.
  - (2) Rear lamps shall be lighted whenever headlamps, fog lamps, or auxiliary driving lamps are in operation.
  - (3) A trailer shall be equipped with hazard warning lamps, unless these lamps were not included as original equipment.
  - (4) The turn signals shall have a frequency of flash between 60-120 flashes per minute.
- (e) **Condition and Position of Lamps** - Lamps shall be properly fastened; direct light properly; be of a color not contrary to Tables II-IV (relating to required motor vehicle lighting equipment; location of required equipment and required motor vehicle lighting equipment); and may not be so obstructed by a screen, bar, auxiliary equipment or device of any kind as to obscure, change color of or obstruct the beam.
- (f) **Ornamental Lamps** - A lamp not enumerated in this section, and not located as described in Tables III-V of this chapter is prohibited unless it is available as original equipment. An illuminated sign is prohibited. Flashing or revolving lights are not ornamental lamps. Provisions relating to flashing or revolving lights are located in Chapters 15 and 173 (relating to authorized vehicles and special operating privileges; and flashing or revolving lights on emergency and authorized vehicles).
- (g) **Back-Up Lamps** - Back-up lamps, if the vehicle is so equipped, shall turn off automatically when the vehicle goes forward.
- (h) **Registration Plate Lamp** - A registration plate lamp, if originally equipped, shall emit white light and make the registration plate visible from a distance of 50 feet to rear of vehicle.
- (i) **Trailer** - A trailer that is less than 30 inches in overall width may be equipped with only one of each of the following lamps and reflective devices, located at or near its vertical centerline: tail lamps, stop lamp and rear reflex reflector.

### 175.126. Glazing

- (a) **Condition of Glazing** - Glazing, including rigid plastic, shall meet the requirements of Chapter 161 (relating to glazing materials). See 75 Pa.C.S. §4526 (relating to safety glass).
- (b) **Safety Glazing** - A trailer except house trailers, shall be equipped with safety glazing in all windows and wings. Requirements of this subsection do not apply to a vehicle manufactured or assembled before January 1, 1934, if the original glazing is not cracked or discolored.

### 175.127. Body

- (a) **Condition of Body** - All items on the body shall be in safe operating condition as described in §175.130

(relating to inspection procedure).

- (b) **Protruding Objects** - A trailer shall have no torn metal, glass or other loose or dislocated parts protruding from the body.
- (c) **Doors** - A vehicle specified under this subchapter shall be equipped with doors of a type used as original equipment. The doors shall open and close securely. Tailgates may be replaced with wood planking, nets or other material that will prevent loss of load. Tailgates may be removed when optional equipment is added.

### 175.128. Chassis

- (a) **Condition of Chassis** - All items on the chassis shall be in safe operating condition as described in §175.130 (relating to inspection procedure).
- (b) **Vehicle Frame** - The vehicle frame shall be in solid condition.
- (c) **Flooring and Floor Beds** - Flooring and floor beds shall be of a construction that supports occupants and cargo which the vehicle is capable of carrying, and may not have any openings through which exhaust gases could enter the passenger compartment.
- (d) **Rear Protection Device** - A trailer, except for pole trailers, whose body has a rear end clearance of more than 30 inches from the ground when empty, shall be equipped with a rear bumper or rear end protection device as follows:
  - (1) The rear bumper or rear end protection device shall be:
    - (i) Within 30 inches of ground when the vehicle is empty.
    - (ii) Within 24 inches of another rear bumper or rear end protection device, if more than one rear bumper or rear end protection device is used.
    - (iii) Within 18 inches—transverse distance—of the widest part of the rear of the vehicle.
    - (iv) Within 24 inches of the extreme rear of the vehicle.
    - (v) Substantially constructed and firmly attached.
  - (2) Trailers constructed and maintained so that the body, chassis or other parts of the vehicle afford the rear end protection described in paragraph (1) shall be deemed to be in compliance with this subsection.
- (e) **Fenders and Flaps** - The wheels of a trailer originally manufactured with fenders or flaps shall be equipped with fenders or flaps of a type used as original equipment.
- (f) **Rear Wheel Shields** - A trailer shall be constructed or equipped as to bar water or other road surface substances thrown from the rear wheels of the vehicle or combination at tangents exceeding 22 1/2°, measured from road surface, from passing in a straight line to the rear of the vehicle or combination. See 75 Pa.C.S. §4533 (relating to rear wheel shields).
- (g) **Tire Contact** - A tire may not come in contact with the body, fenders or chassis of the vehicle.

### 175.130. Inspection Procedure

- (a) **External Inspection** - An external inspection of a trailer over 3,000 pounds registered gross weight shall be performed as follows:
  - (1) Verify ownership, legality and proof of financial responsibility. For the purpose of this subchapter, ownership and legality shall be proven by a vehicle registration card, certificate of title or manufacturer's statement of origin. When a vehicle being held for resale is presented for inspection by a dealer licensed to sell vehicles in this Commonwealth, a VIN-specific auction slip or VIN-specific secure power of attorney evidencing the dealership's acquisition of the vehicle, or both, may be presented instead of a vehicle registration card, certificate of title or manufacturer's statement of origin.

**REJECT IF** one or more of the following apply:

- (i) When vehicle ownership and legality are demonstrated by presentation of certificate of title, manufacturer's statement of origin, VIN-specific auction slip or VIN-specific secure power of attorney:

- (A) The VIN is not in agreement with the certificate of title, manufacturer's statement of origin, VIN-specific auction slip or VIN-specific secure power of attorney. Exception: If only one digit is incorrect or two digits are transposed, and the owner provides evidence that the appropriate Department form has been completed to correct the error or transposition.
- (B) The VIN plate is not securely fastened or is defaced, misplaced or missing.
- (ii) When vehicle ownership and legality are demonstrated by presentation of vehicle registration card:
  - (A) The license plate is not in agreement with numbers on vehicle registration card. Exception: If only one digit is incorrect or two digits are transposed, and the owner provides evidence that the appropriate Department form has been completed to correct the error or transposition.
  - (B) The license plate is hanging loosely from its mounting bracket.
  - (C) The license plate is obscured so that the numbers cannot be identified.
  - (D) The license plate lamp, if so equipped, does not illuminate the license plate.
- (iii) A registered vehicle only, if any of the following apply:
  - (A) The license plate is not in agreement with the number on the registration certificate. Exception: If only one digit is incorrect or two digits are transposed, and the owner provides evidence that the appropriate department form has been completed to correct error or transposition.
  - (B) The license plate is hanging loosely from its mounting bracket.
  - (C) The license plate is obscured so that the numbers cannot be identified.
  - (D) The license plate lamp, if so equipped, does not illuminate the license plate.
- (2) Check the glazing and **REJECT IF** any of the following apply:
  - (i) Approved safety glazing or rigid plastic is not used in every window or wing except in house trailers.
  - (ii) The glass or rigid plastic is shattered or broken or has any sharp edges.
  - (iii) A trailer designed for passengers does not have safety glazing or rigid plastic.
- (3) Check door operation, including the tailgate and **REJECT IF** one or more of the following apply:
  - (i) The doors are not on the vehicle if originally fitted by manufacturer.
  - (ii) The doors, including the tailgate, cannot be closed securely.
  - (iii) Tailgate or equivalent is not on the vehicle, unless removed for the addition of optional equipment that is present at the time of inspection.
- (4) Check the lamps and lenses and **REJECT IF** one or more of the following apply:
  - (i) An exterior bulb or sealed beam, if originally equipped or installed, fails to light properly, except ornamental lights.
  - (ii) The turn signal lamps do not flash between 60-120 flashes per minute.
  - (iii) The turn signal lamps do not properly indicate right or left when so switched.
  - (iv) The back-up lamps do not turn off automatically when the vehicle goes forward.
  - (v) The lamp shows a color contrary to law as specified in lighting chart—Tables II - IV (relating to required motor vehicle lighting equipment; location of required equipment; and required motor vehicle lighting equipment).
  - (vi) A lamp or filament indicated at the switch position does not light when the correct switch indicates the lamp should be on.
  - (vii) A lamp has a missing or broken lens.
  - (viii) A required lamp is missing.

- (ix) Auxiliary equipment is placed on, in, or in front of a lamp.
  - (x) Detachable electrical connections are not contained in the cable or cables or entirely within substantially constructed protection device.
- (b) **Internal Inspection** - An internal inspection of a trailer over 3,000 pounds registered gross weight shall be performed as follows:
- (1) Check the flooring and **REJECT IF** any of the following apply:
    - (i) The flooring and floor beds are not in a condition to support cargo.
    - (ii) On passenger-carrying trailers **REJECT IF** any of the following apply:
      - (A) The flooring and floor beds are not substantially constructed to support occupants and cargo. The floor pan is rusted through to cause hazard to occupants or to permit exhaust gases to enter passenger compartment.
      - (B) The step well or floor is cluttered or worn so as to present tripping hazard.
      - (C) The guard rails or grab rails are loose or fastening parts are missing.
      - (D) The emergency exit is not easily accessible.
      - (E) The inside or outside quick release mechanism on emergency doors or windows on passenger-carrying trailer fail to function properly or open accidentally.
- (c) **Beneath the Vehicle Inspection** - A beneath the vehicle inspection of a trailer over 3,000 pounds registered gross weight shall be performed as follows:
- (1) Inspect tires and wheels and **REJECT IF** one or more of the following apply:
    - (i) A tire has two adjacent treads with less than 2/32 inches tread remaining at any point.
    - (ii) The tire is worn so that tread wear indicators contact road in any two adjacent grooves.
    - (iii) Part of the ply or cord is exposed.
    - (iv) A tire has been repaired with blow-out patch or boot.
    - (v) There is a bump, bulge or separation.
    - (vi) The tire is marked "not for highway use," "for racing purposes only" or "unsafe for highway use," or has any similar designation.
    - (vii) There are other conditions or markings reasonably believed to render tire unsafe for highway use.
    - (viii) A tire has been regrooved or recut below original tread design depth.
    - (ix) A tire extends beyond body line, a tire is smaller than the manufacturer's recommended minimum size, or below the manufacturer's recommended load rating or a tire makes contact with the body or chassis.
    - (x) Tires on same axle are not the same size or type of construction—bias, belted, or radial.
    - (xi) The wheel nuts or bolts are missing or loose or have improper thread engagement.
    - (xii) The stud or bolt holes are worn out of round.
    - (xiii) Part of the wheel is bent, cracked, welded or damaged so as to affect safe operation of vehicle.
    - (xiv) Studded tires are in use after April 15 and before November 1.
    - (xv) The diameter of duals is not within 3/8 inch of each other.
    - (xvi) An axle has missing tires or rims.
  - (2) Inspect the vehicle frame and **REJECT IF** one or more of the following apply:
    - (i) The vehicle frame is not in solid condition.
    - (ii) A repair is made with tape, tar paper or cloth or is made in any another temporary manner.
    - (iii) The frame components are missing cracked, rotted, or broken or in deteriorated or dangerous



condition.

- (iv) There is no rear end protrusion which is within 24 inches of the rear of the trailer and within 30 inches of the ground and within 18 inches of each side.
  - (v) Torn metal or other loose or dislocated parts protrude from the surface of body.
  - (vi) The tailgate or doors are broken or sagging so that the doors cannot be tightly closed.
  - (vii) The landing gear parts are broken or missing and the gear is not operating properly.
  - (viii) The rear wheel shields or mud flaps are not mounted properly. Every trailer must be equipped with rear wheel shields to bar water or other substances thrown from rear wheels at tangents exceeding 22 1/2 degrees, measured from road surface, from passing in straight line to rear.
  - (ix) The king pin has excessive wear.
  - (x) There are cracks in the contact area on the 5th wheel plate.
  - (xi) An adjustable axle assembly has locking pins missing or not engaged.
  - (xii) A torsion bar spring is broken.
  - (xiii) A part of a torque, radius or tracking component assembly or a part used for attaching the same to the vehicle frame or axle is cracked, loose, broken or missing. This subparagraph does not apply to loose bushings in torque or track rods.
- (3) Inspect the braking system.
- (i) Inspect braking system and **REJECT IF** one or more of the following apply:
    - (A) The bonded linings are less than 2/32 inch at the thinnest point.
    - (B) The riveted linings are less than 1/32 inch above the rivet head at the thinnest point.
    - (C) The lining on a semi-trailer is less than 5/16 inch at the center of the shoe.
    - (D) The lining is broken; not firmly attached to the shoe; or contaminated with oil, grease or another substance that would affect proper brake operation.
    - (E) There are substantial cracks on the friction surface of a drum extending to an open edge.
    - (F) There is wear to such an extent that the brake cam is on end or cam has turned over.
    - (G) The brake shoe rollers are worn and flattened so as to interfere with brake operation.
    - (H) The air chamber push rod travel exceeds maximum stroke allowance. See Chart 4 (relating to brake chamber push rod travel (typical)) for a drawing of the air chamber push rod.
    - (I) The hydraulic hoses or tubing leaks; is flattened, restricted, insecurely fastened or improperly retained; or has exposed cords.
    - (J) The brake hoses, lines or tubing is leaking, chaffed, restricted, crimped, cracked or broken.
    - (K) The surge brake system is leaking.
    - (L) There is leakage in the lines or cylinders, reservoirs, hydraulic, vacuum or air brake systems.
    - (M) There is no control from the cab of the towing vehicle.
    - (N) The brakes are not equalized to stop the vehicle from swerving when tested in combination with the trailer.
    - (O) The brakes fail to apply automatically on disconnection with the tractor.
    - (P) The surge brake system is defective.
    - (Q) The maximum amperage on the electric brakes is more than 20% above or more than 30% below the brake manufacturers' maximum current rating.
    - (R) All wheels are not equipped with brakes.

(S) The drums are scored deeper than .060 inch.

(T) The brake hoses bulge or swell under application of pressure.

(U) The connecting hoses are improperly joined; for example, a splice made by sliding the hose ends over a piece of tubing and clamping the hose to the tube.

(ii) The brake lining from one side of each axle shall be examined.

(4) Inspect the air suspension system and **REJECT IF** the system is leaking or deflated.

**(d) Road Test** - Perform a road test of a trailer over 3,000 pounds registered gross weight and reject if the vehicle is not capable of stopping within the maximum stopping distance prescribed in Table I or swerves so that any part leaves the 12 foot lane.

## Subchapter H MOTORCYCLES

### 175.141. Application of Subchapter

Equipment standards set forth in this subchapter apply to all motorcycles being driven on highways.

### 175.142. Suspension

- (a) **Condition of Suspension Components** - Every suspension component shall be in safe operating condition as described in §175.160 (relating to inspection procedure).
- (b) **Suspension System** - A motorcycle shall be equipped with a suspension system.
  - (1) A motorcycle shall be equipped with a suspension system on at least the front wheel.
  - (2) The suspension system shall be effective in reducing road shock and shall be designed for the purpose of maximizing the vehicle's stability.

### 175.143. Steering

- (a) **Condition of Steering Components** - The steering assembly and steering mechanism shall be in safe operating condition as described in §175.160 (relating to inspection procedure).
- (b) **Condition of Steering** - A motorcycle shall meet the following specifications in relation to front wheel geometry:
  - (1) Maximum Rake: 45°—Maximum trail: 14 inches positive.
  - (2) Minimum Rake: 20°—Minimum trail: 2 inches positive.
  - (3) Minimum rake and minimum trail are not applicable to three-wheel motorcycles unless the third wheel is derived from a sidecar.
- (c) **Steering Head** - A head shall be provided with a bearing or similar device allowing the steering shaft to turn freely in rotating fashion.
- (d) **Handlebars** - Nothing in this subchapter prohibits a motorcycle from being equipped with a steering wheel instead of handlebars.
  - (1) The handlebars or steering system shall be of a sturdy construction adequate in size and length to provide proper leverage for steering and capable of withstanding a minimum force of 100 pounds applied to each handle grip in any direction.
  - (2) The handlebars or steering system shall be designed so as not to restrict front fork movement and shall be capable of vertical adjustment.
  - (3) The handlebar design shall provide a minimum of 18 inches between ends, after final assembly.
  - (4) The handlebars shall be equipped with grips of non-slip design and materials.

### 175.144. Braking Systems

- (a) **Condition of Braking Systems** - Braking systems and components shall be in safe operating condition as described in §175.160 (relating to inspection procedure).
- (b) **Service Brakes** - A motorcycle shall be equipped with a service brake system. See 75 Pa.C.S. §4502 (relating to general requirements for braking systems).
  - (1) The service brakes shall act on all wheels upon application and shall be capable of stopping the vehicle in not more than the maximum stopping distance prescribed in Table I (relating to brake performance).
  - (2) The service brake system shall act upon all wheels according to the vehicle manufacturer's specifications, except on a vehicle being towed in driveaway-towaway operation or side cars not originally equipped.

- (3) The brake lining and brake fluids shall be of type approved by vehicle manufacturer or shall meet the Society of Automotive Engineers (SAE) standards (J998 January 1980) see Appendix A (relating to minimum requirements for motor vehicle brake linings - SAE J998).
- (4) The service brake system shall be of a design that rupture or failure of either the front or rear brake system will not result in the complete loss of braking function. Braking function may be obtained by hydraulic or other means through normal brake mechanism. In the event of rupture or failure of actuating force component, the unaffected brakes shall be capable of applying adequate braking force to vehicle.
- (5) Metal from the shoe or caliper shall not contact brake drums or rotors.
- (6) Brake lines shall be approved for use as brake lines.

### 175.145. Tires and Wheels

- (a) **Condition of Tires and Wheels** - Tires and wheels shall be in safe operating condition as described in §175.160 (relating to inspection procedure).
- (b) **Tire Standards** - A motorcycle shall have tires that were manufactured in conformance with standards contained in Chapter 159 (relating to new pneumatic tires). See 75 Pa.C.S. §4525 (relating to tire equipment and traction surfaces). Tires with equivalent metric size designations may be used.
- (c) **Non-Pneumatic Tires** - A motorcycle operated on a highway may not be equipped with nonpneumatic tires.
- (d) **Ice Grips or Stud** - A tire may not be equipped with ice grips or tire studs of wear-resisting material which have projections exceeding 2/32 inch beyond the tread of the traction surface of the tire.
- (e) **Antique Vehicle Pneumatic Tire Exemption** - An antique vehicle may be equipped with nonpneumatic tires if originally equipped by the manufacturer.

### 175.146. Lighting and Electrical Systems

- (a) **Condition of Lamps and Switches** - Every required lamp or switch shall be in safe operating condition as described in §175.160 (relating to inspection procedure).
- (b) **Lighting Standards** - Lamps shall comply with the vehicle lighting equipment requirements of Tables II, IV, and V; Chapter 153; and 75 Pa.C.S. §4301.
- (c) **Headlamp System** - A motorcycle driven on a highway shall have at least one and no more than two headlamps. See 75 Pa.C.S. §4303(a) (relating to general lighting requirements).
  - (1) Lamps in the headlamp system shall be of Type I or Type II construction. On one-lamp system, the lamp shall be located in the center of vehicle. On a two-lamp system, the lamps shall be symmetrically located on each side of the vehicle's vertical centerline.
  - (2) The headlamp low beam minimum candlepower shall not be less than 7,500.
  - (3) The headlamp high beam minimum candlepower shall not be less than 10,000.
  - (4) Every headlamp shall be aimed to comply with inspection procedure of this subchapter.
  - (5) Approved SAE modulating lamps are legal.
  - (6) A motorcycle shall be equipped with a manual dimmer switch conveniently located for use by the driver while in a normal operating position. An automatic dimming device may be used in addition to a manual switch.
  - (7) A motorcycle shall be equipped with a beam indicator which shall be lighted whenever the high beam of light from the headlamp is in use and shall not otherwise be lighted. The indicator shall be so located that when lighted it is readily visible without glare to the operator of the vehicle.
- (d) **Total Candlepower** - Total candlepower for headlamps and auxiliary lamps shall not exceed 150,000.
- (e) **Other Required Lamps** - A motorcycle shall have at least one red stop lamp, and no more than two—one on each side—on the rear of the vehicle, which shall be illuminated immediately upon application of the service brake.

- (f) **Illumination except Headlamps, Fog Lamps, and Auxiliary Driving Lamps** - A motorcycle shall have a stop lamp and tail lamp which, under normal atmospheric conditions, shall be capable of being seen and distinguished during night time operation at a distance of 500 feet. See 75 Pa.C.S. §4303(b) and (d).
- (1) Rear lamps shall be lighted whenever headlamps, fog lamps, or auxiliary driving lamps are in operation.
  - (2) A vehicle specified under this subchapter may be equipped with turn signals.
  - (3) The turn signals shall have frequency of flash between 60-120 flashes per minute.
  - (4) The stop lamps shall be operated through a switching arrangement so that any motion of brake towards applied position immediately illuminates the stop lamp.
  - (5) The stop lamps shall not be combined with turn signal lamps unless arrangement of switches or other parts are such that the stop lamp is extinguished when turn signal is in use.
  - (6) The stop lamps shall be visible for 100 feet in normal sunlight.
  - (7) A motorcycle manufactured after 1978 shall be equipped with alternator, generator, or electrical energy storage source, capable of providing lighting in compliance with Chapter 153 (relating to lamps, reflective devices, and associated equipment) and SAE J392-Appendix B (relating to motorcycle and motor vehicle cycle electrical system [maintenance of design voltage]-SAE J392) - Maintenance of Design Voltage.
  - (8) A motorcycle shall be equipped with at least one red reflector to the rear.
  - (9) A motorcycle shall have at least one tail lamp if it was manufactured after 1973 or if originally so equipped.
- (g) **Condition and Position of Lamps** - Lamps shall be properly fastened; direct light properly; be of a color not contrary to Tables II, IV, and V; and not be so obstructed by a screen, bar, auxiliary equipment, or a device as to obscure, change the color of or obstruct the beam.
- (h) **Ornamental Lamps** - A lamp not enumerated in this section, and not located as described in Tables III - V of this chapter, is prohibited unless it is available as original equipment or is auxiliary lighting added to a motorcycle to protect the driver as permitted by 75 Pa.C.S. § 4310 (related to motorcycle lighting). An illuminated sign is prohibited. Flashing or revolving lights are not ornamental lamps. Provisions relating to flashing or revolving lights are located in Chapters 15 and 173 (relating to authorized vehicles and special operating privileges; and flashing or revolving lights on emergency and authorized vehicles).
- (i) **[Reserved]**.
- (j) **Registration Plate Lamp** - A registration plate lamp, if originally equipped, shall emit white light and make registration plate visible from a distance of 50 feet to the rear of the vehicle.
- (k) **Auxiliary Driving Lamps and Fog Lamps** - Auxiliary driving lamps and fog lamps may be installed on a motorcycle if they comply with the following requirements:
- (1) Fog lamps shall not be substituted for headlamps, except under conditions of rain or fog. Fog lamps may be used with lower headlamp beams.
  - (2) Auxiliary driving lamps and fog lamps shall be mounted on front at a height not less than 12 inches nor more than 42 inches above level surface upon which the vehicle stands. Rear fog lamps, if originally installed or offered as optional equipment, are acceptable.
  - (3) Auxiliary lamps and fog lamps shall be aimed when the vehicle and lamp assembly are in the straight ahead position with the beam not above the horizontal centerline of the lamp at 25 feet.
  - (4) A motorcycle may have one and no more than two approved auxiliary driving lamps and fog lamps.
  - (5) Auxiliary driving lamps and fog lamps shall not be placed in front of any required lamp.
  - (6) A vehicle equipped with headlamps, auxiliary driving lamps, or fog lamps may not have more than four forward projecting lamps illuminated at the same time.
- (l) **Antique Vehicle Lighting Exemption** - An antique vehicle, if operated exclusively between the hours of sunrise to sunset and not during periods of reduced visibility or insufficient illumination, is exempt from requirements of this section, except requirements pertaining to stop lamps.

- (m) **Battery Fastening** - A vehicle specified under this subchapter shall be equipped with a system which is specifically designed for the secure fastening of the battery.

### 175.147. Glazing

- (a) **Condition of Glazing** - Glazing shall meet the requirements of Chapter 161 (relating to glazing materials). See 75 Pa.C.S. §4526 (relating to safety glass).
- (b) **Safety Glazing** - A motorcycle may be equipped with a windscreen. This subsection does not apply to a vehicle manufactured or assembled before January 1, 1934, if original glazing is not cracked or discolored.
- (c) **Stickers** - Out-of-state inspection stickers, tax stamps, road use permits, or other government-related permits—all municipalities and states—may be placed at lower left or right-hand corner of the windscreen.
- (d) **Obstructions** - A vehicle specified under this subchapter shall have glazing free from obstructions as described in §175.160 (relating to inspection procedure).
- (1) With the exception of the materials in paragraph (3), signs, posters or other materials, whose design prevents a driver from seeing through the material, may not be placed on the windscreen or a side wing or side window so as to obstruct, obscure or impair the driver's clear view of the highway or an intersecting highway. Under FMVSS No. 205, these restrictions do not apply to the rear side windows, rear wings or rear window of vehicles subject to this subchapter, if so equipped.
  - (2) The requirements of this subsection also apply to glass etchings, except those used for vehicle identification.
  - (3) A sun screening device or other material which does not permit a person to see or view the inside of the vehicle is prohibited unless otherwise permitted by FMVSS No. 205, or a certificate of exemption has been issued in compliance with §175.265 (relating to exemption provisions). See Table X for specific requirements for vehicles subject to this subchapter.

### 175.148. Mirrors

- (a) **Condition of Mirrors** - Mirrors shall be in safe operating condition as described in §175.160 (relating to inspection procedure).
- (b) **Rearview Mirrors** - A motorcycle shall be equipped with at least one rearview mirror or similar device. If a certificate of exemption for a sun screening device or other material has been issued, rearview mirrors, each with a minimum reflective surface of 12 1/2 square inches for a flat mirror or 10 square inches for a convex mirror, shall be installed on both sides of a motorcycle. A vehicle for which a certificate of exemption has been issued for medical reasons may be equipped with only a left outside rearview mirror, unless originally equipped with an outside rearview mirror on both sides of the vehicle.
- (1) A mirror may not be cracked, broken or discolored.
  - (2) A mirror shall hold adjustment.
  - (3) A mirror shall provide an unobstructed view of the highway to the rear of the vehicle for distance of not less than 200 feet.
  - (4) A mirror shall provide a minimum reflective surface of 12 1/2 square inches for a flat mirror or 10 square inches for a convex mirror.
- (c) **Obstructions** - A motorcycle rearview mirror shall be free from obstructions as described in §175.160.

### 175.149. Fuel Systems

- (a) **Condition of Fuel Systems** - All components in the fuel system shall be in safe operating condition as described in §175.160 (relating to inspection procedure).
- (b) **Fuel System Requirements** - The fuel system components shall be leakproof and shall be fastened securely to the vehicle with fasteners designed for that purpose.
- (c) **Accelerator Operation** - The accelerator control system shall return the engine throttle to the idle position when the operator removes the actuating force from the accelerator control.

## Subchapter H - Motorcycles

---

- (d) **Filler Cap** - The fuel system shall be equipped with a filler cap.
- (e) **Alternate Fuel Systems** - See Subchapter M (relating to alternate fuel systems and controls).

### 175.150. Speedometers

Every motorcycle shall have an operating speedometer calibrated to indicate miles per hour or kilometers per hour.

### 175.151. Odometers

Every motorcycle shall have an operating odometer calibrated to indicate total miles or kilometers driven, except motorcycles at least 25 years old.

### 175.152. Exhaust Systems

- (a) **Condition of Exhaust System** - All components of the exhaust system shall be in safe operating condition as described in §175.160 (relating to inspection procedure).
- (b) **Exhaust System Requirements** - A motorcycle shall be equipped with a muffler or other effective noise-suppressing system in good working order and in constant operation. A muffler or exhaust system may not be equipped with a cutout, bypass or similar device and a muffler may not show evidence of external repair.
  - (1) The exhaust system of a motorcycle may not be modified in a manner which will amplify or increase noise emitted by the motor of the vehicle above the maximum level permitted by Chapter 157 (relating to established sound levels).
  - (2) An exposed exhaust systems shall be equipped with adequate heat shield or protective system or be located to prevent contact by operator or passenger.

### 175.153. Horns and Warning Devices

- (a) **Condition of Horns and Warning Devices** - All components of the horn or warning device shall be in safe operating condition as described in §175.160 (relating to inspection procedure).
- (b) **Horn and Warning Device Requirements** - A motorcycle shall have a horn or other warning device which is audible under normal conditions at a distance of not less than 200 feet. No vehicle shall be equipped with a siren, bell, whistle or similar device emitting an unreasonably loud or harsh sound, except emergency vehicles and vehicles equipped with an anti-theft device.

### 175.154. Body

- (a) **Condition of Body** - All items on the body shall be in safe operating condition as described in §175.160 (relating to inspection procedure).
- (b) **Fenders** - The wheels of a motorcycle shall be equipped with fenders of a type used as original equipment. At no time shall tires come in contact with the body, fenders or chassis of the vehicle.
- (c) **Protruding Objects** - A motorcycle shall have no torn metal, glass or other loose or dislocated parts protruding from body.

### 175.155. Chassis

- (a) **Condition of Chassis** - All items on the chassis shall be in safe operating condition as described in §175.160 (relating to inspection procedure).
- (b) **Vehicle Frame** - A vehicle frame shall be in solid condition.
- (c) **Seats** - A motorcycle shall be equipped with a seat for the operator which is firmly anchored to the frame or support. No metal spring shall protrude from the driver's seat.
- (d) **Chain guard or Drive Shaft Cover** - A covering device to prevent contact with a rider while in a normal riding position must be provided.
- (e) **Stands** - A motorcycle stand shall operate and be strong enough to support the vehicle and stay in the proper position when not holding the bike in standing position.

- (f) **Hand-Hold** - A hand-hold device shall be provided if the motorcycle is designed to carry more than one person.
- (g) **Footrests** - A motorcycle operated or driven upon highway shall have footrests for each person operating or riding upon the vehicle.
- (h) **Highway Bars** - If the motorcycle is so equipped, highway bars shall have a maximum width of 26 inches and shall be located less than 15 inches from the foot controls and shall not interfere with the operation of foot controls.

### 175.160. Inspection Procedure

- (a) **External Inspection** - An external inspection shall be performed as follows:
  - (1) Verify ownership, legality and proof of financial responsibility. For the purpose of this subchapter, ownership and legality shall be proven by a vehicle registration card, certificate of title or manufacturer's statement of origin. When a vehicle being held for resale is presented for inspection by a dealer licensed to sell vehicles in this Commonwealth, a VIN-specific auction slip or VIN-specific secure power of attorney evidencing the dealership's acquisition of the vehicle, or both, may be presented instead of a vehicle registration card, certificate of title or manufacturer's statement of origin. **REJECT IF** one or more of the following apply:
    - (i) When vehicle ownership and legality are demonstrated by presentation of certificate of title, manufacturer's statement of origin, VIN-specific auction slip or VIN-specific secure power of attorney:
      - (A) The VIN is not in agreement with the certificate of title, manufacturer's statement of origin, VIN-specific auction slip or VIN-specific secure power of attorney. Exception: If only one digit is incorrect or two digits are transposed, and the owner provides evidence that the appropriate Department form has been completed to correct the error or transposition.
      - (B) The VIN plate is not securely fastened or is defaced, misplaced or missing.
    - (ii) When vehicle ownership and legality are demonstrated by presentation of vehicle registration card:
      - (A) The license plate is not in agreement with the numbers on the vehicle registration card. Exception: If only one digit is incorrect or two digits are transposed, and the owner provides evidence that the appropriate Department form has been completed to correct an error or transposition.
      - (B) The license plate is hanging loosely from its mounting bracket.
      - (C) The license plate is obscured so that the numbers cannot be identified.
      - (D) The license plate lamp, if so equipped, does not illuminate the license plate.
    - (iii) Acceptable proof of financial responsibility is not provided. For the purpose of this chapter, financial responsibility shall be proven by one of the following documents:
      - (A) A valid financial responsibility identification card issued in accordance with 31 Pa. Code (relating to insurance).
      - (B) The declaration page of a valid insurance policy.
      - (C) A valid self-insurance identification card.
      - (D) A valid binder of insurance issued by an insurance company licensed to sell motor vehicle liability insurance in this Commonwealth.
      - (E) A valid insurance policy issued by an insurance company licensed to sell motor vehicle liability insurance in this Commonwealth.
  - (2) Check the Glazing.
    - (i) **REJECT IF** one or more of the following apply:
      - (A) Approved safety glazing is not used in the windscreen.



- (B) A sign, poster or other material whose design prevents a driver from seeing through the material, obstructs, obscures or impairs the driver's clear view of the highway or an intersecting highway.
  - (C) A vehicle displays a sticker other than those prescribed under §175.147(c) (relating to glazing), or displays a parking sticker in a location described in §175.147(d).
  - (D) The glass is shattered, broken or has any exposed sharp edges.
  - (E) There are defects in an acute area of the windshield—center of the critical area on the driver's side of the vehicle directly in the driver's normal line of vision, 8 1/2 inches wide and 5 1/2 inches high—or discolorations or hazardous cracks which would interfere with the driver's vision.
- (ii) This paragraph does not prohibit the use of a product or material along the top edge of the windshield as long as the product or material is transparent and does not encroach upon the AS-1 portion of the windshield as provided by FMVSS No. 205, and the product or material is not more than 3 inches from the top of the windshield.
- (3) Check mirrors and **REJECT IF** one or more of the following apply:
- (i) The mirror is cracked, broken, or discolored.
  - (ii) The mirror will not hold adjustment.
  - (iii) The mirror does not provide a minimum reflective surface of 12 1/2 square inches for a flat mirror or 10 square inches for a convex mirror.
  - (iv) Outside rearview mirrors, with a minimum reflective surface as described in §175.148(b) (relating to mirrors), are not installed on both sides of the motorcycle, if a certificate of exemption for a sun screening device or other material has been issued by the Department. See §175.264 (relating to mirrors). A vehicle for which a certificate of exemption has been issued for medical reasons may be equipped with only a left outside rearview mirror, unless originally equipped with an outside rearview mirror on both sides of the vehicle.
- (4) Check the fenders and **REJECT IF** any of the following apply:
- (i) A fender—front or rear—has been removed.
  - (ii) A fender is not of a type and size used as original equipment.
- (5) Check the flooring and floor beds if applicable and **REJECT IF** any of the following apply:
- (i) The flooring or floor beds are not in a condition constructed to support occupants and cargo.
  - (ii) The floor pan is rusted through so as to cause a hazard to occupants or to permit exhaust gases to enter passenger compartment.
- (6) Check the lamps and lenses and **REJECT IF** one or more of the following apply:
- (i) An exterior bulb or sealed beam, if originally equipped or installed, fails to light properly, except ornamental lights.
  - (ii) The turn signal lamps do not flash between 60-120 flashes per minute.
  - (iii) The turn signal lamps do not properly indicate right or left, when so switched.
  - (iv) The lamp shows a color contrary to Tables IV or V (relating to required motor vehicle lighting equipment; and location of required equipment), as applicable.
  - (v) The lamp or filament indicated at switch position does not light when the correct switch indicates the lamp should be on.
  - (vi) The lamp has a missing or broken lens.
  - (vii) A required lamp is missing.
  - (viii) Auxiliary equipment is placed on, in, or in front of any lamp.
  - (ix) The fog lamps operate with the high beams of headlamps.

- (x) Auxiliary driving lamps operate with the low beam of the standard headlamp system or alone.
- (xi) The headlamps are out of adjustment as follows:
  - (A) Mechanical aimer, if any of the following apply:
    - (I) Horizontal aim is more than 4 inches to the left or right.
    - (II) Vertical aim is higher or lower than 4 inches from the center.
  - (B) Screen or photo electric type tester. See charts 1-3 (relating to aiming screen distance and marking identification; high beam inspection limits and low beam inspection limits).
    - (I) Turn the lamps on high beam and **REJECT IF** the center of the beam is horizontally more than 4 inches to the right or left of straight ahead or if the center of the light beam is vertically more than 4 inches above or below the horizontal line.
    - (II) Turn the lamps on low beam and **REJECT IF** the upper edge of beam is more than 4 inches above or below the horizontal center line of the headlamp or if the inner edge of the beam is more than 4 inches to the right or left of the vertical line.
- (7) Check for protruding metal and **REJECT IF** torn metal, glass or other loose or dislocated parts protrude from the surface of the vehicle so as to create a hazard.
- (8) Check the fuel tank cap and **REJECT IF** the fuel tank filler cap is missing.
- (b) Internal Inspection** - An internal inspection shall be performed as follows:
  - (1) Check the high beam and turn signal indicator lamps and **REJECT IF** the indicator lamps are not working.
  - (2) Check the horn and **REJECT IF** any of the following apply:
    - (i) There is no horn or other acceptable audible warning device.
    - (ii) The horn or other warning device is not audible under normal conditions for a distance of not less than 200 feet.
    - (iii) The vehicle is equipped with a siren, bell, whistle or a device emitting harsh or unreasonably loud sound, except on emergency vehicles and vehicles equipped with an anti-theft device.
  - (3) Check the brake system by doing visual inspection. If the vehicle is equipped with view ports or mechanical brake wear indicators, wheels do not have to be pulled but the mechanic shall determine if lining should be replaced. **REJECT IF** one or more of the following apply:
    - (i) Brake control travel exceeds 80% of total available travel.
    - (ii) Brake control fades while the vehicle is stopped.
    - (iii) There is excessive friction in the control linkage or components or control levers are misaligned or improperly positioned.
    - (iv) The drums or rotors are scored deeper than .015 inch.
    - (v) There is mechanical damage other than wear.
    - (vi) The inside diameter of the drum is greater than the maximum diameter stamped on the drum or greater than .090 inch over the original drum diameter for unmarked drums.
    - (vii) The disc thickness is less than the minimum stamped on assembly or less than the manufacturer's specifications.
    - (viii) The bonded linings are less than 1/32 inches at the thinnest point.
    - (ix) The riveted linings are less than 1/32 inches above the rivet head at the thinnest point.
    - (x) The lining is broken; not firmly attached to the shoe; or contaminated with oil, grease or another substance that would affect proper brake operation.
    - (xi) The master cylinder leaks.
    - (xii) The hydraulic hoses or lines leak or are disconnected, flattened or restricted.

## Subchapter H - Motorcycles

---

- (xiii) The hydraulic booster for the power brake system is leaking or inoperative or has excessively worn belts.
- (xiv) Mechanical indicator shows that pads should be replaced.
- (4) Check the motor mounts and **REJECT IF** motor mounts are broken, cracked or missing.
- (5) Check the fuel systems and controls and **REJECT IF** any of the following apply:
  - (i) There is liquid fuel leakage at any point in the system.
  - (ii) Part of the fuel line is not securely fastened.
  - (iii) A fuel tank or line was not specifically designed or manufactured as fuel tank or line.
  - (iv) A fuel line is in contact with a high temperature surface or moving part.
  - (v) The fuel tank or line intrudes into a driver, passenger or cargo compartment, except if the vehicle was originally so designed. If the vehicle is equipped with an alternate fuel system, see Subchapter M (relating to alternate fuel systems and controls).
  - (vi) The throttle does not return to the idle position when the actuating force is removed.

**(c) Beneath the Vehicle Inspection** - A beneath the vehicle inspection shall be performed as follows:

- (1) Inspect the tires and wheels and **REJECT IF** one or more of the following apply:
  - (i) A tire has two adjacent treads with less than 2/32 inches tread remaining at any point.
  - (ii) A tire is worn so that tread wear indicators contact the road in any two adjacent grooves.
  - (iii) Part of the ply or cord is exposed.
  - (iv) A tire has been repaired with blow-out patch or boot.
  - (v) There is a bump, bulge or separation.
  - (vi) A tire is marked "not for highway use," "for racing purposes only," or "unsafe for highway use," or has a similar designation.
  - (vii) There are other conditions or markings reasonably believed to render a tire unsafe for highway use.
  - (viii) A tire has been regrooved or recut.
  - (ix) The wheel nuts or bolts are missing or loose or have improper thread engagement.
  - (x) The stud or bolt holes are worn out of round.
  - (xi) Part of the wheel is bent, cracked, welded or damaged so as to affect safe operation of vehicle.
  - (xii) The rear wheel does not track front wheel track in the straight ahead position within 1 inch to either side, except for three-wheeled vehicles which must track as originally designed.
  - (xiii) Studded tires are in use after April 15 and before November 1.
  - (xiv) A tire extends beyond body line, any tire is smaller than the manufacturer's recommended minimum size or below the manufacturer's recommended load rating or a tire makes contact with the body or chassis.
- (2) Inspect the steering system and **REJECT IF** one or more of the following apply:
  - (i) The front wheel geometry of a motorcycle with a single front wheel does not meet the following specifications as to rake and trail:
    - (A) Maximum rake: 45 degrees; maximum trail: 14 inches positive.
    - (B) Minimum rake: 20 degrees; minimum trail: 2 inches positive.
  - (ii) The handlebars or steering system of each motorcycle are not of sturdy construction.
  - (iii) The handlebars or steering system restrict front fork movement.
  - (iv) The handlebars do not provide a minimum of 18 inches between grip ends. If equipped with a steering wheel instead of handlebars, the steering wheel, except if specially designed for

handicapped drivers, is not circular or equivalent in strength to original equipment or has an outside diameter less than 13 inches.

- (v) The handlebars are not equipped with grips of non-slip design and material.
- (vi) The measured movement at the front or rear of the tire is greater than 1/4 inch in relation to the axle shaft.
- (vii) The linkage components are not secured with cotter pins or other suitable devices.
- (viii) The steering stops allow a tire to rub on the frame or chassis parts.
- (ix) The front wheel is incapable of being turned to the right and left steering stops without binding or interference.

(3) Inspect the suspension system and **REJECT IF** any of the following apply:

- (i) The shock absorbers are missing.
- (ii) The shock absorber's mounting bolts or mounts are broken.
- (iii) The shock absorbers have severe leakage—not slight dampness.
- (iv) The vehicle continues free rocking after release, indicating loss of the shock absorber function.

(4) Inspect the vehicle frame and **REJECT IF** any of the following apply:

- (i) The vehicle frame is not in solid condition.
- (ii) A repair is made with tape, tar paper or cloth or is made in another temporary manner.
- (iii) The frame components are missing cracked, rotted, or broken or are in deteriorated or dangerous condition.
- (iv) The chain guard or other covering device is missing.
- (v) The motorcycle stand does not operate or is not strong enough to support the vehicle.
- (vi) A hand-hold device is not provided if the motorcycle is designed to carry more than one person.
- (vii) Footrests are not provided for each person operating or riding upon vehicle.
- (viii) The highway bars exceed maximum width of 26 inches or are located more than 15 inches from the foot controls.

(5) Inspect the exhaust system and **REJECT IF** one or more of the following apply:

- (i) The vehicle has no muffler or muffler has external repair.
- (ii) There are loose or leaking joints.
- (iii) There are holes, cracks or leaking seams in exhaust system.
- (iv) There is a muffler cutout or similar device.
- (v) Part of the exhaust system passes through the occupant compartment.
- (vi) The elements are not securely fastened with proper clamps and hangers.
- (vii) The exposed exhaust system does not have an adequate heat shield or protective system or is not located to prevent contact with riders.

(6) Check the battery and **REJECT IF** the battery is not securely fastened.

**(d) Road Test** - Perform road test and **REJECT IF** one or more of the following apply:

- (1) The vehicle is not capable of stopping within the maximum stopping distance prescribed in Table I (relating to brake performance).
- (2) There is a malfunction of the braking or steering mechanism - particularly shimmy, wander and pull—or another questionable operating behavior that affects safe operation of vehicle.
- (3) The speedometer does not operate.

## Subchapter H - Motorcycles

---

- (4) The odometer does not operate except on motorcycles at least 25 years old.
- (5) The vehicle cannot be driven forward.

## Subchapter J

### MOTOR-DRIVEN CYCLES AND MOTORIZED PEDALCYCLES

#### 175.171. Application

Equipment standards set forth in this subchapter apply to all motor-driven cycles and motorized pedalcycles driven on highways.

#### 175.172. Steering

- (a) **Condition of Steering Components** - The steering assembly and steering mechanism shall be in safe operating condition as described in §175.190 (relating to inspection procedure).
- (b) **Steering Head** - The steering head shall be provided with a bearing or similar device allowing the steering shaft to turn freely in a rotating fashion.
- (c) **Handlebars** - Nothing in this subchapter prohibits a motor-driven cycle or pedalcycle from being equipped with a steering wheel instead of handlebars.
  - (1) The handlebars or steering system shall be of a sturdy construction adequate in size and length to provide proper leverage for steering and capable of withstanding a minimum force of 100 pounds applied to each handle grip in any direction.
  - (2) The handlebars or steering system shall be designed so as not to restrict front fork movement and shall be capable of vertical adjustment.
  - (3) The handlebar design shall provide a minimum of 18 inches between ends, after final assembly.
  - (4) The handlebars shall be equipped with grips of nonslip design and materials.

#### 175.173. Braking Systems

- (a) **Condition of Braking Systems** - Braking systems and components shall be in safe operating condition as described in §175.190 (relating to inspection procedure).
- (b) **Service Brakes** - A vehicle specified under this subchapter shall be equipped with a service brake system. See 75 Pa.C.S. §4502 (relating to general requirements for braking systems).
  - (1) The service brakes shall act on all wheels upon application and shall be capable of stopping the vehicle in not more than the maximum stopping distance prescribed in Table I.
  - (2) A service brake system shall act upon all wheels according to the vehicle manufacturer's specifications, except on a vehicle being towed in driveaway-towaway operation or side cars not originally equipped.
  - (3) The brake lining and brake fluids shall be of type approved by the vehicle manufacturer or shall meet the Society of Automotive Engineers (SAE) standards (J998 January 1980). See Appendix A (relating to minimum requirements for motor vehicle brake linings-SAE J998).
  - (4) A vehicle specified under this subchapter shall be equipped with a service brake system of a design that rupture or failure of either the front or rear brake system will not result in the complete loss of braking function. Braking function may be obtained by hydraulic or other means through normal brake mechanism. In the event of a rupture or failure of an actuating force component, the unaffected brakes shall be capable of applying an adequate braking force to vehicle.
  - (5) Metal from the shoe or caliper shall not contact the brake drums or rotors of the cycle if so equipped.

#### 175.174. Tires and Wheels

- (a) **Condition of Tires and Wheels** - Tires and wheels shall be in safe operating condition as described in §175.190 (relating to inspection procedure).
- (b) **Tire Conditions** - The tires may not bear a marking or condition which may render the tire unsafe for highway use. The tires must be free of partial exposure of ply or cord; blow-out patches; bumps, bulges or separation; and regrooving and recutting below the original tread design depth.

## Subchapter J - Motor-Driven Cycles and Motorized Pedalcycles

---

- (c) **Tire Standards** - A vehicle specified under this subchapter shall have tires manufactured in conformance with standards in Chapter 159 (relating to new pneumatic tires). See 75 Pa.C.S. § 4525 (relating to tire equipment and traction surfaces). Tires with equivalent metric size designations may be used.
- (d) **Non-Pneumatic Tires** - No vehicle specified under this subchapter operated on highway shall be equipped with non-pneumatic tires.
- (e) **Ice Grips or Studs** - No tire shall be equipped with ice grips or tire studs of wear-resisting material which have projections exceeding 2/32 inch beyond the tread of the traction surface of the tire.
- (f) **Antique Vehicle Pneumatic Tire Exemption** - An antique vehicle may be equipped with non-pneumatic tires if originally equipped by the manufacturer.
- (g) **Wheel Conditions** - The wheels shall conform to the manufacturer's specifications and shall not be bent, cracked, welded or damaged so as to affect safe operating conditions. The wheels shall be free of missing and loose studs and bolts or an improper thread engagement.

### 175.175. Lighting and Electrical Systems

- (a) **Condition of Lamps and Switches** - Every required lamp or switch shall be in safe operating condition as described in §175.190 (relating to inspection procedure).
- (b) **Lighting Standards** - A vehicle specified under this subchapter driven on highways shall have lamps which comply with Tables II, IV, and V; Chapter 153; and 75 Pa.C.S. §4301.
- (c) **Headlamp System** - A vehicle specified under this subchapter driven on the highway shall have at least one and no more than two headlamps. See 75 Pa.C.S. §4303(a) (relating to general lighting requirements).
  - (1) Lamps in a headlamp system shall be of Type I or Type II construction. On one-lamp system, the lamp shall be located in the center of the vehicle. On two lamp system, the lamps shall be symmetrically located on each side of the vehicle's vertical centerline.
  - (2) The headlamp low beam minimum candlepower shall not be less than 7,500.
  - (3) The headlamp high beam minimum candlepower shall not be less than 10,000.
  - (4) Every headlamp shall be aimed to comply with §175.190.
  - (5) Approved SAE modulating lamps are legal.
  - (6) A vehicle specified under this subchapter shall be equipped with a manual dimmer switch conveniently located for use for the driver while in a normal operating position. An automatic dimming device may be used in addition to a manual switch.
  - (7) A vehicle specified under this subchapter shall be equipped with a beam indicator, which shall be lighted whenever the high beam of light from the headlamp is in use, and shall not otherwise be lighted. The indicator shall be so located that when lighted it is readily visible without glare to the operator of the vehicle.
- (d) **Total Candlepower** - Total candlepower for headlamps and auxiliary lamps shall not exceed 150,000.
- (e) **Other Required Lamps** - A vehicle specified under this subchapter shall have at least one red stop lamp and no more than two stop lamps—one on each side—on the rear of the vehicle, which shall be illuminated immediately upon application of the service brake.
- (f) **Illumination except Headlamps, Fog Lamps, and Auxiliary Driving Lamps** - A vehicle specified under this subchapter shall have a stop lamp and tail lamp which, under normal atmospheric conditions, shall be capable of being seen and distinguished during night time operation at a distance of 500 feet. See 75 Pa.C.S. §4303(b) and (d).
  - (1) Rear lamps shall be lighted whenever headlamps, fog lamps or auxiliary driving lamps are in operation.
  - (2) A vehicle specified under this subchapter may be equipped with turn signals.
  - (3) The turn signals shall have frequency of flash between 60-120 flashes per minute.
  - (4) A vehicle specified under this subchapter shall be equipped with one stop lamp. The stop lamp shall be red. See 75 Pa.C.S. §4303 (b).

- (5) The stop lamps shall be operated through a switching arrangement so that any motion of the brake towards the applied position immediately illuminates the stop lamp.
  - (6) The stop lamps shall not be combined with turn signal lamps unless arrangement of the switches or other parts are such that the stop lamp is extinguished when the turn signal is in use.
  - (7) The stop lamps shall be visible for 100 feet in normal sunlight.
  - (8) A motor-driven cycle registered shall be equipped with an alternator, generator or electrical energy storage source, capable of providing lighting in compliance with Chapter 153 and SAE J392-Appendix B (relating to motorcycle and motor vehicle cycle electrical system (maintenance of design voltage)—SAE J392) Maintenance of Design Voltage.
  - (9) A vehicle specified under this subchapter shall be equipped with at least one red reflector to the rear.
  - (10) A vehicle specified under this subchapter shall have at least one tail lamp if it was manufactured after 1973, or if originally so equipped.
- (g) Condition and Position of Lamps** - Lamps shall be properly fastened; direct light properly; be of color not contrary to Tables II, IV, and V; and may not be so obstructed by a screen, bar, auxiliary equipment or device as to obscure, change color of or obstruct beam.
- (h) Ornamental Lamps** - A lamp not enumerated in this section, and not located as described in Tables III-V of this chapter, is prohibited unless it is available as original equipment or is auxiliary lighting added to a motorcycle to protect the driver as permitted by 75 Pa.C.S. § 4310 (related to motorcycle lighting). An illuminated sign is prohibited. Flashing or revolving lights are not ornamental lamps. Provisions relating to flashing or revolving lights are located in Chapters 15 and 173 (relating to authorized vehicles and special operating privileges; and flashing or revolving lights on emergency and authorized vehicles).
- (i) [Reserved].**
- (j) Registration Plate Lamp** - A registration plate lamp, if originally equipped, shall emit white light and make the registration plate visible from a distance of 50 feet to rear.
- (k) Auxiliary Driving Lamps and Fog Lamps** - Auxiliary driving lamps and fog lamps may be installed on a motor-driven cycle or motorized pedalcycle if they comply with the following requirements:
- (1) Fog lamps shall not be substituted for headlamps except under conditions of rain or fog. Fog lamps may be used with lower headlamp beams.
  - (2) Auxiliary driving lamps and fog lamps shall be mounted on front at a height not less than 12 inches nor more than 42 inches above level surface upon which the vehicle stands. Rear fog lamps, if originally installed or offered as optional equipment, are acceptable.
  - (3) Auxiliary lamps and fog lamps shall be aimed when vehicle and lamp assembly are in the straight ahead position with beam not above horizontal centerline of lamp at 25 feet.
  - (4) A vehicle specified under this subchapter may have one and no more than two approved auxiliary driving lamps and fog lamps.
  - (5) Auxiliary driving lamps and fog lamps shall not be placed in front of any required lamp.
  - (6) A vehicle equipped with headlamps, auxiliary driving lamps, or fog lamps may not have more than four forward projecting lamps illuminated at the same time.
- (l) Antique Vehicle Lighting Exemption** - An antique vehicle, if operated exclusively between the hours of sunrise to sunset and not during periods of reduced visibility or insufficient illumination, are exempt from requirements of this section except requirements pertaining to stop lamps.
- (m) Battery Fastening** - A vehicle specified under this subchapter shall be equipped with a system for secure fastening of the battery.

**175.176. Glazing**

- (a) Condition of Glazing** - Glazing shall meet the requirements of Chapter 161 (relating to glazing materials). See 75 Pa.C.S. §4526 (relating to safety glass).



## Subchapter J - Motor-Driven Cycles and Motorized Pedalcycles

---

- (b) **Safety Glazing** - A vehicle specified under this subchapter may be equipped with a windscreen. Requirements of this subsection do not apply to a vehicle manufactured or assembled before January 1, 1934, if original glazing is not cracked or discolored.
- (c) **Stickers** - Out-of-state inspection stickers, tax stamps, road use permits or other government-related permits—all municipalities and states—may be placed at the lower left or right-hand corner of windscreen.
- (d) **Obstructions** - A vehicle specified under this subchapter shall have glazing free from obstructions as described in §175.190 (relating to inspection procedure).
  - (1) With the exception of materials in paragraph (3), signs, posters or other materials, whose design prevents a driver from seeing through the material, may not be placed on the windscreen or a side wing or a side window so as to obstruct, obscure or impair the driver's clear view of the highway or an intersecting highway. Under FMVSS No. 205, these restrictions do not apply to the rear side windows, rear wings or rear window of vehicles subject to this subchapter, if so equipped.
  - (2) The requirements of this subsection also apply to glass etchings, except those used for vehicle identification.
  - (3) A sun screening device or other material which does not permit a person to see or view the inside of the vehicle is prohibited unless otherwise permitted by FMVSS No. 205, or a certificate of exemption has been issued in compliance with §175.265 (relating to exemption provisions). See Table X for specific requirements for vehicles subject to this subchapter.

### 175.177. Mirrors

- (a) **Condition of Mirrors** - Mirrors shall be in safe operating condition as described in §175.190 (relating to inspection procedure).
- (b) **Rearview Mirrors** - A vehicle specified under this subchapter shall be equipped with at least one rearview mirror or similar device. If a certificate of exemption for a sun screening device or other material has been issued, rearview mirrors, each with a minimum reflective surface of 12 1/2 square inches for a flat mirror or 10 square inches for a convex mirror, shall be installed on both sides of a motor-driven cycle or motorized pedalcycle. A vehicle for which a certificate of exemption has been issued for medical reasons may be equipped with only a left outside rearview mirror, unless originally equipped with an outside rearview mirror on both sides of the vehicle.
  - (1) A mirror may not be cracked, broken or discolored.
  - (2) A mirror shall hold adjustment.
  - (3) A mirror shall provide an unobstructed view of highway to the rear of the vehicle for distance of not less than 200 feet.
  - (4) Mirrors shall provide a minimum reflective surface of 12 1/2 square inches for a flat mirror or 10 square inches for a convex mirror.
- (c) **Obstructions** - In vehicles specified under this subchapter rearview mirror shall be free from obstructions as described in §175.190.

### 175.178. Fuel Systems

- (a) **Condition of Fuel Systems** - All components in the fuel system shall be in safe operating condition as described in §175.190 (relating to inspection procedure).
- (b) **Fuel System Requirements** - The fuel system components shall be leakproof and shall be fastened securely to the vehicle with fasteners designed for that purpose.
- (c) **Accelerator Operation** - If the vehicle was originally equipped with an accelerator control system, the accelerator control system shall return the engine throttle to idle position when operator removes actuating force from accelerator control.
- (d) **Filler Cap** - The fuel system shall be equipped with filler cap.
- (e) **Alternate Fuel Systems** - See Subchapter M (relating to alternate fuel systems and controls).

**175.179. Speedometers**

Every motor-driven cycle shall have an operating speedometer calibrated to indicate miles per hour or kilometers per hour, if the vehicle was originally equipped with a speedometer.

**175.180. Odometers**

A vehicle specified under this subchapter shall have an operating odometer to indicate total miles or kilometers driven, if the vehicle was originally equipped with an odometer.

**175.181. Exhaust Systems**

- (a) **Condition of Exhaust System** - All components of the exhaust system shall be in safe operating condition as described in §175.190 (relating to inspection procedure).
- (b) **Exhaust System Requirements** - A vehicle specified under this subchapter shall be equipped with a muffler or other effective noise-suppressing system in good working order and in constant operation. A muffler or exhaust system may not be equipped with a cutout, bypass or similar device and a muffler may not show evidence of external repair.
  - (1) The exhaust system of a motor-driven cycle or motorized pedalcycle may not be modified in a manner which will amplify or increase noise emitted by the motor of vehicle above the maximum level permitted by Chapter 157 (relating to established sound levels).
  - (2) An exposed exhaust systems shall be equipped with an adequate heat shield or protective system or be located to prevent contact by the operator or passenger.

**175.182. Horns and Warning Devices**

- (a) **Condition of Horns and Warning Devices** - All components of a horn or warning device shall be in safe operating condition as described in §175.190 (relating to inspection procedure).
- (b) **Horn and Warning Device Requirements** - A vehicle specified under this subchapter shall have a horn or other warning device which is audible under normal conditions at a distance of not less than 200 feet. No vehicle shall be equipped with a siren, bell, whistle or similar device emitting any unreasonably loud or harsh sound, except emergency vehicles and vehicles equipped with an anti-theft device.

**175.183. Body**

- (a) **Condition of Body** - All items on the body shall be in safe operating condition as described in §175.190 (relating to inspection procedure).
- (b) **Fenders** - The wheels of a vehicle specified under this subchapter shall be equipped with fenders of a type used as original equipment. At no time shall tires come in contact with the body, fenders or chassis of the vehicle.
- (c) **Protruding Objects** - A vehicle specified under this subchapter shall have no torn metal, glass or other loose or dislocated parts protruding from body.

**175.184. Chassis**

- (a) **Condition of Chassis** - All items on the chassis shall be in safe operating condition as described in §175.190 (relating to inspection procedure).
- (b) **Vehicle Frame** - A vehicle frame shall be in solid condition.
- (c) **Seats** - A vehicle specified under this subchapter shall be equipped with seat for operator which is firmly anchored to frame or support. No metal spring shall protrude from the driver's seat.
- (d) **Chain Guard or Drive Shaft Cover** - A covering device, to prevent contact with a rider while in the normal riding position, shall be provided.
- (e) **Stands** - A vehicle specified under this subchapter shall have stands which are required to operate and be strong enough to support the vehicle and stay in proper position when not holding the vehicle in standing position.

## Subchapter J - Motor-Driven Cycles and Motorized Pedalcycles

---

- (f) **Hand-Hold** - A hand-hold device shall be provided if motor-driven cycle or motorized pedalcycle is designed to carry more than one person.
- (g) **Footrests** - A vehicle specified under this subchapter operated upon highway shall have footrests or pedals for each person operating and footrests for each person riding upon vehicle.
- (h) **Highway Bars** - If the vehicle specified under this subchapter is so equipped, highway bars shall have a maximum width of 26 inches, and shall be located not more than 15 inches from the foot controls and may not interfere with the operation of the foot controls.

### 175.190. Inspection Procedure

- (a) **External Inspection** - An external inspection of motor-driven cycles only shall be performed as follows:
  - (1) Verify ownership, legality, and proof of financial responsibility. For the purpose of this subchapter, ownership and legality shall be proven by a vehicle registration card, certificate of title or manufacturer's statement of origin. When a vehicle is being held for resale is presented for inspection by a dealer licensed to sell vehicles in this Commonwealth, a VIN-specific auction slip or VIN-specific secure power of attorney evidencing the dealership's acquisition of the vehicle, or both, may be presented instead of a vehicle registration card, certificate of title, manufacturer's statement of origin. **REJECT IF** one or more of the following apply:
    - (i) When vehicle ownership and legality are demonstrated by presentation of certificate of title, manufacturer's statement of origin, VIN-specific auction slip or VIN-specific secure power of attorney:
      - (A) The VIN is not in agreement with the certificate of title, manufacturer's statement of origin, VIN-specific auction slip or VIN-specific secure power of attorney. Exception: If only one digit is incorrect or two digits are transposed, and the owner provides evidence that the appropriate Department form has been completed to correct the error or transposition.
      - (B) The VIN plate is not securely fastened or is defaced, misplaced or missing.
    - (ii) When vehicle ownership and legality are demonstrated by presentation of vehicle registration card:
      - (A) The license plate is not in agreement with the numbers on the vehicle registration card. Exception: If only one digit is incorrect or two digits are transposed, and the owner provides evidence that the appropriate Department form has been completed to correct an error or transposition.
      - (B) The license plate is hanging loosely from its mounting bracket.
      - (C) The license plate is obscured so that numbers cannot be identified.
      - (D) The license plate lamp, if so equipped, does not illuminate the license plate.
    - (iii) Acceptable proof of financial responsibility is not provided. For the purpose of this chapter, financial responsibility shall be proven by one of the following documents:
      - (A) A valid financial responsibility identification card issued in accordance with 31 Pa. Code (relating to insurance).
      - (B) The declaration page of a valid insurance policy.
      - (C) A valid self-insurance identification card.
      - (D) A valid binder of insurance issued by an insurance company licensed to sell motor vehicle liability insurance in this Commonwealth.
      - (E) A valid insurance policy issued by an insurance company licensed to sell motor vehicle liability insurance in this Commonwealth.
  - (2) Check the Glazing.
    - (i) **REJECT IF** any of the following apply:
      - (A) Approved safety glazing is not used in windscreen.
      - (B) A sign, poster or other material whose design prevents a driver from seeing through the

material, obstructs, obscures or impairs the driver's clear view of the highway or an intersecting highway. Under FMVSS No. 205, this restriction does not apply to the rear side windows, rear wings or rear window of vehicles subject to this subchapter, if so equipped.

- (C) A vehicle displays a sticker other than those prescribed under §175.176(c) (relating to glazing), or displays a parking sticker in a location described in §175.176(d).
  - (D) Glass is shattered or broken or has any exposed sharp edges.
  - (E) There are defects in an acute area of windshield—center of the critical area on the driver's side of the vehicle directly in the driver's normal line of vision 8 1/2 inches wide and 5 1/2 inches high—or discolorations or hazardous cracks which would interfere with the driver's vision.
- (ii) This paragraph does not prohibit the use of a product or material along the top edge of the windshield as long as the product or material is transparent and does not encroach upon the AS-1 portion of the windshield as provided by FMVSS No. 205 and the product or material is not more than 3 inches from the top of the windshield.
- (3) Check the mirrors and **REJECT IF** one or more of the following apply:
- (i) The mirror is cracked, broken or discolored.
  - (ii) The mirror will not hold adjustment.
  - (iii) The mirror does not provide a minimum reflective surface of 12 1/2 square inches for a flat mirror or 10 square inches for a convex mirror.
  - (iv) Outside rearview mirrors, with a minimum reflective surface as described in §175.177(b) (relating to mirrors), are not installed on both sides of the vehicle, if a certificate of exemption for a sun screening device or other material has been issued by the Department. See §175.264 (relating to mirrors). A vehicle for which a certificate of exemption has been issued for medical reasons may be equipped with only a left outside rearview mirror, unless originally equipped with an outside rearview mirror on both sides of the vehicle.
- (4) Check fenders and **REJECT IF** any of the following apply:
- (i) A fender—front or rear—has been removed.
  - (ii) A fender is not of a type and size used as original equipment.
- (5) Check the lamps and lenses and **REJECT IF** one or more of the following apply:
- (i) An exterior bulb or sealed beam, if originally equipped or installed, fails to light properly, except ornamental lights.
  - (ii) The turn signal lamps do not flash between 60-120 flashes per minute.
  - (iii) The turn signal lamps do not properly indicate the right or left, when so switched.
  - (iv) The lamp shows a color contrary to Tables IV or V (relating to required motor vehicle lighting equipment; and location of required equipment), as applicable.
  - (v) The lamp or filament indicated at switch position does not light when the correct switch indicates the lamp should be on.
  - (vi) The lamp has a missing or broken lens.
  - (vii) A required lamp is missing.
  - (viii) Auxiliary equipment is placed on, in or in front of any lamp.
  - (ix) The fog lamps operate with high beams of headlamps.
  - (x) Auxiliary driving lamps operate with the low beam of standard headlamp system or alone.
  - (xi) The headlamps are out of adjustment as follows:
    - (A) Mechanical aimer:
      - (I) The horizontal aim is more than 4 inches to the left or right.
      - (II) The vertical aim is higher or lower than 4 inches from center.

(B) Screen or photo electric type tester. See charts 1-3 (relating to headlight aiming screen distance and marking identification; high beam inspection limits; and low beam inspection limits):

- (I) Turn the lamps on high beam and **REJECT IF** the center of the beam is horizontally more than 4 inches to right or left of straight ahead or if the center of the light beam is vertically more than 4 inches above or below horizontal line.
- (II) Turn the lamps on low beam and **REJECT IF** upper edge of beam is more than 4 inches above or below horizontal center line of headlamp or if inner edge of beam is more than 4 inches to right or left of vertical line.

- (6) Check for protruding metal and **REJECT IF** torn metal, glass, or other loose or dislocated parts protrude from surface of vehicle so as to create a hazard.
- (7) Check the fuel tank cap and **REJECT IF** the fuel tank filler cap is missing.
- (8) Check the battery and **REJECT IF** the battery is not securely fastened.

**(b) Internal Inspection** - An internal inspection of motor-driven cycles only shall be performed as follows:

- (1) Check the high beam and turn signal indicator lamps and **REJECT IF** the indicator lamps are not working.
- (2) Check the horn and **REJECT IF** any of the following apply:
  - (i) There is no horn or other acceptable audible warning device.
  - (ii) The horn or other warning device is not audible under normal conditions for a distance of not less than 200 feet.
  - (iii) A vehicle is equipped with a siren, bell, whistle or a device emitting harsh or unreasonably loud sound except emergency vehicles and vehicles equipped with an anti-theft device.
- (3) Check the brake system and **REJECT IF** any of the following apply:
  - (i) There is excessive friction in the control linkage or components, or if the control levers are misaligned or improperly positioned.
  - (ii) There is mechanical damage other than wear.
- (4) Check the motor mounts and **REJECT IF** motor mounts are broken.
- (5) Check the fuel systems and controls and **REJECT IF** any of the following apply:
  - (i) There is liquid fuel leakage at any point in system.
  - (ii) Part of the fuel line is not securely fastened.
  - (iii) The fuel tank or line was not specifically designed or manufactured as fuel tank or line.
  - (iv) The fuel line is in contact with high temperature surfaces or moving parts.
  - (v) The fuel tank or line intrudes into a driver, passenger or cargo compartment, except if the vehicle was originally so designed. If the vehicle is equipped with an alternate fuel system, see Subchapter M (relating to alternate fuel systems and controls).
  - (vi) The throttle, if originally equipped, does not return to the idle position when actuating force is removed.

**(c) Beneath the Vehicle Inspection** - A beneath the vehicle inspection of motor-driven cycles only shall be performed as follows:

- (1) Inspect the tires and wheels and **REJECT IF** one or more of the following apply:
  - (i) A tire has two adjacent treads with less than 1/32 inch tread remaining.
  - (ii) Part of the ply or cord is exposed.
  - (iii) A tire has been repaired with blow-out patch.
  - (iv) There is a bump, bulge or separation.

- (v) A tire is marked "not for highway use," "for racing purposes only" or "unsafe for highway use," or has a similar designation.
  - (vi) There are other conditions or markings reasonably believed to render tire unsafe for highway use.
  - (vii) A tire has been regrooved or recut.
  - (viii) The wheel nuts or bolts are missing or loose or have improper thread engagement.
  - (ix) The stud or bolt holes are worn out of round.
  - (x) Part of the wheel is bent, cracked, welded or damaged so as to affect safe operation of vehicle.
  - (xi) The rear wheel does not track front wheel track in straight ahead position within one inch to either side.
  - (xii) Studded tires are in use after April 15 and before November 1.
  - (xiii) A tire extends beyond body line, a tire is smaller than the manufacturer's recommended minimum size, or below the manufacturer's recommended load rating or a tire makes contact with the body or chassis.
- (2) Inspect the steering system and **REJECT IF** one or more of the following apply:
- (i) The handlebars, grips or steering system are not of sturdy construction.
  - (ii) The handlebars or steering system restrict the front fork movement.
  - (iii) The handlebars do not provide a minimum of 18 inches between the grip ends. If equipped with a steering wheel instead of handlebars, the steering wheel, except if specially designed for handicapped drivers, is not circular or equivalent in strength to original equipment or has an outside diameter less than 13 inches.
  - (iv) The handlebars are not equipped with grips of non-slip design and material.
  - (v) Measured movement at the front or rear of the tire is greater than 1/4 inch in relation to the axle shaft.
  - (vi) The linkage components are not secured with cotter pins or other suitable devices.
  - (vii) The steering stops allow a tire to rub on the frame or chassis parts.
  - (viii) The front wheel is incapable of being turned to the right and left steering stops without binding or interference.
- (3) Inspect the vehicle frame and **REJECT IF** any of the following apply:
- (i) The vehicle frame is not in solid condition.
  - (ii) A repair is made with tape, tar paper or cloth, or is made in another temporary manner.
  - (iii) The frame components are missing cracked, rotted or broken or are in a deteriorated or dangerous condition.
  - (iv) The chain guard or other covering device is missing.
  - (v) The stand does not operate or is not strong enough to support vehicle.
  - (vi) The hand-hold device is not provided if motorcycle is designed to carry more than one person.
  - (vii) The footrests or pedals are not provided for each person operating or footrests are not provided for each person riding upon vehicle.
  - (viii) The highway bars exceed maximum width of 26 inches or are located more than 15 inches from foot controls.
- (4) Inspect the exhaust system and **REJECT IF** one or more of the following apply:
- (i) The vehicle has no muffler or muffler has external repair.
  - (ii) There are loose or leaking joints.

- (iii) There are holes, cracks or leaking seams in the exhaust system.
  - (iv) There is a muffler cutout or similar device.
  - (v) The elements are not securely fastened with proper clamps and hangers.
  - (vi) The exposed exhaust system does not have an adequate heat shield or protective system or is not located to prevent contact with riders.
- (d) Road Test** - Perform a road test and **REJECT IF** any of the following apply:
- (1) The vehicle is not capable of stopping within the maximum stopping distance prescribed in Table I.
  - (2) There is a malfunction of the braking or steering mechanism - particularly shimmy, wander or pull-or another questionable operating behavior that affects safe operation of vehicle.
  - (3) The speedometer, if originally equipped, does not operate.
  - (4) The odometer, if originally equipped, does not operate, except motor-driven cycles at least 25 years old.
  - (5) The vehicle cannot be driven forward.
- (e) Exemption** - A motorized pedalcycle is exempt from inspection.

## Subchapter K

# STREET RODS, SPECIALLY CONSTRUCTED AND RECONSTRUCTED VEHICLES

### 175.201. Application of Subchapter

The equipment standards set forth in this subchapter shall apply to all street rods, specially constructed vehicles and reconstructed vehicles being driven on highways.

### 175.202. Conditions

All parts of a vehicle must comply with this Subchapter and Subchapters E-H and J.

### 175.203. Braking Systems

- (a) **Condition of Braking Systems** - Braking systems and components shall be compatible and in safe operating condition as described in §175.80, 175.110, 175.130, 175.160, 175.190, and 175.220.
- (b) **Service Brakes** - The service brakes shall act on all wheels upon application and shall be capable of stopping the vehicle in not more than the maximum stopping distance prescribed in Table I (relating to brake performance). Every street rod, specially constructed vehicle and reconstructed vehicle shall be equipped with a service brake system which is identical to the originally manufactured brake system; except, if the original system has been modified or the street rod has rear tires wider than 9 inches, the service brake system shall be of a design that rupture or failure of either the front or rear brake system will not result in the complete loss of braking function. Braking function may be obtained by hydraulic or other means through a normal brake mechanism. In the event of a rupture or failure of actuating force component, unaffected brakes shall be capable of applying adequate braking force to the vehicle.
- (c) **Refuse Trucks** - A vehicle reconstructed as a refuse trucks and designed to be operated from an unconventional location—usually the right side of the vehicle—shall be equipped with a system that prevents movement of the vehicle when the operator is not at the controls. This system shall engage the brakes and lock the transmission in neutral. This system need be operative only when the vehicle is being operated from the unconventional location.

### 175.204. Tires

- (a) **Condition of Tires** - Tires shall be in safe operating condition as described in this Subchapter and Subchapters E-H and J.
- (b) **Tire Width** - The front tires on a street rod shall have a minimum width of 5 inches. If the rear tires on a street rod are wider than 9 inches, the vehicle shall be equipped with a dual service brake system, see S175.203(b) (relating to braking systems).

### 175.205. Lighting and Electrical Systems

A vehicle specified under this subchapter shall have hazard warning lamps if so originally equipped which, under normal atmospheric conditions, shall be capable of being seen and distinguished during nighttime operation at a distance of 500 feet. See 75 Pa.C.S. §4303(b), (c) and (d) (relating to general lighting requirements).

### 175.206. Glazing

- (a) **Condition of Windshield** - A windshield shall be in safe operating condition as described in §175.80, 175.110, 175.130, 175.160, 175.190, and 175.220 and this subchapter.
- (b) **Requirements** - Glazing shall meet following requirements:
  - (1) A windshield may not be less than 7 inches in vertical height on a street rod and 12 inches vertical height on reconstructed vehicles and specially constructed vehicles. If the original body configuration provided by a recognized manufacturer had a windshield of less than 12 inches, reconstructed vehicles and specially constructed vehicles may use the original windshield size, except that this size may not be less than 7 inches.



## Subchapter K - Street Rods, Specially Constructed and Reconstructed Vehicles

---

- (2) A windshield and side windows or openings shall allow the driver minimum outward horizontal vision capability of 90 degrees from each side of the vertical plane passing through the fore and aft centerline of the vehicle. This range of vision may be interrupted by window framing not exceeding 2 inches in width and windshield door post support areas not exceeding 4 inches in width.
- (c) **Obstructions Forward of the Windshield** - A vehicle specified under this subchapter may not have obstruction forward of the windshield which extends more than 2 inches upward into the horizontally projected vision area of the windshield with the exception of the windshield wiper components.

### 175.207. Mirrors

- (a) **Condition of Mirrors** - Mirrors shall be in safe operating condition as described in §175.80, 175.110, 175.130, 175.160, 175.190, and 175.220 and this subchapter.
- (b) **Mirrors** - A specially constructed or reconstructed vehicle designed to be operated from an unconventional location—usually the right side—shall have sufficient mirrors for the operator to view the front and both sides and rear of the vehicle for a distance not less than 200 feet from any operator location.

### 175.208. Body

- (a) **Condition of Body** - All items on the body shall be in safe operating condition as described in §175.80, 175.110, 175.130, 175.160, 175.190, and 175.220 (relating to inspection procedure) and this subchapter.
- (b) **Fenders** - A vehicle specified under this subchapter shall have fenders on all wheels which cover the entire tread width of a tire that comes in contact with the road surface. The tire tread circumference coverage shall be from at least 15 degrees front to at least 75 degrees rear of the vertical centerline at each wheel, measured from the center of wheel rotation. Vehicles registered as street rods are exempt from the requirements regarding fenders.
- (c) **Hood-Street Rods Only** - A street rod is not required to have a hood which covers the top of the entire engine compartment. If the hood top or sides, or both, are removed from the vehicle, the engine fan must be enclosed with a shroud designed to protect the fan from accidental contact from the outside.
- (d) **Doors** - A door shall be installed for any location from which a refuse truck is to be operated. If the vehicle is equipped with dual controls, a door shall be installed at each control position.

### 175.209. Chassis

- (a) **Condition of Chassis** - All items of a chassis shall be in safe operating condition as described in this subchapter and Subchapters E-H and J.
- (b) **Bumpers** - A vehicle specified under this subchapter shall be equipped with front and rear bumpers securely attached to the chassis, except when the original body configuration provided by a recognized manufacturer did not include bumpers in the design of the vehicle. Vehicles registered as street rods are exempt from the requirements regarding bumpers.
- (1) Some part of the main horizontal bumper of a passenger vehicle and all street rods, if so equipped, shall fall within 12-20 inches above ground level.
- (2) Some part of the horizontal bumper of a truck shall fall within 16-30 inches above ground level.
- (c) **Scrub Line** - A vehicle specified under this subchapter shall meet the minimum scrub line requirements. See Chart 5 (relating to scrub line).
- (1) A scrub line is an imaginary surface created if lines were drawn from the bottom of the wheel rim on one side to the bottom of the tire on the other side. When lines are drawn from both sides, an “X” under the vehicle suspension is created. A suspension or chassis component may not be below the top portion of this imaginary “X.”
- (2) Only exhaust system and sheet metal may extend below the scrub line.

### 175.210. Unconventional Operator Location

A vehicle described under this subchapter designed to be operated from an unconventional location shall have all

controls and switches listed as follows positioned so they may be conveniently operated from each operator location.

1. A steering wheel.
2. A gear shift.
3. Brake controls.
4. Windshield wiper controls.
5. A speedometer.
6. A headlamp and tail lamp control.
7. A turn signal control.
8. A defroster control.
9. A hazard warning light control.
10. A horn or warning device activator.

### **175.211. Inspection**

A vehicle shall be inspected by a certified inspection mechanic to insure the vehicle conforms to Vehicle Code and this title prior to titling. The vehicle owner shall not be the inspecting mechanic. A certificate of inspection shall not be issued upon initial inspection. After the title and registration have been issued, an inspection station shall reinspect the vehicle to make certain the vehicle still complies with this chapter and only then shall a certificate of inspection be issued. Failure to follow proper inspection procedures in either of the two inspections listed in this chapter will be reasonable grounds to suspend the station and mechanic under Subchapter D (relating to schedule of penalties and suspensions: official inspection stations and certified mechanics).

### **175.220. Inspection Procedure**

(a) **External Inspection** - An external inspection shall be performed as follows:

- (1) Verify ownership, legality, and proof of financial responsibility. For the purpose of this subchapter, ownership and legality shall be proven by a vehicle registration card, certificate of title or manufacturer's statement of origin. When a vehicle being held for resale is presented for inspection by a dealer licensed to sell vehicles in this Commonwealth, a VIN-specific auction slip or VIN-specific secure power of attorney evidencing the dealership's acquisition of the vehicle, or both, may be presented instead of a vehicle registration card, certificate of title or manufacturer's statement of origin. **REJECT IF** one or more of the following apply:
  - (i) When vehicle ownership and legality are demonstrated by presentation of certificate of title, manufacturer's statement or origin. VIN-specific auction slip or VIN-specific secure power of attorney:
    - (A) The VIN is not in agreement with the certificate of title, manufacturer's statement of origin. VIN-specific auction slip or VIN-specific secure power of attorney. Exception: If only one digit is incorrect or two digits are transposed, and the owner provides evidence that the appropriate Department form has been completed to correct the error or transposition.
    - (B) The VIN plate is not securely fastened or is defaced, misplaced or missing.
  - (ii) When vehicle ownership and legality are demonstrated by presentation of vehicle registration card:
    - (A) The license plate is not in agreement with numbers on vehicle registration card. If only one digit is incorrect or two digits are transposed, and the owner provides evidence that the appropriate Department form has been completed to correct an error or transposition, this clause does not apply.
    - (B) The license plate is hanging loosely from its mounting bracket.
    - (C) The license plate is obscured so that the numbers cannot be identified.
    - (D) The license plate lamp, if so equipped, does not illuminate the license plate.
  - (iii) Acceptable proof of financial responsibility is not provided. For the purpose of this chapter, financial

responsibility shall be proven by one of the following documents:

- (A) A valid financial responsibility identification card issued in accordance with 31 PA Code (relating to insurance).
- (B) The declaration page of a valid insurance policy.
- (C) A valid self-insurance identification card.
- (D) A valid binder of insurance issued by an insurance company licensed to sell motor vehicle liability insurance in this Commonwealth.
- (E) A valid insurance policy issued by an insurance company licensed to sell motor vehicle liability insurance in this Commonwealth.

(2) Check the windshield and **REJECT IF** one or more of the following apply:

- (i) A windshield is less than 7 inches in vertical height on a street rod.
- (ii) A windshield is less than 12 inches in vertical height, or the vertical height is less than what was originally designed, on a reconstructed or specially constructed vehicle.
- (iii) The windshield and side windows or openings do not allow the driver minimum outward horizontal vision capability of 90° from each side of vertical plane passing through before and after centerline of vehicle.
- (iv) The range of vision is interrupted by window framing exceeding 2 inches in width and windshield door post support areas exceeding 4 inches in width.
- (v) Obstructions except windshield wiper components of more than 2 inches upward into horizontally projected vision area of the windshield is found.

(3) With the exception of vehicles registered as street rods, check the fenders and **REJECT IF** one or more of the following apply:

- (i) The fenders do not cover the entire tire tread width of tire that comes in contact with the road surface.
- (ii) The front tire tread circumference coverage is less than 15° to the front and 75° to the rear of each tire.
- (iii) The rear tire tread circumference coverage is less than 75°.

(4) With the exception of vehicles registered as street rods, check the bumpers and **REJECT IF** one or more of the following apply:

- (i) The front or rear bumper is missing.
- (ii) Some part of the main horizontal bumper does not fall within 12-20 inches above the ground level on specially constructed vehicles and reconstructed passenger vehicles.

(5) Check the lights and **REJECT IF** the vehicle does not have operating hazard warning lamps capable of being seen and distinguished during nighttime operations at a distance of 500 feet.

**(b) Internal Inspection** - An internal inspection shall be performed as follows:

- (1) Check the mirrors and **REJECT IF** the mirrors for the operator are insufficient to view front and both sides and rear of vehicle for distance not less than 200 feet.
- (2) Check the unconventional operation location and **REJECT IF** all the major controls and switches are not conveniently located for use by the driver while in an unconventional operating position

**(c) Under the hood Inspection** - An under the hood inspection shall be performed as follows:

- (1) Check the engine compartment and reject if the street rod hood top and sides, or both, are removed from the vehicle and the engine fan is not enclosed with a shroud designed to protect the fan from accidental contact from the outside.
- (2) Check the brake system and **REJECT IF** any of the following apply:
  - (i) The dual service brake system is not installed when the original system was modified.

- (ii) The dual service brake system is not installed on the vehicle with the rear tires exceeding 9 inches in width.

**(d) Beneath the Vehicle Inspection** - A beneath the vehicle inspection shall be performed as follows:

- (1) Inspect the tires and **REJECT IF** any of the following apply:
  - (i) The front tires measure less than 5 inches in width on the street rods.
  - (ii) The rear tires exceed 9 inches in width and the vehicle is not equipped with dual service brake system.
- (2) Inspect the scrub line and **REJECT IF** any of the following chassis and suspension components are below the scrub line:
  - (i) The Frame
  - (ii) The Axle
  - (iii) The Axle Housing
  - (iv) The Lower Control Bar
  - (v) The Shock Mounts
  - (vi) The Crossmembers
  - (vii) The Torsion bar
  - (viii) The Radius Rods
  - (ix) The Spindle Arms
  - (x) The Steering Components
  - (xi) The Brake Components
  - (xii) The Spring Perch Bolts

## Subchapter L

# ANIMAL-DRAWN VEHICLES, IMPLEMENTS OF HUSBANDRY AND SPECIAL MOBILE EQUIPMENT

### 175.221. Application of Subchapter

Equipment standards set forth in this subchapter shall apply to all animal-drawn vehicles, implements of husbandry and special mobile equipment driven on highways.

### 175.222. Steering

- (a) **Condition of Steering Components** - The steering assembly and steering mechanism shall be in safe operating condition as prescribed in this subchapter.
- (b) **Steering Wheel** - The steering wheel, if so equipped, must be equivalent to the original equipment in material, strength and size. A modification affecting the steering of vehicle must be corrected.
- (c) **Frame** - The frame may not be bent in such a manner as to affect the steering.

### 175.223. Braking Systems

- (a) **Condition of Braking Systems** - Braking systems and components shall be in safe operating condition as described in this subchapter.
- (b) **Service Brakes** - A vehicle specified under this subchapter shall be equipped with service brake system. This section shall not apply to nonself-propelled special mobile equipment having a gross weight which does not exceed 40% of the gross weight of the towing vehicle, or to a towed implement of husbandry.
  - (1) The service brake system shall be adequate to control movement and stop and hold the vehicle or combination on any grade on which it is operated under all conditions of loading.
  - (2) A service brake system shall act upon wheels according to the original manufacturer's specifications.
  - (3) The brake lining and fluids utilized in the braking function shall be of a type approved by the vehicle manufacturer.
- (c) **Parking Brake System** - A vehicle shall be equipped with a parking brake system except a towed implement of husbandry and towed special mobile equipment. See 75 Pa.C.S. §4502 (relating to general requirements for braking systems). A parking brake system shall be adequate to hold the vehicle on a surface free from ice or snow on 20% grade.
- (d) **Breakaway System** - A trailer operated on the highway, except a towed implement of husbandry, which is equipped with brakes or has a gross weight in excess of 3,000 pounds shall be equipped with a breakaway system which shall stop and hold the vehicle automatically upon breakaway from the towing vehicle.

### 175.224. Tires and Wheels

- (a) **Condition of Tires and Wheels** - Tires and wheels or traction surfaces shall be in safe operating condition as described in this subchapter.
- (b) **Tire Standards**
  - (1) If of pneumatic type, the tires shall be operated at a cold inflation pressure no less than that specified for the load being carried.
  - (2) The tires shall meet the minimum manufacturer specifications as to tire size and shall be free of defective conditions reasonably believed to render the tire unsafe for highway use.
  - (3) The wheel nuts, bolts, clamps or lugs shall have proper thread engagement; and wheels shall not be bent, cracked or damaged in such a way as to affect safe operation of vehicle.
- (c) **Nonpneumatic Tires** - A vehicle equipped with nonpneumatic tires shall meet the following requirements:
  - (1) An implement of husbandry or special mobile equipment shall not be equipped with cleats or guide bands

which come in contact with the highway of a greater height or less width than that specified for classes and gross weights as follows- except caterpillar or crawler type vehicles:

Gross Weight in Pounds	Cleats		Guide Bands	
	Max. Height	Min. Width	Max. Height	Min. Width
Less than 12,000	2"	3/8"	1 1/2"	2"
12,000 and over	2"	1"	1 1/2"	2"

- (2) When cleats are placed diagonally across the face of the driving surface or placed in two sections similar to the letter "V," cleats shall be spaced so as not to exceed 9 inches from center to center, measured at right angles to the cleats. When the cleats are placed on the driving surface in two sections—standard type of cleat mounting—sections shall be spaced so as not to exceed 7 1/2 inches from the center measured at right angles to the cleats. The cleats and guide bands shall have a flat surface with rounded edges.
- (3) An implement of husbandry or special mobile equipment shall not be equipped with caterpillar or crawler type cleats or grousers or guide bands—which come in contact with highway of greater height or less width than specified for classes and gross weights as follows:

Gross Weight in Pounds	Cleats		Guide Bands	
	Max. Height	Min. Width	Max. Height	Min. Width
Less than 7,500	2"	1"	1 1/2"	2"
7,500 and over but less than 12,000	2"	1 1/2"	1 1/2"	2"
12,000 and over	2"	2"	1 1/2"	2"

- (4) The cleats or grousers on a caterpillar or crawler type tractors shall have a flat surface with rounded edges; shall be placed at right angles to front to rear axis of the vehicle, so arranged that five or more cleats on each traction surface shall be in road contact with highway; and shall not be less than 3/4 of the width of the tread or driving surface.
- (5) An animal-drawn vehicle is permitted non-pneumatic tires.
- (d) **Alignment** - Tires or wheels may not be out of alignment to such a degree that steering control is affected.
- (e) **Tires and Rims** - The axles of a vehicle specified under this subchapter shall be equipped with tires and rims as originally designed.

**175.225. Lighting and Electrical Systems**

- (a) **Condition of Lamps and Switches** - Every required lamp or switch shall be in safe operating condition as described in this subchapter.
- (b) **Lighting Standards** - An external lighting system shall meet the requirements of this subchapter.
- (c) **Headlamp System** - An animal-drawn vehicle, implement of husbandry, or special mobile equipment operated on the highway between sunset and sunrise or during periods of reduced visibility or insufficient illumination shall be equipped with the following lamps:
  - (1) A self-propelled implement of husbandry and special mobile equipment shall be equipped with at least a two-headlamp system.
  - (2) At least one lamp shall be located on each side of the vehicle centerline.
  - (3) At a distance of 75 feet, the high intensity portion of the beam shall not be higher than 42 inches above level ground upon which vehicle stands.
  - (4) A vehicle with a headlamp system shall have a manual dimmer switch, as originally equipped, conveniently located for use by the driver while in a normal operating position. An automatic dimming

devices may be used in addition to a manual switch.

- (5) A vehicle with a headlamp system shall have a beam indicator, as originally equipped, which shall be lighted whenever the high beam of light from the headlamp is in use and shall not otherwise be lighted. The indicator shall be located so that when lighted it is readily visible without glare to the operator of vehicle.
- (6) A vehicle shall not have auxiliary equipment so placed as to obstruct beam.
- (e) **Other Required Lamps** - A vehicle specified under this subchapter operated on the highway between sunset and sunrise or during periods of reduced visibility, or insufficient illumination shall be equipped with all of the following:
  - (1) One red reflex reflector or reflective tape with a minimum of 3 square inches of surface on rear of each side of vehicle.
  - (2) One amber reflex reflector or reflective tape with a minimum of 3 square inches of surface on front of each side of vehicle.
  - (3) One double-faced—amber to front, red to rear—hazard lamp on each side of the vehicle or two amber hazard warning lamps on front and two red hazard warning lamps on the rear of vehicle.
- (f) **Illumination** - Lamps shall direct light properly and not be of a color contrary to law.
- (g) **Battery Fastening** - A vehicle specified under this subchapter shall be equipped with a system for secure fastening of the battery, if applicable.

#### **175.226. Glazing**

- (a) **Condition of Glazing** - Glazing shall meet requirements of Chapter 161 (relating to glazing materials). See 75 Pa.C.S. §4526 (relating to safety glass).
- (b) **Stickers** - Out-of-state inspection stickers, tax stamps, road use permits or other government-related permits—all municipalities and states shall be placed at the lower left or right-hand corner of the windshield.
- (c) **Obstructions** - Vehicle glazing shall be free from obstructions as described in this subchapter. No sign, poster or other material may be placed on the windshield or front side windows so as to obstruct, obscure or impair the driver's clear view of the highway or an intersecting highway.
- (d) **Sun Screening Devices** - A sun screening device or other material which does not permit a person to see or view the inside of the vehicle is prohibited unless a certificate of exemption has been issued in compliance with §175.265 (relating to exemption provisions). This subsection applies only to motor vehicles. See Table X for specific requirements for vehicles subject to this subchapter.

#### **175.227. Mirrors**

- (a) **Condition of Mirrors** - Mirrors shall be in safe operating condition as described in this subchapter.
- (b) **Rearview Mirrors** - A vehicle—except a trailer, implement of husbandry and special mobile equipment not originally so equipped—when operated on highway shall be equipped with at least one rearview mirror or similar device which provides the driver an unobstructed view of the highway to the rear of the vehicle for a distance of not less than 200 feet. A mirror shall not be broken, cracked, or discolored.

#### **175.228. Fuel Systems**

- (a) **Condition of Fuel Systems** - All components in a fuel system shall be in safe operating condition as described in this subchapter.
- (b) **Fuel System Requirements** - The fuel system components shall be leakproof and shall be fastened securely to the vehicle with fasteners designed for that purpose.
- (c) **Accelerator Operation** - The accelerator control system shall return the engine throttle to idle position when operator removes actuating force from accelerator control or shall be as originally equipped.
- (d) **Alternate Fuel Systems** - See Subchapter M (relating to alternate fuel systems and controls).

**175.229. Exhaust Systems**

- (a) **Condition of Exhaust System** - All components of an exhaust system shall be in safe operating condition as described in this subchapter.
- (b) **Exhaust System Requirements** - A vehicle shall be constructed, equipped, maintained and operated so as to prevent the engine exhaust gases from penetrating and collecting in any part of the vehicle occupied by the driver or passenger.
- (c) **Mufflers** - A vehicle specified under this subchapter shall be equipped with a muffler or other noise-suppressing system in good working order and in constant operation, if applicable. No muffler or exhaust system shall be equipped with a cutout, bypass or similar device, and no muffler shall show evidence of external repair.

**175.230. Horns and Warning Devices**

- (a) **Condition of Horns and Warning Devices** -All components of a horn or warning device shall be in safe operating condition as described in this subchapter.
- (b) **Horn and Warning Device Requirements** -A vehicle, except a trailer, implement of husbandry and special mobile equipment not originally equipped shall have a horn or other warning device which is audible under normal conditions at distance of not less than 200 feet.



## Subchapter M

### ALTERNATE FUEL SYSTEMS AND CONTROLS

#### 175.241. Compressed and Liquefied Gas Fuel Systems

- (a) **Reference Publications** - Regulatory, statutory, and informational publications may be obtained at the addresses indicated:
- (1) ASME Code - The American Society of Mechanical Engineers codes for boilers and pressure vessels may be obtained from:  
United Engineering Center  
345 East 47th Street  
New York, New York 10017
  - (2) ASTM Standards - The American Society for Testing and Materials Standards may be purchased from:  
American Society for Testing and Materials  
1916 Race Street  
Philadelphia, Pennsylvania 19103
  - (3) Bureau of Explosives - Information on approval of safety devices by the Bureau of Explosives may be obtained from:  
Bureau of Explosives  
Association of American Railroads  
1920 L Street N.W.  
Washington, D.C. 20036
  - (4) CGA Pamphlet - The Compressed Gas Association pamphlet may be obtained from:  
Compressed Gas Association, Inc.  
500 Fifth Avenue  
New York, New York 10036
  - (5) Code of Federal Regulations - The Code of Federal Regulations, Title 49, "Transportation," Parts 100 to 199, may be purchased from:  
Superintendent of Documents  
United States Government  
Printing Office  
Washington, D.C. 20402
  - (6) National Fire Protection Association Pamphlet-58. This pamphlet may be obtained from:  
NFPA  
470 Atlantic Avenue  
Boston, Massachusetts 02210
- (b) **Liquefied Petroleum Gas** - A fuel system using liquefied petroleum gas (LPG) shall meet the following requirements in addition to those in subsection (e).
- (1) **Fuel Supply Contained.** An LPG fuel supply container shall be constructed, inspected, and permanently marked in accordance with the appropriate DOT regulation or ASMF code. A container constructed to the DOT regulations shall have a minimum service pressure of 240 psi. Containers constructed to the ASME shall have a minimum working pressure of 250 psi. That containers installed in enclosed space, including automobile trunks or cabinets on vehicles and all engine fuel containers shall be constructed for at least a 312.5 psig design pressure. A container shall be equipped with a fixed liquid level gauge to indicate when the container is 79.8% full. A float gauge does not meet the requirements for an outage valve or a fixed liquid level gauge.
  - (2) **Two or More Containers.** When two or more containers are used, a backflow check valve shall be installed in each fuel line to prevent passing of fuel between tanks during filling operations. A hydrostatic relief valve with a pressure setting not lower than 350 psi nor higher than 500 psi shall be installed

between the backflow check valves and the fuel cutoff valve to the carburetor and between two positive liquid shut-off points in the liquid piping and hose.

- (3) **Identification Markings.** An LPG fuel supply container shall be permanently marked as follows:
  - (i) Markings on the containers constructed to the ASTM Code shall include all the following:
    - (A) An official ASME Code U symbol.
    - (B) The manufacturer’s name, initials or trademark.
    - (C) The maximum allowable working pressure (psi at F).
    - (D) The serial number.
    - (E) The year built.
    - (F) The words “FOR LP GAS ONLY” in letters not less than 1/4 inch high and visible after installation. Decals are acceptable.
  - (ii) Permanent markings on containers constructed to DOT regulations shall include:
    - (A) The letters “DOT” or “ICC” with the appropriate specification and service pressure.
    - (B) The serial number.
    - (C) The year tested.
    - (D) The manufacturer’s name, initials, or trademark, as registered with DOT.
    - (E) The words “FOR LP GAS ONLY” or “FOR LPG ONLY” in letters not less than 1/4 inch high and visible after installation. Decals and stencils are acceptable.
  - (iii) A container inlet and outlet except those for relief valves and gauging devices shall be marked to designate whether they communicate with vapor or liquid space.
- (4) **Valves.** A valve shall be of a type that has been tested and listed by UL or by other nationally recognized testing laboratories as meeting the UL requirements for LPG. All valves shall be securely mounted and shielded or installed in a protected location to prevent damage from vibration and unsecured objects.
  - (i) **Safety Relief Valves.** One or more spring-loaded internal safety valves shall be installed directly in each fuel container in communication with the vapor space. The markings showing “set to discharge pressure” shall be visible after the valves are installed in the container. Safety relief valves for DOT fuel supply containers shall be approved by the Bureau of Explosives, and the valve setting shall be as required by the Bureau. The safety relief valve setting shall be as required by the Bureau. The safety relief valve setting for ASME containers shall not be less than 100% nor more than 110% of the maximum allowable service pressure of the container.
    - (A) Safety relief valves for ASME fuel containers shall be so constructed so as to discharge at not less than the following rates before the pressure is in excess of 120% of the maximum allowable working pressure of the container:

TANK SURFACE AREA (sq ft.)	AIR FLOW RATE(cfm)
20 or less . . . . .	626
25 . . . . .	751
30 . . . . .	872
35 . . . . .	990
40 . . . . .	1,100
45 . . . . .	1,220
50 . . . . .	1,330
55 . . . . .	1,430
60 . . . . .	1,540
65 . . . . .	1,640
70 . . . . .	1,750
75 . . . . .	1,850
80 . . . . .	1,950
85 . . . . .	2,050

90	2,150
95	2,240
100	2,340
105	2,440
110	2,530
115	2,630
120	2,720
125	2,810
130	2,900
135	2,990
140	3,080
145	3,170
150	3,260
155	3,350
160	3,440
165	3,530
170	3,620
175	3,700
180	3,790
185	3,880
190	3,960
195	4,050
200	4,130

(B) Permanent markings on safety relief valves in ASME containers shall include all of the following:

- (I) The manufacturer's name, initials, or trademark.
- (II) The manufacturer's design or type numbers.
- (III) The discharge pressure (\_\_\_psi).
- (IV) The discharge capacity (cfm air at 60°F and 14.7 psia).
- (V) The ASME or UL symbol.

(C) Permanent markings on safety relief valves in DOT containers shall include all of the following:

- (I) The manufacturer's name, initials, or trademark.
- (II) The catalog number.
- (III) The discharge pressure (\_\_\_psi).
- (IV) The discharge capacity (cfm air at 60°F and 14.7 psia).

- (ii) **Excess Flow Valve.** An internal excess flow valve, designed to close when maximum volume escapes through the smallest connection in the supply line system, shall be installed in every fuel supply container outlet except the relief valve or gauging device outlets. The excess flow valve shall have a bypass not to exceed a Number 60 drill size opening to allow equalization of pressure.
- (iii) **Check Valve.** Inlet connections in the fuel supply container shall be fitted with an internal and external check valve or an internal check valve with an adjacent or remote manual shut off valve. The inlet of the filling system shall be capped, except when filling, to withstand the maximum service pressure of the container. A container installed after January 1, 1973 shall be equipped for remote filling exterior to the vehicle compartment with an internal and external check valve installed in the container.
- (iv) **Shut-off valve.** A manually operated shut-off valve shall be installed directly into the fuel supply container outlet connection serving the supply line and shall be marked with the words, "SHUT-OFF VALVE." Decals or stencils are acceptable.

(5) **Gauge.** An LPG containers shall be equipped with a liquid volume gauge, which shall be designed and installed as follows:

- (i) The gauging device shall be of a type that has been listed by UL or by other nationally recognized testing laboratories as meeting the UL requirements for LPG.
  - (ii) The gauge shall be securely mounted and shielded or installed in a protected location to prevent damage from excessive vibration and unsecure objects.
  - (iii) A gauge that requires bleeding of the product shall be bled to outside of the vehicle compartment and shall be equipped with a bleeder valve. A restricting orifice not larger than Number 54 drill size shall be inside the fuel supply container.
- (6) **Vaporizer and pressure reducing regulator.** Devices which supply heat directly to the fuel container shall be equipped with an automatic device to cut off the supply of heat before the pressure in the container reaches 200 psig. A vaporizer shall be fabricated of materials suitable for LPG service and resistant to any action of the LPG under service conditions. Such vaporizers shall be designed for engine fuel service and shall comply with the following:
- (i) The vaporizer, any part of it, or any devices used with it which may be subjected to container pressure shall have a design pressure of at least 250 psig and shall be plainly and permanently marked at a readily visible point:
    - (A) With the design pressure of the fuel containing portion in psig.
    - (B) With the water capacity of the fuel-containing portion in pounds.
  - (ii) A vaporizer shall not be equipped with fusible plugs.
  - (iii) A vaporizer shall have a valve or suitable plug located at or near the lowest portion of the section occupied by the water or other heating liquid to permit substantially complete drainage. The engine cooling system drain or water hoses may serve this purpose, if effective.
  - (iv) Vaporizers and regulators shall be securely fastened in position.
  - (v) Engine exhaust gases may be used as a direct source of heat to vaporize the fuel if the materials of construction of those parts of the vaporizer in contact with the exhaust gases are resistant to corrosion from these gases and if vaporizer system is designed to prevent excessive pressures.
  - (vi) Approved automatic pressure- reducing equipment, properly secured, shall be installed between the fuel supply container and the gas air mixer to regulate the pressure of the fuel delivered to the gas-air mixture.
  - (vii) An approved automatic shut-off valve shall be installed in the fuel system at some point ahead of the inlet of the gas regulator, designed to prevent the flow of fuel to the gas-air mixer when the engine is not running. Atmospheric type regulators—zero governors—shall not be considered as automatic shut-off valves.
- (7) **Vents.** A compartment in which an LPG container is installed shall be vented to the atmosphere unless all piping and connectors are exterior to the compartment. The vent or vents shall be installed at the lowest practicable point of the compartment and shall have an open area totaling not less than 3 square inches.
- (8) **LPG hose for high pressure liquid or vapor use.** The hose and hose assemblies shall have a working pressure of not less than 350 psi and a burst pressure of not less than 1750 psi. The hose shall be reinforced with corrosion-resistant wire braid and shall be of a type that has been tested and listed by UL or by other nationally recognized testing laboratories as meeting the UL requirements for LPG. Hose shall have the following permanent identification markings in letters and numerals at least 1/5 inch in height at intervals of 24 inches or less:
- (i) The manufacturer's name, initials, or trademark,
  - (ii) LPG or LP GAS
  - (iii) The working pressure
  - (iv) The burst pressure
- (9) **Hydrostatic Relief Valve.** Hydrostatic relief valves designed to relieve the hydrostatic pressure that might develop shall be installed in sections of piping or hose between closed shut-off valves and have a pressure setting of not less than 350 psig, or more than 500 psig.

- (c) **Compressed Natural Gas** - A fuel system using compressed natural gas (CNG) shall meet the following requirements in addition to those in subsection (e):
- (1) **Fuel Supply Container.** A CNG fuel supply container shall be constructed and inspected in accordance with DOT regulations and shall have a rated service pressure of not less than 2250 psi at 70°F. It shall not be filled beyond the working pressure stamped on the tank and marked near the filler connection, corrected for the ambient temperature at time of filling as prescribed by DOT.
  - (2) **Identification Markings.** Each CNG fuel supply container shall have the following identification markings:
    - (i) The letters “DOT” with the appropriate specification and working pressure.
    - (ii) The serial number.
    - (iii) The year tested.
    - (iv) The manufacturer’s name, initials, or trademark.
    - (v) The words “FOR CNG ONLY” in letters at least 1/4 inch high and visible after installation. Decals or stencils are acceptable.
  - (3) **Shut-Off Valve.** A manually operated shut-off valve shall be in direct communication with the container and shall be marked with the words, “SHUT-OFF VALVE.” Decals or stencils are acceptable. A normally closed automatic shut-off valve that is held open by electrical current may be used in addition to a manual shut-off valve and shall be marked with the words, “AUTOMATIC SHUT-OFF VALVE.” The automatic shut-off valve shall be wired so that it shuts off when the ignition switch is in the off or accessory positions or when engine vacuum or oil pressure is not present. A valve may not be used for CNG unless it has been certified for that purpose by the manufacturer. The shut-off valve shall be securely mounted and shielded or installed in a protected location to prevent damage from vibration and unsecured objects.
  - (4) **Safety Relief Valve.** One or more safety relief devices shall be installed in the fuel supply container in communication with the fuel and vented to the outside of the vehicle compartment. A relief device shall be approved as to type, size, quantity and location by the Bureau of Explosives and shall have the following permanent identification markings:
    - (i) The manufacturer’s name, initials or trademark.
    - (ii) The flow capacity (\_\_\_\_cf).
    - (iii) The yield temperature rating (\_\_\_\_F).
  - (5) **Gauges.** Gauges used in CNG systems shall be designed and installed as follows:
    - (i) A gauging device shall be designed for the most severe pressure and temperature conditions to which the devices may be subjected with a pressure safety factor of not less than four.
    - (ii) Gauges shall be securely mounted and shielded or installed in a protected location to prevent damage from vibration and unsecured objects.
  - (6) **Pressure Reducing Regulators.** An automatic pressure reducing regulator shall be installed in CNG systems to reduce container pressure to a value consistent with the working pressure required by the carburetor. Means shall be provided to prevent malfunction due to refrigeration effects. Regulators shall be installed so that their weight is not placed on or supported alone by the attaching lines. Regulators shall be designed to a container’s maximum working pressure and temperature with a pressure safety factor of not less than four.
  - (7) **Vents.** Every compartment in which a CNG container is installed shall be vented to the atmosphere, unless all piping and connections are exterior to the compartment or vapor sealed and vented to the atmosphere. The vents shall be installed at the highest practicable point of the compartment and shall have an open area totaling not less than 3 square inches.
- (d) **Liquefied Natural Gas** - A fuel system using liquefied natural gas (LNG) shall meet the following requirements in addition to those in subsection (e):
- (1) **Fuel supply container.** An LNG fuel supply container shall be constructed and inspected in accordance with 49 CFR §178.57 (relating to specification 4L; welded cylinders insulated), specification 4L for welded insulated cylinders, with the exception of 49 CFR 178.57-13 and 178.57-20 (relating to pressure relief

devices pressure control valves; and markings) and the report to the Bureau of Explosives in §178.57-4(d) (relating to duties of inspector). Each LNG container shall meet the following additional requirements:

- (i) The unrelieved fuel pressure inside the container shall not exceed 100 psi within a total 72-hour period consisting of 48 hours at 60°F and 12 hours at 90°F ambient temperatures when the container has been filled with LNG conditioned at one atmosphere.
  - (ii) The container shall be equipped with a liquid level gauging device and a dip tube to prevent filling beyond 90% by volume at atmospheric pressure.
  - (iii) Each completed container, including its supporting structure and valves, enclosures, and lines normally attached thereto, shall have structural integrity to withstand damage from deceleration and acceleration forces resulting from a 30 miles per hour front-end and rear-end collision of the type of vehicle in which the container is installed. A test or other means shall demonstrate that the container and its openings do not rupture in such collisions.
  - (iv) Each LNG fuel supply container shall have the following permanent identification markings:
    - (A) The numbers indicating the service pressure.
    - (B) The serial number.
    - (C) The manufacturer's name, initials, or trademark.
    - (D) The inspector's mark.
    - (E) The date tested.
    - (F) The words, "FOR LNG ONLY" in letters not less than 1/4 inch high and visible after installation. Decals or stencils are acceptable.
  - (v) An inlet and outlet except relief valves and gauging devices shall be marked to designate whether they communicate with vapor or liquid space.
- (2) **Valves.** A valve shall be certified for LNG use by the manufacturer or certified for cryogenic service at temperatures down to and including 320° F. A valve shall be securely mounted and shall be shielded or installed in a protected location to prevent damage from vibration and unsecured objects.
- (i) **Safety Relief Valve.** A container shall be equipped with one or more safety relief valves. The safety relief valve shall be installed in a line that communicates with the vapor space of the container. A safety relief valve shall be installed between two shut-off valves in a supply line to prevent a buildup of pressure between the valves in the off position. The discharge pressure of safety relief valves shall not exceed 125% of the service pressure of the container. A relief valve shall have sufficient capacity to meet the requirement of either the Bureau of Explosives for approval of safety relief valves or NFPA 59(A) Appendix A and be capable of preventing explosion of the normally charged cylinder when it is placed in a fire. A relief valve shall have the following permanent identification markings:
    - (A) The manufacturer's name, initials or trademark.
    - (B) The catalog number.
    - (C) The discharge pressure (\_\_\_\_psi).
    - (D) The discharge capacity (\_\_\_\_cfm air at 60°F and 14.7 psia).
  - (ii) **Shut-Off Valves.** One manually operated shut-off valve shall be secured directly to the tank vapor outlet with no intervening fitting other than the relief valve and shall be marked with the words, "VAPOR SHUT-OFF VALVE." Another manually operated shut-off valve and shall be secured directly to the tank liquid outlet and shall be marked with the words, "LIQUID SHUT-OFF VALVE." Decals or stencils are acceptable. Normally closed automatic shut-off valves that are held open by electrical current may be used in lieu of manual shut-off valves at either the tank vapor port or tank liquid port, or both. An automatic shut-off valve shall be wired so it shuts off when the ignition switch is in the off and accessory positions and when engine vacuum is not present.
  - (iii) **Control Valve.** A positive shut-off control valve shall be installed in the fuel supply lines as close to the containers as possible, automatically closing off and preventing the flow of fuel to the carburetor when the ignition switch is off or in the accessory position.

- (3) **Gauges.** Gauges used in LNG systems shall be designed and installed as follows:
- (i) A gauging device shall be designed for the most severe pressure and temperature conditions to which the devices may be subjected with a pressure safety factor of not less than four.
  - (ii) The gauges shall be securely mounted and shall be shielded or installed in a protected location to prevent damage from vibration and unsecured objects.
  - (iii) A gauging device that requires bleeding of the product shall be bled to the outside of the vehicle compartment.
- (4) **Pressure Reducing Regulators.** An LNG system shall be equipped with one- or two-stage pressure-reducing regulators. The regulators shall be installed so that their weight is not placed on or supported alone by the attaching tubing or flexible lines.
- (5) **Vents.** A compartment in which an LNG container is installed shall be vented to the atmosphere unless all piping and connectors are exterior to the compartment. The vents shall be installed at the highest practicable point of the compartment and shall have an open area totaling not less than 3 square inches.
- (e) **Installation -** The installation of liquefied petroleum gas, compressed natural gas or liquefied natural gas fuel systems on motor vehicles shall be in accordance with the following requirements:
- (1) **Driver, passenger, and luggage compartments.** A fuel supply container on a bus may not be located in or above the passenger compartment, except that a fuel supply container for compressed natural gas may be located above the driver and passenger compartment(s).  
  
A fuel supply container on a vehicle shall be installed and fitted so that no gas from fueling and gauging operations or from relief valves can be released inside the driver, passenger or luggage compartments.
  - (2) **Fuel Supply Containers -** A fuel supply container shall meet all appropriate requirements of the ASME code, the DOT regulations, and this chapter and shall be marked in accordance with subsections (b) - (d). A fuel supply container shall comply with the following requirements:
    - (i) Each container and container cradle shall be mounted in protected locations to minimize damage from collision.
    - (ii) To prevent damage from road hazards, slippage, loosening or rotation, each container or cradle shall be secured to the vehicle body, bed or frame by:
      - (A) Attaching bolts not less than 7/16 inch in diameter to at least four securement points and, where the bolts pierce body metal but not the frame, by reinforcing both sides of each securement point with metal plates at least 1/5 inch thick and 7 square inches in area.
      - (B) Using other means capable of withstanding in any direction a static force of eight times the weight of the fully loaded container.
    - (iii) Each container in a cradle shall be secured to its cradle by means capable of withstanding in any direction a static force of eight times the weight of the fully loaded container.
    - (iv) No portion of the container or container valves in communication with the liquid or vapor shall be located behind the rear frame crossmember of the vehicle.
    - (v) The weight of the container shall not in any way be supported by outlets, valves, manifold or other fuel connections.
    - (vi) No part of the container shall be field welded. Only saddle plates, brackets or other nonpressure parts that were provided and installed by the manufacturer of the container may be field welded.
    - (vii) No container shall be repaired until the contemplated repair has been authorized by a certified inspector. A DOT container shall be repaired under DOT regulations and control. The replacement of valves, fittings and accessories intended for the same purpose is not considered a repair.
    - (viii) A container located less than 8 inches from the engine or exhaust system shall be shielded against direct heat.
    - (ix) Where a container is installed above the driver or passenger compartment of a vehicle, the container, its piping, fittings and valves shall be protected from damage by:
      - (A) A guardrail or similar device which is designed to absorb the impact of a collision with a

stationary object when the vehicle is moving either forward or backward at 8 kilometers per hour (5 miles per hour). The guardrail, or similar device, shall be free of projections that could damage the container, its valves and fittings.

- (B) A shield designed to absorb impacts that may occur during loading, unloading or use of the vehicle. The shield shall be free of projections that could damage the container, its valves and fittings.
- (x) A part of a fuel container or its appurtenances may not project beyond the sides and ends or above the highest structural point of a vehicle.
- (xi) The devices, bolts and nuts attaching a fuel container to the outside of a vehicle shall have a corrosion resistant coating.
- (3) **Visibility of Required Markings.** Markings of set-to-discharge pressure for safety relief devices and working pressure of fuel supply containers required by subsections (b), (c), and (d) shall be visible either directly or by use of a mirror after installation. Remote filling inlets shall be visibly marked with the lowest working pressure of any fuel supply container in the system.
- (4) **Discharge Lines and Outlets.** All safety devices that may discharge to the atmosphere shall be vented to the outside of the vehicle, and all discharge lines and outlets shall be installed as follows:
- (i) Lines shall be constructed of metal other than aluminum and shall be of a size and so located and maintained as not to restrict the maximum gas flow of the safety device. Flexible metallic lines shall be used when necessary.
  - (ii) The discharge line of a container installed inside a compartment shall extend to the outside of the compartment.
  - (iii) Lines shall be located as far from the exhaust outlet as is practicable and shall direct escaping gas upward within 45 degrees of the vertical. Escaping gas shall not impinge upon fuel supply containers and shall not be directed into wheel wells, at other vehicles in traffic, or at engine air intake inlets.
  - (iv) The discharge line from the safety relief valve on all buses shall be directed upward and extended to the top of the roof.
  - (v) Outlets shall be protected by caps, covers or other means to keep water or dirt from collecting in the lines. Protective devices shall not restrict the flow of gas.
  - (vi) Each line and its connectors shall withstand the pressure caused by the discharge of vapor or liquid from a safety device in fully open position.
  - (vii) A CNG container may be vented to the outside of the vehicle with a flexible bag. The bag shall be constructed of material that is non-flammable or self-extinguishing. The bag and attachments shall be capable of withstanding an internal pressure produced by a flow rate of 300 cfm with a safety factor of not less than four. The bag shall be shielded or installed in a protected location to prevent damage from unsecured objects and abrasion.
- (5) **Manifolds.** Manifolds connected to fuel containers shall be supported to minimize vibration and shall be installed in a protected location or shielded to prevent damage from unsecured objects.
- (i) A manual shut-off valve shall be installed in the outlet of the manifold and marked with the words "MANUAL SHUT-OFF VALVE." Decals or stencils are acceptable.
  - (ii) A normally closed automatic shut-off valve that is held open by electrical current may be used in lieu of a manual shut-off valve and shall be marked with the words, "AUTOMATIC SHUT-OFF VALVE." The automatic shut-off valve shall be wired so it shuts off when the ignition switch is in the off or accessory positions and when engine vacuum is not present.
- (6) **Pipes, Tubing, Hose and Fittings.** Pipes, tubing, hose and fittings shall meet the following requirements:
- (i) Materials and assemblies shall be designed for the widest pressure and temperature ranges to which they may be subjected with a pressure safety factor of at least four.
  - (ii) Materials, including gasket and packing material, shall be compatible with the fuel used in the system and its service conditions. Aluminum pipe, tubing or fittings shall not be used between the container and first-stage regulator. Copper tubing, when used, shall be seamless and conform to



ASTM B88 types K or L.

- (iii) A pipe thread sealant impervious to the action of the fuel used in the system shall be applied to all male pipe threads prior to assembly. Only tin-silver (95% tin, 5% silver) or silver braze alloy is permitted on sweat type joints of fittings.

(7) **Supply Lines.** Supply lines passing through a panel shall be protected by grommets or similar devices, which shall snugly fit both the supply lines and the holes in the panel. Supply lines shall have a minimum clearance of 8 inches from the engine exhaust system unless they are shielded from exhaust heat. Supply lines shall be supported at least every 24 inches and shall be prevented from sagging. Damaged lines shall be replaced, not repaired.

(8) **Automatic Fuel Supply Shut-Off.** An automatic fuel supply shut-off valve shall be installed in a protected location adjacent to the manual shut-off valve on all buses and shall be activated by engine vacuum or oil pressure.

(9) **Gaseous Fuel Cutoff.** Means shall be provided in the system to prevent the flow of gaseous fuel to the carburetor when the ignition is in the off or accessory position or from the carburetor when engine vacuum is not present.

(10) **Liquid Fuel Cutoff.** A dual fuel systems using liquid and gaseous fuel shall have an approved automatic shut-off valve installed in the liquid fuel line to the carburetor.

(11) **Bypass Relief Valve.** A bypass relief device shall be installed in the fuel pump or between the fuel pump and the automatic shut-off valve in the liquid fuel line to the carburetor on vehicles equipped with dual fuel systems for the use of gasoline and gaseous fuel. The relief device need not be installed on fuel pumps containing a bypass relief device as original equipment.

(12) **Engine Exhaust Outlet.** The engine exhaust system shall extend to the outer edge of the vehicle body or bed on passenger cars, station wagons, house cars, pickup trucks with campers, buses, and delivery vans.

(13) **Electrical Equipment.** Radio transmitters, radio receivers, electric motors or other electrical equipment except vehicle lamps and wiring shall not be mounted in a compartment with fuel supply containers unless one of the following conditions is met:

- (i) All piping and all connectors and valves on the fuel supply containers are exterior to and sealed from the compartment containing electrical equipment.
- (ii) All piping, connectors and valves within the compartment are contained in a vapor-tight enclosure and vented to the atmosphere exterior of the vehicle.
- (iii) The electrical equipment is contained in a vapor-tight enclosure that is vented to the atmosphere exterior of the vehicle.

(14) **Road Clearance.** The fuel system including the fuel supply container shall be installed with as much road clearance as practicable but not less than the minimum road clearance of vehicle under maximum spring deflection. The clearance shall be measured to the bottom of the container or to the lowest fitting, support or attachment on the container or container housing, whichever is lower.

(15) **Vehicle Weight Distribution.** The total weight of the vehicle with the fuel containers filled to capacity may not do one or more of the following:

- (i) Exceed the manufacturer's load rating for an axle, wheel or tire, or gross weight limitations.
- (ii) Create another unsafe load distribution that would increase the risk of a hazardous operating condition, such as vehicle rollover.
- (iii) Adversely affect the driving characteristics of the vehicle.

### 175.242. Inspection of Fuel System and Controls

Alternate Fuel Systems - LNG, CNG, LPG-include approved and marked supply containers and valves, gauges, vaporizers, regulators, vents, hoses, and manifolds. The components of the alternate fuel system shall be inspected. The vehicle shall be **REJECTED IF** the alternate fuel system does not comply with all applicable requirements of §175.241 (relating to compressed and liquefied gas fuel systems).

## Subchapter O

### VEHICLE SUN SCREENING DEVICES

#### 175.261. Scope

This subchapter governs the application upon windows and wings, except roof locations, of sun screening devices, and other material which do not permit a person to see or view the inside of the vehicle, and which do not comply with FMVSS No. 205, and the application for a certificate of exemption from the provisions of this subchapter.

#### 175.262. Applicability

This subchapter applies to vehicles which are subject to a periodic safety inspection, except those inspected in accordance with §175.130 (relating to inspection procedure).

#### 175.263. Sun Screening Location

- (a) **Windshields, Side Windows and Side Wings** - A person may not operate, on a highway, a motor vehicle with a front windshield, side window or side wing that has been equipped with a sun screening device or other material which does not permit a person to see or view the inside of the vehicle. This subchapter does not prohibit the use of products or material along the top edge of the windshield if the products or materials are transparent and do not encroach upon the AS-1 portion of the windshield as provided by FMVSS No. 205 and if the devices or materials are not more than 3 inches from the top of the windshield.
- (b) **Rear Window** - The rear window on a motor vehicle may be treated by the vehicle owner with a sun screening device or other material. If the rear window is treated with a sun screening device or other material, the vehicle shall comply with §175.264 (relating to mirrors). See Table X for specific requirements for vehicles subject to this subchapter).
- (c) **Louvered Materials** - Louvered materials, may not reduce the area of driver visibility below 50% as measured on a horizontal plane.

#### 175.264. Mirrors

Right and left outside rearview mirrors shall be required with the use of a sun screening device or other material unless the sun screening device or other material is only used or applied above the AS-1 portion of the windshield as permitted in §175.263(a) (relating to sun screening location). Each mirror shall have a minimum reflective surface of 19.5 square inches, except as otherwise provided in §175.148(b) and §175.177(b) (relating to mirrors). A vehicle for which a certificate of exemption has been issued for medical reasons may be equipped with only a left outside rearview mirror, unless originally equipped with an outside rearview mirror on both sides of the vehicle.

#### 175.265. Exemption provisions

- (a) **Exempt Vehicles** - The following vehicles are exempt from §175.263 (relating to sun screening location):
  - (1) A hearse, ambulance or government vehicle.
  - (2) A vehicle for which a certificate of exemption has been issued by the Department under subsection (b).
- (b) **Certificate Of Exemptions** - The Department will issue a certificate of exemption from §175.263 for the following vehicles:
  - (1) A vehicle which was registered in this Commonwealth as of September 8, 1984, and was equipped with a prohibited sun screening device or other prohibited material prior to September 9, 1984. Requests for this type of exemption shall be accompanied by an application for a certificate of exemption, made on a form furnished by the Department, which shall contain a description of the vehicle by make, year, model, vehicle identification number, windows and wings equipped with sun screening device or other material and other information as the Department may prescribe.
  - (2) A vehicle owned by a person who is afflicted with a condition for which the Department has determined, in consultation with a Medical Advisory Board, that the use of prohibited sun screening devices or other materials is justified; or a vehicle owned by a person residing with a person who is so afflicted, if the afflicted person normally drives or is driven in the vehicle. An application for a certificate of exemption

## Subchapter O - Vehicle Sun Screening Device

---

shall be granted only for colorless sun screening device or other material and shall be made on a form furnished by the Department, which shall contain the following:

- (i) A description of the vehicle by make, year, model and vehicle identification number.
  - (ii) A medical certification of need due to a disability from a licensed physician or optometrist.
  - (iii) Other information as the Department may prescribe.
- (c) **Display Of Certificate Issued For Vehicles Registered As Of September 8, 1984** - Upon compliance with the criteria in subsection (b)(1), the Department will issue a certificate of exemption which shall be carried in the vehicle at all times by the operator of the vehicle and shall be displayed upon request of a police officer. The certificate of exemption shall also be submitted to the inspection station upon submission of the vehicle for inspection.
- (d) **Display Of Certificate Issued For Medical Reasons** - Upon compliance with the criteria listed in subsection (b)(2), the Department will issue a certificate of exemption authorizing the installation of a colorless sun screening device or other material which filters ultraviolet light. This certificate of exemption shall be carried in the vehicle at all times by the operator of the vehicle and shall be displayed upon request of a police officer. The certificate of exemption shall also be submitted to the inspection station upon submission of the vehicle for inspection.
- (e) **Sale Or Transfer Of Exempted Vehicle** - Upon the sale or transfer of a vehicle for which a certificate of exemption has been issued under subsection (b)(2), the certificate of exemption is void. Prior to the sale or transfer of a vehicle exempted under subsection (b)(2), it is the sole responsibility of the owner or seller of the vehicle to remove sun screening devices or other materials which do not comply with Departmental regulations. The owner or seller shall destroy the certificate of exemption and provide the purchaser with a notarized statement specifying the name and address of the owner or seller, the vehicle identification number, year and model, and the business entity and process used to remove the sun screening device or other material.

**TABLE I**  
**Brake Performance**

Passenger carrying vehicles with seating capacity of 10 persons or less and built on passenger frame:

	<b>SERVICE BRAKE SYSTEM</b>		<b>EMERGENCY BRAKE</b>
Percent braking force	Deceleration in feet/seconds	Stopping distance in feet at 20 MPH	Stopping distance in feet at 20 MPH
65.2	21	20	54

Passenger carrying vehicles with seating capacity of over 10 persons built on passenger car chassis; vehicles built on truck or bus chassis with manufacturer's gross weight of 10,000 pounds or less:

Percent braking force	Deceleration in feet/seconds	Stopping distance in feet at 20 MPH	Stopping distance in feet at 20 MPH
52.8	17	25	66

All other passenger carrying vehicles:

Percent braking force	Deceleration in feet/seconds	Stopping distance in feet at 20 MPH	Stopping distance in feet at 20 MPH
43.5	14	35	85

Property-carrying vehicles having manufacturer's gross weight of 10,000 pounds or less:

Percent braking force	Deceleration in feet/seconds	Stopping distance in feet at 20 MPH	Stopping distance in feet at 20 MPH
52.8	17	25	66

Single property-carrying vehicles having manufacturer's gross weight over 10,000 pounds except truck tractors. Combinations of 2-axle towing vehicle and trailer having GVRW of 3,000 pounds or less:

Percent braking force	Deceleration in feet/seconds	Stopping distance in feet at 20 MPH	Stopping distance in feet at 20 MPH
43.4	14	35	85

All other property-carrying vehicles and combinations of property carrying vehicles:

Percent braking force	Deceleration in feet/seconds	Stopping distance in feet at 20 MPH	Stopping distance in feet at 20 MPH
43.5	14	40	90

**TABLE II**  
**Required Motor Vehicle Lighting Equipment**  
 (as adopted in Chapter 153)

<b>ITEM</b>	<b>MULTI-PURPOSE PASSENGER VEHICLES, TRUCKS AND BUSES-80" OR MORE OVERALL WIDTH</b>
Headlamps . . . . .	.2 white, 7" Type 2 headlamp units or 2 white, 5 ¾" Type 1 headlamp units and 2 white, 5 ¾" Type 2A headlamp units and 2 white, Type 1A headlamp units.  2 white headlamps, Type 2B1 or Type 2D1; or 4 white headlamps; 2 each Type 1C1 and Type 2C1, Type 2A1.
Taillamps . . . . .	.2 red
Stoplamps . . . . .	.2 red
License Plate Lamp . . . . .	.1 white
Reflex Reflectors . . . . .	.4 red; 2 amber
Side Marker Lamps . . . . .	.2 red; 2 amber
Backup Lamp . . . . .	.1 white
Turn Signal Lamps . . . . .	.2 red or amber; 2 amber
Turn Signal Operating Unit . . . . .	.1
Turn Signal Flasher . . . . .	.1
Vehicular Hazard Warning Signal Operating Unit . . . . .	.1
Vehicular Hazard Warning Signal Flasher . . . . .	.1
Identification Lamps . . . . .	.3 amber; 3 red
Clearance Lamps . . . . .	.2 amber; 2 red
Intermediate SideMarker Lamp . . . . .	.2 amber
Intermediate ReflexReflectors . . . . .	.2 amber

**TABLE III**  
**Location of Required Equipment**

Multi-purpose Passenger Vehicles, Trucks, Trailers and Buses-80" or More Overall Width

<b>ITEM</b>	<b>LOCATION ON</b>	<b>Height above road surface measured from center of item on vehicle</b>
	<b>Multi-purpose passenger vehicles, trucks and buses</b>	
Headlamps . . . . .	Type 1 headlamps at the same height. . . . . 1 on each side of the vertical centerline. Type 2 headlamps at the same height. 1 on each side of the vertical centerline, as far apart as practicable.	Not less than 24" nor more than 54"
Taillamps . . . . .	On the rear, 1 on each side of the vertical centerline, . . . . . at the same height, and as far apart as practicable.	Not less than 15" nor more than 72"
Stoplamps . . . . .	On the rear, 1 on each side of the vertical centerline, . . . . . at the same height, and as far apart as practicable.	Not less than 15" nor more than 72"
License Plate Light .	At rear license plate, to illuminate the plate from the . . . . . top or sides.	No Requirement
Backup Lamp . . . . .	On the rear . . . . .	No Requirement
Turn Signal Lamps .	At or near the front 1 amber on each side of the vertical . . . . . centerline, at the same height and as far apart as practicable. On the rear 1 red or amber on each side of the vertical centerline, at the same height, and as far apart as practicable.	Not less than 15" nor more than 83"
Identification . . . . . Lamps	On the front and rear 3 lamps, amber in front, red in rear, . . . . . as close as practicable to the top of the vehicle, at the same height as close as practicable to the vertical centerline, with lamp centers spaced not less than 6" or more than 12" apart.	No Requirements
Clearance Lamps . .	On the front and rear 2 amber lamps on front, red in rear, . . . . . as close as practicable to the top of the vehicle, 1 on each side of the vertical centerline, at the same height, and as near the top as practicable.	No Requirements
Intermediate Side . . Marker Lamps	On each side 1 amber located at or near the midpoint . . . . . between the front and rear side marker lamps.	Not less than 15"
Intermediate Side . . Reflex Reflectors	On each side 1 amber located at or near the midpoint . . . . . between the front and rear side reflex reflector.	Not less than 15" nor more than 60"
Reflex Reflectors . .	On the rear 1 red on each side of the vertical center- . . . . . line, as far apart as practicable, and at the same height.	Not less than 15" nor more than 60"
Side Marker . . . . . Lamps	On each side 1 red as far to the rear as practicable, . . . . . and 1 amber as far to the front as practicable.	Not less than 15" and on the rear of trailers not more than 60"

**TABLE IV**  
**Required Motor Vehicle Lighting Equipment**  
 (as adopted in Chapter 153)

<b>ITEM</b>	<b>PASSENGER CARS, MOTORCYCLES AND MULTI-PURPOSE VEHICLES, TRUCKS, TRAILERS, AND BUSES OF LESS THAN 80" OVERALL WIDTH</b>
Headlamps . . . . .	.2 white, 7", Type 2 headlamp units or 2 white 5¾", Type 1 headlamp units or 2 white 5¾" Type 2A headlamp units and 2 white Type 1A headlamp units.  2 white headlamps, Type 2B1 or Type 2D1; 4 white headlamps, 2 each Type 1C1 and Type 2C1, or Type 1A1 and Type 2A1.
Taillamps . . . . .	.2 red
Stoplamps . . . . .	.2 red
License Plate Light . . . . .	.1 white
Parking Lamps . . . . .	.2 amber or white
Reflex Reflectors . . . . .	.4 red; 2 amber
Intermediate Side Reflex Reflectors . . . . .	.2 amber
Intermediate Side Marker Lamps . . . . .	.2 amber
Side Marker Lamps . . . . .	.2 red; 2 amber
Backup Lamp . . . . .	.1 white
Turn Signal Lamps . . . . .	.2 red or amber
Turn Signal Operating Unit . . . . .	.1
Turn Signal Flasher . . . . .	.1
Vehicular Hazard Warning Signal Operating Unit . . . . .	.1
Vehicular Hazard Warning Signal Flasher . . . . .	.1

**TABLE V**  
**Location of Required Equipment**

MOTORCYCLES

ITEM	LOCATION ON MOTORCYCLES	Height above road surface measured from center of item on vehicle
Turn Signal Lamps	<p>At or near the front 1 amber on each side of the vertical centerline at the same height, and having a minimum horizontal separation distance (centerline of lamps) of 16". Minimum edge to edge separation distance between lamp and headlamp is 4".</p> <p>At or near the rear 1 red or amber on each side of the vertical centerline, at the same height and having a minimum horizontal separation distance (centerline to centerline of lamps) of 9". Minimum edge to edge separation distance between lamp and tail or stop lamp is 4".</p>	Not less than 15" nor more than 83"
<p><b>NOTE:</b> A portion of Table V was inadvertently omitted from the official text of Chapter 175. The remainder of Table V is as follows:</p>		
Headlamps	On the vertical centerline, except if two are used, they shall be symmetrically disposed about the vertical centerline.	Not less than 24" nor more than 54"
Taillamps	On the rear, on the vertical centerline except that if two are used, they shall be symmetrically disposed about the vertical centerline.	Not less than 15" nor more than 72"
Stoplamps	On the rear, on the vertical centerline except that if two are used, they shall be symmetrically disposed about the vertical centerline.	Not less than 15" nor more than 72"
License Plate Lamp	At rear license plate	No Requirement
Reflex Reflectors	On the rear 1 red on the vertical centerline except that if two are used on the rear, they shall be symmetrically disposed about the vertical centerline. On each side, 1 red as far to the rear as practicable, and 1 amber as far to the front as practicable.	Not less than 15"

(Table V continued on next page)



**TABLE V - Location of Required Equipment (continued)**

PASSENGER CARS, MULTI-PURPOSE PASSENGER CARS, TRUCKS, TRAILERS,  
AND BUSES OF LESS THAN 80" OVERALL WIDTH

ITEM	LOCATION ON Passenger Cars, Multi-Purpose Passenger Cars, Trucks, Trailers and Buses	Height above road surface measured from center of item on vehicle
Turn Signal Lamps	At or near the front 1 amber on each side of the vertical centerline, at the same height, and as far apart as practicable.  On the rear, 1 red or amber on each side of the vertical centerline, at the same height, and as far apart as practicable.	Not less than 15" nor more than 83"  Not less than 15" nor more than 83"
Headlamps	Type 1 headlamp at the same height, 1 each side of the vertical centerline, at the same height, and as far apart as practicable.	Not less than 24" nor more than 54"
Taillamps	On the rear, 1 on each side of the vertical centerline, at the same height, and as far apart as practicable.	Not less than 15" nor more than 72"
Stoplamps	On the rear, 1 on each side of the vertical centerline, at the same height, and as far apart as practicable.	Not less than 15" nor more than 72"
License Plate Light	At rear license plate, to illuminate the plate from the top or sides.	No Requirement
Reflex Reflectors	On the rear, 1 red on each side of the vertical centerline, at the same height, and as far apart as practicable. On each side, 1 red as far to the rear as practicable, and 1 amber as far to the front as practicable.	Not less than 15" nor more than 60"
Parking Lamps	On the front, 1 on each side of the vertical centerline, at the same height, and as far apart as practicable.	Not less than 15"
Backup Lamps	On the rear	No Requirement
Side Marker Lamps	On each side, 1 red as far to the rear as practicable, and 1 amber as far to the front as practicable.	Not less than 15"
Intermediate Side Marker Lamps	On each side, 1 amber located at or near the midpoint between the front and rear side marker lamps.	Not less than 15"
Intermediate Side	On each side, 1 amber located at or near the midpoint between the front and rear side marker reflector.	Not less than 15"

\* Front Turn Signal Lamps Not Required for Trailers.

**TABLE VI**  
**Vehicle Glazing**

**ADDITIONAL GLAZING INFORMATION**

- NOTES:**
- Table below is an appendix in ANSI Glazing Standard Z26.1
  - Glazing marked AS10 or AS11 has bullet resisting qualities.
  - Acceptable numbers shown in the two columns to the right, are marked on the glass and are preceded by the letter “AS”

**Position of Glazing in Motor Vehicle Passenger Cars and Taxicabs**

	<b>Glazing Material Applicable When Marked with “AS” Designation Indicated Below</b>	
	At Levels Requisite for Driving Visibility	At Levels Not Requisite for Driving Visibility
<b>Passenger Cars:</b>		
Windshields .....	1,10	1*, 10*
Interior partitions, auxiliary wind deflectors, flexible curtains, readily removable windows, ventilators used in conjunction with readily removable windows, rear windows in tops of convertible cars. ....	1, 2, 4, 10, 11	1, 2, 3, 4, 5, 10, 11
Openings in roofs not required for driving visibility .....	1, 2, 3, 4, 5, 6, 7, 10, 11	
All other glazing .....	1, 2, 10,11	1, 2, 3, 10, 11
<b>Taxicabs:</b>		
Windshields .....	1,10	1*, 10*
Interior partitions, auxiliary wind deflectors, windows in rear doors. ....	1, 2, 4, 10, 11	1, 2, 3, 4, 5, 10, 11
Openings in roofs not required for driving visibility .....	1, 2, 3, 4, 5, 10, 11	
Flexible curtains, readily removable windows, ventilators used in conjunction with readily removable windows. ....	1, 2, 4, 6, 10, 11	1, 2, 3, 4, 5, 6, 7, 10, 11
All other glazing .....	1, 2, 10, 11	1, 2, 3, 10, 11

\* Glazing material which is intentionally made so that only a portion of a single sheet has a luminous transmittance of not less than 70 percent shall be marked at the edge of the sheet to show the limits of the area that may be used at levels requisite for driving visibility. The marks AS1 or AS2 etc., shall be used with the arrow pointing to the portion of the sheet having a luminous transmittance of not less than 70 percent and the number indicating the item with which that portion of the sheet complies.

## TABLE VII Vehicle Glazing

### ADDITIONAL GLAZING INFORMATION

- NOTES:**
- Table below is an appendix in ANSI Glazing Standard Z26.1
  - Glazing marked AS10 or AS11 has bullet resisting qualities.
  - Acceptable numbers shown in the two columns to the right, are marked on the glass and are preceded by the letter “AS”

#### Position of Glazing in Motor Vehicle Trucks and Truck-Tractors and Buses

#### Glazing Material Applicable When Marked with “AS” Designation Indicated Below

	At Levels Requisite for Driving Visibility	At Levels Not Requisite for Driving Visibility
<b>Trucks and Truck-Tractors:</b>		
Windshields	.1,10	.1*, 10*
Windows to immediate right or left of driver	.1, 2, 10, 11	.1, 2, 3, 10, 11
Rear most window if used for driving visibility	.1, 2, 10, 11	.1, 2, 3, 4, 5, 8, 9, 10, 11
Glazing to rear of driver where other means to visibility of the highway is provided	.1, 2, 3, 4, 5, 8, 9, 10, 11	.1, 2, 3, 4, 5, 8, 9, 10, 11
Folding Doors	.1, 2, 4, 8, 10, 11	.1, 2, 3, 4, 5, 8, 9, 10, 11
All other glazing	.1, 2, 10,11	.1, 2, 3, 10, 11
<b>Buses:</b>		
Windshields	.1,10	.1*, 10*
Glazing to immediate right and left of driver	.1, 2, 10, 11	.1, 2, 3, 10, 11
Rear most window if used for driving visibility	.1, 2, 8, 10,11	.1, 2, 3, 8, 9, 10, 11
Interior partitions and auxiliary wind deflectors	.1, 2, 4, 10, 11	.1, 2, 3, 4, 5, 10, 11
Folding Doors	.1, 2, 4, 8, 10, 11	.1, 2, 3, 4, 5, 8, 9, 10, 11
Standee Windows	.1, 2, 3, 4, 5, 8, 9, 10, 11	.1, 2, 3, 4, 5, 8, 9, 10, 11
Openings in roof not required for driving visibility	.1, 2, 3, 4, 5, 10, 11	.1, 2, 3, 4, 5, 10, 11
Flexible curtains readily removable windows, ventilators used in conjunction with readily removable windows.	.1, 2, 4, 6, 10, 11	.1, 2, 3, 4, 5, 6, 7, 10, 11
All other glazing	.1, 2, 3, 10, 11	.1, 2, 3, 10, 11

\* Glazing material which is intentionally made so that only a portion of a single sheet has a luminous transmittance of not less than 70 percent shall be marked at the edge of the sheet to show the limits of the area that may be used at levels requisite for driving visibility. The marks AS1 or AS2 etc., shall be used with the arrow pointing to the portion of the sheet having a luminous transmittance of not less than 70 percent and the number indicating the item with which that portion of the sheet complies.

## TABLE VIII - Vehicle Glazing

### ADDITIONAL GLAZING INFORMATION

- NOTES:**
- Table below is an appendix in ANSI Glazing Standard Z26.1
  - Glazing marked AS10 or AS11 has bullet resisting qualities.
  - Acceptable numbers shown in the two columns to the right, are marked on the glass and are preceded by the letter “AS”

**Position of Glazing in Motor Vehicle House Trailers and Property-Carrying Trailers**

**Glazing Material Applicable When Marked with “AS” Designation Indicated Below**

At Levels Requisite for Driving Visibility	At Levels Not Requisite for Driving Visibility
---	---

**House Trailers and Property-Carrying Trailers:**

All glazing . . . . .1, 2, 3, 4, 5, 6, 7, 8, 9, 10, 11

- \* Glazing material which is intentionally made so that only a portion of a single sheet has a luminous transmittance of not less than 70 percent shall be marked at the edge of the sheet to show the limits of the area that may be used at levels requisite for driving visibility. The marks AS1 or AS2 etc., shall be used with the arrow pointing to the portion of the sheet having a luminous transmittance of not less than 70 percent and the number indicating the item with which that portion of the sheet complies.

## TABLE IX - Vehicle Glazing

### ADDITIONAL GLAZING INFORMATION - MOTORCYCLES

- NOTES:**
- Table below is an appendix in ANSI Glazing Standard Z26.1
  - Glazing marked AS10 or AS11 has bullet resisting qualities.
  - Acceptable numbers shown in the two columns to the right, are marked on the glass and are preceded by the letter “AS”

**Glazing Material Applicable When Marked with “AS” Designation Indicated Below**

At Levels Requisite for Driving Visibility	At Levels Not Requisite for Driving Visibility
---	---

**Motorcycles:**

Windscreens . . . . .1\*, 6, 10\*, 11 . . . . .1, 6, 7, 10, 11

- \* Glazing material which is intentionally made so that only a portion of a single sheet has a luminous transmittance of not less than 70 percent shall be marked at the edge of the sheet to show the limits of the area that may be used at levels requisite for driving visibility. The marks AS1 or AS2 etc., shall be used with the arrow pointing to the portion of the sheet having a luminous transmittance of not less than 70 percent and the number indicating the item with which that portion of the sheet complies.

**TABLE X**  
**Acceptable Light Transmittance Levels for Vehicle Glazing**

All light transmittance levels listed below assume a 3% accuracy (+ 3%)\*

Vehicle Type	Windshield	Front Side Windows/Wings	Rear Side Windows/Wings	Rear Window
Pre-1998 Passenger Cars	70%	70%	70%	VEESC-20*
1998 & Newer Passenger Cars	70%	70%	70%	70%
Trucks & Multi-Purpose Passenger Vehicles	70%	70%	No Requirement	No Requirement
Medium/Heavy Trucks & Buses	70%	70%	No Requirement	No Requirement
All Other Vehicles	70%	70%	No Requirement	No Requirement

\* A label, permanently installed between the sun screening device or other material and the glazing to which it is applied, shall contain the name of the device or material manufacturer or a registration number and the statement, "Complies with VEESC-20."

---

## Appendix A

### MINIMUM REQUIREMENTS FOR MOTOR VEHICLE BRAKE LININGS -SAE J998

#### SAE Recommended Practice

1. **Scope** - This specification covers brake linings used on motor vehicles operated on the public ways, except those used only for parking brakes. The performance requirements outlined in this SAE Recommended Practice are based on currently available engineering data. It is intended that all portions of this recommended practice will be reviewed periodically and revised as additional knowledge regarding brake lining performance is developed.
2. **Purpose** - The purpose of this SAE Recommended Practice is to establish minimum coefficient of friction requirements for brake linings used in the service brake system of a motor vehicle. Linings that meet these minimum friction requirements may not be suitable for use on all vehicles because of differences in brake design or application.
3. **Test Procedure** - Five complete tests shall be conducted on each brake lining in accordance with the SAE J661.
4. **Brake Lining Evaluation** - Brake linings shall be evaluated for normal and hot friction coefficients in accordance with SAE J866.
5. **Minimum Requirements** - To meet minimum requirements a brake lining shall have:
  - 5.1 A normal friction coefficient over .25 based on the average of five tests.
  - 5.2 A hot friction coefficient over .15 based on the average of five tests.
  - 5.3 A coefficient of friction of .15 or over on each of the five tests at the following points:
    - 5.3.1 Between 200F and 550F, inclusive, on the second fade run.
    - 5.3.2 Between 300F and 200F, inclusive, on the second recovery run.
  - 5.4 Not more than a 20% or .050 variation of coefficient of friction, whichever is greater, below the average value of all five tests at each temperature point specified in paragraph 5.3

(Report of SAE Brake Committee approved January 1968.)

## Appendix B

### MOTORCYCLE AND MOTOR VEHICLE CYCLE ELECTRICAL SYSTEM (Maintenance of Design Voltage) SAE J392

#### SAE Recommended Practice

1. **Purpose** - This SAE Recommended Practice provides minimum illumination voltage values for motorcycle and motor driven cycle electrical systems and accompanying test procedures. (**NOTE:** Where the word "motorcycle" appears in the report, it is understood to include "motor driven cycle.")
2. **Scope** - This recommended practice pertains to both battery-equipped and batteryless motorcycle electrical systems.
3. **Test Apparatus.**
  - 3.1 Voltmeter - 0-20 V maximum full-scale deflection, accuracy +1/2% (two voltmeters required).
  - 3.2 Ammeter - Capable of carrying full system load current. Accuracy +3%FS.
  - 3.3 Means for Measuring Engine RPM - Accuracy +3%.

### 4. Test Procedure

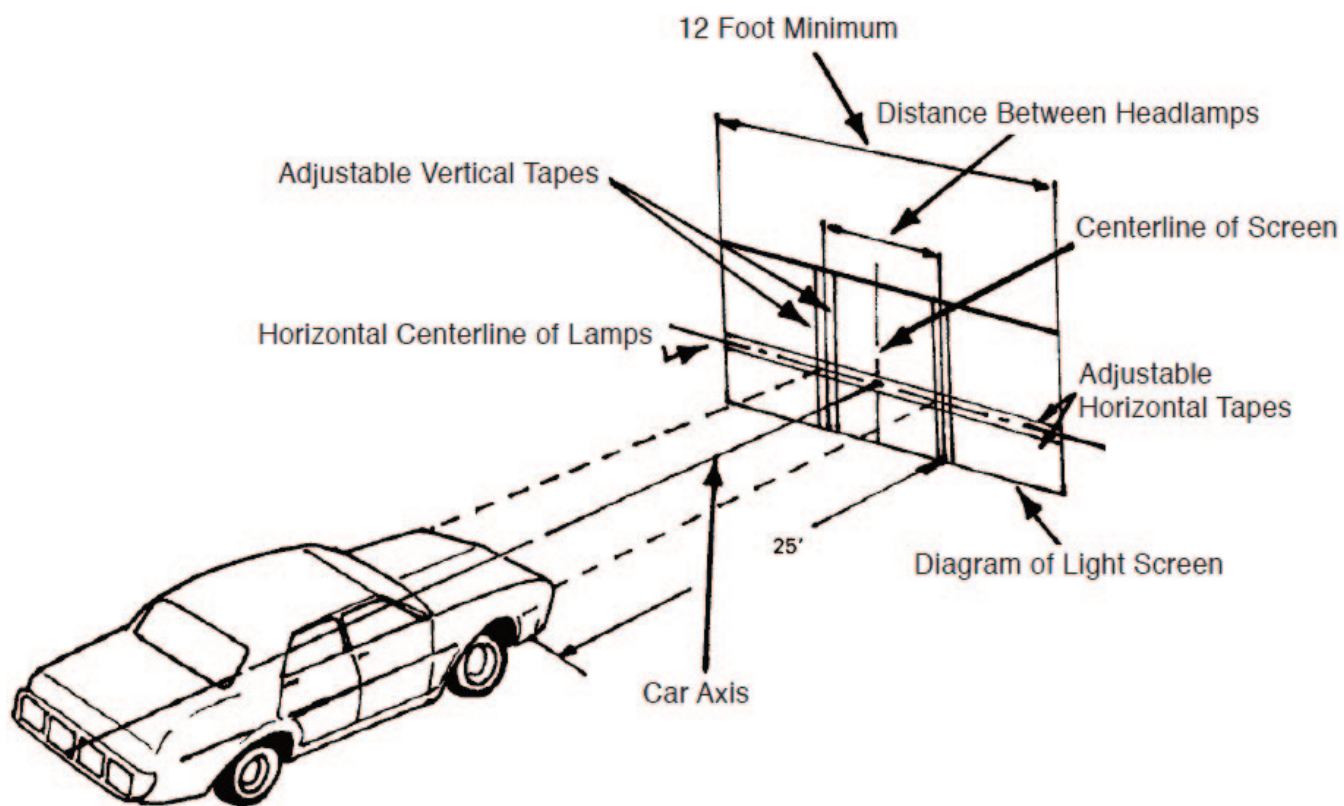
- 4.1 Install fully charged original equipment battery on the motorcycle (if motorcycle is battery equipped).
  - 4.1.1 Battery temperature to be 80+ or -10F.
- 4.2 Connect one voltmeter between the headlamp low beam terminal and the ground; connect the other voltmeter between the tail lamp terminal and the ground.
- 4.3 Connect the ammeter in series with the battery. (**NOTE:** Disregard paragraph 4.3 for batteryless machines.)
- 4.4 Start engine and turn on headlamp(s).
  - 4.4.1 Switch headlamp to the low beam position.
  - 4.4.2 External fan cooling may be applied to the motor cycle engine.
- 4.5 Run the engine at an RPM equivalent to 30 MPH in top gear for 10 minutes.
  - 4.5.1 Record the lowest and highest head-lamp voltage and taillamp voltage observed during the 10 minute period.
- 4.6 Increase speed to manufacturer's suggested maximum RPM.
  - 4.6.1 Record the highest and lowest head-lamp and taillamp voltages observed during a 5-second period.
- 4.7 Run the engine at manufacturer's rated idle speed for 10-minutes.
  - 4.7.1 Record the lowest and highest taillamp voltage observed during the 10-minute period.
  - 4.7.2 Record the lowest and highest headlamp voltage observed during the 10-minute period.
- 4.8 Slowly increase the engine speed until generating equipment cancels the system load, indicated by "0" reading on the ammeter. (**NOTE:** Disregard paragraph 4.8 for batteryless motorcycles.)
  - 4.8.1 Record the engine RPM at ammeter zero point.

### 5. Test Limits

- 5.1 Voltages recorded in paragraphs 4.5.1, 4.6.1 and 4.7.1 shall be between 80% and 120% of the rated headlamp design voltage.
- 5.2 Voltages observed in paragraph 4.7.2 shall be between 40% and 120% of the rated headlamp design voltage.
- 5.3 Engine RPM observed in paragraph 4.8.1 shall be less than the motorcycle equivalent speed at 30 MPH in top gear operation.

(Report of Motorcycle Committee and Lighting Committee approved December 1969. Editorial change November 1971.)

CHART 1  
Headlight Aiming Screen  
Distance and Marking Identification

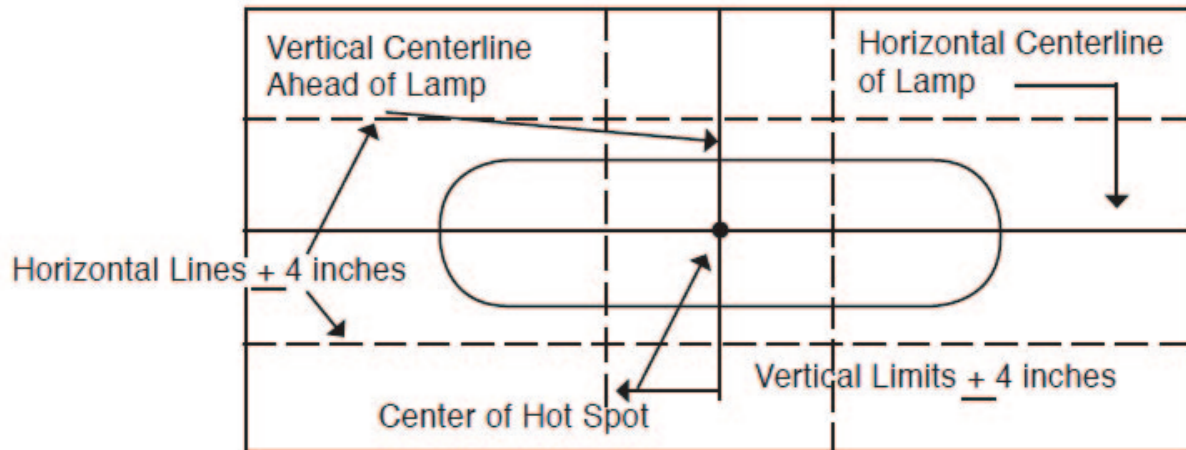


**VISUAL HEADLAMP AIM, ADJUSTMENT AND INSPECTION**



### CHART 2

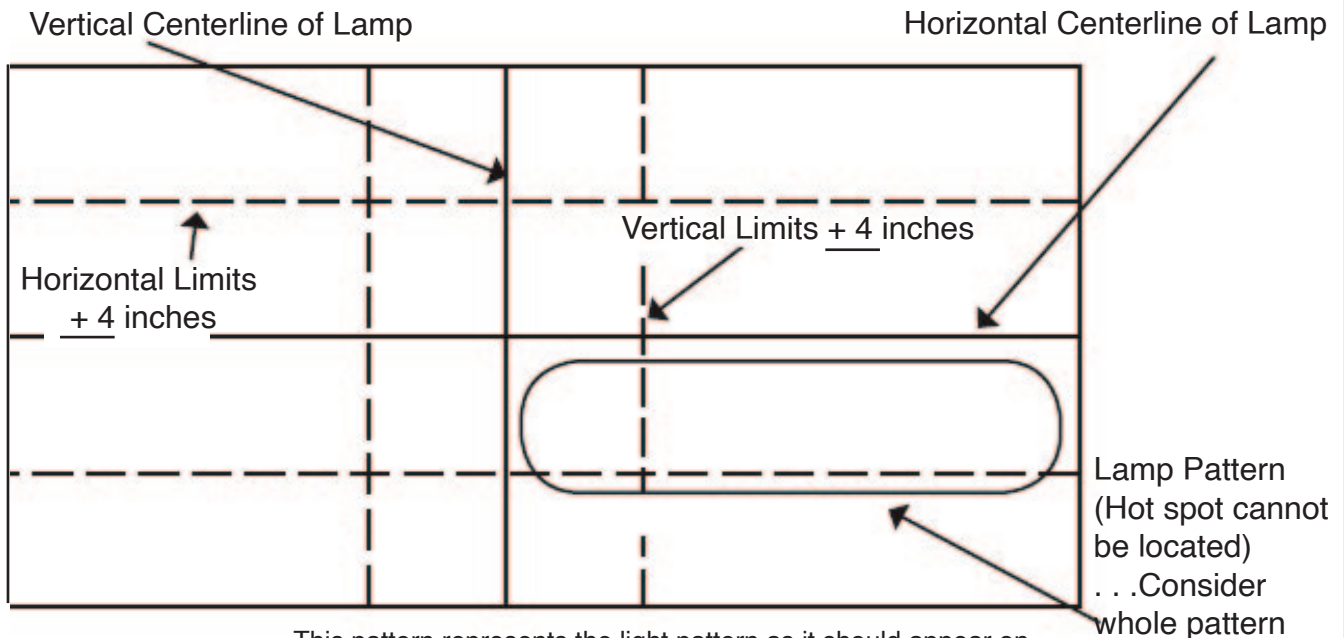
#### High Beam Inspection Limits



This pattern represents the light pattern as it should appear on the view screen of approved photo-electric aimers.

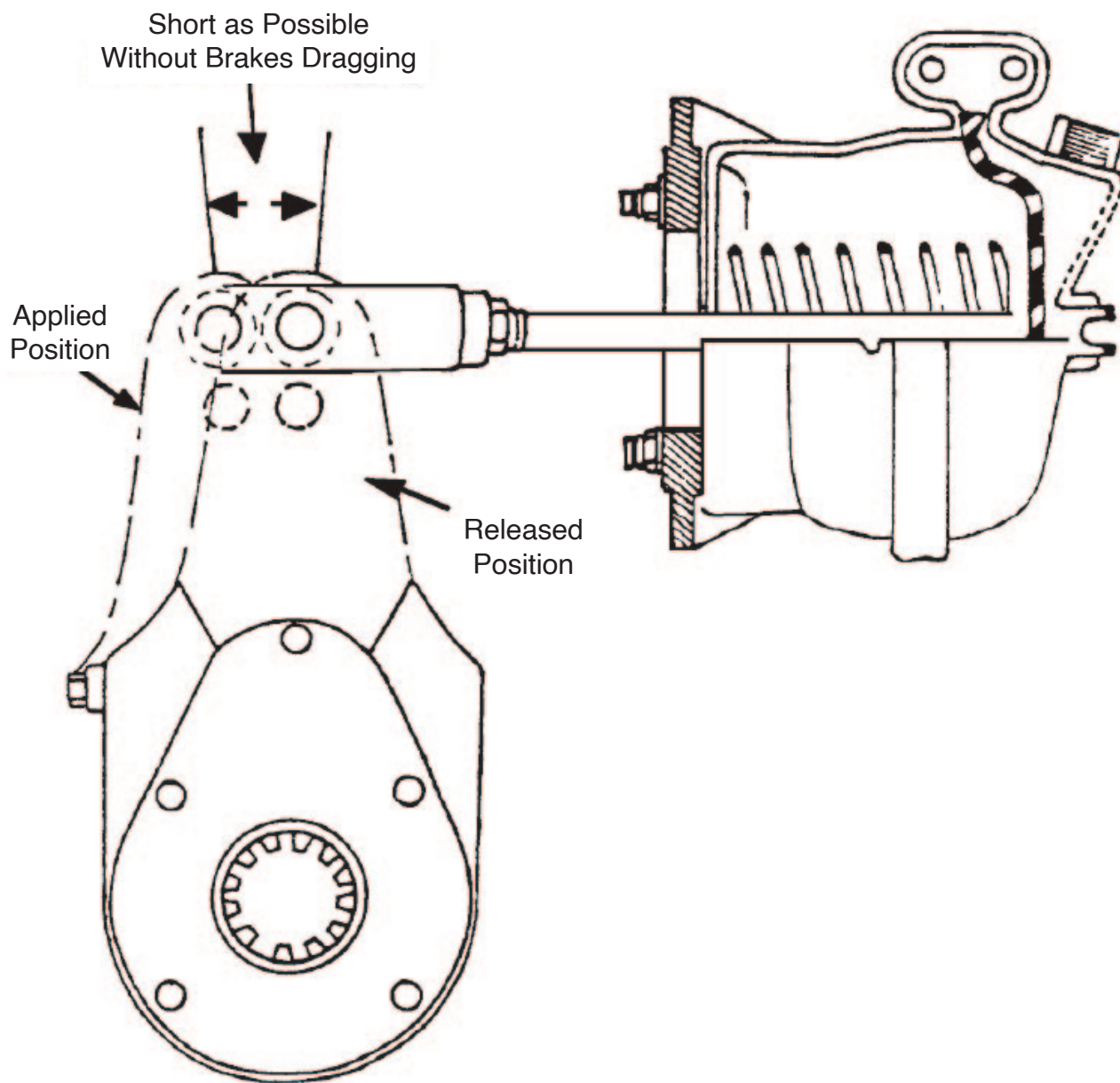
### CHART 3

#### Low Beam Inspection Limits



This pattern represents the light pattern as it should appear on the view screen of approved photo-electric aimers.

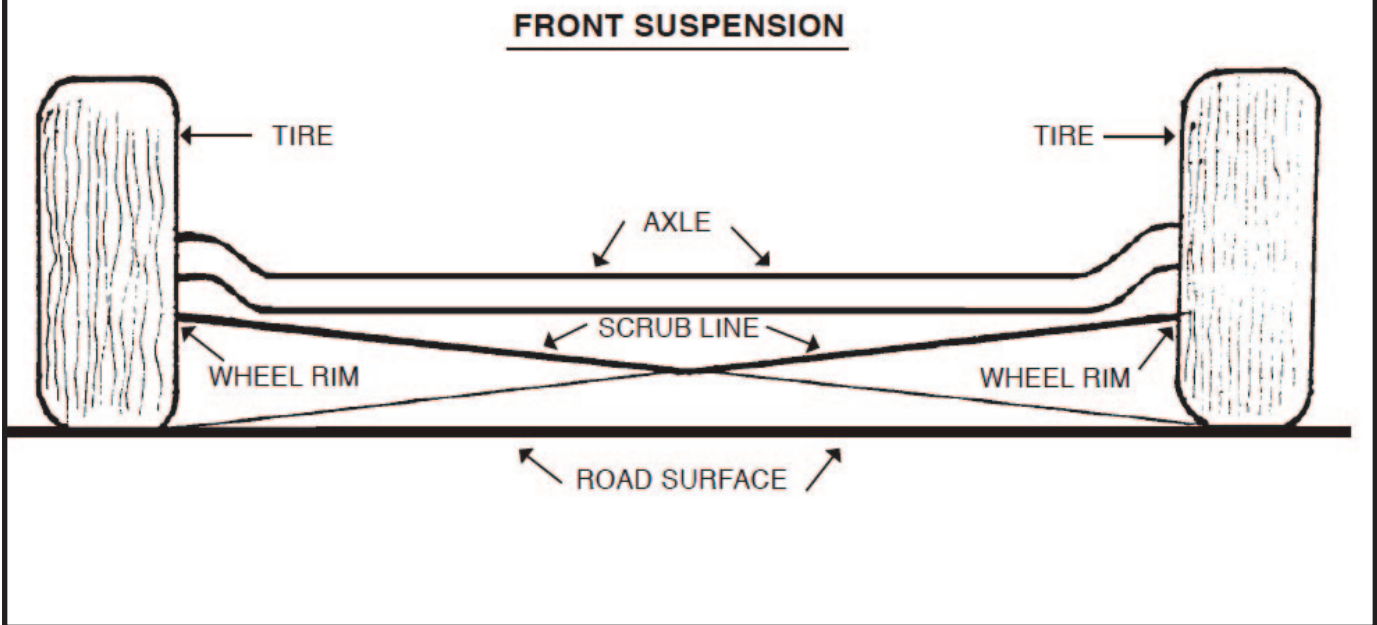
CHART 4  
Brake Chamber Push Rod Travel (Typical)



## CHART 5 Scrub Line

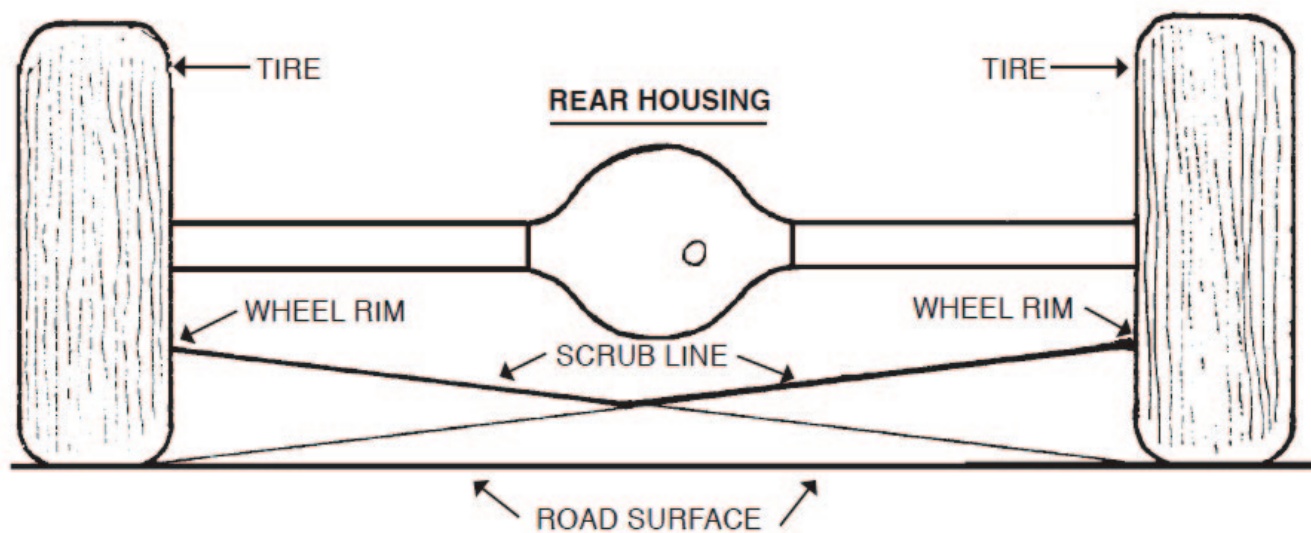
(STREET RODS, SPECIALLY CONSTRUCTED AND RECONSTRUCTED VEHICLES)

A scrub line is an imaginary surface created if lines were drawn from bottom of wheel rim on one side to bottom of tire on other side. When lines are drawn from both sides an "X" under the vehicle suspension is created. No suspension or chassis component shall be below top portion of this imaginary "X".

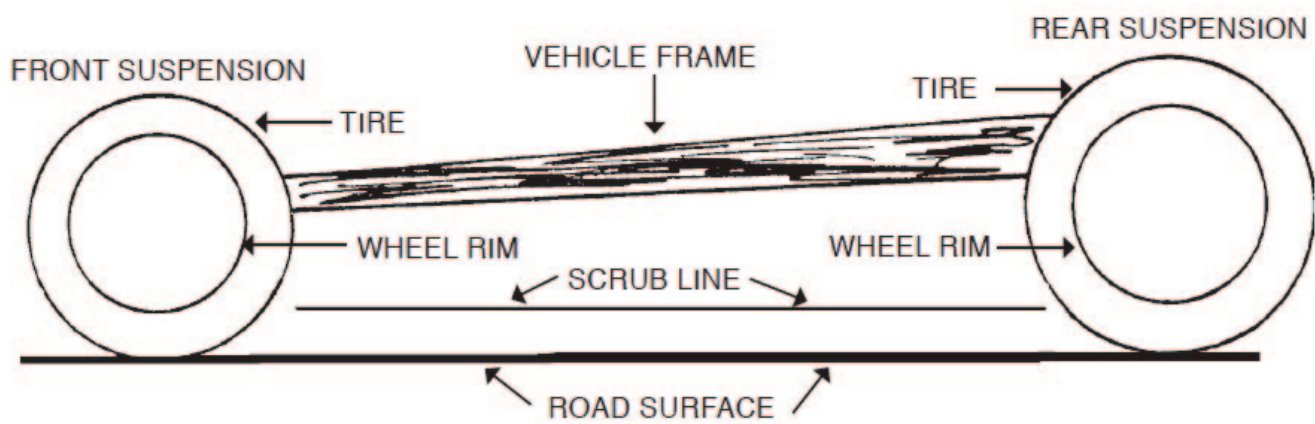


## CHART 5 (Continued)

## DIAGRAM OF THE REAR SUSPENSION, AND HOW TO CHECK SCRUB LINE



## (SCRUB LINE THAT EXISTS FROM FRONT TO REAR SUSPENSION)



## Brakes

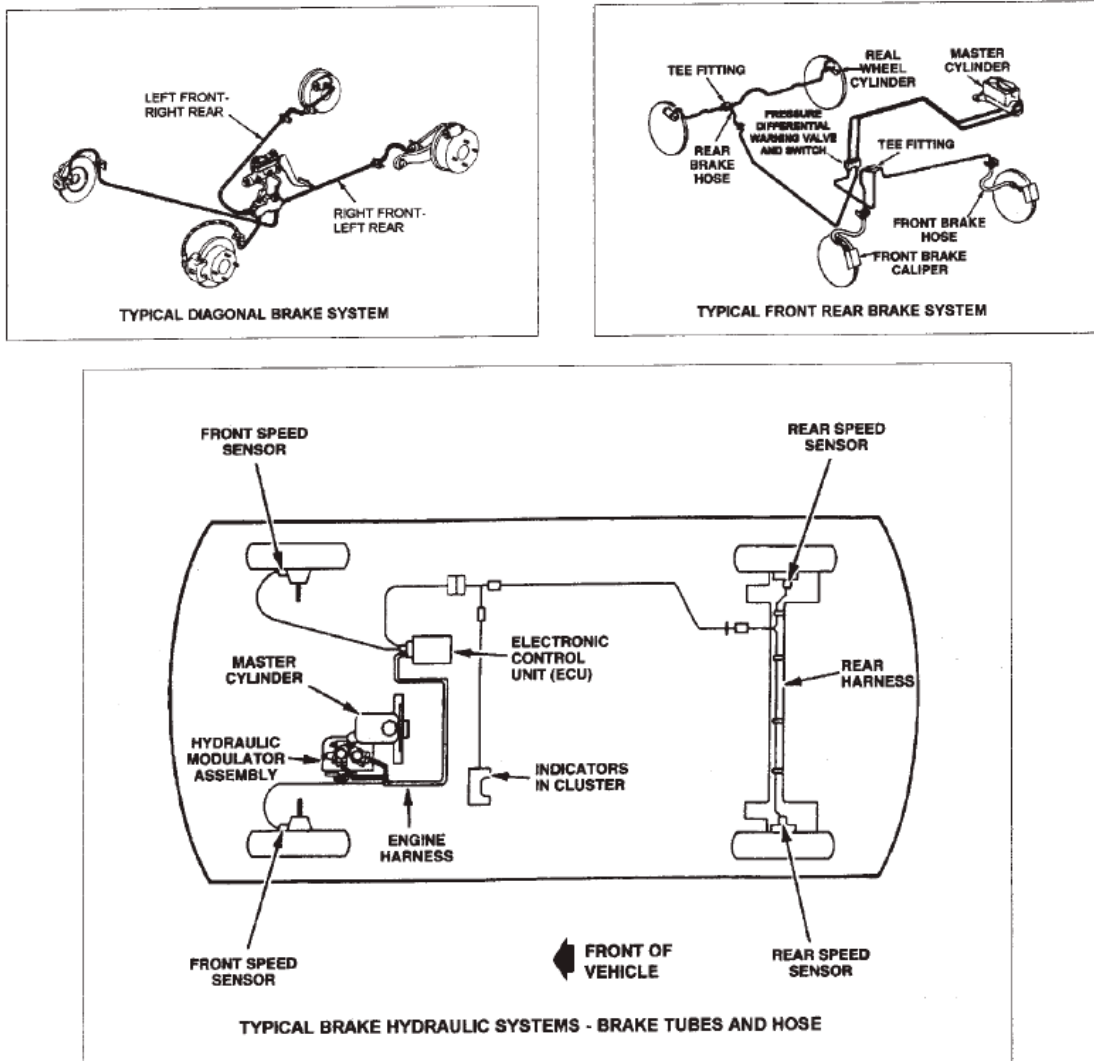
Brake failure ranks as the leading mechanical cause of highway crashes. Brakes require special care to ensure that the braking system is operating properly. The major brake inspection defect items are:

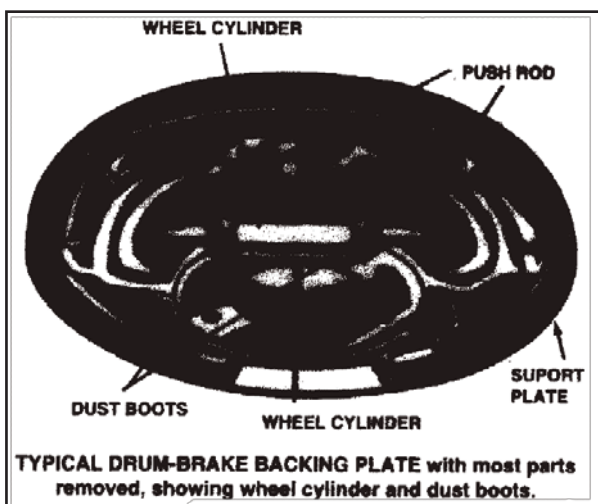
- Hydraulic hoses or tubing
- Wheel cylinders and calipers
- Brake drums or rotors
- Brake linings

The following illustrations will provide the inspector with additional guidance for inspection of these components.

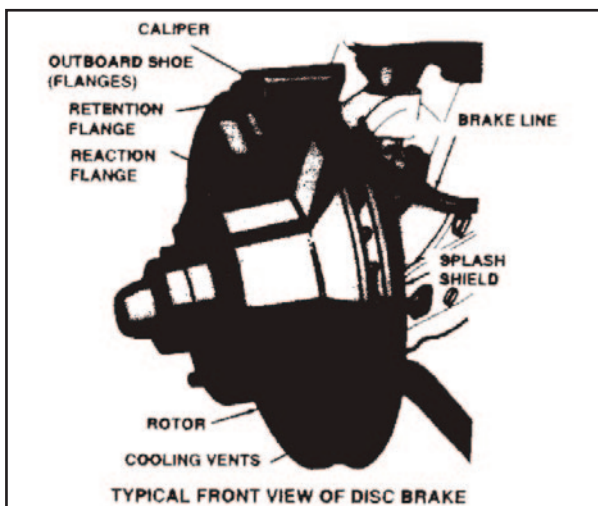
**Figure 1** shows typical brake system configurations including hydraulic brake system tubes and lines and anti-lock brake (ABS) system electronic controls and sensors. The hoses and tube should be visually checked for leaks, cracks, chafing, flattened or restricted sections, or improper retention.

### TYPICAL BRAKE CONFIGURATIONS

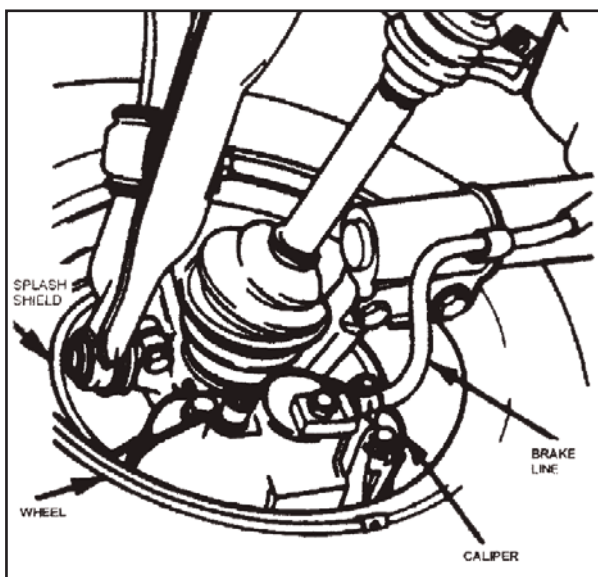




**Figure 2** Shows a typical drum brake. When the drum is removed, the wheel cylinder should be checked for leakage, damaged, loose or missing parts, retention and dust boot condition.

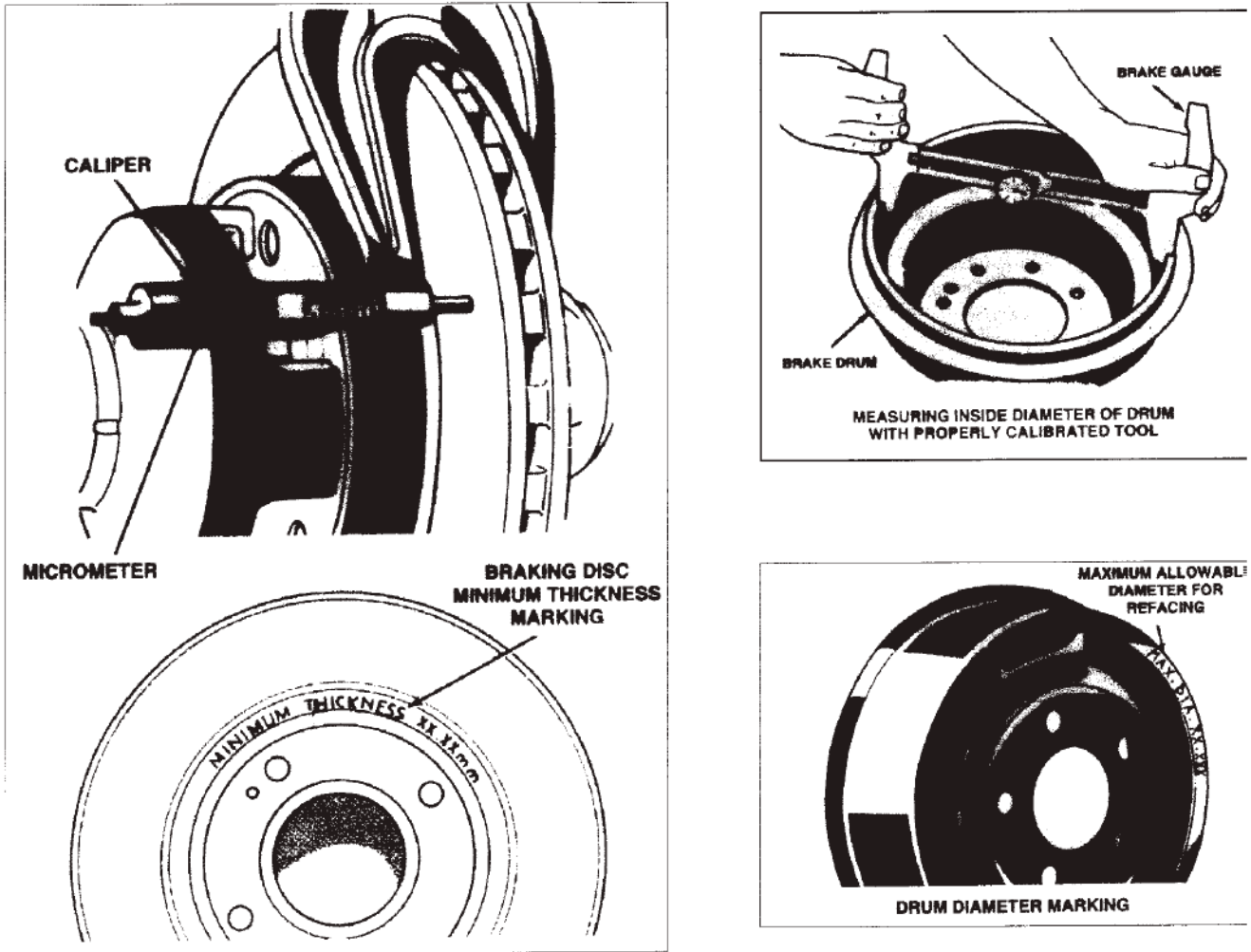


**Figure 3** Shows a typical caliper drum brake. The caliper assembly should be checked for leakage, missing parts and retention.



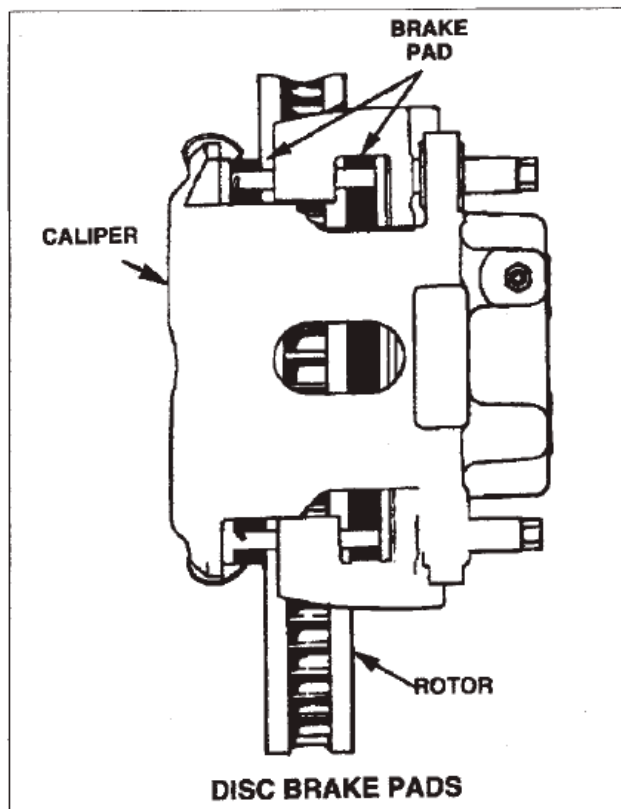
**Figure 4** Illustrates a typical disc brake assembly for a front wheel drive vehicle.

**Figure 5** Illustrates marking and measurements of brake rotors and brake drums. The maximum allowable drum diameters and minimum rotor thickness are cast into the parts. Drums or rotors must not be scored deeper than 0.015 inches.

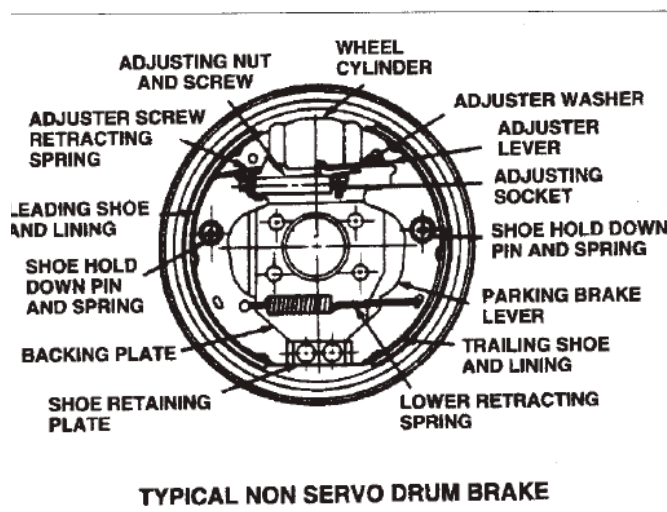
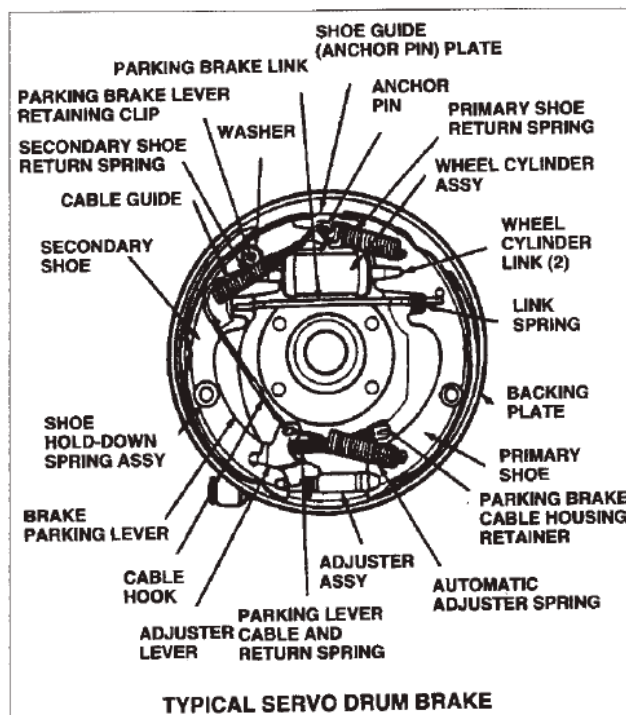


**FIGURE 5**

**Figure 6** illustrates disc brake pads and **Figure 7** illustrates typical drum brakes. Visually inspect the lining to see if it is broken, not firmly attached, or contaminated with oil, grease or any other substances that would affect operation. Use the proper measuring device to measure the linings and pads. Bonded linings must be no less than 2/32 inch and riveted linings must be no less than 1/32 inch above the rivet head at the thinnest point.



**FIGURE 6**



**FIGURE 7**



## Tires

Defective tires cause or contribute to a significant number of crashes. Worn tires reduce ride performance, affect vehicle handling and decrease fuel efficiency. Tire wear is identified by the following characteristics:

- ✓ any two adjacent grooves have less than 2/32 inch of tread
- ✓ tread wear indicators contacting road on any two adjacent grooves
- ✓ exposed ply or cord
- ✓ tire repair using blow-out patch or boot
- ✓ bumps, bulges or separations on surface of tire

Figure 8 illustrates tire wear and how to measure acceptable tire thread depth.

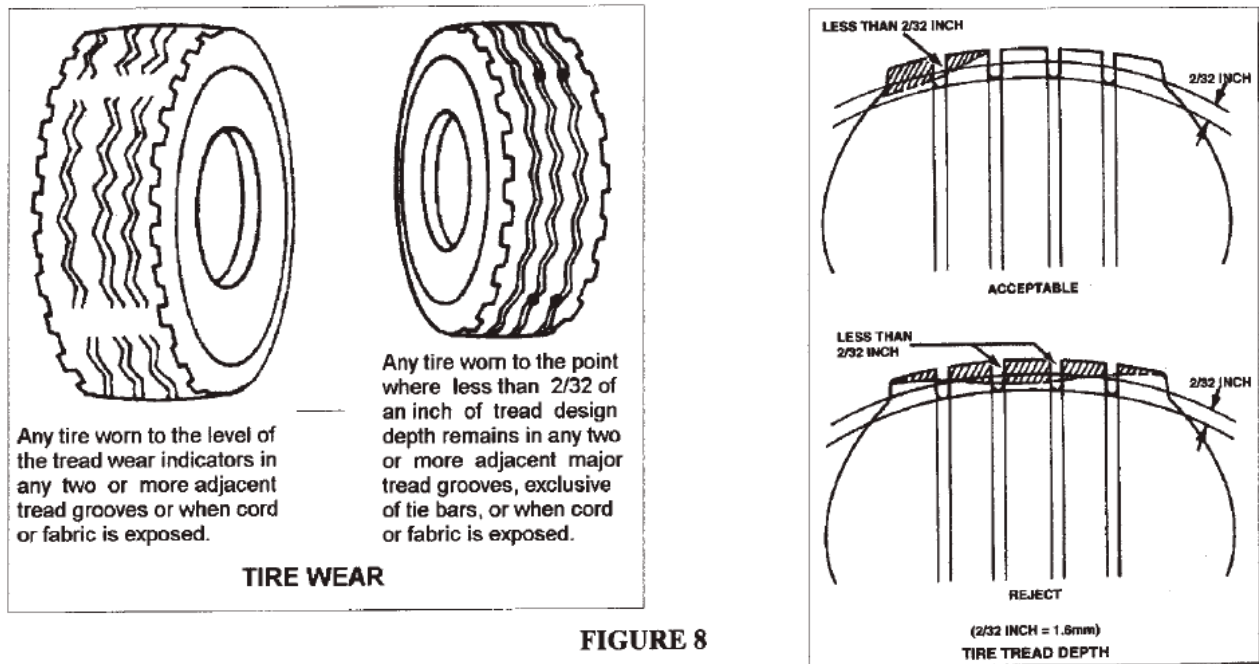


FIGURE 8

CONDITION	RAPID WEAR AT SHOULDERS	RAPID WEAR AT CENTER	WEAR ON ONE SIDE	BALD SPOTS OR SCALLOPED WEAR	FEATHERED EDGES
CAUSE	Underinflation At Full Load (High Pressure on Shoulder Ribs)	Overinflation of Bias Tires at Light Load (Low Pressure on Shoulder Ribs)	Excess Toe or Camber at Full Load (High Pressure on Outer Side)	Brake Lock-up; or Excess Toe in Combination With Loose Steering Joints or Loose Wheel Bearings; or Tire Hop Due to Balance or Runout	Incorrect Toe
CORRECTION	Adjust Pressure to Specifications when tires are cool. Rotate tires.	Adjust Pressure to Specifications when tires are cool. Rotate tires.	First, inspect for incorrect Toe and Reset to Minimum Value in Specification Range. If Toe Setting is Acceptable, Adjust Camber to Specifications	Adjust Camber to Specifications and Pressure According to the Load	Correct Loose Steering and Bearings. Correct Balance and Runout. Correct Spotty Brakes

FIGURE 9

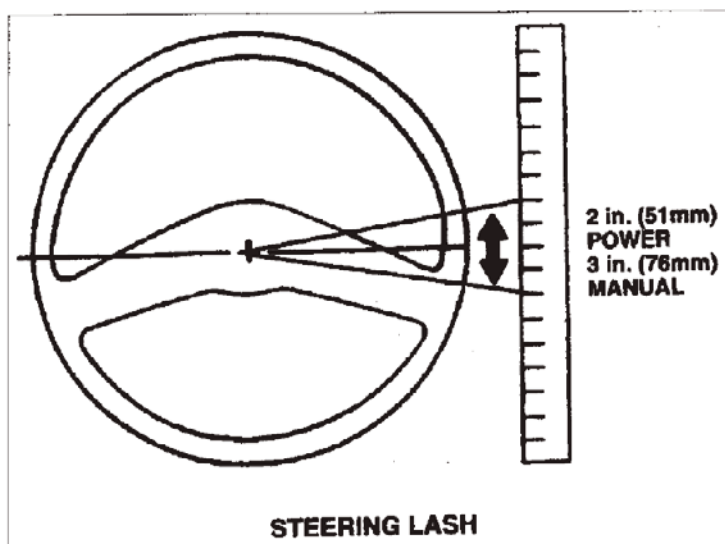
## Steering System

Steering system defects affect the driver's control of the vehicle. The steering column must be checked completely. This includes the following items:

- ✓ Free play of the steering wheel
- ✓ Gear box fastening
- ✓ Energy absorbing column condition
- ✓ Steering wheel size conformance
- ✓ Steering wheel travel to full right and left position without binding
- ✓ Proper alignment of the flexible steering coupler.

Loose steering, especially coupled with excessive tire wear, tight steering in any direction or rubbing noises, indicates a potential defect. **Figure 10** illustrate how to measure free play movement on the steering wheel. The maximum free play permitted varies based upon the diameter of the wheel as follows:

<u>Wheel Diameter</u>	<u>Free Play</u>
16 inches or less	2 inches
18 inches	2 1/4 inches
20 inches	2 1/2 inches
22 inches	2 3/4 inches



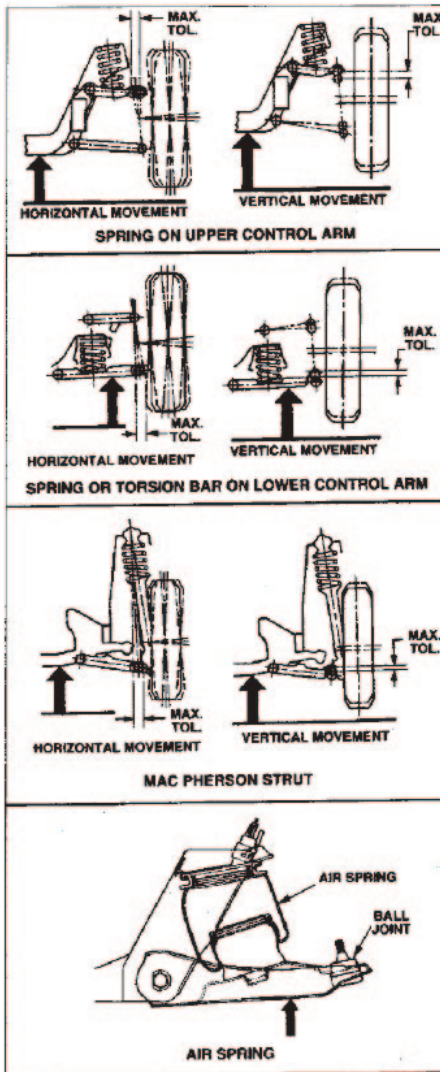
**FIGURE 10**

## Suspension System

Suspension system defects can affect vehicle performance and compromise safety. Defective shocks or struts will cause the vehicle to dive when brakes are applied, to sway on turns, and to bottom out on rough pavement. The following suspension system components are inspected for defects:

- ✓ Ball joint movement
- ✓ Shock absorbers
- ✓ Sway or stabilizer bar
- ✓ Coil spring or main leaf spring
- ✓ Spring attaching parts

Ball joint movement is inspected to determine wear defects. Manufacturer's specifications provide maximum tolerances for both vertical and horizontal movement of the ball joint. The trend among U.S. automobile manufacturers is toward the use of "wear-indicating" ball joints; however many vehicles do not have these useful indicators.



RAISING POSITIONS FOR SUSPENSION SYSTEMS

FIGURE 11

Figure 11 illustrates raising positions for suspension systems to check tolerances. Figure 12 illustrates ball joint wear indicators.

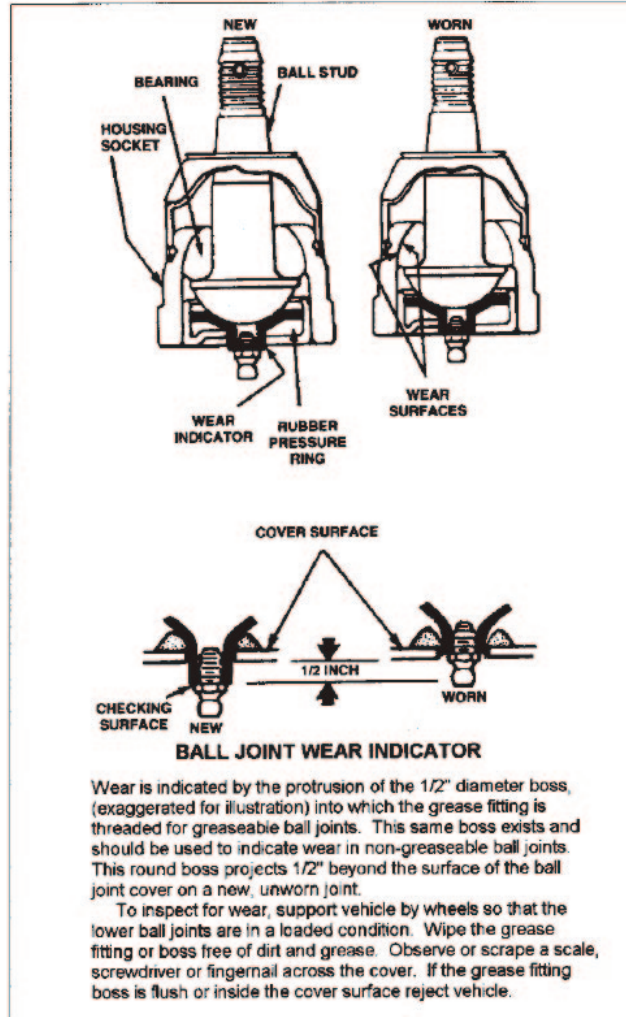


FIGURE 12

Wear is indicated by the protrusion of the 1/2" diameter boss, (exaggerated for illustration) into which the grease fitting is threaded for greaseable ball joints. This same boss exists and should be used to indicate wear in non-greaseable ball joints. This round boss projects 1/2" beyond the surface of the ball joint cover on a new, unworn joint.

To inspect for wear, support vehicle by wheels so that the lower ball joints are in a loaded condition. Wipe the grease fitting or boss free of dirt and grease. Observe or scrape a scale, screwdriver or fingernail across the cover. If the grease fitting boss is flush or inside the cover surface reject vehicle.