



OWNER'S OPERATION AND MAINTENANCE MANUAL

NO. 10722

Revision J

November 2013

VEHICLE FIRE SUPPRESSION SYSTEMS

DRY CHEMICAL MODELS

V13ABC (13 lb. ABC),

V25ABC (25 lb. ABC), VH25ABC (25 lb. ABC Horizontal Mounted),

V50ABC (50 lb. ABC), VS50ABC (50 lb. ABC), VS75 ABC (75lb. ABC)

V13PK (13 lb. Purple K),

V25PK (25 lb. Purple K), VH25PK (25 lb. Purple K Horizontal Mounted),

V50PK (50 lb. Purple K), VS50K (50 lb. Purple K)

LIQUID AGENT MODELS

ICE-1 (1.2 gal.), ICE-2, ICE-H2 (2.4 gal.), ICE-4, ICE-H4, ICE-S4 (4.8 gal),

Manufactured by:

AMEREX CORPORATION

P.O. BOX 81

7595 Gadsden Highway

TRUSSVILLE, AL 35173-0081

Phone: (205) 655-3271

Fax: (205) 655-3279

E-Mail: sales @ amerex-fire.com

Home Page: <http://www.amerex-fire.com>

Printed in U.S.A

CONGRATULATIONS! The installation of an Amerex Vehicle Fire Suppression System on your vehicle is a commendable step toward securing total fire protection for your valuable vehicle. Suppression systems have been shown to reduce equipment loss and equipment downtime, product loss, and most importantly, human life. In addition, installation of a Factory Mutual approved Amerex Vehicle Fire Suppression System can lower the cost of insuring your equipment.

This manual is provided to you, the equipment owner, to explain the basics of the suppression system components and their operation, and how to use the system in case of a fire. It is imperative that all persons expected to operate the equipment on which the suppression system is installed read and understand this manual and become proficient in the suppression system use and operation.

In addition, this manual describes the owner's role in suppression system maintenance and in vehicle or equipment maintenance that will help to ensure proper fire prevention. This manual is not intended to provide detailed information concerning suppression system installation or diagnostics.

The Amerex limited warranty is stated below. To validate this warranty, THE WARRANTY REGISTRATION FORM ON PAGE 12 OF THIS MANUAL MUST BE COMPLETED AND RETURNED TO AMEREX CORPORATION WITHIN 15 DAYS OF SYSTEM INSTALLATION.

Warranty Statement

Warranty and Limitation of Liabilities, Buyers Remedies, and Indemnification

Amerex Corporation (Seller) warrants that Vehicle Fire Suppression System components (Goods) delivered are free from defects in material and workmanship under conditions of normal use for a period of three (3) years from the date of purchase except Small Vehicle Fire Suppression System components and AMGADS gas sensors which are warranted for a period of one (1) year. Non-standard products manufactured by Seller to customer specifications are warranted for a period of one (1) year. Contact Amerex Corporation for warranty statements for other Amerex Corporation products. Seller reserves the right to make any modifications required by production conditions to the information set forth in the Seller's catalogues and advertising literature. Seller shall not be liable or responsible, however, for (A) any defects attributed to normal wear and tear, erosion or corrosion or improper storage, use or maintenance, or (B) defects in any portion or part of the Goods manufactured by others. If (B) above is applicable, Seller will, as an accommodation to Buyer, assign to Buyer any warranties given to it by any such other manufacturers. Any claim by Buyer with reference to the Goods for any cause shall be deemed waived by Buyer unless submitted to Seller in writing within ten (10) days from the date Buyer discovered, or should have discovered, any claimed breach. Buyer shall give Seller an opportunity to investigate.

Provided that Seller is furnished prompt notice by Buyer of any defect and an opportunity to inspect the alleged defect as provided herein, Seller shall, at its option and in its sole discretion either: (i) repair the defective or non-conforming Goods, (ii) replace the nonconforming Goods, or part thereof, which are sent to Seller by Buyer within sixty days after receipt of the Goods at Buyer's plant or storage facilities, or (iii) if Seller is unable or chooses not to repair or replace, return the purchase price that has been paid and cancel any obligation to pay unpaid portions of the purchase price of non-conforming Goods. In no event shall any obligation to pay or refund exceed the purchase price actually paid. This warranty does not cover defects resulting from modification, alteration, misuse, exposure to corrosive conditions or improper installation or maintenance. Repair and/or replacement as provided above shall be at Seller's plant and shipped F.O.B. Plant unless otherwise agreed to by Seller. Transportation charges for the return of the Goods or part thereof to Seller shall be prepaid by Buyer, unless otherwise agreed to in writing by Seller. Seller shall, in no event, be responsible for any labor, removal or installation charges that may result from the above-described repair and/or replacement of any Goods. The foregoing warranty does not cover failure of any part or parts manufactured by others, the failure of any part or parts from external forces, including but not limited to earthquake, installation, vandalism, vehicular or other impact, application of excessive torque to the operating mechanism or frost heave. The exclusive remedy of Buyer and the sole liability of Seller, for any loss, damage, injury or expense of any kind arising from the manufacture, delivery, sale, installation, use or shipment of the Goods and whether based on contract, warranty, tort or any other basis of recovery whatsoever, shall be, at the election of Seller, the remedies described above. The foregoing is intended as a complete allocation of the risks between the parties and Buyer understands that it will not be able to recover consequential damages even though it may suffer such damages in substantial amounts. Because this Agreement and the price paid reflect such allocation, this limitation will not have failed of its essential purpose even if it operates to bar recovery for such consequential damages.

THE FOREGOING WARRANTY IS EXCLUSIVE AND IN LIEU OF ALL OTHER WARRANTIES WHETHER EXPRESS OR IMPLIED BY LAW. THERE IS NO IMPLIED WARRANTY OF MERCHANTABILITY OR FITNESS FOR A PARTICULAR PURPOSE. IN NO EVENT, WHETHER AS A RESULT OF BREACH OF CONTRACT, WARRANTY, TORT (INCLUDING NEGLIGENCE) OR STRICT LIABILITY, SHALL SELLER BE LIABLE FOR ANY PUNITIVE, SPECIAL,

INCIDENTAL OR CONSEQUENTIAL DAMAGES INCLUDING, BUT NOT LIMITED TO, LOSS OF PROFIT, LOSS OF USE OF THE GOODS OR OTHER PROPERTY EQUIPMENT, DAMAGE TO OTHER PROPERTY, COST OF CAPITAL, COST OF SUBSTITUTE GOODS, DOWNTIME, OR THE CLAIMS OF BUYER'S CUSTOMERS FOR ANY OF THE AFORESAID DAMAGES. SELLER SHALL NOT BE LIABLE FOR AND BUYER AGREES TO DEFEND AND INDEMNIFY SELLER AGAINST ALL CLAIMS OR LOSSES (INCLUDING ATTORNEYS' FEES), INCLUDING PERSONAL INJURY, PROPERTY DAMAGE OR OTHER LIABILITY, RESULTING IN WHOLE OR IN PART FROM (1) THE NEGLIGENCE OF BUYER OR ITS CUSTOMERS; (2) BUYER'S OR ITS CUSTOMER'S MISUSE, damage, alteration or modification of Seller's Goods; (3) Buyer's OR ITS CUSTOMER'S use of the Goods in any product or system designed, manufactured or sold by Buyer OR ITS CUSTOMERS; OR (4) ANY BREACH OF THIS AGREEMENT; provided, however, that Buyer shall have no obligation to indemnify Seller for claims or losses that arise solely from the negligence or misconduct of Seller.

In any contract by Buyer for resale of the Goods, Buyer shall effectively disclaim, as against Seller, any implied warranty of merchantability and all liability for property damage or personal injury resulting from the handling, possession or use of the Goods, and shall exclude, as against Seller, any liability for special or consequential damages. To obtain performance of the obligation of this warranty, written notice should be made within 30 days after discovery of the defect and before expiration of the warranty to Amerex Corp., P. O. Box 81, Trussville, AL 35173-0081.

WHAT IS PROTECTED BY A VEHICLE FIRE SUPPRESSION SYSTEM? Vehicles are susceptible to fires because they contain fuel sources (diesel, gasoline, hydraulic oil, wood chips, coal dust, debris, insulation, etc.) and ignition sources (manifolds, turbochargers, battery boxes, brakes, wiring harness, electric motors, etc.) co-existing in high pressure, high vibration, long operating shift environments. Areas likely to produce fire are called "Hazard Areas" and have been identified by your Amerex systems installer. It is these hazard areas that your Amerex Vehicle Fire Suppression System was designed and installed to protect.

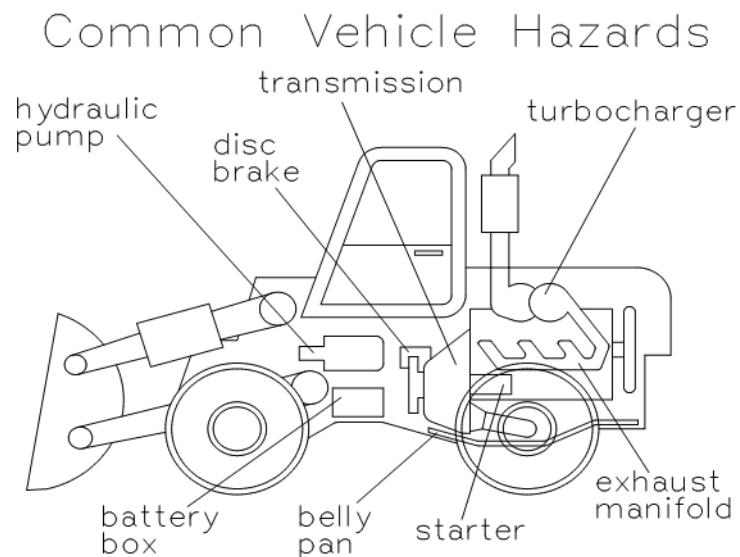

HOW THE SYSTEM WORKS - TYPICAL FIRE SCENARIOS

The following is a typical scenario for an installation utilizing automatic fire detection and electrical system actuation. This example shows the method of automatically activating the system through the use of spot heat detectors or linear heat detection cable assemblies.

(1) A fire starts in a protected area.

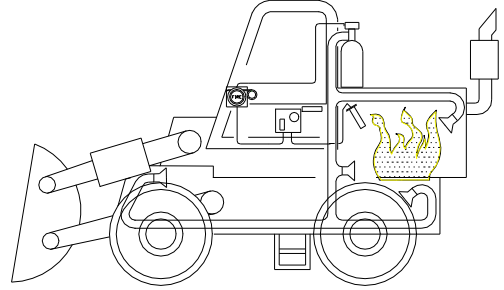

(2) Heat and flames cause the temperature to rise to the set point of the spot heat detectors or linear detection cable. Upon reaching temperature, the contacts of the spot heat detectors close or the insulation of the linear heat detection cable melts causing a completed circuit.

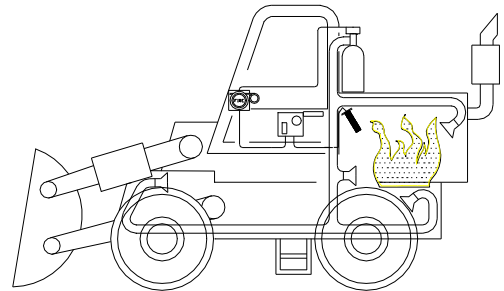

(3) The completed circuit energizes the linear actuator on the agent cylinder valve. The linear actuator opens the agent cylinder valve allowing pressurized fire suppression agent to flow into the distribution hoses leading to the discharge nozzles. The pressure of the entering fire suppression agent causes the protective dust caps located on the nozzles to be blown off.

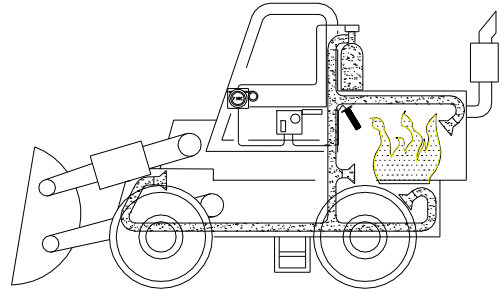

(4) Fire suppression agent discharges through fixed nozzles into protected areas, to suppress the fire. Simultaneously, the relay switches the auxiliary contacts and, for example, closes a fuel shutoff solenoid valve stopping the engine.

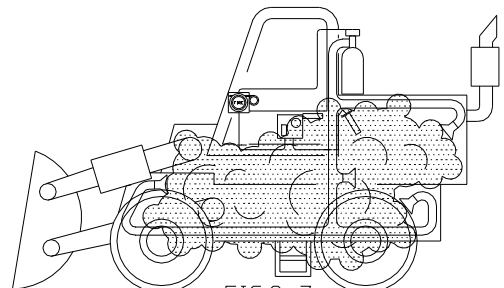
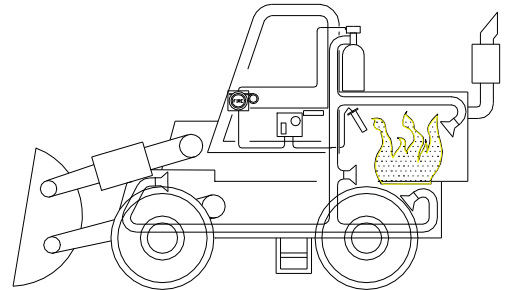

FIG.2-7

The following is a typical scenario for an installation utilizing electrical system actuation. This example shows the method of manually activating the electrically actuated fire suppression system.

(1) A fire starts in a protected area.



(2) Equipment operator (1) pulls the ring pin & (2) presses the red "FIRE" button on the manual actuation switch, which energizes the linear actuator on the agent cylinder valve.

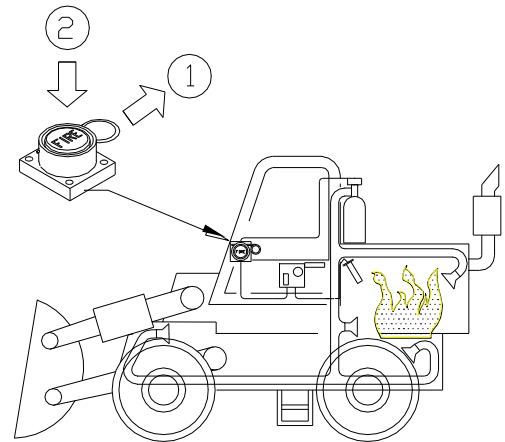

(3) The linear actuator opens the agent cylinder valve allowing pressurized fire suppression agent to flow into the distribution hoses leading to the discharge nozzles. The pressure of the entering fire suppression agent causes the protective dust caps located on the nozzles to be blown off.

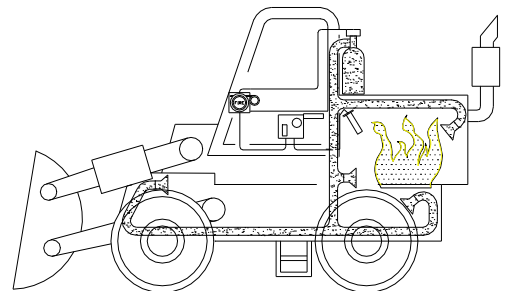

(4) Fire suppression agent discharges through fixed nozzles into the protected areas, suppressing the fire.

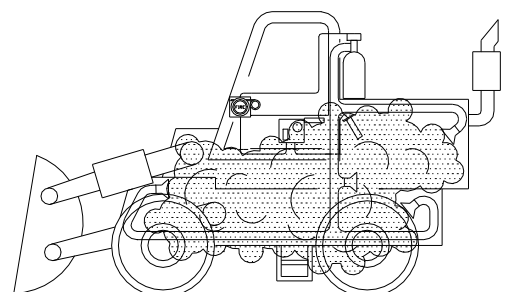
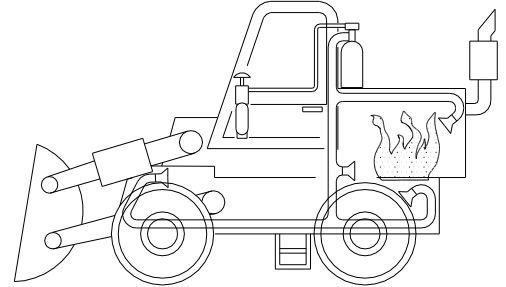

FIG.2-8

The following is a typical fire scenario for an installation utilizing manual only fire detection and remote pneumatic fire suppression system actuation.

(1) A fire starts in a protected area.



(2) Equipment operator (1) pulls the ring pin & (2) strikes the palm button on the manual actuator, releasing nitrogen gas into the actuation lines leading to the pneumatic control head on top of the agent cylinder valve.

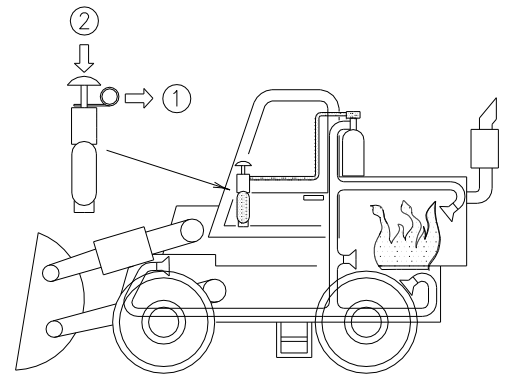

(3) The nitrogen pressure entering the pneumatic control head opens the agent cylinder valve allowing pressurized fire suppression agent to flow into the distribution hoses leading to the discharge nozzles. The pressure of the entering fire suppression agent causes the protective dust caps located on the nozzles to be blown off.

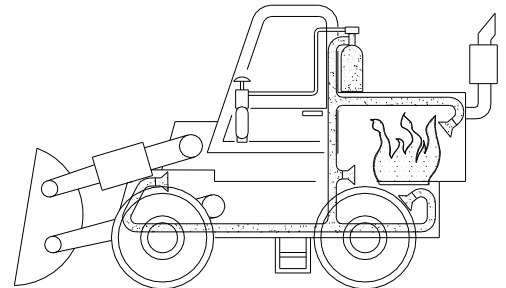

(4) Fire suppression agent discharges through fixed nozzles into protected areas, suppressing the fire.

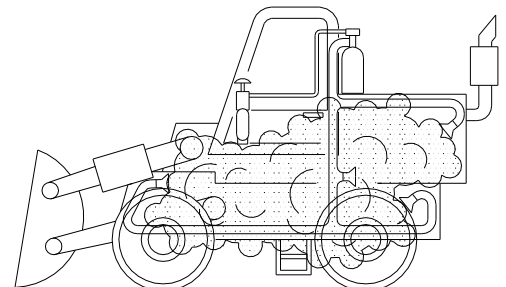
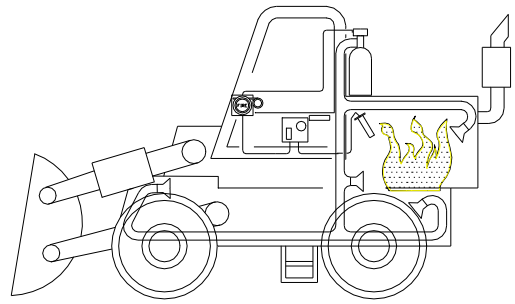

FIG.2-6

The following is a typical scenario for an installation utilizing manual/electrical system actuation. This example shows the method of manually activating the electrically actuated fire suppression system.

(1) A fire starts in a protected area.



(2) Equipment operator (1) pulls the ring pin & (2) presses the red "FIRE" button on the manual actuation switch causing a completed circuit.

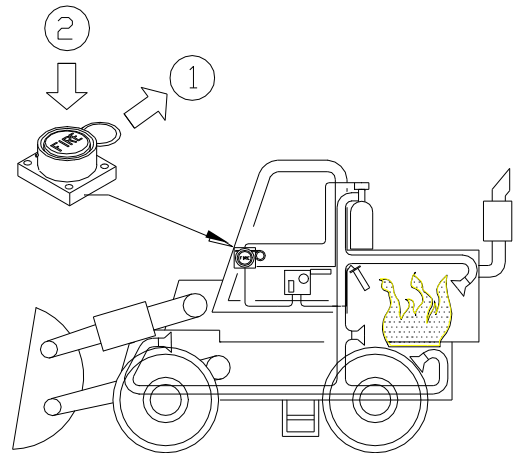

(3) The completed circuit energizes the linear actuator on the electric/nitrogen actuator. The electric/nitrogen actuator opens the nitrogen cylinder which pressurizes the pneumatic control on the agent cylinder valve allowing pressurized fire suppression agent to flow into the distribution hoses leading to the discharge nozzles.

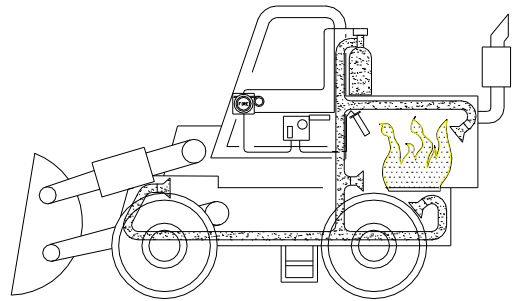

(4) Fire suppression agent discharges through fixed nozzles into the protected areas, suppressing the fire.

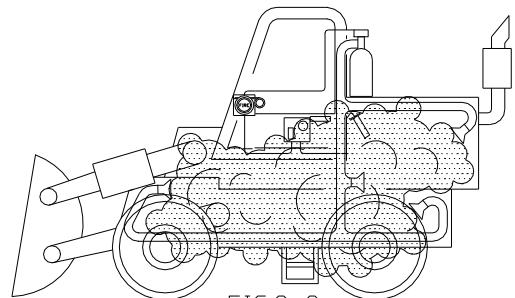

FIG.2-8

IN CASE OF FIRE:

To Manually Operate the Suppression System:

TURN OFF THE EQUIPMENT. BRING TO A SAFE & CONTROLLED STOP AND SET BRAKES.

ACTIVATE THE FIRE SUPPRESSION SYSTEM (1) BY PULLING THE RING SAFETY PIN AND STRIKING DOWN HARD ON THE PALM BUTTON, OR (2) BY PULLING THE RING SAFETY PIN AND PRESSING THE RED "FIRE" BUTTON DEPENDING ON THE METHOD OF ACTUATION USED IN YOUR SYSTEM CONFIGURATION.

GET AWAY FROM THE EQUIPMENT. TAKE A HAND PORTABLE FIRE EXTINGUISHER ALONG IF POSSIBLE OR OBTAIN ONE FROM ANOTHER LOCATION.

STAND BY WITH PORTABLE FIRE EXTINGUISHER AND WATCH FOR SIGNS OF REIGNITION.

Reasons Behind The Actions:

A running piece of equipment can continue to pump fuel or hydraulic fluid, adding to the fire. Its cooling fan creates wind currents that can reduce the effectiveness of the suppression system discharge. Its electrical system or other hot spots can continue to reignite the fire. Powering the vehicle down reduces the possibility of reignition.

By getting away from the equipment, the operator, as well as others, are protected from possible explosions or heat injuries.

Because residual heat could cause a reignition of the fire, or because the fire may be deep seated (vehicle fire suppression systems are not intended to extinguish deep seated fires) it is important to stand by with a portable fire extinguisher. Maintain the standby until all possibility of reflash is eliminated and all residual heat has dissipated.

What To Expect:

Discharge of the fire suppression system is noisy and can produce a large cloud of extinguishing chemical. Breathing the chemical is unpleasant and may cause some irritation.

If automatic activation of the suppression system occurs on a vehicle equipped with automatic vehicle shutdown, be prepared to utilize the shutdown delay feature as required to bring the vehicle to a safe stop.

WARNING: VEHICLES EQUIPPED WITH THE OPTIONAL VEHICLE ENGINE SHUT-DOWN MAY EXPERIENCE LOSS OF POWER AND/OR STEERING AND BRAKING. ONCE A FIRE CONDITION IS DETECTED, THE DELAY BUTTON ON THE PANEL MAY BE DEPRESSED REPEATEDLY AS NEEDED TO DELAY ENGINE SHUTDOWN AND ALLOW SUFFICIENT TIME TO BRING THE VEHICLE TO A SAFE AND CONTROLLED STOP. ALL POTENTIAL OPERATORS MUST BE THOROUGHLY INSTRUCTED IN THE USE OF THIS FEATURE.

CAUTION: Vision may be temporarily obstructed following system discharge. Over the road vehicles equipped with dry chemical fire suppression systems should be evaluated. Visual warnings such as "CAUTION: VEHICLE EQUIPPED WITH AUTOMATIC FIRE SUPPRESSION SYSTEM. KEEP BACK 200 FEET" may be required on rear of vehicle.

After The Fire Has Been Extinguished:

DO NOT restart the equipment until it has been serviced and cleaned. Use a water stream, compressed air or pressure washer to remove chemical residue.

DO NOT return the equipment to service until the suppression system has been serviced and recharged by Amerex Factory Certified Personnel, and until the source of the fire has been located and neutralized.

ELECTRICAL CONTROLS:

All installations of Amerex Vehicle Fire Suppression Systems equipped with automatic fire detection and system actuation will include an electronic display panel. The panel serves to actuate the suppression system and to indicate the suppression system status. It is imperative that all equipment operators understand the meaning of panel displays and know what actions to take as a result of the indications given. The suppression system panel should be checked frequently by the operator during routine equipment operations. The panel LED indicators are explained in the following tables and illustrations. The panels are shown in detail on the following page.

Notes:

a) **Alarm Silence Feature:** The alarm may be silenced only after a fault or fire condition occurs. To silence the alarm, depress the button labeled "PUSH TO SILENCE." When the alarm silences, an amber "silence engaged" LED will illuminate.

b) **Test Feature:** The Modular Circuit Monitor III P/N's 17308 & 17309 and Modular Control Panel P/N 17310 and 17311) and the SafetyNet Operator Display (P/N 16389) are equipped with a test feature which allows verification of proper function of the audible alarm, fire warning, and fire relay features. To use the test features depress and hold the button labeled "Push to Test". The panel will cycle exactly as in a true fire scenario except that the system will not discharge. Release of the test button returns the control panel to normal operations. In addition to the LED indicators the SafetyNet Display Panel also features text message displays of system status and fault conditions on a VFD screen on the panel face. For a complete description, operation and schematics for P/N 17308, 17309, 17310 and 17311 Panels refer to Amerex Manual P/N 19680. For a complete description, operation and schematics for SafetyNet Systems refer to Amerex Manual P/N 16601.

Green LED	Red LED	Audible Alarm	Meaning	Action Required
On	Off	Off	Normal	None
Off or ON	On	On	Fire detected, system dis-charging OR critical fault detected	Bring vehicle to a stop. Evacuate vehicle. Standby with a portable extinguisher. Call Amerex Systems Service personnel. Do not operate the vehicle until the fire suppression system is serviced.
Off	Off	Off	Fault detected	Call Amerex Systems Service personnel. Do not operate the vehicle until the fire suppression system is serviced.

c) **Back-Up Battery:** The Circuit Monitor III P/N's 17308 & 17309, Control Panel III P/N 's 17310 & 17311 and SafetyNet Systems are equipped with a backup battery which controls the fire suppression functions in the event of main power failure. If main power fails, a red "Service System" LED is illuminated and the green "System OK" LED turns off. The back-up battery will sustain system function for a maximum of 24 hours after vehicle battery power interruption. The back-up battery is automatically recharged after approximately 8 hours when vehicle battery power is restored. The back-up battery must be replaced after two years of service. In the SafetyNet System the backup battery is located in the P/N 16390 Driver Panel. (See Amerex Manual P/N 16601 for complete SafetyNet information).

d) **Fire Relay Delay Feature:** The Modular Control Panel III's P/N's 17310 and 17311 and SafetyNet Systems are equipped with auxiliary relay contacts which, on customer request, may be used to power down the vehicle or equipment. An internal timer is used to control the interval between illumination of the red "FIRE" LED and the actual powering down of the vehicle. This interval is preset by the Amerex systems installer to the customer's specific requirements. The fire relay delay feature can allow the equipment operator to temporarily avoid engine power down thereby sustaining power steering and braking so that the vehicle can be brought to a safe and complete stop. To use the fire relay delay feature, depress the button labeled "RELAY RESET". The delay/reset button may be depressed repeatedly as required, or held down indefinitely to allow sufficient time to safely stop the vehicle. Following release of the reset button, powering down of the vehicle resumes from the beginning of the timed interval. To assist the equipment operator in determining when to push the delay button to avoid power down, the amber LED next to the delay button will illuminate just prior to actual powering down of the vehicle. Following power down, this "fire relay timer" LED remains illuminated until the suppression system is serviced.

Detail of Control Panel III (left) and Circuit Monitor III (right) features:



Detail of SafetyNet Operator Display:

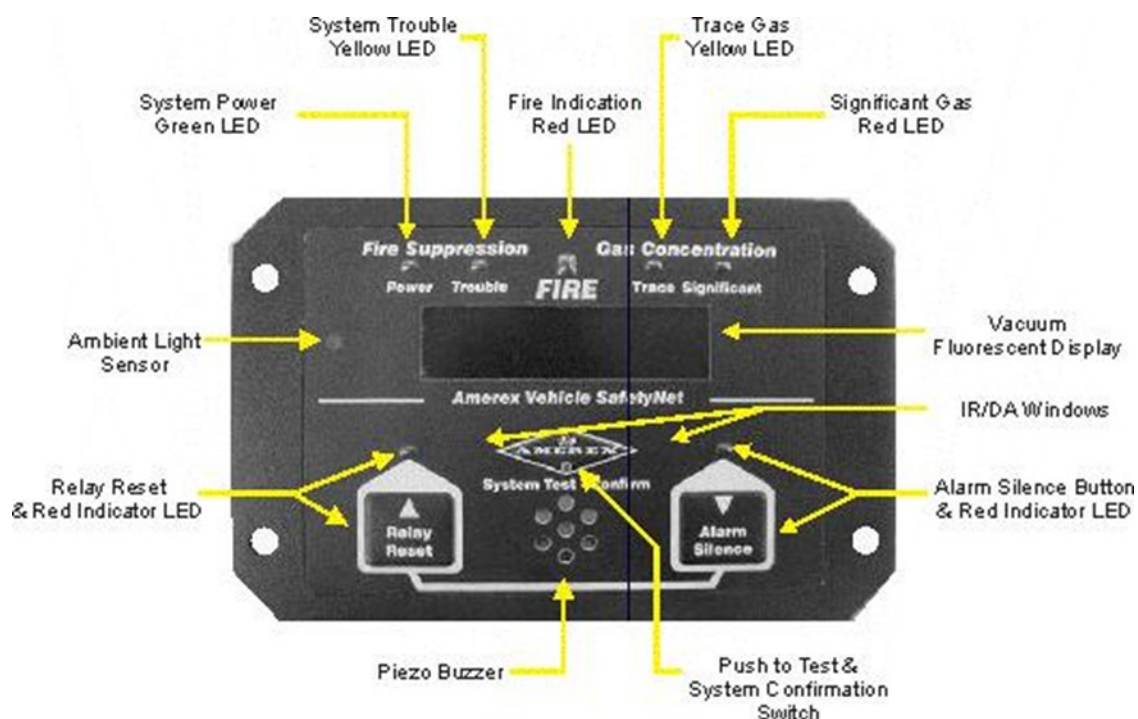

THE OWNER'S ROLE IN PROTECTING THE VEHICLE

Vehicle owners play the primary role in protecting the vehicle by being responsible for FIRE PREVENTION. Vehicle fire prevention includes:

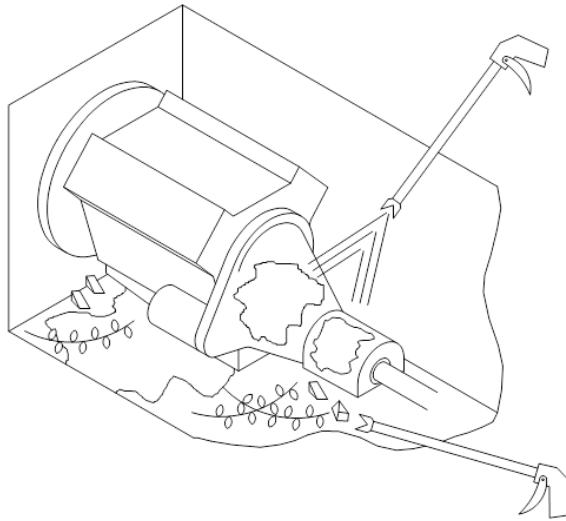

VEHICLE HOUSEKEEPING: Inspect and clean vehicle regularly to remove accumulations of solid combustibles such as dry vegetation, paper, wood or coal dust, and flammable liquids such as grease, fuel and oil. Pay particular attention to all hazard areas including engine area, hydraulic manifolds and belly pan. Use high pressure water or steam spray when required.

VEHICLE MAINTENANCE: Proper vehicle maintenance is essential to successful fire prevention.

Insure complete integrity of all hydraulic fluid and fuel lines. Replace any sections exhibiting signs of abrasion and tighten all connections. Make sure all hoses are properly secured to prevent their contact with high temperature ignition sources such as turbochargers or exhaust manifolds. Insure complete integrity of all electrical leads and connections. Replace any wires or components exhibiting signs of damage and clean and tighten all connections. Insure proper function of all vehicle mechanical systems. Adjust brakes to prevent overheating and confirm proper coolant flow to turbocharger and other components with overheat potential.

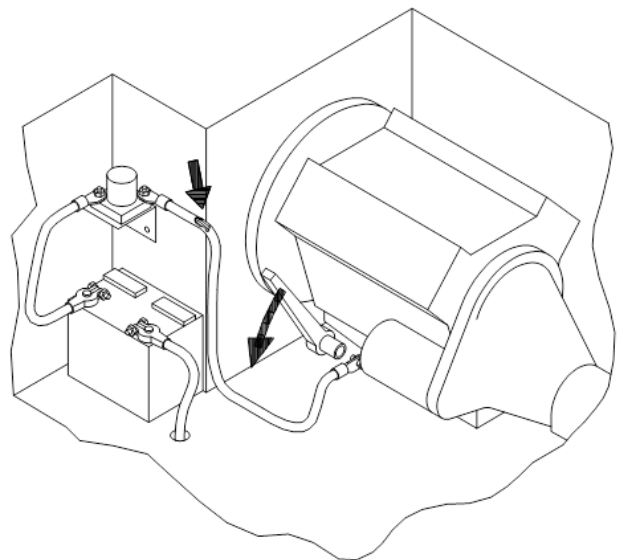
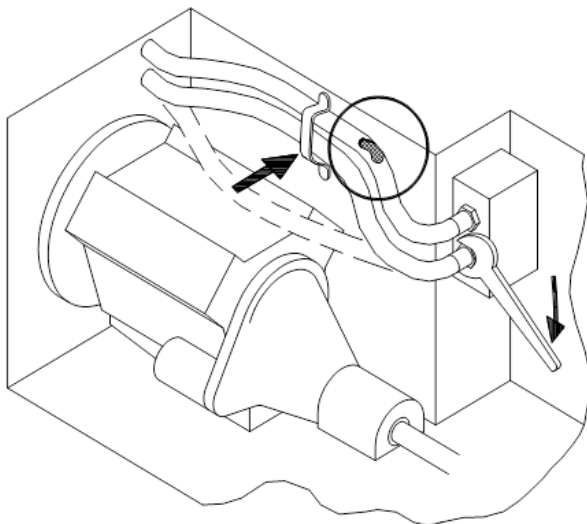

WHAT ELSE CAN OWNERS DO TO PROTECT THE VEHICLE

Vehicle owners also play the primary role in protecting the vehicle by insuring that the fire suppression system is used and maintained properly. This must be accomplished by:

TRAINING OPERATORS: All operators must be thoroughly trained in manual actuation of the suppression system, electrical monitoring or control panel interpretation and fire relay delay operation.

PROVIDING FOR VEHICLE MODIFICATION: Your Amerex Systems certified installer should be notified of **any** modifications to the vehicle so that potential changes in hazard can be identified and protected.

INSURING DESIGN INTEGRITY: Your Amerex Vehicle Suppression System has been expertly designed and installed by personnel certified in these operations. **Never** attempt to modify the suppression system in any way or relocate any components. Enlist the help of your Certified Amerex Systems Installer when modifications or repairs are required.

SCHEDULING REGULAR MAINTENANCE: It is the vehicle owner's responsibility to schedule monthly inspections, and semi-annual or 1000 hour maintenance. Amerex Corporation warrants only those systems that are properly maintained. Inspections and maintenance will often reveal the need for 12 year hydrostatic retest or 6 year teardown of the Agent Cylinder as required by the National Fire Protection Association (NFPA).

PERFORMING QUICK CHECKS: Fire suppression systems can become damaged in between routine inspections. An added measure of safety can be achieved through vehicle owner/operator self-inspections:

On a daily basis: Check the pressure gauges on all agent cylinders and N2 cylinders if so equipped, for proper operating pressure. Proper pressurization is indicated when the pointer is in the "green pie" zone. On automatic systems, verify that the green "SYSTEM OK" LED on the Circuit Monitor III, Control Panel III or SafetyNet Display is illuminated.

On a weekly basis: Check all system components for corrosion or damage, and to insure that all mountings are secure. Check all 1/2 and 3/4 inch chemical delivery and all 1/4 inch system actuation hoses for cuts, abrasion or kinks, and to insure that all joints are tight. Check the suppression system electrical network for cuts or abrasion on wires or dents or damage to spot heat detectors, and to insure that all connections are tight. Carefully clean spot heat detectors to remove caked residue when required. On installations using Linear Heat Detection Cable, insure that the cable is secured to the vehicle and free from abrasion. The Linear Heat Detection Cable may be pressure washed to removed caked residue. Operate the equipment then depress and hold the "TEST" button on the display panel to confirm proper fire relay operations. Check all manual actuation points to insure that tamper indicators are in place, that operating instructions are clearly legible, and that access is unobstructed. Finally, check that all nozzles are unobstructed and that blow-off caps are in place.

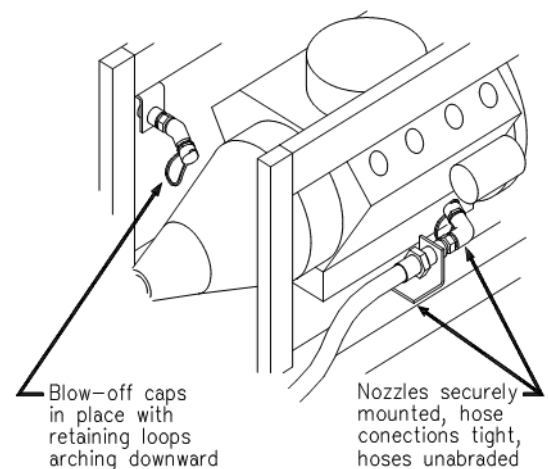

PROTECTING AGAINST FIRES OUTSIDE THE HAZARD AREAS: Make sure that all vehicles are equipped with sufficient portable extinguishers to suppress fires in areas not covered by the fixed nozzles of the vehicle fire suppression system. Your Amerex Distributor can provide the proper size and type of portable extinguisher required.

tape

tape

-----fold here-----

PLACE
STAMP
HERE

AMEREX CORPORATION
Vehicle Systems Group
Warranty Registration Department
P.O. Box 81
Trussville, Alabama
35173-0081

-----Tear or cut at perforations-----

RETURN MAIL INSTRUCTIONS:

1. Fill out reverse side (page 12) completely.
2. Tear off entire sheet along vertical perforation. Tear off this instruction tab along horizontal perforation.
3. Fold card one time along the scored line so that "Amerex Address" printing is facing outward, and warranty information is folded inward.
4. Place two pieces of tape over the printed word "TAPE" along the bottom edge of the card.
5. Apply postage and drop folded taped card in mailbox.

**AMEREX VEHICLE FIRE SUPPRESSION SYSTEM
WARRANTY REGISTRATION FORM**

In order that we may fulfill obligations of the warranty on this Amerex Vehicle Fire Suppression system, please complete the requested below and return within 15 days of installation of the system per instructions on the reverse side of this form.

VEHICLE OWNER INFORMATION:

Name: _____

Company: _____

Address: _____

Phone: _____

SYSTEM INSTALLER INFORMATION:

Name: _____

Company: _____

Address: _____

Phone: _____

Date of Installation: _____

Vehicle Identification Number (VIN No.) _____

SYSTEM DESCRIPTION:

Agent Cylinder: Model _____ Serial No. _____

Number of nozzles this agent cylinder: _____ Number of Manual Actuators used: _____

Electrical/Manual Actuators used: YES _____ NO _____

Circuit Monitor or Control Panel Used (list part no.) _____ Fire Relay Installed: YES _____ NO _____

Owner Signature: _____

Installer Signature: _____

Tear or cut at perforations