

# Veneer Plaster Systems



09 26 13

# VENEER PLASTER SYSTEMS



Veneer plaster expands architectural design limits as with this curved vaulted ceiling.

## DESCRIPTION

Veneer Plaster Systems consist of a 4' wide gypsum plastering base with a special, highly absorptive paper surface that is covered with thinly troweled, special purpose plasters. Two basic types of veneer plaster are available: Uni-Kal and X-KALibur, which are one-coat plaster system products; and Kal-Kote, a two-coat plaster system. The gypsum plaster base, Kal-Kore, is erected in the same manner for both systems. Both veneer plaster systems can be specified for virtually all types of partition and ceiling constructions including wood or steel framing or furring and masonry. For both residential and commercial buildings, either type of veneer plaster system produces a wall more nail-pop resistant than drywall and, when properly installed, more crack resistant than conventional lath and plaster.

### ADVANTAGES - GENERAL

The advantages of veneer plaster over other commonly used partition and ceiling systems include:

1. Rapid installation which reduces overall construction time.
2. Appearance and surface of conventional plaster at lower cost than regular plastering.

3. High resistance to cracking, nail-popping, impact and abrasion failure.
4. Mill-mixed plaster components help ensure uniform installation performance and finished job quality.

### ADVANTAGES - ONE-COAT SYSTEM (UNI-KAL/X-KALIBUR)

1. Requires only one plastering material on the job.
2. Slightly lower in-place cost than two-coat system.
3. Can be applied directly to concrete block.
4. X-KALibur is formulated to have extended set characteristics beyond traditional Uni-Kal setting times.

### ADVANTAGES - TWO-COAT SYSTEM (KAL-KOTE)

1. Kal-Kote System may be used for plaster-embedded electric radiant heating cable systems.
2. Same application techniques as for conventional plaster.
3. Greater crack resistance than one-coat systems.
4. Can be applied directly to concrete block.

### LIMITATIONS

1. Not recommended for exterior use or where subject to weathering, direct water contact or temperature exceeding 125°F (52°C) for extended periods of time.
2. Framing spacing is limited and partition heights are reduced in comparison with some standard constructions.

3. Provides less rigidity than similar standard plaster systems.
4. When Uni-Kal/X-KALibur will be applied, do not install Kal-Kore too far in advance of plastering since Uni-Kal/X-KALibur bond can be adversely affected if face of Kal-Kore has become faded from light. If Kal-Kore has been faded, apply Kal-Kote Base Plaster or a bonding agent to obtain good bond.
5. All are designed for trowel application. Gold Bond Veneer Plasters are not suitable for conveyance or application by conventional plastering machines.
6. Compared to conventional plasters, Veneer Plaster Systems are more subject to beading (ridging) and cracking at the joints under rapid drying conditions such as those caused by low humidity, high temperature and/or high draft exposure.
7. All provide a base over which paints or other finishes should be applied.
8. Do not use a polyethylene vapor retarder unless structure is ventilated adequately during application of veneer plasters.
9. A bonding agent must be applied to monolithic concrete prior to application of either system.
10. Mix only full bags of plaster for proper set.
11. Do not use self-adhesive mesh tape.



Kal-Kore boards are screwed to steel studs or nailed or screwed to wood studs to form a base.



Joints are reinforced with Kal-Mesh fiberglass webbing. Steel corner and casing beads protect corners.



Kal-Kote is applied in 2 coats, a base and a finish, to form a hard-surfaced, 1/8" total thickness.

**TECHNICAL DATA**

**GOLD BOND® BRAND KAL-KORE PLASTER BASE**

Kal-Kore is a tapered edge gypsum plaster base having a blue absorptive face paper surface designed to permit rapid trowel application and strong bond of Kal-Kote, Uni-Kal and X-KALibur plasters. Also available foil backed or Fire-Shield (type X). Kal-Kore is manufactured to conform to ASTM Specification C 1396 and CSA A82.27.

**GOLD BOND® BRAND HI-ABUSE KAL-KORE PLASTER BASE**

Gold Bond BRAND Hi-Abuse Kal-Kore Fire-Shield Type X Plaster Base boards consist of a fire resistive Type X gypsum core encased in a heavy, blue absorptive face paper designed to permit rapid trowel application and strong bond of Uni-Kal veneer plaster and strong liner paper on the back side. Gold Bond BRAND Hi-Abuse Kal-Kore Fire-Shield Type X Plaster Base features a specially formulated core to provide fire resistance ratings when used in tested systems as well as greater resistance to surface indentation. Long edges of the boards are tapered to allow joints to be reinforced and concealed with Kal-Mesh Tape and Uni-Kal Plaster. Gold Bond BRAND Hi-Abuse Kal-Kore Fire-Shield Type X Plaster Base is manufactured to conform to ASTM Specification C 1396 and Federal Specification SS-L-30D Type VI Grade X (Fire-Shield).

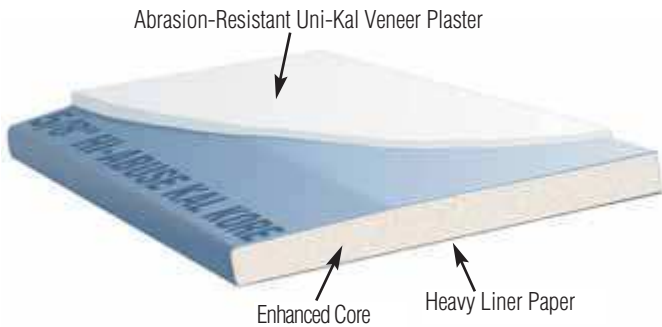

Size	Thickness	Edge	Pcs. per Bdl.
4'x8', 16' (1219 mm x 2438 mm, 4877 mm)	3/8" (9.5 mm)	Square or Tapered	2
4'x8', 16' (1219 mm x 2438 mm, 4877 mm)	1/2" (12.7 mm) 1/2" (12.7 mm) FSK-C	Square or Tapered	2
4'x8', 16' (1219 mm x 2438 mm, 4877 mm)	5/8" (15.9 mm) FSK	Square or Tapered	2
4'x8', 12' (1219 mm x 2438 mm, 3657 mm)	1/2" (12.7 mm) 5/8" (15.9 mm) FSK Hi-Abuse	Square or Tapered	2

09 26 13

### **KAL-KOTE BRAND BASE PLASTER**

Kal-Kote Base Plaster is a specially designed high strength basecoat plaster for application 1/16" minimum thickness over Kal-Kore, masonry or monolithic concrete that has been treated with a bonding agent.

Strength of Kal-Kote Base is substantially greater than that exhibited by typical sanded basecoat plaster.

#### **Fire Resistance**

Fire ratings equivalent to those of drywall systems can be obtained by applying the corresponding Kal-Kore type and thickness over the same framing member size and spacing, with the same fasteners. The total plaster thickness should be a minimum of 1/8". The minimum 1/8" thickness is achieved by applying a finish not exceeding 1/16" over 3/32" of Kal-Kote Base Plaster.

#### **Specification Reference**

ASTM Designation C 587.

#### **Bag Weight**

80 lbs. (36.3 kg)

#### **Water Ratio**

10-12 quarts per bag

#### **Coverage (est.)**

1/16" on Kal-Kore Base, 425-475 sq. yds. per ton (150-170 sq. ft. per bag). One coat to level over masonry, 225-275 sq. yds. per ton (80-100 sq. ft. per bag).

### **KAL-KOTE BRAND SMOOTH FINISH PLASTER**

Kal-Kote Smooth Finish is designed to provide a white smooth trowel finish using conventional plastering techniques. Apply not exceeding 1/16" over Kal-Kote Base.

Requires the addition of water only. It may also be used as a finish for conventional basecoat plasters. Small amounts of commercial retarder may be cautiously used to slow the setting time when used over conventional basecoat plasters.

#### **Bag Weight**

50 lbs. (22.7 kg)

#### **Water Ratio**

18-20 quarts per bag

#### **Coverage (est.)\***

1/16" coat troweled on Kal-Kote Base Plaster, 650-700 sq. yds. per ton (145-160 sq. ft. per bag).

### **KAL-KOTE BRAND TEXTURE FINISH PLASTER**

Kal-Kote Texture Finish is designed to provide a variety of decorative surfaces using common plastering techniques. Applied as a 1/16" finish coat over Kal-Kote Base. It requires the addition of water only.

#### **Bag Weight**

50 lbs. (22.7 kg)

#### **Water Ratio**

11-12 quarts per bag

#### **Coverage (est.)\***

1/16" coat troweled on Kal-Kote Base Plaster, 650-700 sq. yds. per ton (145-160 sq. ft. per bag).

### **UNI-KAL AND X-KALIBUR BRAND VENEER PLASTER**

Uni-Kal and X-KALibur are single component veneer plasters for application over tapered edge 1/2" Regular or 5/8" Fire-Shield Kal-Kore, 5/8" Kal-Kore Hi-Impact or as a finish coat over Kal-Kote base. When applied in a thin coat 3/32" thick and troweled to a smooth finish, they provide a durable, abrasion-resistant surface for further decoration. X-KALibur has a longer extended working time.

Uni-Kal and X-KALibur may be worked to a variety of textured finishes.

Uni-Kal and X-KALibur applied not exceeding 1/16" may be used as a finish coat over a 3/32" coat of Kal-Kote Base Plaster for a total minimum thickness of 1/8".

Strength of Uni-Kal and X-KALibur provides a surface resistant to abrasion, cracking and nail-pops.

#### **Fire Resistance**

Fire ratings equivalent to those of drywall systems can be obtained by applying the corresponding Kal-Kore type and

thickness over the same framing member size and spacing with the same fasteners and 3/32" of Uni-Kal or X-KALibur.

#### **Specification Reference**

ASTM Designation C 587.

#### **Bag Weight**

50 lbs. (22.7 kg)

#### **Water Ratio**

13-15 quarts per bag

#### **Coverage (est.)\***

3/32" on Kal-Kore Base, 600-665 sq. yds. per ton (135-150 sq. ft. per bag). One coat to level over masonry, 300-350 sq. yds. per ton (70-80 sq. ft. per bag).

\*Coverage estimates are approximately the same as over Kal-Kore Base Board for conventional plasters.



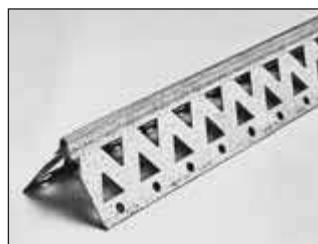

**KAL-KORNER BEAD**  
Formed of galvanized steel to protect exterior corners with veneer plastering. Flange length 1 1/4" .



**E-Z STRIP® CONTROL JOINT**  
Designed for drywall or veneer plaster systems. A vinyl extrusion used as an expansion or control joint for ceilings or partitions.

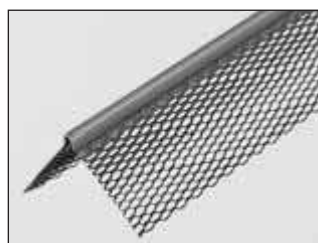

**EXPANDED VENEER CORNERBEAD**  
Used as an alternate to the Kal-Korner Bead for exterior corners. 1 1/4" flanges.



**KAL-MESH TAPE**  
A coated non-adhesive fiberglass tape which is stapled to Kal-Kore to reinforce all joints and interior angles.

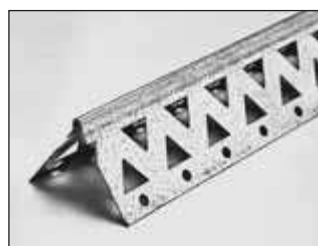

**ARCH CORNERBEAD**  
Can be used straight for exterior corners or flanges, or may be snipped and bent to form arches.



**.093 ZINC CONTROL JOINT**  
Designed as an expansion or control joint for ceiling and partition areas for both drywall or veneer plaster systems.



**VENEER J TRIM CASING BEAD**  
Used as a finished edge at door and window jambs by slipping over edge of plaster base.



**1 1/2" DRYWALL FURRING CHANNEL CLIP**  
Attaches Screw Furring Channel to 1 1/2" cold rolled steel channel.

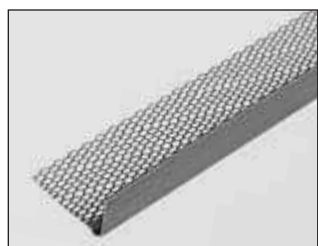

**VENEER L TRIM CASING BEAD**  
Used as a finished edge at door and window jambs.

\*Metal products are not manufactured by National Gypsum Company.

09 26 13

### FASTENERS FOR ATTACHING KAL-KORE

Framing	Kal-Kore	Fastener	Fastener Spacing
Steel Studs & Furring	1/2" (12.7 mm)	Type S Screws 1" (25.4 mm) for single layer	12" o.c. Max. (305 mm)
	5/8" (15.9 mm)	1 5/8" (41.3 mm) for two-ply	
	3/8" (9.5 mm)	1 1/4" (31.8 mm) annular or 4d box nails**	Ceiling 7" o.c. (178 mm) Max.
Wood Framing	1/2" (12.7 mm)	1 1/4" (31.8 mm) annular or 5d box nails**	Sidewall 8" o.c. (203 mm) Max.
	5/8" (15.9 mm)	1 3/8" (34.9 mm) annular or 6d box nails**	

\*\* Alternate: On walls, 1 1/4" (31.8 mm) Type W screws are spaced 12" (305 mm) when framing is 24" o.c. (610 mm) or 16" o.c. (406 mm).

TABLE 1—SPACING OF FRAMING OR FURRING

Type of Framing or Furring	Kal-Kore Thickness	Maximum Spacing on center
Wood	3/8" (9.5 mm)	*16" (406 mm)
	1/2" (12.7 mm)	**24" (610 mm)
	5/8" (15.9 mm)	24" (610 mm)
***Metal	3/8" (9.5 mm)	N.A.
	1/2" (12.7 mm)	16" (406 mm)
	5/8" (15.9 mm)	24" (610 mm)

N.A.—Not Approved.

\* Bound edge of Kal-Kore must be at right angles to framing for ceiling or walls.

\*\* Bound edge of Kal-Kore must be at right angles to joists. 16" (406 mm) maximum spacing for bound edge of Kal-Kore parallel to joists.

\*\*\* On ceilings, furring channel [7/8" (22.2 mm) depth] shall span 48" (1219 mm) maximum. Resilient furring channel [1/2" (12.7 mm) depth] shall span 24" (610 mm) maximum. For greater spans, 1 5/8" (41.3 mm) Steel Studs may be used as Ceiling Furring Channels provided they are secured with flanges up (open side up) at spans not to exceed: 6' (1829 mm) at 12" o.c. (305 mm) spacing, 5'6" (1676 mm) at 16" o.c. (406 mm) spacing and 5' (1524 mm) at 24" o.c. (610 mm) spacing.

Note: Veneer Plaster Systems are to be installed with maximum deflection criteria of L/240.



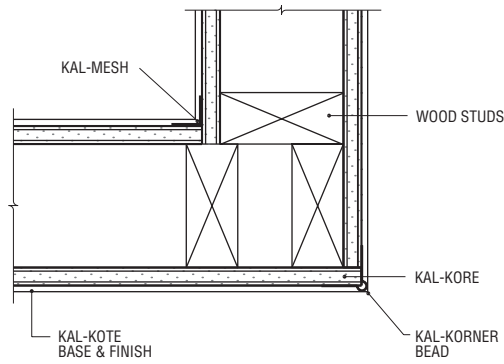

**CORNER-WOOD STUDS**

09215A

Scale: 2 1/4" = 1'-0"

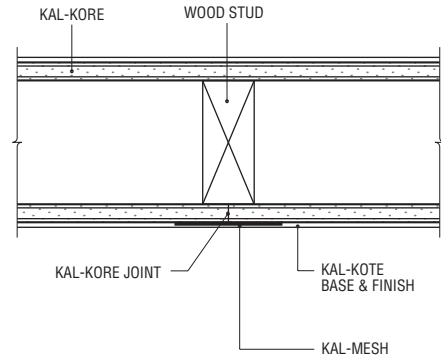

**JOINT DETAIL**

09215C

Scale: 2 1/4" = 1'-0"

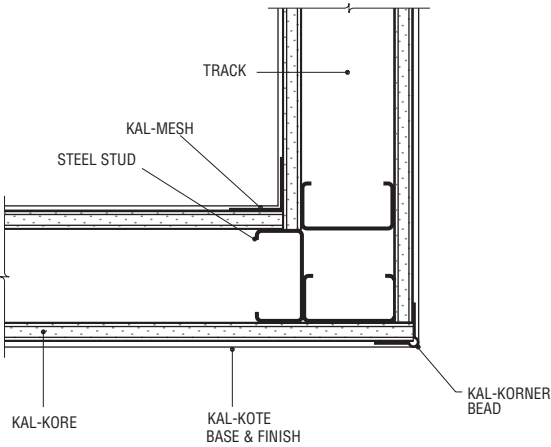

**CORNER-STEEL STUDS**

09215B

Scale: 2 1/4" = 1'-0"

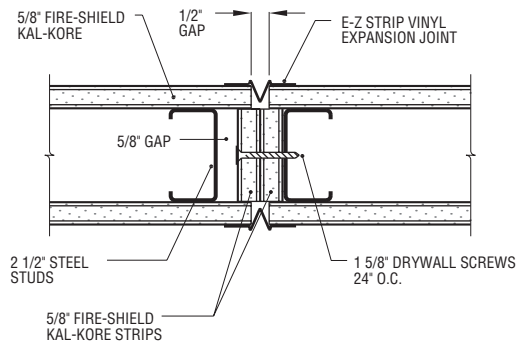

**ONE HOUR FIRE RATED CONTROL JOINT DETAIL**  
Based on Warnock-Hersey Report No. WH-651-0318.1  
and Factory Mutual Design No. W1B-1 hr.

09215D

Scale: 2 1/4" = 1'-0"

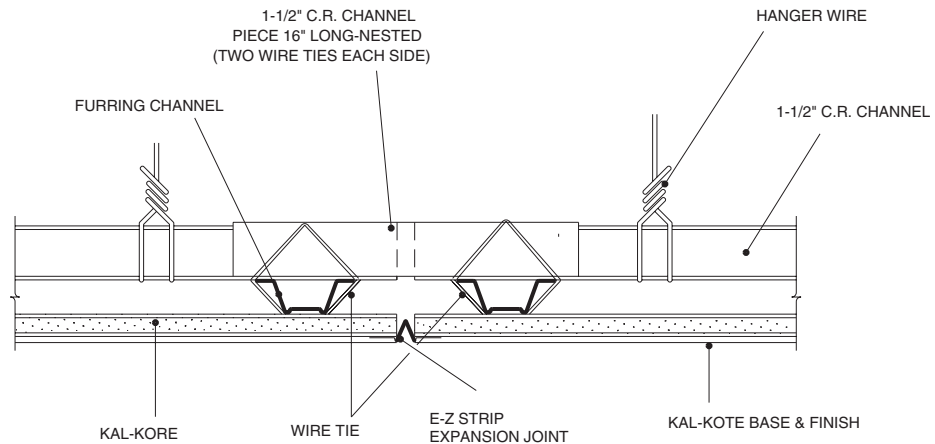

**SUSPENDED VENEER PLASTER CONTROL JOINT**

09215E

09 26 13

**VENEER PLASTER FOR METAL AND WOOD FRAMING**

**1. Wood Studs or Joists.**

Wood members shall meet the minimum requirements of local building codes. Framing shall not exceed spacing shown in Table 1 on page 46. Most partition fire ratings require that Kal-Kore be applied vertically. When such ratings are not required, horizontal application may be used to minimize joints. For ceilings, application at right angles to framing is preferred.

**2. Metal Studs.** Align floor and ceiling tracks to ensure plumb partition. Secure track with appropriate fasteners at a maximum of 24" o.c. Position studs in track on specified centers by rotating into place for a friction fit. Secure studs located adjacent to door and window frames, partition intersections and corners by self-drilling sheet metal screws through both flanges of studs and tracks or by use of steel stud clinching tool. Apply Kal-Kore vertically for most fire ratings. When ratings are not required, horizontal application may be used to minimize joints.

**3. Masonry Wall Furring with Screw Furring Channel.** Attach furring channel vertically spaced not to exceed spacing shown in Table 1 on page 44. Fasten

each channel with concrete stub nails or appropriate fasteners through channel flanges into the masonry or concrete. Fasteners shall be spaced on alternate flanges not over 24" o.c. Apply Kal-Kore vertically or horizontally in maximum lengths to minimize end joints.

**4. Furred Ceilings with Bar Joists.** Attach regular furring channel 16" o.c. to bar joists spaced up to 4' o.c. Resilient Furring Channel (wire-tied only) shall span a maximum of 24". Wire tie Furring Channel to joists or use 1 1/2" Drywall Furring Channel Clip for 1 1/2" carrying channel. Apply Kal-Kore with paper bound edges at right angles to the furring channel.

**KAL-KORE AND HI-ABUSE® KAL-KORE APPLICATION**

**Note:** Application shall conform to ASTM C 844.

1. Cut and position Kal-Kore accurately. Bring all joint edges together but do not force into place. Position all end joints over framing members. To avoid ridging, minimize gaps between adjacent boards.
2. Minimize the number of end joints by using maximum practical lengths with proper positioning.
3. Stagger joints so that they occur on different framing members and will not be directly opposite one another on partitions.

Avoid joining Kal-Kore at corners of doors, window frames, and other openings, unless control joints are created using E-Z Strip Control Joints.

4. Fasten Kal-Kore to framing members with face out, using the proper type and spacing of fasteners shown under types of fasteners.
5. Draw Kal-Kore tight to framing. Drive fasteners straight and dimple the surface without breaking the paper face.

**KAL-KORNER BEAD APPLICATION**

Install Kal-Korner Bead using appropriate fasteners spaced 12" apart.

**E-Z STRIP CONTROL JOINT APPLICATION**

Install E-Z Strip Control Joint at 30' max. spacing on walls and 50' max. spacing in either direction on ceilings. Apply the control joint with staples spaced 6" along each side of the flanges.

**TREATMENT OF KAL-KORE JOINTS**

Pre-treat all joints and fasteners in Kal-Kote and Uni-Kal Plaster Systems with Kal-Kote Base Plaster, Uni-Kal, X-KALibur or Sta-Smooth Joint Compound.

Low humidity, high temperatures and rapidly circulating air can cause cracking of plaster and joint beading when Kal-Kore is

applied to metal framing. To minimize this during these conditions, joints may be pre-treated using paper tape.

Three acceptable methods of treating Kal-Kore joints are:

**DRYWALL PAPER TAPE TREATMENT METHOD**

1. Trowel Kal-Kote Base Plaster, Uni-Kal or X-KALibur over joint line filling the channel formed by the tapered edges of the Kal-Kore board in an even fashion.
2. Center drywall paper tape over the joint line and embed the tape into the soft plaster using a trowel and level the joint. Tape the full length of the joint.
3. Allow the treated joints to set *prior* to general plaster application.





### STA-SMOOTH PAPER TAPE TREATMENT METHOD

1. Mix Sta-Smooth Compound per instructions on package. Do not contaminate the compound with other materials, dirty water or previous mixes. Do not retemper.
2. Apply the Sta-Smooth Compound to the joint by hand or machine tool. The drywall paper tape must be centered over the joint line and embedded into the soft compound. Do not over-trowel to a slick surface. Leave the surface rough to provide mechanical keying of the plaster.
3. Allow the treated joints to set and dry *prior* to general plastering.

### KAL-MESH TREATMENT METHOD

Do not use self-adhering mesh.

1. Center and secure Kal-Mesh over all joints and interior angles with 1/4" or 5/16" staples.
2. Position staples a maximum of 24" apart as follows:
  - A. Joints: at alternate edges for the run from end to end and directly opposite one another at either end.
  - B. Angles: along ceiling edge only for wall-to-ceiling angles. Along one edge for wall-to-wall angles.
3. After the first staples are placed at the end of a joint or angle, pull unstapled Kal-Mesh as stapling proceeds to ensure that it will lie flat against the Kal-Kore.
4. Pre-treat all joints and Kal-Beads with Kal-Kote, Uni-Kal or X-KALibur Plaster. Tightly trowel over joint line in both directions to prevent voids, feathering to a maximum width of about 6".
5. Allow the treated joints to set *prior* to general plaster application.

### PLASTERING

Note: Application shall conform to ASTM C 843.

The same general job conditions used in good conventional plastering practice should be maintained. However, because Veneer Plaster coats are thin, particular action must be taken to

guard against dryouts (primarily avoiding direct exposure to concentrated sources of heat and drafts.)

Special attention should also be given to temperature conditions under which the system is installed. Both "in-place" and application performance of individual Veneer System components will be greatly enhanced if all construction areas and materials are at a suitable temperature equilibrium before, during and after installations. During cold weather, maintain a temperature 55°F (13°C) to 70°F (21°C) before, during and after installation of all system components until veneer plaster has dried.

### MIXING

Equipment: Mixing should be done with a high-speed mechanical mixer. A paddle-type agitator fitted to a 500-600 RPM heavy duty, 1/2" electric drill and a clean, smooth-sided drum of convenient size are recommended for rapid, efficient mixing of all Kal-Kote Plaster types.

Water Ratios: Use only clean, fresh water suitable for human consumption.  
 Basecoat: 10-12 qts. per 80 lb. bag. Smooth Finish: 18-20 qts. per 50 lb. bag.  
 Texture Finish: 11-12 qts. per 50 lb. bag. Uni-Kal and X-KALibur: 13-15 qts. per 50 lb. bag.

### PROCEDURE

1. Put all but 1 to 2 qts. of the proper water volume in a suitable mixing drum.

**Note:** Starting with an insufficient amount of mixing water will seriously degrade mixing and application performance.

2. Add plaster and allow to soak for about 1 minute or add plaster as mixer is turning, then mix until uniformly wetted.
3. Add remaining water and mix sufficiently to obtain desired lump-free material fluidity.

### Note:

- A. Mixing periods greater than 5 minutes will not be required if proper equipment and procedure are used.
- B. Mix no more than two bags per batch to avoid mixing too far in advance of application.



- C. Caution is advised against mixing more than two successive batches without thorough equipment clean-up to avoid undue set acceleration.
- D. Avoid the practice of mixing partial bags since this leads to difficulty in maintaining uniform material qualities.

### JOB SETTING ADJUSTMENT

1. Basecoat and Finish Plasters: Small amounts of commercial retarder or commercial gypsum type accelerator may be cautiously used to adjust setting time when extreme conditions demand. When commercial retarder or accelerator is used, add to mixing water directly, or in previously prepared water solution form to obtain the most uniform effect.
2. Never use gauging or moulding plasters in place of commercial accelerator since they can adversely affect working qualities.

### KAL-KOTE APPLICATION OVER KAL-KORE

#### Basecoat Over Kal-Kore

1. Tightly scratch material into previously treated joints and cornerbeads, then immediately scratch-in tightly over the wall and/or ceiling area.
2. Double back over the area just troweled with material from the same batch, bringing total thickness up to 1/16" minimum.
3. When plaster has "taken up," eliminate excessive trowel marks and fill all surface voids and imperfections to obtain a reasonably uniform surface. Do not over-trowel to a slick surface. Roughen the unset basecoat plaster surface with a serrated darby or lightly wire rake to provide mechanical keying

for the finish plaster when necessary.

#### Smooth Finish Over Basecoat

1. Apply only over properly prepared Kal-Kote basecoat plaster. Scratch-in tightly, then double back with material from the same batch immediately to create a uniform coat not exceeding 1/16" in average thickness.

2. Remove trowel marks, "cat faces," and other major surface imperfections by "drawing-up" or "laying down" the surface with light trowel pressure when plaster has stiffened.

Use water sparingly if needed, but do not over-trowel or over-water because this aggravates any normal tendency for blistering when working over low suction bases. Such blistering will be eliminated by the final water-troweling operations.

3. Water-trowel to densify and polish the surface to the desired degree when plaster has set, eliminating any blistering if present. Never use a felt "blister brush" as a substitute for water troweling!
4. Uni-Kal and X-KALibur Plaster may be substituted for Kal-Kote Smooth Finish.

#### Texture Finish Over Basecoat

1. Apply per (1) under Smooth Finish.
2. When plaster has stiffened, float its surface to any desired finish.

Do not float the soft surface of plaster which has already set.

Up to equal parts by weight of clean, graded silica sand may be added to Uni-Kal and X-KALibur to aid texturing.



#### UNI-KAL OR X-KALIBUR APPLICATION OVER KAL-KOTE

1. Tightly scratch material into previously treated joints and cornerbeads, then immediately scratch-in tightly over the wall and/or ceiling area.
2. Double back over the area just troweled with material from the same batch bringing total thickness up to 3/32" minimum.
3. Begin finish troweling at time of initial set, using water sparingly. Final troweling must be accomplished before complete set takes place, as evidenced by darkening of the surface.

**Note:** Uni-Kal or X-KALibur may be applied to produce a textured finish.

- A. When Uni-Kal or X-KALibur is mixed, add up to but not exceeding 50 lbs. of silica sand, texturing grade, per 50 lb. bag of plaster.
- B. The sanded Uni-Kal or X-KALibur mix should be scratched-in tightly over the plastering base. Immediately double back over the area just troweled with material from the same batch.
- C. When plaster is well taken up, float to the desired texture finish.

#### VENEER PLASTERS DIRECT TO BOND-COATED MONOLITHIC CONCRETE

##### DESCRIPTION

The Kal-Kote System, consisting of a basecoat plaster and a finish coat plaster, Uni-Kal or X-KALibur may be applied directly to monolithic concrete treated with a bonding agent.

##### LIMITATIONS

1. Surface to be plastered shall be treated with a bonding agent applied according to manufacturer's directions. The performance of this system is the sole responsibility of the bonding agent manufacturer.
2. Concrete should be aged at least one month prior to plastering.
3. Kal-Kote Smooth or Texture Finishes are not designed for direct application to concrete, but must first have Kal-Kote Base Plaster applied to fill and level surface.
4. Do not apply system to the interior side of exterior walls below grade. To use above grade these walls shall be kept dry and shall have been properly waterproofed on the exterior side to prevent water penetration.

#### APPLICATION PROCEDURES

**Note:** Application shall conform to ASTM C 843.

##### Kal-Kote Base Application Over Bonding Agent

1. First straighten any major surface irregularities, such as holes, ridges, wavy sections, etc. Scratch plaster in tightly by trowel and fill out to any adjacent level area.
2. After the straightening material has set, trowel in a tight scratch coat over the entire area to be plastered; then immediately double back with material from the same batch to minimum thickness of 1/16" or as required to achieve a level surface. Use a rod or feather edge if needed.
3. When plaster has "taken up," eliminate excessive trowel marks and fill all surface voids and imperfections to obtain a reasonably uniform surface. Do not trowel to a slick surface. Roughen the unset basecoat plaster surface with a serrated darby or lightly wire rake to provide mechanical keying for the finish plaster when necessary.

##### Smooth or Textured Finishes

Apply finishes to the Kal-Kote Plaster as outlined under the regular Kal-Kote System as described on page 49.

##### Uni-Kal or X-KALibur Application Over Bonding Agent

1. First straighten any major surface irregularities such as holes, ridges, wavy sections, etc. Scratch plaster in tightly by trowel and fill out to any adjacent level area.
2. Allow the straightening material to set.
3. Tightly scratch material in over the wall and/or ceiling area. This application should be about 1/16" thick. Double back over the area just troweled with material from the same batch, bringing total thickness up to 3/32" minimum.
4. Begin finish troweling at time of initial set, using water sparingly. Final troweling must be accomplished before complete set takes place, as evidenced by darkening of the surface.



**Veneer plaster performs well in high traffic areas such as stairways and halls.**



Veneer plaster walls are particularly suited to accommodate wall situations where light conditions require smooth, even expanses of wall.



The Veneer plaster wall system is particularly suited to residential and commercial construction in areas which need strength for special architectural details, and unusual design elements.

#### VENEER PLASTERS DIRECT TO UNIT MASONRY

##### DESCRIPTION

The Kal-Kote System, consisting of a basecoat plaster and a finish coat plaster, Uni-Kal or X-KALibur, the one-coat system, may be applied directly to masonry surfaces providing the following recommendations are followed.

##### RECOMMENDATIONS

1. Surface must be free from dirt, grease, oil, mold, parting agents, or any material which will prevent plaster adhesion.
2. When erecting masonry, strike joints flush. If masonry has recessed joints, fill joints flush to masonry surface with basecoat plaster, Uni-Kal or X-KALibur and allow to set.

##### EXTERIOR CORNERS

Install cornerbead with adhesive at least 4 and preferably 16 hours before plastering. Apply a continuous bead of adhesive approximately 1/4" x 1/4" along the inside of both cornerbead flanges. Press the bead firmly over the corner so that adhesive is in continuous contact with masonry surface. Align bead and allow to stand undisturbed at least 4 hours.

#### KAL-KOTE APPLICATION

**Note:** Application shall conform to ASTM C 843.

Proceed with the full field of the wall by scratching-in tightly, then double back immediately with material from the same batch to a minimum thickness of 1/16" over the block surface, or as required to level.

Kal-Kote Finishes should be kept as thin as possible and applied as described on page 44 and 51.

#### UNI-KAL OR X-KALIBUR APPLICATION

Proceed with full field of the wall by scratching-in tightly, then double back immediately with same batch of material to a minimum thickness of 3/32" over the block surface.

**Caution:** Since Uni-Kal or X-KALibur is a one-coat material system, exercise care in leveling the wall to compensate for the uneven suction.

#### VENEER SYSTEMS APPLIED TO MASONRY WITH Z FURRING CHANNEL SYSTEM

##### DESCRIPTION

This system consists of a Z Furring Channel, rigid insulation and the components of the Kal-Kote

and Uni-Kal or X-KALibur Veneer Plaster Systems. The Z Furring Channel is manufactured from galvanized steel (.0179" min. base steel) and is produced with web depths of 1", 1 1/2" and 2". The furring channel which is applied to a masonry wall holds the insulation in place and the wide flange serves as framing for the application of the Kal-Kote plastering base.

##### LIMITATIONS

1. Since the interior wall surface will take the general configuration of the masonry wall, it may be necessary when applying the system to unit masonry to use portland cement plaster to bring the wall to a plane surface.
2. This system is mainly for new masonry construction. On well-cured concrete or masonry, it may be difficult to properly drive fasteners.
3. Power-driven fasteners shall be used only for attachment to monolithic concrete surfaces.
4. Kal-Kote should be applied within 24 hours of foam application.





Design flexibility is achieved with veneer plaster systems.

#### APPLICATION PROCEDURES

1. Begin application of Z Furring members by positioning first channel vertically at a corner, locating it on the wall adjacent to the wall being insulated first.

The insulation thickness determines the distance of Z Furring web from wall being insulated. At the appropriate distance, with wide flange pointing toward applicator, secure Z Channel with appropriate fasteners, spaced 24" o.c. driven through short flange. (Note: Power-driven fasteners are not recommended for use with masonry block.)

Install 24" wide floor-to-ceiling insulation board, pressed snugly against web of first Z. Install next Z with the wide flange overlapping the edge of the first insulation board. Fasten Z to wall through narrow flange. Continue in this manner with Z Furring member 24" o.c. to end of wall. Locate last Z so that web is located a distance equal to insulation thickness from adjoining wall. Cut last insulation board to fit remaining space.

At exterior corner, attach the Z through its wide flange with narrow flange extending beyond the corner. Begin with a narrow strip of floor-

to-ceiling insulation, wider than insulation thickness, but not exceeding 3". Continue application of furring and insulation progressively as described above.

At windows, doors and trim areas, use wood nailers, nominal 2" wide x insulation thickness plus 1/32". Use the nailers also at wall-floor angles to support trim and provide backing for base.

2. Apply Kal-Kore to the flanges of Z Channel with 1" Type S screws spaced 12" o.c. Normally, vertical application of Kal-Kore is recommended; however, for installations 8' or less in height, horizontal application may be preferred since the number of joints would be reduced.
3. Apply Kal-Mesh and Kal-Korner Bead according to procedures described on page 50 and 51.
4. Mix and trowel on Kal-Kote Base and Finish Plaster or Uni-Kal Plaster as described on pages 46, 51 and 52.

#### PAINTING PLASTER

Various job conditions such as suction differences, wet or only partially dry walls, and reactions between paint and lime may cause unsatisfactory paint finishes, particularly on new construction.

Alkali-resistant primers specifically formulated for use over new plaster will permit decorating with oil or latex type paints. Quality paint products should be used and manufacturers' recommendations followed. Finished plaster should be painted or covered to conceal possible discoloration. The paint system should be suitable for use over plaster surfaces that contain lime, which has a high pH of 10-13.

It is essential that plaster be sound and completely dry before painting. Under good drying conditions, veneer plaster may be painted 48 hours after application.

High build, heavy duty and special purpose coatings such as Epoxy are not recommended over veneer or job gauged lime putty finishes.

In all cases, the paint manufacturer should be consulted and approve paint system suitability for use with gypsum/lime finish plaster.

#### STORAGE

Gypsum plaster must be kept dry before use. Storage conditions vary with location and seasonal changes, which may affect storage life. These conditions may affect product characteristics such as setting time, working qualities, component separation, or lumping, etc. Such aging is normally a function of exposure to humid air, temperature, and physical support in warehousing. Adverse storage conditions or prolonged storage may affect the working qualities of the product. Rotate inventory frequently for best results.



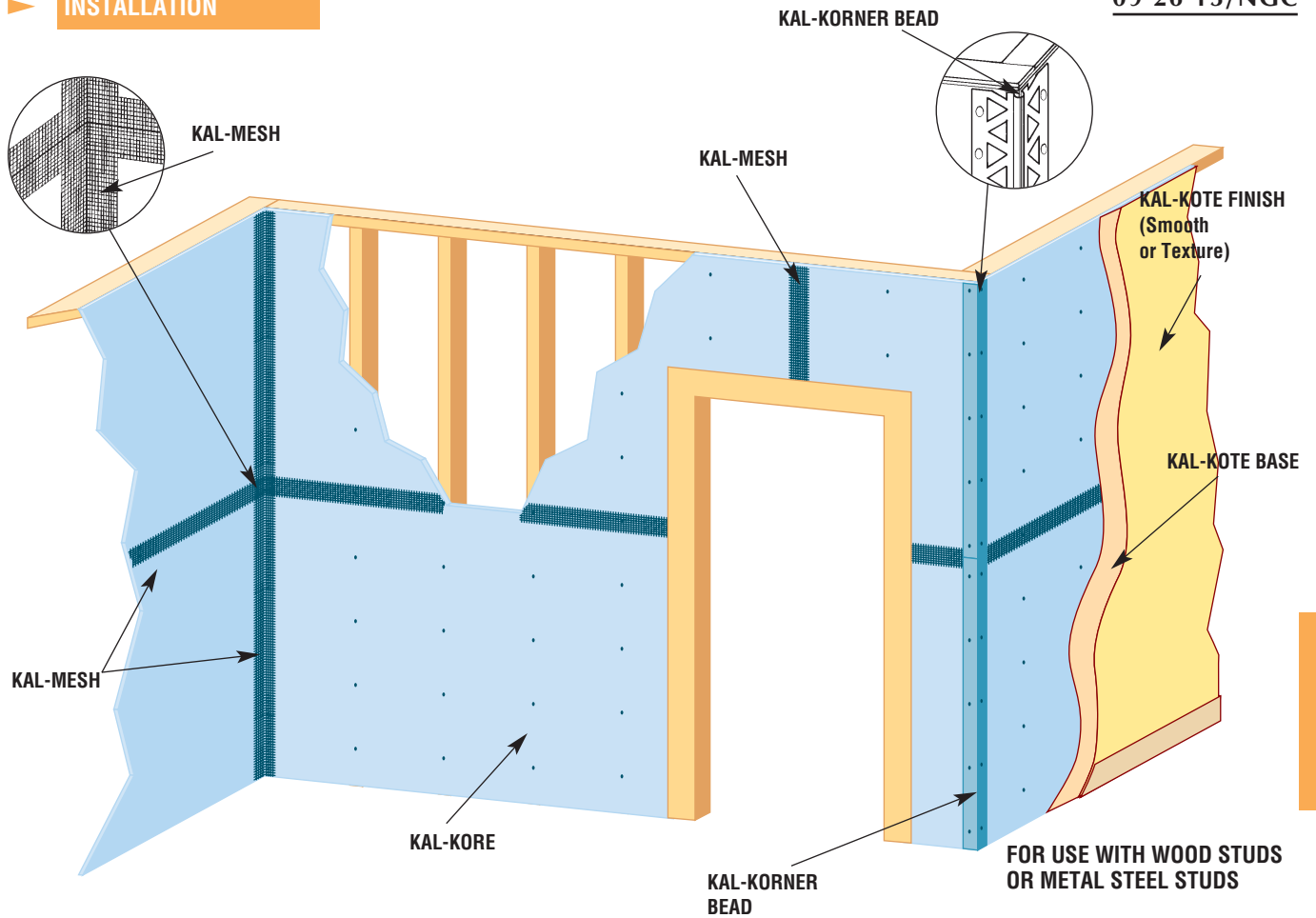

09 26 13

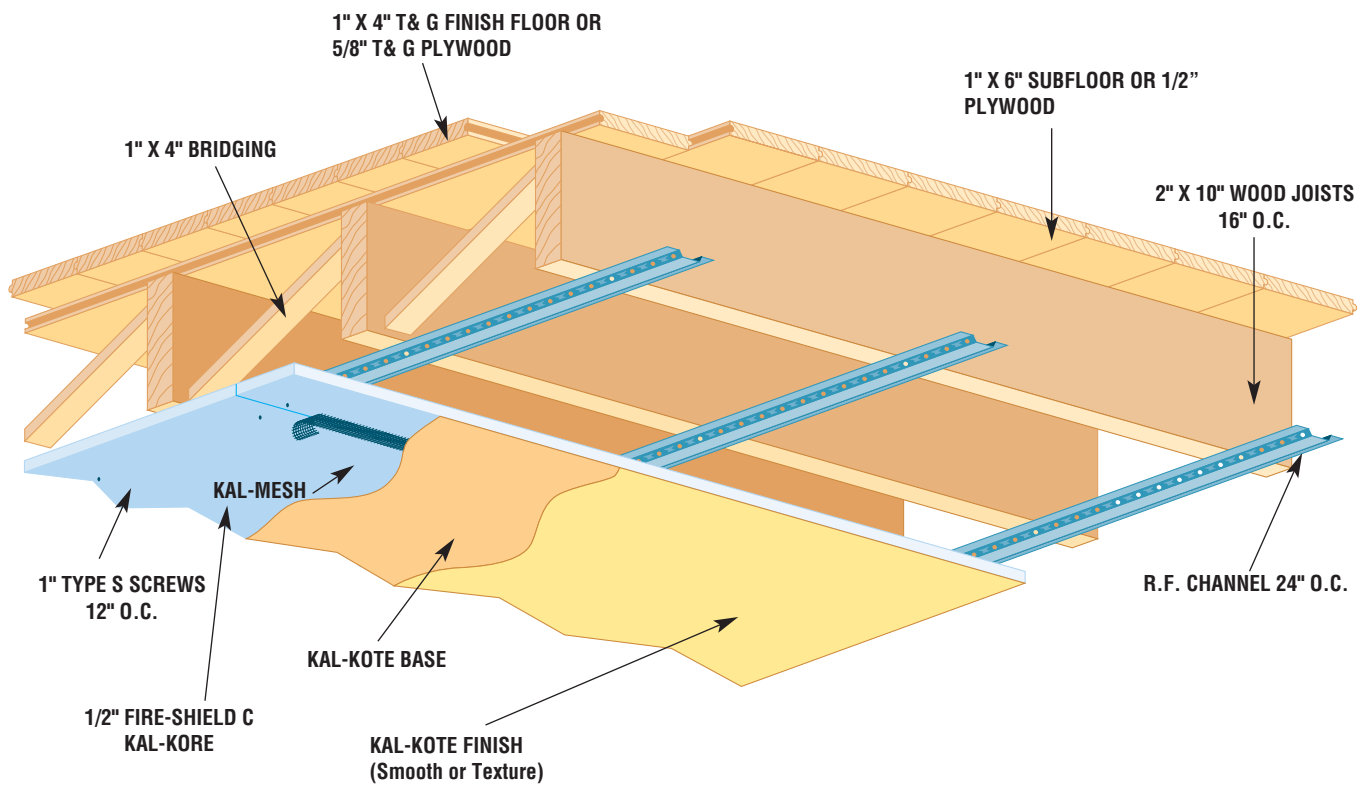

U.L. DESIGN L515

**SECTION 09 26 13**

**VENEER PLASTER**

THE FOLLOWING PARAGRAPHS ARE FOR INSERTION INTO SECTIONS OF GENERIC SPECIFICATIONS OR GENERIC/PROPRIETARY SPECIFICATIONS COVERING VENEER PLASTER PRODUCTS. THE NATIONAL GYPSUM COMPANY PRODUCT NAME FOLLOWS THE GENERIC DESCRIPTION IN PARENTHESES.

**PART 1 GENERAL**

1.02 REFERENCES

- A. American Society for Testing and Materials (ASTM):
  1. C 587, Specification for Gypsum Veneer Plaster.
  2. C 1396, Specification for Gypsum Board (Gypsum Base for Veneer Plaster).
  3. C 843, Specification for Application of Gypsum Veneer Plaster.
  4. C 844, Specification for Application of Gypsum Base to Receive Gypsum Veneer Plaster.

**PART 2 PRODUCTS**

2.01 MANUFACTURER

- A. National Gypsum Company

2.02 MATERIALS

A. Veneer Plaster Base:

1. Regular: A gypsum core lathing board surfaced with absorptive paper on front, and long edges and complying with ASTM C 1396 (Gold Bond BRAND Kal-Kore Plaster Base).
  - a. Thickness: 3/8" or 1/2"
  - b. Width: 4'
  - c. Length: 8' through 16'
  - d. Edges: Tapered
2. Fire-Resistant: A gypsum core lathing board with additives to enhance the fire resistance of the core and surfaced with absorptive paper on front, and long edges and complying with ASTM C 1396, Type X.
  - a. Thickness: 1/2" (Gold Bond BRAND Kal-Kore Fire-Shield C Plaster Base) or 5/8" (Gold Bond BRAND Kal-Kore Fire-Shield and Fire Shield C Plaster Base).
  - b. Width: 4'
  - c. Length: 8' through 16'
  - d. Edges: Tapered
3. Regular, Foil-Backed: A gypsum core lathing board surfaced with absorptive paper on front, and long edges; backed with aluminum foil; and complying with ASTM C 1396 (Gold Bond BRAND Kal-Kore Foil-Back Plaster Base).
  - a. Thickness: 1/2"
  - b. Width: 4'
  - c. Length: 8' through 16'
  - d. Edges: Tapered
4. Regular, Abuse-Resistance: A gypsum core lathing board with additives to enhance impact resistance and surfaced with absorptive paper on front and long edges with heavy liner paper bonded to the back side; and complying with ASTM C 1396 (Gold Bond BRAND Hi-Abuse Kal-Kore Plaster Base).
  - a. Thickness: 1/2"
  - b. Width: 4'
  - c. Length: 8' through 12'
  - d. Edges: Tapered

5. Fire Resistant, Abuse Resistant: A gypsum core lathing board with additives to enhance fire and impact resistance and surfaced with absorptive paper on front and long edges with heavy liner paper bonded to the back side; and complying with ASTM C 1396, Type X (Hi-Abuse BRAND Kal-Kore Fire-Shield Plaster Base).

- a. Thickness: 5/8"
- b. Width: 4'
- c. Length: 8' through 12'
- d. Edges: Tapered

B. Gypsum Plaster:

1. Base Plaster: High strength gypsum plaster complying with ASTM C 587 (Kal-Kote BRAND Base Coat Plaster).
2. Finish Plaster: Gypsum plaster for smooth finish complying with ASTM C 587 (Kal-Kote BRAND Smooth Finish Plaster).
3. Finish Plaster: Gypsum plaster for textured finish complying with ASTM C 587 (Kal-Kote BRAND Texture Finish Plaster).

IF TEXTURED FINISH IS SPECIFIED FOR BELOW, SAND MAY BE REQUIRED.

4. One Coat Plaster: Gypsum plaster for single component application complying with ASTM C 587 (Uni-Kal BRAND Veneer Plaster).
5. One Coat Plaster: Extended set gypsum plaster for single component application complying with ASTM C 587 (X-KALibur BRAND Veneer Plaster).

**PART 3 EXECUTION**

3.01 INSTALLATION

- A. In accordance with the manufacturer's recommendations, National Gypsum Company "Gypsum Construction Guide," and the following standards:
  1. Gypsum plaster base and accessories in accordance with ASTM C 844.
  2. Gypsum veneer plaster in accordance with ASTM C 843.
- B. Tolerances: For flatness of surface, do not exceed 1/4" in 8' for bow or warp of surface and for plumb and level.