

**VENT-FREE
INFRARED
GAS WALL HEATER
MODEL CA30000**

**PROPANE
CL, CLF**

**NATURAL GAS
C, CF**



SignitePro[®]
Degrees Of Accuracy

**VENT-FREE
BLUE FLAME
GAS WALL HEATER
MODEL CA30000**

**PROPANE
BL, BLF**

**NATURAL GAS
B, BF**

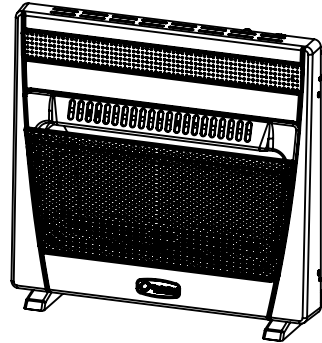
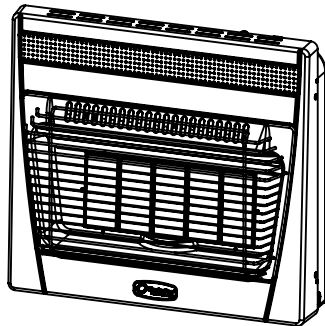

Intertek
C# 5014417

ANSI Z21.11.2-2016

Gas Fired Room Heaters
Volume II - Unvented Room Heaters

Refer to the Intertek Directory of Building Products
(<https://bpdirectory.intertek.com>) for detailed information

Manufactured by: SignitePro Inc., 71 Folsetter Dr., Paris, Ontario, N3L 0E2, Canada



WARNING: This appliance is equipped for natural or propane gas. Field conversion is not permitted



WARNING: IF THE INFORMATION IN THE MANUAL IS NOT FOLLOWED EXACTLY, A FIRE OR EXPLOSION MAY RESULT CAUSING PROPERTY DAMAGE, PERSONAL INJURY OR LOSS OF LIFE.

- Do not store or use gasoline or other flammable vapors and liquids in vicinity of this and or other appliances

WHAT TO DO IF YOU SMELL GAS:

- Do not try to light the appliance
- Do not touch any electrical switches, do not use any phone inside your building
- Immediately call your gas provider from a neighbour's phone
- Follow the gas providers instructions
- If you can not reach your gas provider, contact the fire department
- Installation and service of this appliance must be performed by a qualified installer, service agent or the gas provider

This is an unvented gas-fired heater. It uses air (oxygen) from the room in which it is installed. Provisions for adequate combustion and ventilation air must be provided. Refer to "Air For Combustion and Ventilation" section on page 7 of this manual.

**INSTALLER: Leave this manual with the appliance
CONSUMER: Retain this manual for future reference**

This appliance may be installed in aftermarket, permanently located, manufactured (mobile) home, where not prohibited by local codes. This appliance is only for use with the type of gas indicated on the rating plate. This appliance is not convertible for use with other gases.



Application Questions? Missing Parts? Before returning appliance to retailer, please contact customer service department between 9am EST - 3pm EST @ (519) - 442-4848 email us at: service@signitepro.com

TABLE OF CONTENTS

PRODUCT SPECIFICATIONS - 2
 IMPORTANT SAFETY INFORMATION - 3
 PRODUCT FEATURES - 5
 PREPARING FOR INSTALLATION - 6
 INSTALLATION - 10
 OPERATION - 19
 CARE AND MAINTENANCE - 24
 TROUBLESHOOTING - 25
 REPLACEMENT PARTS LIST - 28
 WARRANTY - 29



WARNING: Read the installation & operating manual completely before using this appliance. **IMPORTANT:** Read all instructions and warnings carefully before starting installation. Failure to follow these instructions may result in possible injury to persons or a fire hazard and will void warranty.

PRODUCT SPECIFICATIONS

SERIES	CA30000B	CA30000BF	CA30000BL	CA30000BLF	CA30000C	CA30000CF	CA30000CL	C30000CLF
Maximum BTU/hr	30,000	30,000	30,000	30,000	30,000	30,000	30,000	30,000
Minimum BTU/hr	15,000	15,000	15,000	15,000	---	---	---	---
Fuel Type	Natural Gas	Natural Gas	Propane	Propane	Natural Gas	Natural Gas	Propane	Propane
Ignition	Electronic Push Button	Electronic Push Button	Electronic Push Button	Electronic Push Button	Electronic Push Button	Electronic Push Button	Electronic Push Button	Electronic Push Button
INLET GAS PRESSURE								
Manifold Pressure	5 in W.C	5 in W.C	10 in W.C	10 in W.C	5 in W.C	5 in W.C	10 in W.C	10 in W.C
Maximum Pressure	9 in W.C	9 in W.C	14 in W.C	14 in W.C	9 in W.C	9 in W.C	14 in W.C	14 in W.C
*Minimum (*For purposes of input adjustment)	7 in W.C	7 in W.C	11 in W.C	11 in W.C	7 in W.C	7 in W.C	11 in W.C	11 in W.C
Dimensions (in.) (H x W x D) (Height includes legs)								
Dimensions (in.) (H x W x D) (Height includes legs)	25.4 x 26.8 x 7.5	25.4 x 26.8 x 7.5	25.4 x 26.8 x 7.5	25.4 x 26.8 x 7.5	25.4 x 26.8 x 7.5	25.4 x 26.8 x 7.5	25.4 x 26.8 x 7.5	25.4 x 26.8 x 7.5
Fan Ratings	---	110-120V 60Hz 23W 1400rpm	---	110-120V 60Hz 23W 1400rpm	---	110-120V 60Hz 23W 1400rpm	---	110-120V 60Hz 23W 1400rpm

IMPORTANT SAFETY INFORMATION

IMPORTANT: Read this owners manual carefully and completely before trying to assemble, operate, or service this heater. Improper use of this heater can cause serious injury or death from burns, fire, explosion, electrical shock and carbon monoxide poisoning.



WARNING: Any change to this heater or its controls can be dangerous.

Improper adjustment, alteration, service, maintenance, or installation of this heater or its controls can cause death or serious injury.

Read and follow instructions and precautions in User's Information Manual provided with this heater.

Installation and repair should be done by a qualified service person. The appliance should be inspected before use and at least annually by a professional service person. More frequent cleaning may be required due to excessive lint from carpeting, bedding material, etc. It is imperative that control compartments, burners and circulating air passageways of the appliance be kept clean.



WARNING: Carefully supervise young children when they are in the room with the heater.



WARNING: Heater becomes very hot when operating. Children and adults should be alert to the hazard of high surface temperatures and should stay away to avoid burns or clothing ignition. Heater will remain hot for a time after shutoff. Allow surfaces to cool before touching.



WARNING: Make sure any panel, safety screen or guard removed for servicing an appliance is replaced prior to operating the heater



WARNING: Keep the appliance area clear and free from combustible materials, gasoline, and other flammable vapors and liquids



WARNING: Do not place clothing or other flammable material on or near the appliance. Never place any objects on the heater.



WARNING: Due to high temperatures, locate this appliance out of traffic and away from furniture and draperies.

This appliance is intended for supplemental heating purposes only.

CARBON MONOXIDE POISONING: Early signs of carbon monoxide poisoning resemble the flu with headaches, dizziness or nausea. If you have these signs, the heater may not be working properly. Get fresh air immediately! Have the heater serviced. Some people are more affected by carbon monoxide than others. These include women, people with heart or lung disease, people who are anemic, those under the influence of alcohol, and those living in high altitudes.

NATURAL AND PROPANE (LP) GAS: Natural and Propane (LP) gases are odorless. An odor-making agent is added to the gas. The odor helps you detect gas leaks. However, the odor added to the gas can fade. Gas may be present even if no odor exists. Make certain you read and understand all warnings. Keep this manual for reference. It is your guide to operating this heater safely.

IMPORTANT SAFETY INFORMATION



WARNING:

If the heater is being installed in a residential garage, it must be secured firmly to the wall, a minimum of 18 inches (457 mm) above the floor. The heater must be located so that it is protected against any possibility of damage by a moving vehicle etc.

Raising the heater will reduce, BUT NOT eliminate the possibility of lighting the vapor of any flammable liquids which may be improperly stored or accidentally spilled. If the smell of gasoline is present, do not operate this heater until the area has been properly ventilated.





WARNING: Do not use any accessories not approved for use with this heater

CALIFORNIA PROPOSITION 65:

Fuels used in gas or oil fired appliances and the products of combustion of such fuels contain chemicals known to the state of California to cause cancer, birth defects or other reproductive harm. This product contains chemicals, including lead and compounds, known to the state of California to cause cancer, birth defects or other reproductive harm. Wash hands after handling.

1. Do not place Propane/LP supply tank(s) inside any structure. Place Propane/LP supply tank(s) outdoors.
2. This heater cannot be installed in a bedroom. These units are not approved for bathroom use.
3. This heater needs fresh air ventilation to run properly. This heater has an Oxygen Depletion Sensing (ODS) safety shutoff system. The ODS shuts down the heater if not enough fresh air is available. See "Air for Combustion and Ventilation" on page 7. If heater keeps shutting off, see "Care and Maintenance" on page 24.
4. Keep all air openings in front, top and bottom of heater free of objects and debris to ensure adequate air for proper combustion
5. If heater shuts off, do not relight until you have provided fresh, outside air. If heater keeps shutting off, have it serviced.
6. Do not run heater:
 - Where flammable liquids or vapors are used or stored
 - Under dusty conditions
7. Before using furniture polish, wax, carpet cleaner, or similar products, turn heater and pilot off. If heated, the vapors from these products may create a white powder residue within burner box or on adjacent walls or furniture.
8. Do not use heater if any part has been under water. Immediately call a qualified service technician to inspect the room heater and to replace any part of the control system and any gas control which has been under water.
9. Turn off and let cool before servicing. Only a qualified service person should service and repair heater.
10. To prevent performance problems, do not use propane/LP fuel tank of less than 100 lbs. capacity.

PRODUCT FEATURES

11.  **WARNING:** Do not allow fans to blow directly into the heater. Avoid any drafts that alter the burner flame patterns.
12.  **WARNING:** Do not operate heater if the tempered glass panel is not secured, broken, or missing. Only replace with tempered glass panel with parts and/or components provided by Factory.
13. **SAVE THESE INSTRUCTIONS.**

SAFETY PILOT

This heater has a pilot with an Oxygen Depletion Sensing (ODS) safety shutoff system. The ODS/pilot shuts off the heater if there is not enough fresh air and cuts off main burner gas in the event of flame out.

LEG KIT

2 support legs and 4 support leg screws are included for floor mounting the heater. For further information see page 6.

NOTE: This is an optional accessory and is not required for operation of the heater.

ELECTRONIC PUSH BUTTON IGNITION SYSTEM

This heater is equipped with an electronic push button ignition system. This system requires one AAA battery (provided).

THERMOSTAT HEAT CONTROL

The control automatically cycles the burner on and off to maintain a desired room temperature. For further information see page 20.

State of Massachusetts: The installation must be made by a licensed plumber or gas fitter in the Commonwealth of Massachusetts. Sellers of unvented propane or natural gas-fired supplemental room heaters shall provide to each purchaser a copy of 527 CMR 30 upon sale of the unit.

In the State of Massachusetts, unvented propane or natural gas-fired space heaters shall be prohibited in bedrooms and bathrooms.

In the State of Massachusetts the gas cock must be a T-handle type. The State of Massachusetts requires that a flexible appliance connector cannot exceed three feet in length.

LOCAL CODES

Install and use heater with care. The installation must conform with local codes or, in the absence of local codes, with the latest edition of The Nation Fuel Gas Code, ANSI Z223.1/NFPA 54

Available from:

American National Standard Institute, Inc.
1430 Broadway
New York, NY 10018

National Fire Protection Association, Inc.
1 Batterymarch Park
Quincy, MA, 02269-91101

This heater is designed for vent-free operation. State and local codes in some areas prohibit, restrict and/or have special requirements for vent-free heaters.

PREPARING FOR INSTALLATION

Before beginning assembly or operation of the product, make sure all parts are present. Compare parts with package contents list. If any part is missing or damaged, do not attempt to assemble, install or operate the product. Contact customer service for replacement parts.

UNPACKING

1. Remove heater from carton.
2. Remove all protective packaging applied to heater for shipping.
3. Verify all contents are present.
4. If legs purchased separately, accessory bag contains:
Mounting Bracket × 1, Wood Screw (4x50) × 4, Screw (4.8x25) × 2, AAA Battery × 1, Rawl Plugs × 4, Spacer × 2
5. Leg mount kit contains: Screw(3.9×13) × 4, Support Leg × 2
6. Check heater for any shipping damage. If heater is damaged, inform dealer immediately

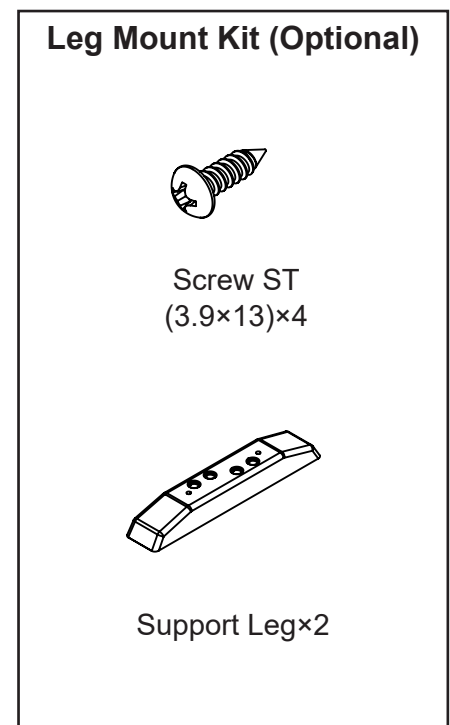
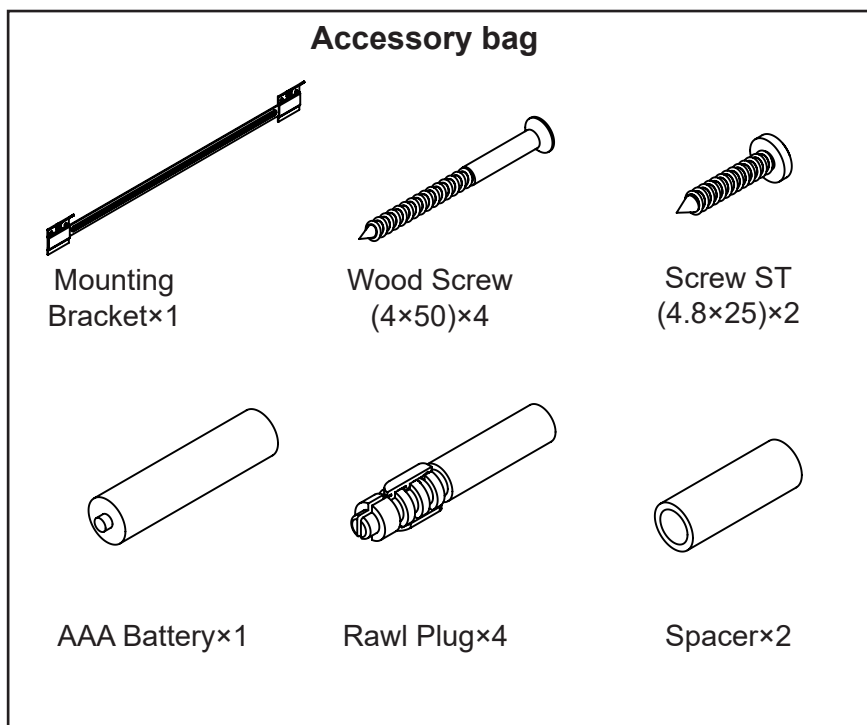

WATER VAPOR: A BY-PRODUCT OF UNVENTED ROOM HEATERS

Water vapor is a by-product of gas combustion. An unvented room heater produces approximately one (1) ounce (30 mL) of water for every 1,000 BTU (.3 Kw) of gas input per hour. An unvented room heater is intended as a supplemental heater rather than a primary heat source. In most supplemental heat applications, the water vapor does not create a problem.

In most applications, the water vapor enhances the low humidity atmosphere experienced during cold weather. The following steps will help ensure that water vapor does not become a problem:

1. Be sure the heater is the proper size for the application, including adequate combustion air and circulation air.
2. If there is high humidity, a dehumidifier may be used to help lower the water vapor content of the air.
3. Do not use an unvented room heater as the primary heat source.

PREPARING FOR INSTALLATION

AIR FOR COMBUSTION AND VENTILATION

 **CAUTION:** This heater shall not be installed in a room or space unless the required volume of indoor combustion air is provided by the method described in the National Fuel Gas Code, ANSI Z223.1/NFPA 54, the International Fuel Gas Code, or applicable local codes.

PRODUCING ADEQUATE VENTILATION

All spaces in homes fall into one of the three following ventilation classifications:

1. Unusually Tight Construction
2. Unconfined Space
3. Confined Space

The information on pages 8 through 10 will help you classify your space and provide adequate ventilation.

CONFINED AND UNCONFINED SPACE

A confined space is a space whose volume is less than 50 cu. ft. per 1,000 BTU/hr (4.8 m³ per kw) of the aggregate input rating of all appliances installed in that space and an unconfined space as a space whose volume is not less than 50 cu. ft. per 1,000 BTU/hr (4.8 m³ per kw) of the aggregate input rating of all appliances installed in that space. Rooms connecting directly with the space in which the appliances are installed*, through openings not furnished with doors, are considered a part of the unconfined space. This heater shall not be installed in a confined space or unusually tight construction unless provisions are provided for adequate combustion and ventilation air.

* Adjoining rooms are connecting only if there are doorless passageways or ventilation grills between them.

UNUSUALLY TIGHT CONSTRUCTION

The air that leaks around doors and windows may provide enough fresh air for combustion and ventilation. However, in buildings of unusually tight construction, you must provide additional fresh air. Unusually tight construction is defined as construction where:

- a) Walls and ceilings exposed to the outside atmosphere have a continuous water vapor retarder with a rating of one perm (6×10^{-11} kg per pa-sec-m²) or less with openings gasketed or sealed
- b) Weather stripping has been added on windows that can be opened and on doors
- c) Caulking or sealants are applied to areas such as joints around window and door frames, between sole plates and floors, between wall-ceiling joints, between wall panels, at penetrations for plumbing, electrical, and gas lines, and at other openings.

If your home meets all of the three criteria above, you must provide additional fresh air. See "Ventilation Air From Outdoors" on page 9. If your home does not meet all of the three criteria above, proceed to "Determining Fresh-Air Flow For Heater Location".

PREPARING FOR INSTALLATION

DETERMINING FRESH-AIR FLOW FOR HEATER LOCATION

Determining if You Have a Confined or Unconfined Space

Use this worksheet to determine if you have a confined or unconfined space.

Space: Includes the room in which you will install heater plus any adjoining rooms with doorless passageways or ventilation grills between the rooms.

1. Determine the volume of the space Length x Width x Height = cu. ft. (volume of space)
2. If additional ventilation to adjoining rooms is supplied with grills or openings, add the volume of these rooms to the total volume of the space.
Divide the space volume by 50 cu. ft. to determine the maximum BTU/hr the space can support. _____ (volume of space) / 50 cu. ft.= (Maximum BTU/hr the space can support)
3. Add the BTU/hr of all fuel burning appliances in the space.

Vent-free heater	+	_____	BTU/hr
Gas water heater*	+	_____	BTU/hr
Gas furnace	+	_____	BTU/hr
Vented gas heater	+	_____	BTU/hr
Gas heater logs	+	_____	BTU/hr
Other gas appliances*	+	_____	BTU/hr
Total	=	_____	BTU/hr

*Do not include direct-vent gas appliances. Direct-vent draws combustion air from the outdoors and vents to the outdoors.

4. Compare the maximum BTU/hr the space can support with the actual amount of BTU/hr used.
_____ BTU/hr (maximum the space can support)
_____ BTU/hr (actual amount of BTU/hr used).

If the actual BTU/hr used is more than the maximum BTU/hr the space can support, you must provide additional fresh air. Your options are as follows:

- a) Rework worksheet, adding the space of an adjoining room. If the extra space provides an unconfined space, remove door to adjoining room or add ventilation grills between rooms. See "Ventilation Air From Inside Building" on page 9.
- b) Vent room directly to the outdoors. See "Ventilation Air From Outdoors" on page 9.
- c) Install a lower BTU/hr heater if lower BTU/hr size makes room unconfined. If the actual BTU/hr used is less than the maximum BTU/hr the space can support, the space is an unconfined space. You will need no additional fresh air ventilation.

PREPARING FOR INSTALLATION

VENTILATION AIR FROM INSIDE BUILDING

This fresh air would come from adjoining unconfined space. When ventilating to an adjoining unconfined space, you must provide two permanent openings: one within 12 in. of the wall connecting the two spaces (see options 1 and 2, Fig. 1). You can also remove door into adjoining room (see option 3, Fig. 1).

Follow the National Fuel Gas Code NFPA 54/ANS Z223.1: Air for Combustion and Ventilation for required size of ventilation grills or ducts.

VENTILATION AIR FROM OUTDOORS

Provide extra fresh air by using ventilation grills or ducts (see Fig. 2).

You must provide two permanent openings: one within 12 in. of the ceiling and one within 12 in. of the floor.

Connect these items directly to the outdoors or spaces open to the outdoors. These spaces include attics and crawl spaces. Follow the National Fuel Gas Code NFPA 54/ANS Z223.1: Air for Combustion and Ventilation for required size of ventilation grills or ducts.

IMPORTANT: Do not provide openings for inlet or outlet air into attic if attic has a thermostat controlled power vent. Heated air entering the attic will activate the power vent. Rework worksheet, adding the space of the adjoining unconfined space. The combined spaces must have enough fresh air to supply all appliances in both spaces.

Ventilation Grills Into adjoining Room Option 1

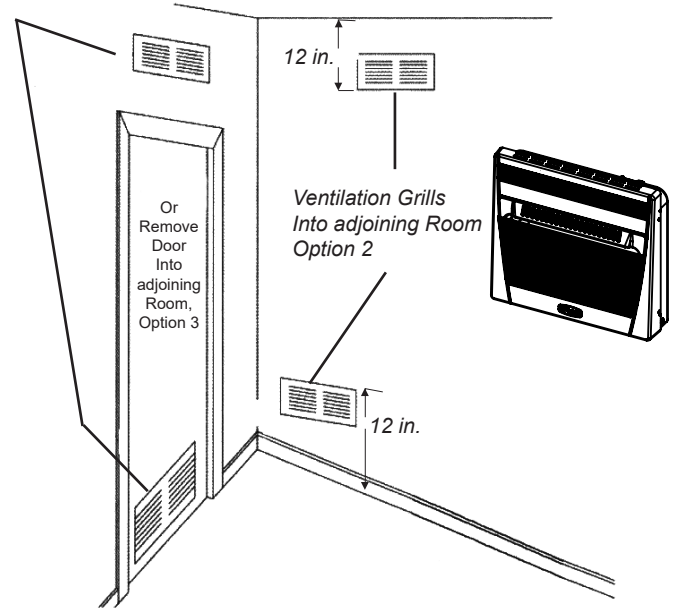

Fig. 1: Ventilation Air From Inside Building

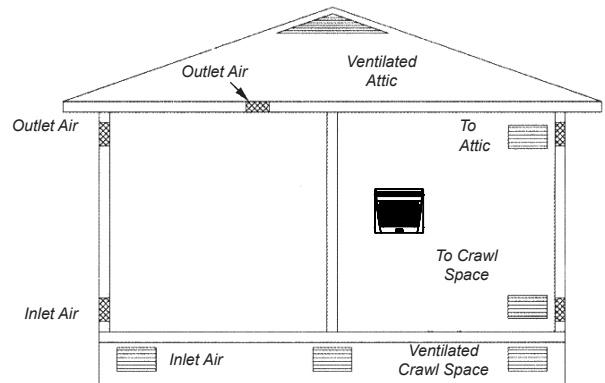

Fig. 2: Ventilation Air From Outdoors

INSTALLATION

NOTICE: This heater is intended for use as supplemental heat. Use this heater along with your primary heating system. Do not install this heater as your primary heat source. Do not install this heater in a bathroom or bedroom.

WARNING: A qualified technician must install heater. Follow all local codes.

WARNING: Maintain the minimum clearances. If possible, provide greater clearances from the floor, ceiling, and adjoining wall than required.

CAUTION: This heater creates warm air currents. These currents move heat to wall surfaces next to the heater. Installing the heater next to vinyl or cloth wall coverings or operating the heater where impurities (such as tobacco smoke, candles, cleaning fluids, oil or kerosene lamps, etc.) in the air exist, may cause walls to discolor.

CLEARANCES TO COMBUSTIBLES
Carefully follow the instructions below. This heater can be mounted on the wall or on the floor using the support legs provided separately.

WARNING: Maintain the minimum clearances shown (see Fig. 3A and 3B). If you can, provide greater clearances from floor, ceiling, and joining wall.

Fig. 3A: Mounting clearances as viewed from front of heater (inches) - Infrared

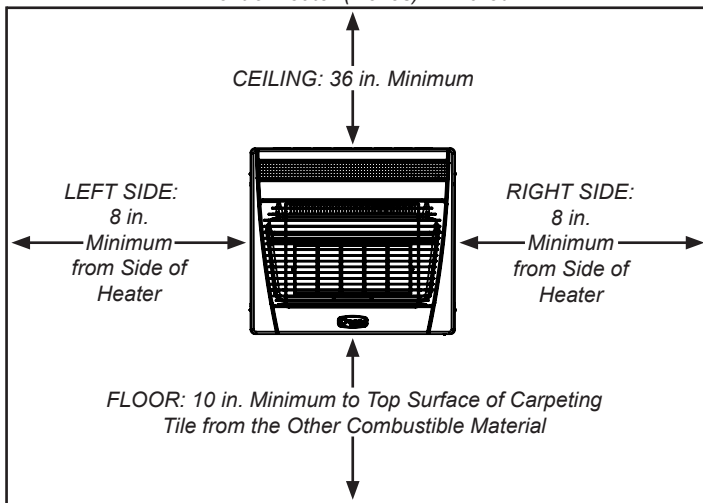
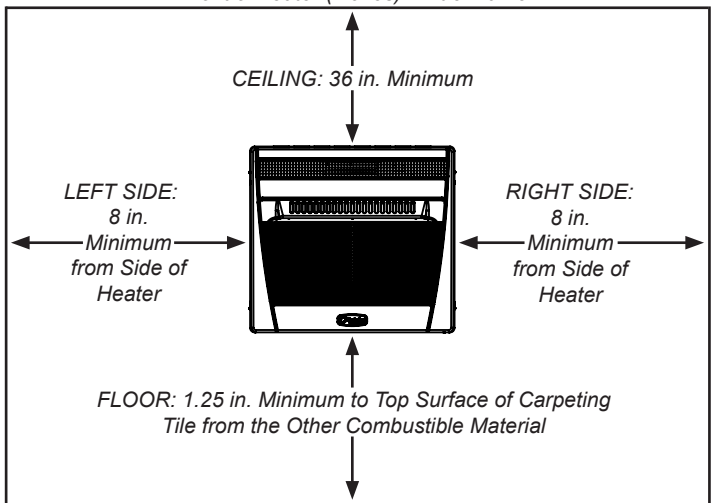

Fig. 3B: Mounting clearances as viewed from front of heater (inches) - Blue Flame



MINIMUM CLEARANCE TO COMBUSTIBLES					
Model	*Left/Right	Top	Bottom	Front	Rear
Blue Flame	8 in.	36 in.	1.25 in.	36 in.	0 in. to Spacer
Infrared	8 in.	36 in.	10 in.	36 in.	0 in. to Spacer
Top clearance is from top heater to ceiling, wood shelf or other combustible material					
Bottom clearance is from bottom of heater to surface of carpet, tile or other combustible material.					

*A second side wall must be at least 18 in. away from the other side of the heater.
Always maintain a minimum of 36 in. clearance from furniture and draperies.
For installation in residential garages please refer to page 4.

INSTALLATION

INSTALLING IGNITOR BATTERY

NOTE: Battery is included.

1. Unscrew ignitor cap and insert included battery negative (flat) side down (see Fig. 4).
2. Replace ignitor cap.
3. Be sure to observe proper polarity (+/-) when installing or replacing the battery. Damage due to improper battery installation may void the warranty on the product.
4. Install/replace the battery according to the type and quantity stated in table below.
5. Remove battery when depleted.
6. For long periods of non-operation, remove the battery from all components for safety.

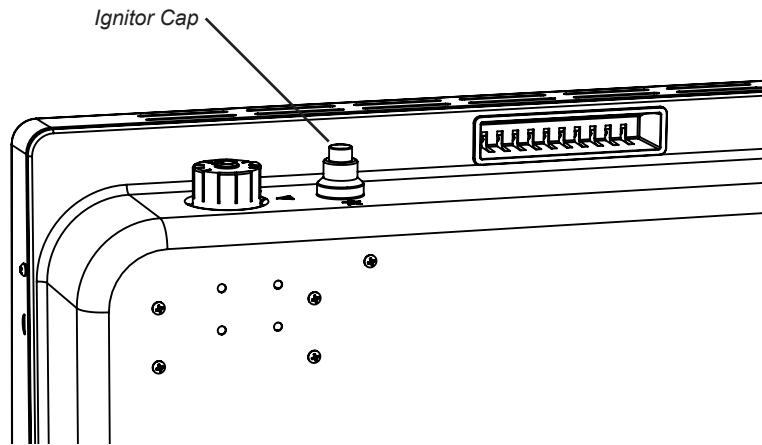

Fig 4: Installing Ignitor Battery

WARNING: Do not use rechargeable silver oxide cell batteries

Component	Type of Battery	Battery Qty.
Ignitor	AAA	1

DO NOT dispose of batteries in fire. Improper disposal may cause batteries to leak or explode.

PREINSTALLED FAN (OPTIONAL)

WARNING: This appliance is equipped with a three-prong grounding plug for your protection against shock hazards and should be plugged directly into a properly grounded three-prong receptacle.

NOTE: If any of the original wire as supplied with the appliance must be replaced, it must be replaced with a wire of at least an equal temperature rating.

Label all wires prior to disconnection when servicing controls. Wiring errors can cause improper and dangerous operation.

Verify proper operation after servicing.

Fig .5: Grounded Three-Prong Receptacle

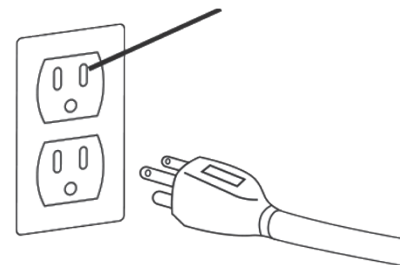

INSTALLATION

ELECTRIC WIRING

The appliance, when installed, must be electrically grounded in accordance with the National Electrical Code, ANSI/NFPA 70, if an external electrical source is utilized. This appliance is equipped with a three prong grounding plug for protection against shock hazards and should be plugged directly into a properly grounded three-prong receptacle. Do not cut or remove the grounding prong from this plug. For an ungrounded receptacle, an adapter, which has two prongs and a wire for grounding, can be purchased, plugged into the ungrounded receptacle and its wire connected to the receptacle mounting screw.

ACCESSING FAN

1. Turn off gas supply to appliance
2. Remove appliance from mounted position (if applicable)
3. Remove screws connecting front heater cover to unit. Rest front heater cover assembly close to appliance (see Fig. 6).
4. Note AC cord connections before disconnecting cord from appliance. Disconnect identified AC cord connections and set rear heater cover aside
5. Remove screws securing fan to heater (see Fig. 7).

The preinstalled fan is a factory installed option. There are no provisions for installing the optional fan into an appliance that did not come equipped with it from the factory.

The preinstalled fan is sealed from the factory and does not require any maintenance.

Fig. 6: Removing Front Heater Cover

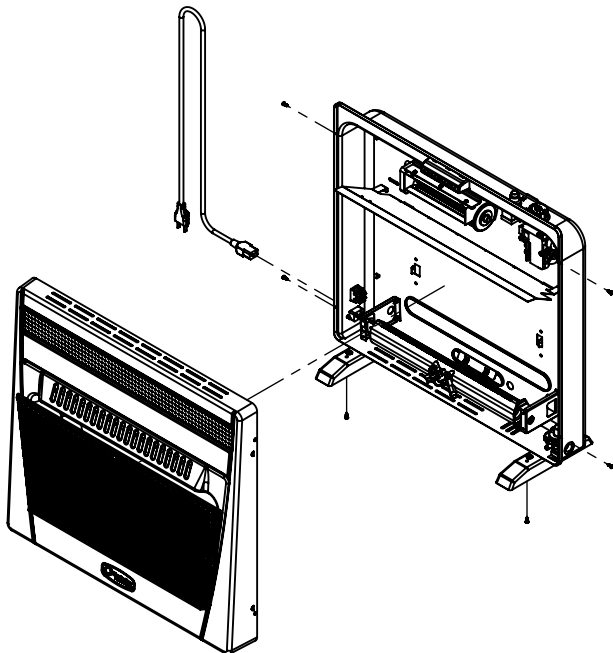
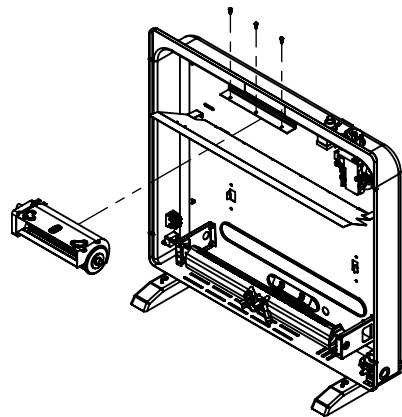
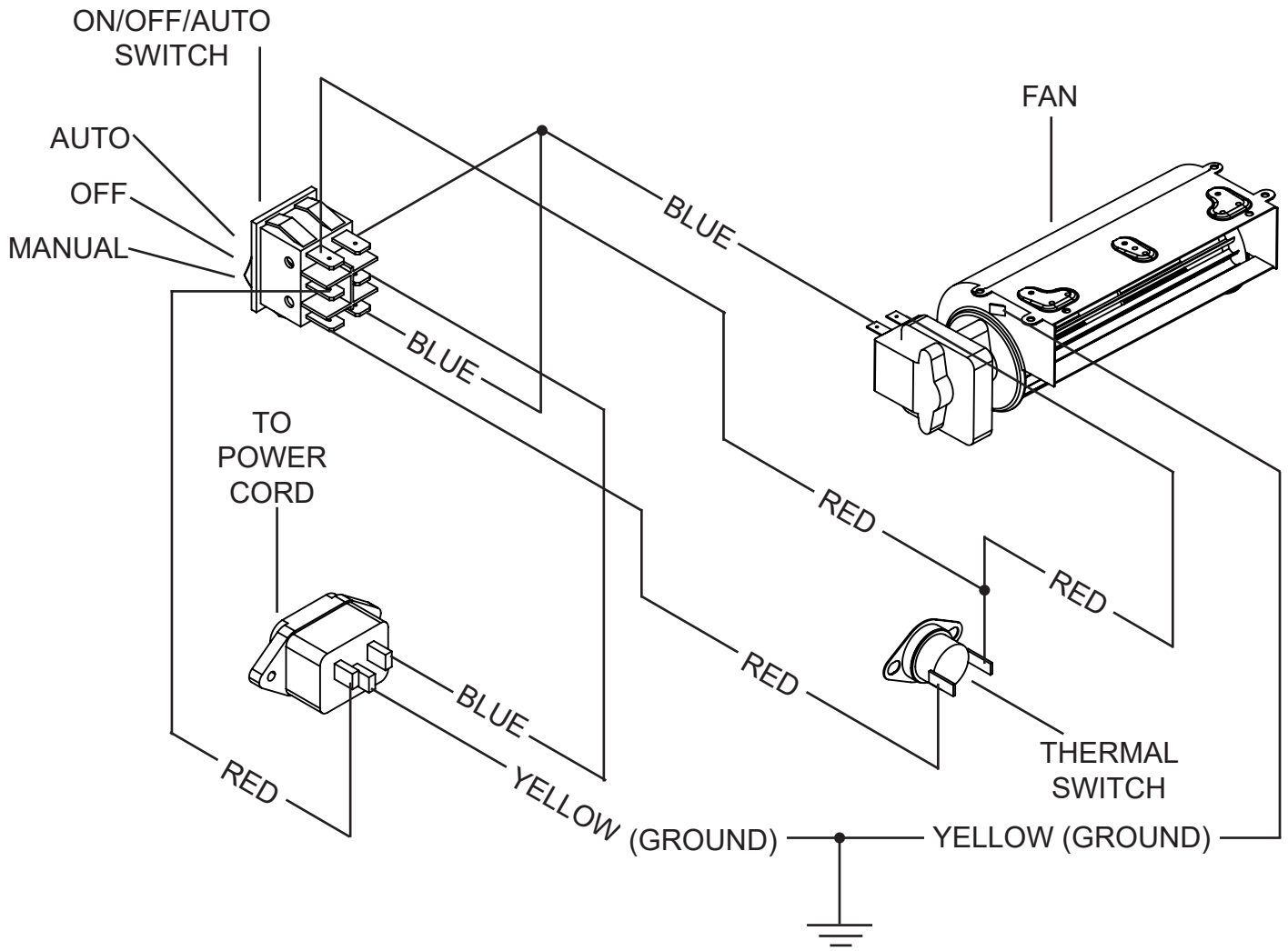

Fig. 7: Removing Fan



INSTALLATION

WIRING ASSEMBLY DIAGRAM



ELECTRICAL SCHEMATIC

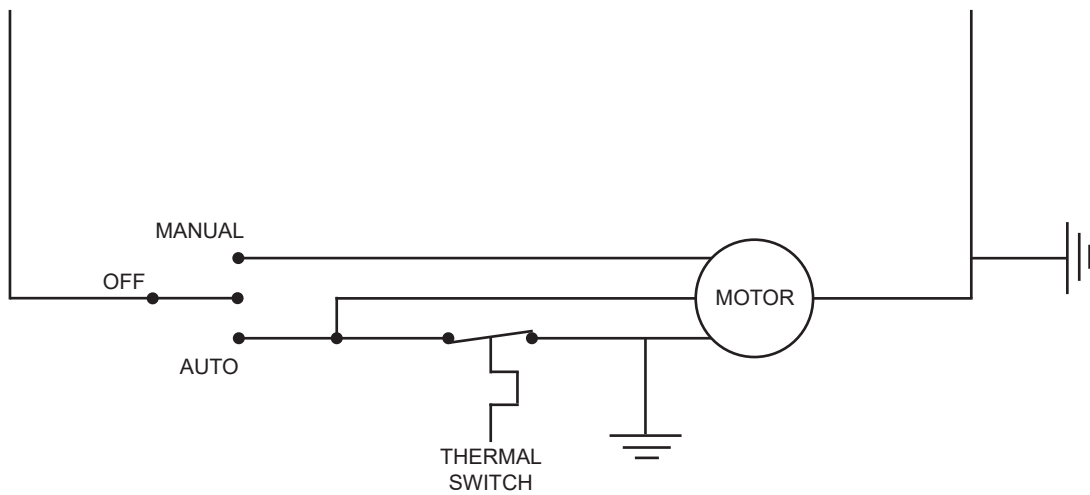

INSTALLATION

LOCATING HEATER

This heater is designed to be mounted on a wall or on a floor, using the Support Legs included with select models. For convenience and efficiency, install heater: Where there is easy access for operation, inspection, and service. In the coldest part of room. A minimum of 36" away from furniture and draperies.

FLOOR MOUNTING

NOTE: This is an optional accessory and is not required for operation of the heater.

Cannot be done in bedroom or bathroom

Before installing Support Legs to heater base, please make sure you have the following items:

- (2) Support Legs
- (4) Support Leg Screws (ST 3.9×13)

Set down a blanket onto the table where the heater will be placed for leg installation to prevent scratching of the table and/or the heater.

Set back of heater on table with the bottom of heater extending outside the table edge.

Fasten Support Legs to heater using Support Leg Screws (see Fig. 8).

Note: If the heater is to be installed directly on carpeting, tile or other combustible material, other than wood flooring, the appliance shall be installed on a metal or wood panel extending the full width and depth of the appliance. Once positioned, secure heater to the floor using Support Leg Screws (ST 3.9×13) and mounting holes found on heater Support Legs (see Fig. 8).

! WARNING: Failure to position the parts in accordance with these diagrams or failure to use only parts specifically approved with this heater may result in property damage or personal injury.

Fig. 8: Securing Support Leg

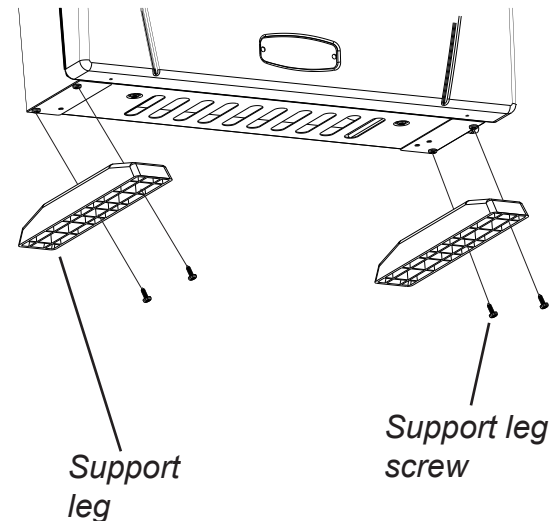

INSTALLATION

WALL MOUNTING

Wall mount procedure

WARNING



ELECTRICAL, PLUMBING OR GAS LINES MAYBE IN WALL.

Before cutting, drilling or hammering verify their location. If needed, contact your electrician, plumber or service person

Mark Screw Locations on Wall as per Figure 9 below:

IMPORTANT: If wall mounting an infrared unit, the distance from the floor to bottom of the appliance must be at least 10 in. high

Fig. 9:

- Mark holes at locations shown in Fig. 9 using a square
- Check that holes are straight and level before drilling by using a level

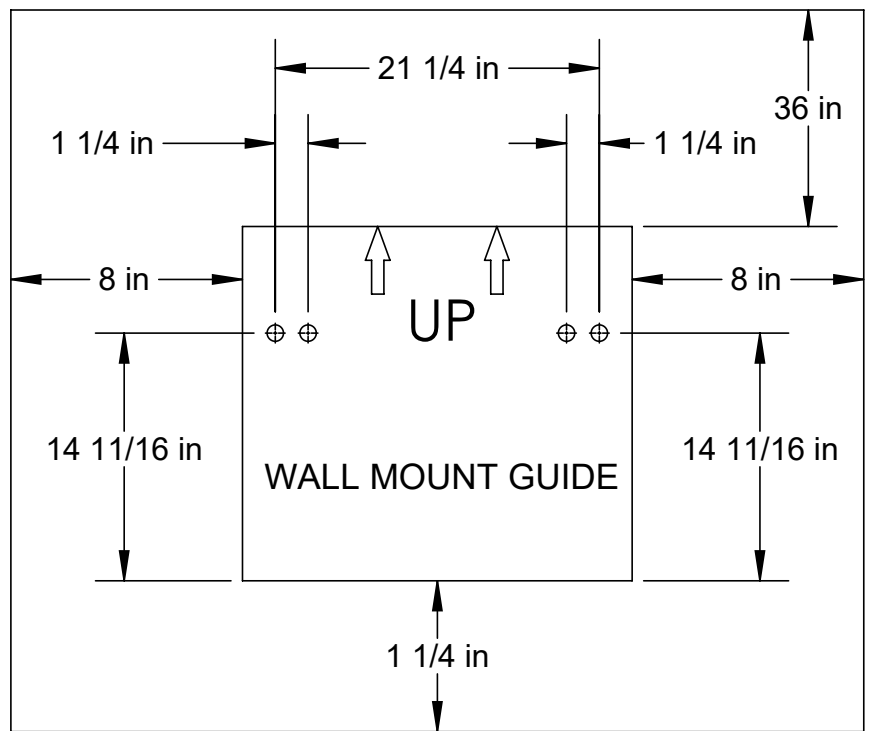
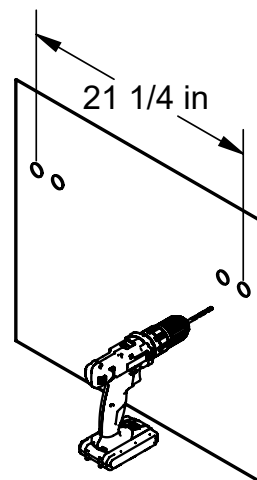

Fig. 9: Wall mounting dimensions

Fig. 10:

- Drill holes at marked locations using:
- A 9/64 in. drill bit for wall stud mounting
- A 5/16 in. drill bit if using expansion brackets for hollow wall mounting. Drill 5/16 in. holes at least 1 in. deep



INSTALLATION



WARNING: Failure to properly install all wall hanging parts may result in property damage, personal injury, or even death

Fig. 11:

- Insert Rawl Plugs into wall after drilling holes.
- Screw brackets into Rawl Plugs ensuring that brackets are completely in the wall

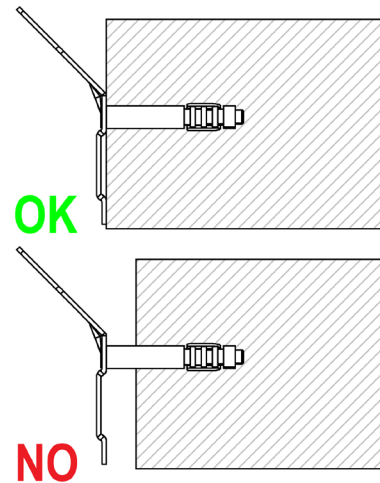

Fig. 12:

- Locate spacer mounting holes on lower left/right of appliance
- Screw 2 spacers into appliance using 2 wall hanging spacer screws (4.8 x 25)
- Check that the spacers are secure before mounting appliance

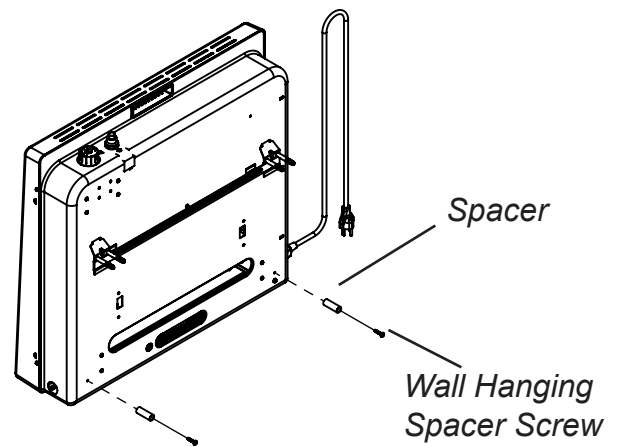
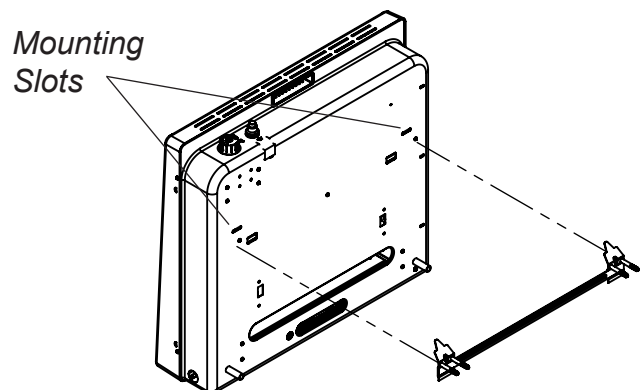

Fig. 13:

- Locate Mounting Slots on upper left/right of appliance
- Carefully lift appliance onto Wall Bracket
- Check that appliance is secure in place after wall mounting



INSTALLATION

CONNECTING TO GAS SUPPLY



WARNING: A qualified service technician must connect the heater to the gas supply. Follow all local codes.



IMPORTANT: This appliance requires a 3/8-inch NPT (National Pipe Thread) inlet connection to the pressure regulator. Never connect the heater to private (non-utility) gas wells, commonly known as wellhead gas.



WARNING: Do not overtighten gas connections.



CAUTION: Use only new, black iron or steel pipe. Internally tinned copper tubing may be used in certain areas. Check your local codes. Use pipe of 1/2-in. diameter or greater to allow proper gas volume to heater. If pipe is too small, undue loss of pressure will occur.



CAUTION: Check your gas line pressure before connecting the heater to a gas line. Gas line pressure must be a minimum 7" WC for NG & 11" WC for LP with a max pressure of 9" WC for NG & 14" WC for LP. If gas line pressure is higher, the unit will not work and heater regulator damage could occur.



CAUTION: Never connect the heater directly to a LP supply. This heater requires an external regulator (not supplied). Install the external regulator between the heater and gas supply.



CAUTION: Avoid damage to regulator. Hold the gas regulator with a wrench when connecting into gas piping and/or fittings.



CAUTION: Use pipe joint sealant that is resistant to gas (Propane or Natural Gas).

Typical Inlet Pipe Diameters

Use 3/8-inch black iron pipe or greater. Installation must include an equipment shutoff valve, union, and plugged 1/8-inch NPT tap. Locate NPT tap within reach for test gauge hook up. NPT tap must be upstream from the heater (see Fig. 14).



IMPORTANT: Install an equipment shutoff valve in an accessible location. The equipment shutoff valve is for turning on or shutting off the gas to the appliance.

Apply pipe joint sealant lightly to male threads. This will prevent excess sealant from going into pipe. Excess sealant in pipe could result in clogged heater valves.

INSTALLATION

Install sediment trap in supply line as shown (see Fig. 14). Place sediment trap where it is within reach for cleaning. Place sediment trap where trapped matter is not likely to freeze. A sediment trap traps moisture and contaminants. This keeps them from going into heater controls. If sediment trap is not installed or is installed wrong, the heater may not run properly.

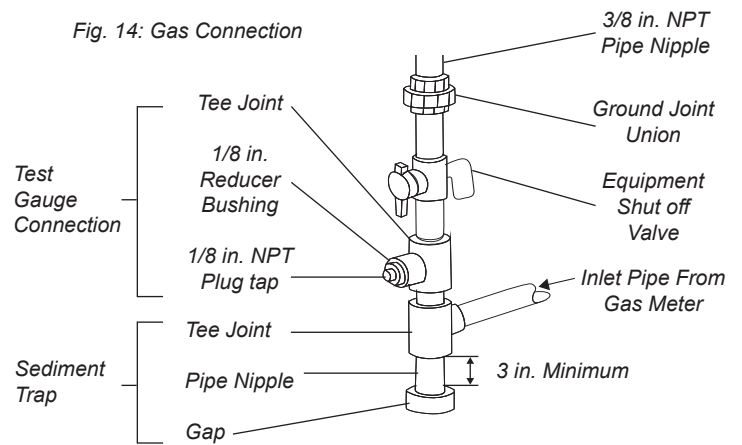

CHECKING GAS CONNECTIONS

WARNING: Test all gas piping and connections for leaks after installing or servicing. Correct all leaks immediately.

WARNING: Never use an open flame to check for a leak. Apply a 50/50 mixture of liquid soap and water to all joints. If bubbles form, there may be a leak. Correct all leaks immediately.

PRESSURE TESTING GAS SUPPLY PIPING SYSTEM

Test Pressures In Excess Of 1/2 PSIG (3.5 kPa)

The appliance and the appliance main gas valve must be disconnected from the gas supply piping system during any pressure testing of that system at test pressures in excess of 1/2 psi (3.5 kPa).

Pressure Testing Gas Supply Equal To or less than 1/2 PSIG (3.5 kPa)

The appliance must be isolated from the gas supply piping system by closing its equipment shutoff valve during any pressure testing of the gas supply piping system at test pressures equal to or less than 1/2 psi (3.5 kPa).

Leak Testing Heater Gas Internal Connections

1. Open equipment shutoff valve (see Fig. 15).
2. Make sure control knob of the heater is in the OFF position.
3. Open gas supply tank valve (LP systems).
4. Check all joints from equipment shutoff valve to control valve. Apply 50/50 mixture of liquid soap and water to gas joints. If bubbles form, there may be a leak.
5. Light heater (see "Lighting Instructions" on page 20). Check all other internal joints for leaks.
6. Turn off heater (see "To Turn Off Gas to Appliance" on page 21).

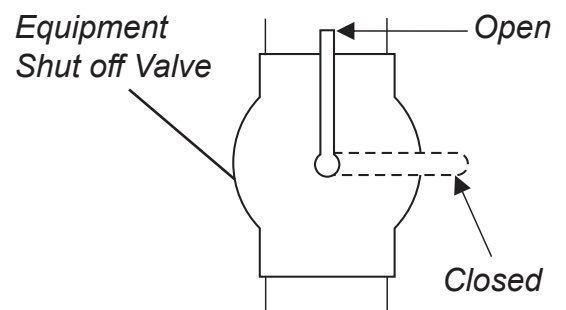

Fig. 15: Equipment Shutoff Valve

OPERATION

FOR YOUR SAFETY READ BEFORE LIGHTING



WARNING: If you do not follow these instructions exactly, a fire or explosion may result causing property damage, personal injury or loss of life

A. This appliance has a pilot which must be lit using the electronic ignitor. When lighting the pilot, follow these instructions exactly.

B. **BEFORE LIGHTING** smell all around the appliance area for gas. Be sure to smell next to the floor because some gas is heavier than air and will settle on the floor.

WHAT TO DO IF YOU SMELL GAS

- Do not try to light any appliance.
- Do not touch any electrical switch; do not use any phone in your building .
- Immediately call your gas supplier from a neighbor's phone. Follow the gas supplier's instructions.
- If you cannot reach your gas supplier, call the fire department.



C. Use only your hand to push in or turn the gas control knob. Never use tools. If the knob will not push in or turn by hand, don't try to repair it, call a qualified service technician. Forced or attempted repair may result in a fire or explosion.

D. Do not use this appliance if any part has been under water. Immediately call a qualified service technician to inspect the appliance and to replace any part of the control system and any gas control, which has been under water.

OPERATION

LIGHTING INSTRUCTIONS

THERMOSTAT GAS CONTROL

1. **STOP!** Read the safety information on the previous page.
2. Turn off all electric power to the appliance.
3. Turn control knob clockwise  to "OFF" position (see Fig. 16).
4. Wait (5) minutes to clear out any gas. Then smell for gas, including near the floor. If you smell gas, **STOP!** Follow "B" in the safety information above. If you don't smell gas, go to the next step.
5. Turn knob counterclockwise  to the "PILOT" position. (see Fig. 17). Depress control knob.
6. With control knob depressed, push down on the ignitor button until the pilot lights. The pilot is visible centered below the burner, behind the front grill (see Fig. 18).

- Do not attempt to light the pilot by hand

7. Keep control knob depressed for (30) seconds after pilot lights. Release control knob.

- If the control knob does not pop up when released, stop and immediately call your service technician or gas supplier.
- If pilot goes out repeat steps 3 through 7. Wait (1) minute before attempting to light pilot again. If after several tries the pilot still goes out, turn the gas control knob clockwise  to the "OFF" position and call your service technician or gas supplier.

8. Turn on all electric power to the appliance.
9. Turn control knob counterclockwise  to desired setting.

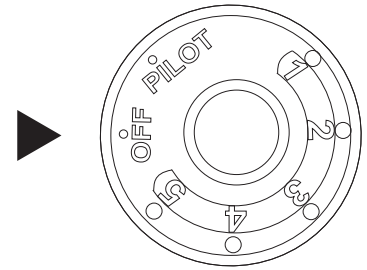

Fig. 16

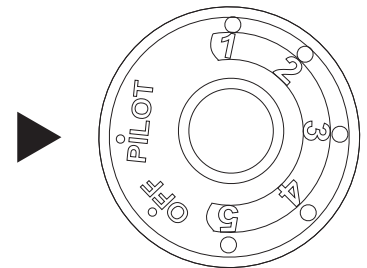

Fig. 17

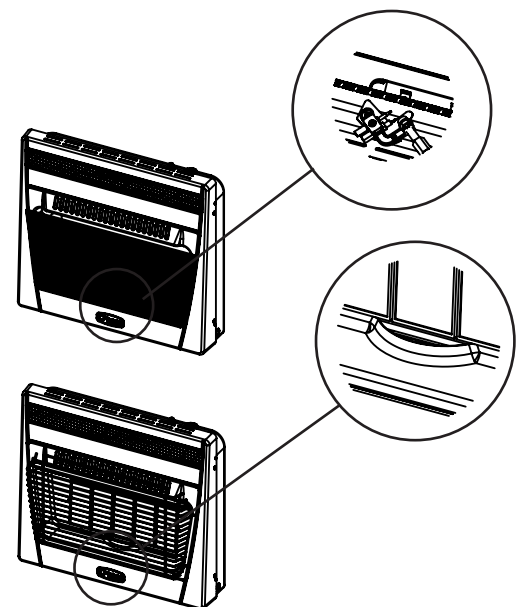



Fig. 18: Pilot Flame Location

OPERATION

TO TURN OFF GAS TO APPLIANCE

1. Turn off all electric power to the appliance.
2. Turn control knob clockwise  to the OFF position on the control knob.

THERMOSTATIC CONTROL OPERATION

The thermostat used on this heater senses the room temperature. At times the room may exceed the set temperature. If so, the burner will shut off. The burner will cycle back on when room temperature drops below the set temperature. The control knob can be set to any comfort level between “HIGH” (5) and “LOW”(1) (see Fig. 19).

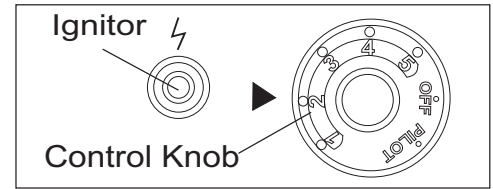

INSPECTING BURNERS

Check pilot flame pattern daily when in use and at least yearly by a qualified service agency.

PILOT FLAME PATTERN

Fig. 20 shows a correct pilot flame pattern. Fig. 21 shows an incorrect pilot flame pattern. The incorrect pilot flame is not touching the thermocouple. This will cause the thermocouple to cool, which shuts the heater off. If pilot flame pattern is incorrect: turn heater off (see “To Turn Off Gas to Appliance” on page 21) (see Troubleshooting pages 25 through 27.)

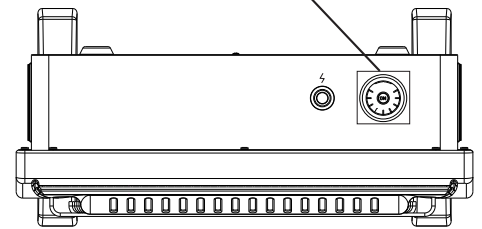

Fig. 19: Control knob position

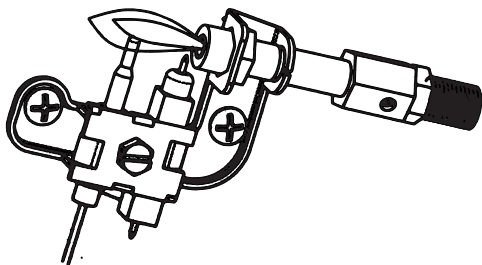

Fig. 20: Correct Pilot Flame Pattern

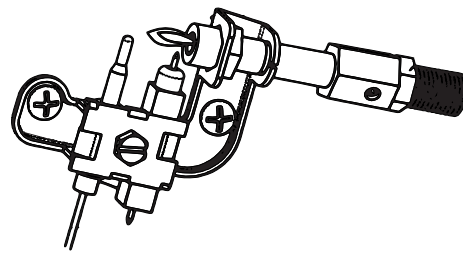



Fig. 21: Incorrect Pilot Flame Pattern

 **WARNING:** If yellow tipping occurs, your heater could produce increased levels of carbon monoxide. If burner flame shows yellow tipping, follow instructions under “Burner Flame Pattern” on page 21.

Notice: Do not mistake orange flames with yellow tipping. Dirt or other fine particles enter the heater and burn causing brief patches of orange flame.

BURNER FLAME PATTERN

Fig. 22 (blue flame) or Fig. 24 (infrared) shows a correct burner flame and Infrared flame pattern. Fig. 23 (blue flame) or Fig. 25 (infrared) shows an incorrect burner flame pattern with lifting, and excessive flame height. If burner flame is incorrect:

1. Turn heater off (see “To Turn Off Gas to Appliance” on page 21).
2. See “Troubleshooting” on pages 25 through 27.

OPERATION

Fig. 22: Correct/Normal Flame Pattern with short flames with Control Knob Set to High Flame (Blue Flame)

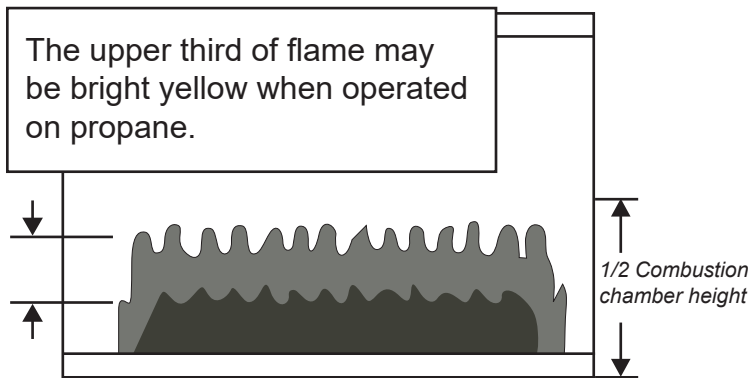

Fig. 23: Incorrect/Abnormal Flame Pattern with tall flames with Control Knob Set to High Flame (Blue Flame)

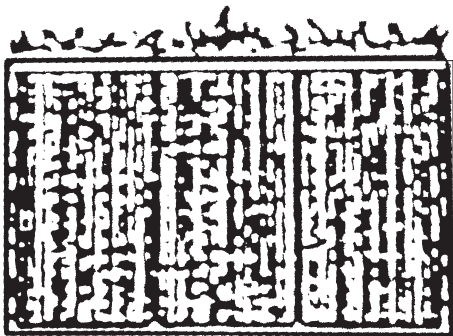
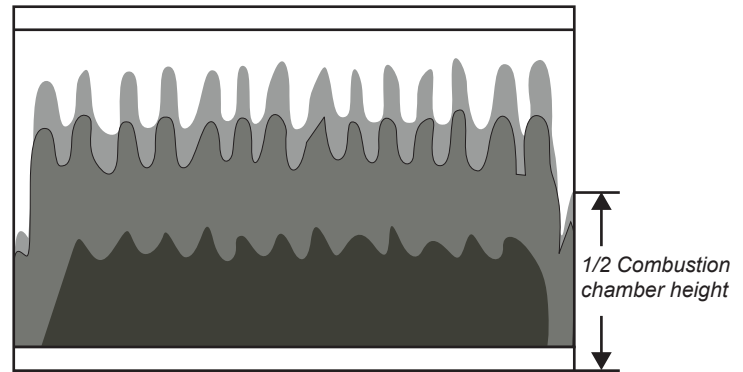

Fig. 24: Correct/Normal Flame Pattern with short flames with Control Knob Set to High Flame (Infrared Flame)

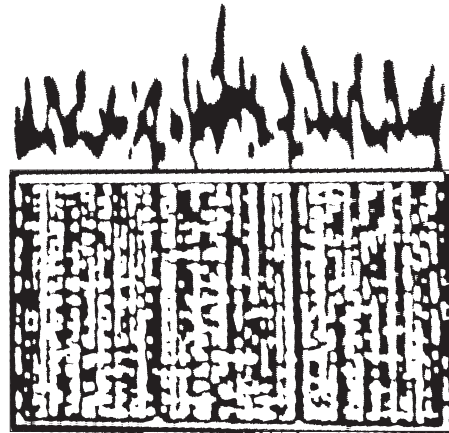

Fig. 25: Incorrect/Abnormal Flame Pattern with tall flames with Control Knob Set to High Flame (Infrared Flame)

NOTE: Ambient flame burners produce both a blue and yellow flame. An excessively high yellow colored flame may be caused by airborne dust, dander, pet hair, etc. Additionally, an excess amount of Mercaptane in the fuel can result in an orange or yellow colored flame.

When this heater is set for use on propane gas, the upper one third of the flame may be bright yellow. When this heater is set for use on natural gas, a slight yellow tipping of the flame may occur.

NOTE: Before servicing you will need to remove the front panel of the heater. There are 4 tapping screws, 2 on the left side and 2 on the right, securing the front panel to the heater (see Fig. 26). Always allow the unit to cool for at least thirty minutes before attempting to remove the front panel.

Fig. 26: Front Panel Removal

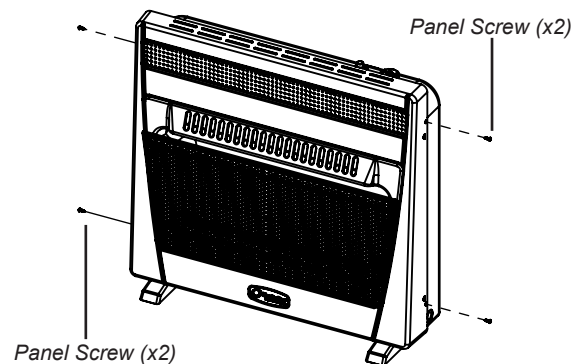

OPERATION

OPTIONAL FAN

For appliances equipped with the optional fan: the fan can operate in automatic mode or manual mode. Automatic mode will start or stop the fan based on temperature. Manual mode will run the fan continuously.

FOR AUTOMATIC FAN OPERATION

While the appliance is running, press the switch to the 'AUTO' position (see Fig. 27). The fan will automatically turn on or off based on the temperature.

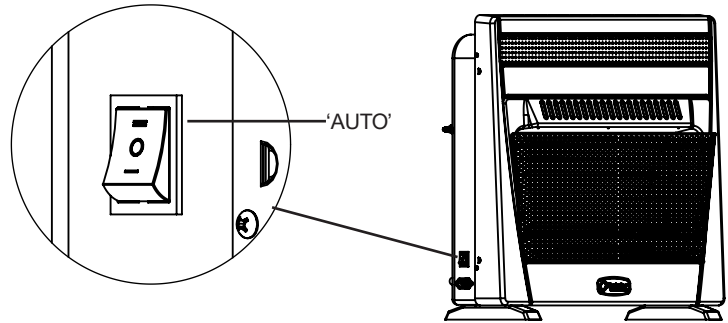

Fig. 27: 'AUTO' Switch Position

FOR MANUAL FAN OPERATION

While the appliance is running, press the switch to the 'MANUAL' position (see Fig. 28). The fan will run continuously until turned to 'AUTO' or 'OFF'.

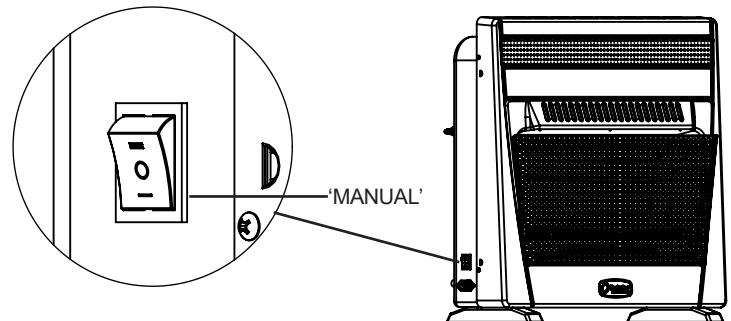

Fig. 28: 'MANUAL' Switch Position

TO TURN OFF FAN

While the appliance is running, press the switch to the 'OFF' position (see Fig. 29). The fan will not run until switched to 'AUTO' or 'MANUAL'. It is recommended to leave the fan in the 'OFF' position when not using the appliance.

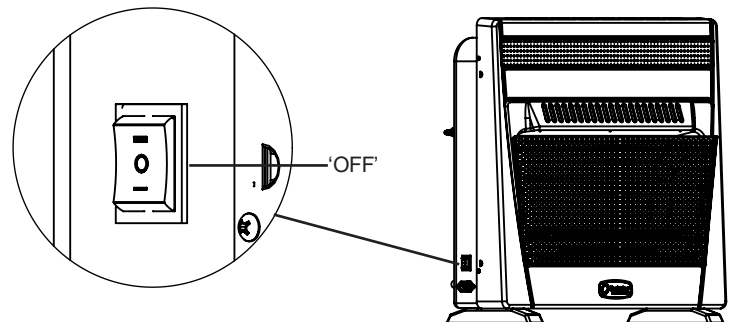



Fig. 29: 'OFF' Switch Position

CAUTION: Leaving the fan in the 'AUTO' or 'MANUAL' positions when the appliance is not running may lead to premature wear on the fan.

CARE AND MAINTENANCE

 **WARNING:** Turn off heater and let cool before servicing.

 **CAUTION:** You must keep the control areas, burner, and circulating air passageways of the heater clean. Inspect these areas of the heater before each use. Have the heater inspected yearly by a qualified service person. Heater may need more frequent cleaning due to excessive lint from carpeting, bedding material, pet hair, etc.

 **WARNING:** Failure to keep the primary air opening(s) of the burner(s) clean may result in sooting and property damage.

CLEANING ODS/PILOT AND BURNER

Use a vacuum cleaner, pressurized air, or a small, soft bristled brush to clean burner ports, orifice and primary burner. Look into the burner opening and ensure that it is clean.

CLEANING BURNER PILOT AIR INLET HOLE

We recommend that you clean the unit every three months or after 2,500 hours of operation. We also recommend that you keep the burner tube and pilot assembly clean and free of dust and dirt. To clean these parts, we recommend using compressed air no greater than 30 PSI. You can use a vacuum cleaner in the blow position. If using compressed air in a can, please follow the directions on the can. If you don't follow directions on the can, you could damage the pilot assembly.

 **CAUTION:** Never use a wire, needle, or similar object to clean ODS/pilot. This can damage ODS/ pilot unit.

1. Shut off the unit, including the pilot. Allow the unit to cool for at least thirty minutes.
2. Remove 4 screws - 2 screws on each side of the front panel.
3. Pull front panel forward.
4. Blow air through the ports/slots and holes in the burner. Also clean the pilot assembly. A yellow tip on the pilot flame indicates dust and dirt in the pilot assembly. There is a small pilot air inlet hole about two inches from where the pilot flame comes out of the pilot assembly (*see Fig. 21 & 22 on page 21*). With the unit off, lightly blow air through the air inlet hole. You may blow through a drinking straw if air is not available.
5. Replace front panel when completed, using the screws removed.

CLEANING FAN PASSAGEWAYS

Carefully use a vacuum cleaner or compressed air to keep the fan compartment and blades free of dust and debris.

NOTE: The fan motor is pre-lubricated for extended bearing life and requires no further lubrication.

TROUBLESHOOTING



WARNING: If you smell gas:

1. Shut off gas supply.
2. Do not try to light any appliance.
3. Do not touch any electrical switch; do not use any phone in your building.
4. Immediately call your gas supplier from a neighbor's phone. Follow the gas supplier's instructions.
5. If you cannot reach your gas supplier, call the fire department.

IMPORTANT: Operating the heater where impurities in air exist may create odors. Cleaning supplies, paint, paint remover, cigarette smoke, cements and glues, new carpet or textiles, etc., create fumes. These fumes may mix with combustion air and create odors.



WARNING: Make sure that power is turned off before proceeding.



WARNING: Turn off and let cool before servicing. Only a qualified service person should service and repair heater.

PROBLEM	POSSIBLE CAUSE	CORRECTIVE ACTION
When Ignitor is pressed in, there is no spark at ODS/Pilot	<ol style="list-style-type: none"> 1. Ignitor electrode is positioned wrong 2. Ignitor electrode is broken 3. Ignitor electrode is not connected to ignitor cable 4. Ignitor cable is pinched or wet 5. Damaged ignitor cable 6. Bad ignitor or ignition module 7. Bad battery 	<ol style="list-style-type: none"> 1. Replace ODS 2. Replace ODS 3. Replace ignitor cable 4. Free ignitor cable if pinched by any metal or tubing. Keep ignitor cable dry 5. Replace ignitor cable 6. Replace ignitor or ignition module 7. Replace the battery
Unit shuts off after running a few minutes	<ol style="list-style-type: none"> 1. Gas supply is turned off or equipment shutoff valve is closed 2. Control knob not fully pressed in while pressing Ignitor 3. Air in gas lines when installed 4. ODS/Pilot is clogged 5. Control knob not in PILOT position 6. Depleted gas supply (propane) 	<ol style="list-style-type: none"> 1. Turn on gas supply or open equipment shutoff valve 2. Fully press in control knob while pressing Ignitor 3. Continue holding down control knob. Repeat igniting operation until air is removed 4. Clean ODS/pilot (see "Care and Maintenance" on page 24) or replace ODS/pilot assembly 5. Turn control knob to PILOT position 6. Contact local propane/LP gas company

TROUBLESHOOTING

PROBLEM	POSSIBLE CAUSE	CORRECTIVE ACTION
ODS/pilot lights but flame goes out when control knob is released	<ol style="list-style-type: none"> 1. Control knob is not fully pressed in 2. Control knob is not pressed in long enough 3. Equipment shutoff valve is not fully open 4. Thermocouple connection is loose 5. Thermocouple damaged 6. Control valve damaged 7. Inlet gas pressure is too high 	<ol style="list-style-type: none"> 1. Press in control knob fully 2. After ODS/pilot lights, keep control knob pressed in 30-60 seconds 3. Fully open equipment shut off valve 4. Hand tighten until snug, and then tighten 1/4 turn more 5. Replace thermocouple 6. Contact customer service 7. Contact your gas supplier to check and adjust the inlet pressure
Burner(s) does not light after ODS/pilot is lit	<ol style="list-style-type: none"> 1. Thermostat setting too low 2. Burner orifice is clogged 3. Burner orifice diameter is too small 4. Inlet gas pressure is too low 	<ol style="list-style-type: none"> 1. Turn thermostat knob to a higher setting 2. Clean burner orifice (see "Care and Maintenance" on page 24) or contact customer service 3. Contact customer service 4. Contact your gas supplier
Delayed ignition of burner(s)	<ol style="list-style-type: none"> 1. Manifold pressure is too low 2. Burner orifice is clogged 	<ol style="list-style-type: none"> 1. Contact your gas supplier 2. Clean burner orifice (see "Care and Maintenance" on page 24) or contact customer service
Burner backfiring during combustion	<ol style="list-style-type: none"> 1. Burner orifice is clogged or damaged 2. Burner is damaged 3. Gas regulator is damaged 	<ol style="list-style-type: none"> 1. Clean burner orifice (see "Care and Maintenance" on page 24) or contact customer service 2. Contact customer service 3. Contact dealer or customer service. Replace gas regulator
High yellow flame during burner combustion	<ol style="list-style-type: none"> 1. Not enough air 2. Gas regulator is defective 	<ol style="list-style-type: none"> 1. Check burner for dirt and debris. If found, Clean burner (see "Care and Maintenance" on page 24) or contact customer service 2. Contact dealer or customer service. Replace gas regulator
Gas odor during combustion	<ol style="list-style-type: none"> 1. Foreign matter between control valve and burner 2. Gas leak (see warning statement on page 25) 	<ol style="list-style-type: none"> 1. Take apart gas tubing and remove foreign matter 2. Locate and correct all leaks (see "Checking Gas Connections" on page 18)
Heater produces a clicking/ticking noise just after burner is lit or shut off	<ol style="list-style-type: none"> 1. Metal is expanding while heating or contracting while cooling 	<ol style="list-style-type: none"> 1. This is common with most heaters. If noise is excessive, contact a qualified service technician

TROUBLESHOOTING

PROBLEM	POSSIBLE CAUSE	CORRECTIVE ACTION
White powder residue forming within burner box or on adjacent walls or furniture	1. When heated, the vapors from furniture polish, wax, carpet cleaners, etc., turn into white powder residue	1. Turn heater off when using furniture polish, wax, carpet cleaner or similar
Heater produces unwanted odors	1. Heater is burning vapors from paint, hairspray, glues, etc. See IMPORTANT statement, page 21 2. Gas leak (see warning statement on page 25) 3. Low fuel supply	1. Ventilate room. Stop using odor causing products while heater is running 2. Locate and correct all leaks (see "Checking Gas Connections" on page 18) 3. Refill supply tank (propane/LP models)
Heater shuts off in use (ODS operates)	1. Not enough fresh air is Available 2. Low line pressure 3. ODS/pilot is partially clogged	1. Open window and/or door for Ventilation 2. Contact local gas supplier 3. Clean ODS/pilot (see "Care and Maintenance" on page 24)
Gas odor exists even when control knob is in OFF position	1. Gas leak (see warning statement on page 25) 2. Control valve is defective	1. Locate and correct all leaks (see "Checking Gas Connections" on page 18) 2. Contact customer service
Moisture/condensation noticed on windows	1. Not enough combustion/ventilation air	1. Refer to "Air for Combustion and Ventilation" on page 7
Slight smoke or odor during initial operation	1. Residues from manufacturing process	1. Problem will stop after a few hours of operation
Heater produces a whistling noise when burner is lit	1. Turning control knob to HIGH (5) position when burner is Cold 2. Air in gas line 3. Air passageways on heater are blocked 4. Dirty or partially clogged burner orifice	1. Turn control knob to LOW (1) position and let warm up for a minute 2. Operate burner until air is removed from line. Have gas line checked by local propane/LP gas company. 3. Observe minimum installation Clearances (see "Installation" on page 10) 4. Clean burner (see "Care and Maintenance" on page 24)
Fan is not spinning	1. There is no power to fan 2. Fan motor is bad	1. Verify fan is plugged in 2. Replace fan
Fan is making a loud noise	1. Fan housing or blades are Dirty 2. Fan rotation is blocked 3. Defective fan	1. Clean fan (see "Care and Maintenance" on page 24) 2. Verify wiring is not in fan path 3. Replace fan

REPLACEMENT PARTS LIST

For replacement parts, contact customer service at 519-442-4848 or email service@signitepro.com

WARNING: Only use genuine replacement parts from the manufacturer SignitePro Inc. Using any parts other than the original replacement parts may result in property damage, personal injury or even death.

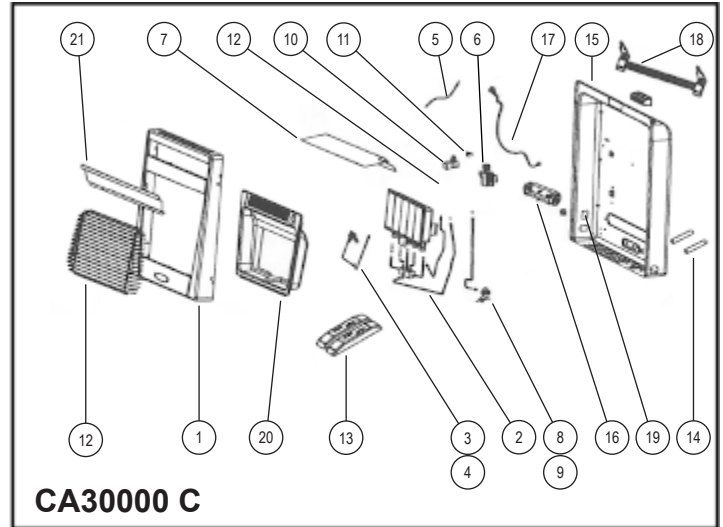
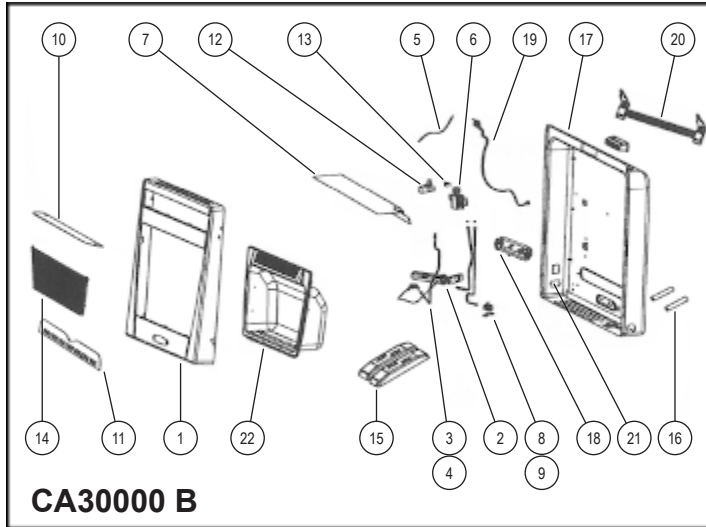

BLUE FLAME MODELS

NO.	DESCRIPTION	QTY.			
		CA30000B	CA30000BF	CA30000BL	CA30000BLF
1	Front Panel assembly	1	1	1	1
2	Burner Assembly (BF)	1	1	1	1
3	ODS - (LP) Propane Pilot	---	---	1	1
4	ODS - (NG) NG Pilot	1	1	---	---
5	Ignition Wire	1	1	1	1
6	Thermostatic Gas Valve	1	1	1	1
7	Thermal Barrier	1	1	1	1
8	NG Regulator - B	1	1	---	---
9	LPG Regulator - BL	---	---	1	1
10	Bracket of Furnace	1	1	1	1
11	Furnace Supporter	1	1	1	1
12	Ignitor Module	1	1	1	1
13	Ignitor Bracket	1	1	1	1
14	Front Grille	1	1	1	1
15	Support Leg	2	2	2	2
16	Spacer	2	2	2	2
17	Rear Side - Outer Casing	1	1	1	1
18	Fan Assembly	---	1	---	1
19	Cord Wire with Plug	---	1	---	1
20	Mounting Bracket	1	1	1	1
21	Switch	---	1	---	1
22	Furnace	2	2	2	2

INFRARED MODELS

NO.	DESCRIPTION	QTY.			
		CA30000C	CA30000CF	CA30000CL	CA30000CLF
1	Front Panel assembly	1	1	1	1
2	Burner Assembly (IR)	1	1	1	1
3	ODS - (LP) Propane Pilot	---	---	1	1
4	ODS - (NG) NG Pilot	1	1	---	---
5	Ignition Wire	1	1	1	1
6	Thermostatic Gas Valve	1	1	1	1
7	Thermal Barrier	1	1	1	1
8	NG Regulator - B	1	1	---	---
9	LPG Regulator - BL	---	---	1	1
10	Ignitor Module	1	1	1	1
11	Ignitor Bracket	1	1	1	1
12	Front Grille	1	1	1	1
13	Support Leg	2	2	2	2
14	Spacer	2	2	2	2
15	Rear Side - Outer Casing	1	1	1	1
16	Fan Assembly	---	1	---	1
17	Cord Wire with Plug	---	1	---	1
18	Mounting Bracket	1	1	1	1
19	Switch	---	1	---	1
20	Furnace	---	1	---	1
21	IR Furnace Deflector	1	1	1	1

WARRANTY

The manufacturer warrants that your new product is free from manufacturing and material defects for a period of one year from date of purchase, subject to the following conditions and limitations:

1. This product must be installed and operated at all times in accordance with the instructions furnished with the product. Any alteration, willful abuse, accident, or misuse of the product shall nullify this warranty.
 2. This warranty is non-transferable, and is made to the original owner, provided that the purchase was made through an authorized supplier of the manufacturer.
 3. This warranty is limited to the repair or replacement of part(s) found to be defective in material or workmanship, provided that such part(s) have been subjected to normal conditions of use and service, after said defect is confirmed by the manufacturer's inspection.
 4. The manufacturer may, at its discretion, fully discharge all obligations with respect to this warranty by refunding the wholesale price of the defective part(s).
 5. Any installation, labor, construction, transportation, or other related costs/expenses arising from defective part(s), repair, replacement or otherwise of same, will not be covered by this
- warranty, nor shall the manufacturer assume responsibility for same. Further, the manufacturer will not be responsible for any incidental, indirect, or consequential damages, except as provided by law.
6. All other warranties - expressed or implied with respect to the product, its components and accessories, or any obligations/liabilities on the part of the manufacturer are hereby expressly excluded.
 7. The manufacturer neither assumes, nor authorizes any third party to assume, on its behalf, any other liabilities with respect to the sale of this product.
 8. The warranties as outlined within this document do not apply to non-manufacturer accessories used in conjunction with the installation of this product.

This warranty is void if:

- a) The product has been operated in atmospheres contaminated by chlorine, fluorine or other damaging chemicals.
- b) The product is subjected to prolonged periods of dampness or condensation.
- c) Any alteration, willful abuse, accident, or misuse of the product.

IF WARRANTY SERVICE IS NEEDED ...

- 1) Contact customer service at 519-442-4848. Make sure you have your warranty, your sales receipt, and the model/serial number of your product.
- 2) ***DO NOT ATTEMPT TO DO ANY SERVICE WORK YOURSELF.***

WARRANTY REGISTRATION

IMPORTANT: We urge you to file your warranty registration within fourteen (14) days of date of purchase. Register your warranty on the internet at www.SignitePro.com or through your local distributor.



Application Questions? Missing Parts? Before returning appliance to retailer, please contact customer service department between 9am EST - 3pm EST @ (519) - 442-4848 email us at: service@signitepro.com