

VersaFlo® UP, UPS

Series 200 circulator pumps
60 Hz



Contents

Mission

General data

Terminal box modules	4
Applications	4
Pumped liquids	4
Type key	5
Nameplate	5

Performance range

UPS pumps	6
UP pumps	7

Cross-reference guide

Cross-reference guide: Armstrong, B&G and TACO to Grundfos	8
--	---

Product range

UPS range	10
UP range	10
Pump overview	11

Construction

Construction	12
Material specification	13
Motor	14
Stator housing	14
Rotor can	14
Shaft with rotor	14
Bearing plate	14
Impeller	14
Pump housing	14

Technical data

Pumped liquids	15
Temperature limits	15
Other technical data	15
Curve conditions	15
Electrical data	16
Terminal box	16
Supply voltage tolerances	17

Functions

Functions	18
Description of functions	19
Three-speed pumps	19
Two-speed pumps	19
Single-speed pumps	20
Pumps with standard module	20
Standard module indicator lights	20
Frequency converter operation	20
Pumps with protection module	21
Protection module indicator lights	21
Pumps with relay module	21
Relay module indicator lights	21
Signal output of relay module	21
Operating modes of two pumps plumbed in parallel	22

Product data

VersaFlo UPS	23
VersaFlo UP	27

Performance curves

UPS	28
UP	61

Accessories and spare parts

Packaged fitting sets	65
Flange adapter	65
Terminal box electrical components	65

Further product documentation

WebCAPS	66
WinCAPS	67

Mission

- to successfully develop, produce, and sell high quality pumps and pumping systems worldwide, contributing to a better quality of life and healthier environment.



GBJ - Bjerringbro, Denmark



GMU - Fresno, California



GPU - Olathe, Kansas



GMX - Monterrey, Mexico



GPA - Allentown, Pennsylvania



GCA - Oakville, Ontario

- One of the 3 largest pump companies in the world
- World headquarters in Denmark
- North American headquarters in Kansas City - Manufacturing in Fresno, California
- 73 companies in 41 countries
- More than 10 million pumps produced annually worldwide
- North American companies operating in USA, Canada and Mexico
- Continuous reinvestment in growth and development enables the company to **BE** responsible, **THINK** ahead, and **INNOVATE**

Terminal box modules

UPS pumps are equipped with a standard or protection module in the terminal box. Pumps with standard module must be connected to the mains via an external contactor, whereas pumps with protection module can be connected directly to the mains.

For further information about the different modules, see pages 20 through 21.

Applications

The pumps are designed for circulation of liquids in heating and air-conditioning systems. They can also be used in domestic hot-water systems.

To ensure optimum operation, the dimensioning range of the system must fall within the performance range of the pump. See data sheets.

Pumped liquids

Thin, clean, non-aggressive and non-explosive liquids, not containing any solid particles, fiber or mineral oil.

In domestic hot-water systems it is advisable to use bronze pumps only for water with a degree of hardness lower than approx. 14°dH. For water with a higher degree of hardness a TP dry-rotor pump is recommended.

The pumps must **not** be used for the transfer of inflammable liquids such as diesel oil and petrol.

Liquid temperature, see section Temperature limits on page 15.

Type key

Example	UPS	50	-40	(/2)	F	(B)
Type range						
- UP: Single-speed pump						
- UPS: Two- or three-speed pump						
Nominal flange diameter [mm]						
Max. head [dm]*						
Number of motor poles (stated if available both as 2- and 4-pole motor)						
Pump with flanges						
Pump with bronze housing						

* With the exception of the following pump types, where the number is to be considered as a reference number:
UP 53-45, UP 53-46, UPS 53-55/57 and UPS 75-69

Nameplate

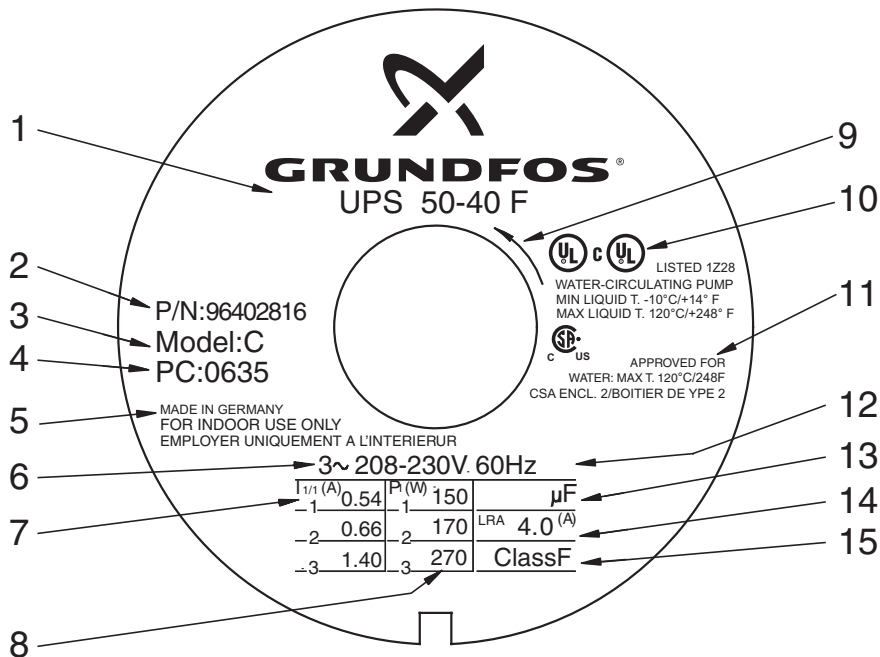

TM03 7712 4806

Fig. 1 Example of nameplate

Pos.	Description
1	Type code
2	Product number
3	Model designation
4	Production code (year + week)
5	Country of origin
6	Number of phases and rated voltage
7	Current at speeds 1, 2, 3
8	Power at speeds 1, 2, 3
9	Direction of rotation
10	Approvals
11	Temperature limits
12	Rated frequency
13	Capacitor size
14	Locked Rotor Amps
15	Insulation class

UPS pumps

The curves show maximum performance curves for the UPS range:

- single-voltage pumps
- two- and three-speed pumps.

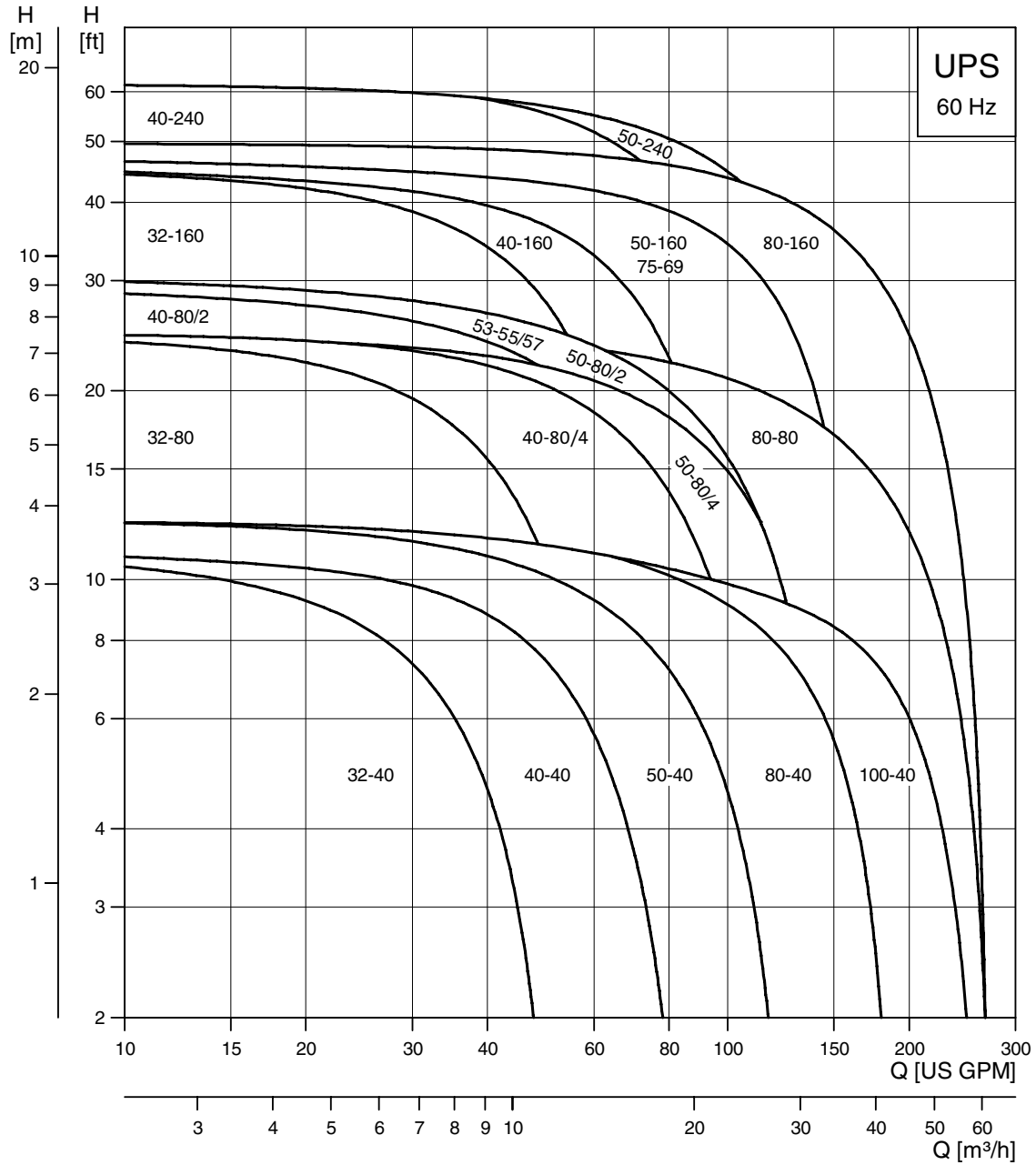

TM00 9582 5106

UP pumps

The curves show maximum performance curves for the UP range:

- dual-voltage pumps
- single-speed pumps.

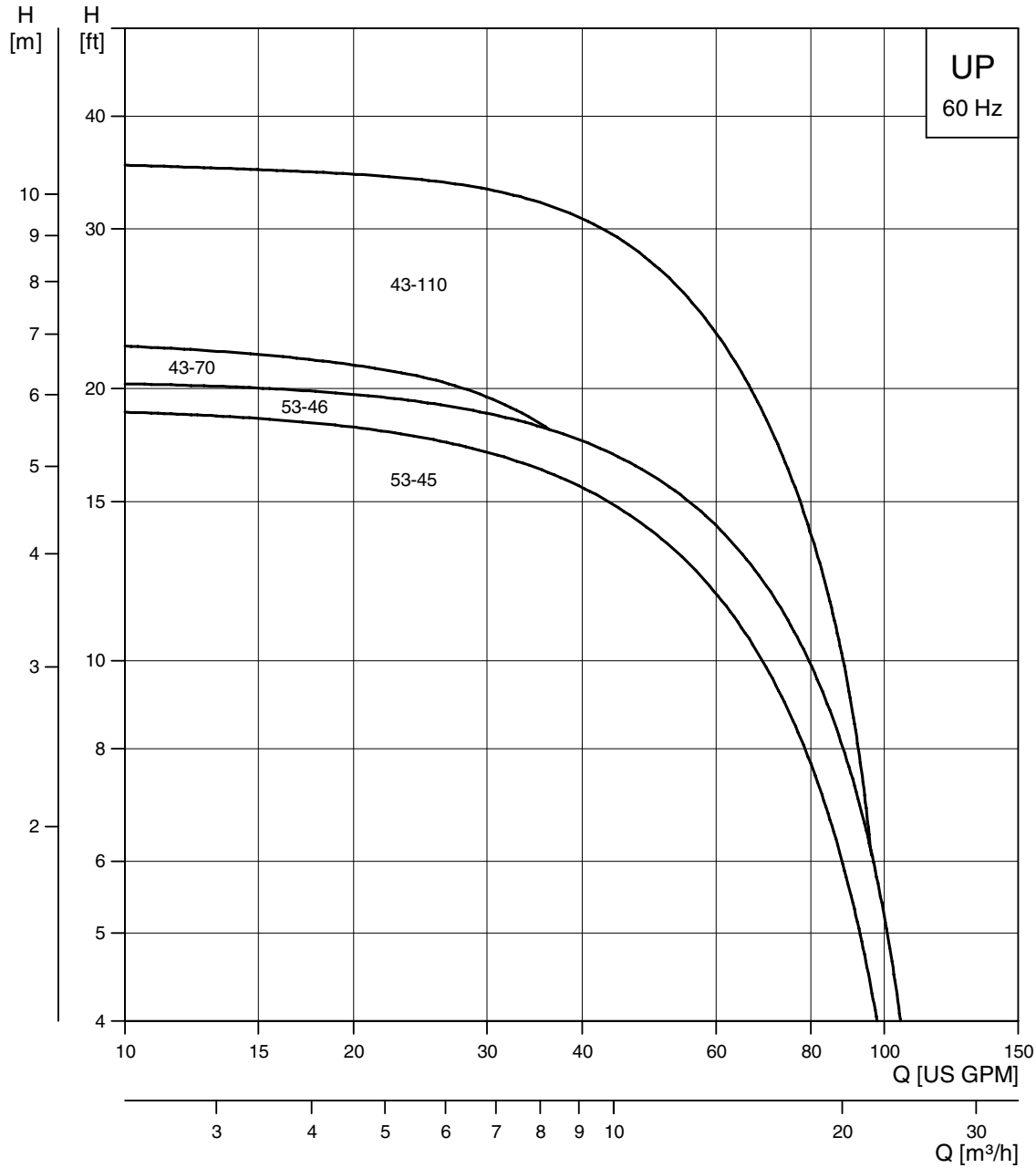

TM02 5598 4706

Cross-reference guide: Armstrong, B&G and TACO to Grundfos

Manufacturer	Model	Port-to-port length	Flange size	Grundfos model	Port-to-port length	Flange size	
Armstrong	ARMflo E21	8-1/2"	1-1/2"	UP43-110F	8-1/2"	1-1/2"	
	ARMflo E23	8-1/2"	1-1/2"	UP43-110F	8-1/2"	1-1/2"	
	S 45	10"	2-1/2", 3"	UP53-45F*	9-7/8"	2", 2-1/2", 3"	
	S 46	10"	2-1/2", 3"	UP53-46F*	9-7/8"	2", 2-1/2", 3"	
	S 55	12"	3"	UPS53-55/57F*	11-7/8"	2", 2-1/2", 3"	
	S 57	12"	3"	UPS53-55/57F*	11-7/8"	2", 2-1/2", 3"	
	S 69	14-1/4"	3"	UPS75-69F*	14"	2", 2-1/2", 3"	
	H51	11-1/2"	1"	UPS32-80/2*□	11"	2", 2-1/2", 3"	
	H52	11-1/2"	1"	UPS32-80*□	11"	3/4" to 1-1/2"	
	H53	11-1/2"	1-1/2"	UPS40-160/2*	11-1/2"	1-1/2"	
	H54	11-1/2"	2"	UPS50-80/2*	11-1/2"	2-1/2"	
	H63	13-1/2"	1-1/2"	UPS32-160/2*	13-1/2"	1-1/2"	
	H64	13-1/2"	1-1/2"	UPS32-160/2*	13-1/2"	1-1/2"	
	H65	13-1/2"	1-1/2"	UPS40-240/2*	13-1/2"	1-1/2"	
	H66	14"	2"	UPS50-160/2*	14"	2"	
	H67	14"	2"	UPS50-160/2*	14"	2"	
	H68	14"	2"	UPS50-240/2*	14"	2"	
	1050 1B (1/4HP)	11-1/2"	1"	UPS32-80/2*□	11"	3/4" to 1-1/2"	
	1050 1-1/4B (1/4HP)	11-1/2"	1-1/4"	UPS32-80/2*□	11"	3/4" to 1-1/2"	
	1050 1-1/2B (1/4HP)	11-1/2"	1-1/2"	UPS32-80/2*□	11"	3/4" to 1-1/2"	
	1050 2B (1/3HP)	11-1/2"	2"	UPS50-80/4*	11-1/2"	2"	
	1050 2B (1/2HP)	11-1/2"	2"	UPS50-80/4*	11-1/2"	2"	
	1050 2B (3/4HP)	11-1/2"	2"	UPS50-80/4*	11-1/2"	2"	
	1060 1-1/2 D (1/2HP)	13-1/2"	1-1/2"	UPS32-160/2*	13-1/2"	1-1/2"	
	1060 1-1/2 D (3/4HP)	13-1/2"	1-1/2"	UPS32-160/2*	13-1/2"	1-1/2"	
	1060 1-1/2 D (1-1/2HP)	13-1/2"	1-1/2"	UPS40-240/2*	13-1/2"	1-1/2"	
	1060 2D (3/4HP)	14"	2"	UPS50-160/2*	14"	2"	
	1060 2D (1HP)	14"	2"	UPS50-160/2*	14"	2"	
	1060 2D (1-1/2HP)	14"	2"	UPS50-160/2*	14"	2"	
	1060 2D (2HP)	14"	2"	UPS50-240/2*	14"	2"	
	TACO	120	11"	2"	UPS32-40/4*□	11"	3/4" to 1-1/2"
		131	13-5/8"	3"	UP53-45F*□	10"	2"
133		13-5/8"	3"	UPS53-55/57*□	11-7/8"	3"	
1600		10-1/4"	1-1/2"	UPS32-80/2*	11"	1-1/2"	
1610		10-1/4"	1-1/2"	UPS32-80/2*	11"	1-1/2"	
1612		13-1/2"	1-1/2"	UPS32-160/2*	13-1/2"	1-1/2"	
1614		13-1/2"	1-1/2"	UPS32-160/2*	13-1/2"	1-1/2"	
1616		14-1/2"	2"	UPS40-240/2*□	13-1/2"	1-1/2"	
1630		13-1/2"	2"	UPS50-80/4*□	11-1/2"	2"	
1632		13-1/2"	2"	UPS50-160/2*	14"	2"	
1634		13-1/2"	2"	UPS50-160/2*	14"	2"	
1636		16-1/2"	2"	UPS50-240/2*□	14"	2"	
1638		16-1/2"	2"	UPS50-240/2*□	14"	2"	

* Bronze version to be used in open systems.
□ Replacement model requires piping and/or flange modification.

Disclaimer: This cross-reference is a guide only. Use individual technical data sheets for correct comparison.

Cross-reference guide

VersaFlo® UP, UPS

Manufacturer	Model	Port-to-port length	Flange size	Grundfos model	Port-to-port length	Flange size
B&G	2-1/2"	10"	2-1/2"	UP53-45F★	9-7/8"	2", 2.5", 3"
	LD3	10"	3"	UP53-45F★	9-7/8"	2", 2.5", 3"
	HD3	10"	3"	UP53-46F★	9-7/8"	2", 2.5", 3"
	PD-35	12"	3"	UPS53-55/57F★	11-7/8"	2", 2.5", 3"
	PD-37	12"	3"	UPS53-55/57F★	11-7/8"	2", 2.5", 3"
	PD-38	14-1/2"	3"	UPS75-69F★	14"	2", 2.5", 3"
	PD-40	14-1/2"	3"	UPS50-160/2★□	14"	2"
	601	11"	1"	UPS32-80/2★	11"	3/4" to 1-1/2"
	602	11"	1"	UPS32-80/2★	11"	3/4" to 1-1/2"
	603	11"	1"	UPS50-80/2★□	11-1/2"	2"
	604	11"	1-1/4"	UPS32-80/2★	11"	3/4" to 1-1/2"
	609	11-1/2"	1-1/2"	UPS40-160/2★	11-1/2"	1-1/2"
	610	11-1/2"	2"	UPS50-80/4★	11-1/2"	2"
	621	13-1/2"	2"	UPS40-80/4	13-1/2"	1-1/2"
	614	13-1/2"	1-1/2"	UPS40-240/2	13-1/2"	1-1/2"
	615	13-1/2"	2"	UPS50-160/2	14"	2"
	616	13-1/2"	2"	UPS50-160/2	14"	2"
	622	13-1/2"	1-1/2"	UPS32-160/2	13-1/2"	3/4" to 1-1/2"
	623	13-1/2"	1-1/2"	UPS40-240/2	13-1/2"	1-1/2"
	617	13-1/2"	1-1/2"	UPS40-240/2	13-1/2"	1-1/2"
	624	14"	2"	UPS50-160/2	14"	2"
	625	14"	2"	UPS50-240/2	14"	2"
	60-11	11"	1-1/4"	UPS32-80/2★	11"	3/4" to 1-1/2"
	60-13	11-1/2"	1-1/2"	UPS40-160/2★	11-1/2"	1-1/2"
	60-14	11-1/2"	2"	UPS50-80/2★	11-1/2"	2"
	60-15	13-1/2"	1-1/2"	UPS32-160/2	13-1/2"	3/4" to 1-1/2"
	60-16	13-1/2"	1-1/2"	UPS32-160/2	13-1/2"	3/4" to 1-1/2"
	60-17	13-1/2"	1-1/2"	UPS40-240/2	13-1/2"	1-1/2"
	60-19	14"	2"	UPS50-160/2	14"	2"
	60-20	14"	2"	UPS50-160/2	14"	2"
60-21	14"	2"	UPS50-240/2	14"	2"	

★ Bronze version to be used in open systems.

□ Replacement model requires piping and/or flange modification.

Disclaimer: This cross-reference is a guide only. Use individual technical data sheets for correct comparison.

UPS range

Pump type	Voltage [V]					Poles	
	1 x 115	1 x 230	3 x 208-230	3 x 460	3 x 575★	2	4
UPS 32-40 F	●	●	●	●	●		●
UPS 32-80 F	●	●	●	●	●	●	
UPS 32-160 F	●	●	●	●	●	●	
UPS 40-40 F	●	●	●	●	●		●
UPS 40-80/2 F	●	●	●	●	●	●	
UPS 40-80/4 F	●	●	●	●	●		●
UPS 40-160 F	●	●	●	●	●	●	
UPS 40-240 F	●	●	●	●	●	●	
UPS 50-40 F	●	●	●	●	●		●
UPS 50-80/2 F	●	●	●	●	●	●	
UPS 50-80/4 F	●	●	●	●	●		●
UPS 50-160 F		●	●	●	●	●	
UPS 50-240 F			●	●	●	●	
UPS 53-55/57 F	●	●	●	●	●	●	
UPS 75-69 F		●	●	●	●	●	
UPS 80-40 F			●	●	●		●
UPS 80-80 F			●				●
UPS 80-160 F			●	●	●	●	
UPS 100-40 F			●	●	●		●

★Canada only

UP range

Pump type	Voltage [V]		Poles	
	1 x 115/230 V		2	4
UP 43-70 F		●		●
UP 43-110 F		●		●
UP 53-45 F		●		●
UP 53-46 F		●		●

Pump overview

Model	Flow U.S. GPM	Head feet	PH	Max. rpm	Flange	Flange type
UP 43-70F	15-100	1-23	1	3450	1 1/2" non ANSI 2 bolt w/ (2) 1/2" dia. holes	GF 40/43
UP 43-110F	15-105	1-37	1	3450	1 1/2" non ANSI 2 bolt w/ (2) 1/2" dia. holes	GF 40/43
UP 53-45 F	15-100	1-23	1	3450	2", 2 1/2", 3" non ANSI 4 bolt w/ (4) 5/8" dia. holes	GF 53
UP 53-46 F	15-105	1-37	1	3450	2", 2 1/2", 3" non ANSI 4 bolt w/ (4) 5/8" dia. holes	GF 53
UPS 32-40/4	9-52	1-11	1-3	1750	1 1/4" non ANSI 4 bolt w/ (4) 5/8" dia. holes	GF 15/26
UPS 32-80/2	9-67	1-25	1-3	3450	1 1/4" non ANSI 2 bolt w/ (2) 1/2" dia. holes	GF 15/26
UPS 32-160/2	9-76	1-45	1-3	3450	1 1/2" non ANSI 2 bolt w/ (2) 1/2" dia. holes	GF 40/43
UPS 40-40/4	13-85	1-11	1-3	1750	1 1/2" non ANSI 2 bolt w/ (2) 1/2" dia. holes	GF 40/44
UPS 40-80/2	13-105	1-30	1-3	3450	1 1/2" non ANSI 2 bolt w/ (2) 1/2" dia. holes	GF 40/45
UPS 40-80/4	13-120	1-25	1-3	1750	1 1/2" non ANSI 2 bolt w/ (2) 1/2" dia. holes	GF 40/46
UPS 40-160/2	13-110	1-46	1-3	3450	1 1/2" non ANSI 2 bolt w/ (2) 1/2" dia. holes	GF 40/47
UPS 40-240/2	13-130	1-62	1-3	3450	1 1/2" non ANSI 2 bolt w/ (2) 1/2" dia. holes	GF 40/48
UPS 50-40/4	20-125	1-12	1-3	1750	2" non ANSI 4 bolt w/ (4) 9/16" dia. holes	GF 50
UPS 50-80/4	20-160	1-24	1-3	1750	2" non ANSI 4 bolt w/ (4) 9/16" dia. holes	GF 50
UPS 50-80/2	20-150	1-30	1-3	3450	2" non ANSI 4 bolt w/ (4) 9/16" dia. holes	GF 50
UPS 50-160/2	20-170	1-46	1-3	3450	2" non ANSI 4 bolt w/ (4) 9/16" dia. holes	GF 50
UPS 50-240/2	20-180	1-62	3	3450	2" non ANSI 4 bolt w/ (4) 9/16" dia. holes	GF 50
UPS 53-55/57 F	20-150	1-30	1-3	3450	2", 2 1/2", 3" ANSI 4 bolt w/ (4) 5/8" dia. holes	GF 53
UPS 75-69 F	20-170	1-46	1-3	3450	2", 2 1/2", 3" ANSI 4 bolt w/ (4) 12/16" dia. holes	GF 75
UPS 80-40/4	30-200	1-13	3	1750	3" ANSI 125# R.F.	GF 80
UPS 80-80/4	30-260	1-25	3	1750	3" ANSI 125# R.F.	GF 80
UPS 80-160/2	30-275	1-49	3	3450	4" ANSI 125# R.F.	GF 80
UPS 100-40/4	30-270	1-12	3	1750	4" ANSI 125# R.F.	GF 100

Construction

UP(S) Series 200 pumps are of the canned rotor type, i.e. pump and motor form an integral unit without shaft seal and with only two gaskets for sealing. The bearings are lubricated by the pumped liquid.

Attention has been focused on using as few materials as possible, and the use of materials that might cause problems in connection with disposal have been omitted.

Features:

- UPS motors are two- or three-speed motors. UP motors are single-speed dual-voltage motors.
- Stainless steel rotor can, bearing plate and rotor cladding.
- Stator housing in aluminum alloy.
- Cast iron or bronze pump housing.
- Stator with built-in thermal overload switch.

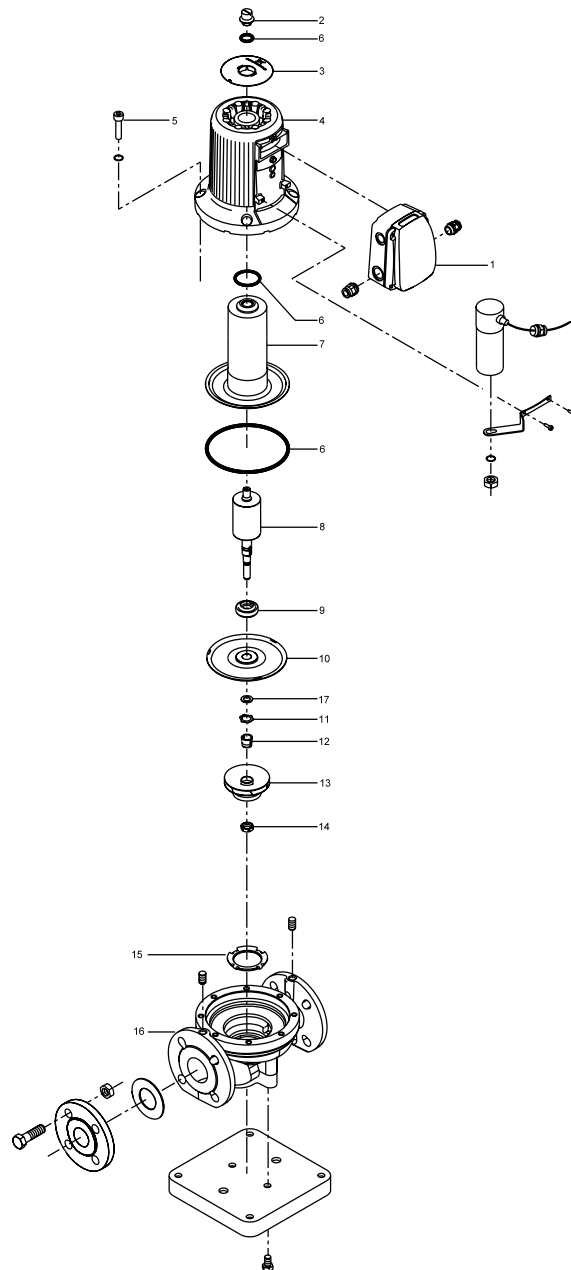

Fig. 2 Exploded view of a VersaFlo UP(S) Series 200 pump

TM03 7880 5106

Material specification

Pos.	Description	Material	AISI/ASTM
1	Terminal box	Composite PA66	
2	Inspection screw	Brass with nickel	
3	Nameplate	Composite PA66	
4	Stator housing	Aluminium AISi10Cu ₂	
	Stator windings	Copper wire	
4	Stator caps	Composite PETP	
5	Cheese-head screw	Steel 8.8	
6	O-rings	EPDM rubber	
7	Outer bearing ring	Aluminium oxide/SiC	
	Rotor can	Stainless steel	AISI 304
8	Shaft (cast-iron pumps)	Stainless steel	AISI 303
	Shaft (bronze pumps)		AISI 316
8	Rotor cladding	Stainless steel	AISI 304
	Bearing	Tungsten carbide	

Pos.	Description	Material	AISI/ASTM
9	Thrust bearing	Carbon MY 106	
10	Bearing plate	Stainless steel	AISI 304
	Inner bearing ring	Aluminium oxide/SiC	
11	Stop ring	Stainless steel	
12	Split cone	Stainless steel	AISI 303
13	Impeller	Stainless steel	AISI 304
14	Nut	Stainless steel	AISI 303
15	Neck ring	Stainless steel/PTFE	AISI 304
		Cast iron EN-GJL-250	
16	Pump housing	Bronze CuSn10, DIN 1705	ASTM B505 and B271
17	Anti-friction ring	PTFE	
18	Splash protector	Stainless steel	AISI 303

Sectional drawing

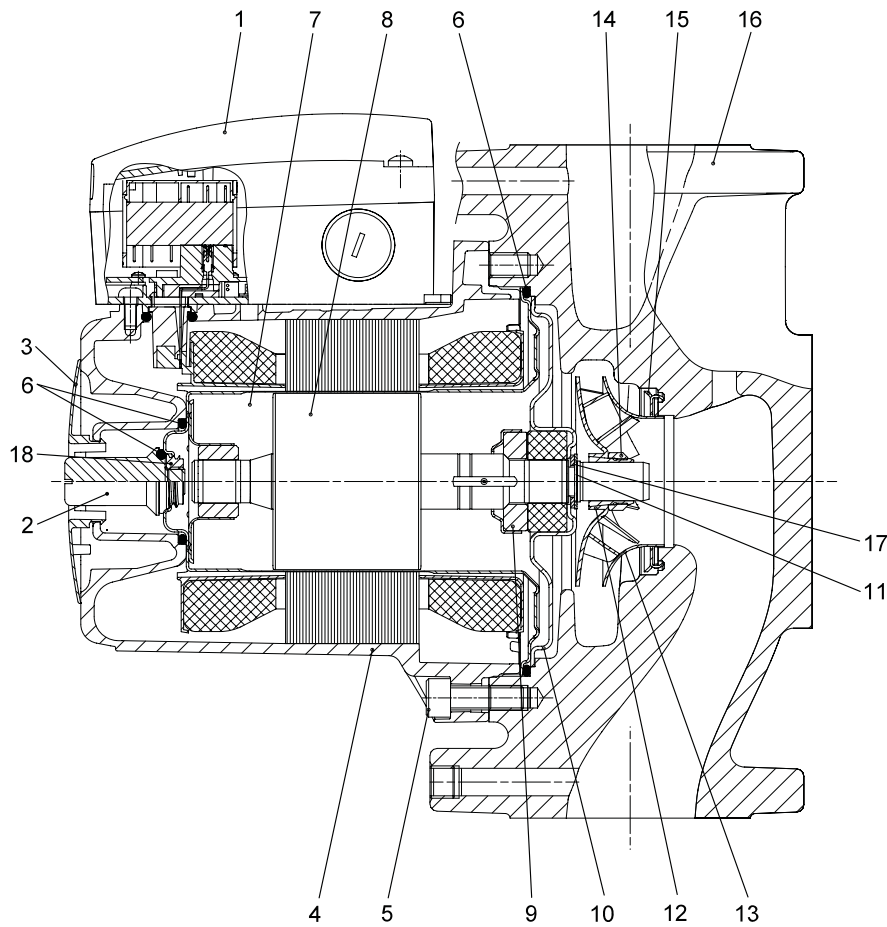

Fig. 3 Sectional view

TM02 1397 0907

Motor

The motor, pos. 4, is a 2- or 4-pole, asynchronous squirrel-cage motor. As the motor is cooled by the pumped liquid, the noise level is very low.

Stator housing

Pressure die-cast aluminum stator housing can be turned to change the position of the terminal box.

The stator housing has eight drain holes to enable condensed water to escape. The vent hole under the terminal box allows the water to evaporate from the stator. The drain holes must point downwards.

The permissible terminal box positions are shown in the drawing below. The positions apply to both vertical and horizontal mounting.

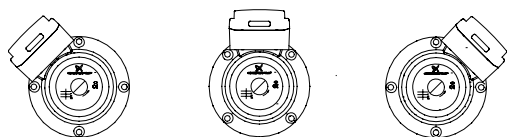

Fig. 4 Possible terminal box positions

TM02 1398 1101

Note: The terminal box must only be turned to the above positions.

The drawing below shows the standard box position.

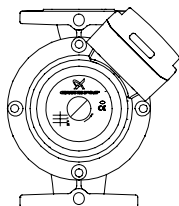

Fig. 5 Standard terminal box position

TM03 2260 4005

The nameplate can be turned in steps of 45°.

The positions of the terminal box and the nameplate are changed as described above.

The stator wires are self-bonding. The wires and the terminal box are connected by a terminal plug.

The stator incorporates a thermal overload switch for protection of the motor if the winding temperature becomes too high.

Rotor can

The rotor can, pos. 7, is made of drawn steel sheet and fitted with an inspection screw directly at the top.

There is an O-ring seal between the inspection screw and the rotor can. For reasons of safety, the hole for the inspection screw will deflect a possible jet of liquid if the inspection screw is removed.

The outer radial bearing is fitted into the top of the rotor can.

Shaft with rotor

The shaft, pos. 8, is made of stainless steel and equipped with two tungsten carbide bearings.

To further improve the internal circulation of the pumped liquid in the rotor can, the shaft of 4-pole motors is fitted with a small rotor impeller.

The rotor is made of soft-annealed iron lamination and provided with copper or brass bars. The short-circuit rings are made of copper.

The rotor is encapsulated in a thin stainless steel cladding and dynamically balanced.

The thrust bearing is secured to the shaft in a spherically flexible suspension.

Bearing plate

The bearing plate, pos. 10, is made of stainless steel.

The inner radial bearing is pressed into the bearing plate, ground and honed. The relatively large bearing plate surface means that motor heat is effectively carried away by the pumped liquid.

Impeller

The stainless steel impeller, pos. 13, is of the radial type with curved blades. It is secured to the shaft by a split cone and nut (left-hand thread).

Pump housing

The pump housing, pos. 16, is available in cast iron or bronze. All pump housings are flanged for the individual markets. See also Product range concerning flanges and Product numbers concerning port-to-port lengths.

The pump housing is of the in-line type. A stainless steel/PTFE neck ring minimizes the recirculation and improves pump efficiency.

The bottom of the housing has threaded holes for fastening to a base plate.

Pumped liquids

CAUTION: This pump is intended for use with water only.

Your VersaFlo UP(S) pump can be used to circulate

- potable hot water
- water for hydronic heating
- cooling water.

In domestic hot-water systems it is advisable to use a bronze pump (VersaFlo UP(S) model) only for water with a degree of hardness lower than 14 grains per gallon of hardness. For water with a higher degree of hardness, a direct coupled VersaFlo TP pump is recommended.

If the pump is installed **in a heating system**, the water should meet the requirements of accepted standards on water quality in heating systems.

The pump is lubricated and cooled by the liquid being pumped. Therefore, the pumped liquid must always be allowed to circulate through the pump. Extended periods without circulation will cause premature wear to the bearings and excessive motor heat. The pumped liquid must also meet the following requirements.

The pumping of liquids with densities or kinematic viscosities higher than those of water will cause

- a considerable pressure drop
- a drop in the hydraulic performance
- a rise in the power consumption.

In these situations, contact Grundfos for assistance.

Temperature limits

Ambient air temperature: 32°F to 104°F.

Fluid temperature, open systems: 140°F.

Fluid temperature, closed systems:

- UPS pumps: 248°F.
- UP pumps: 230°F.

Other technical data

Relative humidity: Max. 95%.

Sound-pressure level: The sound-pressure level of the pump is lower than 41 dB(A) (reference: 20 mPa).

Max. working pressure: 145 psi.

Approvals: See the pump nameplate.

Inlet pressure

To avoid cavitation noise, the following minimum pressures are required at the pump suction flange:

UP(S) model	Liquid temperature					
	167°F 75°C		194°F 90°C		230°F 110°C	
	[psi]	hf	[psi]	hf	[psi]	hf
UPS 32-40	0.7	1.6	2.2	5.1	21	48.5
UPS 32-80	0.7	1.6	5.1	11.8	23.9	55.2
UPS 32-160	11.6	26.8	16	37	34.1	78.8
UPSD 40-40	0.7	1.6	4.4	10.2	23.2	53.6
UPS 40-80/4	0.7	1.6	1.5	3.5	18.1	41.8
UPS40-80/2	6.5	15	10.9	25.2	29	67
UPS 40-160	5.1	11.8	9.4	21.7	27.6	63.8
UPS 40-240	11.6	26.8	16	37	34.1	78.8
UPS 50-40	0.7	1.6	2.9	6.6	21.8	50.4
UPS 50-80/4	0.7	1.6	4.4	10.2	23.2	53.6
UPS 50-80/2	4.4	10.2	8.7	20.1	26.8	61.9
UPS 50-160	11.6	26.8	16	37	34.1	78.8
UPS 50-240	10.2	23.6	14.5	33.5	32.6	75.1
UPS 53-55/57	4.4	10.2	8.7	20.1	26.8	61.9
UPS 75-69	11.6	26.8	16	37	34.1	78.8
UPS 80-40	11.6	26.8	16	37	34.1	78.8
UPS 80-80	14.5	33.5	18.9	43.7	37	85.5
UPS 80-160	21.8	50.4	26.1	60.3	43.5	100.5
UPS 100-40	27.6	63.8	31.9	73.7	50	115.5
UP 43-70F	0.7	1.6	4.8	11	15.4	35.6
UP 43-110	3.6	8.4	8.2	19	18.9	43.7
UP 53-45	2.9	6.6	7.5	17.3	18.1	41.8
UP 53-46	1.1	2.5	5.8	13.4	16.4	37.9

Curve conditions

The guidelines listed below, apply to the performance curves found on pages 28-64;

1. Because of the danger of overheating the pumps must not be used at a flow below 0.1 x Q at best efficiency point.
2. The bold parts of the curves show the **recommended** performance range.
3. Test liquid: Airless water.
4. The curves apply to a liquid temperature of 68°F (20°C).

All curves show average values and **should not be used as guarantee curves**. If a stated minimum performance is required, individual measurements must be made.

Electrical data

Supply voltage and frequency

UPS: 115 V, 230 V, 1-phase 60 Hz, 208-230 V, 460 V, 575 V, 3 phase 60 Hz.

UP: 115 V, 230V, 1-phase 60 Hz, 460 V, 575 V, 3-phase 60Hz.

Back-up fuse: Max. 10 A.

Enclosure class: IP 44 indoor use only.

Terminal box

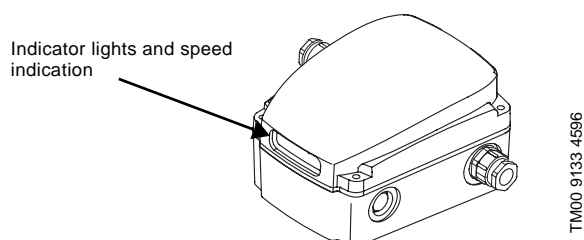

Fig. 6 Terminal box

The terminal box with cover, pos. 1, is made from black composite material.

The terminal box is equipped with:

- 1 x 1½" NPT screwed cable entry for mains connection, to be fitted during installation.
- 1 x M16 screwed cable entry for capacitor connection (only single-phase pumps)
- 2 x indicator lights (single-phase pumps with standard module have just one).
Note: UPS pumps only.
- window for indication of speed.
Note: UPS pumps only.

The terminal box is fastened to the stator housing with screws and connected to the stator by a terminal plug.

Insulation class

Pump type	Insulation class	
	1 x 115 V 1 x 230 V	3 x 208-230 V 3 x 460 V 3 x 575 V
32-40	F	F
32-80	F	F
32-160	H	F
40-40	F	F
40-80/4	H	H
40-80/2	F	F
40-160	H	H
40-240	H	H
50-40	F	F
50-80/4	H	H
50-80/2	H	F
50-160	H	H
50-240		H
53-55/57	H	F
75-69	H	H
80-40		H
80-80		H
80-160		H
100-40		H

UP

Pump type	Insulation class
UP	1 x 115/230 V
43-70	F
43-110	F
53-45	F
53-46	F

Thermal overload switch

Voltage	250 V AC
Current	cos phi = 1.0: 2.5 A cos phi = 0.6: 1.6 A

Start/stop input (relay module)

External potential-free contact.

Maximum load: 250 V, 1.5 mA.

Minimum load: 100 V, 0.5 mA.

Operating/fault signal output (relay module)

Internal potential-free changeover contact.

Maximum load: 250 V, 2 A, AC.

Minimum load: 5 V, 100 mA, DC.

Supply voltage tolerances

The motors meet the requirements to temperature rise at plus/minus 6%.

Furthermore, the motors have been tested at plus/minus 10% of the voltage ranged. During these tests, the motors operate without problems and without being thermally cut out.

The motor voltage tolerances are intended for mains voltage variations. They should not be used for running motors at other voltages than those stated on the name plates.

Variable speed applications

All 3 x 460 V, 3 x 575 V and 3-speed 3 x 208-230 V pumps with standard module are suitable for frequency converter applications. Please refer to page 20 for further information.

Functions

Pump model	VersaFlo UP, UPS terminal box includes				Additional terminal box options		External contactor required	Number of speeds		
	Voltage options	Speed switch	Standard module	Protection module	Terminal block	Protection module			Relay module	
UPS 32	1 x 115/230	■		■			●	3		
	3 x 208/230	■	■			●	●	3		
	3 x 460	△			■			□		
	3 x 575 ★	△			■			□		
UPS 40	1 x 115/230	■		■			●	3		
	3 x 208/230	■	■			●	●	3		
	3 x 460	△			■			□		
	3 x 575 ★	△			■			□		
UPS 50	1 x 115/230	■		■			●	3		
	3 x 208/230	■	■			●	●	3		
	3 x 460	△			■			□		
	3 x 575 ★	△			■			□		
UPS 53-55/57	1 x 115/230	■		■			●	3		
	1 x 230	■		■			●	3		
	3 x 208/230	■	■			●	●	3		
	3 x 460	△			■			□		
UPS 75-69	1 x 230	■		■			●	3		
	3 x 208/230	■		■			●	3		
	3 x 460	■	■			●	●	3		
	3 x 575 ★	△			■			□		
UPS 80	1 x 115/230	■		■			●	3		
	3 x 208/230	■	■			●	●	3		
	3 x 460	△			■			□		
	3 x 575 ★	△			■			□		
UPS 100	1 x 115/230	■		■			●	3		
	3 x 208/230	■	■			●	●	3		
	3 x 460	△			■			□		
	3 x 575 ★	△			■			□		
UP 43-70	1 x 115/230				■			□	1	
UP 43-110	1 x 115				■				□	1
UP 53-45	1 x 115/230				■				□	1
UP 53-46	1 x 115/230				■				□	1

★ Canada only

■ Standard

△ The speed is changed by reconfiguring the jumper positions, located in the terminal box.

● Optional

□ Required

◆ External contactor is not required when using the Protection module option.

Standard module: Indicator lights with no motor protection. For motor protection, use Protection module for 1 x 115/230 V and 3 x 208/230 V units or use an external contactor.

Protection module: Indicator lights with built-in motor protection. Connect directly to line voltage.

Note: Pumps with protection module must not be connected to a frequency converter.

Relay module: Indicator lights with signal output for external control or fault indication (1 x 115/230 V or 3 x 208/230 V units only).

External contactor required: Pump must be connected to line voltage via an external contactor. The contactor is to be connected to the pump's build-in thermal overload terminals. The speed is changed by orientation of the internal jumpers.

Description of functions

Three-speed pumps

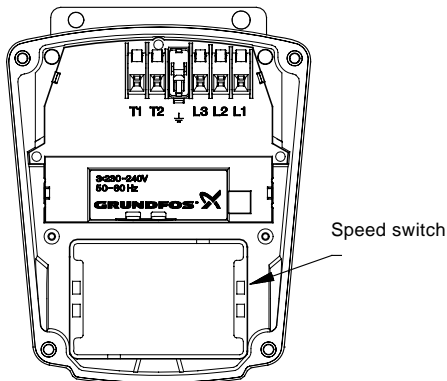

Fig. 7 3 x 208/230V terminal box

By means of the speed switch, the pump performance can be adjusted to suit the system in question.

For 1 x 115/230 V and 3 x 208/230 V three-speed pumps only. The module is located inside the terminal box. It has three positions:

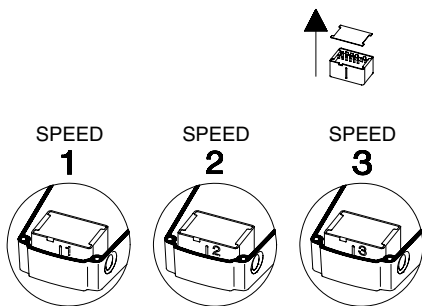

Fig. 8 Speed switch module

Switch position	Speed in % of maximum speed	
	Single-phase pumps	Three-phase pumps
1	approx. 60%	approx. 70%
2	approx. 80%	approx. 85%
3	100%	100%

Note: UP pumps runs at 100%.

Change to a lower speed enables considerable reduction in energy consumption and less noise in the system.

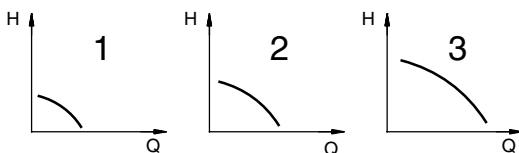

Fig. 9 Pump performance at the three speeds

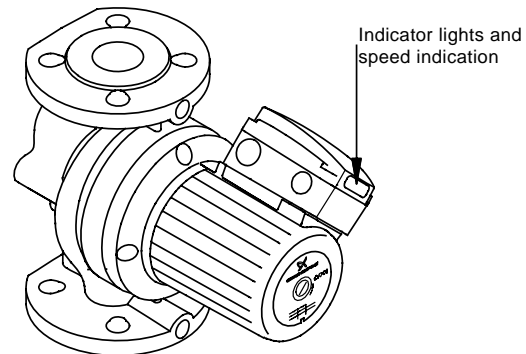

Fig. 10 VersaFlo UPS Series 200 pump with terminal box mounted

Two-speed pumps

All UPS pumps with 3 x 460 V & 575 V terminal boxes are fitted with a special two-speed terminal block.

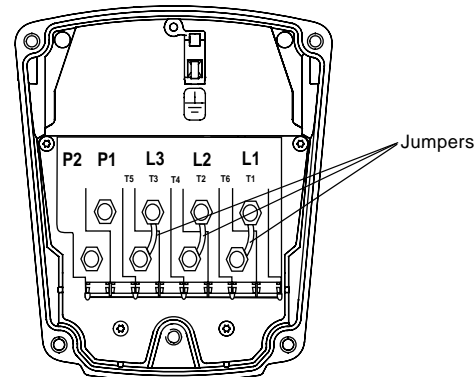

Fig. 11 3 x 460 V & 575 V terminal box

The speed is changed by changing the jumper positions.

The pump must be connected to the mains via an external contactor. The contactor is to be connected to the pump's built-in thermal overload switch (terminals P1 and P2) to protect the pump against overheating at both speeds.

Speed selection (two-speed, 3 x 460 V and 575 V)

The speed setting in the terminal box can be changed to two positions. The speed in the two positions appears in the table below

Speed step	Speed in % of maximum
1	Approx. 75%
2	100%

Single-speed pumps

UP pumps (1 x 115/230 V)

UP pumps are single-speed pumps with a 1 x 115 V/ 230 V terminal box with a dual-voltage terminal block. See figure below.

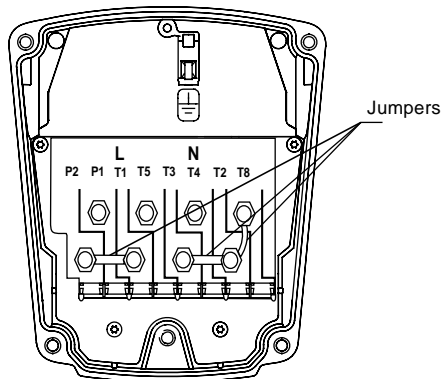

TM02 5761 3902

Fig. 12 1 x 115/230 V terminal box

The voltage is changed by changing the orientation of the jumpers. See above.

The pump must be connected to the mains via an external mains switch. The UP pumps are equipped with a built-in, automatically resetting terminal overload switch, protecting the pump at both 115 V and 230 V. The built-in terminal overload switch (terminals P1 and P2) can optionally be connected to external overload protection.

Pumps with standard module

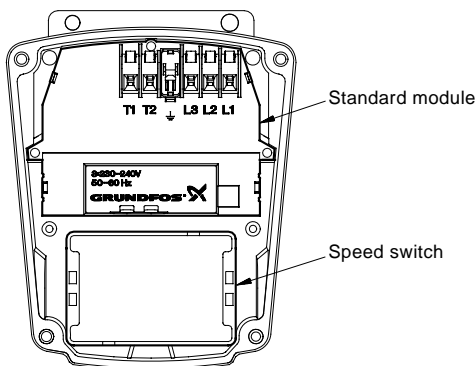

TM00 9237 4597

Fig. 13 Terminal box with standard module

The standard module is standard in three-phase pumps with three speeds and forms connection between supply terminals and motor.

The pumps with standard module must be connected to the mains via an external contactor.

For motor protection the contactor is to be connected to the pump's built-in thermal overload switch to protect the pump against overheating at all three speeds.

Standard module indicator lights

The indicator lights on pumps with standard module show whether the pump is live, or whether the phase sequence of three-phase pumps is wrong.

Single-phase pumps

Single-phase pumps incorporate a green indicator light only:

Indicator light	Description
On	The electricity supply has been switched on.
Off	The electricity supply has been switched off, or the pump has been cut out by the thermal overload switch.

Three-phase pumps

Three-phase pumps have a green and a red indicator light:

Indicator lights		Description
Green	Red	
Off	Off	The electricity supply has been switched off, or the pump has been cut out by the thermal overload switch.
On	Off	The electricity supply has been switched on.
On	On	The electricity supply has been switched on. The direction of rotation is wrong.

Frequency converter operation

All 3 x 460 V, 3 x 575 V and 3-speed 3 x 208-230 V pumps with standard module are suitable for frequency converter applications. Please note the following:

- Even if the red indicator light is on, the pump is operating normally.
- Pumps fitted with other modules than the standard module must not be connected to a frequency converter.
- Depending on the frequency converter type, this may cause increased acoustic noise from the motor. Furthermore, it may cause the motor to be exposed to detrimental voltage peaks.
- The motor must be protected against voltage peaks higher than 650 V between the motor terminals.

Acoustic noise and detrimental voltage peaks can be reduced by fitting an LC filter between the frequency converter and the motor.

Pumps with protection module

The protection module is standard for single-phase pumps and available for 3 x 208-230V models only as an option.

When fitted with a protection module, the pump can be connected directly to a mains switch as it will be protected by the built-in overload protection.

The protection module incorporates two indicator lights.

Protection module indicator lights

Indicator lights		Description
Green	Red	
Off	Off	The pump has been stopped. The electricity supply has been switched off.
On	Off	The pump is operating.
On	On	Three-phase pumps only: The pump is operating, but the direction of rotation is wrong.
Off	On	The pump has been cut out by the thermal overload switch.

Note: Pumps with protection module must not be connected to a frequency converter.

Pumps with relay module

The relay module is available for UPS pumps as an option for 1 x 115/230 V and 3 x 208-230 V units.

The module enables direct connection of the pump to an external mains switch. Furthermore, the module has a signal output for external operating or fault indication. By means of a selector switch the output can be set to activation during operation or fault.

The pump is connected directly to the mains as the pump incorporates overload protection at all three speeds.

Note: Pumps with relay module must not be connected to a frequency converter.

If the pump has been cut out by the thermal overload switch, it will restart automatically when it has cooled to normal temperature, provided the external on/off contact is closed.

Note: If the thermal overload switch has cut out the pump three times within a short time, the relay must be reset manually by switching off the electricity supply.

Relay module indicator lights

The relay module indicator lights provides detailed operating and fault indications.

All pumps with relay module incorporate a green and a red indicator light. Functions, see table in Signal output of relay module.

Signal output of relay module

The relay module has a signal output for external operating or fault indication.

By means of the selector switch, the signal output can be set to activation during operation or fault.



Operation: The output functions as operating indication between terminals 2 and 3.



Fault: The output functions as fault indication between terminals 1 and 3.

Indicator lights		Signal output set to		Description
Green	Red	Operation	Fault	
Off	Off			The pump has been stopped. The electricity supply has been switched off, or a phase is missing.
On	Off			The pump is operating.
On	On			Only three-phase pumps: The pump is operating, but with wrong direction of rotation.
Off	On			The pump has been cut out by the thermal overload switch.
Flashing	Off			The pump has been stopped by an external on/off switch.
Flashing	On			The pump is or has been cut out by the thermal overload switch, and it has been stopped by an external on/off switch.

Operating modes of two pumps plumbed in parallel

Both pumps must be fitted with a relay module.

In addition to the signal functions, the signal output of the relay module for two pumps in parallel can be used for controlling the operating mode of pump 1 and 2.

It is possible to choose between three operating modes:

1. **Alternating operation.** The pumps operate alternately as duty and standby pump, respectively. Changeover takes place every 24 hours. If the duty pump is cut out due to a fault, the standby pump will automatically start. During changeover both pumps will be running for a short period to ensure a low-noise changeover.
2. **Standby operation.** The pumps operate continuously as duty and standby pump, respectively. If the duty pump is cut out due to a fault, the standby pump will automatically start at a signal from the output of the duty pump. The sequence can be changed to make the standby pump operate as duty pump.
3. **Single-pump operation.** The pumps run independently without communicating with each other.

VersaFlo UPS

Model	Cast iron Product no.	Bronze Product no.	Max. HP Speed 3	PH	Voltage	Speed	Max. RPM	HMAX. AMPS	P-MAX. Watts	Istart AMPS
UPS 32-40/4	96402694	96402699	1/3	1	115	3	1712	1.08	120	2.10
						2	1667	1.04	100	2.02
						1	1594	0.95	85	1.85
						3	1712	0.54	120	1.00
						2	1667	0.52	100	0.96
						1	1594	0.47	85	0.87
	96402695	96402700	1/3	3	208-230	3	1721	0.56	115	1.60
						2	1580	0.26	75	0.74
						1	1496	0.24	65	0.69
						2	1721	0.28	115	0.82
						1	1580	0.13	75	0.38
						2	1721	0.22	115	0.66
UPS 32-80/2	96402696	96402701	1/2	3	460	2	1721	0.22	115	0.66
						1	1580	0.10	75	0.30
						3	3495	2.66	120	2.10
						2	3400	2.50	100	2.02
						1	3281	2.50	85	1.85
						3	3495	1.34	120	1.00
	96402697	96402702	1/2	3	230	2	3400	1.26	100	0.96
						1	3281	1.26	85	0.87
						3	3495	0.56	115	1.60
						2	3269	0.26	75	0.74
						1	3194	0.24	65	0.69
						2	3495	0.55	115	0.82
UPS 32-160/2	96402698	96402703	3/4	3	575★	2	3495	0.44	115	0.66
						1	3269	0.29	75	0.30
						3	3477	5.80	625	14.60
						2	3399	5.80	600	14.60
						1	3281	5.50	555	13.84
						3	3477	2.90	625	6.70
	96402708	96402713	3/4	3	230	2	3399	2.90	600	6.70
						1	3281	2.75	555	6.35
						3	3487	1.96	600	9.30
						2	3292	1.25	430	5.93
						1	3201	1.12	380	5.31
						2	3487	0.98	600	4.70
96402709	96402714	3/4	3	460	1	3292	0.63	430	3.02	
					2	3487	0.78	600	3.76	
					2	3487	0.78	600	3.76	
					1	3292	0.50	430	2.40	
					2	3487	0.78	600	3.76	
					1	3292	0.50	430	2.40	

Note: 3-phase, 460 V and 575 V models are 2-speed only.

★ Canada only

Product data

VersaFlo® UP, UPS

Model	Cast iron Product no.	Bronze Product no.	Max. HP Speed 3	PH	Voltage	Speed	Max. RPM	HMAX. AMPS	P-MAX. Watts	Istart AMPS
UPS 40-40/4	96402748	96402753	1/3	1	115	3	1711	1.60	170	3.10
						2	1654	1.48	150	2.87
						1	1575	1.34	125	2.60
	96402749	96402754			230	3	1711	0.80	170	1.50
						2	1654	0.74	150	1.39
						1	1575	0.66	125	1.24
	96402750	96402755	3	208-230	3	1720	0.88	260	2.50	
					2	1561	0.42	120	1.19	
					1	1512	0.36	100	1.02	
	96402751	96402756			460	2	1720	0.44	260	1.30
						1	1561	0.21	120	0.62
						2	1720	0.33	186	1.04
96402752	96402757	575★	1	1561	0.17	120	0.50			
UPS 40-80/4	96404948	96404953	1/2	1	115	3	1688	5.50	565	9.50
						2	1587	5.15	485	8.90
						1	1450	4.30	410	7.43
	96404949	96404954			230	3	1688	2.75	565	4.70
						2	1587	2.60	485	4.44
						1	1450	2.15	410	3.67
	96404950	96404955	3	208-230	3	1708	1.98	550	7.10	
					2	1640	1.20	370	4.30	
					1	1584	1.00	305	3.59	
	96404951	96404956			460	2	1708	0.99	550	4.70
						1	1640	0.60	370	4.44
						2	1708	0.78	550	3.76
96404952	96404957	575★	1	1640	0.48	370	3.55			
UPS 40-80/2	96402762	96402767	3/4	1	115	3	3455	4.45	480	11.00
						2	3321	4.40	450	10.88
						1	3194	4.40	440	10.88
	96402763	96402768			230	3	3455	2.24	480	5.60
						2	3321	2.20	450	5.50
						1	3194	2.18	440	5.45
	96402764	96402769	3	208-230	3	3432	1.45	440	7.40	
					2	3126	0.94	320	4.80	
					1	2984	0.86	290	4.39	
	96402765	96402770			460	2	3432	0.73	440	3.70
						1	3126	0.47	320	2.38
						2	3432	0.58	440	2.96
96402766	96402771	575★	1	3126	0.38	320	1.90			

Note: 3-phase, 460 V and 575 V models are 2-speed only.

★ Canada only

Product data

VersaFlo® UP, UPS

Model	Cast iron Product no.	Bronze Product no.	Max. HP Speed 3	PH	Voltage	Speed	Max. RPM	HMAX. AMPS	P-MAX. Watts	Istart AMPS	
UPS 40-160/2	96402782	96402787	3/4	1	115	3	3447	8.40	890	18.60	
						2	3332	7.45	760	16.50	
						1	3162	6.95	690	15.39	
	96402783	96402788			230	3	3463	4.20	890	9.30	
						2	3202	3.75	760	8.30	
						1	3055	3.45	690	7.64	
	96402784	96402789	208-230	3	3	3463	2.50	800	12.40		
					2	3202	1.75	570	8.68		
					1	3055	1.55	500	7.69		
	96402785	96402790			460	3	2	3463	1.25	800	6.20
							1	3202	0.88	570	4.36
							2	3463	1.00	800	4.96
96402786	96402791	575★	1	3202	0.70	570	3.50				
UPS 40-240/2	96402797	96402804	1-½	1	230	3	3412	6.20	1350	11.80	
						2	3322	5.55	1200	10.56	
						1	3196	5.15	1100	9.80	
	96402798	96402805			208-230	3	3	3524	4.50	1440	23.80
							2	3388	3.25	1100	17.19
							1	3312	2.95	990	15.60
	96402799	96402807	460	3	2	3524	2.25	1440	11.60		
					1	3388	1.63	1100	8.40		
					2	3524	1.80	1440	9.28		
	96402801	96402809	575★	1	3388	1.30	1100	6.72			
	UPS 50-40/4	96402814	96402819	1/3	1	115	3	1714	2.66	285	5.20
							2	1659	2.60	244	5.08
1							1593	2.20	204	4.30	
96402815		96402820	230			3	3	1714	1.32	285	2.60
							2	1659	1.30	244	2.56
							1	1593	1.10	204	2.17
96402816		96402821	208-230	3	3	1733	1.40	270	4.60		
					2	1615	0.66	170	2.17		
					1	1555	0.54	150	1.77		
96402817		96402822	460	3	2	1733	0.70	270	2.30		
					1	1615	0.33	170	1.08		
					2	1733	0.56	270	1.84		
96402818	96402823	575★	1	1615	0.26	170	0.86				
UPS 50-80/4	96404958	96404963	3/4	1	115	3	1694	7.55	720	13.20	
						2	1607	6.85	620	11.98	
						1	1491	5.15	480	9.00	
	96404959	96404964			230	3	3	1747	3.80	720	6.50
							2	1643	3.40	620	5.82
							1	1586	2.60	480	4.45
	96404960	96404965	208-230	3	3	1747	2.44	640	8.50		
					2	1643	1.44	450	5.02		
					1	1586	1.24	390	4.32		
	96404961	96404966	460	3	2	1747	1.22	640	4.30		
					1	1643	0.72	450	2.54		
					2	1747	0.98	640	3.44		
96404962	96404967	575★	1	1643	0.58	450	2.00				

Note: 3-phase, 460 V and 575 V models are 2-speed only.

★ Canada only

Product data

VersaFlo® UP, UPS

Model	Cast iron Product no.	Bronze Product no.	Max. HP Speed 3	PH	Voltage	Speed	Max. RPM	HMAX. AMPS	P-MAX. Watts	Istart AMPS					
UPS 50-80/2	96402834	96402843	3/4	1	115	3	3426	5.85	630	14.60					
						2	3282	5.70	610	14.23					
						1	3050	5.80	600	14.48					
						3	3426	2.95	630	7.30					
						2	3282	2.85	610	7.05					
						1	3050	2.90	600	7.18					
	96402836	96402844	3/4	1	230	3	3428	1.92	610	9.30					
						2	3010	1.20	440	5.81					
						1	2872	1.08	400	5.23					
						3	3428	0.96	610	4.70					
						2	3010	0.60	440	2.94					
						1	3010	0.48	440	2.40					
UPS 50-160/2	96411613	96411614	1-½	1	230	3	3395	5.80	1250	26.50					
						2	3294	5.20	1100	23.76					
						1	3144	4.85	1050	22.16					
						3	3395	4.00	1300	22.80					
						2	3294	3.00	1000	17.10					
						1	3144	2.75	950	15.68					
	96402860	96402866	1-½	3	460	2	3509	2.00	1300	11.40					
						1	3339	1.50	1000	8.55					
						2	3509	1.60	1300	9.12					
						1	3339	1.20	1000	6.84					
						96402862	96402870	1-½	3	208-230	3	3496	5.30	1700	31.00
											2	3296	3.95	1300	23.10
1	3186	3.50	1150	20.47											
2	3496	2.65	1700	15.40											
1	3296	1.98	1300	11.51											
2	3496	2.12	1700	12.32											
UPS 50-240/2	96402882	96402885	2	3	460	2	3496	2.12	1700	12.32					
						1	3296	1.68	1300	9.21					
						96402883	96402886	2	3	575 ★	3	3426	5.85	630	14.60
											2	3282	5.70	610	14.23
											1	3050	5.80	600	14.48
											3	3426	2.95	630	7.30
2	3282	2.85	610	7.05											
1	3050	2.90	600	7.18											
UPS 53-55/57	96654373	96654392	3/4	1	230	3	3428	1.92	610	9.30					
						2	3010	1.20	440	5.81					
						1	2872	1.08	400	5.23					
						3	3428	0.96	610	4.70					
						2	3010	0.60	440	2.94					
						1	3010	0.48	440	2.40					
96654374	96654393	3/4	1	115	3	3426	5.85	630	14.60						
					2	3282	5.70	610	14.23						
					1	3050	5.80	600	14.48						
					3	3426	2.95	630	7.30						
					2	3282	2.85	610	7.05						
					1	3050	2.90	600	7.18						
96654375	96654394	3/4	1	230	3	3428	1.92	610	9.30						
					2	3010	1.20	440	5.81						
					1	2872	1.08	400	5.23						
					3	3428	0.96	610	4.70						
					2	3010	0.60	440	2.94						
					1	3010	0.48	440	2.40						
96654376	96654395	3/4	3	460	2	3428	0.96	610	4.70						
					1	3010	0.60	440	2.94						
					2	3428	0.77	610	3.76						
					1	3010	0.48	440	2.40						
					96654377	96654396	3/4	3	575 ★	2	3428	0.77	610	3.76	
										1	3010	0.48	440	2.40	

Note: 3-phase, 460 V and 575 V models are 2-speed only.

★ Canada only

Model	Cast iron Product no.	Bronze Product no.	Max. HP Speed 3	PH	Voltage	Speed	Max. RPM	HMAX. AMPS	P-MAX. Watts	Istart AMPS
UPS 75-69	96654378	96654397	1		230	3	3395	5.80	1250	26.50
						2	3294	5.20	1100	23.76
						1	3144	4.85	1050	22.16
	96654379	96654398	1-½		208-230	3	3395	4.00	1300	22.80
						2	3294	3.00	1000	17.10
						1	3144	2.75	950	15.68
	96654390	96654399	3		460	2	3509	2.00	1300	11.40
						1	3339	1.50	1000	8.55
						2	3509	1.60	1300	9.12
	96654391	96654400			575 ★	2	3339	1.20	1000	6.84
						1	3339	1.20	1000	6.84
						3	1733	1.62	380	7.10
UPS 80-40/4	96402894	96402899	1/2	3	208-230	2	1546	0.87	260	3.81
						1	1439	0.77	230	3.37
						2	1733	0.81	380	3.50
	96402895	96402900			460	1	1546	0.44	260	1.90
						2	1733	0.65	380	2.80
						1	1546	0.35	260	1.52
96402896	96402901			575 ★	2	1733	0.65	380	2.80	
					1	1546	0.35	260	1.52	
					3	1729	3.60	1050	11.80	
UPS 80-80/4	96402908	96402913	1-½	3	208-230	2	1598	2.08	660	6.82
						1	1536	1.72	550	5.64
						3	3513	6.35	2050	31.00
UPS 80-160/2	96402920	96402923	3	3	208-230	2	3351	4.20	1550	20.50
						1	3270	4.05	1500	19.77
						2	3513	3.13	2050	15.40
	96402921	96402924			460	1	3351	2.10	1550	10.17
						2	3513	2.54	2050	12.32
						1	3351	1.68	1550	8.14
96402922	96402925			575 ★	2	3513	2.54	2050	12.32	
					1	3351	1.68	1550	8.14	
					3	1712	2.50	570	10.80	
UPS 100-40/4	96402934	96402937	1	3	208-230	2	1520	1.38	435	5.96
						1	1433	1.24	390	5.36
						2	1712	1.24	670	5.40
	96402935	96402938			460	1	1520	0.70	435	3.05
						2	1712	1.00	570	4.32
						1	1520	0.55	435	2.44
96402936	96401961			575 ★	2	1712	1.00	570	4.32	
					1	1520	0.55	435	2.44	

Note: 3-phase, 460 V and 575 V models are 2-speed only.

★ Canada only

VersaFlo UP

Pump type	Cast iron Product no.	Bronze Product no.	HP	PH	Voltage	I-MAX AMPS	P-MAX AMPS
UP 43-70	96439644		1/2	1	115/230	3.4/1.8	400
UP 43-110	96439643		3/4	1	115/230	4.9/2.5	570
UP 53-45	96633576	96633578	1/2	1	115/230	3.5/1.9	360
UP 53-46	96633591	96633592	3/4	1	115/230	3.9/2.1	420

Performance curves

UPS 32-40/4
1 phase 115 V, 230 V, 60 Hz

UPS

Performance curves

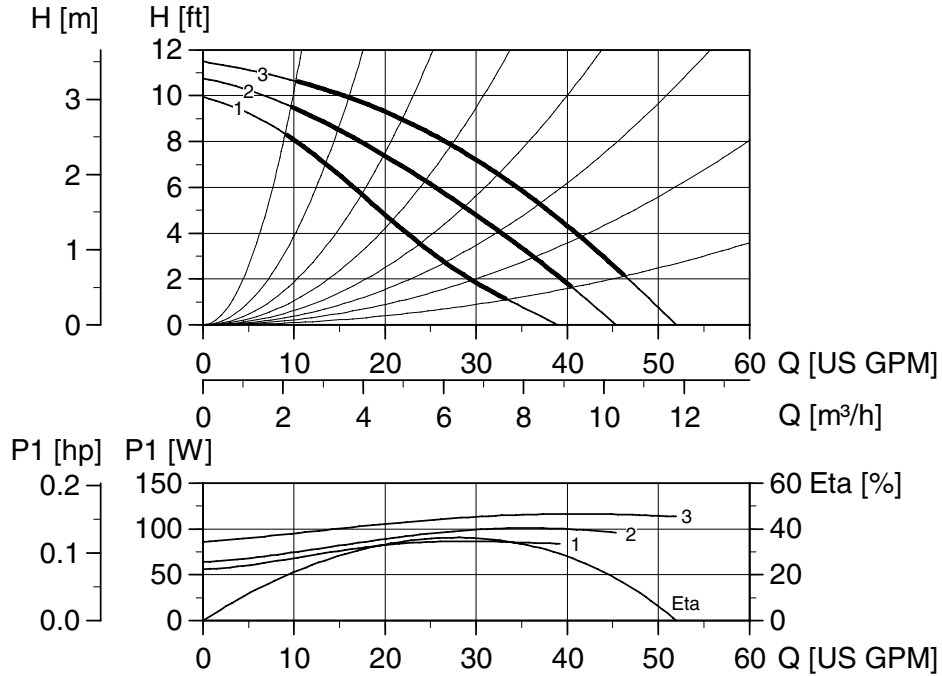

Note: ETA is calculated as wire-to-water efficiency.

Weights and volume

	Cast Iron				Bronze			
	lbs.	ft ³	Kg	m ³	lbs.	ft ³	Kg	m ³
Net weight	35.9		16.3		39.2		17.8	
Gross weight	43.4		19.7		46.7		21.2	
Shipping volume		1.70		0.048		1.70		0.048

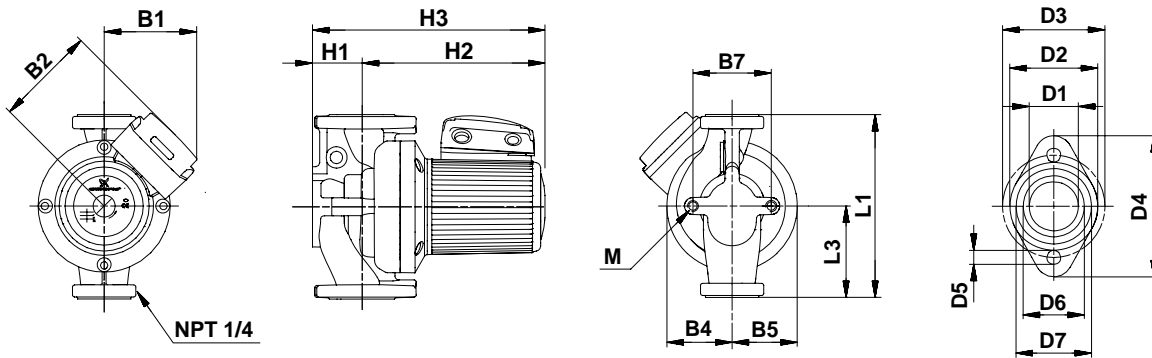

Dimensions

	L1	L3	B1	B2	B4	B5	B7	H1	H2	H3	D1	D2	D3	D4	D5	D6	D7	M
[Inches]	11	5 1/2	5 5/16	5 9/16	3	3	3 3/16	2 11/16	9 1/2	12 3/16	1 7/16	2 9/16	3 1/2	4 5/8	1/2	1 13/16	2 1/4	
[mm]	279.4	139.7	135	141	75	75	80	68	242	310	35.9	64	80	117	12	46	57	M12

Performance curves

UPS 32-40/4
3 phase 208-230 V, 460 V, 575 V ★, 60 Hz

Performance curves

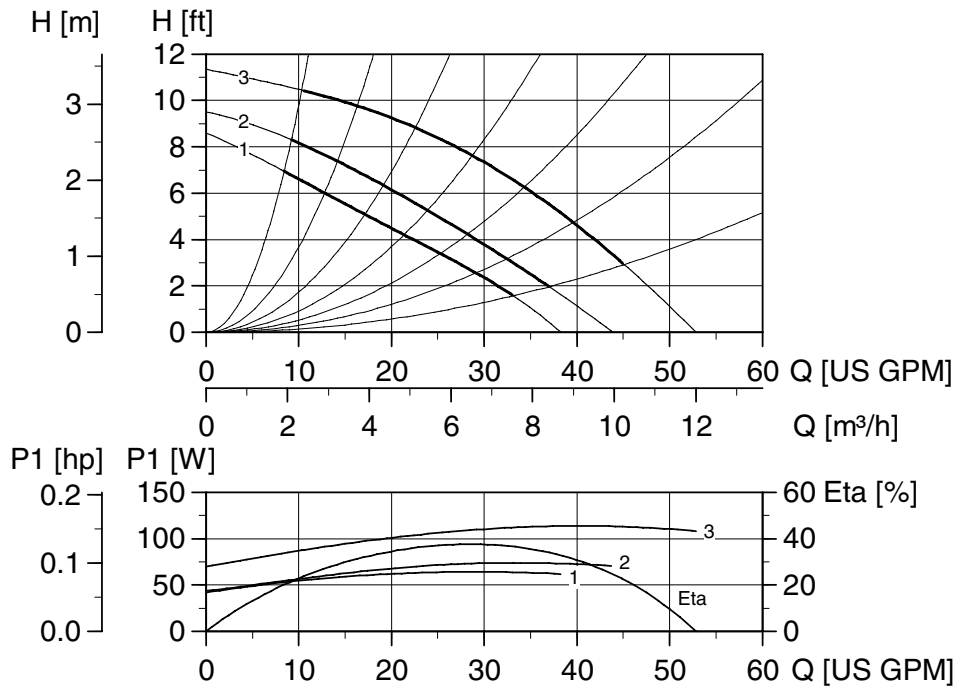

Note: ETA is calculated as wire-to-water efficiency.

Weights and volume

	Cast Iron				Bronze			
	lbs.	ft ³	Kg	m ³	lbs.	ft ³	Kg	m ³
Net weight	35.9		16.3		39.2		17.8	
Gross weight	44.1		20		47.4		21.5	
Shipping volume		1.70		0.048		1.70		0.048

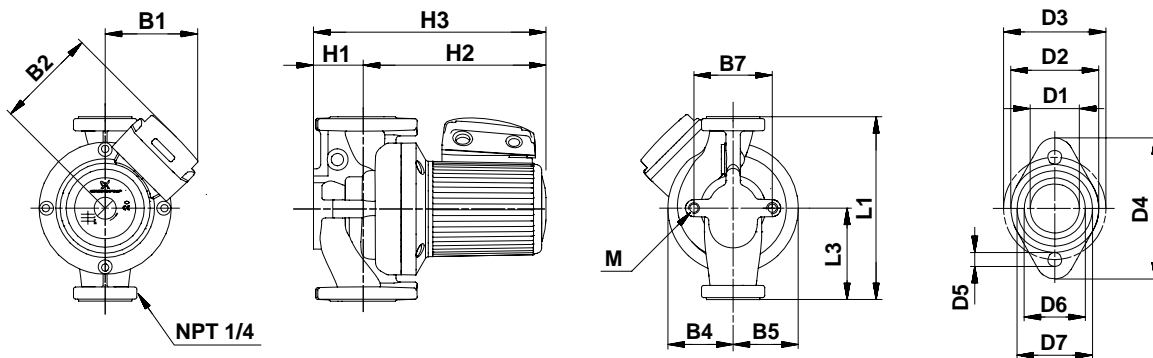

Dimensions

	L1	L3	B1	B2	B4	B5	B7	H1	H2	H3	D1	D2	D3	D4	D5	D6	D7	M
[Inches]	11	5 1/2	5 5/16	5 9/16	3	3	3 3/16	2 11/16	9 1/2	12 3/16	1 7/16	2 9/16	3 1/2	4 5/8	1/2	1 13/16	2 1/4	
[mm]	279.4	139.7	135	141	75	75	80	68	242	310	35.9	64	80	117	12	46	57	M12

★Canada only

Performance curves

UPS 32-80/2
1 phase 115 V, 230 V, 60 Hz

Performance curves

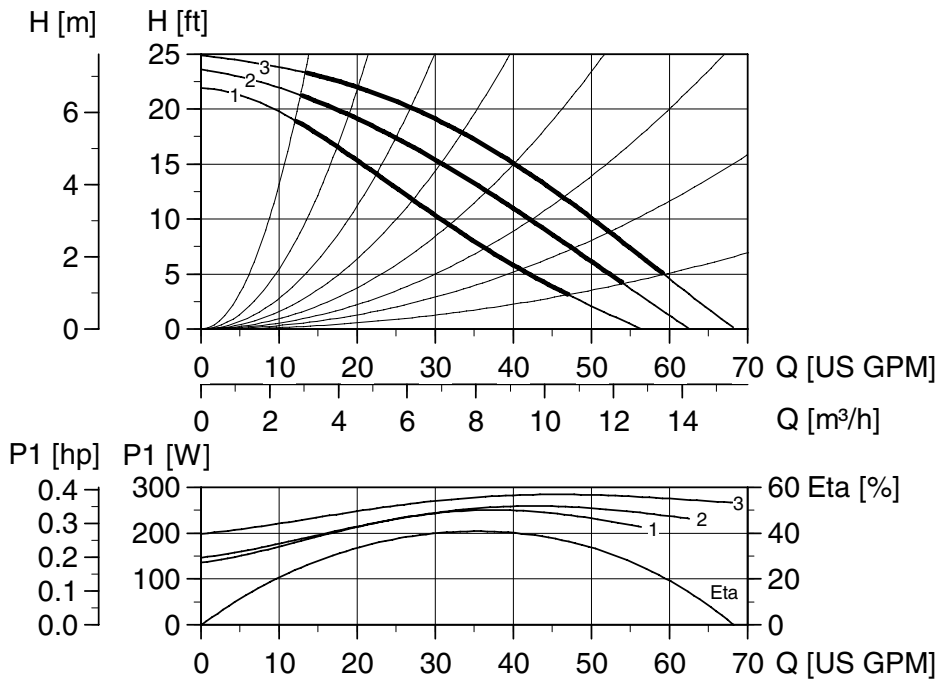

Note: ETA is calculated as wire-to-water efficiency.

Weights and volume

	Cast Iron				Bronze			
	lbs.	ft ³	Kg	m ³	lbs.	ft ³	Kg	m ³
Net weight	35.9		16.3		39.2		17.8	
Gross weight	44.1		20		47.4		21.5	
Shipping volume		1.70		0.048		1.70		0.048

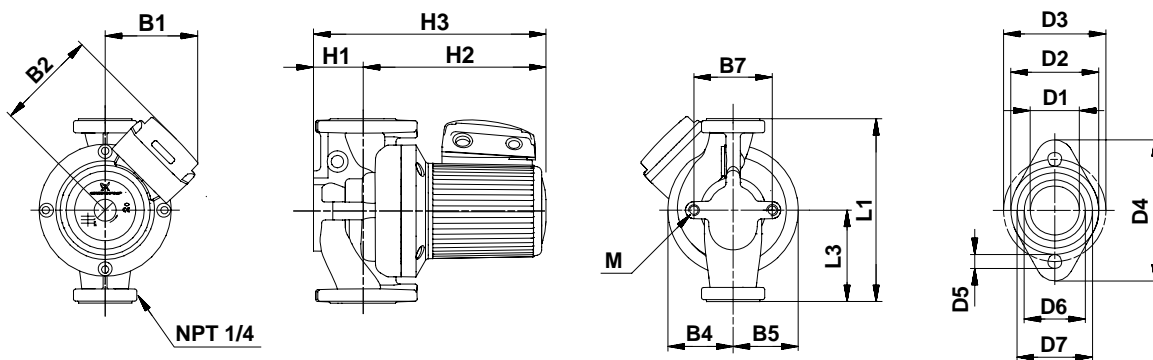

Dimensions

	L1	L3	B1	B2	B4	B5	B7	H1	H2	H3	D1	D2	D3	D4	D5	D6	D7	M
[Inches]	11	5 1/2	5 5/16	5 9/16	3	3	3 3/16	2 11/16	9 7/16	12 1/16	1 7/16	2 9/16	3 7/16	4 5/8	1/2	1 13/16	2 1/4	
[mm]	279.4	139.7	135	141	75	75	80	68	239	307	35.9	64	80	117	12	46	57	M12

Performance curves

UPS 32-80/2
3 phase 208-230 V, 460 V, 575 V ★, 60 Hz

Performance curves

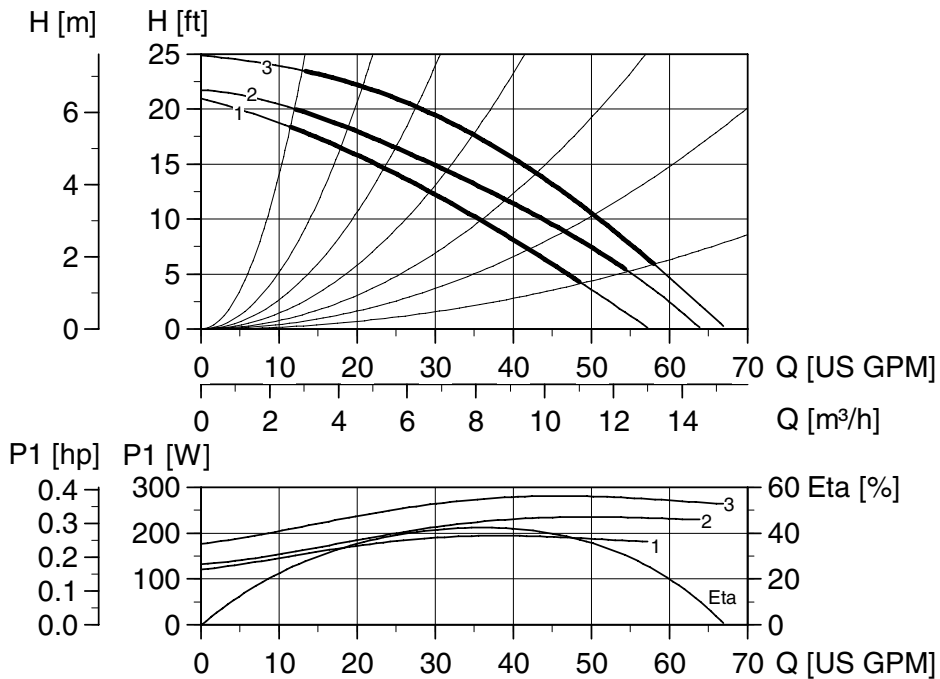

Note: ETA is calculated as wire-to-water efficiency.

Weights and volume

	Cast Iron				Bronze			
	lbs.	ft³	Kg	m³	lbs.	ft³	Kg	m³
Net weight	35.9		16.3		39.2		17.8	
Gross weight	44.1		20		47.4		21.5	
Shipping volume		1.70		0.048		1.70		0.048

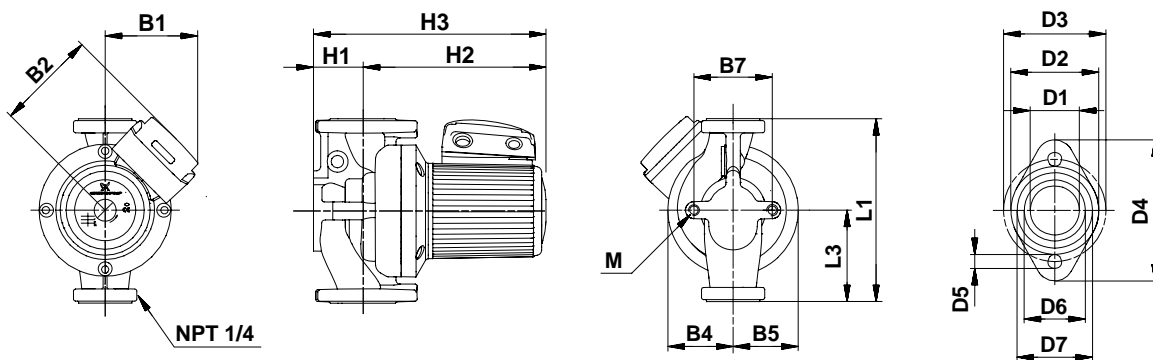

Dimensions

	L1	L3	B1	B2	B4	B5	B7	H1	H2	H3	D1	D2	D3	D4	D5	D6	D7	M
[Inches]	11	5 1/2	5 5/16	5 9/16	3	3	3 3/16	2 11/16	9 7/16	12 1/16	1 7/16	2 9/16	3 7/16	4 5/8	1/2	1 13/16	2 1/4	
[mm]	279.4	139.7	135	141	75	75	80	68	239	307	35.9	64	80	117	12	46	57	M12

★Canada only

Performance curves

UPS 32-160/2
1 phase 115 V, 230 V, 60 Hz

Performance curves

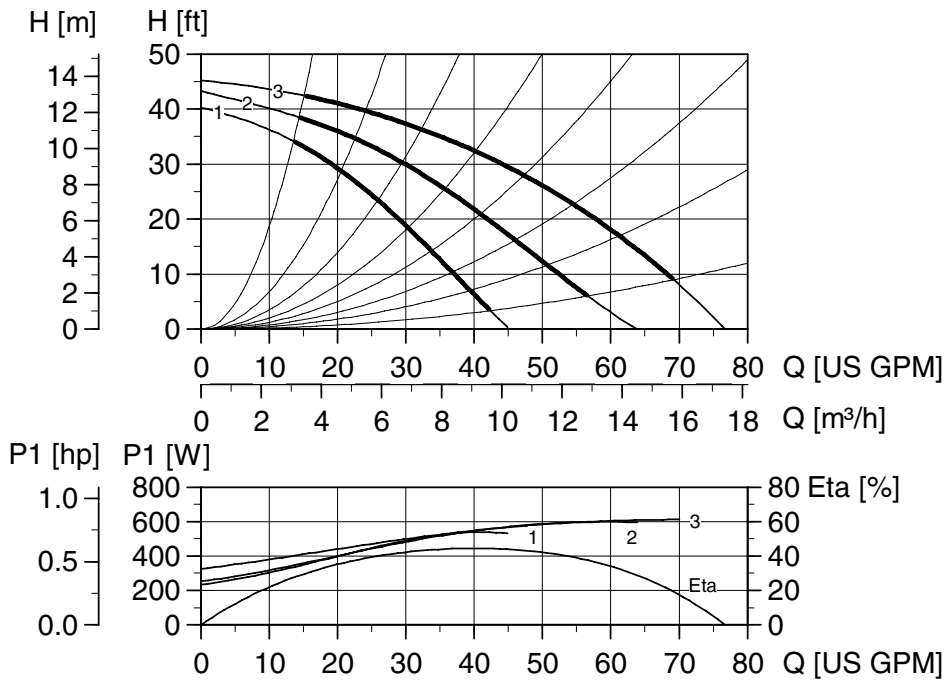

Note: ETA is calculated as wire-to-water efficiency.

Weights and volume

	Cast Iron				Bronze			
	lbs.	ft ³	Kg	m ³	lbs.	ft ³	Kg	m ³
Net weight	37.0		16.8		37.7		17.1	
Gross weight	45.2		20.5		45.9		20.8	
Shipping volume		1.70		0.048		1.70		0.048

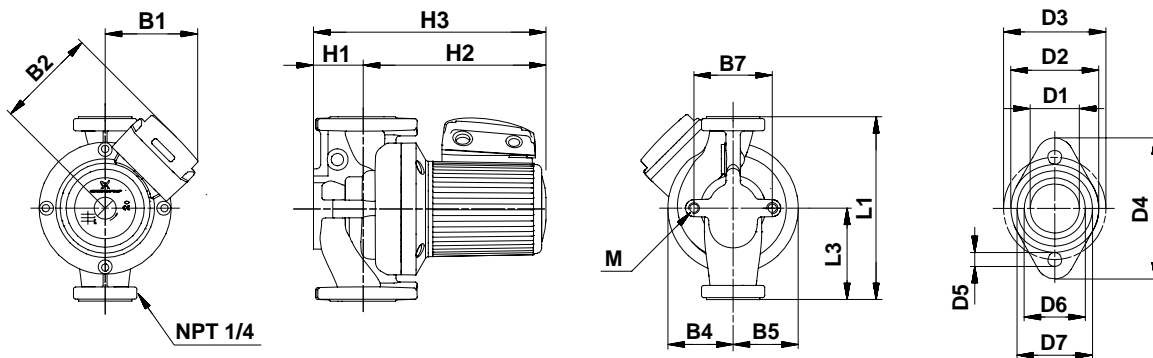

Dimensions

	L1	L3	B1	B2	B4	B5	B7	H1	H2	H3	D1	D2	D3	D4	D5	D6	D7	M
[Inches]	13 1/2	5 1/2	5 5/16	5 9/16	3	3	3 3/16	2 11/16	9 7/16	12 1/8	1 7/16	2 1/2	3 7/16	4 5/8	1/2	2 1/16	2 9/16	
[mm]	343	139.7	135	141	75	75	80	68	240	308	35.9	64	87	117	12	52	64.6	M12

Performance curves

UPS 32-160/2
3 phase 208-230 V, 460 V, 575 V ★, 60 Hz

Performance curves

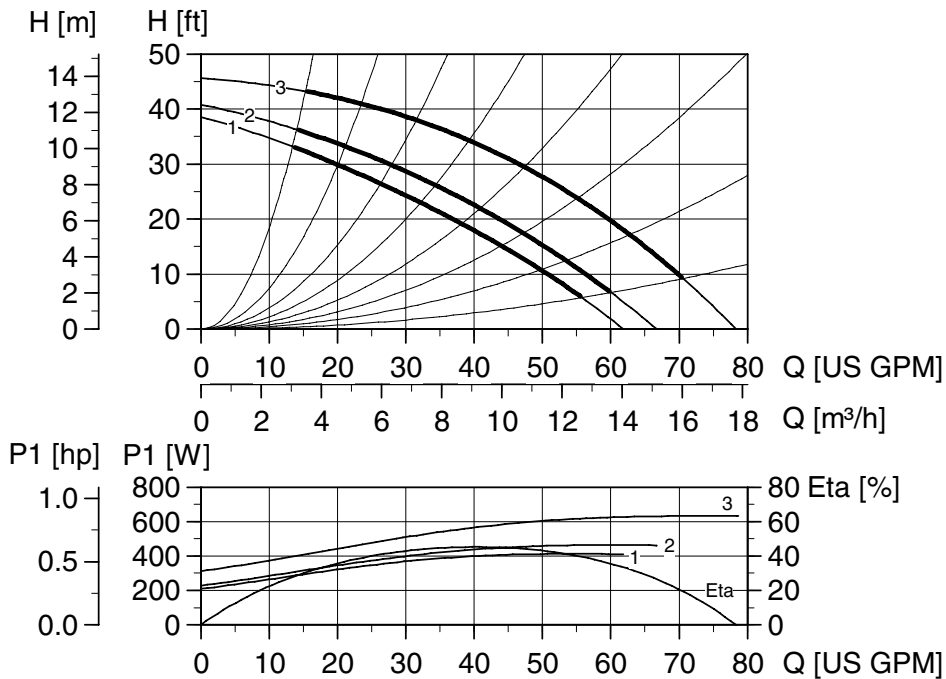

Note: ETA is calculated as wire-to-water efficiency.

Weights and volume

	Cast Iron				Bronze			
	lbs.	ft ³	Kg	m ³	lbs.	ft ³	Kg	m ³
Net weight	36.8		16.7		41.2		18.7	
Gross weight	44.8		20.3		49.4		22.4	
Shipping volume		1.70		0.048		1.70		0.048

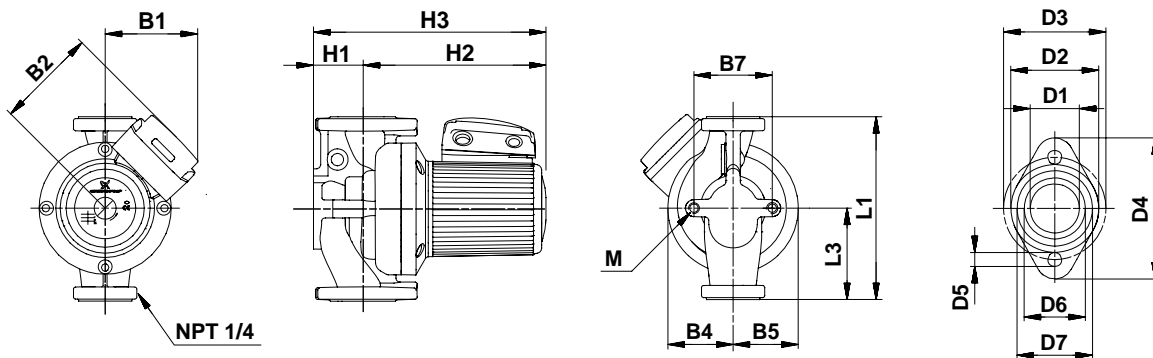

Dimensions

	L1	L3	B1	B2	B4	B5	B7	H1	H2	H3	D1	D2	D3	D4	D5	D6	D7	M
[Inches]	13 1/2	5 1/2	5 5/16	5 9/16	3	3	3 3/16	2 11/16	9 7/16	12 1/8	1 7/16	2 1/2	3 7/16	4 5/8	1/2	2 1/16	2 9/16	
[mm]	343	139.7	135	141	75	75	80	68	240	308	35.9	64	87	117	12	52	64.6	M12

★Canada only

Performance curves

UPS 40-40/4
1 phase 115 V, 230 V, 60 Hz

Performance curves

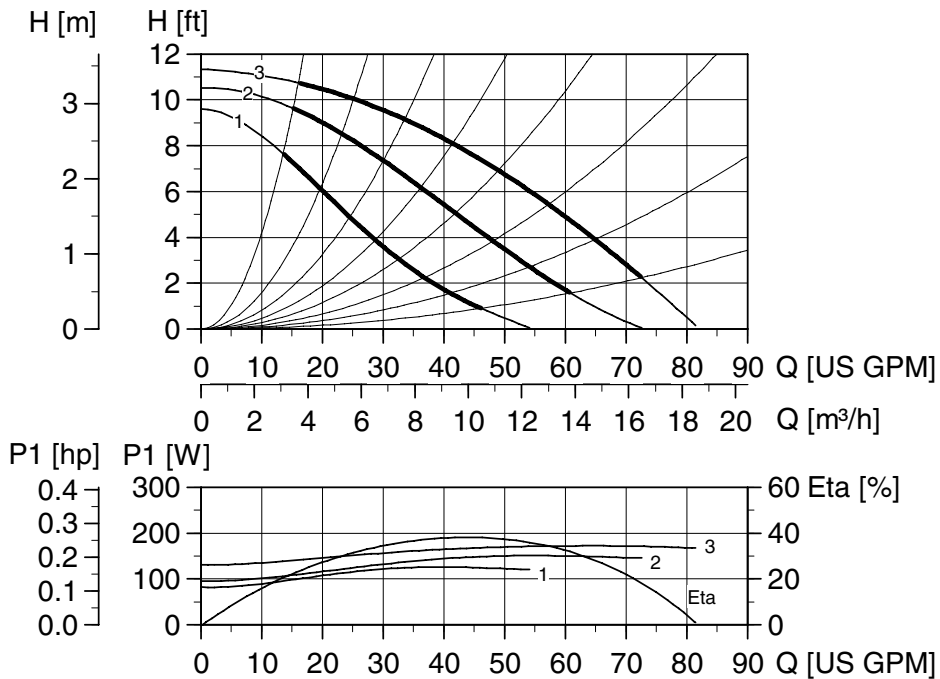

Note: ETA is calculated as wire-to-water efficiency.

Weights and volume

	Cast Iron				Bronze			
	lbs.	ft ³	Kg	m ³	lbs.	ft ³	Kg	m ³
Net weight	37.9		17.2		42.3		19.2	
Gross weight	46.1		20.9		50.5		22.9	
Shipping volume		1.70		0.048		1.70		0.048

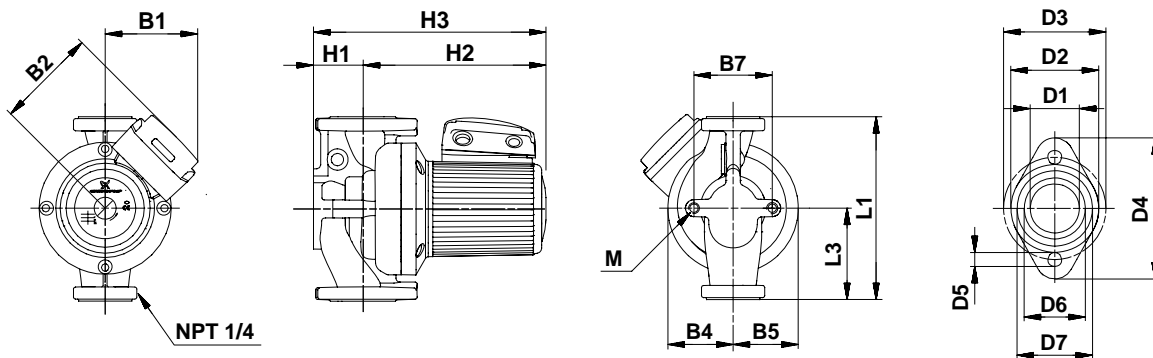

Dimensions

	L1	L3	B1	B2	B4	B5	B7	H1	H2	H3	D1	D2	D3	D4	D5	D6	D7	M
[Inches]	13 1/2	6 3/4	5 5/16	5 9/16	3	3	4 3/4	2 11/16	9 11/16	12 3/8	1 5/8	2 7/8	3 7/16	5	1/2	2 1/16	2 9/16	
[mm]	343	171.5	135	141	85	75	120	68	246	314	41.8	73	87	127	12	52	64.6	M12

Performance curves

UPS 40-40/4
3 phase 208-230 V, 460 V, 575 V ★, 60 Hz

Performance curves

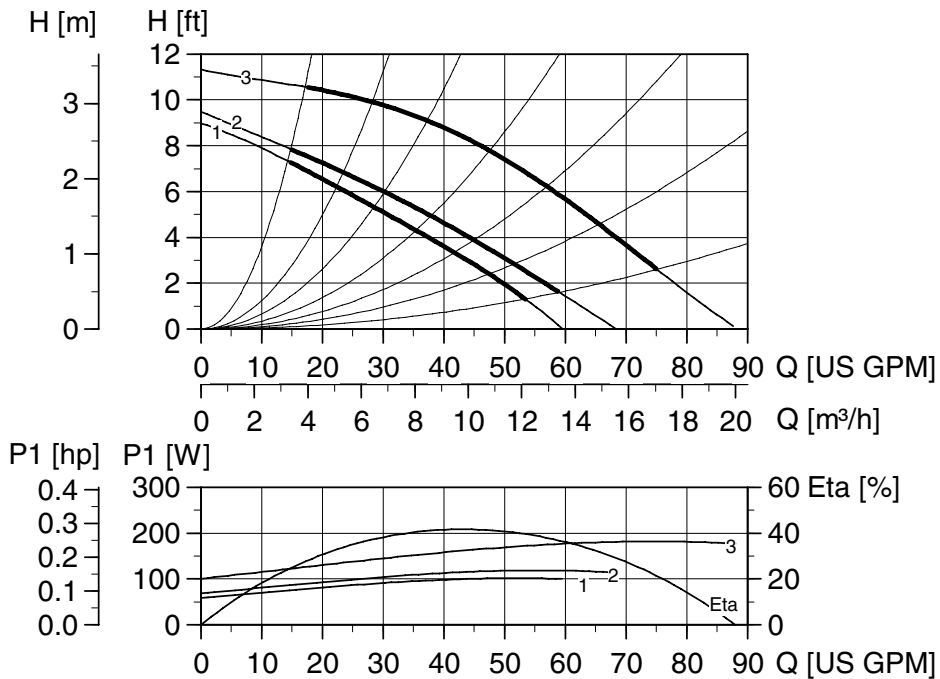

Note: ETA is calculated as wire-to-water efficiency.

Weights and volume

	Cast Iron				Bronze			
	lbs.	ft ³	Kg	m ³	lbs.	ft ³	Kg	m ³
Net weight	37.7		17.1		42.1		19.1	
Gross weight	45.9		20.8		50.3		22.8	
Shipping volume		1.70		0.048		1.70		0.048

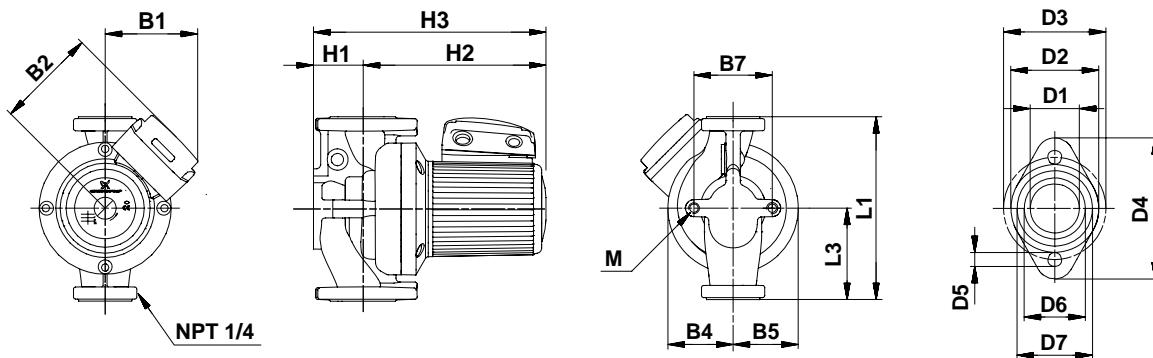

Dimensions

	L1	L3	B1	B2	B4	B5	B7	H1	H2	H3	D1	D2	D3	D4	D5	D6	D7	M
[Inches]	13 1/2	6 3/4	5 5/16	5 9/16	3	3	4 3/4	2 11/16	9 11/16	12 3/8	1 5/8	2 7/8	3 7/16	5	1/2	2 1/16	2 9/16	
[mm]	343	171.5	135	141	85	75	120	68	246	314	41.8	73	87	127	12	52	64.6	M12

★Canada only

Performance curves

UPS 40-80/4
1 phase 115 V, 230 V, 60 Hz

Performance curves

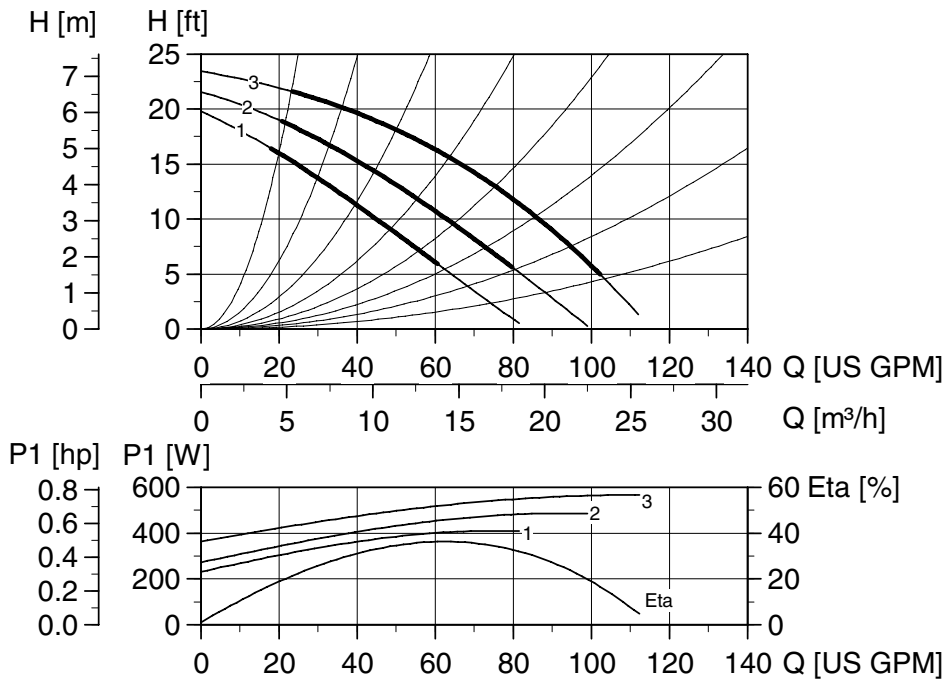

Note: ETA is calculated as wire-to-water efficiency.

Weights and volume

	Cast Iron				Bronze			
	lbs.	ft ³	Kg	m ³	lbs.	ft ³	Kg	m ³
Net weight	57.8		26.2		62.2		28.2	
Gross weight	70.1		31.8		74.5		33.8	
Shipping volume		2.90		0.082		2.90		0.082

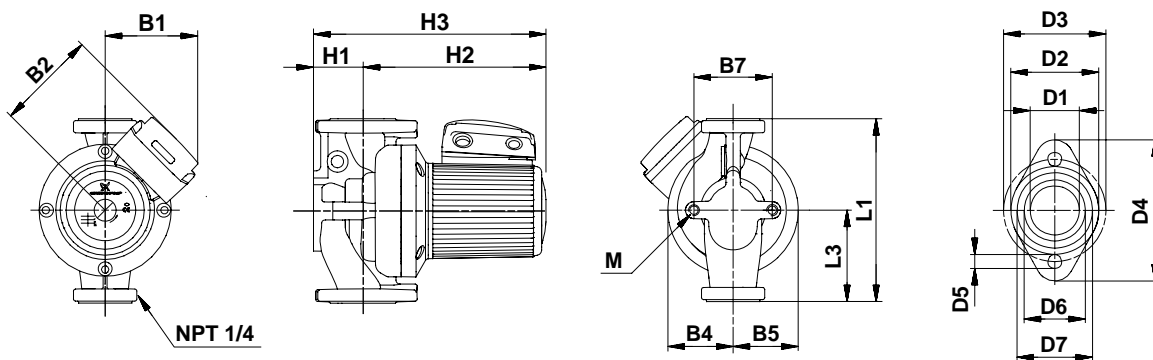

Dimensions

	L1	L3	B1	B2	B4	B5	B7	H1	H2	H3	D1	D2	D3	D4	D5	D6	D7	M
[Inches]	13 1/2	6 3/4	5 3/4	6 5/8	3 15/16	3 15/16	4 3/4	3	9	13 3/16	1 11/16	2 7/8	3 7/16	5	1/2	2 1/16	2 9/16	
[mm]	343	171.5	145	169	100	100	120	75	228	335	41.8	73	87	127	12	52	64.6	M12

Performance curves

UPS 40-80/4
3 phase 208-230 V, 460 V, 575 V ★, 60 Hz

Performance curves

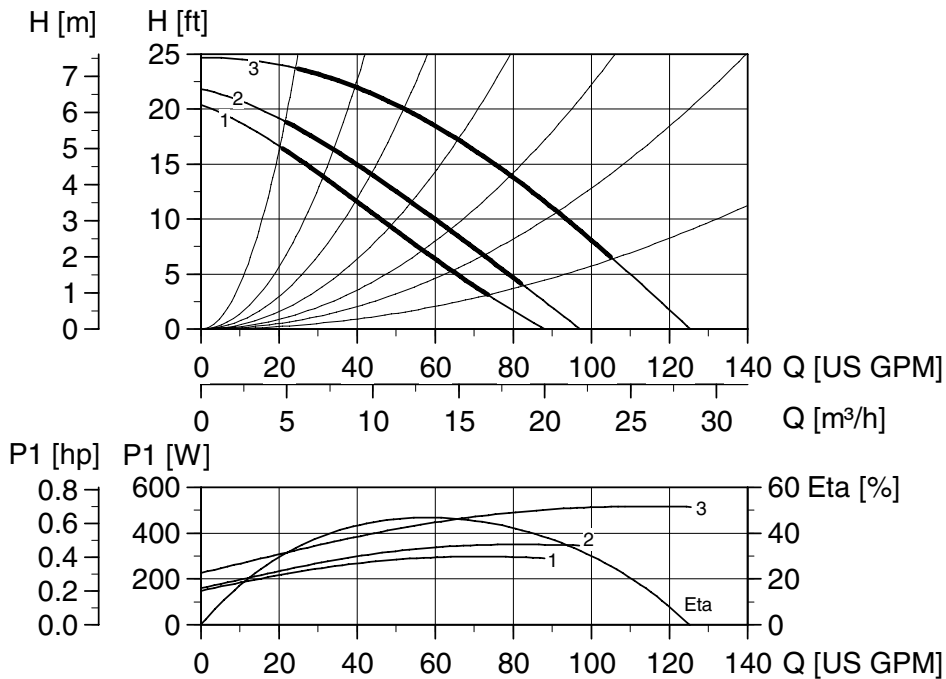

Note: ETA is calculated as wire-to-water efficiency.

Weights and volume

	Cast Iron				Bronze			
	lbs.	ft ³	Kg	m ³	lbs.	ft ³	Kg	m ³
Net weight	47.6		21.6		52.0		23.6	
Gross weight	60.0		27.2		64.4		29.2	
Shipping volume		2.90		0.082		2.90		0.082

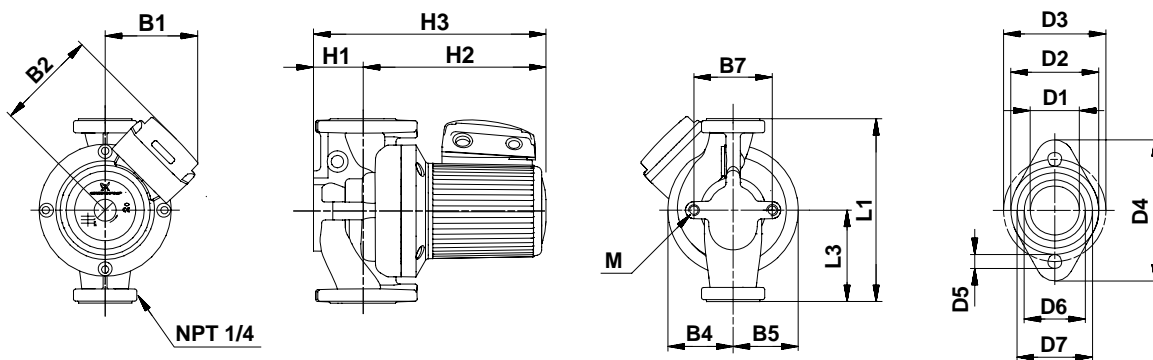

Dimensions

	L1	L3	B1	B2	B4	B5	B7	H1	H2	H3	D1	D2	D3	D4	D5	D6	D7	M
[Inches]	13 1/2	6 3/4	5 3/4	6 5/8	3 15/16	3 15/16	4 3/4	3	9	13 3/16	1 11/16	2 7/8	3 7/16	5	1/2	2 1/16	2 9/16	
[mm]	343	171.5	145	169	100	100	120	75	228	335	41.8	73	87	127	12	52	64.6	M12

★Canada only

Performance curves

UPS 40-80/2
1 phase 115 V, 230 V, 60 Hz

Performance curves

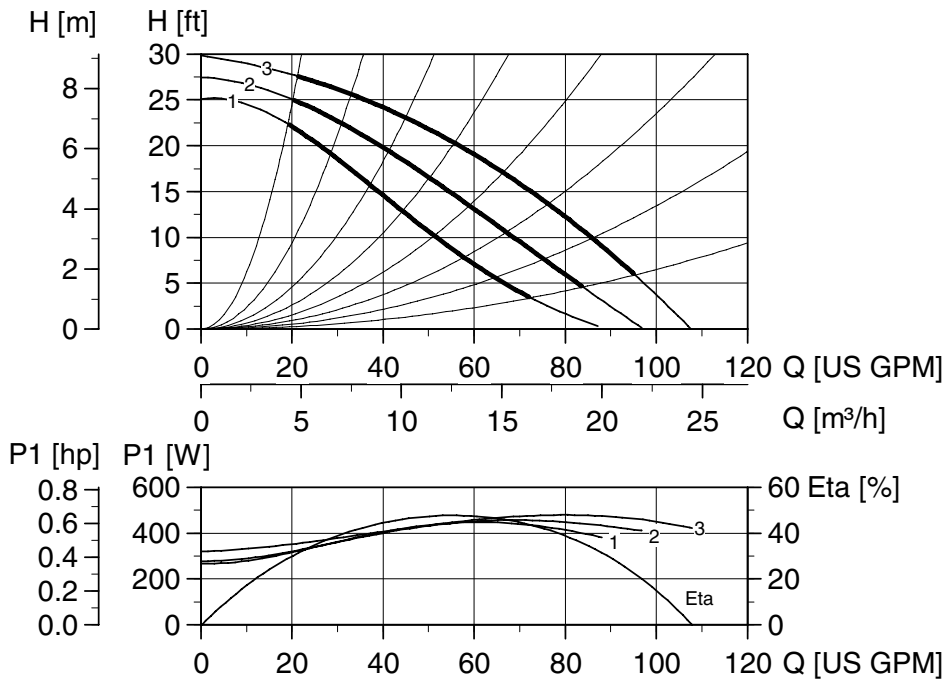

Note: ETA is calculated as wire-to-water efficiency.

Weights and volume

	Cast Iron				Bronze			
	lbs.	ft ³	Kg	m ³	lbs.	ft ³	Kg	m ³
Net weight	38.4		17.4		42.8		19.4	
Gross weight	46.5		21.1		50.9		23.1	
Shipping volume		1.70		0.048		1.70		0.048

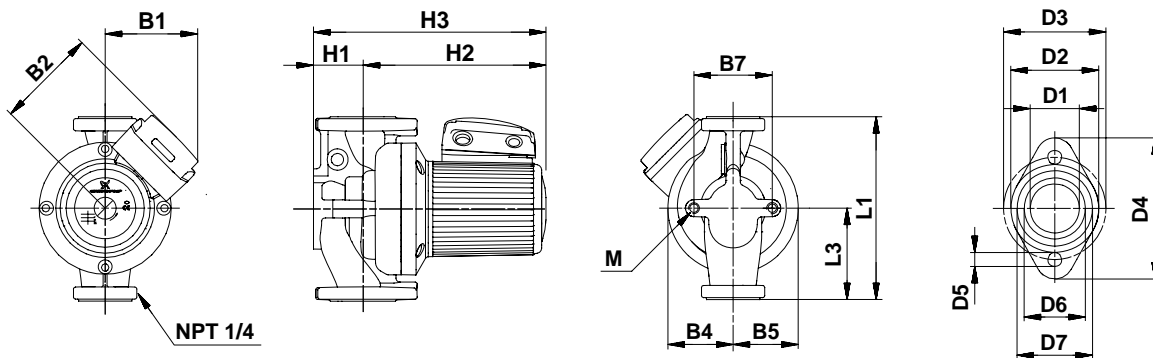

Dimensions

	L1	L3	B1	B2	B4	B5	B7	H1	H2	H3	D1	D2	D3	D4	D5	D6	D7	M
[Inches]	13 1/2	6 3/4	5 5/16	5 9/16	3	3	3 1/8	2 11/16	9 5/8	12 5/16	1 11/16	2 7/8	3 7/16	5	1/2	2 1/16	2 9/16	
[mm]	342.9	171.5	135	141	75	75	80	68	245	315	41.8	73	87	127	12	52	64.6	M12

Performance curves

UPS 40-80/2
3 phase 208-230 V, 460 V, 575 V ★, 60 Hz

Performance curves

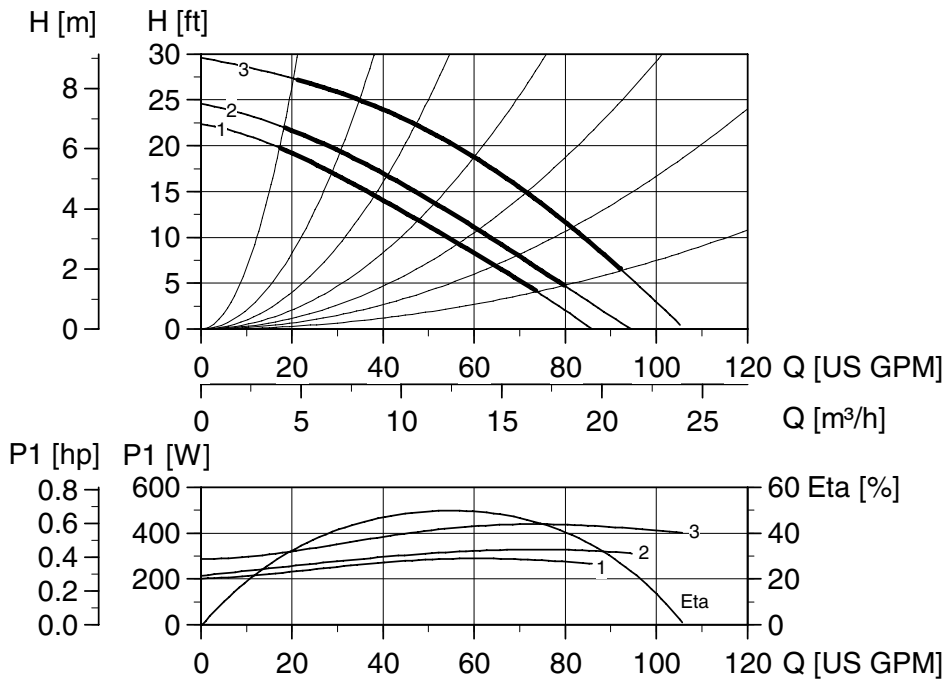

Note: ETA is calculated as wire-to-water efficiency.

Weights and volume

	Cast Iron				Bronze			
	lbs.	ft ³	Kg	m ³	lbs.	ft ³	Kg	m ³
Net weight	38.4		17.4		42.8		19.4	
Gross weight	46.5		21.1		50.9		23.1	
Shipping volume		1.70		0.048		1.70		0.048

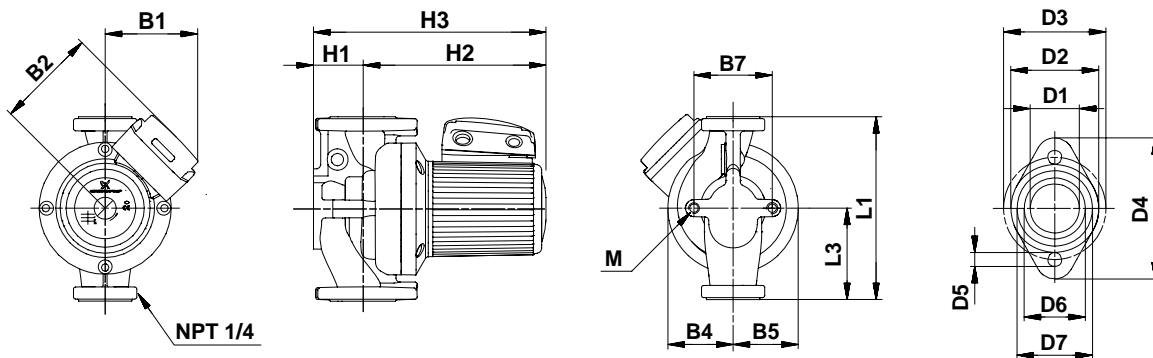

Dimensions

	L1	L3	B1	B2	B4	B5	B7	H1	H2	H3	D1	D2	D3	D4	D5	D6	D7	M
[Inches]	13 1/2	6 3/4	5 5/16	5 9/16	3	3	3 1/8	2 11/16	9 5/8	12 5/16	1 11/16	2 7/8	3 7/16	5	1/2	2 1/16	2 9/16	
[mm]	342.9	171.5	135	141	75	75	80	68	245	315	41.8	73	87	127	12	52	64.6	M12

★Canada only

Performance curves

UPS 40-160/2
1 phase 115 V, 230 V, 60 Hz

Performance curves

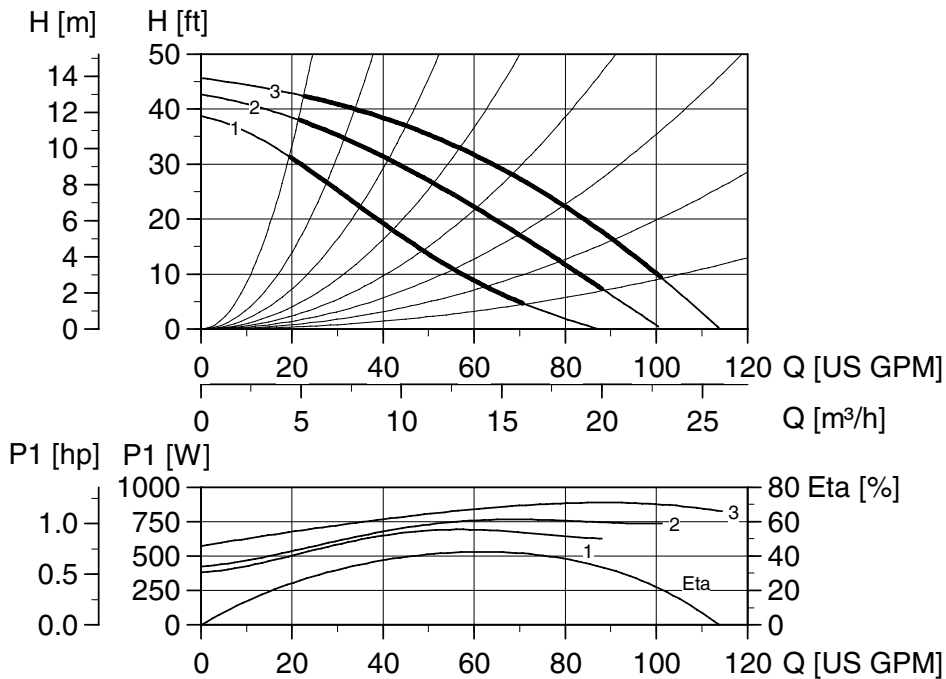

Note: ETA is calculated as wire-to-water efficiency.

Weights and volume

	Cast Iron				Bronze			
	lbs.	ft ³	Kg	m ³	lbs.	ft ³	Kg	m ³
Net weight	43.2		19.6		47.6		21.6	
Gross weight	55.6		25.2		60.0		27.2	
Shipping volume		2.90		0.082		2.90		0.082

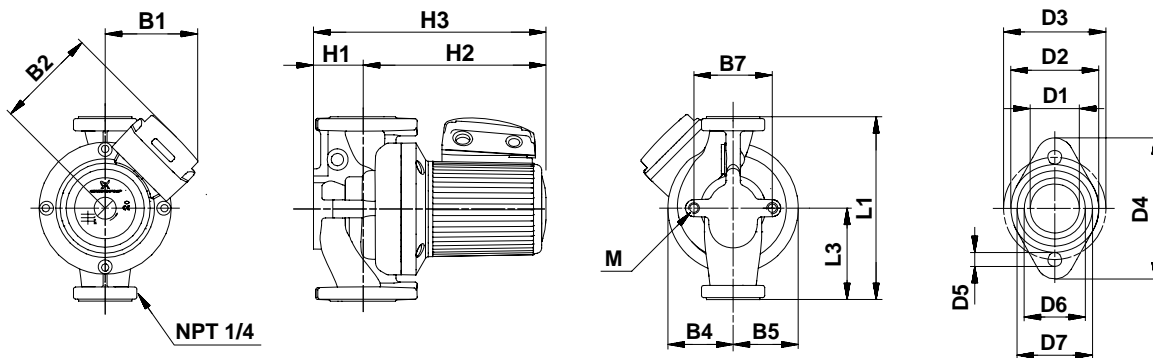

Dimensions

	L1	L3	B1	B2	B4	B5	B7	H1	H2	H3	D1	D2	D3	D4	D5	D6	D7	M
[Inches]	11 1/2	5 3/4	5 3/4	6 5/8	3 15/16	3 15/16	3 3/16	2 15/16	9	11 5/8	1 11/16	2 7/8	3 7/16	5	1/2	2 1/16	2 9/16	
[mm]	292	146	145	169	100	100	80	74	228	296	41.8	73	87	127	12	52	64.6	M12

Performance curves

UPS 40-160/2
3 phase 208-230 V, 460 V, 575 V ★, 60 Hz

Performance curves

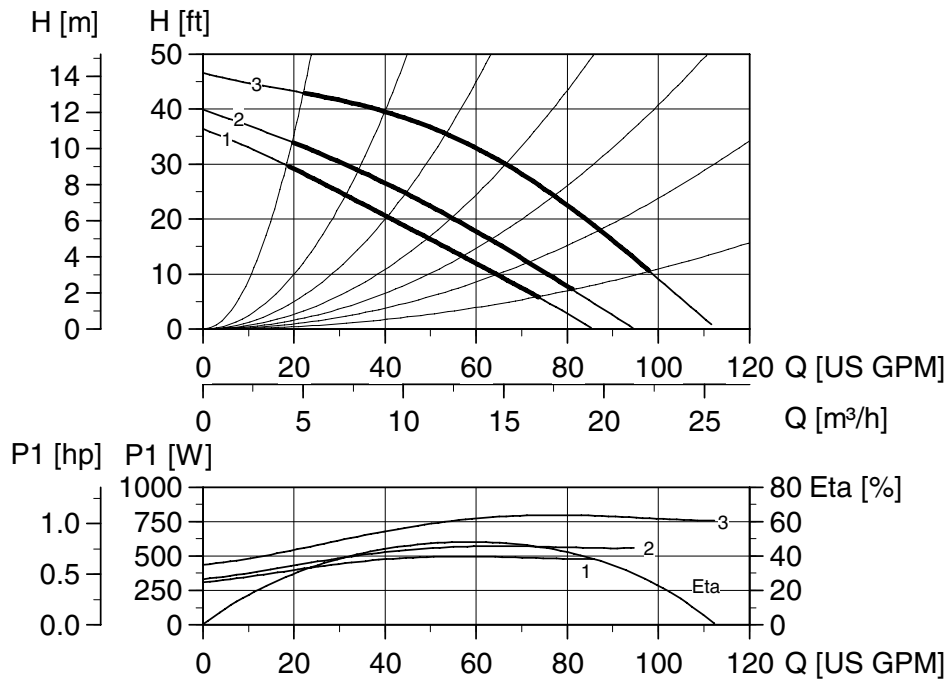

Note: ETA is calculated as wire-to-water efficiency.

Weights and volume

	Cast Iron				Bronze			
	lbs.	ft ³	Kg	m ³	lbs.	ft ³	Kg	m ³
Net weight	43.2		19.6		47.6		21.6	
Gross weight	55.6		25.2		60.0		27.2	
Shipping volume		2.90		0.082		2.90		0.082

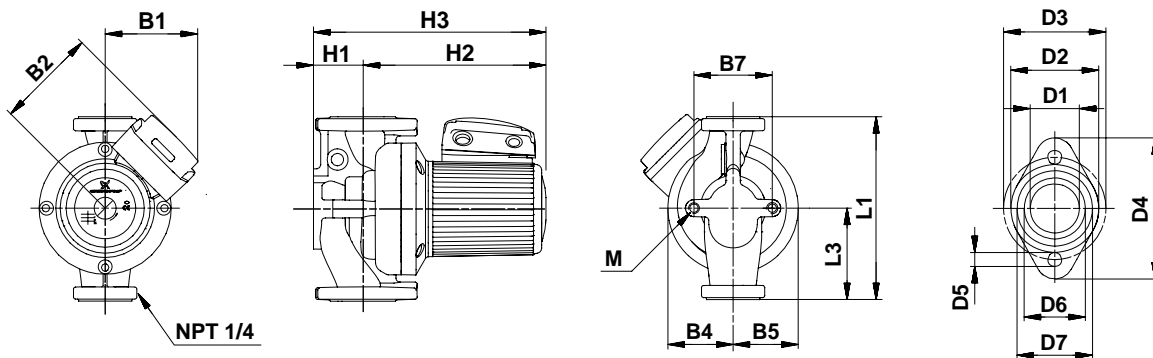

Dimensions

	L1	L3	B1	B2	B4	B5	B7	H1	H2	H3	D1	D2	D3	D4	D5	D6	D7	M
[Inches]	11 1/2	5 3/4	5 3/4	6 5/8	3 15/16	3 15/16	3 3/16	2 15/16	9	11 5/8	1 11/16	2 7/8	3 7/16	5	1/2	2 1/16	2 9/16	
[mm]	292	146	145	169	100	100	80	74	228	296	41.8	73	87	127	12	52	64.6	M12

★Canada only

Performance curves

UPS 40-240/2
1 phase 230 V, 60 Hz

Performance curves

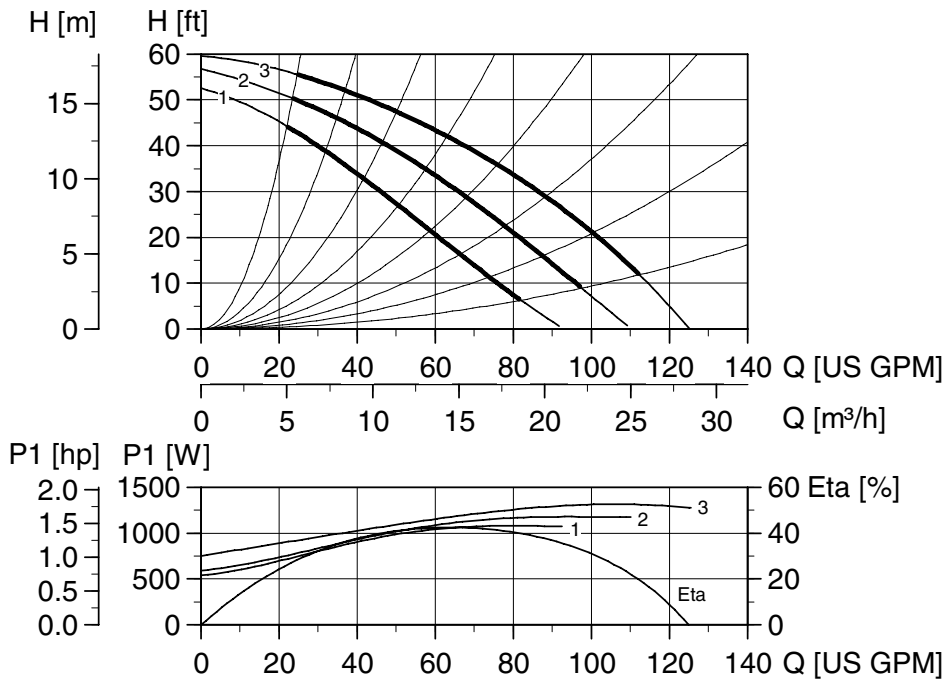

Note: ETA is calculated as wire-to-water efficiency.

Weights and volume

	Cast Iron				Bronze			
	lbs.	ft ³	Kg	m ³	lbs.	ft ³	Kg	m ³
Net weight	54.0		24.5		58.4		26.5	
Gross weight	66.4		30.1		70.8		32.1	
Shipping volume		2.90		0.082		2.90		0.082

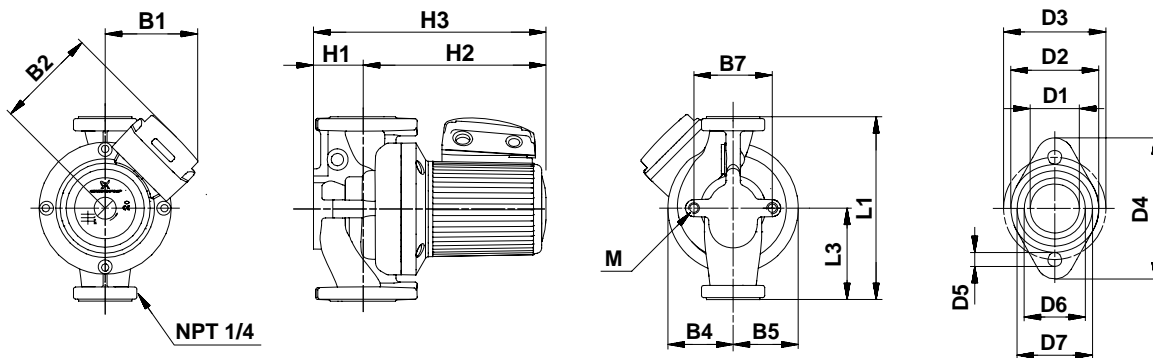

Dimensions

	L1	L3	B1	B2	B4	B5	B7	H1	H2	H3	D1	D2	D3	D4	D5	D6	D7	M
[Inches]	13 1/2	6 3/4	5 3/4	6 5/8	4	4	3 3/16	2 11/16	11 1/16	13 3/4	1 11/16	2 7/8	3 7/16	5	1/2	2 1/16	2 9/16	
[mm]	342.9	171.5	145	169	100	100	80	68	281	349	41.8	73	87	127	12	52	64.6	M12

Performance curves

UPS 40-240/2
3 phase 208-230 V, 460 V, 575 V ★, 60 Hz

Performance curves

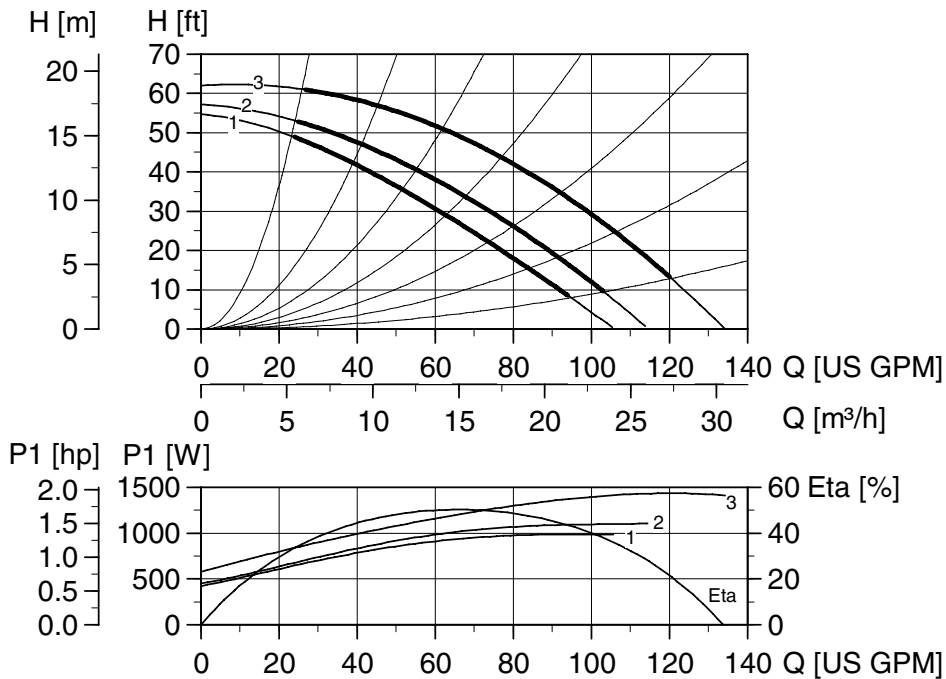

Note: ETA is calculated as wire-to-water efficiency.

Weights and volume

	Cast Iron				Bronze			
	lbs.	ft ³	Kg	m ³	lbs.	ft ³	Kg	m ³
Net weight	47.2		21.4		51.6		23.4	
Gross weight	59.5		27.0		63.9		29	
Shipping volume		2.90		0.082		2.90		0.082

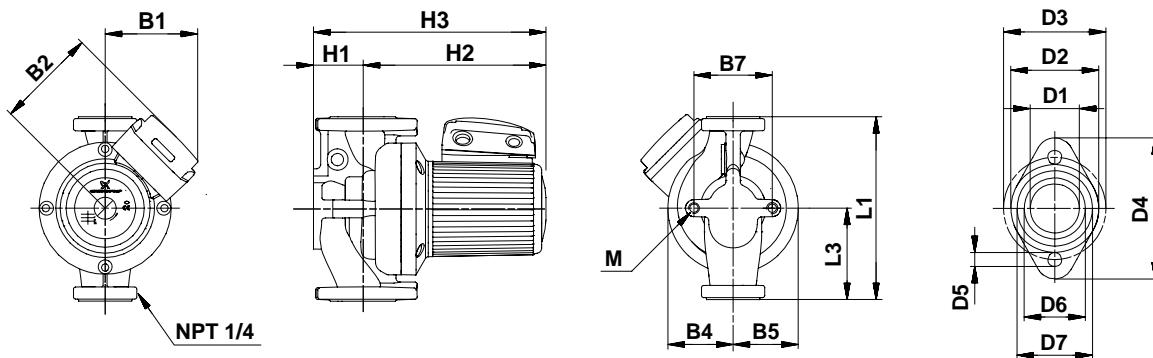

Dimensions

	L1	L3	B1	B2	B4	B5	B7	H1	H2	H3	D1	D2	D3	D4	D5	D6	D7	M
[Inches]	13 1/2	6 3/4	5 3/4	6 5/8	4	4	3 3/16	2 11/16	11 1/16	13 3/4	1 11/16	2 7/8	3 7/16	5	1/2	2 1/16	2 9/16	
[mm]	342.9	171.5	145	169	100	100	80	68	281	349	41.8	73	87	127	12	52	64.6	M12

★Canada only

Performance curves

UPS 50-40/4
1 phase 115 V, 230 V, 60 Hz

Performance curves

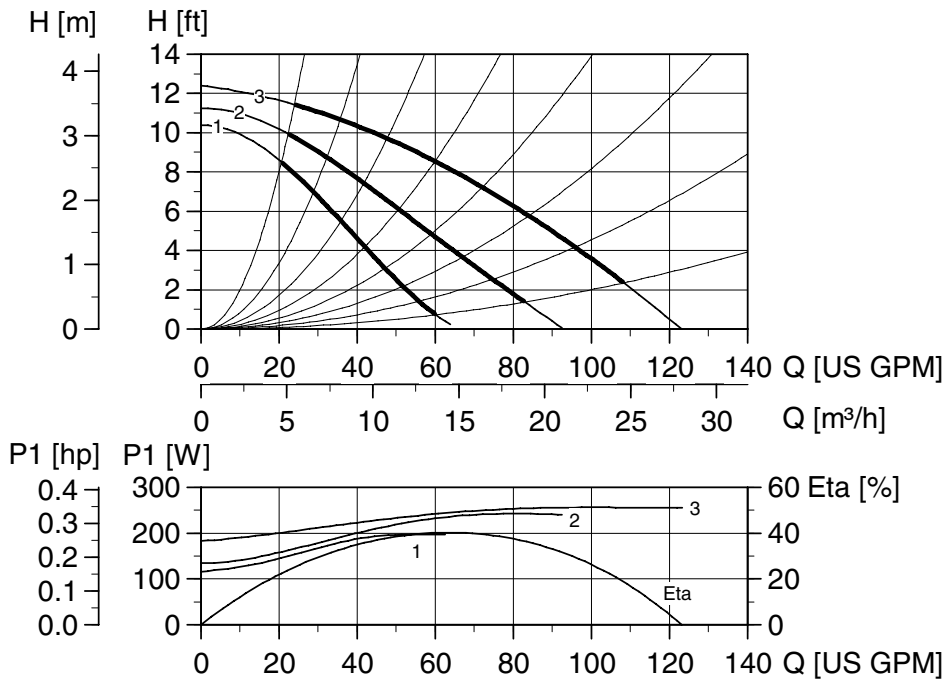

Note: ETA is calculated as wire-to-water efficiency.

Weights and volume

	Cast Iron				Bronze			
	lbs.	ft ³	Kg	m ³	lbs.	ft ³	Kg	m ³
Net weight	43.7		19.8		53.6		24.3	
Gross weight	51.8		23.5		61.7		28	
Shipping volume		1.70		0.048		1.70		0.048

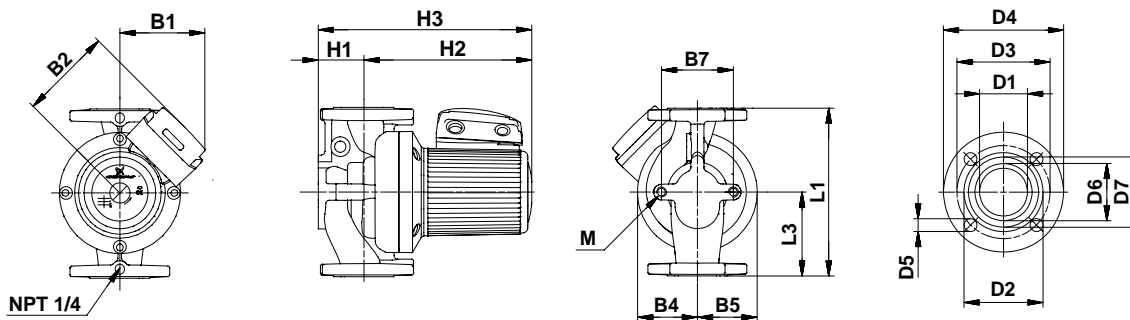

Dimensions

	L1	L3	B1	B2	B4	B5	B7	H1	H2	H3	D1	D2	D3	D4	D5	D6	D7	M
[Inches]	14	7	5 5/16	5 9/16	3 9/16	3	4 3/4	3 1/4	10 1/8	12 13/16	2 1/8	3 7/16	4 1/16	5 1/4	9/16	2 1/2	3 1/16	
[mm]	355.6	177.8	135	141	90	75	160	82	257	325	53	87.5	103	133	14	63	77.8	M12

Performance curves

UPS 50-40/4
3 phase 208-230 V, 460 V, 575 V ★, 60 Hz

Performance curves

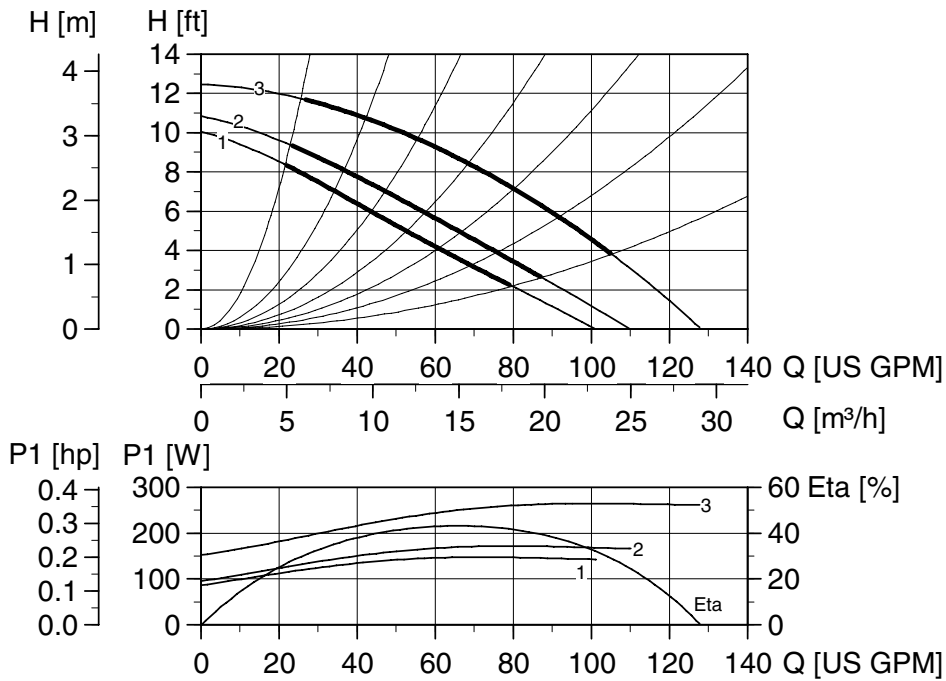

Note: ETA is calculated as wire-to-water efficiency.

Weights and volume

	Cast Iron				Bronze			
	lbs.	ft ³	Kg	m ³	lbs.	ft ³	Kg	m ³
Net weight	43.7		19.8		53.6		24.3	
Gross weight	51.8		23.5		61.7		28	
Shipping volume		1.70		0.048		1.70		0.048

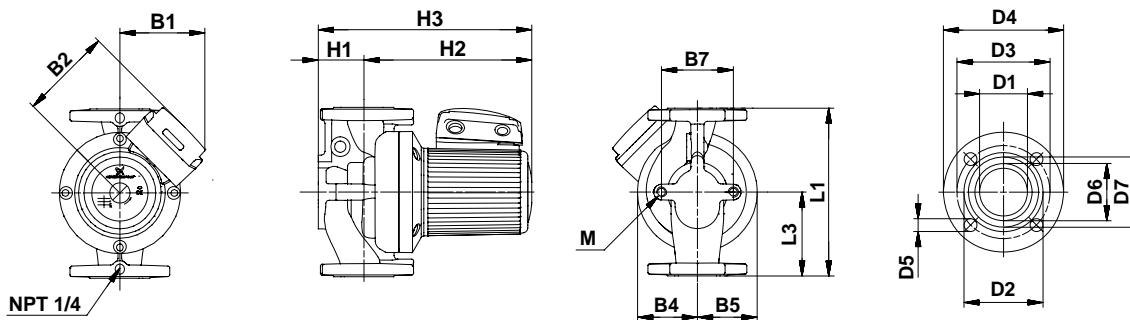

Dimensions

	L1	L3	B1	B2	B4	B5	B7	H1	H2	H3	D1	D2	D3	D4	D5	D6	D7	M
[Inches]	14	7	5 5/16	5 9/16	3 9/16	3	4 3/4	3 1/4	10 1/8	12 13/16	2 1/8	3 7/16	4 1/16	5 1/4	9/16	2 1/2	3 1/16	
[mm]	355.6	177.8	135	141	90	75	160	82	257	325	53	87.5	103	133	14	63	77.8	M12

★Canada only

Performance curves

UPS 50-80/4
1 phase 115 V, 230 V, 60 Hz

Performance curves

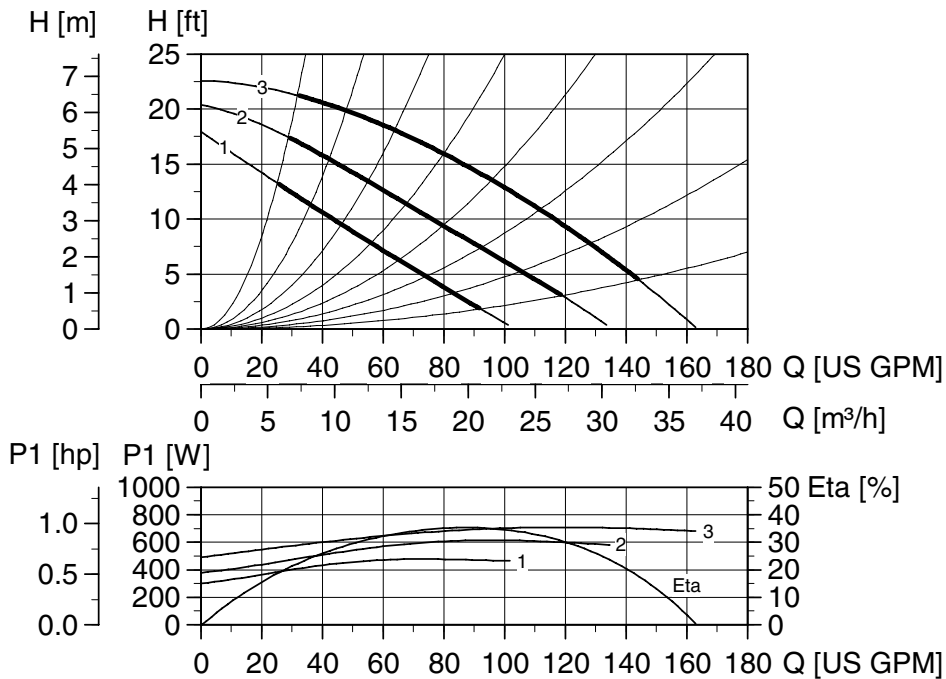

Note: ETA is calculated as wire-to-water efficiency.

Weights and volume

	Cast Iron				Bronze			
	lbs.	ft ³	Kg	m ³	lbs.	ft ³	Kg	m ³
Net weight	60.2		27.3		66.8		30.3	
Gross weight	72.5		32.9		79.1		35.9	
Shipping volume		2.90		0.082		2.90		0.082

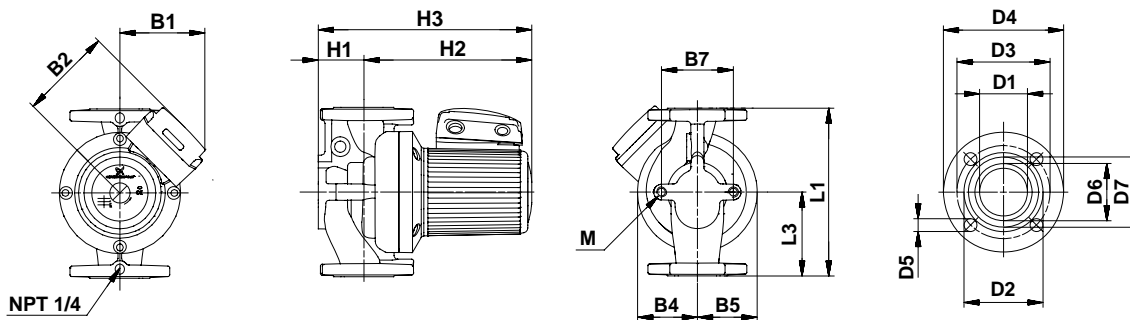

Dimensions

	L1	L3	B1	B2	B4	B5	B7	H1	H2	H3	D1	D2	D3	D4	D5	D6	D7	M
[Inches]	11 1/2	7	5 3/4	6 11/16	4 3/8	3 15/16	4 3/4	3 1/4	10 7/8	14 1/8	2 1/8	3 7/16	4 1/16	5 1/4	9/16	2 1/2	3 1/16	
[mm]	292	177.8	145	169	110	100	120	82	277	359	53	87.5	103	133	14	63	77.8	M12

Performance curves

UPS 50-80/4
3 phase 208-230 V, 460 V, 575 V ★, 60 Hz

Performance curves

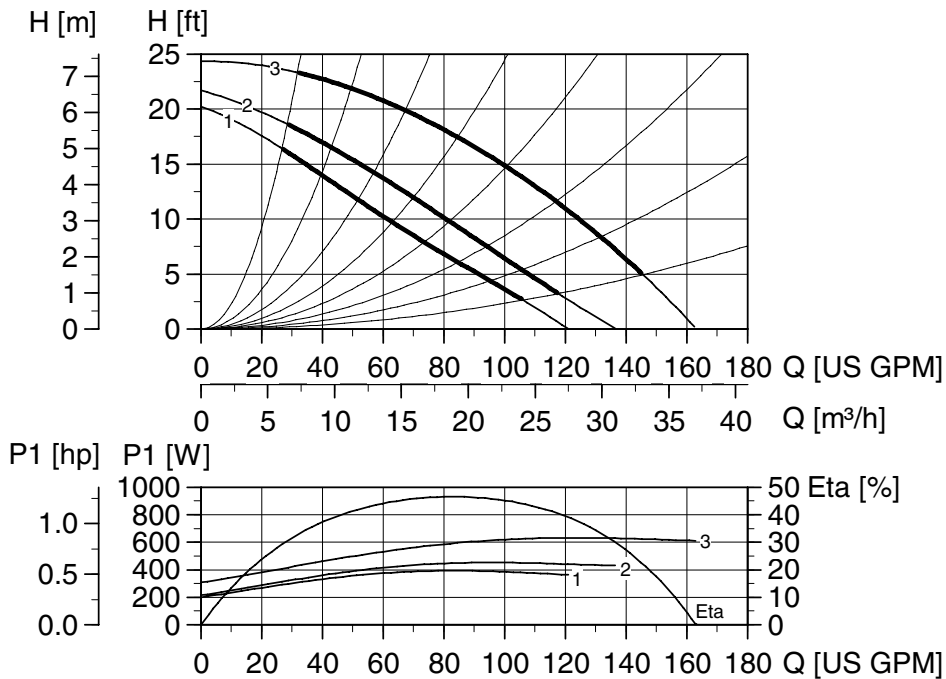

Note: ETA is calculated as wire-to-water efficiency.

Weights and volume

	Cast Iron				Bronze			
	lbs.	ft ³	Kg	m ³	lbs.	ft ³	Kg	m ³
Net weight	59.5		27		66.8		30.3	
Gross weight	71.9		32.6		79.1		35.9	
Shipping volume		2.90		0.082		2.90		0.082

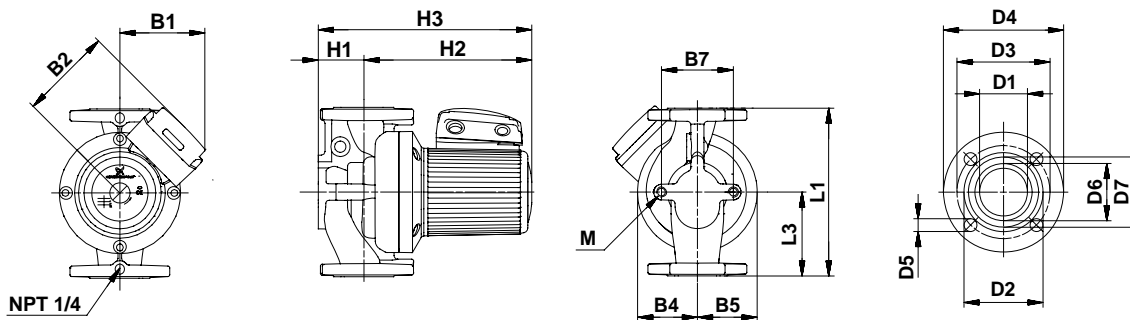

Dimensions

	L1	L3	B1	B2	B4	B5	B7	H1	H2	H3	D1	D2	D3	D4	D5	D6	D7	M
[Inches]	11 1/2	7	5 3/4	6 11/16	4 3/8	3 15/16	4 3/4	3 1/4	10 7/8	14 1/8	2 1/8	3 7/16	4 1/16	5 1/4	9/16	2 1/2	3 1/16	
[mm]	292	177.8	145	169	110	100	120	82	277	359	53	87.5	103	133	14	63	77.8	M12

★Canada only

Performance curves

UPS 50-80/2
1 phase 115 V, 230 V, 60 Hz

Performance curves

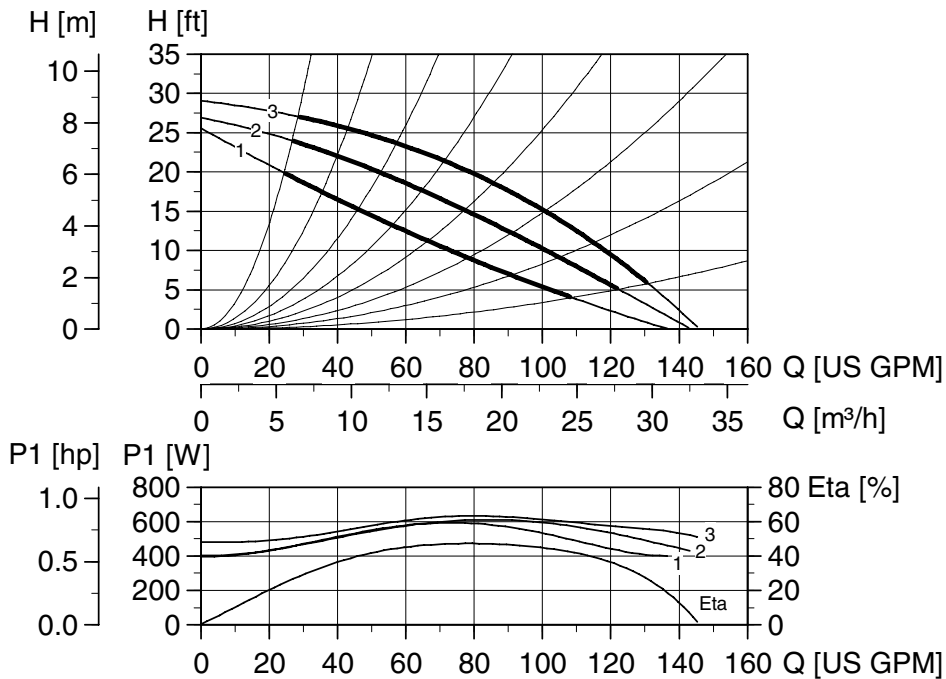

Note: ETA is calculated as wire-to-water efficiency.

Weights and volume

	Cast Iron				Bronze			
	lbs.	ft ³	Kg	m ³	lbs.	ft ³	Kg	m ³
Net weight	46.7		21.2		52.2		23.7	
Gross weight	54.2		24.6		59.7		27.1	
Shipping volume		1.70		0.048		1.70		0.048

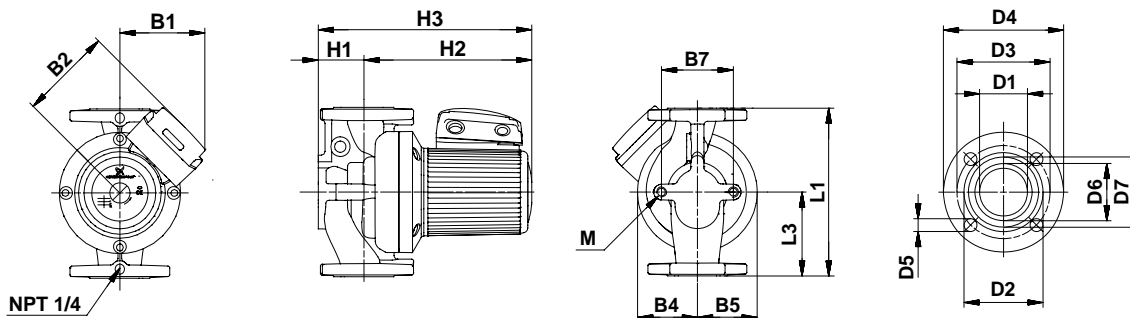

Dimensions

	L1	L3	B1	B2	B4	B5	B7	H1	H2	H3	D1	D2	D3	D4	D5	D6	D7	M
[Inches]	11 1/2	7	5 5/16	5 9/16	3 3/4	3	4 3/4	3	9 7/8	12 13/16	2 1/8	3 7/16	4 1/16	5 1/4	9/16	2 1/2	3 1/16	
[mm]	292	177.8	135	141	95	75	120	75	251	326	53	87.5	103	133	14	63	77.8	M12

Performance curves

UPS 50-80/2
3 phase 208-230 V, 460 V, 575 V ★, 60 Hz

Performance curves

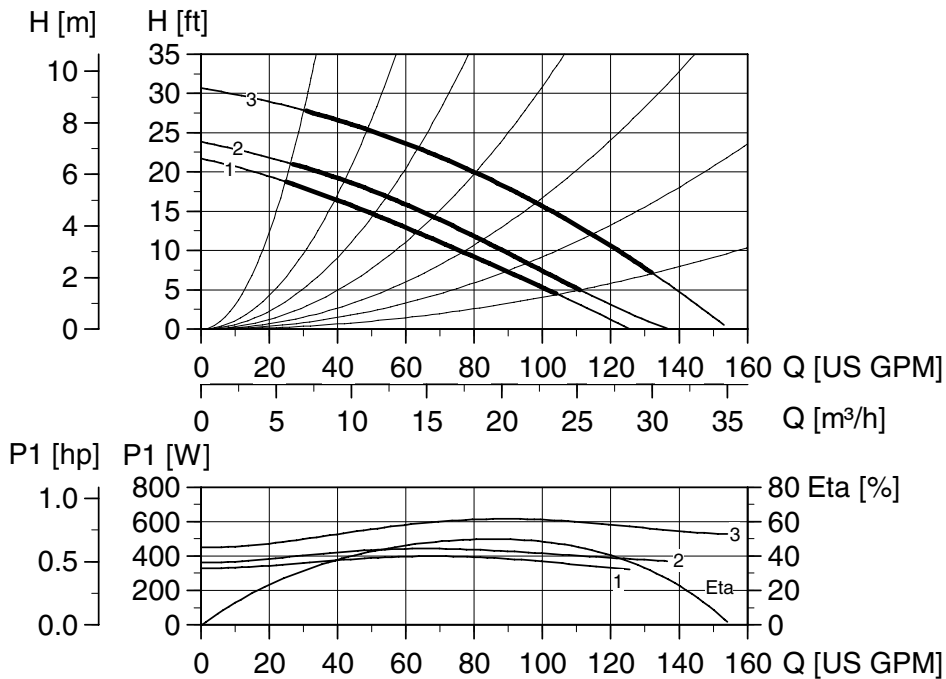

Note: ETA is calculated as wire-to-water efficiency.

Weights and volume

	Cast Iron				Bronze			
	lbs.	ft ³	Kg	m ³	lbs.	ft ³	Kg	m ³
Net weight	45.9		20.8		52.2		23.7	
Gross weight	53.4		24.2		59.7		27.1	
Shipping volume		1.70		0.048		1.70		0.048

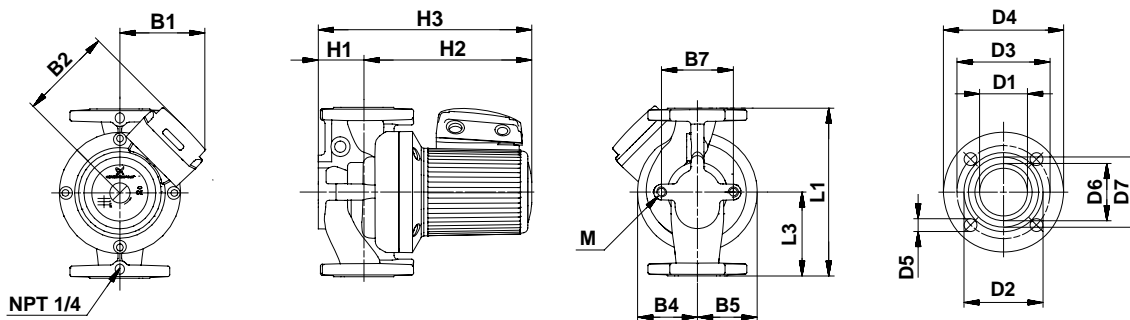

Dimensions

	L1	L3	B1	B2	B4	B5	B7	H1	H2	H3	D1	D2	D3	D4	D5	D6	D7	M
[Inches]	11 1/2	7	5 5/16	5 9/16	3 3/4	3	4 3/4	3	9 7/8	12 13/16	2 1/8	3 7/16	4 1/16	5 1/4	9/16	2 1/2	3 1/16	
[mm]	292	177.8	135	141	95	75	120	75	251	326	53	87.5	103	133	14	63	77.8	M12

★Canada only

Performance curves

UPS 50-160/2
1 phase 230 V, 60 Hz

Performance curves

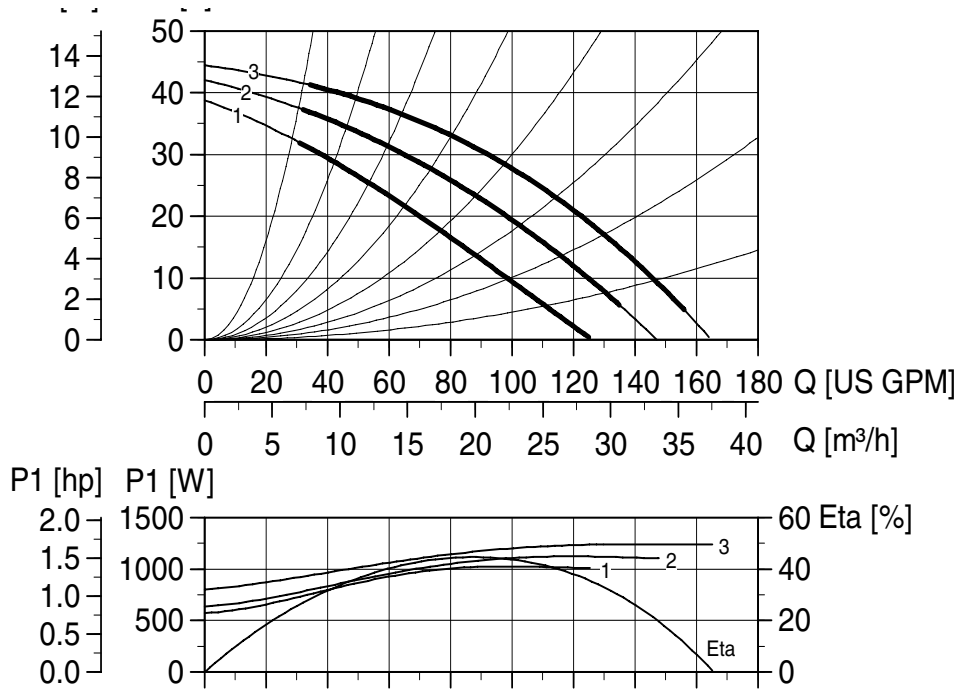

Note: ETA is calculated as wire-to-water efficiency.

Weights and volume

	Cast Iron				Bronze			
	lbs.	ft ³	Kg	m ³	lbs.	ft ³	Kg	m ³
Net weight	53.6		24.3		68.3		31	
Gross weight	65.9		29.9		80.7		36.6	
Shipping volume		2.90		0.082		2.90		0.082

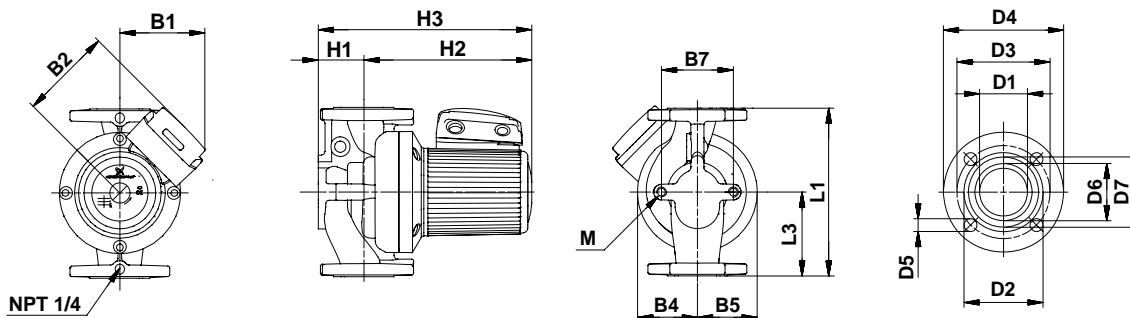

Dimensions

	L1	L3	B1	B2	B4	B5	B7	H1	H2	H3	D1	D2	D3	D4	D5	D6	D7	M
[Inches]	14	7	5 3/4	6 11/16	3 15/16	3 15/16	4 3/4	3	10 13/16	13 3/4	2 1/8	3 7/16	4 1/16	5 1/4	9/16	2 1/2	3 1/16	
[mm]	355	177.8	145	169	100	100	120	75	274	349	53	87.5	103	133	14	63	77.8	M12

Performance curves

UPS 50-160/2
3 phase 208-230 V, 460 V, 575 V ★, 60 Hz

Performance curves

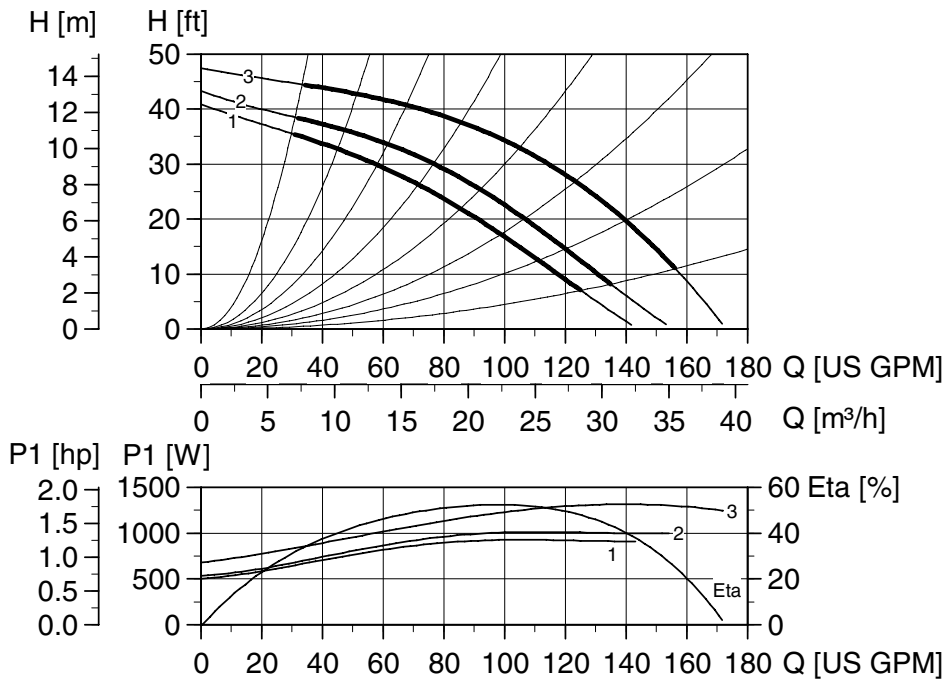

Note: ETA is calculated as wire-to-water efficiency.

Weights and volume

	Cast Iron				Bronze			
	lbs.	ft ³	Kg	m ³	lbs.	ft ³	Kg	m ³
Net weight	53.6		24.3		68.3		31	
Gross weight	65.9		29.9		80.7		36.6	
Shipping volume		2.90		0.082		2.90		0.082

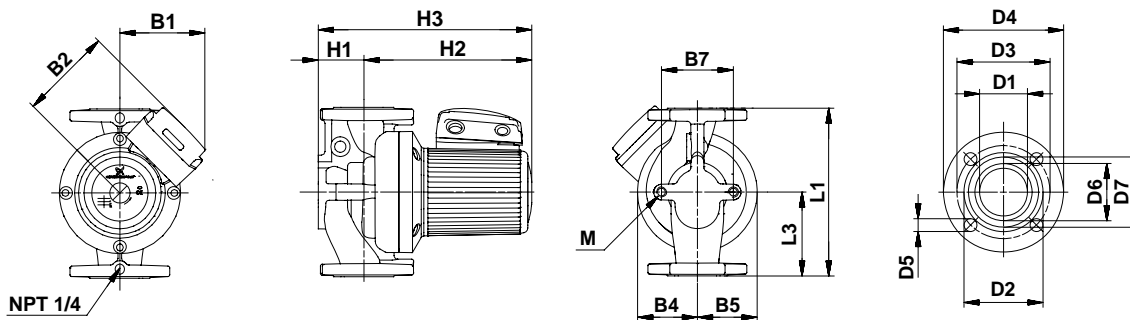

Dimensions

	L1	L3	B1	B2	B4	B5	B7	H1	H2	H3	D1	D2	D3	D4	D5	D6	D7	M
[Inches]	14	7	5 3/4	6 11/16	3 15/16	3 15/16	4 3/4	3	10 13/16	13 3/4	2 1/8	3 7/16	4 1/16	5 1/4	9/16	2 1/2	3 1/16	
[mm]	355	177.8	145	169	100	100	120	75	274	349	53	87.5	103	133	14	63	77.8	M12

★Canada only

Performance curves

UPS 50-240/2
3 phase 208-230 V, 460 V, 575 V ★, 60 Hz

Performance curves

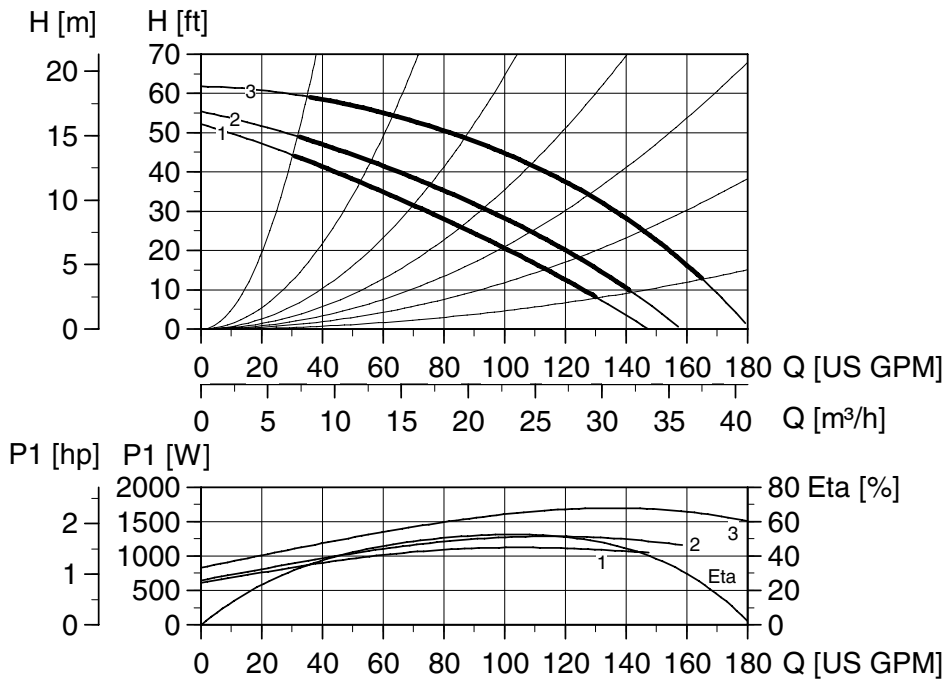

Note: ETA is calculated as wire-to-water efficiency.

Weights and volume

	Cast Iron				Bronze			
	lbs.	ft ³	Kg	m ³	lbs.	ft ³	Kg	m ³
Net weight	60.6		27.5		67.2		30.5	
Gross weight	73.0		33.1		79.6		36.1	
Shipping volume		2.90		0.082		2.90		0.082

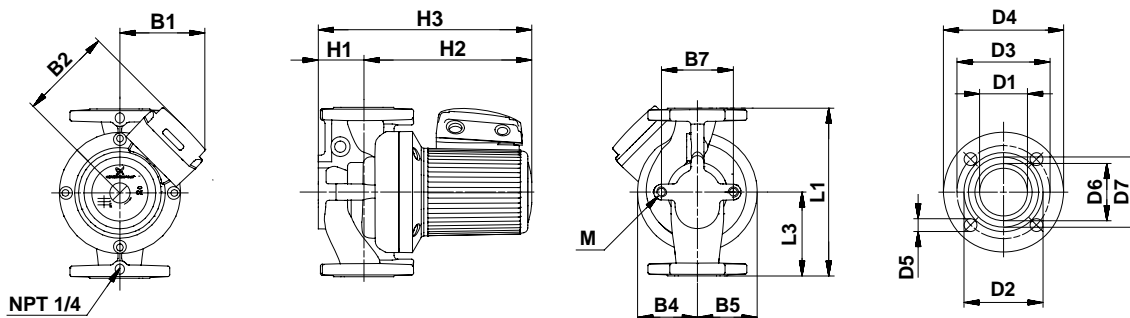

Dimensions

	L1	L3	B1	B2	B4	B5	B7	H1	H2	H3	D1	D2	D3	D4	D5	D6	D7	M
[Inches]	14	7	5 3/4	6 11/16	3 15/16	3 15/16	4 3/4	3	10 3/4	13 11/16	2 1/8	3 7/16	4 1/16	5 1/4	9/16	2 1/2	3 1/16	
[mm]	355	177.8	145	169	100	100	120	75	273	348	53	87.5	103	133	14	63	77.8	M12

★Canada only

Performance curves

UPS 53-55/57
1 phase 115 V, 230 V, 60 Hz

Performance curves

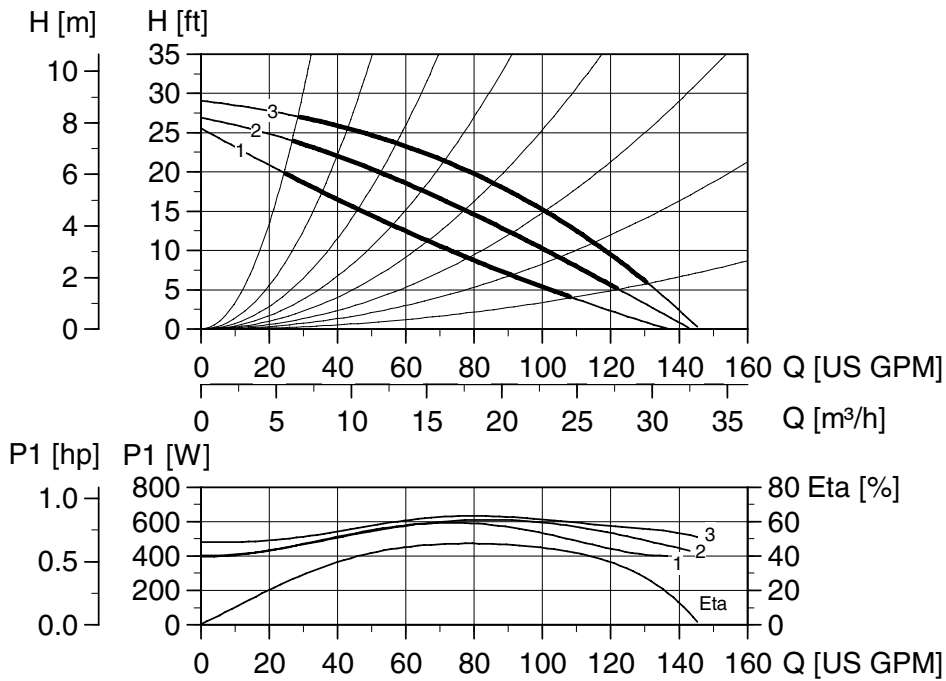

Note: ETA is calculated as wire-to-water efficiency.

Weights and volume

	Cast Iron				Bronze			
	lbs.	ft ³	Kg	m ³	lbs.	ft ³	Kg	m ³
Net weight	46.7		21.2		52.2		23.7	
Gross weight	54.2		24.6		59.7		27.1	
Shipping volume		2.1		0.06		2.1		0.06

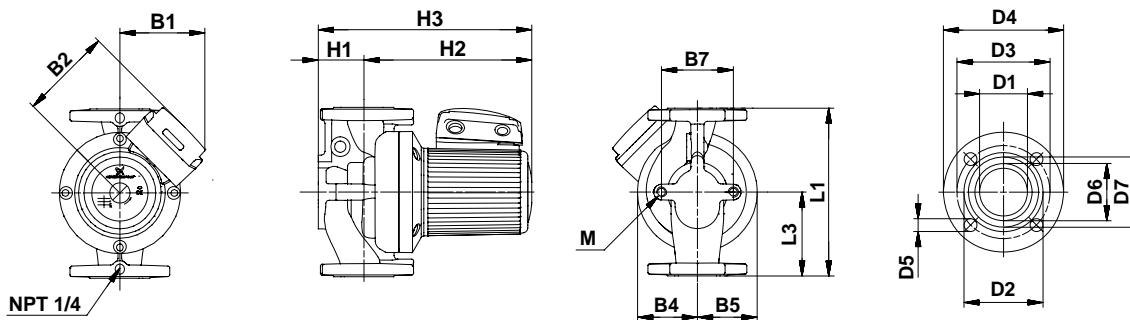

Dimensions

	L1	L3	B1	B2	B4	B5	B7	H1	H2	H3	D1	D2	D3	D4	D5	D6	D7	M
[Inches]	11 7/8	5 15/16	5 5/16	5 9/16	3 3/4	2 15/16	4 3/4	2 15/16	9 14/16	12 13/16	2 1/16	4 3/16	5	6	5/8	3 1/2	4	
[mm]	302	151	135	141	95	75	120	75	251	326	53	106	127	152	16	89	101	M12

Performance curves

UPS 53-55/57
3 phase 208-230 V, 460 V, 575 V ★, 60 Hz

Performance curves

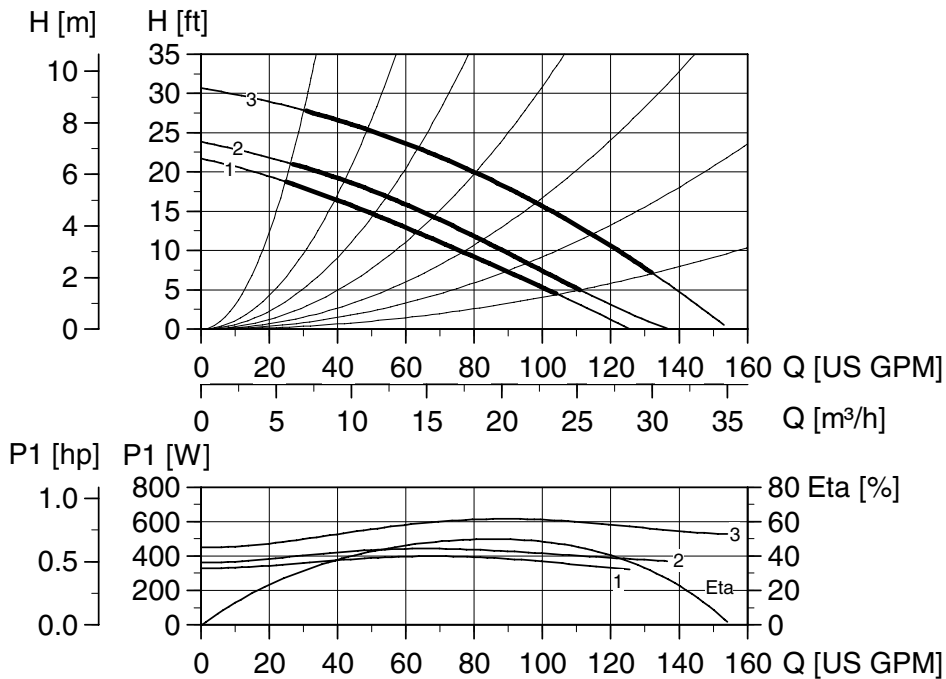

Note: ETA is calculated as wire-to-water efficiency.

Weights and volume

	Cast Iron				Bronze			
	lbs.	ft ³	Kg	m ³	lbs.	ft ³	Kg	m ³
Net weight	46.7		21.2		52.2		23.7	
Gross weight	54.2		24.6		59.7		27.1	
Shipping volume		2.1		0.06		2.1		0.06

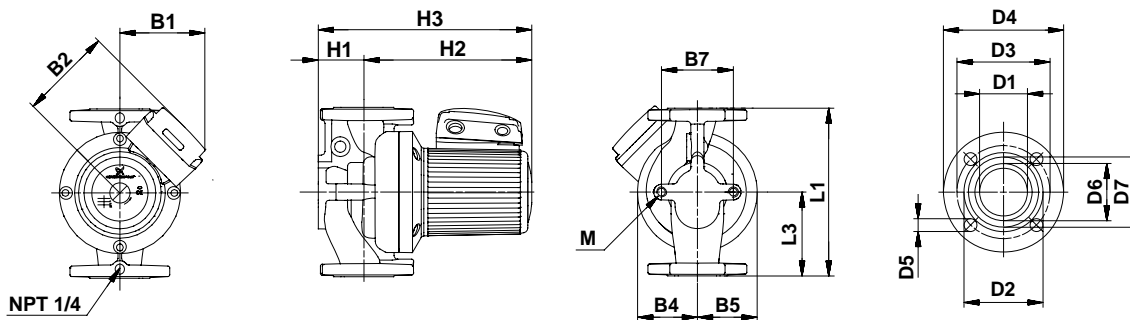

Dimensions

	L1	L3	B1	B2	B4	B5	B7	H1	H2	H3	D1	D2	D3	D4	D5	D6	D7	M
[Inches]	11 7/8	5 15/16	5 5/16	5 9/16	3 3/4	2 15/16	4 3/4	2 15/16	9 14/16	12 13/16	2 1/16	4 3/16	5	6	5/8	3 1/2	4	
[mm]	302	151	135	141	95	75	120	75	251	326	53	106	127	152	16	89	101	M12

★Canada only

Performance curves

UPS 75-69
1 phase 115 V, 230 V, 60 Hz

Performance curves

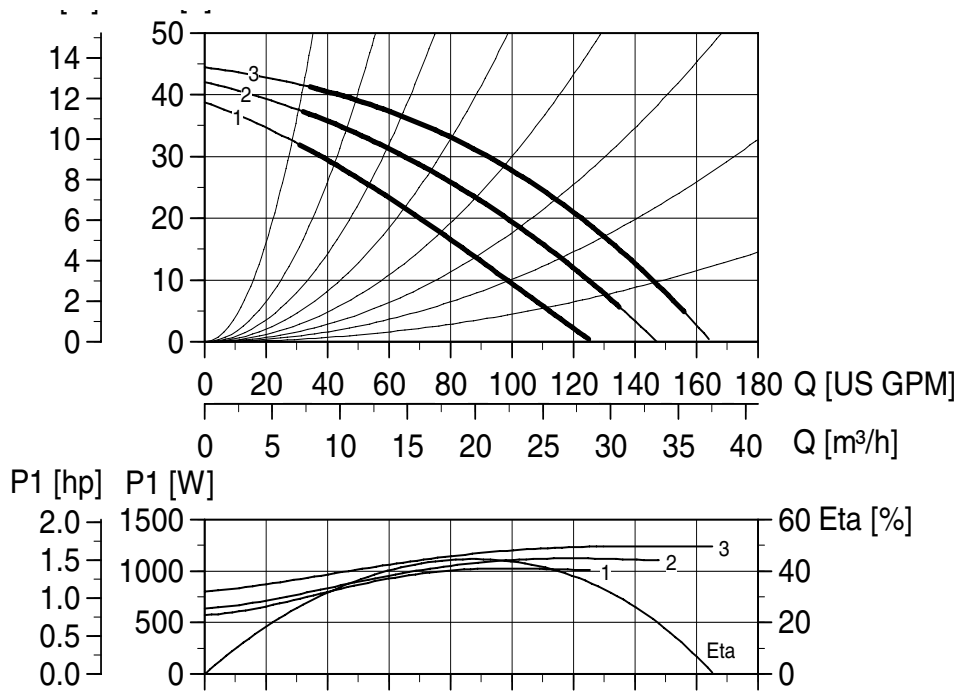

Note: ETA is calculated as wire-to-water efficiency.

Weights and volume

	Cast Iron				Bronze			
	lbs.	ft ³	Kg	m ³	lbs.	ft ³	Kg	m ³
Net weight	53.6		24.3		68.3		31	
Gross weight	65.7		29.8		80.5		36.5	
Shipping volume		3.5		0.098		3.5		0.098

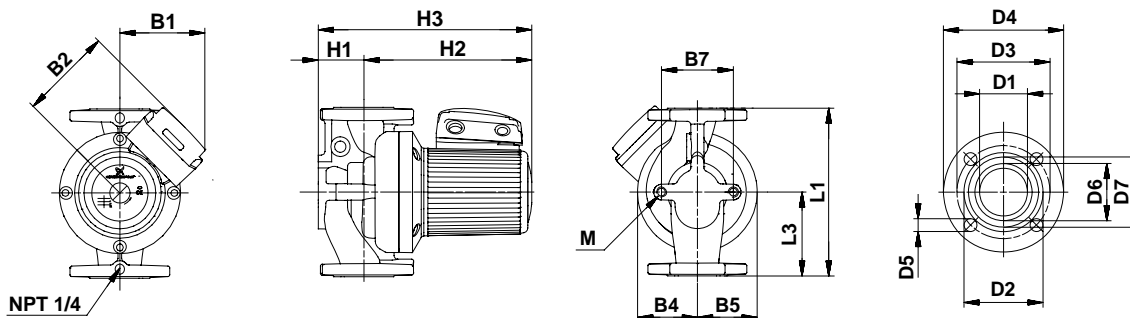

Dimensions

	L1	L3	B1	B2	B4	B5	B7	H1	H2	H3	D1	D2	D3	D4	D5	D6	D7	M
[Inches]	14 1/4	7 1/8	5 11/16	6 5/8	3 15/16	3 15/16	4 1/2	2 15/16	10 13/16	13 1/2	2 15/16	4 5/16	6	7 1/2	12/16	3 1/2	4	
[mm]	362	181	145	169	100	100	120	75	274	349	75	110	152	190	19	89	101	M12

TM00 9413 2297

TM02 0730 5100

Performance curves

UPS 75-69
3 phase 208-230 V, 460 V, 575 V ★, 60 Hz

Performance curves

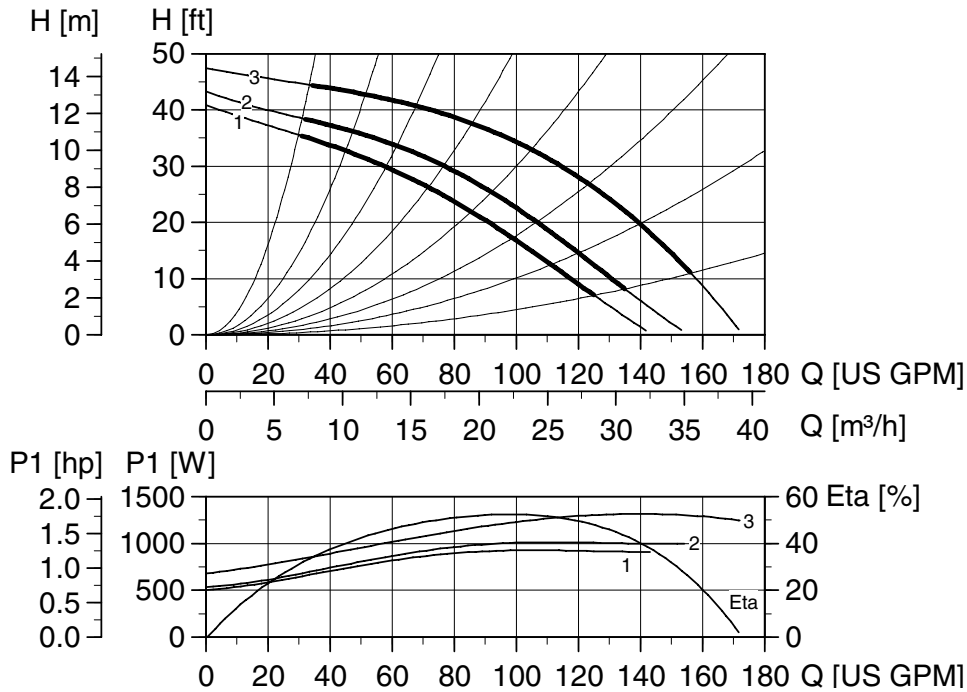

Note: ETA is calculated as wire-to-water efficiency.

Weights and volume

	Cast Iron				Bronze			
	lbs.	ft ³	Kg	m ³	lbs.	ft ³	Kg	m ³
Net weight	53.6		24.3		68.3		31	
Gross weight	65.7		29.8		80.5		36.5	
Shipping volume		3.5		0.098		3.5		0.098

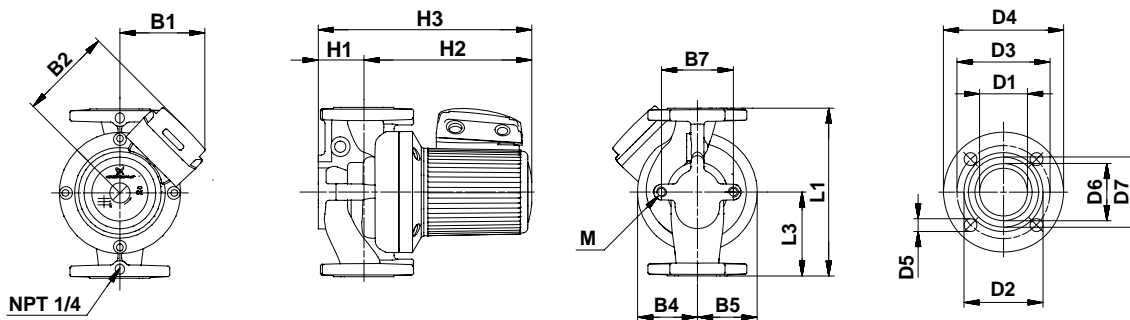

Dimensions

	L1	L3	B1	B2	B4	B5	B7	H1	H2	H3	D1	D2	D3	D4	D5	D6	D7	M
[Inches]	14 1/4	7 1/8	5 11/16	6 5/8	3 15/16	3 15/16	4 1/2	2 15/16	10 13/16	13 1/2	2 15/16	4 5/16	6	7 1/2	12/16	3 1/2	4	
[mm]	362	181	145	169	100	100	120	75	274	349	75	110	152	190	19	89	101	M12

★Canada only

Performance curves

UPS 80-40/4
3 phase 208-230 V, 460 V, 575 V ★, 60 Hz

Performance curves

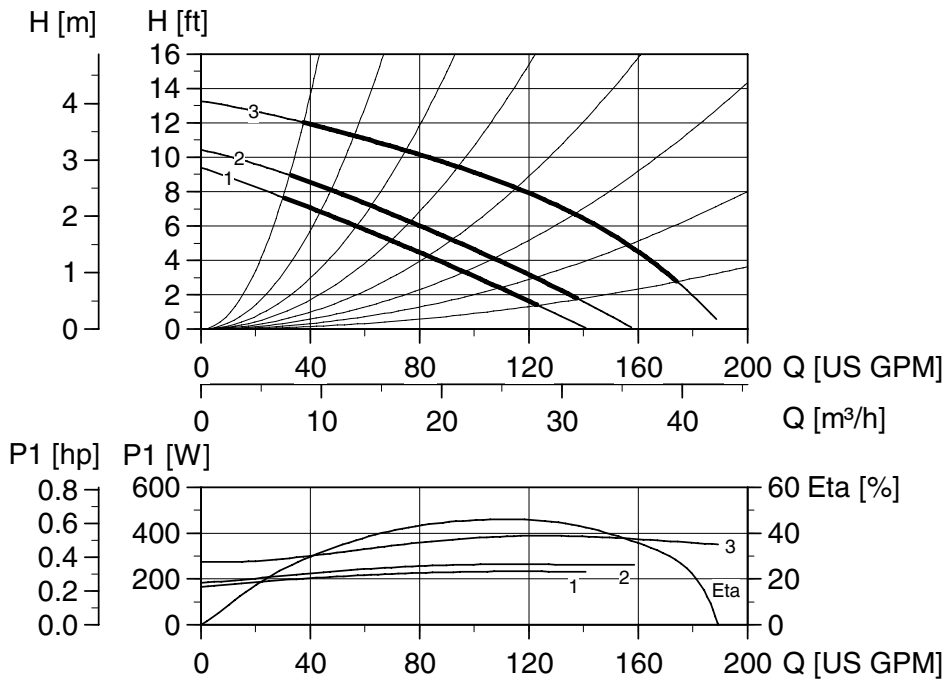

Note: ETA is calculated as wire-to-water efficiency.

Weights and volume

	Cast Iron				Bronze			
	lbs.	ft ³	Kg	m ³	lbs.	ft ³	Kg	m ³
Net weight	78.7		35.7		91.9		41.7	
Gross weight	91.1		41.3		104.3		47.3	
Shipping volume		2.90		0.082		2.90		0.082

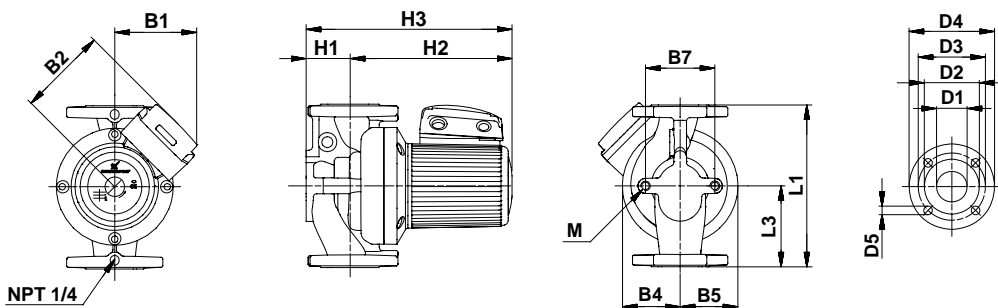

Dimensions

	L1	L3	B1	B2	B4	B5	B7	H1	H2	H3	D1	D2	D3	D4	D5	M
[Inches]	19	9 1/2	5 3/4	6 11/16	4 15/16	3 15/16	6 5/16	3 13/16	9 7/16	13 1/8	3 3/16	5	6	7 9/16	3/4	
[mm]	482.6	241.3	145	169	125	100	160	97	240	337	81	127	152	191	19	M16

★Canada only

Performance curves

UPS 80-80/4
3 phase 208-230 V, 60 Hz

Performance curves

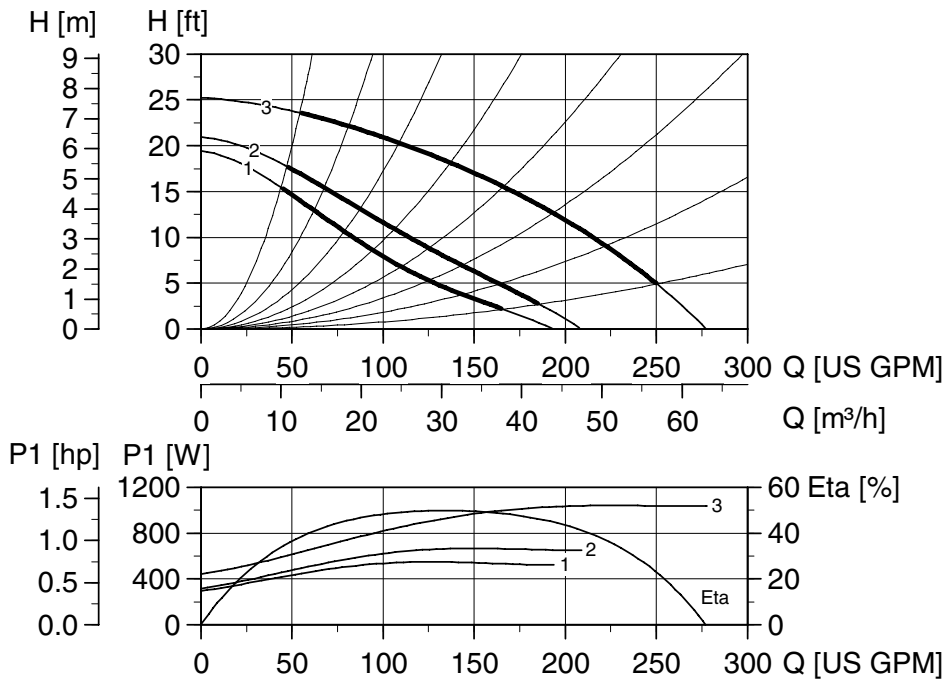

Note: ETA is calculated as wire-to-water efficiency.

Weights and volume

	Cast Iron				Bronze			
	lbs.	ft ³	Kg	m ³	lbs.	ft ³	Kg	m ³
Net weight	89.7		40.7		102.3		46.4	
Gross weight	102.1		46.3		114.6		52	
Shipping volume		2.90		0.082		2.90		0.082

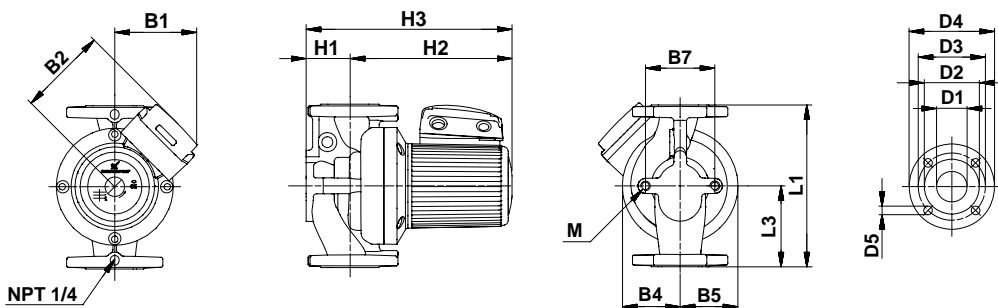

Dimensions

	L1	L3	B1	B2	B4	B5	B7	H1	H2	H3	D1	D2	D3	D4	D5	M
[Inches]	19	9 1/2	5 3/4	6 11/16	4 15/16	3 15/16	6 5/16	3 13/16	11 1/4	15 1/16	3 3/16	5	6	7 9/16	3/4	
[mm]	482.6	241.3	145	169	125	100	160	97	285	387	80.8	127	152	191	19	M16

Performance curves

UPS 80-160/2
3 phase 208-230 V, 460 V, 575 V ★, 60 Hz

Performance curves

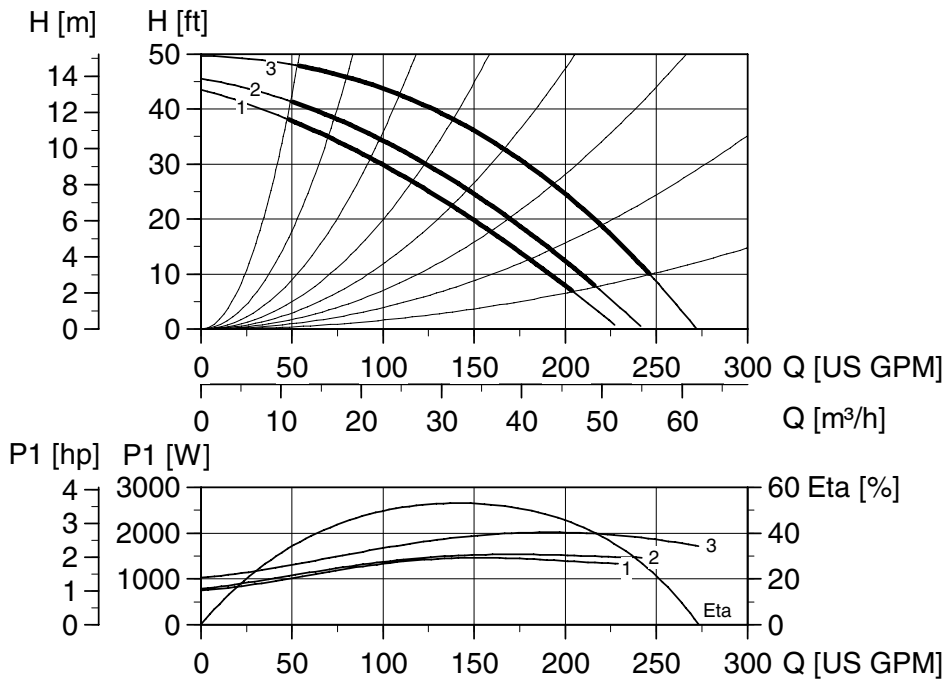

Note: ETA is calculated as wire-to-water efficiency.

Weights and volume

	Cast Iron				Bronze			
	lbs.	ft ³	Kg	m ³	lbs.	ft ³	Kg	m ³
Net weight	85.1		38.6		97.2		44.1	
Gross weight	97.4		44.2		109.6		49.7	
Shipping volume		2.90		0.082		2.90		0.082

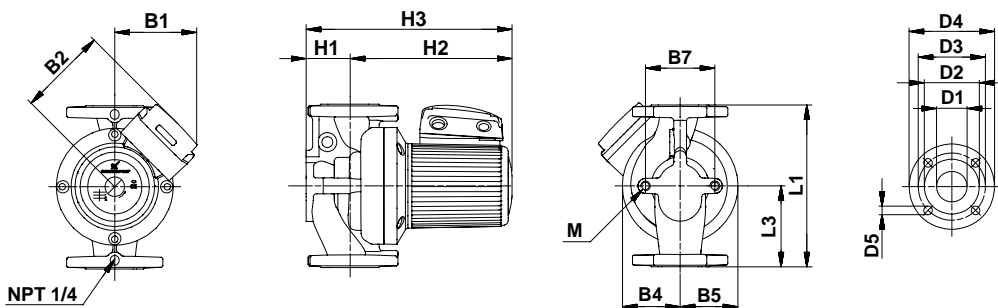

Dimensions

	L1	L3	B1	B2	B4	B5	B7	H1	H2	H3	D1	D2	D3	D4	D5	M
[Inches]	19	9 1/2	5 3/4	6 11/16	3 15/16	3 15/16	6 5/16	3 13/16	11 5/16	15 1/8	3 3/16	5	6	7 9/16	3/4	
[mm]	482.6	241.3	145	169	100	100	160	97	287	384	80.8	127	152	191	19	M16

★Canada only

Performance curves

UPS 100-40/4
3 phase 208-230 V, 460 V, 575 V ★, 60 Hz

Performance curves

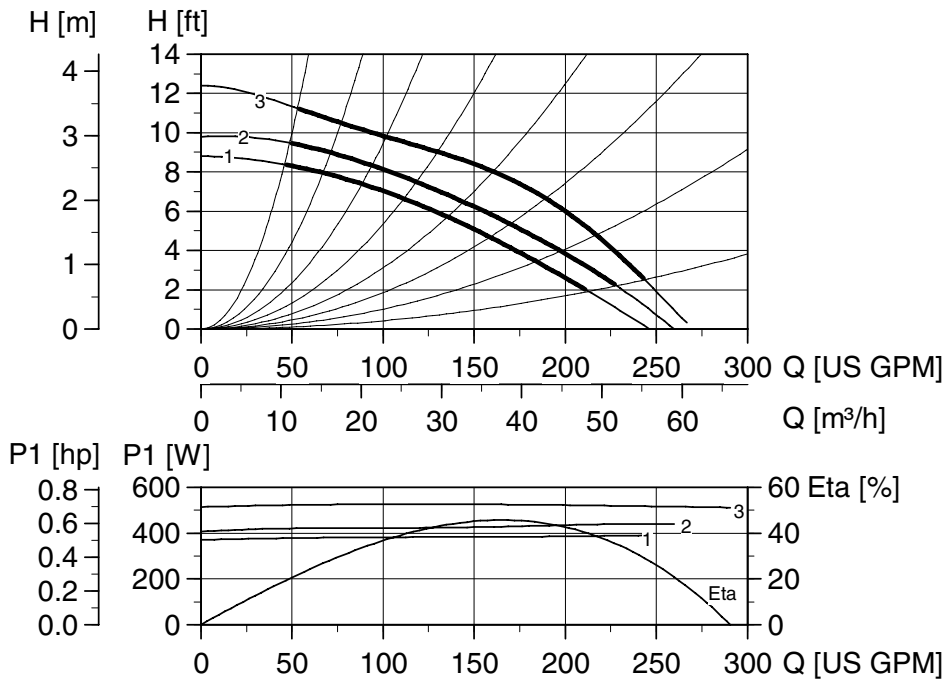

Note: ETA is calculated as wire-to-water efficiency.

Weights and volume

	Cast Iron				Bronze			
	lbs.	ft ³	Kg	m ³	lbs.	ft ³	Kg	m ³
Net weight	126.8		57.5		153.2		69.5	
Gross weight	138.9		63		165.3		75	
Shipping volume		3.53		0.1		3.53		0.1

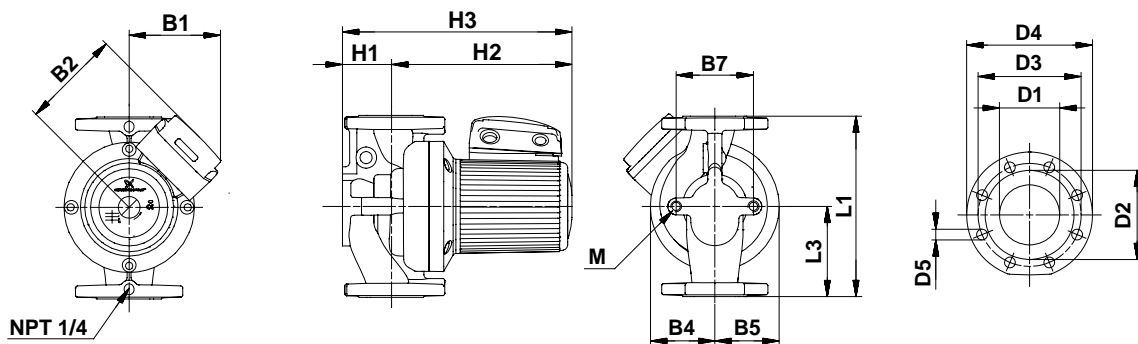

Dimensions

	L1	L3	B1	B2	B4	B5	B7	H1	H2	H3	D1	D2	D3	D4	D5	M
[Inches]	21	10 1/2	5 3/4	6 11/16	5 1/8	3 15/16	6 5/16	4 13/16	12 5/16	16 9/16	4 3/16	6 3/16	7 1/2	9 1/16	3/4	
[mm]	533.4	266.7	145	169	130	100	160	122	313	421	105	157	191	229	19	M16

★Canada only

Performance curves

UP 43-70
1 phase 115 V/230 V, 60 Hz

UP

Performance curves

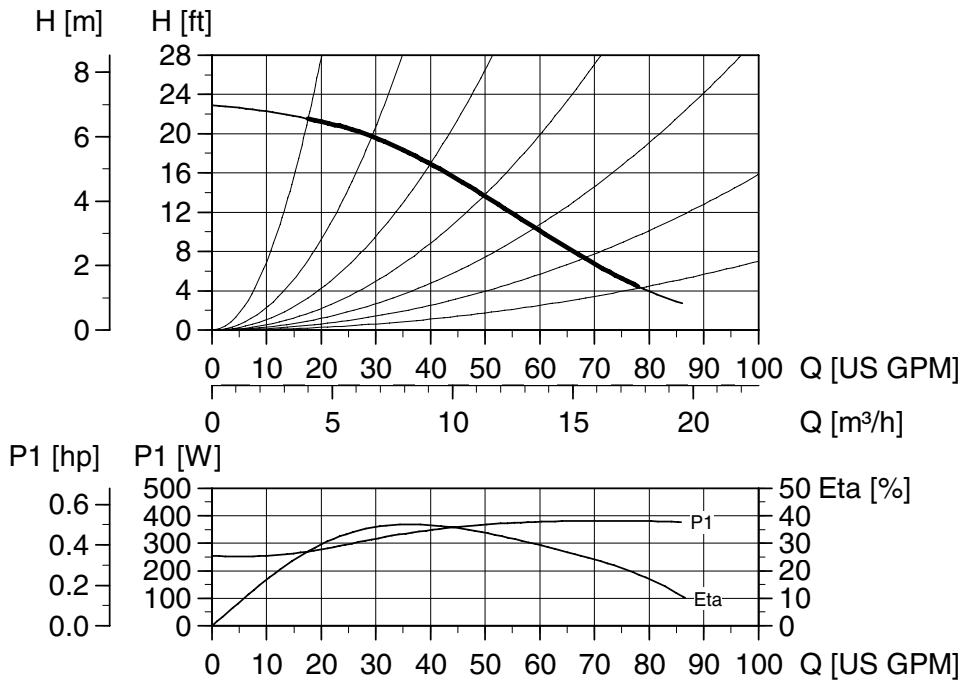

Note: ETA is calculated as wire-to-water efficiency.

Weights and volume

	Cast Iron			
	lbs.	ft ³	Kg	m ³
Net weight	33.1		15.0	
Gross weight	41.2		18.7	
Shipping volume		1.70		0.048

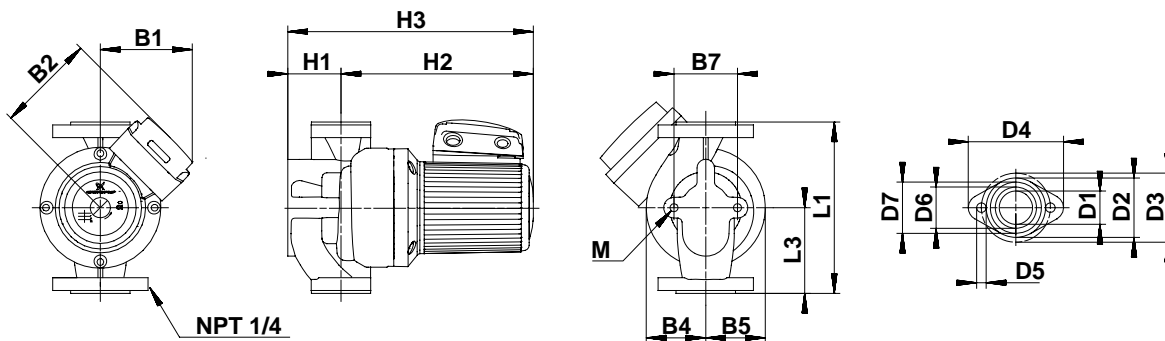

Dimensions

	L1	L3	B1	B2	B4	B5	B7	H1	H2	H3	D1	D2	D3	D4	D5	D6	D7	M
[Inches]	8 1/2	4 1/4	5 1/4	5 9/16	2 15/16	2 15/16	3 1/8	2 5/8	9 5/8	12 3/16	15/8	2 5/16	3 7/16	4 3/4	1/2	2 1/16	2 1/2	
[mm]	216	108	133	141	75	75	80	67	244	310	42	75	87	120	12	52	64.6	12

TM02 0079 4301

TM02 0120 4301

Performance curves

UP 43-110
1 phase 115 V/230 V, 60 Hz

Performance curves

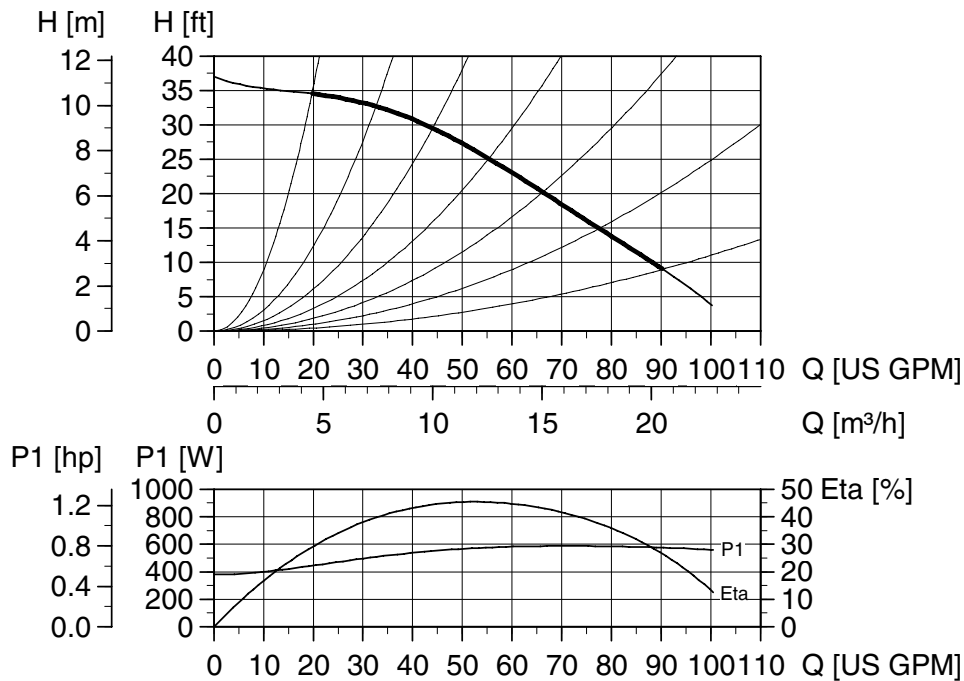

Note: ETA is calculated as wire-to-water efficiency.

Weights and volume

	Cast Iron			
	lbs.	ft ³	Kg	m ³
Net weight	33.1		15.0	
Gross weight	41.2		18.7	
Shipping volume		1.70		0.048

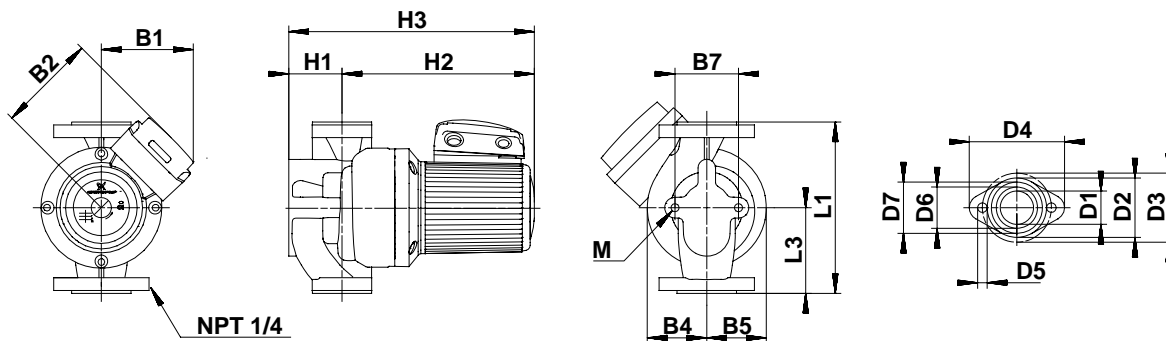

Dimensions

	L1	L3	B1	B2	B4	B5	B7	H1	H2	H3	D1	D2	D3	D4	D5	D6	D7	M
[Inches]	8 1/2	4 1/4	5 1/4	5 9/16	2 15/16	2 15/16	3 1/8	2 5/8	9 5/8	12 3/16	15/8	2 15/16	3 7/16	4 3/4	1/2	2 1/16	2 1/2	
[mm]	216	108	133	141	75	75	80	67	244	310	42	75	87	120	12	52	64.6	12

TM02 0076 4301

TM02 0120 4301

Performance curves

UP 53-45
1 phase 115 V/230 V, 60 Hz

Performance curves

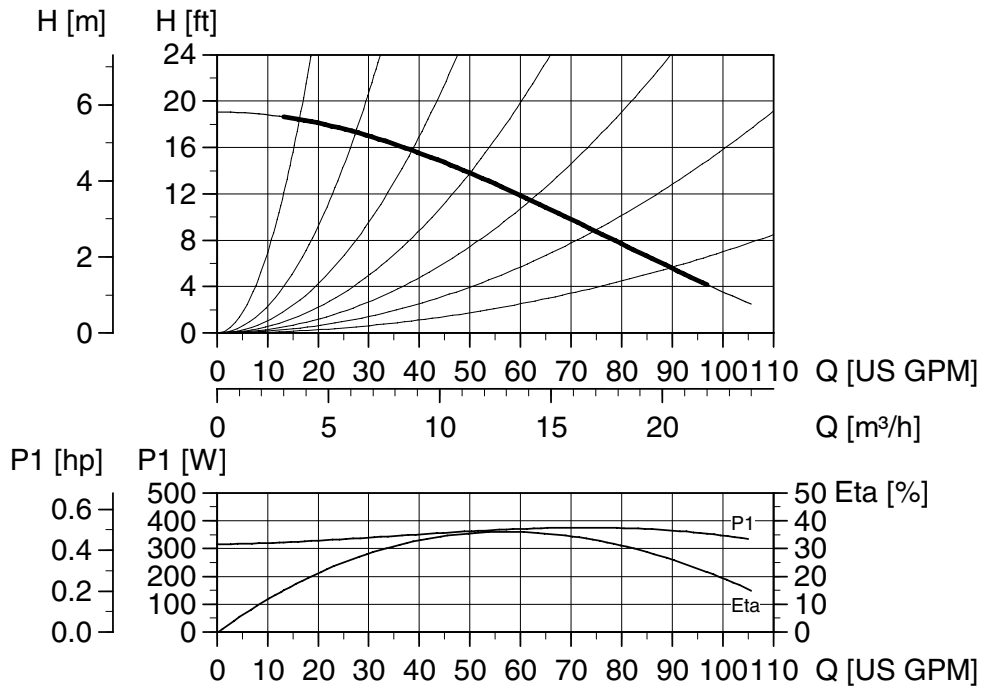

Note: ETA is calculated as wire-to-water efficiency.

Weights and volume

	Cast Iron				Bronze			
	lbs.	ft ³	Kg	m ³	lbs.	ft ³	Kg	m ³
Net weight	44.5		20.2		49.2		22.3	
Gross weight	63.5		23.8		57.1		25.9	
Shipping volume		2.1		0.06		2.1		0.06

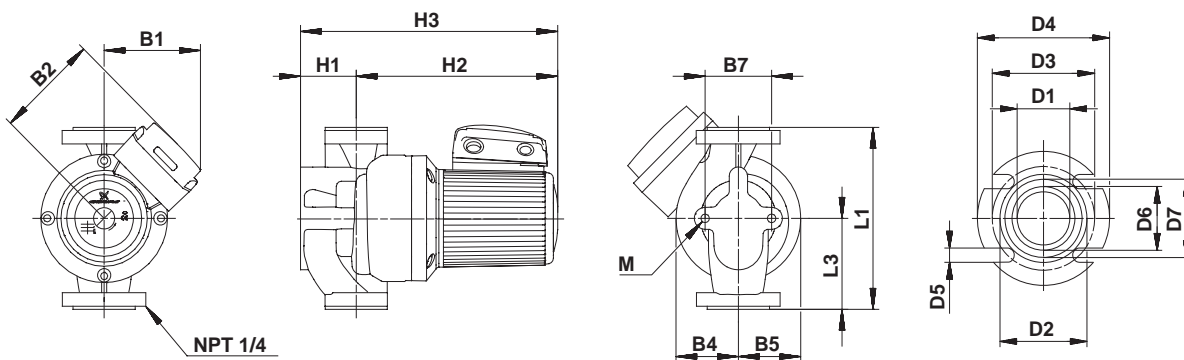

Dimensions

	L1	L3	B1	B2	B4	B5	B7	H1	H2	H3	D1	D2	D3	D4	D5	D6	D7	M
[Inches]	9 7/8	5	5 1/4	5 9/16	3 9/16	2 15/16	4 3/4	2 15/16	9 7/8	12 13/16	2 1/16	4 3/16	5	6	5/8	3 2/4	4	
[mm]	250	127	133	141	91	75	120	75	251	326	53	106	127	152	16	89	101	M12

Performance curves

UP 53-46
1 phase 115 V/230 V, 60 Hz

Performance curves

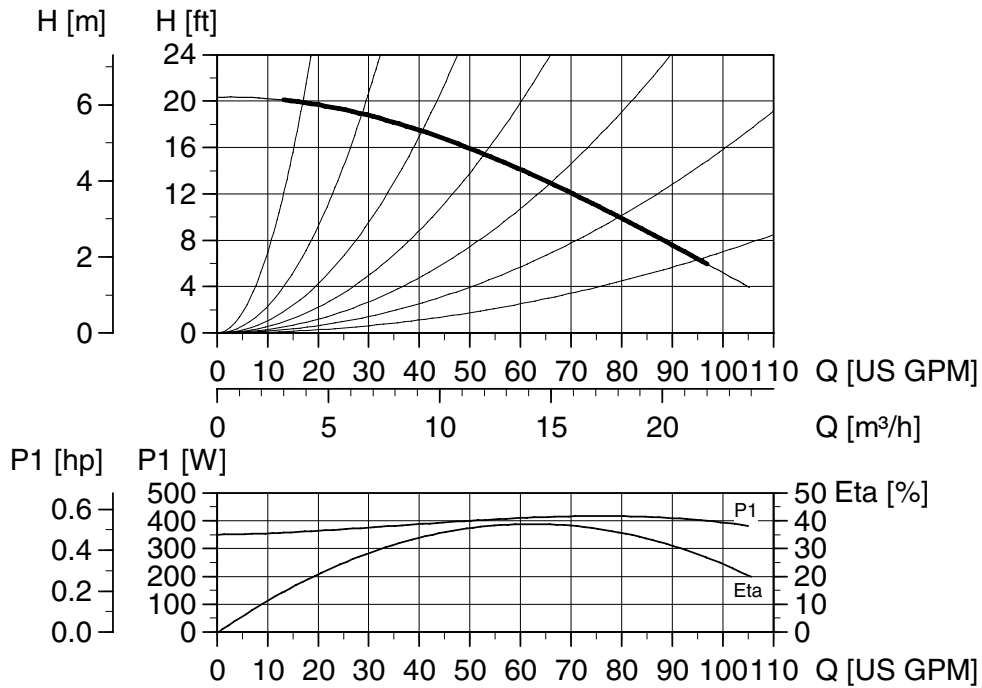

Note: ETA is calculated as wire-to-water efficiency.

Weights and volume

	Cast Iron				Bronze			
	lbs.	ft ³	Kg	m ³	lbs.	ft ³	Kg	m ³
Net weight	44.5		20.2		49.2		22.3	
Gross weight	63.5		23.8		57.1		25.9	
Shipping volume		2.1		0.06		2.1		0.06

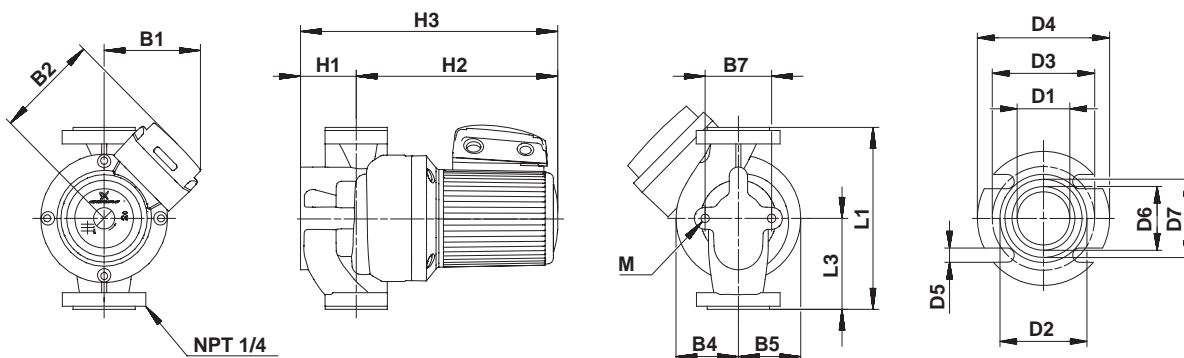

Dimensions

	L1	L3	B1	B2	B4	B5	B7	H1	H2	H3	D1	D2	D3	D4	D5	D6	D7	M
[Inches]	9 7/8	5	5 1/4	5 9/16	3 9/16	2 15/16	4 3/4	2 15/16	9 7/8	12 13/16	2 1/16	4 3/16	5	6	5/8	3 2/4	4	
[mm]	250	127	133	141	91	75	120	75	251	326	53	106	127	152	16	89	101	M12

Packaged fitting sets

	Pump connection	Pipe connection type & size	Material number	Approx. ship. wt. (lb/oz.)	
		NPT			
Flange sets★	Cast iron	GF 15/26 flange	3/4	519601	2 lb 4 oz.
			1	519602	2 lb 4 oz.
			1-1/4	519603	2 lb 2 oz.
			1-1/2	519604	2 lb 2 oz.
		GF 40/43 flange	1-1/2	539605	2 lb 7 oz.
		GF 50 flange	2	96409354	6.5 lb
		GF 53 flange	2	91584910	12 lb
			2-1/2	91584911	12 lb
		GF 65 flange	3	91584912	12 lb
			2-1/2	559601	16 lb
	GF 80 flange	3	569601	19 lb	
	GF 100 flange	4	579801	33 lb	
	Bronze	GF 15/26 flange	3/4	519651	2 lb 2 oz.
			1	519652	2 lb 3 oz.
			1-1/4	96409356	2 lb 1 oz.
			1-1/2	539615	3 lb
		GF 50 flange	2	96409355	6.3 lb
		GF 53 flange	2	91584913	12 lb
2-1/2			91584914	12 lb	
GF 80 flange		3	91584915	12 lb	
		3	569611	20 lb	
GF 100 flange		4	96409357	30 lb	

★ Flange sets include: 2 each - flanges, gaskets, bolts with nuts.

Flange adapter



Terminal box electrical components

For use with these pumps	Description	Material number
1-phase x 115/230 V UPS	Speed plug for 3-speed	96401124
3-phase x 208-230 V UPS		96401001
1-phase x 115 V UPS	Power head relay module	96409246
1-phase x 230 V UPS		96409247
3-phase x 208-230 V UPS		96409250
1-phase x 115 V	Protection module service	96427457
1-phase x 230 V		96427458
3-phase x 208-230 V		96427459

WebCAPS

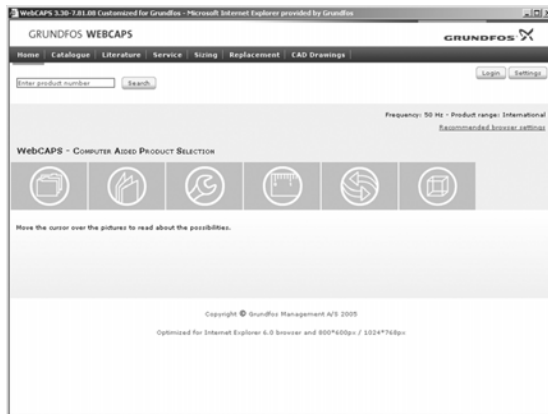

WebCAPS is a **Web-based Computer Aided Product Selection** program available on www.grundfos.com.

WebCAPS contains detailed information on more than 185,000 Grundfos products in more than 20 languages.

In WebCAPS, all information is divided into 6 sections:

- Catalogue
- Literature
- Service
- Sizing
- Replacement
- CAD drawings.

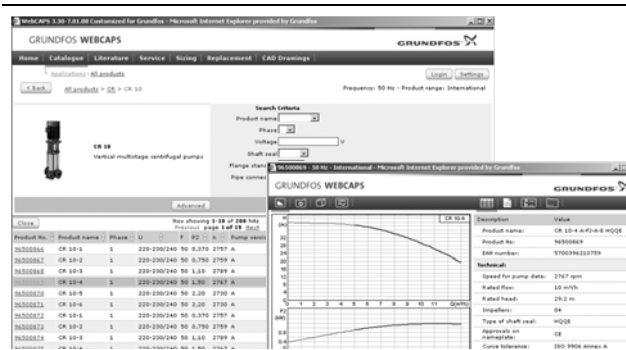

Catalogue

This section is based on fields of application and pump types, and contains

- technical data
- curves (QH, Eta, P1, P2, etc) which can be adapted to the density and viscosity of the pumped liquid and show the number of pumps in operation
- product photos
- dimensional drawings
- wiring diagrams
- quotation texts, etc.

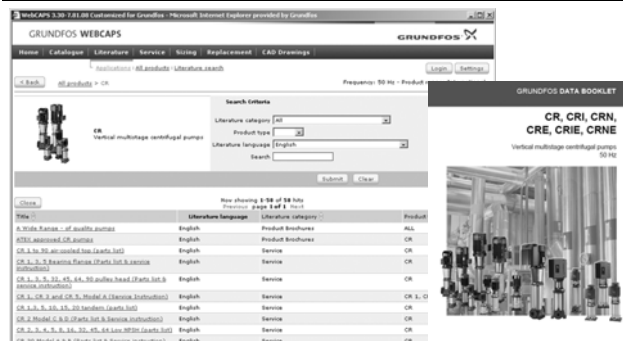

Literature

In this section you can access all the latest documents of a given pump, such as

- data booklets
- installation and operating instructions
- service documentation, such as Service kit catalogue and Service kit instructions
- quick guides
- product brochures, etc.

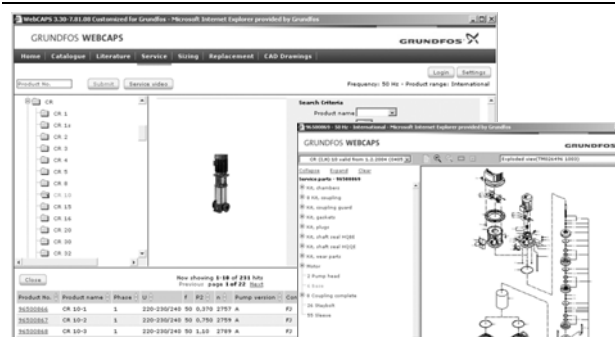

Service

This section contains an easy-to-use interactive service catalogue. Here you can find and identify service parts of both existing and discontinued Grundfos pumps.

Furthermore, this section contains service videos showing you how to replace service parts.



Sizing

This section is based on different fields of application and installation examples, and gives easy step-by-step instructions in how to

- select the most suitable and efficient pump for your installation
- carry out advanced calculations based on energy consumption, payback periods, load profiles, life cycle costs, etc.
- analyse your selected pump via the built-in life cycle cost tool
- determine the flow velocity in wastewater applications, etc.



Replacement

In this section you find a guide to selecting and comparing replacement data of an installed pump in order to replace the pump with a more efficient Grundfos pump. The section contains replacement data of a wide range of pumps produced by other manufacturers than Grundfos.

Based on an easy step-by-step guide, you can compare Grundfos pumps with the one you have installed on your site. When you have specified the installed pump, the guide will suggest a number of Grundfos pumps which can improve both comfort and efficiency.

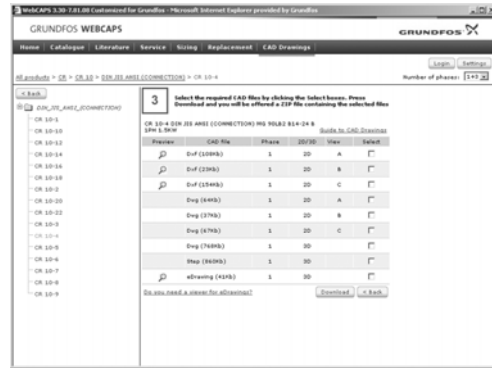

CAD drawings

In this section it is possible to download 2-dimensional (2D) and 3-dimensional (3D) CAD drawings of most Grundfos pumps.

These formats are available in WebCAPS:

2-dimensional drawings:

- .dxf, wireframe drawings
- .dwg, wireframe drawings.

3-dimensional drawings:

- .dwg, wireframe drawings (without surfaces)
- .stp, solid drawings (with surfaces)
- .eprt, E-drawings.

WinCAPS



Fig. 14 WinCAPS CD-ROM

WinCAPS is a **Windows-based Computer Aided Product Selection** program containing detailed information on more than 185,000 Grundfos products in more than 20 languages.

The program contains the same features and functions as WebCAPS, but is an ideal solution if no Internet connection is available.

WinCAPS is available on CD-ROM and updated once a year.