

**ADAPTABLE**



**FLEXIBLE**

**VERSATILE**

# **MODUTEC**

*Simplifying Panel Building*

## **MODDIS** Modular Switchboard Enclosure System

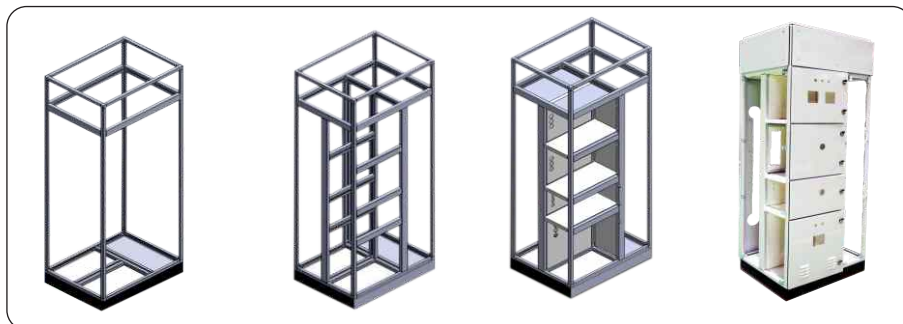

## **MODDRW** Modular Draw Out MCC/PCCs

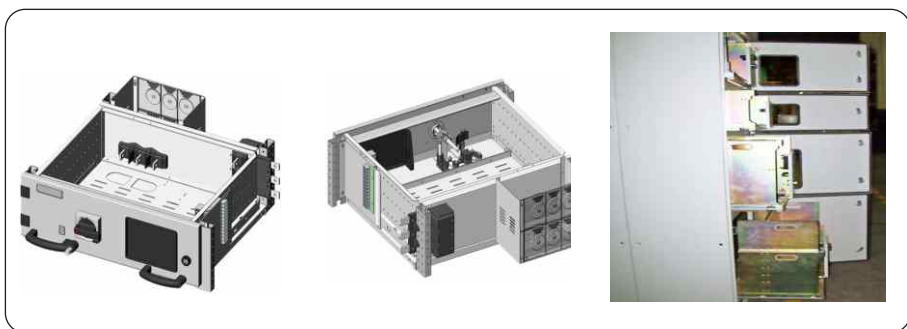

## **MODACC** Panel Accessories

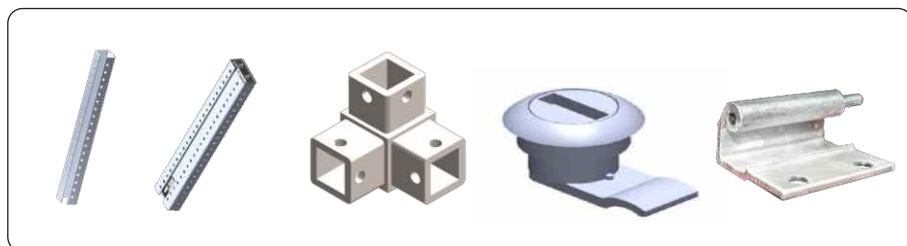

## **MODSIM** Software for Estimation

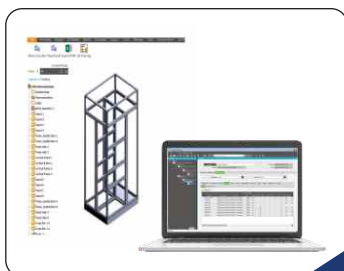

# Modular Switchboard Enclosure System

MODDIS

UPTO FORM 4

MCC & PCC

TYPE TESTED

The growing demand in industry power distribution, building & infrastructure are the important drivers increasing growth in the global electrical enclosure markets.

Globally the government of many countries have implemented stringent regulation regarding safety, compliance to IEC standards & world class quality.

To evangelize this trend and to enable any panel builder to build world class panels in terms of quality, safety & technology, MODDIS leads in empowering ON TIME DELIVERY, LEAD TIME REDUCTION & SIMPLIFICATION.

MODDIS is a system in use since 2000 and has continuously evolved to its present version. It is time tested, trusted & simple to use. These modular enclosures are available in different forms of construction, with a range of accessories & possibilities to address the need of every panel builder in a simple, systematized & standardized manner.

Unlike in other modular enclosures available abroad, with MODUTEC, the Panel Builder can shear (piece) the length of the Frame Bar or Cross Bar into smaller lengths (pieces) as required for use. This tremendously reduces the inventory he has to carry and work never gets constrained for want of a specific length of profile which may not be readily available in his stock (peace of mind). This concept of “Piece – Pieces – Peace” is a Decisive Competitive Edge MODUTEC has.

Every supply of MODULAR enclosures carries an Installation Manual along with detailed technical data. Apart from this, on request, our service engineer can personally support, coach and orient the team at the Panel Builder's location on how best to put the Switchboard together. Videos will be shortly released in this regard and MODUTEC is committed to facilitating scaling your Panel Board business with ease.

## Some of the salient features of MODDIS are as follows:

- Catalogued system of about 5000 parts used to build electrical equipment.
- Very well illustrated assembly manuals
- Based on 60mm increments with possibility to standardize W, H & D
- Modular bolted and Flat Pack system rather than welded enclosures
- With Inventory you are able to start building immediately
- The parts are fastened with metric bolts and screws
- It is possible to change the design while building it
- Build to any size in height, width and depth
- Build an order in multiple locations and it will match at site
- Easy to ship a set of parts a long distance without damage.
- Then assemble in local markets rather than a fixed end product
- You can build front accessible and rear accessible equipment
- Build up to IP54
- Build up to 8500A, 690VAc & Tested to 100kA for one full second
- Tested to IEC 61439-1 & 2 with ASTA, ERDA & CPRI Certifications
- Facilitated by MODSIM a drawing program to give all the parts, based on autocad
- Freedom to choose any electrical component supplier.

## Material:

- Frame work made of 3 Bend Frame Bar of 2mm thick and punched & pierced throughout the length of the profile at alternating intervals of 30mm.
- 4 Bend Cross Bars of 2mm thick then go to add further flexibility to the skeleton structure as required.
- These profiles are made of galvanized sheet steel and Doors are made of CRCA Sheet Steel.
- Doors are made with all around foamed in PU seal to IP 2X & IP 54 and powder coated to RAL 7032 structure finish.
- Partitions are made of Galvanized sheet steel to suitable measurements as required.

## Accessories:

- 4 nos Eye Bolts for lifting
- Base Plinth in 100 / 200 mm versions
- Slotted Din Rails on Door stiffener as required.
- Drawing Pocket (Sheet steel or Plastic)
- Cam Lock with external Lock as required.
- Bus Bar Supports for Cu & Al Bus Bars
- For Al Bus Bars up to 6300A and Cu Bus Bars up to 8500A
- Cu Flexibars of different sizes to suit amps & terminal width requirements
- Type tested as per IEC 61439 Type 1&2 for both Al & Cu bus bar systems
- Type Test Certificates initial pages available as required

## Supply Includes:

- Enclosure with 120 degree hinged door(s), with door reversible feature of LHS to RHS & with versatile stiffener.
- Modular Switchboard Enclosure System to mechanical impact IK 10.
- Gland plate / Cover plate at bottom & with Bolted doors on top.
- Accessories for Switchgears mounting if required.
- Customization if and as required.

## Remarks:

- Type Tested with most leading switchgear manufacturers
- Adaptable to all makes of Switchgear.
- Module doors available in intervals of 60mm in height from 240 till 1860mm
- High levels of internal safety and tested to Form 4 Type 7
- Complaint to Internal Arc Test.
- Time saving as one system for different switchgear makes.
- Fast assembly of Panel parts with standard accessories
- Main Bus Bars can be placed in the top, bottom & middle; & also in front as well as back of Panel as desired.
- This is a License free Modular Switchboard Enclosure System.
- Comprehensive range of solutions for a variety of applications.

# Standard Feeder Chart For MCC

## MODDIS

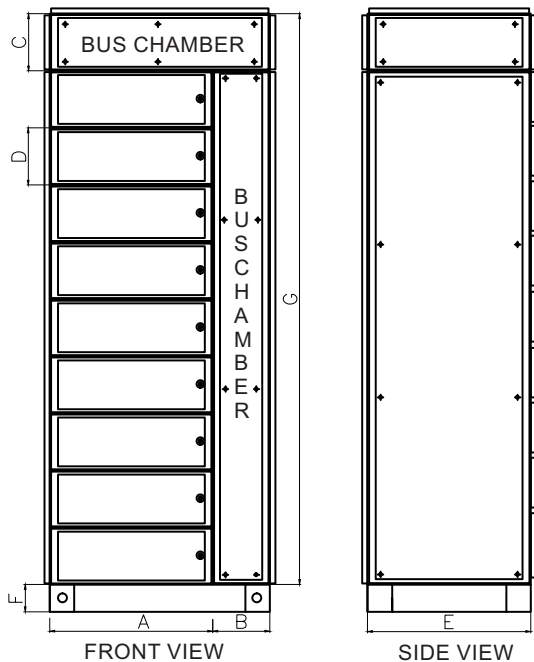

Dimension in mm

SL NO:	A	B	C	D	E	F	G
1	360	300	240	240	360	75	1800
2	480	360	300	300	420	100	1980
3	600	420	360	360	600		2100
4	660		420	420			2220
5	720			480			
6				540			
7				600			
8				720			

**NOTE:**

2 modules one below the other can be merged to form one module, even at site.  
 One large module can be divided into 2 modules as required, even at site.  
 All module compartments have depth adjustable mounting plates.

# Standard Feeder Chart For PCC

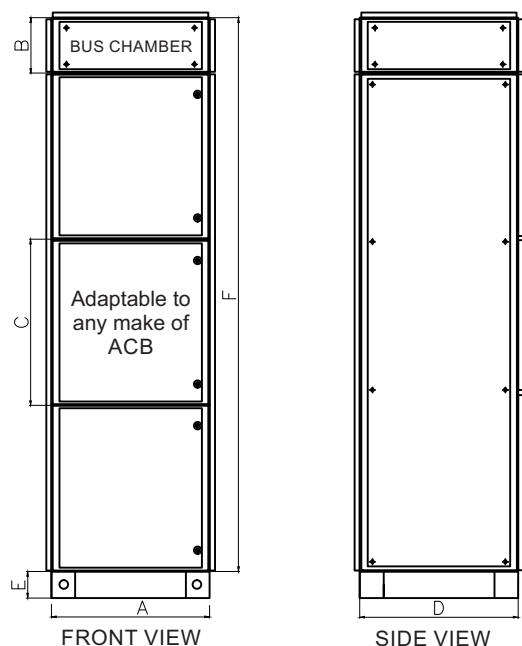

SL NO:	A	B	C	D	E	F
1	600	240	300	840	75	1800
2	660	300	360	960	100	1980
3	720	360	420	1080		2100
4	840	420	480	1200		2220
5	900		540	1320		
6	960		600			
7	1020		720			
8	1200		840			
9			900			
10						

**NOTE:**

ACB modules are available in varying dimensions as in chart below.  
 This can be coupled to a MCC as above with same or varying depth.  
 Cross members placed inside take care of the weight of the ACB and the conveniences of connections.

## Technical Data

### MODDIS & MODDRW

Power Circuit	Up to 550 volts AC, 3 ph. 50 / 60 HZ with or without Neutral
Control Circuit	110 V, 230 V, or any Voltage up to 440 V AC or up to 220 V DC.
Rated Current	Aluminum grade E 91E as per IS:5082 & Electrolytic grade Copper Bus-bars for current rating up to 8500A.
Short Circuit	Bus-bar system designed for 120kA for 1 sec short circuit withstand capability as per IS 8623 and IEC: 61439 (Tested From CPRI Bhopal).
Temperature rise	Panel tested from 800 A to 4000 A from CPRI Bengaluru / ERDA Vadodara as per IS: 8623 and IEC: 61439.
Ambient Temp	Standard -5 to 50 deg C.
Degree of Protection	IP 54 as per IEC-60529 up to 1600 A and IP 42 beyond 1600 A . (Tested From CPRI Bengaluru / ERDA Vadodara).
Bus bar System	TP-E or TPNE or TP2NE.
Paint Shade	RAL-7035, RAL-7032 and 631 as per IS:5 Structure Finish in Standard shade.
Panel Height:	Up to 2220 mm + 100mm plinth.
Panel width:	Up to 1200mm as a proposed standard.
Panel depth:	Up to 1320 mm as a proposed standard.





## THE PARTS THAT MAKE THE WHOLE

### MODUTEC Cross Bar:

A four bend profile that provides for the internal forms of construction as well. It adds to the strength of the Switchboard, as the weight of the Switchgear, Bus Bars etc are taken by this frame that gets built, not the walls as in conventional welded designs. These are available in 2400mm length pieces or in smaller sizes starting from 180mm.

### MODUTEC Hinged Doors:

These come with a double bending on all 4 edges. This adds significantly to the strength, aesthetics & IP clause protection with Neoprene / EPDB gaskets to boot. They are provided with concealed hinges and door locks as required. A special handle arrangement is given on the locks to facilitate easy opening of the door.

### MODUTEC Partition Plate :

These are used to segregate the different compartments width wise, height wise and depth wise. These are used to form barriers, separate live parts from contact to humans and provide for Forms of Construction as per IEC 61439 as required for the given application.

### MODUTEC Fixed Type Compartment:

is useful in building Form 3 & 4 types of construction and their sub forms as per IEC 61439 standard. The beauty of this system is that if for a reason, two compartments would need to be merged into one or vice versa to accommodate a changed Project requirement, this can be facilitated, unlike for welded designs.



### MODUTEC Bolted Doors:

These come in standard sizes and can be customized too. The door bolting arrangement is such that the CSK screws used render the bolted door flush in surface and therefore adds to the look of the switchboard.

### MODUTEC Frame Bar:

A three bend profile that's punched, pierced and tapped so as to make the assembly of the Switchboard quick, while being flexible, adaptable and versatile. The tapped holes are at a pitch of 30mm which renders the system to make Switchboards in multiples of 30mm in the X, Y & Z axis. These are available in 2400mm length pieces or in smaller sizes starting from 180mm.

### MODUTEC Tripod:

This is an aluminum alloy, pressure die cast and helps form the corners of the Switchboard shipping sections. It also aids in the earthing continuity of the Panel line up.

### MODUTEC Plinth Profiles:

These are made out of 2mm Steel and available in heights of 100mm & 200mm or as required. For a given depth & length the respective profile sizes are bolted together to form the base of the Panel. For heavy duty Panels, heavy duty plinths are available. The Plinth profiles are powder coated to black matt finish.

## THE COMPETITIVE FORMULA

### Formula 1:

MODDIS Partial Assembly of Shell only + Client Components + Your Labour = Competitive selling price.

### Formula 2:

MODDIS flat pack parts + Client Components + Your Labour = Competitive Selling price.

MODDIS Partial Assembly of Shell only = MODDIS parts plus Modutec labour.

Client Components is your best solution by technology and/or price. No margins added to components by Modutec

## THE BUSINESS OFFER

**The Strategy:** To give panel builders the tools and ability to build electrical equipment using the Modutec System in their own region.

**Step 1:** Accept the Modutec MODDIS System. The owners of facilities must understand what they are buying for their facility and ask panel builders to build it for them. Panel builders must be able to work with the system and therefore require training.

**Step 2:** Purchase complete MODDIS shell assemblies from Modutec. Invite us to supply some projects in the beginning to see how it works.

**Step 3:** Take training in Modutec MODDIS selection and assembly.

**Step 4:** Import and use signature parts only, from Modutec. Become a System Integrator to Modutec.

## PROFITABLE GROWTH STRATEGY

- Modutec belongs to a Business Group engaged in the Electromechanical Industry since 1983.
- With your small investments in Modutec MODDIS parts, you will be able to participate in large prestigious projects.
- This will help you work on the basis of collaborative and distributed relationships to establish lateral power in the industry.
- You do what you do best, ie Electricals and we do what we do best, ie Mechanicals.
- Your value add will be your knowledge about electrical system application and regional markets.
- You should be able to operate & organize MODSIM drawings for order and construction from electrical single lines.
- Modutec inventory would need to be carried at your end or you will need to source it from your nearest stock point.

- Modutec - is certified to IEC 61439 - 1&2 for Low Voltage and IEC 62271-200 for Medium Voltage with certain brands of Switchgear.
- We have the engineering capability and the enclosure technology to pass these stringent tests for certification.
- There are other Type Tests like IEC 61921 for Capacitor Control Panels, IEC TR 61641 for Internal Arc protection, IEC 60071-2 for Seismic withstand Test and so on.
- We undertake to do these Type Tests & more for Panel Builders & Switchgear Manufacturers as required.

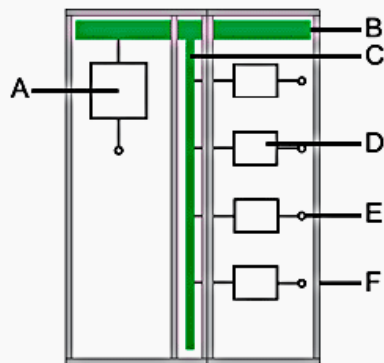

- A = Incoming device
- B = Main busbar
- C = Distribution busbar
- D = Outgoing device
- E = Terminals for external conductors
- F = Enclosure IP2X minimum





# Modular Draw Out MCC/PCCs

MODDRW

AVAILABLE IN 2020

DRAW OUT IN SF & DF

AL OR CU

## Material:

- Frame work made of 3 Bend Frame Bar of 2mm thick and punched & pierced throughout the length of the profile at alternating intervals of 30mm.
- 4 Bend Cross Bars of 2mm thick then go to add further flexibility to the skeleton structure as required.
- These profiles are made of galvanized sheet steel and Doors are made of CRCA Sheet Steel.
- Doors are made with all around foamed in PU seal to IP 2X & IP 54 and powder coated to RAL 7032 structure finish.
- Partitions are made of Galvanized sheet steel to suitable measurements as required.

## Remarks:

- Suitable for most leading switchgear manufacturers.
- Adaptable to all makes of Switchgear.
- Module doors available in intervals of 60mm in height from 240 mm onwards.
- High levels of internal safety and can be made suitable to Form 4 Type 7.
- Design complaint to Internal Arc Test.
- Time saving as one system for different switchgear makes.
- Fast assembly of Panel parts with standard accessories.
- Main Bus Bars can be placed in the top or bottom of Switchboard.
- This is a License free Modular Switchboard Enclosure System.
- Comprehensive range of solutions for a variety of applications.

## Supply Includes:

- Enclosure with 120 degree hinged door(s), with door reversible feature of LHS to RHS & versatile stiffener
- Modular Switchboard Enclosure System to mechanical impact IK 10.
- Gland plate / Cover plate at bottom & with Bolted doors on top.
- Accessories for Switchgears mounting if required.
- Available in Single or Double Front orientations.
- Sliding contacts for control circuits, not plug & socket arrangement.
- With the door closed, the user will be able to rack inn and rack out the module from service to test and to isolated positions.
- Customization if and as required.

## Accessories:

- 4 nos Eye Bolts for lifting
- Base Plinth in 100 / 200 mm versions
- Slotted Din Rails on Door stiffener as required.
- Drawing Pocket (Sheet steel or Plastic)
- Cam Lock with external Lock
- Bus Bar Supports for Cu & Al Bus Bars
- For Al Bus Bars up to 6300A and Cu Bus Bars up to 8500A
- Cu Flexibars of different sizes to suit amps & terminal width requirements

# Modutec Panel Accessories





MODACC

PANEL ACCESSORIES





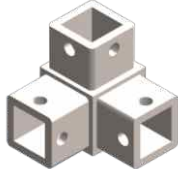

BB INSULATORS

FLEXIBAR

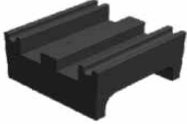

SL.NO	PART CODE	PART DESCRIPTION	PICTURE
1	MODACCFBXXXXX14G	FRAME BAR	
2	MODACCCBXXXXX14G	CROSS BAR	
3	MODACCTPD001XXXX	TRIPOD	
4	MODACCLTC002XXXX	LIFTING CLAMP	
5	MODACCCTC004XXXX	CONNECTOR CHANNEL	

6	MODACCSPR012XXXX	SPACER	
7	MODACCCFB016XXXX	BOLTED COVER FIXING BRACKET	
8	MODACCSHB014XXXX	SINGLE HARDWARE CLAMP	
9	MODACCCPB003XXXX	COUPLING BRACKET	
10	MODACCSGU013XXXX	SIDE GUSSET	
11	MODACCSGU011XXXX	DOOR LOCKS & LIP	
12	MODACCHGB005XXXX	DOOR HINGE & HINGE PIN	
13	MODACCHBU009XXXX	HINGE BUSH	
14	MODACCLLL010XXXX	LOCK LATCH	
15	GCSW06012ATCXXXX	M6X12 ALLEN 8.8grade SCREW	

16	GCSW06015ATCXXX	M6X15 ALLEN 8.8grade SCREW	
17	MODACCBSMXXXXXXXX	Busbar supporting channel (MS)	
18	MODACCSMI047XXXX	SMC Insulator MT-047	
19	MODACCPLMXXXXXXXX	Pultruded rod MS	
20	MODACCPLEXXXXXXXXX	Pultruded rod Epoxy	
21	MODACCDMCXXXXXXXX	DMC Conical support	
22	MODACCFBXXXXXXXX	Flexible Copper bar	

**NOTE:** Many more Panel accessories of standard, aesthetic and user friendly varieties are being continually added to our range. So please state your requirements and we shall strive to serve you appropriately.

MOD SIM Panel designer is an software based program and easy for you to design your panel exactly the way you want and make the estimation with the detailed bill of material .

Also the software is being designed to convert BOM in to CAD & CAM output to feed in to the CNC machine for manufacturing.

Users are having freedom to construct modular enclosures with few standard accessories & for unrestricted makes of switchgear.

MODSIM is Modutec's under construction version of planning and configuration software for type-tested low-voltage switchgear of their MODDIS systems. The software will offer quick and easy generation of quotations and bill of materials with better assembly information and the capability to view the side of the assembly, where part numbers and their location within the system are indicated.

Software will include project handling that ranges from an automatic generation of bill of materials via price determination up to material ordering CAD & CAM output. By means of comprehensive import and export functions it will be possible to add third party products, required for distribution, to the software database. Special enclosure designs will be optionally stored in the software as own field types.

Comprehensive help functions will lead the user through the programme and explain the necessary steps. When entering some parameters, bill of orders and drawings will be generated for individual field types. The user will be able to add further Modutec products or other articles from a pre-created article master at any time during field configuration.

After configuration of the individual fields a CAD view would automatically be displayed, printed or exported if required. The generated bills of materials, whose content can be freely generated, could be optionally printed or exported as a file.

In the next version of MODSIM, the CAD file would be converted to CAM so as to feed the System Integrator's CNC Turret Punch Press with ease.

Included alongside the bill of materials will be new technical brochures, tightening torques for bus bar systems and Assembly Instructions for MODDIS low voltage modular switchboard enclosure systems.

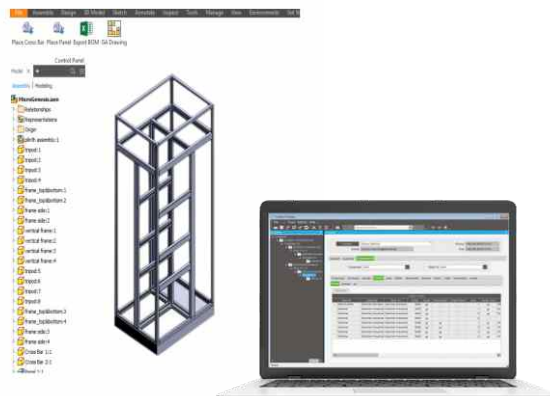



- Being Panel Builders ourselves in our sister company, we understand how enclosures are engineered.
- Our team listen to every enclosure solution requirement and guide the Customer in how and if Modutec can be the answer for their simplifying, systematizing and scaling their business.
- They will then assist the Panel Builder in their shop floor to train their workers and supervisors in the best practices, processes and methods of putting the Modutec modular enclosures together.
- Online training is also available

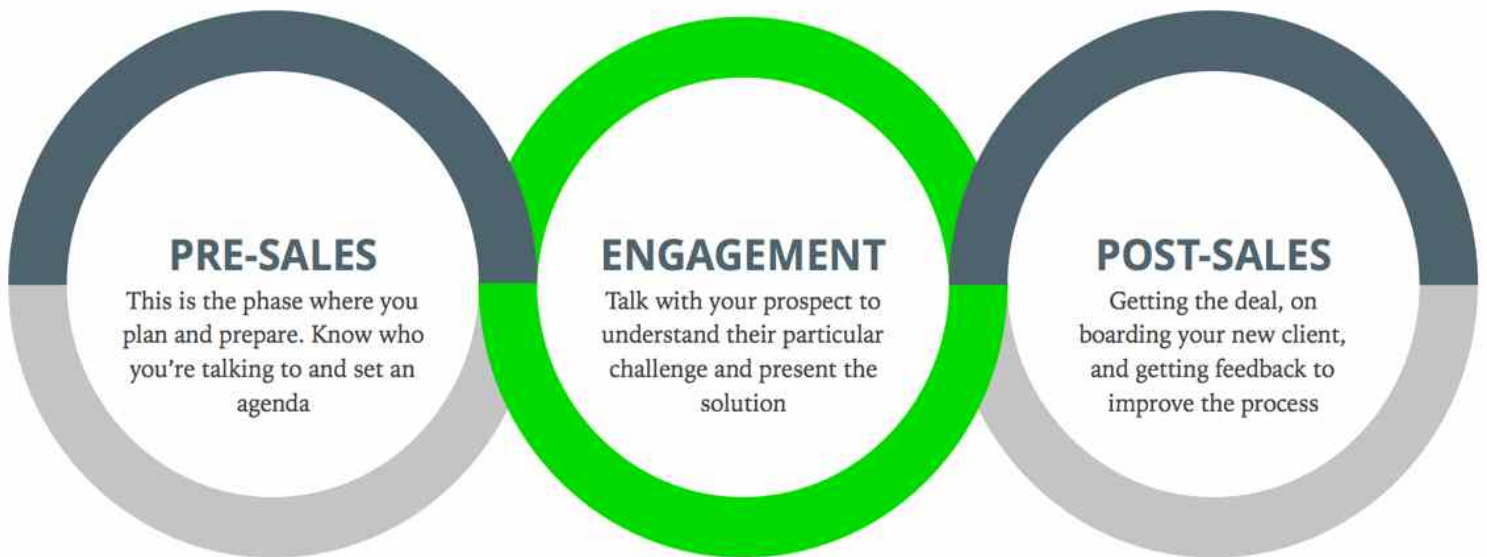

STANDARDIZED

SYSTEMATIZED

HELPS YOU SCALE



Modutec Ready Panels Pvt.Ltd  
No. 3, K.Ashwath Industrial Estate, Uttari  
Road  
Kaggalipura, Off Kanakapura Road

+91 97318 77444 , +91 99014 59624, +91 98450 40837

modular@modutec.net

Please state the nature of your request.  
If you require pricing for parts or partial assemblies please provide a specification and drawing in Adobe PDF or Autocad (version 2010 or earlier) and your required response date.  
Please provide your company name, position, address and phone number.

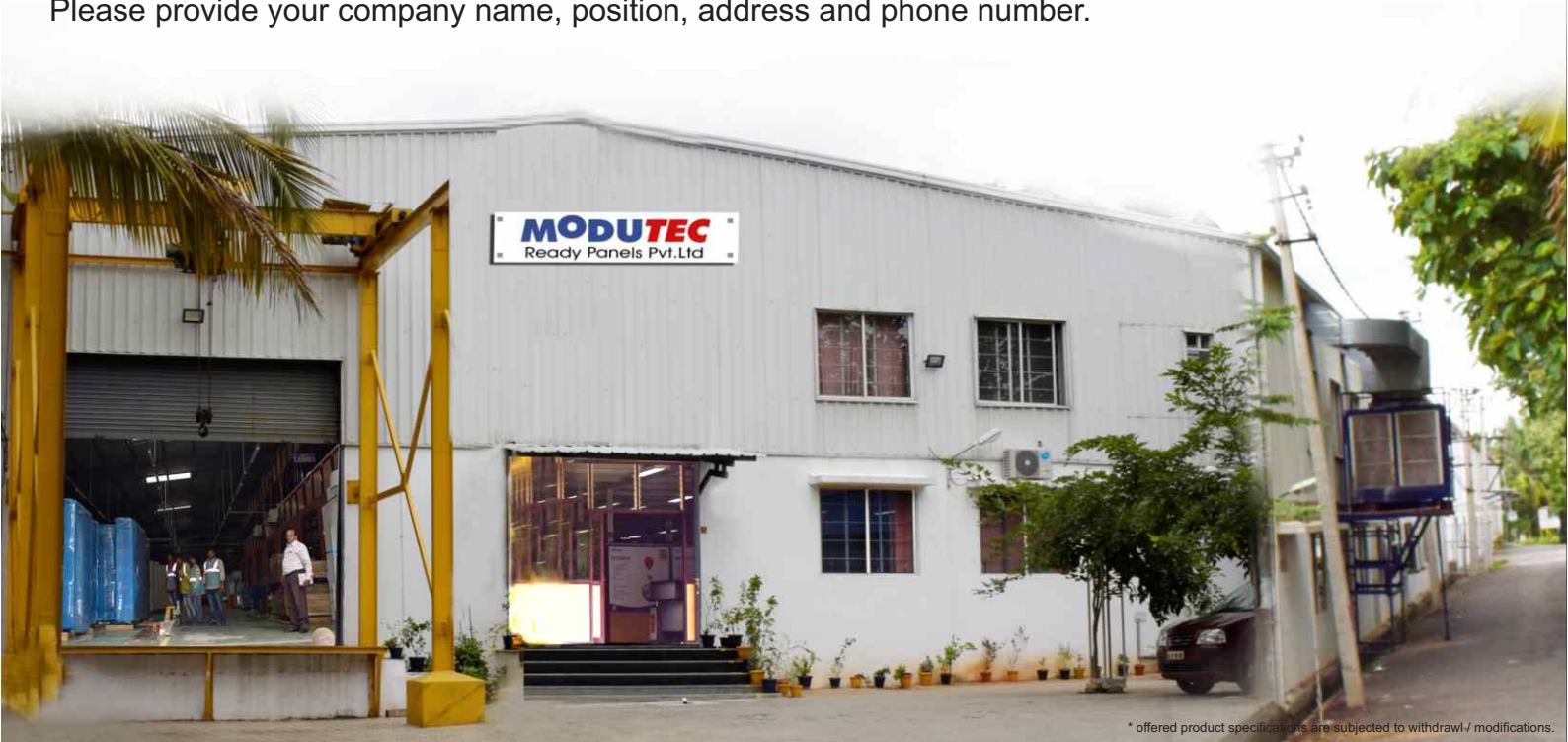

\* offered product specifications are subjected to withdrawl / modifications.