

# VERTICAL TURBINE OEM MANUAL



[WWW.HYDROFLOPUMPS.COM](http://WWW.HYDROFLOPUMPS.COM)





## STANDARD TERMS AND CONDITIONS

1. **Entire Contract** – This document represents the entire contract between the parties and which may not be amended, modified or rescinded, except by written agreement signed by an authorized representative of Seller, which expressly refers to this document. The Seller hereby objects to any conflicting or additional terms or conditions contained in Buyer's documents. This Purchase Order constitutes an offer and not an acceptance of any offer from Buyer. Buyer shall be deemed, at Seller's option, to have accepted this offer within the earlier of 10 days after receipt or upon the manufacture, fabrication, provision or delivery of any goods or services contemplated or upon Buyer's execution of this document. Seller may, at any time, correct any mathematical or clerical errors contained herein.
2. **Prior Sale, Inventory** - All goods are offered subject to prior sale and/or availability of current inventory and Seller shall have no liability whatsoever from a failure to provide goods because of prior sale or unavailability.
3. **Prices** - Unless otherwise specified herein, prices noted on the face of this document are firm for thirty (30) days, provided, however, that if, before shipment of this order, Seller should receive increases from its manufacturers or suppliers, Seller may adjust the above price to those in effect at time of shipment without notice.
4. **Delays** - Whether or not due to Seller's fault, Seller shall not be responsible for any failure or delay in delivery due to fires, floods, labor trouble, breakdowns, delay of carriers, manufacturers delay, total or partial failure for any reason of sources of supply or transportation, requirements, or requests of any government or subdivision thereof, or any similar or dissimilar cause beyond the Seller's direct control. In the event of inability of the Seller, for any cause beyond Seller's direct control, to supply the total demands for any materials specified in this order, Seller may allocate its available supply among any or all buyers on such basis as Seller, in its sole discretion, may decide without liability for any failure to perform the contract. SELLER SHALL IN NO EVENT BE LIABLE FOR ANY CONSEQUENTIAL OR INCIDENTAL DAMAGES WHATSOEVER RESULTING FROM ANY FAILURE OR DELAY IN DELIVERY, WHETHER OR NOT FROM CAUSES BEYOND SELLER'S DIRECT CONTROL.
5. **Payment and Credit** – Shipment, deliveries and performance of work shall at all times be subject to the approval of the SELLER'S credit department. Invoices submitted by Seller under this order are payable at par in legal tender of the United States of America in the city designated in the remittance address, upon the payment terms and in the amounts herein set forth. Whenever reasonable grounds for insecurity should arise with respect to due performance by the Buyer, Seller may demand different terms of payment from those specified on the face of this order and may demand satisfactory security for the performance of Buyer obligations. Seller may, upon making such demand, suspend shipments hereunder. If, within the period stated in such demand, Buyer fails or refuses to agree to such different terms of payment, or fails or refuses to give adequate security for due performance, Seller may, at its option, treat such failure or refusal as a repudiation of any portion of order which has not been fully performed. AS LIQUIDATED DAMAGES AND NOT AS A PENALTY, BUYER SHALL BE OBLIGATED TO PAY ON ALL ACCOUNTS NOT PAID ON THE DUE DATE THEREOF THE LOWER OF (I) 1-1/2% PER MONTH ON THE OUTSTANDING ACCOUNT BALANCE OR (II) THE HIGHEST RATE PERMITTED BY LAW TOGETHER WITH ALL ATTORNEYS' FEES INCURRED BY SELLER IN CONNECTION WITH THE COLLECTION OF ANY DELINQUENT ACCOUNTS. Buyer agrees that notwithstanding any endorsements or legend appearing on Buyer's checks, drafts or other orders for payment of money, they do not, solely because of such endorsement of legend or otherwise, constitute payment in full or settlement of the account. No failure of the Seller to exercise any right, accruing from any default of the Buyer, shall impair Seller's right in case of that or any subsequent default of the Buyer.
6. **Standard, Tolerance** – Except in particulars specified by the Buyer expressly agreed to in a writing signed by Seller, the goods furnished hereunder are produced in accordance with standard manufacturing practices at the country of origin. All materials are subject to manufacturing tolerances and variations, consistent with normal manufacturing practice with respect to dimension, weight, straightness, section, composition and mechanical properties, normal variations in surface and internal conditions and in quality to deviations in tolerances and variations consistent with practical testing and Seller is not responsible for any deterioration in quality which may result from processing, operations or use by the Buyer.
7. **Changes** - Orders may not be canceled or changed except with Seller's written consent and upon terms that will indemnify the Seller against all loss. Postponement of delivery will not be made without Seller's approval first being obtained. Seller assumes no responsibility for any changes in specifications unless such changes are accepted in writing by Seller. Any price increases resulting from such changes shall become effective immediately upon the acceptance of such changes.
8. **Delivery; Discounts** - Delivery terms are as stated on the face of this document. Unless indicated otherwise on the face of the document, all shipments are made F.O.B. Shipping Point. Freight will be allowed on delivered prices only to the extent set forth on the face of the invoice. Cash discounts provided for in this order shall apply only to the discount value as indicated on the face of the invoice. In the case of pick up by the Buyer, Buyer's truck is destination and Seller will not deliver or bear any cost of shipment or transportation or make any allowance with respect thereto. Seller will in no event be responsible for spotting, switching, drayage or other local charges in destination.
9. **Inspection; Waiver** - Where Buyer is to inspect, inspection and acceptance must be made within ten days of receipt. Any and all claims relating to this transaction which Buyer may have against Seller must be filed in a court or competent jurisdiction within 1 year after delivery or shall be forever barred and waived.
10. **Warranty and Limitation of Remedies** - Each product manufactured by Hydroflo Pumps USA, Inc. is warranted to be free of defects in material and workmanship for one (1) year after the product is first put into operation or eighteen (18) months after the date of shipment, whichever is less, when the product is in the hands of the original owner and the product has been used properly for the purpose which sold; and provided that Seller shall be notified within thirty (30) days from the earliest date on which an alleged defect could have been discovered, and further that the defective good(s) or part(s) shall be returned to the Seller, freight prepaid by such user, at Seller's request. No material will be accepted at Seller's plant without a Return Material Authorization (RMA) number first obtained from Seller. All material returned must be clearly marked with such RMA number. Unless expressly stated otherwise, warranties in the nature of performance specifications furnished in addition to the foregoing on a product manufactured by Hydroflo Pumps USA, Inc., if any, are based on laboratory test corrected for field performance. Due to inaccuracies of field-testing, if any conflict arises between the results of field testing conducted by or for the user, and laboratory tests corrected for field performance, the latter shall control. No equipment shall be furnished on the basis of acceptance by results of field testing. Upon receipt of definite shipping instructions from Seller, Buyer shall return all defective goods to Seller after inspection by Seller. The goods returned must be returned in the same conditions as when received by the Buyer. Defective goods so returned shall be replaced or repaired by the Seller without an additional charge or, in lieu of such replacement or repair, Seller may, at its option, refund the purchase price applicable to such defective goods. Seller agrees to pay return transportation charges not exceeding those which would apply from original destination on all defective goods. However, Seller shall not be liable for such charges when the goods are not defective and Buyer shall be liable for such charges. SELLER'S LIABILITY SHALL BE LIMITED SOLELY TO REPLACEMENT OR REPAIR, OR AT SELLER'S OPTION, TO REFUNDING THE PURCHASE PRICE APPLICABLE TO DEFECTIVE GOODS OR SERVICES. SELLER SHALL IN NO EVENT BE LIABLE FOR ANY CONSEQUENTIAL OR INCIDENTAL DAMAGES. THIS WARRANTY IS IN LIEU OF AND EXCLUDES ALL OTHER WARRANTIES, GUARANTEES OR REPRESENTATIONS, EXPRESS OR IMPLIED BY OPERATION OF LAW, INCLUDING ANY WARRANTY OF MERCHANTABILITY OF FITNESS FOR A PARTICULAR PURPOSE. SELLER SHALL HAVE NO LIABILITY ARISING FROM DESIGN FURNISHED BY OTHERS OR FROM ENGINEER'S OR ARCHITECT'S ERRORS OR OMISSION.
11. **Taxes** - Buyer shall be liable for all taxes of any sort now or hereafter imposed by any federal, state, municipality or other government agency that may be levied against this transaction.
12. **Source of Materials** - Unless otherwise expressly agreed to in a writing signed by Seller, Seller has the right to obtain material from any source at its discretion.
13. **Delivery Date** - The scheduled delivery dates shall be, not be earlier than a time reasonably convenient to Seller after, if applicable, final drawing approval.
14. **Patents** - If any goods shall be sold by Seller to meet Buyer's specifications or requirements and is not a part of Seller's standard line offered by it to the trade generally in the usual course of Seller's business, Buyer agrees to defend, protect and save harmless Seller against all suits at law or in equity and from all damages, claims and demands for actual or alleged infringement of any United States or foreign patent and to defend any suits or action which may be brought against Seller for any alleged infringement because of the sale of any such material.
15. **Waivers** - No waivers by the Seller of any breach of any provisions hereof shall constitute a waiver of any other breach of such provision. Seller's failure to object to provisions contained in any communication from the Buyer shall not be deemed an acceptance of such provisions or as a waiver of the provisions of this document.
16. **Timing of Billing to Buyer** - Seller will invoice Buyer upon shipment from its supplier or facility, unless otherwise indicated on the face of this document.
17. **Storage of Material for Buyer** - If, at Buyer's request, goods covered by this document are held at Seller's facility or service provider for more than 21 days after they are available for shipment, Buyer shall accept Seller's invoice and pay said invoice based on payment terms set forth herein.
18. **Material Reservation** - Seller will only reserve material for 30 days with receipt of an executed purchase order, quote or order acknowledgement acceptable to Seller. After that time, material availability, price and shipment date may be adjusted, at Seller's option.

---

## TABLE OF CONTENTS

	PAGE #
<b>1. INSTALLATION.....</b>	<b>1-10</b>
1-1 Receiving, Uncrating, and Inspecting.....	1
1-2 Installation Equipment and Tools.....	1
1-3 Special Precautions.....	1
1-4 Preparation and Cleaning.....	1
1-5 Installation.....	2
<b>2. STORAGE.....</b>	<b>10</b>
2-1 Considerations.....	10
2-2 General Hints.....	10
2-3 Short Coupled Pumps.....	10
2-4 Miscellaneous Items.....	10
<b>3. BOWL DISASSEMBLY AND ASSEMBLY.....</b>	<b>11-12</b>
3-1 Bowl Disassembly.....	11
3-2 Bowl Assembly.....	11
<b>4. OPERATION.....</b>	<b>13</b>
4-1 Prior to Start Up.....	13
4-2 Initial Start Up.....	13
4-3 Routine/Normal.....	13
4-4 Shutdown/Emergency.....	13
<b>5. FIELD TESTS.....</b>	<b>14-15</b>
5-1 Field Tests.....	14
5-2 Downthrust.....	14
5-3 Shaft Stretch.....	15
<b>6. ENGINEERING.....</b>	<b>16-18</b>
<b>7. MAINTENANCE.....</b>	<b>19-22</b>
7-1 General.....	19
7-2 Bearing Replacement.....	19
7-3 Wear Ring Replacement.....	19
7-4 Packing Replacement.....	20
7-5 Preventive Maintenance.....	22
<b>8. TROUBLE SHOOTING.....</b>	<b>23-25</b>
8-1 Trouble Shooting.....	23
8-2 Impellers.....	24
8-3 Bearings.....	24
8-4 Shaft and Couplings.....	25
8-5 Bowls.....	25
8-6 Packing Box.....	25
8-7 Inner Column.....	25
<b>9. ORDERING PARTS.....</b>	<b>26</b>
<b>10. PUMP DRAWINGS/PERFORMANCE.....</b>	<b>INSERT</b>
<b>11. MOTOR MANUAL.....</b>	<b>INSERT</b>

## 1. INSTALLATION

---

It is important that you read and understand all the installation instructions prior to beginning the installation of the unit.

### 1-1. RECEIVING, UNCRATING, AND INSPECTING

- A. Using the packing list as a guide, make certain that all equipment arrived in the shipment and inspect for obvious damage incurred during shipment.
- B. Immediately report any damage to carrier.
- C. Uncrate and lay out all the equipment in the order of installation on clean boards or floor.

### 1-2. INSTALLATION EQUIPMENT AND TOOLS

The following is a checklist of tools and equipment needed for the installation. Assemble prior to starting the installation.

- ( ) 1. A portable or permanent derrick of sufficient strength to safely lift the total weight of the pump. A conservative weight for the pump will be listed on the freight bill. The minimum travel of the derrick should be at least 6' greater than the longest piece of pump equipment. Hoist must have swivel hook.
- ( ) 2. One or two cable slings of sufficient strength to lift the entire pump and long enough to clear greatest shaft projection.
- ( ) 3. One erector sling for lifting the driver.
- ( ) 4. Dial indicator calibrated in .001" divisions with a stand.
- ( ) 5. SAE 10 viscosity, low cold pour point mineral oil if pump is to be oil lubricated.
- ( ) 6. Wire brush, paint brush, three-cornered file, flat file, and emery cloth.
- ( ) 7. Set of mechanic's tools including an assortment of socket wrenches.
- ( ) 8. Bucket of solvent, coal oil or naphtha, etc.
- ( ) 9. Machinist's level
- ( ) 10. Steel tape measure.
- ( ) 11. Two pipe wrenches of sufficient size to handle shaft and couplings. (Always required for hollow shaft drive).
- ( ) 12. One set of steel clamps to fit the pump bowl.
- ( ) 13. Two sets of steel clamps to fit the column pipe. **NOTE:** One set is required if only one section of column is furnished with the pump assembly.
- ( ) 14. Two 4 x 4 timbers or "H" beams (if the unit is extra large and heavy). Long enough to span the installation opening.
- ( ) 15. Two "V" blocks for checking shaft straightness.
- ( ) 16. Two chain tongs of sufficient size to handle column pipe.
- ( ) 17. 15' of 3/4" rope.
- ( ) 18. Thread compound and gasket compound with thinner.
- ( ) 19. Two pipe wrenches of sufficient size to handle oil tube if pump is to be oil lubricated.
- ( ) 20. Sufficient quantity of wedges to level discharge head or foundation plate (if applicable).
- ( ) 21. Sufficient quantity of top quality non-shrink grout.
- ( ) 22. Teflon Paste compound for stainless threads, anti-seize compound for the other threads.
- ( ) 23. Bundle of cleaning rags.
- ( ) 24. Putty knife.

### 1-3. SPECIAL PRECAUTIONS

- A. Make certain that no rags, wood scraps, etc., are lodged in any exposed openings. Check pit depth and anchor bolt Spacing with pump dimensions. Lift and handle unit carefully to prevent bending strain damage caused by the hanging weight of the unit. Do not lift any item by the shaft. Take extra precautions when handling a mechanical seal or packing gland assembly since this is a delicate and precision component.
- B. **ALWAYS USE THREAD COMPOUND ON SHAFT AND COLUMN JOINTS.** Do not allow pipe compound, Solvent, or any petroleum products to get on the rubber bearings.
- C. Shaft threads are usually left hand; column threads are right hand. ***If unit is shipped assembled, and has threaded Column pipe; pipe joints may have loosened during shipment. Before installation check threaded connections for tightness. A chain tong pipe wrench should be used to verify tightness of pipe connections.***

### 1-4. PREPARATION AND CLEANING

- A. Clean all threads and flange faces with a wire brush or paint brush and solvent. If required, clean threads with a three-cornered file. The protective coating on the threads and flanges is a rust preventive and not a thread compound or gasket material.

## 1. INSTALLATION

---

- B. Clean all shafts and couplings with a rag soaked in solvent. Make certain that all bearings are clean.
- C. If applicable, remove protective caps from ends of oil tubing and clean all tubing threads and shaft bearings thoroughly with solvent. Make certain tubing faces are free of nicks, dents, and burrs.
- D. Remove gland assembly from discharge head. Remember to be very careful with this item.
- E. Make a physical check of the discharge head or foundation plate for proper fit to foundation.
- F. Check pipe and oil tube ends and couplings to be sure there are no dents, nicks, or burrs.
- G. Check shaft end for nicks, burrs, etc. The shaft alignment is dependent on the point of the shaft ends.
- H. Check all boxed shafting for straightness using "V" blocks and dial indicator as follows:
  - 1. Start with "V" blocks as close to the threads as possible. Check two or more places between "V" blocks and straighten shaft to within .003" to .005" of the Total Indicated Run-Out. Straightening may be performed by mechanical or high pressure on the high point.
  - 2. Move one "V" block about 20% of shaft length inward from the end. Check between the "V" blocks and the overhanging ends; straighten as in step 1 above.
  - 3. If straightening was required in Step 2 repeat Step 1. Repeat the above steps until shaft checks within tolerance in both positions. Wipe the shaft clean after checking.
- I. Check run-out on bowl shaft extensions by placing dial indicator toward the end of the shaft and turning slowly making certain the shaft stays to one side of the upper most bowl bearing. Total Indicating Run-Out should not exceed .005".
- J. Check and record the total bowl lateral or end play. If prime mover is solid shaft, this information will be required for Flanged coupling assembly

### 1-5. INSTALLATION INSTRUCTIONS

#### A. FOUNDATION PLATE (IF SUPPLIED)

- 1. Place foundation plate over anchor bolts and allow to rest on foundation. Full contact with foundation is important for vibration free operation.
- 2. If the final elevation of the plate is critical, this should be checked at this time.
- 3. Attach hex nuts to anchor bolts and turn until snug against foundation plate to protect the anchor bolt threads.
- 4. The foundation plate serves as a good surface for the the foundation. See Illustration 1.1

#### B. PUMP BOWL

- 1. Place the two beams on the foundation plate or foundation opening.
- 2. Secure the proper clamp to the upper end of the bowl beneath a convenient shoulder. If only one sling is used, Attach the sling to the clamps far enough out on the ears to allow for easy removal after setting the unit down on the beams.
- 3. Hoist the bowl to a vertical position using the derrick. If the bowl is equipped with a strainer, do not drag the strainer across the floor.

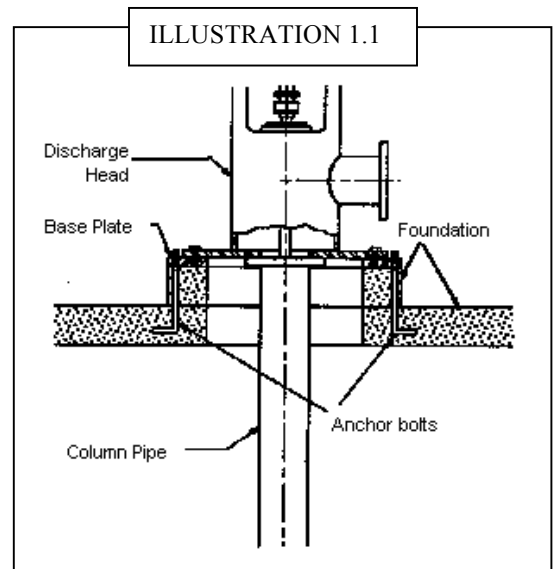

## 1. INSTALLATION

4. If there is any auxiliary piping to the bowl bearing or the thermo-wells, make certain the bowl portion of the piping is attached to the bowl at this time.
5. Center the bowl over installation opening then carefully lower until the clamp ears are resting squarely on the beams. Remove the sling.
6. Clean the following items: shaft threads, discharge threads, flange face (if applicable), threads and face of oil tubing (if applicable). Lightly oil the shaft threads and screw the coupling on half way. Place a rag over the coupling to prevent entrance of foreign matter during the next step in assembly.

### C. COLUMN OPEN LINESHAFT

Refer to the installation plan or the overall dimension sheet of the submittal to determine correct sequence for installation of column lengths.

1. Secure pipe clamp immediately beneath column coupling. If column is flanged, insert bolts and secure clamp below bottom of flange. Clamp should keep bolts in position. See Illustration 1.2.
2. Slide the lineshaft into bottom of column pipe and allow it to extend approximately 15" below the bottom end of the pipe. Make certain the sleeve area of the lineshaft (if applicable) is toward the top of the pipe. Tie a series of half hitches to the column pipe and lineshaft with  $\frac{3}{4}$ " rope. (Tie the rope to a chain pipe vise on the lineshaft, if needed.) Attach the sling to the clamp ears as described under Section B, Step 3.

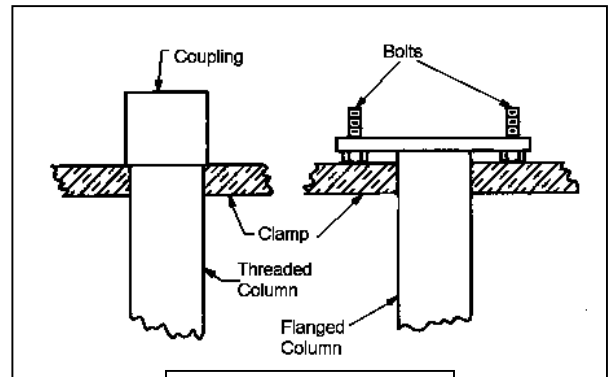

3. Hoist column and lineshaft to a vertical position with the derrick. Do not drag shaft across the floor. Before centering column over bowl, tap the side of column to remove any loose matter.
4. Position the column and lineshaft over the bowl. Align the lineshaft and remove the rag from the bowlshaft coupling. Lightly oil the threads. Lower until the lineshaft contacts coupling. Remove the rope. Hold coupling and turn the lineshaft (left hand threads) until the shaft ends butt up. Place one pipe wrench on the coupling and one on the lineshaft. Tighten securely. Remove the wrench marks from the shaft and coupling with a flat file and emery cloth.

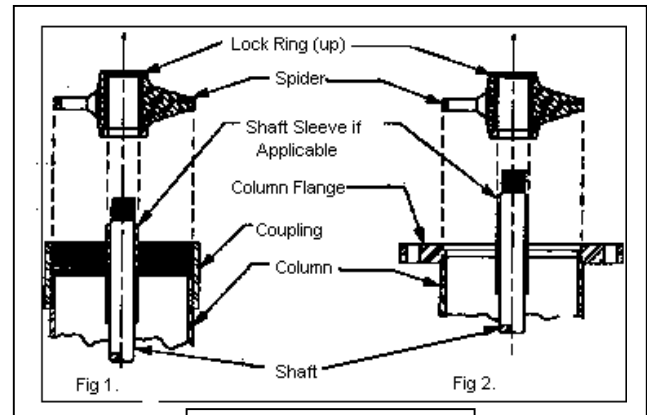

5.
  - a. If bowl to column connection is threaded, apply thread compound to the pipe threads. Attach chain tongs to bowl and to column for support. Lower the column pipe, and at the same time, turn the pipe until it seats against the mating shoulder on the bowl. Tighten pipe into bowl securely.
  - b. If bowl to column connection is flanged, spread a thin, even film of gasket compound on the bowl discharge flange. Lower pipe and align studs in the bowl with the holes in the flange. Seat the column flange against bowl flange. Install and tighten hex nuts evenly.
6. Hoist assembly enough to remove the clamp on the bowl assembly.

## 1. ILLUSTRATION

---

7. If there is any auxiliary piping to bowl bearing or thermo-well being used, that portion that attaches to the column section should now be installed. Also, if the bowl and column are coated with any special coating, any required patch work should be done before lowering unit.
8. Slide beams in close to column. Lower the assembly and rest the clamp ears on the beams. Remove the sling.
9.
  - a. *If there is more than one section of threaded column*, a centering spider may be used. Slip the spider over the lineshaft with lock ring on top (if rubber bearings are used). Screw the centering spider into the column coupling until it butts against the column pipe. See Illustration 1.3, figure 1.
  - b. *If column is flanged*, clean flange and the O.D. of the spider. Slip the spider over the lineshaft with lock ring on top (if rubber bearings are used) and seat into spider recess. See Illustration 1.3, figure 2.
10. Clean all lineshaft threads and faces thoroughly. Screw the coupling on half of its length. Cover the coupling with a rag to prevent foreign matter from dropping into the entrance.
11. If there is more than one section of column, repeat Section C, steps 1 through 10, for each additional section until all of the column is assembled. Clean the thread/flange face of the column pipe and the lineshaft projection thoroughly. Do not attach the shaft coupling to the top piece of shaft.

## D. COLUMN ENCLOSED LINESHAFT

1. Secure pipe clamp immediately beneath column coupling. If column is flanged, insert bolts and secure clamp below bottom of flange. Clamp should keep bolts in position.
2. Slide the correct tubing section with shaft into the column pipe. Allow the tubing to extend six inches below the bottom end of the pipe. Allow the shafting to extend about six inches beyond the bottom end of the oil tube assembly. With the  $\frac{3}{4}$  inch rope, tie a series of half hitches to the pipe, to the tubing and then to the shaft. A chain pipe vise may be used on the shaft, if needed. Attach the sling to the clamp. Leave room for removal of the sling while the clamps are resting on the beams in the following steps.
3. Hoist column to the vertical position with the rope and derrick. Do not drag the shaft across the floor. Before Centering column over bowl, tap side of column to remove any loose matter.
4. Position the column and lineshaft over the bowl. Align the lineshaft and remove the rag from the bowl shaft coupling. Lightly oil the threads. Lower until the lineshaft contacts coupling, then remove the rope. Hold coupling and turn the lineshaft (left hand threads) until the shaft ends butt up. Place one pipe wrench on the coupling and one on the lineshaft. Tighten securely. Remove the wrench marks from the shaft and coupling with a flat file and emery cloth.
5. Lower assembly until tubing contacts the lineshaft bearing, then remove the rope. Apply a small amount of thread Compound to the upper bearing threads. Make certain not to get any thread compound on the faces of the oil tubes. Place one pipe wrench on the stick-up tube of the bowl assembly and one wrench on the oil tube assembly in the column pipe. Align vertically and tighten. If the oil tubing is coated with any special application, any touch-up required resulting from using the pipe wrench should be done now.
6.
  - a. *If the bowl to column connection is threaded*, apply thread compound to the pipe threads. Attach chain tongs to bowl and to column for support. Lower the column pipe, and at the same time, turn the pipe until it seats against the mating shoulder on the bowl. Tighten pipe into bowl securely.
  - b. *If bowl to column connection is flanged*, spread a thin, even film of gasket compound on the bowl discharge flange. Lower pipe and align studs in the bowl with the holes in the flange. Seat the column flange against bowl flange. Install and tighten hex nuts evenly.
7. Hoist assembly enough to remove the clamp on the bowl assembly.
8. If there is any auxiliary piping to bowl bearing or thermo-well being used, that portion that attaches to the column section should now be installed. Also, if the bowl and column are coated with any special coating, any required patch work should be done before lowering unit.
9. Slide beams in close to the column. Lower the assembly and rest the clamp ears on the beams. Remove the sling.



## 1. INSTALLATION

---

10. After the column has been lowered and is resting on the setting beams, pour about half a cup of SAE 10 oil into the oil tubing. Apply joint compound to the leading threads of the lineshaft bearing. Oil bore lightly, slide over the shaft and thread into the oil tubing for half of its length. It should not be necessary to exert any side pressure on the shaft to start the bearing. The need for such pressure indicates misalignment, a bent shaft, or a bent oil tube in this or the preceding sections and must be corrected before proceeding.
11.
  - a. *If the column is threaded* and the setting is deep enough to require a rubber centering spider, slip the spider over the oil tubing and force into the column pipe about an inch or two below the top end. Spacing of the spiders is generally 20 feet from the bowl and from the head with 40 feet between each spider.
  - b. *If the column is flanged*, clean the registers in the flanges and insert the aligning ring. Slide the rubber centering spider over the oil tubing and into the column.
12. Clean all lineshaft threads and faces thoroughly. Screw the coupling on half of its length. Cover the coupling with a rag to prevent foreign matter from entering.
13. If there is more than one section of column, repeat Section D, steps 1 through 12, for each additional section until all of the column is assembled. Note that the top end of the top piece of oil tubing, the stretch tube, is chamfered and filed smooth on the O.D. and has extra long threads for the tension assembly.

### E. PUMP HEAD

1. Wipe a thin layer of joint compound on the top column threads, or, if connection is flanged, on the top flange face. Remove the packing gland assembly from the discharge head or motor stand. Clean all machined faces of the discharge head/motor stand thoroughly. Attach a sling to the discharge head/motor stand, hoist and center over the column. Lower the discharge head/motor stand being careful not to damage the top section of shafting known as the head shaft, or, the stretch tube (if applicable).
2.
  - a. Align the holes of the discharge head/motor stand with the holes of the column pipe flange, then lower until head is resting squarely on flange. Install bolts and tighten.
  - b. Set the discharge head on the top section of threaded column pipe. Screw the discharge head onto the column Pipe.
3. If there is an underground outlet, place the head as close as possible to the final position in relation to the outlet.
4.
  - a. If an adjustable top flange or threaded head is used, the head can be readily turned to place it in alignment to the underground outlet. In addition, the head should be turned as needed to attain the proper shaft projection and the correct distance from the outlet center line to the bottom of the head. Back the packing ring off to allow ample working room, fill the chamfer on the lower end of the flange with lampwick packing that has been precoated with joint compound. Use a generous amount of the packing and wind the packing around in such a manner that it is screwed into place. Screw the packing ring against the flange or bottom of the head and tighten.
  - b. If the adjustable flange is being used in conjunction with oil tubing, the top of the tubing should be approximately 1-1/4 inches below the tension box mounting face of the head after the flange is adjusted.
5. Hoist head slightly. Remove the clamp from the top piece of column. Remove setting beams and clean surface of the foundation itself. If there is an auxiliary line to the bowl bearing or thermo-well, that portion immediately below and attaching to the head should now be installed. Properly place discharge outlet and align mounting holes with anchor bolts and lower until head is resting squarely on the foundation.
6.
  - a. If head is resting on foundation plate, align mounting holes of the head with tapped holes in the foundation plate. Install and tighten cap screws.
  - b. Mix a sufficient quantity of rather dry non-shrink grout. Force as much grout under the foundation plate as possible. If grout holes are provided, grout can be pressure-fed through the grout holes until all cavities are filled.
  - c. As the head is resting on the foundation, drive wedges under head until proper elevation is achieved and continue working with wedges until head is within .005 inches of the Total Indicated Run-out with respect to top or head shaft. Install and tighten hex nuts to anchor bolts. Grout under the outer perimeter of the head and cover the wedges with the grout.

## 1. INSTALLATION

- d. If a motor stand is used, as in an underground discharge application, it should first be determined that the outlet in the column aligns with the discharge piping so that no strain will be placed on the pump. *Do not make this correction at this time, however.* After checking the pipe alignment follow Step 4a for leveling and grouting.
- e. Step 6d should be followed if there is a suction connection to the header. It is recommended that a flexible joint of some description be used between the suction flange and header to compensate for any slight misalignment. If no flexible joint is used, the header flange must be perfectly aligned so that no misalignment is transferred to the pump.

## F. PACKING GLAND OR MECHANICAL SEAL

### 1. Packing Gland Open Line Shaft

- a. Remove the packing gland, packing rings and lantern ring from the gland assembly. Clean the packing box thoroughly and apply a neoprene o-ring to the receiving hole in the discharge head.
- b. Slide the packing box over the head shaft. Properly adjust mounting holes so that the grease ports of the Packing gland are directed toward the access windows of the discharge head or motor stand. Seat the packing gland against the discharge head/motor stand then install and tighten cap screws. It should not be necessary to exert any side pressure on the shaft in order to seat the packing box properly.
- c. Reseat packing. See Section 7.4 for details.
- d. Slip rubber slinger over shaft and position just above the packing gland.

### 2. Mechanical Seal Open Line Shaft

- a. Inspect the seal assembly to be sure O-rings are included on the seal housing cover and the shaft sleeve. On the lock ring, be sure the lower set screws are tight and upper set screws are loose. See Illustration 1.4.
- b. Prior to installing the shaft sleeve o-ring lubricate with light grease, then slide complete assembly over head shaft. Seat and bolt down the assembly against the seal housing, taking care to be sure that the O-ring of the seal housing cover is in its groove.
- c. To set seal, first set impeller lateral, then tighten top set Of set screws of the lock ring. Remove paper spacers and keep for future use.

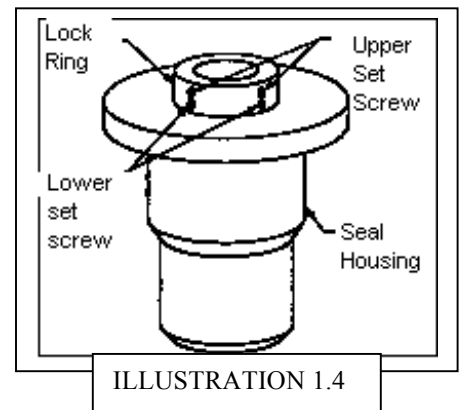

### 3. Oil Lube Enclosed Line Shaft

- a. If a motor stand is employed, go to Section F, step 3b. Screw the oil tube lock nut onto the extension tube.
- b. Place the gasket around the tube tension nut seat of the discharge head/motor stand. Screw the tube tension nut onto the extension tube until it seats against the gasket. Tighten the tube tension nut one-quarter turn for close coupled applications. Tighten the tube tension nut enough to take up 3/16" per every hundred feet in deep well application.
- c. If a motor stand is employed, go to Section F, step 3d. Insert a short piece of shafting or a board through the discharge opening of the discharge head. Place it against the tube lock nut and tighten the lock nut against the tube tension nut.
- d. Seat two rings of packing into the tube tension nut and around the extension tube. Screw on the packing follower and tighten securely against the packing rings. Position the dust cover on the tube tension nut and align the holes of the dust cover with the tapped holes in the discharge head/motor stand. Install and tighten cap screws.

## 1. INSTALLATION

---

### 4. Water Flushed Enclosed Line Shaft

- a. If a motor stand is employed, go to Section F, Step 3b. Screw the oil tube lock nut onto the extension tube.
- b. Place the gasket around the tube tension nut seat of the discharge head/motor stand. Screw the tube tension nut onto the extension tube until it seats against the gasket. Tighten the tube tension nut one-quarter turn for close coupled applications. Tighten the tube tension nut enough to take up 3/16" per every hundred feet in a deep well application.
- c. If a motor stand is employed, go to Section F, step 3d. Insert a short piece of shafting or a board through the discharge opening of the discharge head. Place it against the tube lock nut and tighten the lock nut against the tube tension nut.
- d. Seat two rings of packing into the tube tension nut and around the extension tube. Screw on the packing follower and tighten securely against the packing rings.
- e. Position the water flushed packing box on the tube tension nut and align the holes with the tapped holes on the discharge head/motor stand. Install and tighten cap screws.
- f. Reseat packing. See Section 7.4 for details. There will be three rings of packing and no lantern ring.
- g. Slip rubber slinger over shaft and position just above the packing gland.

## G. VERTICAL MOTORS

### 1. Hollow Shaft Motor

- a. Clean threads and face of head shaft projecting above packing gland thoroughly, then oil threads lightly. Thread coupling on shaft for half of its length. Stuff a rag into open end of the shaft coupling.
- b. Remove the top cover from the motor. Unbolt the coupling (clutch or drive block) from the motor and remove the coupling.
- c. Run a fine flat file over the motor mounting surface of the head to remove any nicks or burrs. Thoroughly clean face and register with solvent. Wipe a thin layer of light oil over the surface. This will help prevent rust and will also facilitate slight driver shifting during coupling alignment.
- d. Attach the erector sling to the motor lifting lugs. Hoist motor sufficiently to allow easy access to mounting Flange. Remove nicks and burrs on the mounting flange with a fine flat file and thoroughly clean with solvent.
- e. If there is sufficient head room to install the motor shaft after placing the motor on the head, prepare the shaft as described in Step g below, then lower the motor shaft through the motor with the keyway end up. Install the head nut and thread it on 4 or 5 threads, then allow the shaft to suspend inside the motor.
- f. Hoist motor sufficiently to clear the stand and swing it over until motor is resting on mounting ring. Properly place conduit box, align mounting holes and install, but do not tighten cap screws.
- g. Clean the head shaft thoroughly and dress the threads and keyway with a 3-cornered file, if necessary. Lift the motor shaft and carefully lower it through the quill or hollow shaft (end with keyway goes toward the top) and allow shaft to contact head coupling. Remove the rag in the coupling. Screw the motor shaft into the motor coupling on the head shaft and tighten.
- h. Make temporary electrical connection to motor, **bump** starter to determine correct rotation (counter clockwise as viewed from above). Install and tighten cap screws to the motor and discharge head/motor stand. *If power is not available, **DO NOT** make final drive shaft connections (Steps I, j, & k) until power is available and correct rotation is determined.*
- i. Place the gib key on the drive plate over the hollow shaft against the drive shaft. Turn the rotor observing the clearance between key and shaft, shift driver until the key touches all around. Tighten the cap screws.
- j. Slide clutch over drive shaft, seat against drive plate, install and tighten bolts.
- k. **IMPELLER ADJUSTMENTS:** Turn clutch until keyways in shaft and clutch align; install and seat gib key. Thread head nut onto shaft until it seats against top of the clutch. Hold to keep the clutch from turning and turn head nut until impellers clear the bottom by the amount shown in chart on page 16 for the bowl being used, allowing the rotor to turn freely. Continue to tighten head nut until impellers are elevated a sufficient distance to accommodate pump hydraulic thrust and associated shaft stretch (see 6. ENGINEERING section of this manual for details). Align holes in head nut with taps in clutch, install and tighten machine screws. Place top cover on driver and secure.

## 1. INSTALLATION

---

### 2. Solid Shaft Motor

- a. Clean the threads and face of head shaft, then oil threads lightly. Thread coupling on the shaft for half of its length. Stuff a rag into open end of the shaft coupling.
- b. Slide the pump hub of the adjustable motor coupling onto the head shaft and insert the key. Screw the adjuster nut onto the head shaft.
- c. Attach the erector sling to the motor lifting lugs. Hoist motor sufficiently to allow easy access to mounting Flange. Remove nicks and burrs on the mounting flange with a fine flat file and thoroughly clean with solvent.
- d. While the motor is suspended from the erector sling, slide the motor hub of the adjustable motor coupling onto the motor shaft. Insert the key into the keyway of the motor hub far enough up the motor shaft to expose the keeper key seat on the motor shaft. Seat the keeper key onto the motor shaft. Pull the motor hub down over the keeper key.
- e. Bolt the spacer to the motor hub, if applicable.
- f. Hoist motor sufficiently to clear the stand and lower it until the motor is resting on the discharge head. Properly place the conduit box, align mounting holes and install cap screws.
- g. **IMPELLER ADJUSTMENT:** Adjust the adjuster nut until the clearance between the spacer/adjuster nut and the motor hub is equal to the impeller adjustment as stated in the Hydraulic Thrust Technical Data Chart in Section 6. ENGINEERING. Add additional clearance to the above adjustments to accommodate pump hydraulic thrust and the associated shaft stretch (see the Shaft Elongation Chart in Section 6. ENGINEERING of this manual for details).
- h. Make temporary electrical connections to motor, **bump** starter to determine correct rotation (counter clockwise when viewed from above). *If power is not available, **DO NOT** make final drive shaft connections (Step i) until power is available and correct rotation is determined.*
- i. Align holes and taps of the motor hub, pump hub, adjuster nut, and spacer (if applicable). Install and tighten cap screws.

## H. MISCELLANEOUS ASSEMBLIES

### 1. LUBRICATOR

Install the oil pot on the discharge head. Install the necessary pipe fittings from the oil pot to the oil dripper (sight glass down) to the inlet on the tube tension nut. If there is a solenoid oiler, install it between oil pot and oil dripper.

### 2. DISCHARGE PIPING

- a. Above and below floor piping should be installed in such a manner as to eliminate the possibility of the discharge head being strained. Gate valves, check valves, and other piping items must not depend upon the pump head for support.
- b. If a flexible joint, such as a dresser coupling, is to be used, the tie bolts and lugs used to span the flexible joint should be of sufficient strength to resist the force created by the discharge pressure at the pump head. None of this force should be imposed on the head or the foundation bolts. The tension should be taken carefully on these tie bolts so that any amount of forward movement induced to the head will be counteracted during operation so that alignment is maintained *throughout the operation*.

## 1. INSTALLATION

---

### 3. AIR RELEASE VALVE

Install the air release valve on the pump head or just beyond on the discharge piping. It is suggested that if a throttling valve is not furnished, a throttling device be used to restrict the discharge of air to insure that a cushion of air is available in the discharge head. Placement of the throttling device should be such that the air release valve is between the discharge head and throttling valve. *Note: Exhausting the air from a head too quickly often causes breakage.*

### 4. GAUGES AND MISCELLANEOUS PIPE CONNECTIONS

- a. Connect the pressure gauge to the tap in the discharge and, if required, in the suction flange. Position dial face to facilitate reading.
- b. Make drain pipe connections. Route piping so that it will not interfere with normal maintenance procedures.
- c. If packing gland bypass line is to be installed use the following chart to determine correct port for connection. The ports on the housing are marked "U" and "L" as referred to in chart.

Pressure	"L" Port	"U" Port
0-100PSI	Grease	Grease
100-300PSI	Grease	Bypass
300-450PSI	Bypass	Grease

### 5. ELECTRICAL CONNECTIONS

- a. All connections to the motor such as main leads, space heater leads, winding protection leads, etc., should be made in accordance with prevailing specifications.
- b. Motor wiring can be identified by the following designations:
  - H – Space Heaters
  - P – Thermostats
  - T – main leads (Connect per nameplate and voltage required) on motor.

## **2. STORAGE**

---

### **2-1. CONSIDERATIONS**

When a pump is made for use in a sump or a can, it is usually a short coupled or close coupled pump assembly. A short or close coupled pump is simply a short pump assembly. Short coupled pump assemblies are usually shipped assembled but with the driver separate. Storage for such a pump is an easy matter with little common sense. See Section 2-3 below.

Pumps used for well applications on the other hand, tend to be deep setting pumps. These are shipped unassembled. The unassembled pieces are generally the driver, the discharge or motor stand, column pipe, tube and shaft assemblies, and the bowl assembly. Again, common sense is the best tool for determining storage techniques. The following is a general listing.

### **2-2 GENERAL HINTS**

As stated in Section 1-1 INSTALLATION of this manual, it is a very good idea to make sure all of the necessary items ordered are received without damage.

- A. After uncrating/unpackaging and checking that all items were received in good order, recrate and package all items in the same manner that they were received. Clearly label each package as to the contents and use in the assembly.
- B. If more than one size and/or model of pump is ordered, take special care not to confuse like items, such as valves, Gauge, bolts and hardware, or spare parts, for the two or more pumps.
- C. Group parts according to their stage of assembly. Example: bowls first, column and shafting second, discharge third, and so on. This will save searching for the proper parts and hardware at any given point during assembly.

### **2-3 SHORT COUPLED PUMPS**

- A. Cover suction and discharge ports to prevent entrance of any foreign materials.
- B. Cover all other miscellaneous holes, i.e. pressure relief, prelube and pressure gauge holes, etc.
- C. Avoid exposure to weather and elements: either store indoors or cover with a tarp.
- D. Use a support framework so that no side pressure is exerted on the pump when placed in storage.

### **2-4 MISCELLANEOUS ITEMS**

The best storage for most parts will cover any openings and keep items from exposure to adverse conditions. Provide level support for all tubes and shafts so the parts will not fall or be knocked over. Protect any threads from damage.

### 3. BOWL DISASSEMBLY & ASSEMBLY

These things are listed merely as guidelines to proper storage. Storing any item will depend on the application, materials of construction, and the duration of the storage.

#### 3-1 BOWL DISASSEMBLY

1. Remove the bowl assembly from the column assembly.
2. Remove the bell suction from the bowl assembly
3. Remove the grease plug from the suction bowl.
4. Remove the cap screws connecting the discharge bowl to the top bowl and slide the discharge bowl off of the pump shaft. **DO NOT** let the weight of the bowls rest on the bowl shaft while removing.
5. Remove the cap screws connecting the top bowl to the suction bowl if single staged or the intermediate bowl if multiple staged. Slide the top bowl from the bowl shaft.
6. Slide the female end of a collet knocker (see illustration 3.2) toward the impeller collet. Slide the collet back and forth on the bowl shaft, knocking the impeller with enough force to jar the impeller loose from the collet. Remove the collet knocker.
7. Use a screwdriver to spread the collet. Remove the collet and the impeller from the bowl shaft.
8. Repeat Steps 6 through 8 until all impellers are removed.
9. Pull the bowl shaft from the suction bowl.
10. Loosen the set-screw on the sand collar and slide off of the bowl shaft.

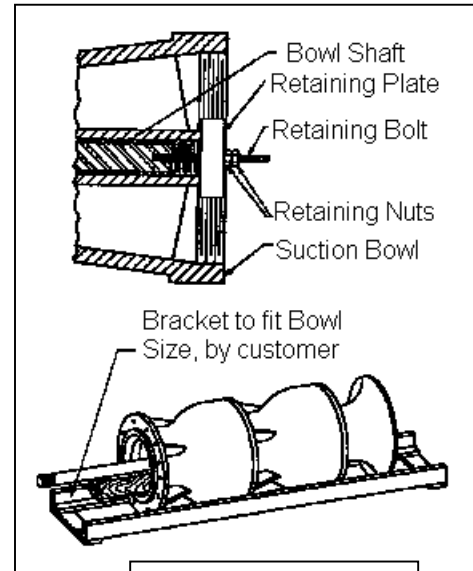

ILLUSTRATION 3.1

#### 3-2 BOWL ASSEMBLY

Before assembly, check the clearances of the bowl bearings and the impeller skirts. Check the bowl shaft for excessive wear.

1. Slide the bowl shaft into the suction bowl. Align the end of the shaft with the bottom of the bowl bearing.
2. Slide the sand collar on the bowl shaft and seat it over the bowl bearing. Temporarily tighten the set-screw.
3. The shaft stick-up must be set at this time. Slide the discharge bowl over the bowl shaft leaving enough space for the top bowl and the intermediate bowl(s) where applicable. Slide the bowl shaft in or out to allow for the proper stick-up. See Illustration 3.3. The stick-up is the distance from the top end of the bowl shaft to where the column pipe butts up to the bowl assembly. Attach a retainer plate as shown in Illustration 3.1. Tighten the sand collar setscrew.
4. Insert the retaining bolt through the suction bowl and tighten the locknut (finger tight).
5. Slide the discharge bowl off of the bowl shaft. Be careful not to damage the bowl shaft threads.

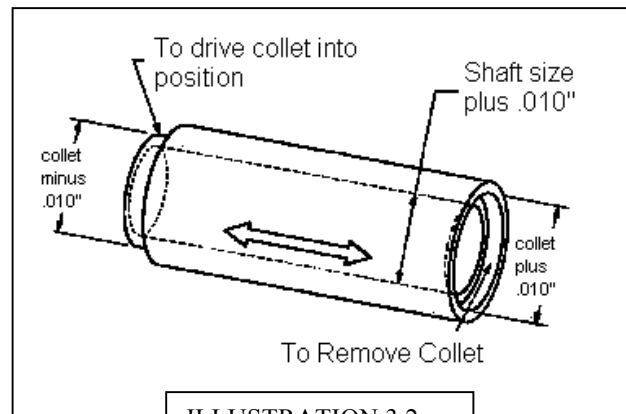

ILLUSTRATION 3.2

### 3. BOWL DISASSEMBLY & ASSEMBLY

6. Slide the impeller and the collet on the pump shaft and follow with the collet knocker (male side toward the impeller). Hold the impeller all the way to the bottom of the bowl with one hand and slide the collet into the impeller with the collet knocker. Drive the collet with the knocker until collet adequately holds impeller on shaft. Remove the collet knocker. See illustration 3.4.
7. Slide the intermediate bowl housing onto the pump shaft. Use caution to avoid putting the bowl weight on the bowl shaft. Bolt the intermediate bowl to the suction bowl with capscrews.
8. Continue Steps 6 to 7 until the assembly is complete.
9. Remove retainer bolt from the bowl shaft. Check the bowl shaft for rotation and lateral movement. Lateral should be as stated on page 16.
10. Fill the bearing cavity in the suction bowl with a non-soluble grease and insert the pipe plug in the bottom of the suction bowl.

BOWL BEARING DIAMETER CLEARANCE	
Shaft Diameter	Clearance
1.000	.007-.010
1.187	.0075-.0105
1.500	.009-.012
1.687	.0095-.013
1.937	.0105-.014
2.187	.0115-.015
2.687	.0125-.0165

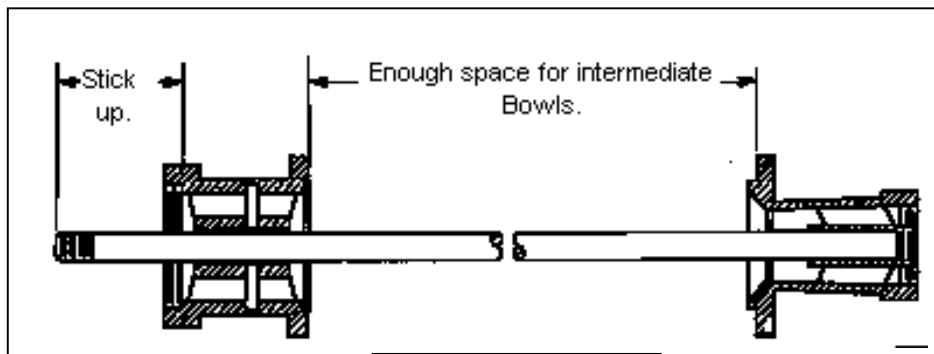

ILLUSTRATION 3.3

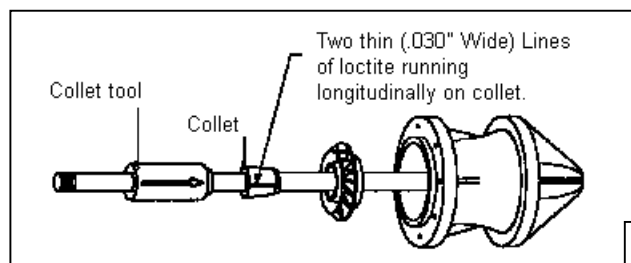

ILLUSTRATION 3.4



## 4. OPERATION

---

### 4-1. PRIOR TO START-UP

1. **WARNING: If unit is equipped with VFD (variable frequency drive) consult the factory for minimum and Critical pump speeds before start-up.**
2. Perform initial servicing on the driver as recommended by the driver manufacturer. Also perform initial servicing on all auxiliary assemblies if required.
3. Recheck all fasteners and fittings for tightness.
4. If the air release is manual or if air vent is automatic but equipped with a valve, make certain the valve is opened *partially* but not all of the way.
5. If there is a control valve on the discharge side of the pump, make certain it is partially open so that the pump will not be damaged if normal back pressure is not available until the long line, etc. is filled.
6. If unit is oil lubricated, fill lubricator with a good grade SAE 10 viscosity rating, low cold pour point mineral oil. Manually open needle valve and allow about a cup of oil to drain into tubing. Refill lubricator.
7. If pump is equipped with grease line to suction bowl bearing **DO NOT add grease on initial start-up. See preventative chart on page 20 for schedule.**
8. If unit is open lineshaft and equipped with pre-lubrication, turn on the pre-lubrication system and allow it to flow for 2 to 3 minutes.
9. If unit is force water lubricated, turn on and regulate flow from 10 to 15 PSI above normal discharge pressure. Lubrication should continue during entire pump operation time. If the tail bearing is also lubricated by outside water, pressure need only be 5 to 10 PSI.
10. **Bump** starter to insure that the unit has correct rotation.

### 4-2 INITIAL START-UP

1. Energize starter. After pump has come up to the rated speed and all air has been exhausted, regulate control valve to achieve desired pressure.
2. If the air release is manual, close it off after air is exhausted. If air release is automatic, determine if the air was Exhausted too quickly (which causes the pump to jerk violently when the valve is closed) or too slowly and regulate manual valve or throttling device to correct this.
3. If oil lubricated, regulate lubricator as shown in the following table.

SHAFT SIZE	PER 100 FEET OF COLUMN		TOTAL COLUMN LENGTH
	FIRST 2 WEEKS	AFTER 2 WEEKS	
$\frac{3}{4}$ TO 2-3/16	5 TO 6 DROPS	3 DROPS	ALL
ABOVE 2-3/16	10 TO 12 DROPS	6 DROPS	20 FEET

4. Check all joints for leakage and correct if evident.
5. Make certain the driver is operating satisfactorily as to temperature, bearing temperature , etc., as prescribed by the driver manufacturer.
6. Check for excessive vibration. If this is evident, shut down unit immediately and begin checking for the cause.
7. Adjust the packing gland (see Section 7-4.8 and 7-4.9) to allow some leakage past the packing.

### 4-3 ROUTINE/NORMAL

1. Start the pump in accordance with the starting equipment used.
2. Driver lubricants should be checked following the instructions in the Motor O & M manual attached.
3. The packing gland should be checked for proper leakage.

### 4-4 SHUTDOWN/EMERGENCY

1. Shutdown in accordance with the starting equipment used. Refer to Section 8 Trouble Shooting for further instructions.

## 5. FIELD TESTS

---

When a field test of the pump's performance is required, make the following readings: Volume, Total Head and Horsepower Measurements, Rotating Speed and liquid Temperature. Compare the results of the field test with performance curve for your pump.

All volume, total head and efficiency guarantees are based on a shop test when handling clear, cold, fresh water at a temperature not exceeding 85 Degrees F. and under certain specified suction conditions.

- (1) *Volume (Capacity) Measurement*- Measure the rate of flow from the pump discharge in gallons per minute. The volume measurement may be made using any one of the following pieces of equipment: A calibrated Venturi meter, a thin-plate calibrated orifice, a calibrated pilot tube, or an accurately measured reservoir.
- (2) *Total Head Measurement*- The total pumping head consists of: distance from the water level in the sump (when pumping) to the center of the discharge pressure gauge, plus the discharge gauge reading, the friction loss through the column and head, and the velocity head at the discharge.

*NOTE: Convert pressure gauge reading to feet of liquid by multiplying the reading times 2.31 times the Specific Gravity of Liquid.*

- (3) *Horsepower Measurement*- Measure horsepower consumption of the pump by a direct reading of a wattmeter and applying the reading to the following formula.

### Horsepower Formula:

$$\text{Bhp} = (\text{KW Input} \times \text{Eff}) * 0.746$$

Where: Bhp = brake horsepower delivered  
KW Input = real input power (KW)  
Eff = motor efficiency  
Eff = pump efficiency  
Sg = specific gravity of liquid

The motor efficiency can be determined from dynamometer tests.

### Pump Efficiency Formula:

$$\text{Pump Eff.} = (\text{TDH} \times \text{GPM} \times \text{Sg}) / (3960 \times \text{BHP})$$

Where: TDH = total dynamic head  
GPM = gallons per minute

## 5-2 DOWNTHRUST

Downthrust is the total thrust load expressed in pounds carried by the thrust bearings in the motor, gear drive or pump head. It is the sum of the weight of the rotating elements and the hydraulic downthrust of the bowl unit.

The shaft length is the sum of the setting (column length), the length of the discharge head and the driver (from dimension sheet) and the length of the bowl assembly (from the pump curve).

### Example:

Given a 6 stage 10RC bowl assembly, 75 HP, 1770 RPM motor, HF6 discharge head, 200' setting, 1-1/2" shaft, 6" column, and 312' total dynamic head.

For K factors, lateral, and shaft weights, see page 16.

For impeller weight, see performance curve for the unit.

- (1) 200' (setting) + 6.5' (bowl shaft) + 5' (head shaft) = 211.5' feet of shafting
  - (2) 211.5 x 6.01 lbs. (shaft weight per foot) = 1271 lbs. of shaft
  - (3) 312' TDH x 4.7 (K factor) = 1466 lbs. hydraulic thrust
  - (4) 6 (number of impellers) x 11 lbs. (weight of one impeller) = 66 lbs.
- Add (2), (3), and (4) and get 2803 lbs. of total thrust load

The motor data sheet shows a 75 HP motor at 1800 RPM to have a normal thrust capability of 4800 lbs., so no additional thrust load capacity is required. *Note: Coupling weight may be added for deep setting pumps.*

---

## 5. FIELD TESTS

---

### 5-3 SHAFT STRETCH

The hydraulic thrust when the pump is operating imposes an axial tensile load on the shaft, which causes the shaft and column pipe to stretch. It is necessary, therefore, to determine the magnitude of the net elongation and whether or not the elongation exceeds the clearance provided in the pump bowls. If there is insufficient clearance, the impeller skirts will rub on the bowl seal rings, resulting in excessive wear and power consumption.

From the example above, we have 1466 lbs. of hydraulic thrust. From the shaft elongation chart (page 17), it is found by interpolation that the elongation for 1-1/2" shaft at 1466 lbs. hydraulic thrust is .034" per 100' of shaft-

$$\text{Elongation for 200' of shaft} = (200/100) \times .034'' = .068''$$

Column elongation is found by the same method using the column elongation chart (page 17) –

$$\text{Elongation for 200' of column} = (200/100) \times .006'' = .012''$$

Shaft elongation minus column elongation equals net elongation –

$$.068'' - .012'' = .056''$$

Check the chart on page 16 under *Bowl Data* to see if the standard lateral provided is adequate; if not, extra lateral may be machined if required.

**Customer:**

**Hydroflo Model:**

**Lateral:**

**K factor:**

**Impeller Type:**

**Impeller adjustment:**

**MINIMUM SUBMERGENCE:**

**Shaft Weights**

<b><u>Size</u></b>	<b><u>Weight (lbs per ft.)</u></b>
1"	1.50
1 3/16"	3.77
1 1/4"	4.17
1 7/16"	5.52
1 1/2"	6.01
1 11/16"	7.60
1 15/16"	10.02
2 3/16"	12.78
2 7/16"	15.87
2 11/16"	19.29

**6. ENGINEERING**

**SHAFT ELONGATION CHART**  
(inches per hundred feet of shafting)

HYDRAULIC THRUST	SHAFT DIAMETER (INCHES)								
	3/4	1	1-3/16	1-1/2	1-11/16	1-15/16	2-3/16	2-7/16	2-11/16
500	.047	.026	.018	.012	.009	.007			
600	.056	.032	.022	.014	.011	.008	.006		
800	.075	.042	.030	.019	.015	.011	.009		
1,000	.094	.053	.037	.024	.019	.014	.011	.009	
1,200	.112	.063	.045	.028	.022	.017	.013	.011	
1,400	.131	.074	.052	.033	.026	.020	.015	.012	.010
1,600	.150	.084	.060	.038	.030	.022	.018	.014	.012
1,800	.169	.095	.067	.042	.033	.025	.020	.016	.013
2,000	.187	.105	.075	.047	.037	.028	.022	.018	.015
2,400	.225	.127	.090	.056	.044	.034	.026	.021	.018
2,800	.262	.148	.105	.066	.052	.039	.030	.025	.020
3,200		.169	.119	.075	.059	.045	.035	.028	.023
3,600		.190	.135	.085	.067	.051	.040	.032	.026
4,000		.211	.150	.094	.074	.056	.044	.036	.029
4,400		.240	.164	.103	.081	.062	.048	.039	.032
4,800		.253	.179	.113	.089	.067	.053	.043	.035
5,200		.274	.194	.122	.096	.073	.057	.046	.038
5,600			.209	.131	.107	.079	.062	.050	.041
6,000			.224	.141	.111	.084	.066	.053	.044
6,500			.243	.153	.120	.091	.071	.058	.047
7,000			.260	.164	.129	.098	.077	.062	.051
7,500				.176	.139	.105	.082	.067	.055
8,000				.188	.148	.112	.088	.071	.058
9,000				.211	.167	.126	.098	.080	.066
10,000				.234	.185	.140	.110	.089	.073
12,000				.281	.222	.168	.132	.106	.088
14,000					.259	.196	.154	.124	.102
16,000					.296	.224	.176	.142	.117
18,000						.252	.198	.160	.131
20,000						.280	.220	.176	.146
22,000							.242	.195	.160
24,000							.264	.213	.175
26,000							.286	.230	.190
28,000								.248	.204
30,000								.266	.219

**6. ENGINEERING**

**COLUMN ELONGATION CHART**  
(inches per hundred feet of shafting)

HYDRAULIC THRUST	NOMINAL COLUMN DIAMETER (inches)								
	3	4	5	6	8	10	12	14	16
500	.007	.005	.004	.003					
600	.008	.006	.005	.004					
800	.011	.008	.006	.005					
1,000	.013	.010	.008	.006	.004				
1,200	.016	.012	.009	.007	.005				
1,400	.019	.014	.011	.008	.006				
1,600	.021	.016	.012	.009	.007	.005			
1,800	.024	.018	.014	.011	.008	.006			
2,000	.027	.020	.015	.012	.009	.007			
2,400	.032	.023	.019	.014	.010	.008	.006		
2,800	.037	.027	.022	.016	.012	.010	.007		
3,200	.043	.031	.025	.019	.014	.011	.008		
3,600	.048	.035	.028	.021	.016	.012	.009	.008	
4,000		.039	.031	.023	.017	.014	.010	.008	
4,400		.043	.034	.026	.019	.015	.011	.009	
4,800		.047	.037	.028	.021	.016	.013	.010	.009
5,200		.051	.040	.030	.023	.018	.014	.011	.010
5,600		.055	.043	.033	.024	.019	.015	.012	.011
6,000			.046	.035	.026	.020	.016	.013	.011
6,500			.050	.038	.028	.022	.017	.014	.012
7,000			.054	.041	.030	.024	.018	.015	.013
7,500			.058	.044	.033	.025	.020	.016	.014
8,000			.062	.047	.035	.027	.021	.017	.015
9,000				.053	.039	.030	.023	.029	.017
10,000				.059	.043	.034	.026	.021	.019
12,000				.070	.052	.041	.031	.025	.023
14,000				.082	.061	.048	.036	.029	.026
16,000				.094	.070	.054	.042	.034	.030
18,000					.078	.061	.047	.038	.034
20,000					.087	.068	.052	.042	.037
22,000					.096	.075	.057	.046	.041
24,000					.104	.082	.063	.050	.045
26,000					.113	.088	.068	.055	.049
28,000						.095	.073	.059	.052
30,000						.102	.078	.063	.056

## 7. MAINTENANCE

---

### 7-1 GENERAL

1. For normal operation and maintenance of driver, follow the instructions of the driver manufacturer.
2. If the pump is oil lubricated, check the oil level in the lubricator and refill on a regular schedule.
3. If the unit requires pre-lubrication, make certain this process is started with ample time prior to pump start-up to insure that all bearings are properly wetted.
4. Apply grease to the packing box assembly at the rate of ¼ to ½ oz. for each 24 hours of operation. See Section 7-5 PREVENTATIVE MAINTENANCE.
5. Bowl bearings are self lubricated by the liquid pumped. Lower suction bowl bearing is packed at the factory with no maintenance required in the field.
6. The packing box should seldom require adjustment but in the event that the leakage becomes excessive, see Section 7-4 for details. Remember that over tightening wears out the packing rings prematurely and causes scoring and damage to the shaft. Always adjust the gland with the unit running.

### 7-2 BEARING REPLACEMENT

1. Alloy bearings, such as bronze, can be readily pressed in with an arbor or screw press. If this is not available, they can be driven in very carefully with a block of wood and a hammer. Make certain that bearing projections are maintained.
2. Graphite and composition bearings do not possess great tensile or compressive strength and cannot be driven in as alloy bearings can. They must be pressed in with a slow, continuous and even motion attained with an arbor or screw press with a mandrel to fit the bearing properly. The hub bore and the bearing should be lubricated with water to aid the pressing operation. DO NOT LUBRICATE WITH OIL OR GREASE.

### 7-3 WEAR RING REPLACEMENT

1. Wear rings can be removed by cutting the cross section with a chisel and prying one end inward until it is loose in the bore. To install, make a mandrel to fit the wear rings and press in with an arbor or screw press. In an emergency, the wear rings can be installed by gently and evenly tapping around the top edge with a wood block and a hammer or a rubber mallet.
2. If impeller skirts are equipped with wear rings, cut the wear ring cross section with a chisel and force off. Heat on the ring will assist in the removal and installation. To install, make a mandrel to fit the O.D. of the wear rings and press flush with the bottom of the impeller skirts. If necessary, gently and evenly tap around the top edge with a wood block and a hammer or with a rubber mallet.
3. If oil seals must be replaced, make certain they are always installed with their lips pointing down. They are used primarily to keep water out of the enclosing tube rather than to keep the oil in the tube.

### 7-4 PACKING REPLACEMENT

When the packing has been compressed to the point that the gland is about to contact the upper face of the packing box, remove the gland, add one extra packing ring and re-adjust. If this fails to reduce the leakage, remove all of the packing rings and repack with new rings.

These are the step by step procedures in repacking a packing box in the pump:

1. Clean out the old packing. This includes the packing below the lantern ring. Often the old packing below the Lantern ring is not replaced when repacking the gland as it should be. Flexible packing hooks are available for removing the packing.
2. Check the shaft for nicks and score marks; remove any that are present; then clean carefully. Clean up the bore of the box. Check the lantern ring to make sure the channels and holes are not plugged up.
2. If the replacement packing is in the form of a continuous coil or rope, it must be cut into rings before installing.

## 7. MAINTENANCE

After cutting on the mark, the first length of packing may be used as a template for cutting all the other rings. Begin by installing the first ring. It is recommended that grease or oil be smeared on at least the outer diameter of the ring.

4. With the aid of a split bushing, push the packing to the bottom of the box. The O.D. of this split bushing should be approximately .005 inch smaller than the bore of the packing box to prevent the formation of a lip on the packing that is being seated. Seat this bottom ring hard because it must seal on the face of the packing box bearing as well as against the shaft and the bore. See Illustration 7.1.
5. Repeat this operation with each ring making sure to stagger the gaps formed by the ends of the ring at 90 degree intervals. See Illustration 7.2.
6. If a lantern ring is used, be sure it is properly positioned so it is centered with the drilling in the packing box. See Illustration 7.3.
7. Position the packing gland. Tighten it down evenly. The packing gland must not be cocked within the packing box. An unsquare packing gland causes uneven compression of the packing rings and more importantly, damage to the shaft. Good practice is to allow at least  $\frac{1}{4}$  inch from the top of the top packing ring to the top face of the packing box. This helps center the gland and minimizes cocking. See Illustration 7.4.
8. Permit sufficient leakage to keep the packing box running cool. Adequate leakage at this time is a necessity. Check the temperature of the leakage as well as the pump housing. If the pump runs hot and the leakage begins to choke off, stop the pump and let it cool down. Steps 4-8 must be repeated when the packing is adjusted.
9. Allow the pump to run 15 minutes and if leakage rate is more than desirable, tighten the gland nuts  $\frac{1}{8}$  of a turn. This packing adjustment is made with the pump running. Before making another adjustment, allow the packing to equalize against the increased pressure and the leakage to gradually decrease to a steady rate. ***PUMP PACKING MUST ALWAYS LEAK SLIGHTLY.***

Note:

1. Chances are the packing will run a little warmer for the first few days until the packing rings have burnished in. Often the leakage rate will reduce by itself at this time.
2. Remember that metallic and plastic packings are good for temperatures of at least 450 degrees F.. So, even if the leakage is warmer than the fluid being pumped, it doesn't mean that the packing is being damaged.

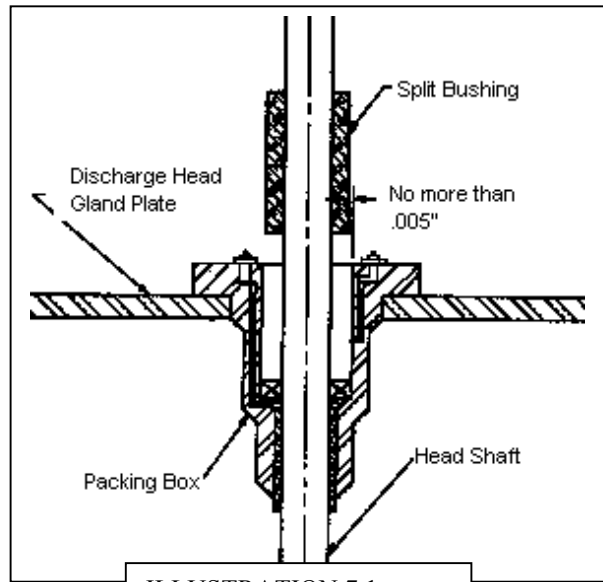

ILLUSTRATION 7.1

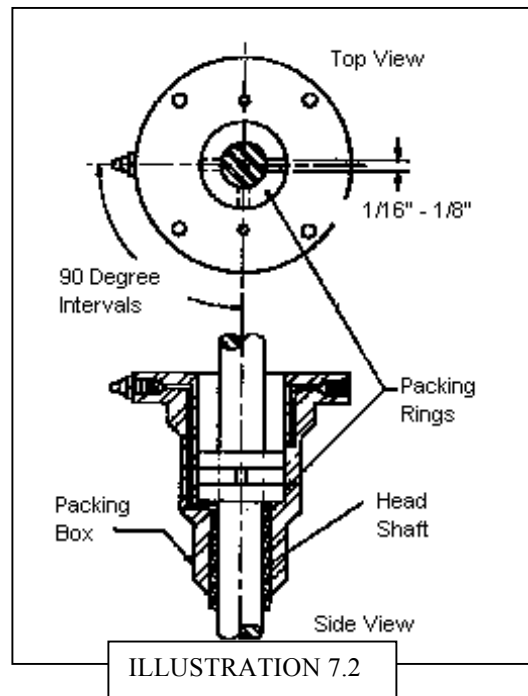

ILLUSTRATION 7.2



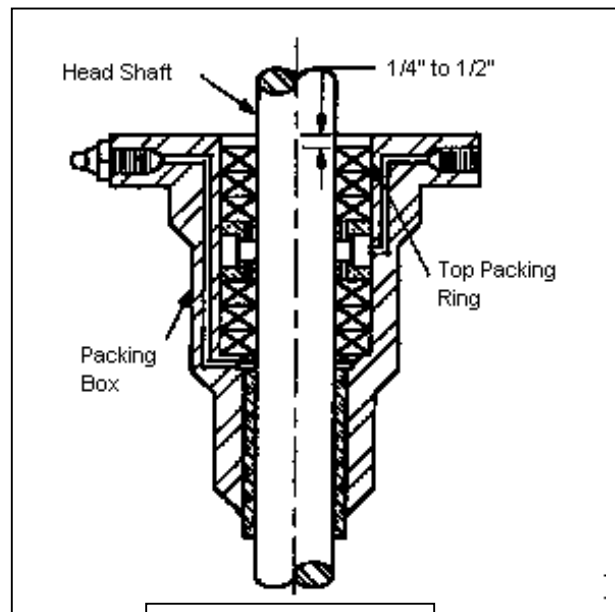
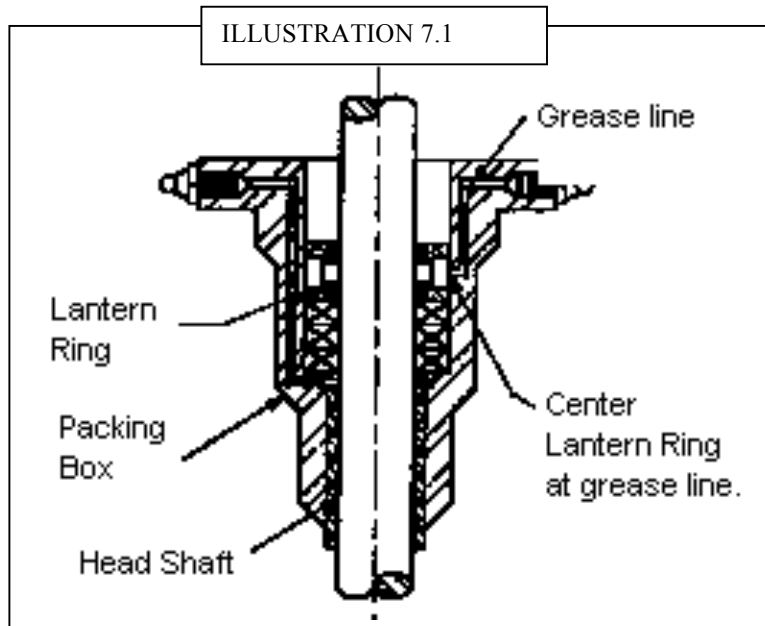

ILLUSTRATION 7.4

## 7. MAINTENANCE

### 7-5 PREVENTIVE MAINTENANCE

Proper preventive maintenance consists of maintaining records of operation hours, operating data, gauge readings, and service performed on the pump. Using this information in conjunction with the suggested preventive maintenance schedule below will reduce downtime and prevent costly breakdowns.

**PREVENTIVE MAINTENANCE INTERNAL INSPECTION CHART**

FREQUENCY OF INSPECTION	COMPONENT	INSPECTION AND MAINTENANCE
Weekly	Driver Motor	Clean oil, dust, water and chemicals from the exterior of motor. Make sure motor air intake and outlets (fan cooled motor) are unobstructed.
Monthly	Driver Motor	Check motor bearing temperature with temperature indicator (not your hand). If bearings are running hot, consult motor manufacturer's instructions.
	Packing Gland	Grease with modest amount of packing lubricant.
Every 3 months (2000 operating hours).	Packing Gland	Inspect packing and replace if necessary.
	Headshaft	Check the shaft. Scoring accelerates wear on packing. Repair or replace shaft if scoring is evident.
Semi-annually (4000 operating hours).	Pump	Check operating vibration of the pump and compare to vibration check taken during initial inspection. If vibration has changed, shut down pump and inspect bowl assembly for damage or clogging.
	Pump foundation	Check foundation for setting. It may cause misalignment of pump and strain on discharge and suction piping. Correct for any change in foundation.
	Pump Performance	Check discharge and suction pressure readings against initial field test and correct by adjusting impellers if performance has dropped in excess of 10%.
Annually	Packing Gland	Remove by-pass piping from packing gland and check for scaling and deposits that restrict flow. Replace piping.
	Pump Efficiency	Measure total dynamic head and flow. Take power readings. Compare with initial record of pump efficiency. If efficiency has decreased more than 5%, re-adjust impellers. If performance does not improve, replace impeller or wear ring as required.
	Suction Bowl Bearing	Repack suction bell bearing if pump is short coupled or booster can type and supplied with grease line to suction bearing. <b>Caution:</b> use <i>non-soluble grease</i> . <b>DO NOT</b> overgrease, which can push shafting up and alter impeller setting.

## 7. TROUBLE SHOOTING

---

### 8-1 TROUBLE SHOOTING

#### **INSUFFICIENT PRESSURE**

1. Speed too slow (check voltage).
2. Impeller trimmed incorrectly.
3. Impeller loose.
4. Impeller plugged.
5. Wear rings worn.
6. Entrained air in pump.
7. Leaking joints or bowl casings.
8. Wrong rotation.
9. Incorrect impeller adjustment.

#### **NO LIQUID DELIVERED**

1. Pump suction broken (water level below inlet)
2. Suction valve closed.
3. Impeller plugged.
4. Strainer clogged.
5. Wrong rotation.
6. Shaft broken or unscrewed.
7. Impeller loose.
8. Barrel or discharge not vented.
9. Driver inoperative.

#### **VIBRATION**

1. Motor imbalance (electrical).
2. Motor bearing is not properly seated or is worn.
3. Motor drive coupling out of balance or alignment.
4. Misalignment of pump, casing, discharge head, column, and/or bowls.
5. Discharge head misaligned by improper mounting or pipe strain.
6. Bent shafting.
7. Worn pump bearings.
8. Clogged impeller or foreign material in pump.
9. Improper impeller adjustment.
10. Vortex problems in sump.
11. Resonance (system frequency at or near pump speed).
12. Cavitation.
13. Impeller out of balance.

#### **INSUFFICIENT CAPACITY**

1. Speed too slow.
2. Impeller trimmed incorrectly.
3. Impeller loose.
4. Impeller or bowl partially plugged.
5. Leaking joints.
6. Strainer or suction pipe clogged.
7. Suction valve throttled.
8. Low water level.
9. Wrong rotation.
10. Insufficient submergence.
11. Insufficient N.P.S.H.
12. Incorrect impeller adjustment.
13. Worn pump.
14. Pressure higher than design.

#### **USING TOO MUCH POWER**

1. Speed too high.
2. Improper impeller adjustment.
3. Improper impeller trim.
4. Pump out of alignment.
5. Coupling out of alignment.
6. Pumping foreign material.
7. Lubrication oil too heavy.
8. Bent shaft.
9. Tight bearing or packing.
10. Specific gravity or viscosity of fluid higher than design.
11. Worn pump.
12. Damaged pump.
13. Partial freezing of pump liquid.

#### **ABNORMAL NOISE**

1. Motor noise.
2. Pump bearing running dry.
3. Broken column bearing retainers.
4. Broken shaft or oil tubing.
5. Impeller dragging on bowl case.
6. Cavitation, due to insufficient N.P.S.H.A. and/or submergence.
7. Foreign material in pump.
8. Excessive fluid velocity in pipe system.

## 8. TROUBLE SHOOTING

### 8-2 IMPELLERS

TROUBLE SOURCE	PROBABLE CAUSE	REMEDY
Wear on exit vanes and shrouds.	Abrasive action.	Replace impeller if excessive. Consider coating or upgrading material.
Pitting on entrance vanes of impellers.	Cavitation.	Correct condition or upgrade material to extend life.
Pitting on impellers and bowl castings.	Corrosion/Erosion	Investigate cost of different materials vs. frequency of replacements.
Wear on impeller skirts and/or bowl seal ring area.	<ol style="list-style-type: none"> <li>1. Abrasive action or excess wear impeller skirts to function as bearing journal.</li> <li>2. Impellers set too high.</li> </ol>	<ol style="list-style-type: none"> <li>1. Install new bearings and wear rings. Upgrade material if abrasive action.</li> <li>2. Re-ring and adjust impellers correctly.</li> </ol>
Impeller loose on shaft (extremely rare occurrence).	<ol style="list-style-type: none"> <li>1. Repeated shock load by surge in suction or discharge line. (Can loosen first or last stage impellers.)</li> <li>2. Foreign material jamming impeller. (May break shaft or trim over loads before impeller becomes to loose.)</li> <li>3. Differential expansion due to temperature.</li> <li>4. Parts improperly machined and/or assembled.</li> <li>5. Torsion loading on submersible pumps.</li> </ol>	<ol style="list-style-type: none"> <li>1. Re-fit impellers. If collet mounted, consider changing to key mounting.</li> <li>2. Remove cause of jamming.</li> <li>3. If collet mounted, consider change to key mounted. Avoid sudden thermal shock.</li> <li>4. Correct parts if necessary and refit.</li> <li>5. Add keyway to collet mounting.</li> </ol>

### 8-3 BEARINGS

TROUBLE SOURCE	PROBABLE CAUSE	REMEDY
Bearing seized or galling on shaft.	Running dry without lubrication.	Check lubrication, look for plugged suction or evidence of flashing.
Bearing failure or bearing seized.	High temperature failure.	Check pump manufacturer for bearing temperature limits.
Excessive shaft wear under rubber.	Rubber bearings will swell in hydrocarbon, H.S., & high temperature.	Change bearing material.
Premature bearing wear.	Abrasive action.	Consider conversion to water flushing on all bearings, pressure grease or oil lubrication.
Uneven wear on bearings, uniform wear on shaft.	Pump's non-rotating parts misaligned.	Check mounting and discharge pipe connection, dirt between column joints. Correct misalignment, replace bearings and repair or replace shaft.
Uniform wear on bearings and shaft.	Abrasive action.	Replace parts, consider changing materials or means of lubrication.
Uniform wear on bearings, uneven wear on shaft.	<ol style="list-style-type: none"> <li>1. Shaft run-out caused by bent shafts, shafts not butted on couplings, dirt or grease between the shafts.</li> <li>2. Shafts ends not properly faced.</li> </ol>	<ol style="list-style-type: none"> <li>1. Straighten shaft or replace, clean and assemble correctly.</li> <li>2. Face parallel and concentric.</li> </ol>

## 8. TROUBLE SHOOTING

### 8-4 SHAFT AND COUPLING

TROUBLE SOURCE	PROBABLE CAUSE	REMEDY
Bent shaft	Mishandling in transit or assembly.	Check straightness. Correct to .005"/ft total run-out or replace.
Shaft coupling elongated, (neck down.)	<ol style="list-style-type: none"> <li>1. Motor is started while pump running in reverse.</li> <li>2. Corrosion</li> <li>3. Pipe wrench fatigue on reused couplings.</li> <li>4. Power being applied to shafts that are not butted in coupling.</li> </ol>	<ol style="list-style-type: none"> <li>1. Look for faulty check valve. Could also be momentary power failure or improper starting timers.</li> </ol>
Shaft coupling unscrewed	Pump started in reverse rotation.	Shafts may be bent, check shafts and Couplings. Correct rotation.
Broken shaft or coupling.	<ol style="list-style-type: none"> <li>1. Can be caused by same reasons listed for coupling elongation.</li> <li>2. Can also be caused by bearings seized due to lack of lubrication.</li> <li>3. Foreign material blocking impellers or galling wear rings.</li> <li>4. Metal fatigue due to vibrations.</li> <li>5. Improper impeller adjustment or continuous up-thrust conditions, causing impeller drag.</li> </ol>	<ol style="list-style-type: none"> <li>1. Same as above.</li> <li>2. Same as above for bearing seizure.</li> <li>3. Add strainers or screens.</li> <li>4. Check alignment of the pump components to eliminate vibration.</li> <li>5. See Engineer Section for correction</li> </ol>

### 8-5 BOWLS

TROUBLE SOURCE	PROBABLE CAUSE	REMEDY
Wear on bowl vanes.	Abrasive action	Coat bowls, upgrade material or rubber line.

### 8-6 PACKING BOX

TROUBLE SOURCE	PROBABLE CAUSE	REMEDY
Excessive leakage	<ol style="list-style-type: none"> <li>1. Improper packing.</li> <li>2. Incorrect type or defective packing.</li> <li>3. Worn shaft or sleeve.</li> </ol>	<ol style="list-style-type: none"> <li>1. Repack correctly.</li> <li>2. Repack with the correct grade for service.</li> <li>3. Remachine or replace scored parts.</li> </ol>
Packing box overheated.	<ol style="list-style-type: none"> <li>1. Improper packing procedure.</li> <li>2. Packing too tight.</li> <li>3. Insufficient lubrication.</li> <li>4. Incorrect type of packing.</li> </ol>	<ol style="list-style-type: none"> <li>1. Repack correctly.</li> <li>2. Repack with the correct grade for service.</li> <li>3. Remachine or replace scored parts.</li> </ol>
Packing wears prematurely.	<ol style="list-style-type: none"> <li>1. Improper packing.</li> <li>2. Insufficient lubrication.</li> <li>3. Shaft or sleeve scored.</li> <li>4. Incorrect type of packing.</li> </ol>	<ol style="list-style-type: none"> <li>1. Remove cause.</li> <li>2. Replace worn parts.</li> <li>3. Remachine or replace scored parts.</li> <li>4. Repack with correct grade for service.</li> <li>5. Remove source of abrasives.</li> </ol>

### 8-7 INNER COLUMN

TROUBLE SOURCE	PROBABLE CAUSE	REMEDY
Water in inner column.	<ol style="list-style-type: none"> <li>1. Bypass ports plugged.</li> <li>2. Badly worn bypass seal or bearings.</li> <li>3. Tubing joint leaking.</li> <li>4. Crack or hole in tubing.</li> </ol>	<ol style="list-style-type: none"> <li>1. Remove cause.</li> <li>2. Replace worn parts.</li> <li>3. Ensure tubing joint face is clean and is butted squarely.</li> <li>4. Replace section affected.</li> </ol>

## 9. ORDERING PARTS

---

### 9-1 Ordering Parts

To order parts, please identify the three digit catalog number by matching the parts needed with the drawings (if provided) in the manual (see chart below for examples). Drawings start after this page. If no drawings are included in the manual, please contact your Hydroflo representative for more information.

<b>Cataloge #</b>	<b>Part Name</b>
001	Head, Discharge
003	Shaft, Motor
101	Shaft, Line
201	Bowl, Discharge

We will also need the serial number of the pump, which should be on your invoice or the pump information tag. If you have any problems, please contact your Hydroflo representative for more information.





[WWW.HYDROFLOPUMPS.COM](http://WWW.HYDROFLOPUMPS.COM)

## HYDROFLO PUMPS USA, INC.

7118 LOBLOLLY PINE BLVD.  
**FAIRVIEW, TN** 37062  
PHONE: 615.799.9662  
FAX: 615.799.5654

13265 S.R. 17  
**CULVER, IN** 46511  
PHONE: 615.799.9662  
FAX: 615.799.5654

3510 WOOD RIVER ROAD  
**GRAND ISLAND, NE** 68803  
PHONE: 308.398.0920  
FAX: 308.398.0923

1886 DAVID BAILEY ROAD  
**BROWNFIELD, TX** 79316  
PHONE: 806.637.8961  
FAX: 806.637.8964

5437 S. NIKITA AVENUE  
**FRESNO, CA** 93725  
PHONE: 559.834.1945  
FAX: 559.834.9705

2498 KUHN RD  
**MARION, AR** 72364  
PHONE: 870.735.0400  
FAX: 870.733.0500