

# OPERATION AND PARTS MANUAL



## **Vibratory Walk-Behind Roller *Mikasa* Model MDR-9D (Hatz Diesel)**

© COPYRIGHT 2003, MULTIQUIP INC.

Revision #0 (12/17/03)



**MULTIQUIP INC.**

18910 WILMINGTON AVE.  
CARSON, CALIFORNIA 90746  
310-537-3700  
800-421-1244  
FAX: 310-537-3927

**E-mail:** [mq@multiquip.com](mailto:mq@multiquip.com) • **www:** [www.multiquip.com](http://www.multiquip.com)

Atlanta • Boise • Dallas • Houston • Newark  
Montreal, Canada • Manchester, UK  
Rio De Janeiro, Brazil • Guadalajara, Mexico

**PARTS DEPARTMENT:**

800-427-1244  
FAX: 800-672-7877  
**SERVICE DEPARTMENT/TECHNICAL ASSISTANCE:**  
800-478-1244  
FAX: 310-631-5032



# **WARNING**



## **CALIFORNIA — Proposition 65 Warning**

**Diesel engine exhaust and some of its constituents are known to the State of California to cause cancer, birth defects and other reproductive harm.**

## **HERE'S HOW TO GET HELP**

PLEASE HAVE THE MODEL AND SERIAL  
NUMBER *ON-HAND* WHEN CALLING

### ***MULTIQUIP'S MAIN PHONE NUMBERS***

800-421-1244      FAX: 310-537-3927  
310-537-3700

### ***PARTS DEPARTMENT***

800-427-1244      FAX: 800-672-7877  
310-537-3700      FAX: 310-637-3284

### ***MAYCO PARTS***

800-306-2926      FAX: 800-672-7877  
310-537-3700      FAX: 310-637-3284

### ***SERVICE DEPARTMENT***

800-478-1244      FAX: 310-537-4259  
310-537-3700

### ***MQ POWER SERVICE DEPARTMENT***

800-835-2551      FAX: 310-638-8046  
310-537-3700

### ***TECHNICAL ASSISTANCE***

800-478-1244      FAX: 310-631-5032

### ***WARRANTY DEPARTMENT***

800-421-1244, EXT. 279      FAX: 310-537-1173  
310-537-3700, EXT. 279

## MIKASA MDR-9D-VIBRATORY ROLLER

Proposition 65 Warning .....	2
Here's How To Get Help .....	3
Table Of Contents .....	4
Parts Ordering Procedures .....	5
Safety Message Alert Symbols .....	6-7
Rules for Safe Operation .....	8-9
Operation and Safety Decals .....	10
Specifications .....	11
Dimensions .....	12
General Information .....	14-15
Vibratory Roller Components .....	16
HATZ 1D81Z Engine Components .....	17
Inspection/Start-Up .....	18-21
Operation .....	22
Lifting/Transporting .....	23
Maintenance .....	24-29
Troubleshooting .....	30-31

## PARTS ILLUSTRATIONS

Explanation Of Code In Remarks Column .....	32
Suggested Spare Parts .....	33
Decal Placement .....	34-35
Body Assembly .....	36-37
Front Cover Assembly .....	38-39
Axle Assembly .....	40-43
Transmission Assembly .....	44-45
Hydraulic Oil Tank Assembly .....	46-47
Clutch Box Assembly .....	48-51
Vibrator Assembly .....	52-53
Upper Control Handle Assembly .....	54-57
Lower Control Handle Assembly .....	58-59
Battery Assembly .....	60-61

## Hatz 1D81Z Diesel Engine

Crankcase Assembly .....	62-63
Crankcase Assembly (External Parts) .....	64-65
Crankshaft Assembly .....	66-67
Camshaft Assembly .....	68-69
Piston/Rings Assembly .....	70-71
Cylinder Head Assembly .....	72-75
Flywheel Assembly .....	76-77
Oil Pump Assembly .....	78-79
Timing Cover Assembly .....	80-81
Fuel Device .....	82-83
Air Ducting Assembly .....	84-85
Breather Assembly .....	86-87
Fuel Tank Assembly .....	88-89
Fuel Pump Assembly .....	90-91
Air Filter Assembly .....	92-93
Exhaust Silencer .....	94-95
Starter/Alternator Assembly .....	96-97
Instrument Box Assembly .....	98-99
Lifting Magnet/Stop Device .....	100-101

Terms and Conditions Of Sale — Parts .....	102
--	-----

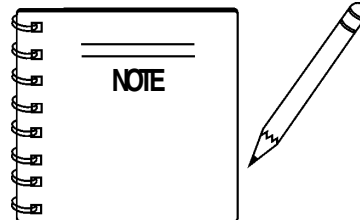

***Specification and part number are subject to change without notice.***

# PARTS ORDERING PROCEDURES

## When ordering parts, please supply the following information:

- Dealer account number
- Dealer name and address
- Shipping address (if different than billing address)
- Return fax number
- Applicable model number
- Quantity, part number and description of each part
- Specify preferred method of shipment:
  - ✓ FedEx or UPS Ground
  - ✓ FedEx or UPS Second Day or Third Day
  - ✓ FedEx or UPS Next Day
  - ✓ Federal Express Priority One
  - ✓ DHL
  - ✓ Truck

*Note: Unless otherwise indicated by customer, all orders are treated as "Standard Orders", and will ship within 24 hours. We will make every effort to ship "Air Shipments" the same day that the order is received, if prior to 2PM west coast time. "Stock Orders" must be so noted on fax or web forms.*



## Here's how to get help...

*Please have the model and serial number on hand when calling.*

### Parts Department

800-427-1244 Fax: 800-672-7877  
310-537-3700 Fax: 310-637-3284

### Mayco Parts

800-306-2926 Fax: 800-672-7877  
310-537-3700 Fax: 310-637-3284

### Service Department

800-478-1244 Fax: 310-537-4259  
310-537-3700

### MQ Power Service Department

800-835-2551 Fax: 310-638-8046  
310-537-3700

### Technical Assistance

800-478-1244 Fax: 310-631-5032

### Warranty Department

800-421-1244, Ext. 279 Fax: 310-537-1173  
310-537-3700, Ext. 279

### Multiquip's Main Phone Numbers

800-421-1244 Fax: 310-537-3927  
310-537-3700

## Place Your Parts Order Via Web or Fax For Even More Savings!

### Extra Discounts!

All parts orders which include complete part numbers and are received by our automated web parts order system, or by fax qualify for the following extra discounts:

Ordered via	Standard orders	Stock orders (\$750 list and above)
Fax	3%	10%
Web	5%	10%

### Special freight allowances when you order 10 or more line items via Web or Fax! \*\*

FedEx Ground Service **at no charge for freight**  
No other allowances on freight shipped by any other carrier.

NOTE: DISCOUNTS ARE SUBJECT TO CHANGE



**MULTIQUIP INC.**  
18910 WILMINGTON AVENUE  
POST OFFICE BOX 6254  
CARSON, CALIFORNIA 90749  
310-537-3700 • 800-421-1244  
FAX: 310-537-3927  
E-MAIL: mq@multiquip.com  
WWW: multiquip.com

## Direct TOLL-FREE access to our Parts Department:

Toll-free nationwide — 800-427-1244

# MDR-9D — SAFETY MESSAGE ALERT SYMBOLS

## FOR YOUR SAFETY AND THE SAFETY OF OTHERS!

Safety precautions should be followed at all times when operating this equipment. Failure to read and understand the Safety Messages and Operating Instructions could result in injury to yourself and others.

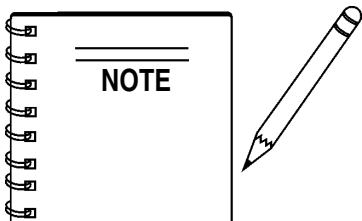

This Owner's Manual has been developed to provide complete instructions for the safe and efficient operation of the Multiquip Model MDR-9D Vibration Roller. Refer to the engine manufacturer's instructions for data relative to its safe operation.

**Before using this vibratory roller, ensure that the operating individual has read and understands all instructions in this manual.**

## SAFETY MESSAGE ALERT SYMBOLS

The three (3) Safety Messages shown below will inform you about potential hazards that could injure you or others. The Safety Messages specifically address the level of exposure to the operator, and are preceded by one of three words: **DANGER**, **WARNING**, or **CAUTION**.



**DANGER:** You **WILL** be **KILLED** or **SERIOUSLY** injured if you do not follow directions.



**WARNING:** You **CAN** be **KILLED** or **SERIOUSLY** injured if you do not follow directions.



**CAUTION:** You **CAN** be injured if you do not follow directions.

Potential hazards associated with this vibratory roller operation will be referenced with Hazard Symbols which appear throughout this manual, and will be referenced in conjunction with Safety Message Alert Symbols.

## HAZARD SYMBOLS



### Lethal Exhaust Gases

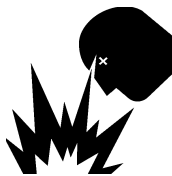

Engine exhaust gases contain poisonous carbon monoxide. This gas is colorless and odorless, and can cause death if inhaled. **NEVER** operate this equipment in a confined area or enclosed structure that does not provide ample free flow air.



### Explosive Fuel



**Diesel fuel** is extremely flammable, and its vapors can cause an explosion if ignited. **DO NOT** start the engine near spilled fuel or combustible fluids. **DO NOT** fill the fuel tank while the engine is running or hot. **DO NOT** overfill tank, since spilled fuel could ignite if it comes into contact with hot engine parts or sparks from the ignition system. Store fuel in approved containers, in well-ventilated areas and away from sparks and flames. **NEVER** use fuel as a cleaning agent.



### Burn Hazards



Engine components can generate extreme heat. To prevent burns, **DO NOT** touch these areas while the engine is running or immediately after operations. Never operate the engine with heat shields or heat guards removed.



### Rotating Parts



**NEVER** operate equipment with covers, or guards removed. Keep fingers, hands, hair and clothing away from all moving parts to prevent injury.

# MDR-9D — SAFETY MESSAGE ALERT SYMBOLS

## Accidental Starting



OFF

**ALWAYS** place the engine ON/OFF switch in the **OFF** position, when the vibration roller is not in use.

## Respiratory Hazard



**ALWAYS** wear approved respiratory protection.

## Sight and Hearing hazard

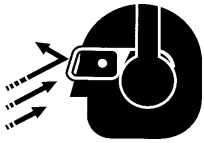

**ALWAYS** wear approved eye and hearing protection.

## Equipment Damage Messages

Other important messages are provided throughout this manual to help prevent damage to your vibration roller, other property, or the surrounding environment.

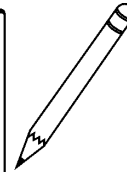
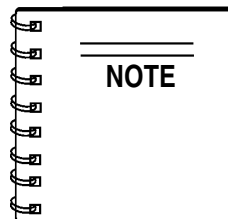

This vibratory roller, other property, or the surrounding environment could be damaged if you do not follow instructions.

# MDR-9D — RULES FOR SAFE OPERATION

## CAUTION:



Failure to follow instructions in this manual may lead to serious injury or even death! This equipment is to be operated by trained and qualified personnel only! This equipment is for industrial use only.

The following safety guidelines should always be used when operating the MIKASA MDR-9D Vibratory Roller.

### GENERAL SAFETY

- **DO NOT** operate or service this equipment before reading this entire manual.



- This equipment should not be operated by persons under 18 years of age.

- **NEVER** operate this equipment without proper protective clothing, shatterproof glasses, steel-toed boots and other protective devices required by the job. **ALWAYS** wear slip resistant safety shoes or boots.



- **NEVER** operate this equipment when not feeling well due to fatigue, illness or taking medicine.



- **NEVER** operate this equipment under the influence of drugs or alcohol.



- **NEVER** use accessories or attachments, which are not recommended by Multiquip for this equipment. Damage to the equipment and/or injury to user may result.

- Manufacturer does not assume responsibility for any accident due to equipment modifications.

- Whenever necessary, replace nameplate, operation and safety decals when they become difficult read.

- **ALWAYS** wear proper respiratory (mask), hearing and eye protection equipment when operating the vibratory roller.

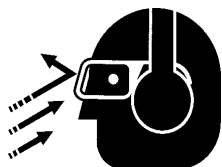

- **NEVER** touch the hot exhaust manifold, muffler or cylinder. Allow these parts to cool before servicing engine or vibratory roller.



- **High Temperatures** – Allow the engine to cool before adding fuel or performing service and maintenance functions. Contact with *hot* components can cause serious burns.

- The engine of this vibratory roller requires an adequate free flow of cooling air. **NEVER** operate the vibratory roller in any enclosed or narrow area where free flow of the air is restricted. If the air flow is restricted it will cause serious damage to the vibratory roller or engine and may cause injury to people and property. Remember the roller's engine gives off **DEADLY** gases.

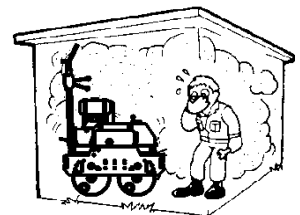

- **ALWAYS** refuel in a well-ventilated area, away from sparks and open flames.

- **ALWAYS** use extreme caution when working with **flammable** liquids. When refueling, **stop the engine** and allow it to cool. **DO NOT** smoke around or near the machine. Fire or explosion could result from fuel vapors, or if fuel is spilled on a hot engine.

- **NEVER** operate the vibratory roller in an explosive atmosphere or near combustible materials. An explosion or fire could result causing severe *bodily harm or even death*.

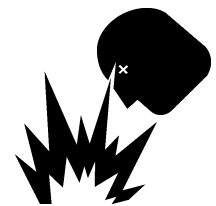

- Topping-off to filler port is dangerous, as it tends to spill fuel.

- **ALWAYS** store the vibratory roller in a clean, dry location out of the reach of children.

- **NEVER** run engine without air cleaner. Severe engine damage may occur.

- **NEVER** leave the vibratory roller unattended, turn off engine.

- **CAUTION** must always be observed while servicing this vibratory roller. Rotating parts can cause injury if contacted.

- **DO NOT** leave vibratory roller with engine running. Use chock blocks if parking vibratory roller on a grade.



# MDR-9D — RULES FOR SAFE OPERATION

- **NEVER** disconnect any "**emergency or safety devices**". These devices are intended for operator safety. Disconnection of these devices can cause severe injury, bodily harm or even death! Disconnection of any of these devices will void all warranties.

## Loading and Unloading (Crane)

- Before lifting, make sure that machine parts (hook and vibration insulator) are not damaged and screws are not loosened or lost.
- Always make sure crane or lifting device has been properly secured to the hook of guard frame on vibratory roller.
- **NEVER** lift the machine while the engine is running.
- Use adequate lifting cable (wire or rope) of sufficient strength.
- Use one point suspension hook and lift straight upwards.
- **NEVER** allow any person or animal to stand underneath the machine while lifting.
- Try not to lift machine to unnecessary heights.

## Transporting

- Always shutdown engine before transporting.
- Tighten fuel tank cap securely and close fuel cock to prevent fuel from spilling.
- Drain fuel when transporting vibratory roller over long distances or bad roads.
- Always tie-down the vibratory roller during transportation by securing the roller's guard frame with rope.

## Emergencies

- **ALWAYS** know the location of the nearest **fire extinguisher**.



- **ALWAYS** know the location of the nearest and **first aid kit**.



- In emergencies **always** know the location of the nearest phone or **keep a phone on the job site**. Also know the phone numbers of the nearest **ambulance, doctor** and **fire department**. This information will be invaluable in the case of an emergency.

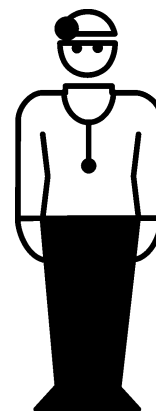
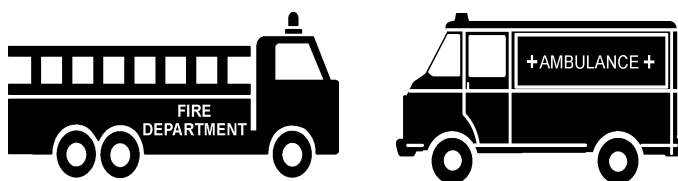

## Maintenance Safety

- **NEVER** lubricate components or attempt service on a running machine.
- **ALWAYS** allow the machine a proper amount of time to cool before servicing.
- Keep the machinery in proper running condition.
- Fix damage to the machine immediately and always replace broken parts.
- Dispose of hazardous waste properly. Examples of potentially hazardous waste are used motor oil, fuel and fuel filters.
- **DO NOT** use food or plastic containers to dispose of hazardous waste.
- **DO NOT** pour waste, oil or fuel directly onto the ground, down a drain or into any water source.

# MDR-9D — OPERATION AND SAFETY DECALS

Figure 1 displays the operation and safety decals as they appear on the vibratory roller. Should any of these decals become damaged or unreadable, contact the Multiquip Parts Department for a replacement set.

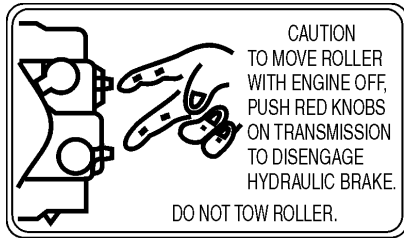

P/N: 920200440

*Mikasa*

P/N: 920101510



P/N: 920201590

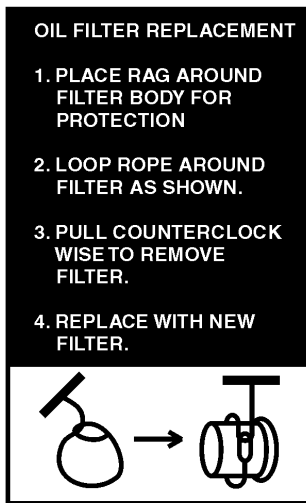

P/N: 920200450

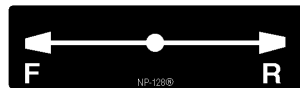

P/N: 920101280



P/N: 920101480

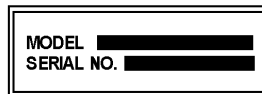

CONTACT SERVICE DEPT.

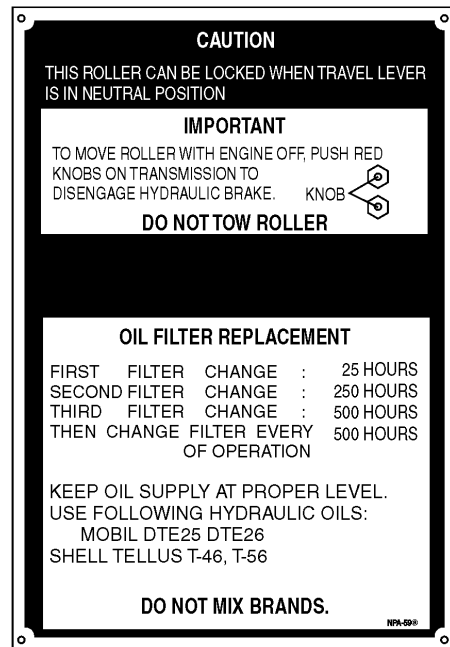

P/N: 902000591



P/N: 920101290



P/N: 920100120



P/N: 920200320

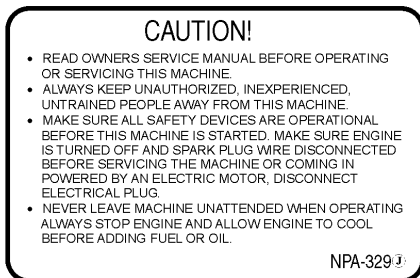

P/N: 920203290



P/N: 920200470



P/N: 920201100

Figure 1. Operation and Safety Decals

**Table 1. MDR-9D VIBRATORY ROLLER SPECIFICATIONS**

Starting Method	Crank Handle Start (MDR-9D) Electric Start (MDR-9DES)
Centrifugal Force	6,600 lbs. (3,000 kg)
Vibration Frequency	3,000 vpm
Traveling Speed (forward and reverse)	0 to 1.8 mph (0 to 3 km/hr)
Grade Ability	25°
Diameter x Width of Roller	18 x 27.6 in (457 x 700 cm)
Wheel Base	22.4 in (570 mm)
Side Road Clearance	10.8 in (274 mm)
Length (with Handle)	111.8 in (2,840 mm)
Width	31.3 in (795 mm)
Height	44.1 in (1,120 mm)
Total Weight	1,940 lbs. (880 kg)
Working Input Revolution	2,000 rpm
Continuous Rated Pressure	1,500 psi (105 kg/cm <sup>2</sup> )
Oil Tank Capacity	4 gallons (15 liters)
Water Tank Capacity	6 gallons (23 liters)
Working Ability	2,100 m <sup>2</sup> /hr

**Table 2. ENGINE SPECIFICATIONS**

	<b>Model</b>	<b>Hatz 1D81Z</b>
<b>Engine</b>	Type	Air-cooled, 4-Stroke, Single Cylinder, Diesel Engine
	Bore X Stroke	3.94 in. X 3.34 in. (100 mm x 85 mm.)
	Displacement	40.70 cu-in (667 cm <sup>3</sup> )
	Max Output	15.0 H.P./3600 R.P.M.
	Fuel Tank Capacity	1.85 gallons (7.0 liters)
	Fuel	Diesel #2
	Lube Oil Capacity	1.8 quarts (1.7 liters)
	Starting Method	Crank Handle/Electric
	Battery min./max. Ah	12V 45/70 Ah
	<b>Dimension (L x W x H)</b>	14.31 x 19.62 X 23.00 in. (363.5 X 498.5 X 584.5 mm.)
<b>Dry Net Weight</b>	201 lbs. (91 Kg.)	

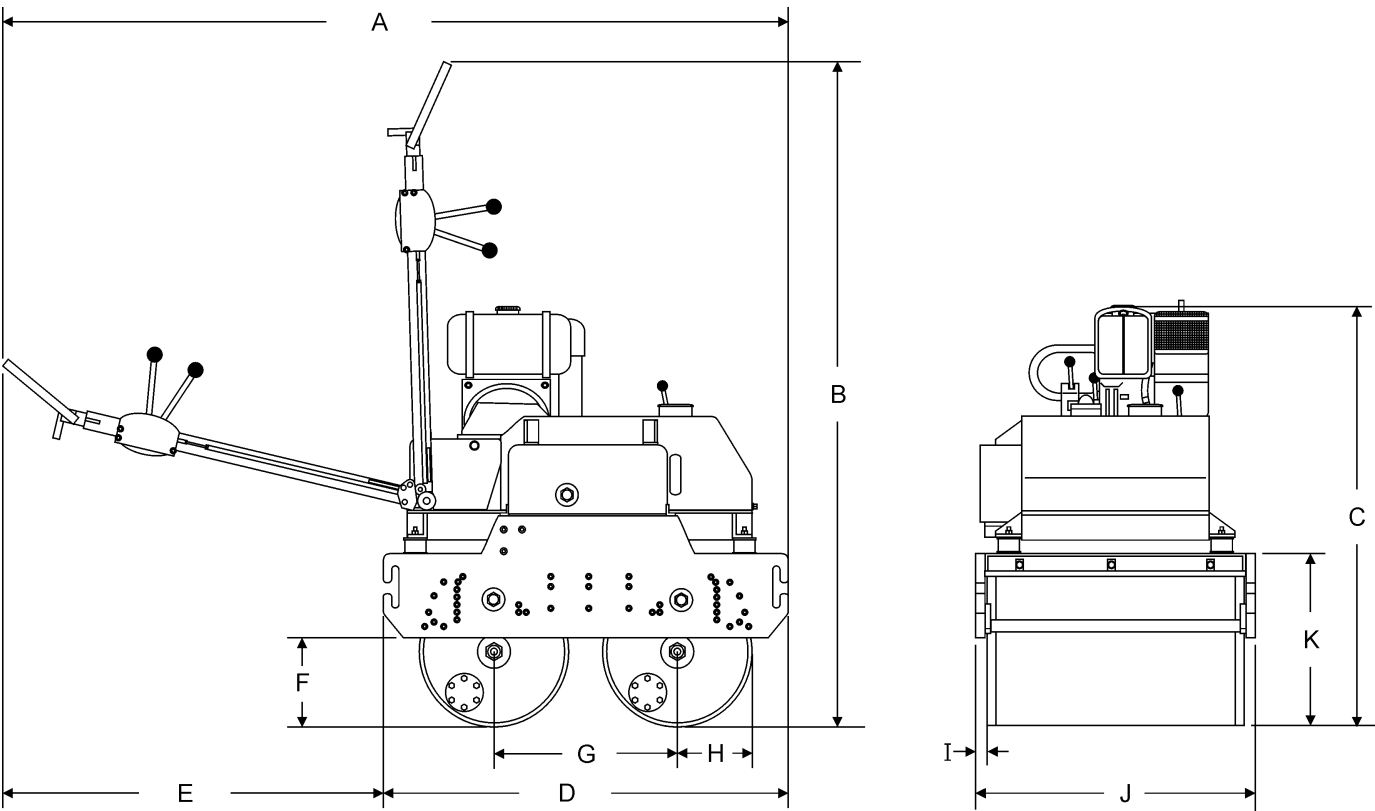

**Figure 2. MDR-9D Vibratory Roller Dimensions**

TABLE 3. ROLLER DIMENSIONS			
REF.	DIMENSIONS	REF.	DIMENSIONS
A	111.8 in. (2.8 meters)	F	22.4 in. (.57 meters)
B	88 in. (2.23 meters)	G	18 in. (.457 meters)
C	46 in. (1.17 meters)	H	15.5 in. (.382 meters)
D	45.9 in. (1.16 meters)	I	5.4 in. (.137 meters)
E	11 in. (.279 meters)		



# MDR-9D — GENERAL INFORMATION

The Mikasa Model MDR-9D is a powerful compacting tool capable of applying a tremendous force in consecutive impacts to a soil surface. With 28-inch drums and 32 inches overall width, virtually any asphalt or mixed granular soil compaction job is quickly cut down to size.

The impact force of the MDR-9D levels and uniformly compacts voids between soil particles to increase dry density.

Features include:

- Hydraulic variable speed transmission assures easy handling.
- Deadman device which when pressed or hit will cause the travel lever to return to neutral position bringing the machine to a stop.
- Non-corrosive water tank for the sprinkler system with a capacity of 6 gallons.
- Simple dual-lever controls assure operator safety and convenience.
- Sight gauge for hydraulic oil tank.
- Front-mounted auxiliary travel lever.
- Four large rubber shock mounts minimize vibrations to the engine and hydraulics.
- Convenient tie-downs, front and rear.
- Scraper Bar.
- Drum sprinkler system.
- Handle folds to 90 degrees for storage and transport..

## FREQUENCY/SPEED

The vibrating roller maximum frequency is 3000 vpm (vibrations per minute). The forward and reverse travel speed of the vibratory roller is approximately 1.8 mph (3 km/hour).

## ENGINE

The Mikasa MDR-9D Vibratory Roller is equipped with a Hatz 1D81Z.

## CONTROLS

Before starting the MDR-9D Vibratory Roller, identify and understand the function of the controls and components as indicated in Figure 6.

## TRANSPORTATION

Adjustable transport hooks allow an operator to place the roller on the tailgate of a dump truck without any assistance. The control handle of the MDR-9D Vibratory Roller can be folded vertically for ease of transport and storage.

## LIFTING THE ROLLER

When lifting of the roller is required (Figure 3), attach a suitable hook or shackle to the **lifting hooks** of the roller. Make sure the lifting device is capable of lifting 1,940 lbs (880 kg).

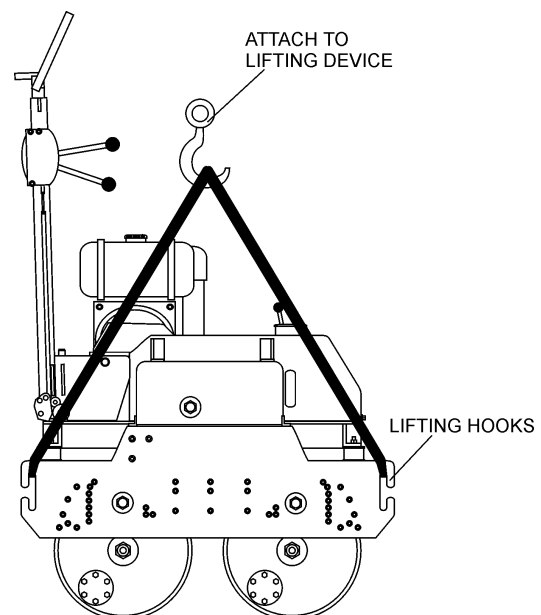

NOTE: USE LIFTING HOOKS ON BOTH SIDES WHEN LIFTING

Figure 3. Lifting The Roller

# MDR-9D — GENERAL INFORMATION

## CAUTION :



**NEVER!** stand under, or get onto the roller while it is being lifted or moved.

## CAUTION :



**ONLY!** use steel ropes or chains that are capable of lifting at least 1,940 lbs. (880 kg).

## CAUTION :



**NEVER!** use any other part of the roller for lifting purposes. Use the lifting eye. Using other parts of the roller for lifting will cause severe damage to the roller,

## OPERATING ON SLOPES

Special care must be taken when operating the roller on hills or slopes. There exist the possibility of serious injury to the operator and severe damage to the roller in the event of a roll over. **ALWAYS** operate the roller up and down hills rather than from side to side. For safe operation hillside slopes should not exceed 12 degree (21 % grade). See Figure 4 below.

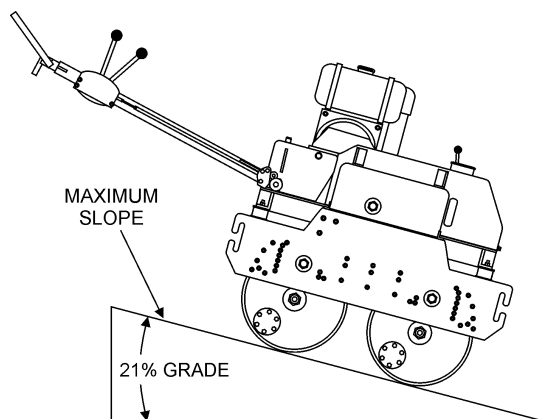

Figure 4. Recommended Slope

## Tipping (Rollovers)

**NEVER!** operate the roller on side slopes (Figure 5). The possibility exist that the roller could tip over (roll over), thus causing bodily harm even death and serious damage to the equipment.

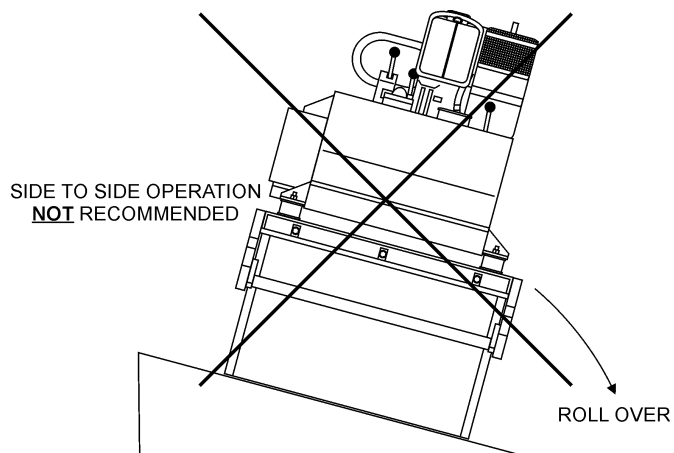

Figure 5. Recommended Slope

In the event the roller does tip over, extreme care must be taken to prevent damage to the engine. When the roller has been tipped over, oil from the engine crankcase can flow into the combustion chamber, which can severely damage the engine the next time it is started.

**IMMEDIATELY** after a unit has tipped over upright the unit as soon as possible to prevent oil from leaking into the combustion chamber.

## CAUTION :



To prevent damage to the engine after a rollover, the unit must **NOT** be started. **NEVER** start a unit after a rollover. **CONTACT** your nearest authorized Multiquip dealer for instructions or servicing.

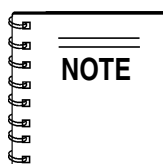

**NEVER!** operate the roller on *side slopes*. The roller may tip over causing injury to personnel and severe damage to the equipment

# MDR-9D — VIBRATORY ROLLER COMPONENTS

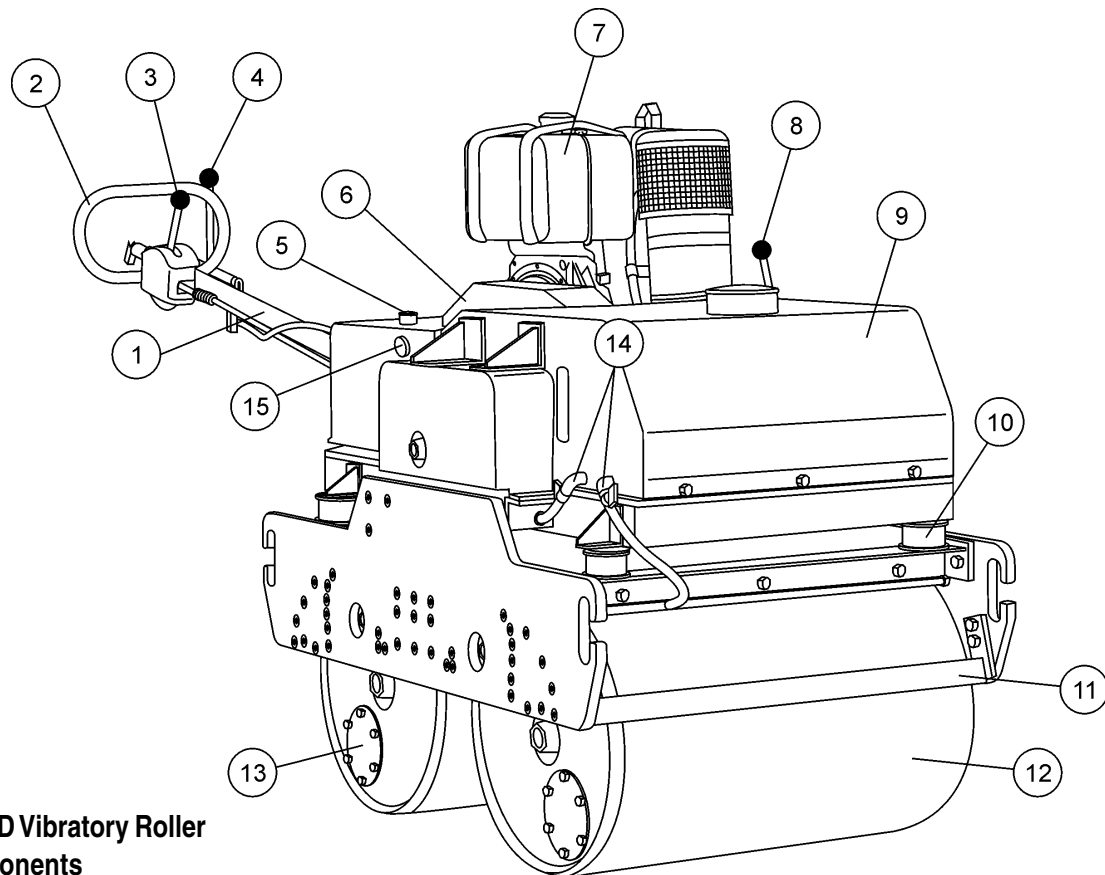

**Figure 6. MDR-9D Vibratory Roller Components**

Figure 6 illustrates the location of the major components for the MDR-9D Vibratory Roller. The function of each component is described below:

1. **Handle Bar** – When operating the roller, this handle is to be in the downward position. When the roller is to be **stored**, move the handle bar to the upright position.
2. **Hand Grip** – When operating the roller, use this hand grip to maneuver the roller. Also has dead man device, when pressed or hit while traveling in reverse, causes the travel lever to return to neutral position to stop the machine.
3. **Travel Lever** – **Push** the lever forward, the roller will move in a forward direction, **pull** the lever backwards, the roller will move in backwards direction. Placing the lever in the middle (midway) will cause the roller not to move (neutral).
4. **Vibrator Lever** – Turns the vibration on and off.
5. **Hydraulic Oil Tank/Cap** – Stores hydraulic fluid. Open cap to fill with recommended hydraulic oil (Shell Tellus #46).
6. **V-Belt Cover** – Remove this cover to gain access to the v-belts. **NEVER** run the vibratory roller without the v-belt cover. If the v-belt cover is not installed, the possibility exist that your hand may get caught between the v-belt and clutch, thus causing serious injury and bodily harm.
7. **Engine** – This vibratory roller uses a **HATZ 1D81Z** diesel engine. Refer to the owner's manual for engine information and related topics.
8. **Vibrator Lever (on the body of machine)** – Turns the vibration on and off.
9. **Water Tank** – Holds 6 gallons (23 liters) of water for the sprinkler system.
10. **Shock Absorber** -
11. **Scraper Bar** – This bar helps prevent buildup of material between the drum and the frame.
12. **Vibration Rollers** – 18-inch diameter steel drums that provide the compaction force in the compaction and patching of asphalt-type surfaces.
13. **Checking Cover for Chains** – Take off the cover to check and lubricate chains.
14. **Water Valves**– Turn on the water sprinkling system.
15. **Hydraulic Oil Gauge** – Indicates the hydraulic oil level.



# MDR-9D — HATZ 1D81Z ENGINE COMPONENTS

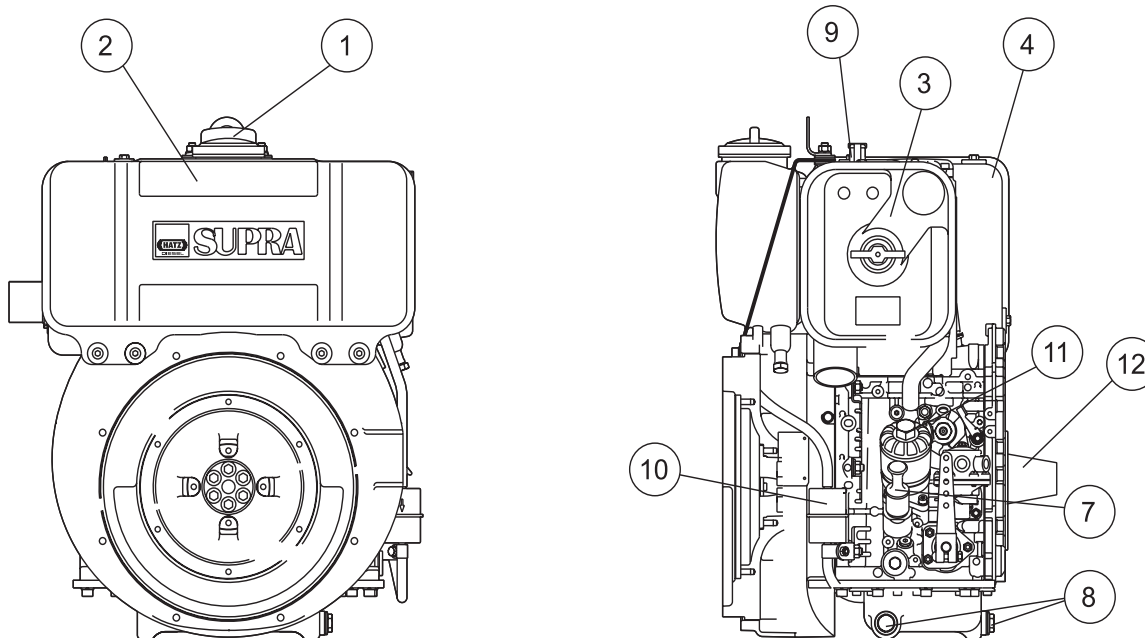

Figure 7. HATZ 1D81Z Engine Components

## ENGINE COMPONENTS

Figure 7 illustrates the location of the major engine components of the machine. Each component is described below:

1. **Fuel Filler Cap** – Remove this cap to add diesel fuel to the fuel tank. Make sure cap is tighten securely. **DO NOT** over fill.



**! DANGER**

Adding fuel to the tank should be done only when the engine is stopped and has had an opportunity to cool down. In the event of a fuel spill, **DO NOT** attempt to start the engine until the fuel residue has been completely wiped up, and the area surrounding the engine is dry.

2. **Fuel Tank** – Diesel engine holds 5.8 quarts of diesel fuel.
3. **Air Cleaner** – Prevents dirt and other debris from entering the fuel system. Remove wing-nut on top of air filter cannister to gain access to filter element.

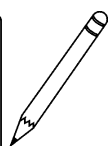
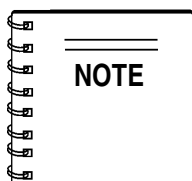

Operating the engine without an air filter, with a damaged air filter, or a filter in need of replacement will allow dirt to enter the engine, causing rapid engine wear.

4. **Muffler** – Used to reduce noise and emissions.



**! WARNING**

Engine components can generate extreme heat. To prevent burns, **DO NOT** touch these areas while the engine is running or immediately after operating. **NEVER** operate the engine with the muffler removed.

7. **Oil Filler Cap/Dipstick** – Remove this cap to add oil to the oil tank. Use dipstick to check oil level.
8. **Oil Drain Plug** – Unscrew plug to drain oil from engine crankcase. Dispose of oil in a safe manner.
9. **Decompression Lever** – Press down before starting engine. To prevent damage to the engine, **DO NOT** use for any other purpose.
10. **Fuel Filter** – Controls the flow of diesel fuel to the carburetor. Must be in the ON position when starting and running the engine.
11. **Oil Filter** – filters oil for contaminates. Replace as necessary.
12. **Starting Handle Guide Sleeve** – Insert starting handle into the guide sleeve and turn to crank start engine.

## CAUTION :



Never operate the vibratory roller in a confined area or enclosed structure that does not provide ample **free flow of air**.



**ALWAYS** wear approved eye and hearing protection before operating the vibratory roller.

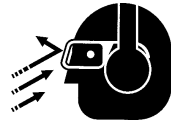

## BEFORE STARTING

1. Read safety instructions at the beginning of manual.
2. Familiarize yourself with the operating and control elements of the machine and the working environment. This includes obstacles in the working area, bearing capacity of the ground and the necessary safety provisions.
3. Check the air filter for dirt and dust. If the air filter is dirty, replace air filter with a new one as required.
4. Check fastening nuts and bolts for tightness. Loose threads may cause damage to the machine when vibrating.
5. Understand the geographical features and regulations of the job site.
6. Clean the vibratory roller, removing dirt and dust, particularly, the bottom of the plate, engine cooling air inlet.



## CHECKING ENGINE OIL LEVEL

1. Make sure that the machine is situated in a flat surface so that level measurements will be accurate.
2. Pull out the dipstick from the oil tank (Figure 8).

## CAUTION :



**DO NOT** overfill oil tank. This could cause oil leaks and sluggish operation. Clean cap and surrounding area before opening to prevent dirt from entering tank.

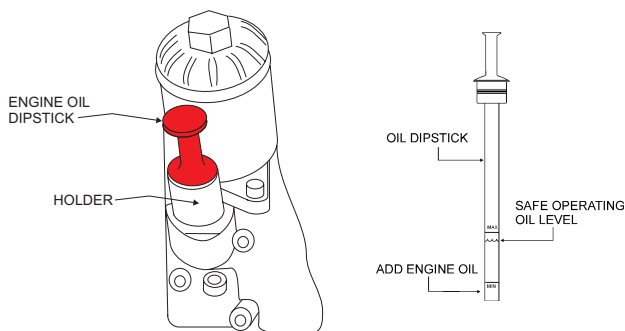
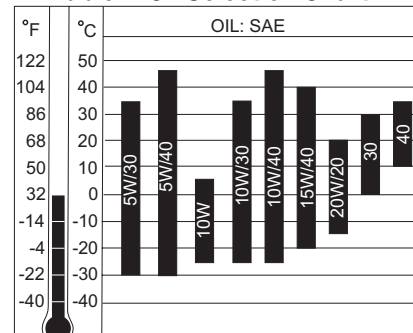

Figure 8. Oil Dipstick

3. If the oil level is low, fill to the edge of the oil filler hole with the recommended oil type (Table 4). Maximum oil capacity is 2 quarts (1.9 liters).

Table 4. Oil Selection Chart



**Explosive Fuel**

## DANGER



Diesel fuel is highly flammable and can be dangerous if mishandled. **DO NOT** smoke while refueling. **DO NOT** attempt to refuel the vibratory roller if the engine is **hot!** or **running**.

## CHECKING FUEL

1. Remove the fuel cap located on top of fuel tank.
2. Visually inspect to see if fuel level is low. If fuel is low, replenish with diesel fuel (Figure 9).
3. When refueling, be sure to use a strainer for filtration. **DO NOT** top-off fuel. Wipe up any spilled fuel.

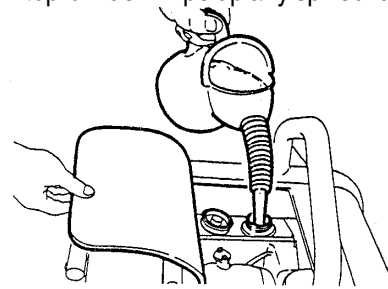

Figure 9. Refueling

## DANGER



Fuel spillage on a hot engine can cause a **fire** or **explosion**. If fuel spillage occurs, wipe up the spilled fuel completely to prevent fire hazards. **NEVER!** smoke around or near the roller.



## CHECKING HYDRAULIC SYSTEM

1. Check the oil tank level gauge (Figure 10). Oil level should be at the middle indication of the gauge or higher. Fill as required
2. Check the surroundings of the oil tank, hydraulic pump and motor for oil leakage.

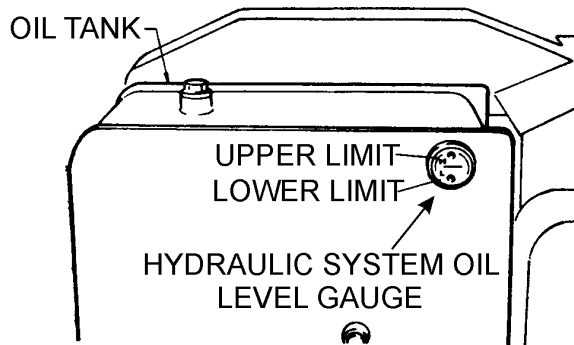

Figure 10. Hydraulic System Oil Level Gauge

## DANGER



**ALWAYS** keep hands and fingers away from pinch points. **DO NOT** allow anyone to reach in on dangerous sections of the machine to avoid any accidents.

## CHECKING THE V-BELT

1. Check all bolts and screws and make sure all are securely tightened.
2. Check V-belt for proper tension. The normal slack should be approximately 1/8 inch (3 to 5 mm) when the belts are forcibly depressed between the two sheaves (Figure 11). Insufficient tension causes weak vibration and machine damage.

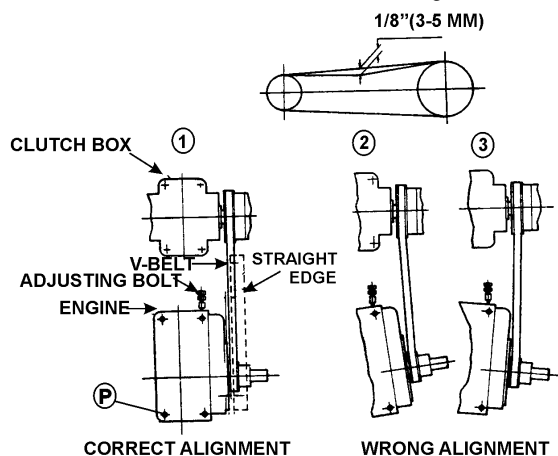

Figure 11. V-Belt Tension

## CHECKING THE CLUTCH BOX OIL LEVEL

1. Check clutch box for any oil leakage.
2. Remove the level plug and check oil level (Figure 12).
3. Add oil if necessary.

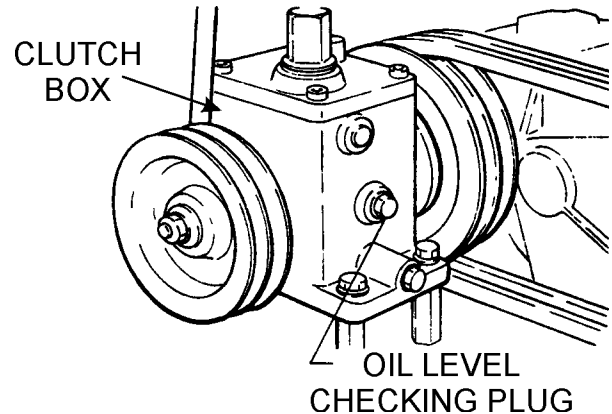

Figure 12. Clutch Box Oil Level Check

## CHECKING THE VIBRATOR OIL LEVEL

1. Remove the red filler plug and the oil level inspection hole plug from the vibrator case (Figure 13).
2. Fill with oil until oil overflows from inspection hole.

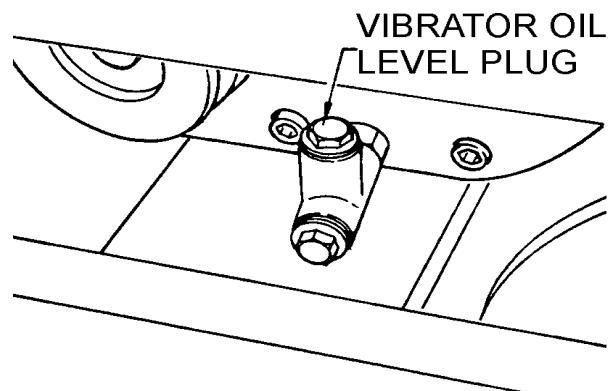

Figure 13. Vibrator Oil Level Check

## CHECKING WATER TANK

1. Check the water tank to see if filled. Add water if necessary. The water tank has a capacity of approximately 6gallons (23 liters) (Figure 14).

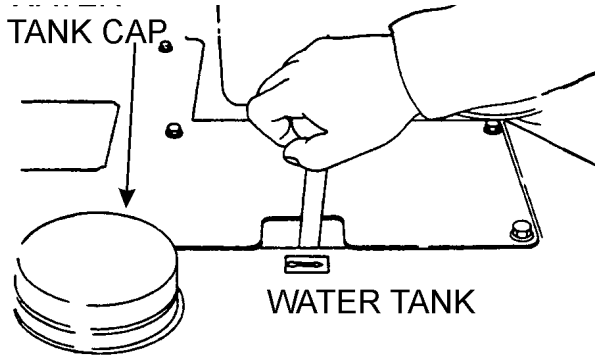

Figure 14. Water Tank Check

## CAUTION



Be careful not to confuse the water tank with the oil tank.

## CHECKING LEVERS

1. Check travel and vibrator levers to make sure they are functioning properly (Figure 6).
2. With travel lever placed in reverse, push the deadman device and verify that the travel lever returns to neutral position. The travel lever stays in neutral position once the deadman device is released.

## CHECKING SCRAPER BAR

1. Check scraper bar and make sure that they are not clogged with mud, bent or damaged (Figure 6).
2. Adjust clearance between drums and scrapers as necessary.

## CHECKING BOLTS, NUTS, AND SCREWS

1. Check bolts, nuts, and screws on various parts of the machine, including the engine, for proper tightness.

## POSITIONING THE HANDLE BAR

1. Release the handle bar release pin (Figure 15) and position the handle bar to the lowered position before starting operation.
2. When machine is not in use, release the handle bar release pin and position the handle bar to the upright position.

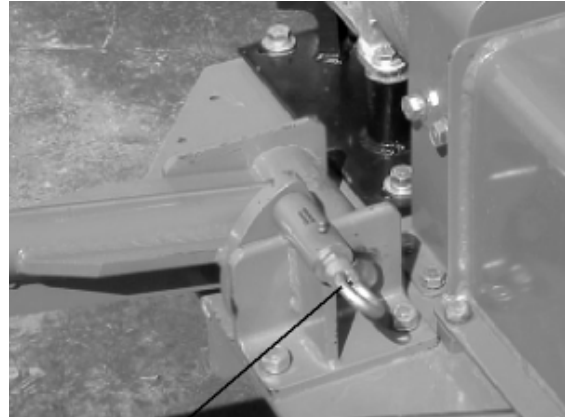

Handle Bar Release Pin

Figure 15. Handle Bar Positioning

## INITIAL STARTUP (Crank Handle Start)

1. Set the **Speed Control Lever** (Figure 16) to a position half way between start and stop.

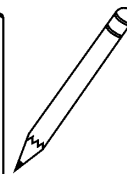
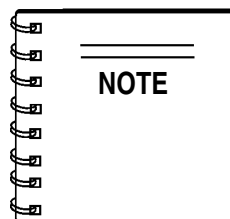

Selecting a lower engine speed will reduce smoke when starting.

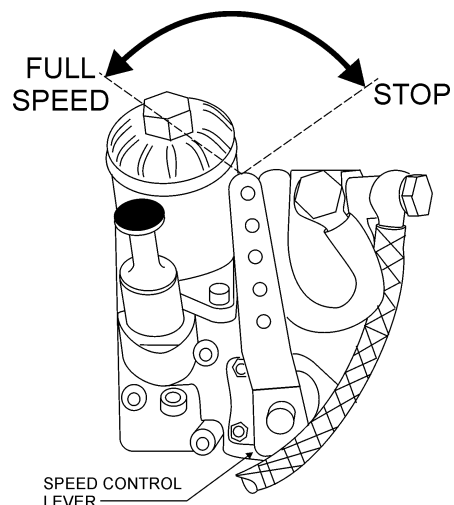
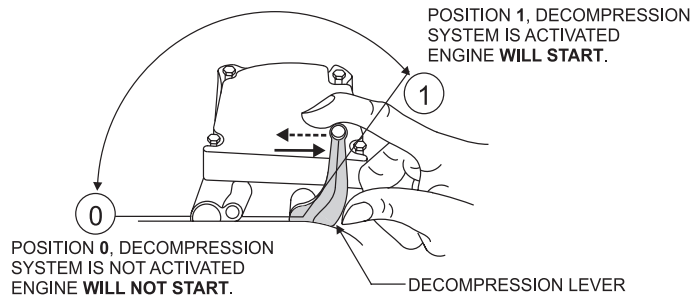

Figure 16. Speed Control Lever

- Pull up decompression lever (Figure 17) to position 1 and release.



**Figure 17. Decompression Lever**

- Insert the starting handle into the engine's starting handle guide sleeve (Figure 18).

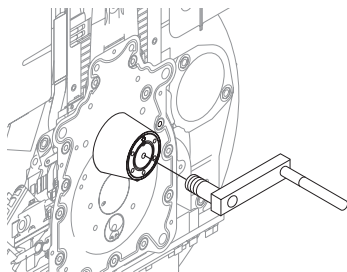

**Figure 18. Starting Handle Guide Sleeve**

- When turning the starting handle, observe the correct operating position (Figure 19).

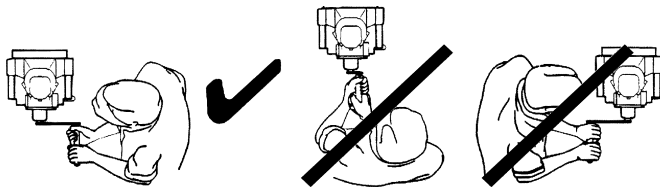

**Figure 19. Starting Handle Operating Position**

- Grasp the starting handle firmly in both hands and turn counterclockwise at increasing speed. Five turns of the starting handle are needed to build up enough compression to start the engine.
- Once the engine starts, stop cranking and remove the starting handle from the guide sleeve.

## CAUTION :



There is a risk of injury from the rotating starting handle. When using the starting handle, keep the body clear of the handle to avoid being struck. If the engine backfires because the handle was not turned firmly enough release the starting handle immediately and stop the engine.

## Electric Start

- Turn the key to the "START" position until the engine starts. If the engine fails to start within 5 seconds, release the key, and wait at least 10 seconds before operating the starter again

## TRAVELING

### CAUTION



Make sure to follow all safety rules referenced in the safety section of this manual before operating roller. Keep work area clear of debris and other objects that could cause damage to the roller or bodily injury.

- To make the roller move in the forward direction push the travel lever ( Figure 20) forward. This roller has a hydraulic variable speed transmission. By moving the travel lever varies increments, you can vary the speed from 0 to 1.8 mph (0 to 3 km/hr).

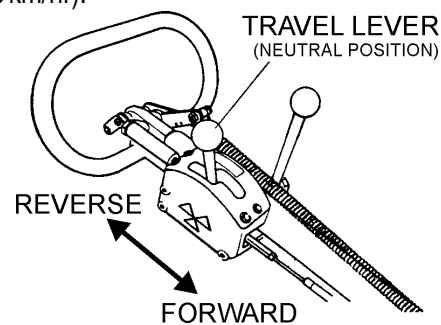

**Figure 20. Travel Lever**

- To make the roller move in the reverse direction pull the travel lever ( Figure 20) backwards.
- Firmly gasp the roller's hand grip, the roller will begin moving in the desired position when the direction lever has been placed in the desired position.

### CAUTION



**DO NOT** reduce speed during work. When shifting travel lever from forward to reverse, be sure to stop the lever at the neutral position first before moving the lever to the opposite direction. **DO NOT** shift the lever from forward to reverse (or reverse to forward) in one motion.

### CAUTION



After test travel, shut down engine and check for any problems including oil leakage. If any trouble is found, correct the problem before attempting to operate the roller again.

## VIBRATING

1. Shift the two vibrator levers (Figures 21 and 22) to the vibrate position to start vibrations.

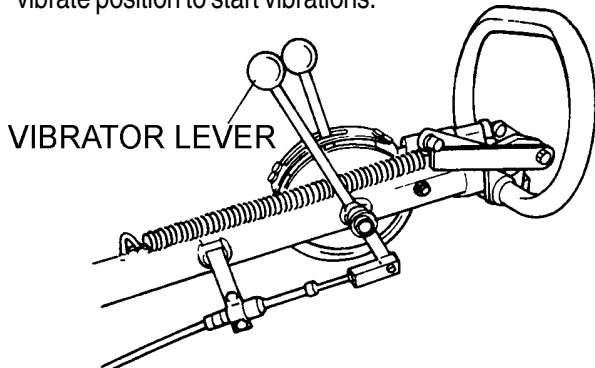

Figure 21. Vibrator Lever

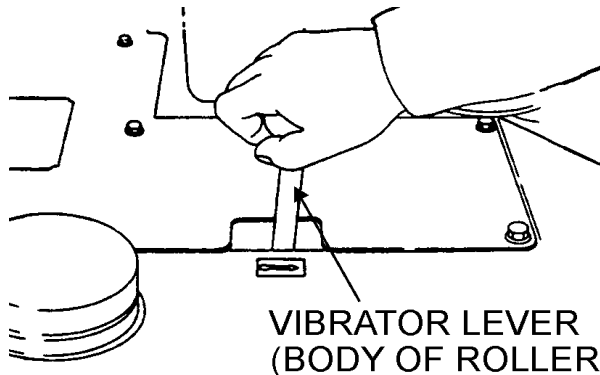

Figure 22. Vibrator Lever (Body)

## CAUTION :



Using vibration with clutch slipping causes the clutch to burn. Also, vibration should **NOT** be used over completely compacted area, paved road surface, or with stationary roller.

## WATERING

1. To operate water sprinkling system, turn on the front and rear water valves on the side of the roller. (Figure 23).

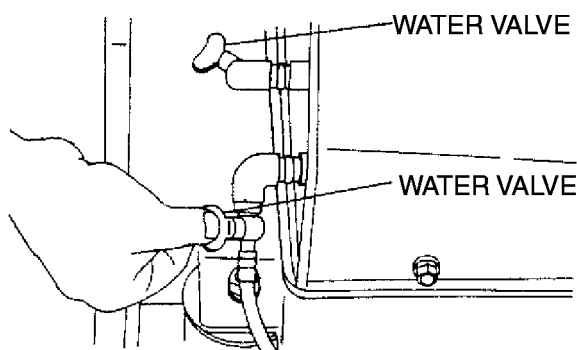

Figure 23. Water Valves

## STOPPING

1. Place the vibrator and travel levers to the neutral position.
2. Slow down the engine and allow to cool for at least 2 minutes. Place **speed control lever** in the stop position and listen for the engine to stop running.

## CAUTION :



**NEVER** attempt to stop the engine by moving the decompression lever. Always use the speed control lever to stop engine.

3. The hydraulic brake is automatically engaged when the travel lever is in neutral position. When parked on a slope with the engine turned off, place a block against the roller drum to prevent the roller from moving.

## UNLOADING

1. If you need to move the roller by pushing it manually once engine is stopped, push in the upper and lower knobs of the transmission check valve. This will cause the hydraulic break to disengage and allow the roller to be moved without causing damage (Figure 24).

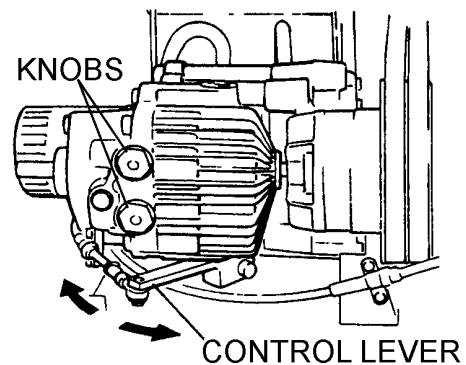

Figure 24. Disengaging Hydraulic Brake

2. After moving, reset upper and lower knobs.

## CAUTION :



**NEVER** tow roller with any type of vehicle. Doing so will damage the hydraulic system.

**NEVER** perform unloading procedure on a slope. This may cause roller to roll down if parking brake or blocking is deficient.

## LIFTING

1. Use a crane or lift to load and unload the machine. A skilled crane operator is required to perform the job.
2. When lifting the machine, check for any damaged or loose bolts, lifting hooks, and shock mounts.
3. Check any damaged or loose bolts in the guard frame to avoid machine sliding off.
4. Make sure that the machine is shut off before machine is lifted.
5. Use reliable cable for lifting.
6. Always lift the machine vertically and keep the machine away from workers and animals.
7. Do not lift the machine higher than the required height.

## TRANSPORTING

1. Always make sure that the machine is shut off while being transported.
2. Check that the fuel cap is properly closed and tightened.
3. When traveling long distances or on rugged terrain, drain the fuel of the machine before transporting.
4. Tie down the machine securely on the transportation so that it will not move or topple over.

## CAUTION:



Inspection and other services should **always** be carried out on hard and level ground with the engine shutdown.

### INSPECTION AND MAINTENANCE SERVICE TABLES

- To make sure your plate vibratory roller is always in good working condition before using, carry out the maintenance inspection in accordance with Tables 4 through 6.

**TABLE 5. MDR-9D MACHINE INSPECTION**

ITEM	HOURS OF OPERATION	REMARKS
Loose or Missing Screws	Every 8 hours (every day)	
Damaged Parts	Every 8 hours (every day)	
Function of Controlling System Part	Every 8 hours (every day)	
Chain Tension Adjustment	Every 50 hours	See page 26
Hydraulic Oil Filter Replacement	Initially after 25 hours, then every 250 hours (2 months), every 500 hours (4 months), every 1,000 hours thereafter.	See page 28
Hydraulic Oil Check	Initially, every 4 to 5 hours. After one week, twice a day. After 2 weeks, once a day.	See page 27
Hydraulic Oil Replacement	Every 1,000 to 1,500 hours	See page 27
Vibration Clutch Check	As necessary	See page 27

## CAUTION:



These inspection intervals are for operation under normal conditions. Adjust your inspection intervals based on the number hours vibratory roller is in use, and particular working conditions.

## CAUTION:



Fuel piping and connections should be replaced every 2 years.

**TABLE 6. MDR-9D ENGINE CHECK**

ITEM	HOURS OF OPERATION
Oil or Fuel Leak	Every 8 hours (every day)
Tightness of Fastening Threads	Every 8 hours (every day)
Engine Oil Check and Replenishment	Every 8 hours (every day) (Replenish to specified maximum level)
Air Filter Cleaning	Daily
Engine Oil Replacement	After first 25 hours then every 250 hours
Engine Oil Filter Replacement	Every 250 hours
Fuel Filter Replacement	Every 500 hours
See separate engine manual for details on engine check.	

### DAILY SERVICE

- Check for leakage of fuel or oil.
- Check for loose screws including tightness. See Table 6 below (tightening torque), for retightening:

**TABLE 7. TIGHTENING TORQUE (in. kg/cm) DIAMETER**

Material	6mm	8mm	10mm	12mm	14mm	16mm	18mm	20mm
4T	70	150	300	500	750	1,100	1,400	2,000
6-8T	100	250	500	800	1,300	2,000	2,700	3,800
11T	150	400	800	1,200	2,000	2,900	4,200	5,600
*	100	300~350	650~700					

\* (In case counter-part is of aluminum)  
(Threads in use with this machine are all right handed)  
Material and quality of material is marked on each bolt, and screw.

- Remove soil and clean the bottom of roller.
- Check the levers, cables and linkage.
- Check engine oil.



## CHECKING ENGINE OIL LEVEL

Check the engine crankcase oil level prior to each use, or when the fuel tank is filled. Make sure the pump is level. The oil level must be between the two notches on the dipstick as shown in Figure 25.

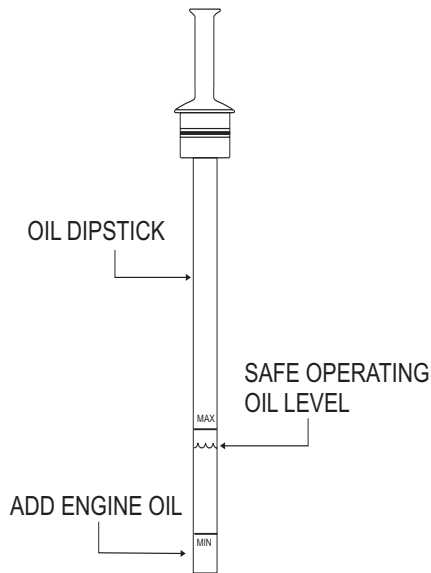

**Figure 25. Engine Oil Dipstick**

## CHANGING ENGINE OIL

Change engine oil after first 25 hours of operation. Drain and refill engine crankcase with the correct type and amount oil (reference Table 3) after 250 hours of operation hours or once a week thereafter.

When draining engine crankcase oil, place oil into a suitable container while engine is still warm. Replace the drain plug tightly. Add oil through the filler hole.

## CHANGING ENGINE OIL FILTER

Change the engine oil filter (Figure 26) and gasket after 250 hours of operation. To gain access to the oil filter element, unscrew the oil filter cap and replace the oil filter element. Make sure to tighten oil filter cap securely.

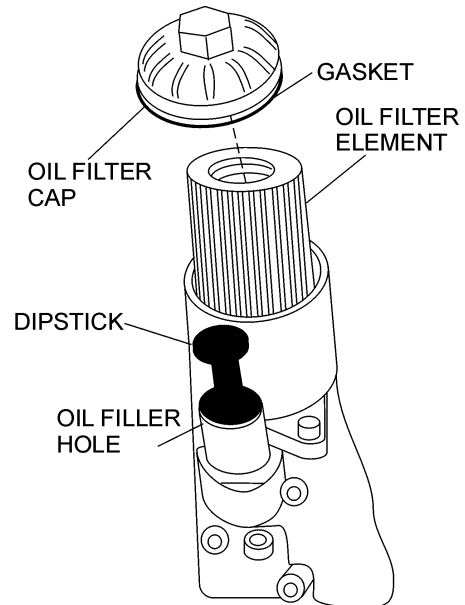

**Figure 26. Oil Filter Element**

## CHANGING ENGINE FUEL FILTER

Replace fuel filter (Figure 27) and drain fuel tank to remove water and sediment every 500 hours. If the purity of the fuel being used is of lesser quality replace fuel filter more often as needed.

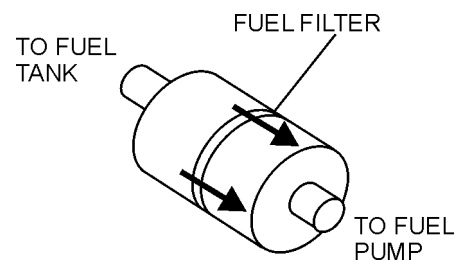

**Figure 27. Fuel Filter**

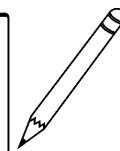
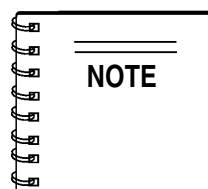

When re-installing fuel filter, please note the arrows indicating the direction of fuel flow.

## TESTING ENGINE AIR FILTER BLOCKAGE INDICATOR

To test the air cleaner blockage indicator (Figure 28) run the engine at full speed for a short time. If the rubber bellows is pulled inwards (down), and the green rubber band cannot be seen, this implies that maintenance work is required on the air cleaner. Clean or replace air cleaner.

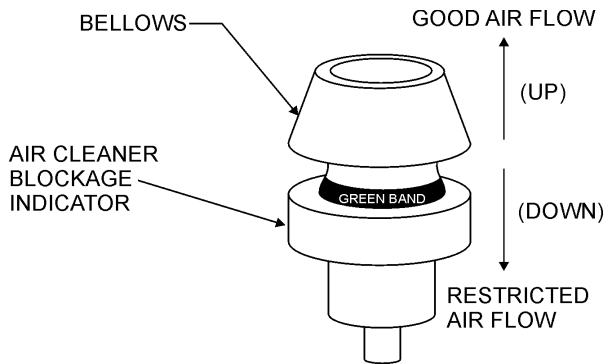

**Figure 28. Air Filter Blockage Indicator**

## CLEANING OR CHANGING ENGINE AIR FILTER

If engine is operating in very dusty and dry grass conditions. A clogged air filter will result in high fuel consumption, loss of power and excessive carbon buildup in the combustion chamber. Clean air filter daily. Remember if operating in dusty conditions, check the rubber bellows on the air blockage indicator several times a day.

## CAUTION :



**DO NOT** blow high pressure, high velocity compressed air thru the air filter cartridge. The high velocity air will damage the filter, which will then allow contaminants to pass into the engine.

To clean or replace air filter loosen the wing nut on the air filter housing (Figure 29), remove the cover and take out air filter cartridge. If only cleaning of the air filter is desired blow through the air filter cartridge from the inside, moving a jet of dry compressed air up and down until all dust is removed.

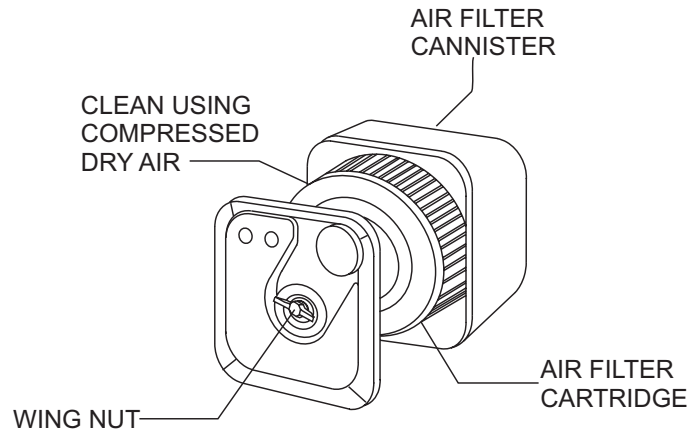

**Figure 29. Air Filter**

## CHECKING THE CHAINS

1. Take off the checking cover on roller and coat grease on the chain if necessary (Figure 30). The chain should be lightly lubricated with motor oil.

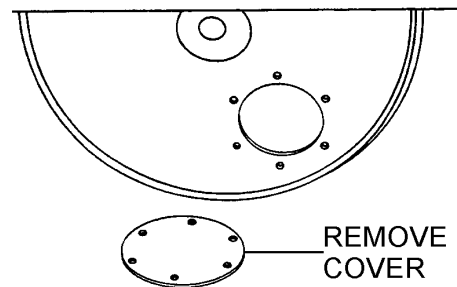

**Figure 30. Chain Cover**

2. Check the chain tension and if loose, adjust the chain tension with the tightener (Figure 31). Chain tension should be adjusted every 50 hours of operation.

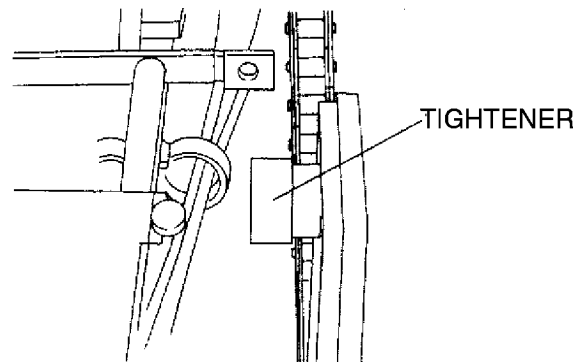

**Figure 31. Chain Tightener**

## CAUTION:



**NEVER** attempt to check the V-belt with the engine running. Severe injury can occur if your hand gets caught between the V-belt and the clutch (Figure 32). Always use safety gloves.

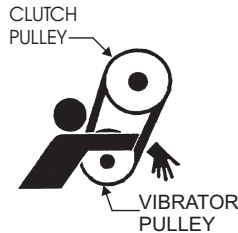

Figure 32. V-Belt Hazard

## VIBRATION CLUTCH ADJUSTMENT

1. Remove the protective cover from the clutch by removing the 4 allen screws.
2. Pull out the stop key and turn to the release position (Figure 33).
3. Viewing the clutch from the shifter-pulley side: if the clutch nut is turned to the right, the clearance between the adjusting and pressure plate decreases as the amount of torque increases. Normal adjustment is from 1 to 2 notches.
4. Make sure that the shifting lever is not too stiff. Lever should engage with moderate pressure.
5. After adjustment, return the stop key to the locked position.

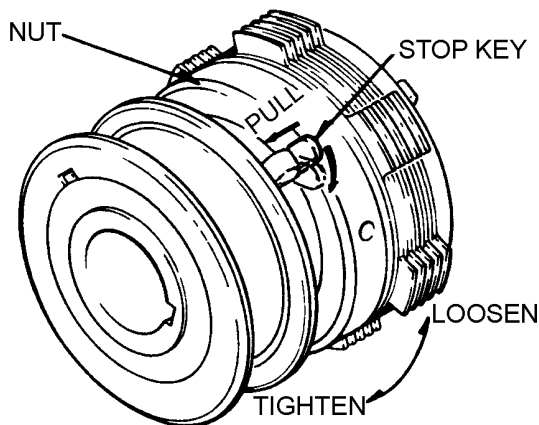

Figure 33. Clutch Adjustment

## HYDRAULIC OIL CHECK

1. Check for any oil leakage from the hoses and joints daily.
2. Check hydraulic oil level every 4 to 5 hours after starting operation.
3. After one week of operation, check hydraulic level twice a day .
4. After two weeks of operation, check hydraulic level once a day .
5. Replace hydraulic oil after first 200 hours and in every 1,000 hours of operation.

## CAUTION:



Make sure hydraulic oil is at a normal safe operating level. **DO NOT** over fill.

## REPLACING HYDRAULIC OIL

1. Change the hydraulic oil every 1,000 to 1,500 hours of operation. Change the hydraulic oil more often in high ambient temperature operation.
2. Remove the drain plug and hose tank and drain the hydraulic oil.
3. Reinstall the drain plug to the oil tank.
4. Open the tank cap (Figure 34) and fill tank with hydraulic oil. (Capacity: About 4.5 gallons). Use **ShellTellus Oil #46** or equivalent.

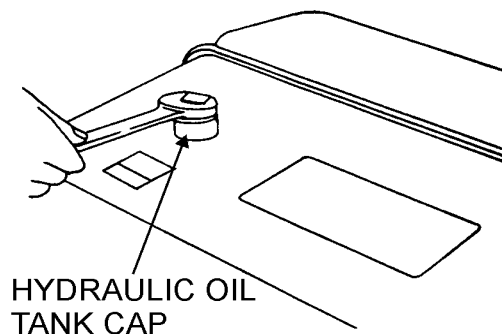

Figure 34. Hydraulic Oil Change

5. After filling tank, tighten the tank cap firmly with a wrench.

## CAUTION:



Make sure that dust , water, and other foreign objects do not enter tank. It is recommended to filter the oil through a cloth.

## HYDRAULIC OIL FILTER CHECK

1. The hydraulic oil filter should be replaced after first 25 hours of operation.
2. After first replacement, it should be replaced after 250 hours operation (2 months), every 500 hours of operation (4 months), and every 1,000 hours of operation thereafter.
3. When the suction resistance exceeds 254mmHg (oil temperature in operation is 140 degrees F), replace filter.
4. To remove the oil filter, wind a cloth around the filter to prevent slipping (Figure 35).
5. Tie a rope securely around the filter (Figure 35).

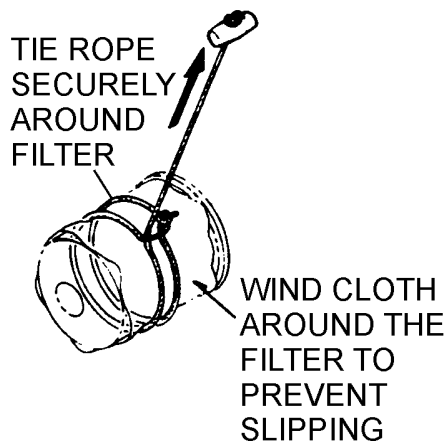

**Figure 35. Cloth and Rope Around Filter**

6. Forcibly pull the rope to remove the filter (Figure 36).

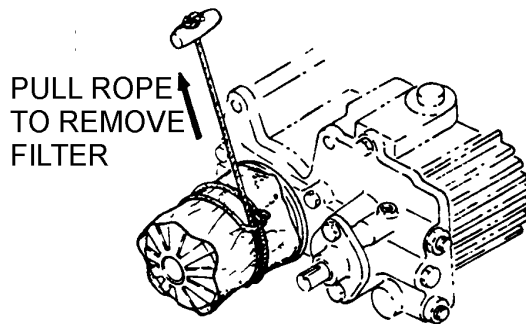

**Figure 36. Filter Removal**

7. Immediately replace with new filter, screwing it on by hand to avoid hydraulic oil leak.

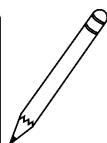
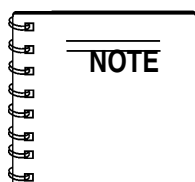

Use only genuine Mikasa replacement oil filters (10 micron filter paper). Do not use automobile-type oil filters.

## HYDRAULIC AIR EXTRACTION

1. After filling hydraulic oil tank with oil, loosen the oil hose joint and check that oil is enough to reach the oil suction and outlet ports in the hydraulic transmission. Tighten the hose joint securely after checking.
2. Loosen the charge relief valve located on the front side of the hydraulic transmission (Figure 37).

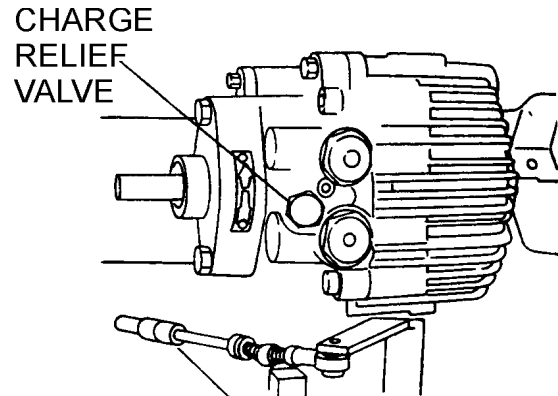

**Figure 37. Loosening Charge Relief Valve**

3. Check that oil flows out from the valve hole.
4. Replace the charge relief valve tightly.
5. With the travel and vibrator levers in neutral position, start the engine and idle at low speed for 3 to 5 minutes.
6. Check the forward and reverse rotation of the output shaft by moving the travel lever slowly to its forward and reverse positions.
7. Check the oil level gauge and make sure that there are no air bubbles mixed in the oil. After checking, operate the roller slowly at first then at full speed.
8. When oil level in the tank is low, replenish oil up to the specified level, and screw the cap securely with a wrench.
9. If bubbles remain in the oil or foam is found, air is being sucked through the suction side and should be checked.

## NEUTRAL POSITION ADJUSTMENT

Once the travel lever has been set to neutral position with the engine running, the hydraulic brake is operating and the roller should not move. If the roller inches forward or backwards with the lever in the neutral position, turn-buckle of the cable should be adjusted as follows:

1. Stop the engine and set the travel lever in the neutral position.
2. Unscrew the two lock nuts on the sides of the cable (Figures 38 and 39).

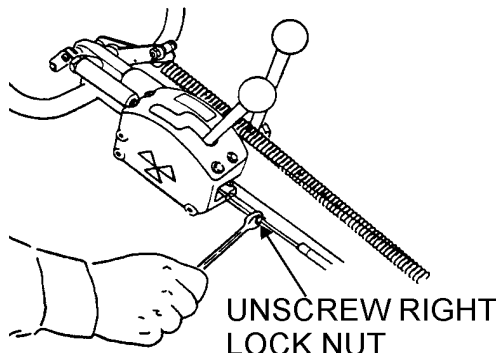

**Figure 38. Unscrewing Right Lock Nut**

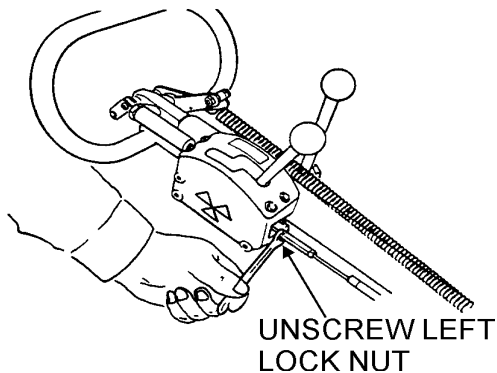

**Figure 39. Unscrewing Left Lock Nut**

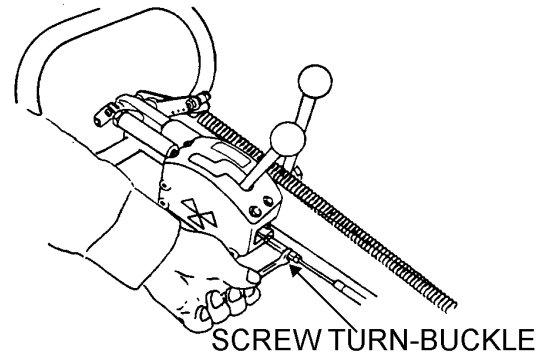

**Figure 40. Adjusting the Turn-Buckle**

If the neutral position of the travel lever and the neutral point of transmission do not match after adjustment is repeated, align as follows:

1. Loosen the hex socket head bolt used for mounting the control lever on the underside of the transmission (Figure 41).
2. For forward movement, move the control lever slightly to the left.
3. for backwards movement, move the control lever slightly to the right.

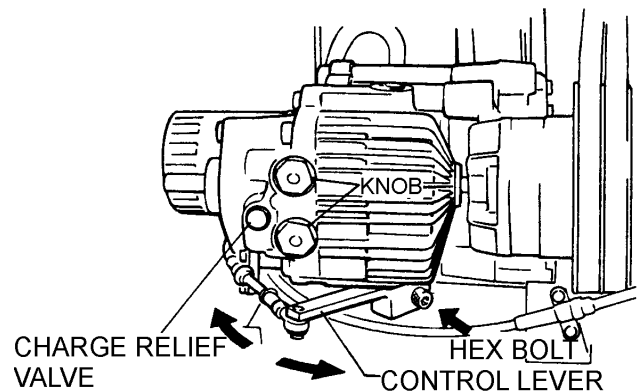

**Figure 41. Unscrewing Left Lock Nut**

3. If the machine moves forward, screw the turn-buckle clockwise. If the machine moves backwards, screw the turn-buckle counterclockwise (Figure 40).
4. Screw back the lock nuts on the turn-buckle.
5. Start the engine and make sure that the roller does not inch forward or backward at the neutral position of the travel lever.

# MDR-9D — TROUBLESHOOTING

Practically all breakdowns can be prevented by proper handling and maintenance inspections, but in the event of a breakdown, please take a remedial action following the diagnosis based on the Engine and Roller Troubleshooting (Tables 8 and 9) information shown below and on the proceeding page. If the problem cannot be remedied, please leave the unit just as it is and consult our company's business office or service plant.

**TABLE 8. ENGINE TROUBLESHOOTING**

SYMPTOM	POSSIBLE PROBLEM	SOLUTION
Engine will not start or start is delayed, although engine can be turned over.	Speed control lever is in "STOP" position?	Set speed control lever to "START" position.
	No fuel reaching injection pump?	Add fuel. Check entire fuel system.
	Defective fuel pump?	Replace fuel pump.
	Fuel filter clogged?	Replace fuel filter and clean tank.
	Faulty fuel supply line?	Replace or repair fuel line.
	Compression too low?	Check piston, cylinder and valves. Adjust or repair per engine repair manual.
	Fuel injector not working correctly?	Repair or replace injector in accordance with engine repair manual.
	Oil pressure too low?	Check engine oil pressure.
	Low starting temperature limit exceeded?	Comply with cold starting instructions and proper oil viscosity.
At low temperatures engine will not start.	Fuel separates has inadequate resistance to low temperatures?	Check whether clear (not turbid) fuel emerges from the fuel line (detach from injection pump). If the fuel is turbid or separated, warm up the engine or drain the complete fuel supply system. Refuel with winter grade diesel fuel.
	Engine oil too thick?	Refill engine crankcase with correct type of oil for winter environment.
Engine fires but stops soon as starter is switched off.	Throttle lever in STOP position?	Reposition throttle lever to RUN position.
	Fuel filter blocked?	Replace fuel filter.
	Fuel supply blocked?	Check the entire fuel system.
Engine stops by itself during normal operation.	Fuel tank empty?	Add fuel.
	Fuel filter blocked?	Replace fuel filter.
Low engine power, output and speed.	Fuel tank empty?	Replace fuel filter.
	Fuel filter clogged?	Replace fuel filter.
	Fuel tank venting is inadequate?	Ensure that tank is adequately vented.
	Speed control lever does not remain in selected position?	See engine manual for corrective action.
	Engine oil level too full?	Correct engine oil level.
Low engine power output and low speed, black exhaust smoke.	Air filter blocked?	Clean or replace air filter.
	Incorrect valve clearances?	Adjust valves per engine specification.
	Malfunction at injector?	See engine manual.

# MDR-9D — TROUBLESHOOTING

**TABLE 8. ENGINE TROUBLESHOOTING (CONTINUED)**

SYMPTOM	POSSIBLE PROBLEM	SOLUTION
Low engine power, output and speed.	Fuel tank empty?	Replace fuel filter.
	Fuel filter clogged?	Replace fuel filter.
	Fuel tank venting is inadequate?	Ensure that tank is adequately vented.
	Speed control lever does not remain in selected position?	See engine manual for corrective action.
	Engine oil level too full?	Correct engine oil level?
Low engine power output and low speed, black exhaust smoke.	Air filter blocked?	Clean or replace air filter.
	Incorrect valve clearances?	Adjust valves per engine specification.
	Malfunction at injector?	See engine manual.

**TABLE 9. ROLLER TROUBLESHOOTING**

SYMPTOM	POSSIBLE PROBLEM	SOLUTION
Unit does not travel or travel is not smooth.	Defective centrifugal clutch?	Repair or replace clutch.
	Damaged rubber coupling and flange?	Replace rubber coupling and flange.
	Defective travel cable and link?	Repair or replacetravel cable and link.
	Damaged scraper or too much mud in scraper?	Replace or repair scraper.
	Damaged or clogged oil filter?	Replace filter.
	Damaged or leaking hydraulic pipe?	Repair or replace parts.
	Low oil level or contaminated oil?	Replenish or replace oil.
	Damaged or leaking hydraulic transmission?	Repair or replace hydraulic pump.
	Damaged or leaking hydraulic transmission?	Repair or replace hydraulic motor.
	Damaged drum gear and bearing?	Repair parts.
	Bad drum rotation?	Repair or replace drum.
Unit does not vibrate or has weak vibration.	Defective centrifugal clutch?	Repair or replace clutch.
	Damaged or slipping V-belt?	Replace V-belt or adjust tension.
	Damaged vibration cable and linkage?	Replace or repair vibration cable and linkage.
	Damaged vibration clutch?	Adjust or replace clutch.
	Defective clutch vibrator pulley V-belt?	Replace V-belt.
	Vibrator does not turn smoothly with hand?	Check and repair vibrator. Check if oil level is not excessively high.

# EXPLANATION OF CODE IN REMARKS COLUMN

How to read the marks and remarks used in this parts book.

## Items Found In the “Remarks” Column

Serial Numbers-Where indicated, this indicates a serial number range (inclusive) where a particular part is used.

Model Number-Where indicated, this shows that the corresponding part is utilized only with this specific model number or model number variant.

## Items Found In the “Items Number” Column

All parts with same symbol in the number column, \*, #, +, %, or <, belong to the same assembly or kit

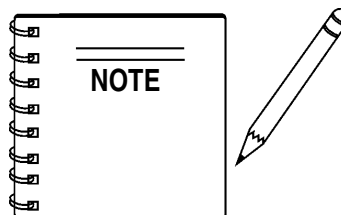

If more than one of the same reference number is listed, the last one listed indicates newest (or latest) part available.

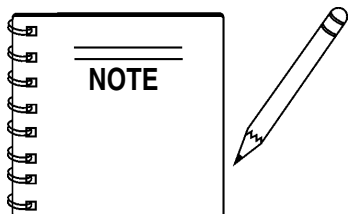

The contents of this parts catalog are subject to change without notice.



MQ MIKASA MDR-9D/MDR-9DES VIBRATORY WALK-BEHIND ROLLER W/HATZ 1D81Z DIESEL ENGINE

## ***1 to 3 Units***

<u>Qty.</u>	<u>P/N</u>	<u>Description</u>
3 .....	501010440 .....	OIL FILTER, TRANSMISSION
1 .....	075080061 .....	CHAIN, DRIVE
6 .....	EM505834 .....	V-BELT
3 .....	502303040 .....	THROTTLE WIRE
6 .....	01480000 .....	OIL FILTER, ENGINE
6 .....	50478800 .....	FUEL FILTER, ENGINE
6 .....	01493000 .....	AIR FILTER, ENGINE
3 .....	50345300 .....	KEY, IGNITION

# MDR-9D — DECAL PLACEMENT

## DECAL PLACEMENT

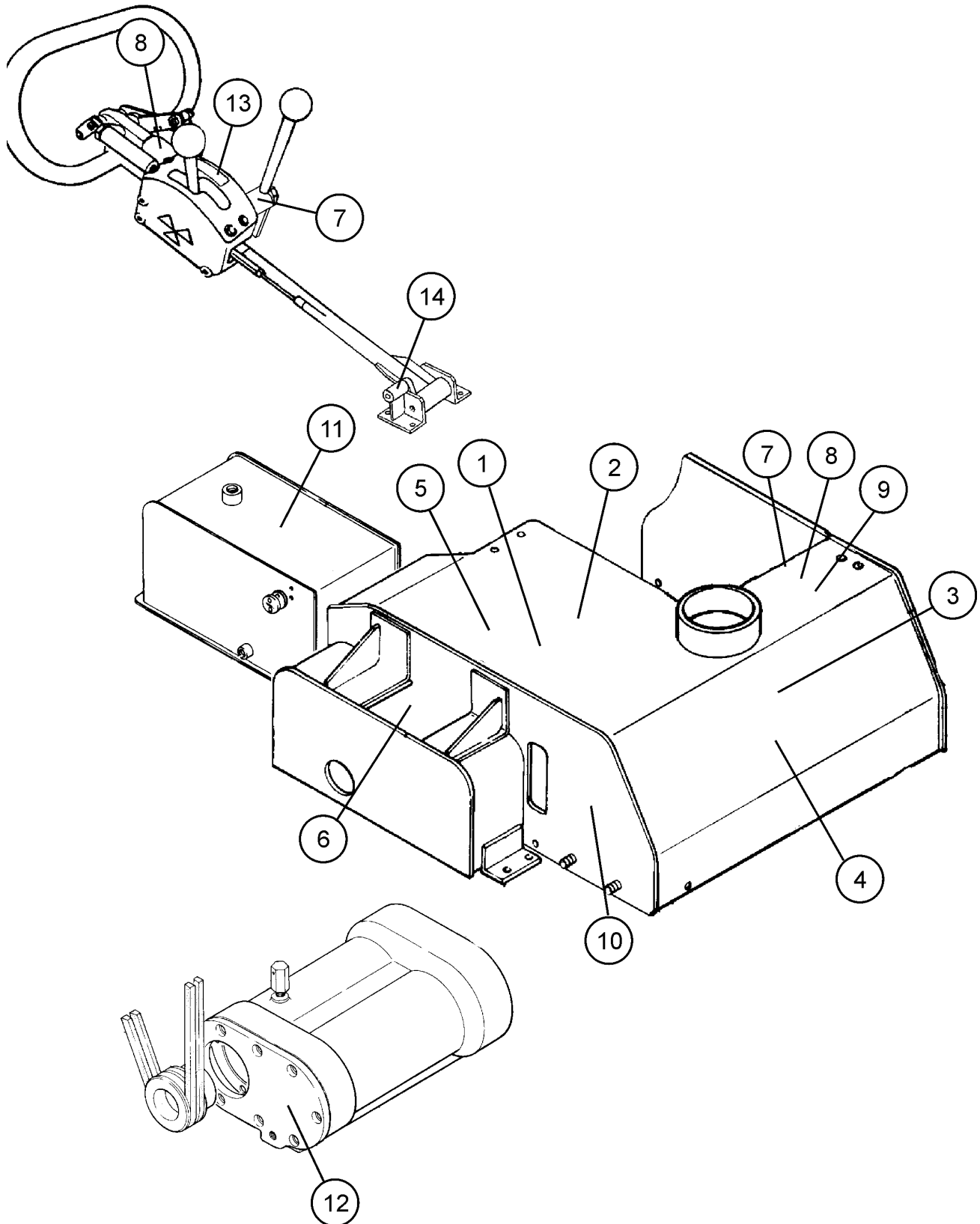

## DECAL PLACEMENT

<u>NO.</u>	<u>PART NO.</u>	<u>PART NAME</u>	<u>QTY.</u>	<u>REMARKS</u>
1	920200591	PLATE, CAUTION	1	
2	920200630	PLATE, SERIAL NO.	1	
3	920201590	DECAL, MQ MARK 98X70	1	
4	920101510	DECAL, MIKASA MARK 440MM	1	
5	920203290	DECAL, CAUTION	1	
6	920200450	DECAL, OIL FILTER	1	
7	920101290	DECAL, VIBRATION	2	
8	920201100	DECAL, CLUTCH LEVER	2	
9	920200320	DECAL, WATER TANK	1	
10	920200440	DECAL, PROHIBIT TOW	1	
11	920200470	DECAL, OIL TANK	1	
12	920101480	DECAL, OIL LEVEL	1	
13	920101280	DECAL, FORWARD & REVERSE	1	
14	920101200	DECAL, GREASE	1	

# MDR-9D — BODY ASSY.

BODY ASSY.

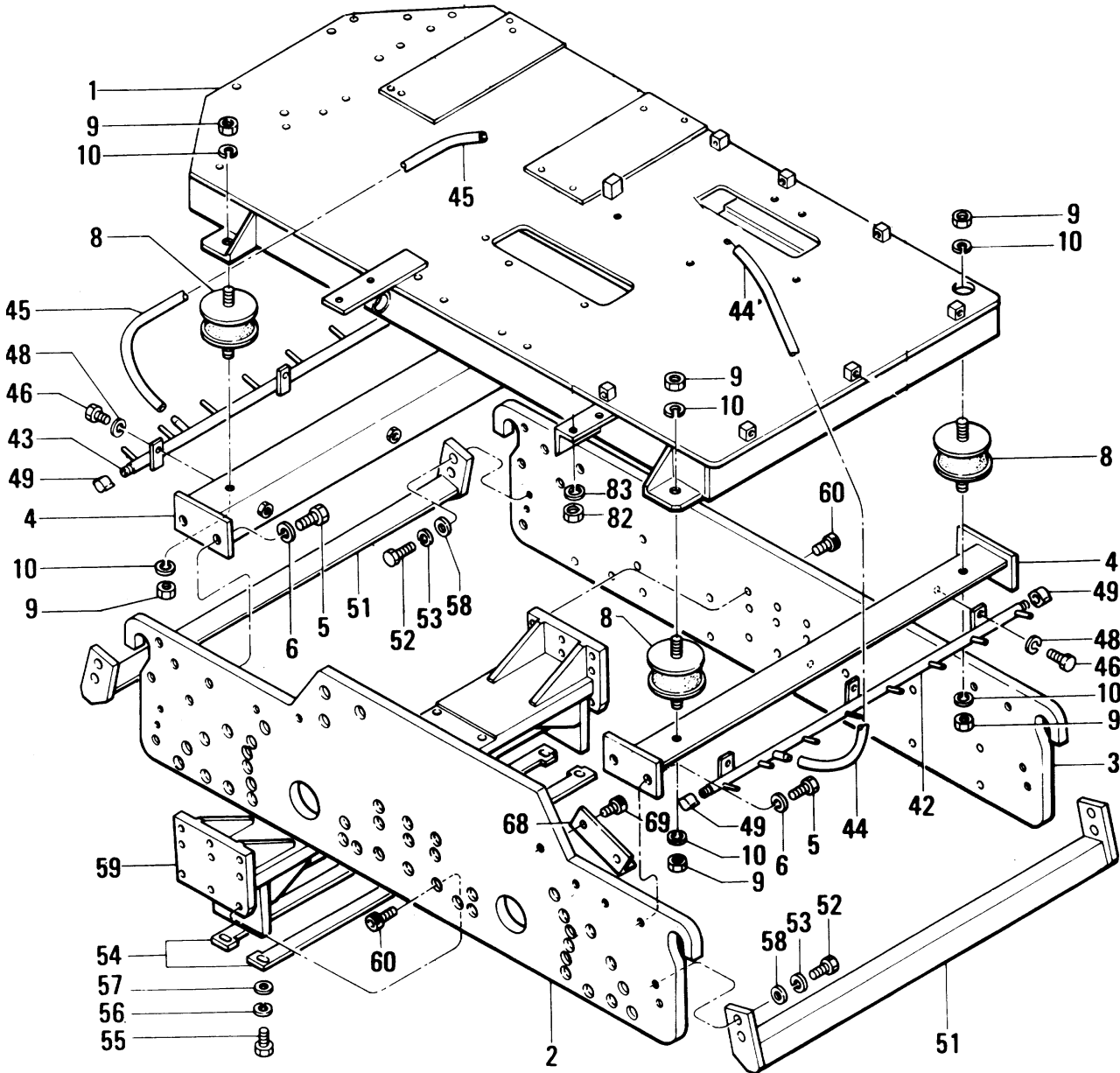

BODY ASSY.

<u>NO.</u>	<u>PART NO.</u>	<u>PART NAME</u>	<u>QTY.</u>	<u>REMARKS</u>
1	502100600	BASE	1	
2	502100720	SIDE PLATE, RIGHT	1	
3	502100710	SIDE PLATE, LEFT	1	
4	502200960	RUBBER PLATE	2	
5	001211430	BOLT 14X30 H	8	
6	030214350	WASHER, LOCK	8	
8	930407021	SHOCK ABSORBER MED-70/MS	4	
9	020312100	NUT	8	
10	030212300	WASHER, LOCK	8	
42	502201150	SPRINKLING PIPE, FRONT	1	
43	502201160	SPRINKLING PIPE, REAR	1	
44	502402930	VINYL PIPE 10X13X280	1	
45	502402940	VINYL PIPE 10X13X950	1	
46	001221025	BOLT 10X25 T	6	
48	030210250	WASHER, LOCK	6	
49	501010150	CAP 1/4	4	
51	502302511	SCRAPER, END	2	
52	001221030	BOLT 10X30 T	8	
53	030210250	WASHER, LOCK	8	
54	502424050	SCRAPER/CENTER	2	
55	001220825	BOLT 8X25 T	6	
56	030208200	WASHER, LOCK	6	
57	952401560	WASHER 8.5X20X3	6	
58	031110160	WASHER, FLAT	8	
59	502200990	BASE, SCRAPER	1	
60	001521225	SOCKET HEAD BOLT 12X25 T	18	
68	502403940	CHAIN COVER	2	
69	001521020	SOCKET HEAD BOLT 10X20 T	4	
82	020310080	NUT	4	
83	030210250	WASHER, LOCK	4	

# MDR-9D — FRONT COVER ASSY.

## FRONT COVER ASSY.

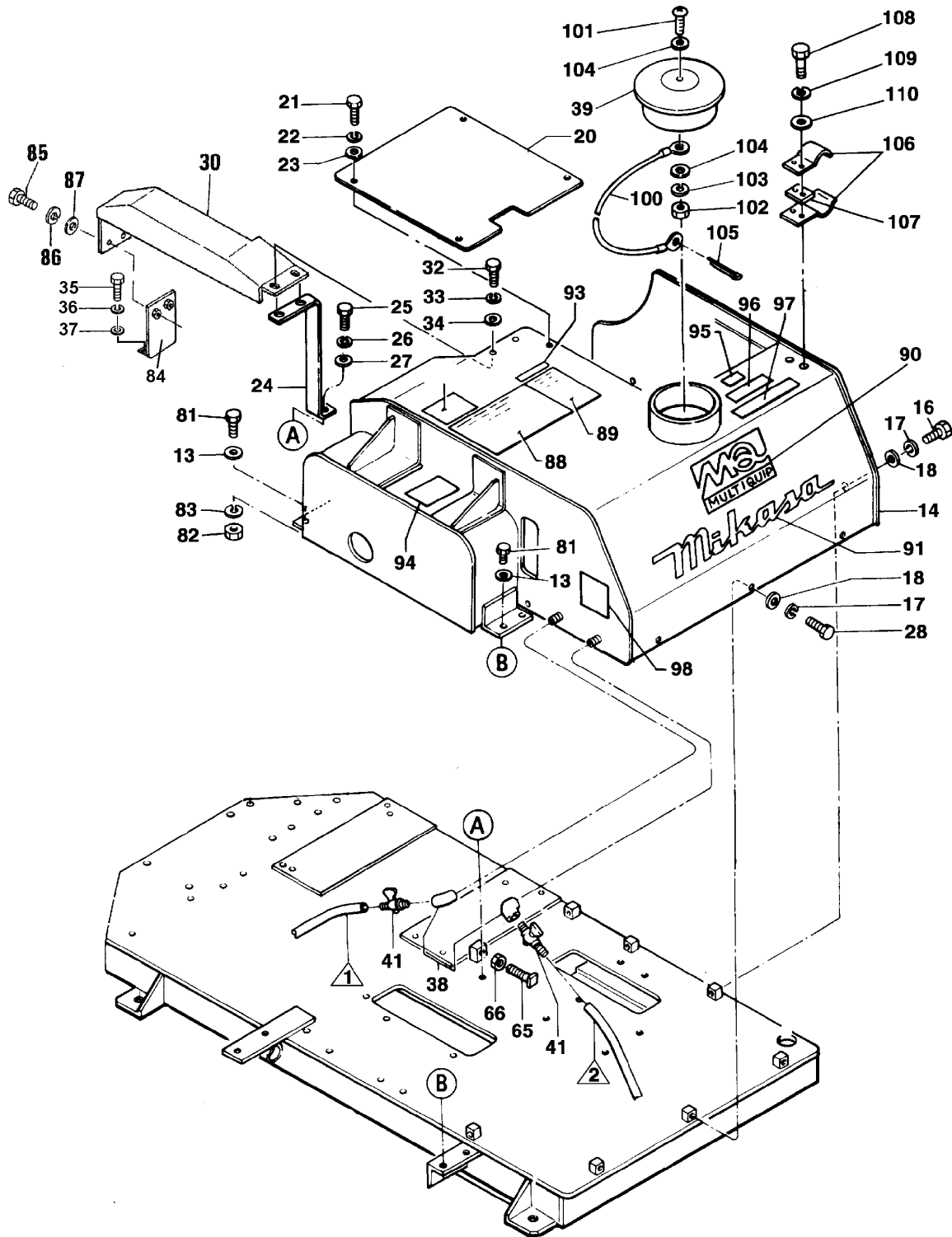

### NOTES:

- ① BODY ASSY., ITEM 44
- ② BODY ASSY., ITEM 45

# MDR-9D — FRONT COVER ASSY.

## FRONT COVER ASSY.

<u>NO.</u>	<u>PART NO.</u>	<u>PART NAME</u>	<u>QTY.</u>	<u>REMARKS</u>
13	031110160	WASHER, FLAT	4	
14	502103800	FRONT COVER	1	
16	001220820	BOLT 8X20 T	4	
17	030208200	WASHER, LOCK	7	
18	952401560	WASHER 8.5X20X3	7	
20	502302490	CHECK COVER	1	
21	001220815	BOLT 8X15 T	4	
22	030208200	WASHER, LOCK	4	
23	031108160	WASHER, FLAT	4	
24	502302500	SUPPORT/COVER	1	
25	001221020	BOLT 10X20 T	1	
26	030210250	WASHER, LOCK	1	
27	021110160	WASHER, FLAT	1	
28	001220825	BOLT 8X25 T	3	
30	502201830	BELT COVER	1	
32	001221020	BOLT 10X20 T	2	
33	030210250	WASHER, LOCK	2	
34	031110160	WASHER, FLAT	2	
35	001221015	BOLT 10X15 T	2	
36	030210250	WASHER, LOCK	2	
37	031110160	WASHER, FLAT	2	
38	502010650	ELBOW 90 DEG. 1/4	2	
39	407310670	TANK CAP D108-120, RUBBER	1	
41	954403241	COCK PT 1/4, BH-1211 (AL)	2	
65	001801050	BOLT 10X50 WHOLE THREAD	1	
66	020310080	NUT		
81	001211030	BOLT 10X30 H	4	
82	020310080	NUT	4	
83	030210250	WASHER, LOCK	4	
84	502405920	PLATE, COVER SETTING	1	
85	001221020	BOLT 10X20 T	2	
86	030210250	WASHER, LOCK M10	2	
87	031110160	WASHER, FLAT M10	2	
100	959402990	ROPE	1	
101	091005020	SCREW 5X20	1	
102	020305040	NUT	1	
103	030205130	WASHER, LOCK	1	
104	031105080	WASHER, FLAT	2	
105	025203020	SPLIT COTTER PIN 3X20	1	
106	959403251	PLATE SPRING	2	
107	502420150	SPACER	1	
108	001200820	BOLT 8X20	2	
109	030208200	WASHER, LOCK	2	
110	031108160	WASHER, FLAT	2	

# MDR-9D — AXLE ASSY.

AXLE ASSY.

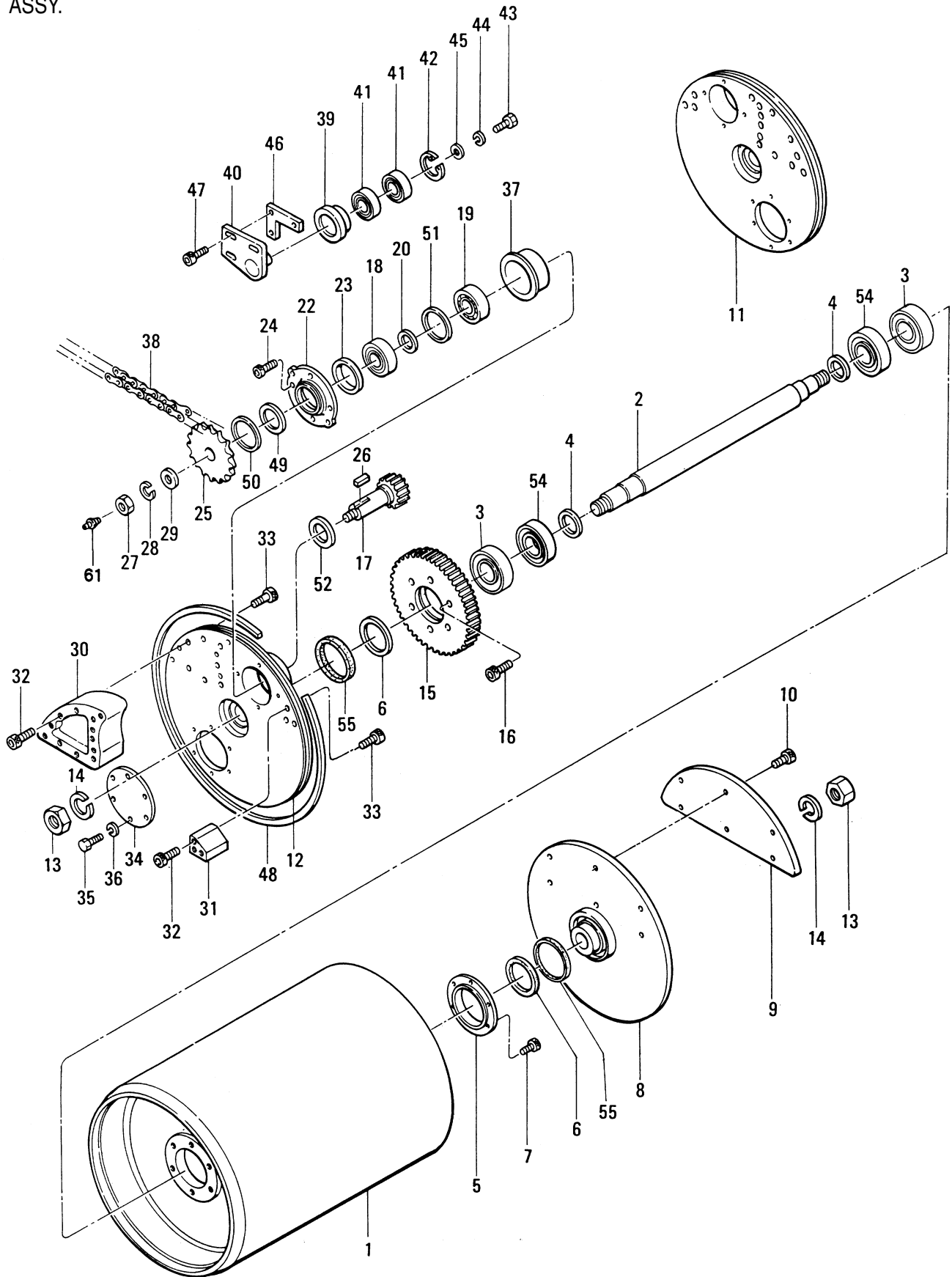



## AXLE ASSY.

<u>NO.</u>	<u>PART NO.</u>	<u>PART NAME</u>	<u>QTY.</u>	<u>REMARKS</u>
1	502101570	DRUM	2	
2	502202290	ROLLER SHAFT	2	
3	044006309	BEARING 6309VV	4	
4	952400940	SPACER 45605	4	
5	502302420	BEARING COVER	2	
6	060406010	OIL SEAL TC-689012	4	
7	001521025	SOCKET HEAD BOLT 10X25 T	12	
8	502200930	BRACKET/L	2	
9	502302430	SPACER	2	
10	001521240	SOCKET HEAD BOLT 12X40 T	12	
11	502200940	BRACKET/R FRONT	1	
12	502200950	BRACKET/R REAR	1	
13	020130240	NUT M30, P2.0	4	
14	030230750	WASHER, LOCK M30	4	
15	502302440	GEAR 57	2	
16	001521040	SOCKET HEAD BOLT 10X40 T	12	
17	502303370	GEAR SHAFT	2	
17	502338050	GEAR SHAFT	2	
18	044006370	BEARING 6307VV	2	
19	047910050	ROLLER BEARING NF307W	2	
20	952401240	SPACER 35453	2	
20	952406190	SPACER 35X45X3 S	2	
22	502302460	COVER/GEAR SHAFT	2	
23	060305010	OIL SEAL TB-55729	2	
24	001520820	SOCKET HEAD BOLT 8X20 T	8	
25	502402720	SPROCKET 15	2	
26	951400090	KEY 10X8X33	2	
27	020118150	NUT M18, P1.5	2	
28	030218460	WASHER, LOCK M18	2	
29	952400950	WASHER 19456	2	
30	502305360	BLOCK	2	
31	502303590	CYLINDER BLOCK	2	
32	001521235	SOCKET HEAD BOLT 12X35 T	30	
33	001521240	SOCKET HEAD BOLT 12X40 T	30	
34	502402740	BRACKET COVER	2	
35	001210820	BOLT 8X20 H	12	
36	030208200	WASHER, LOCK	12	
37	502403090	BEARING HOLDER	2	
38	075080061	CHAIN RS80-61	1	
39	502402920	TIGHTENER	1	

# MDR-9D — AXLE ASSY. (CONTINUED)

AXLE ASSY.

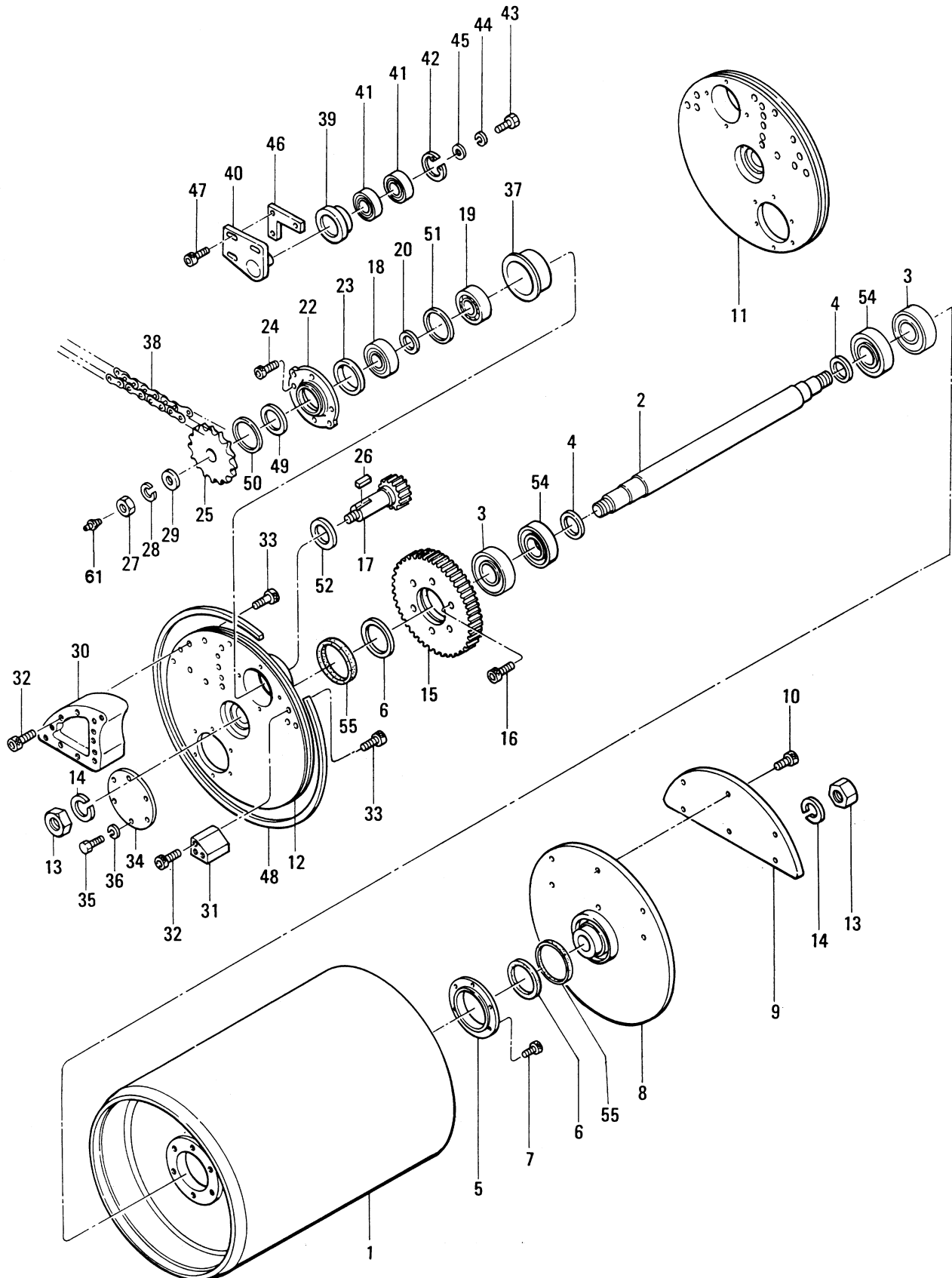

## MDR-9D — AXLE ASSY. (CONTINUED)

### AXLE ASSY.

<u>NO.</u>	<u>PART NO.</u>	<u>PART NAME</u>	<u>QTY.</u>	<u>REMARKS</u>
40	502302480	TIGHTENER PLATE (SHAFT)	1	
41	044006205	BEARING 6205VV	2	
42	080100520	STOP RING R-52	1	
43	001210820	BOLT 8X20 H	1	
44	030208200	WASHER, LOCK	1	
45	952400130	WASHER 9304	1	
46	502402750	TIGHTENER PLATE HOLDER	1	
47	001521230	SOCKET HEAD BOLT 12X30 T	3	
48	502402760	FELT SEAL 6X8X1350	2	
49	502402770	FELT SEAL 6X8X188	2	
50	502402780	FELT SEAL 5X6X217	2	
51	952401330	COLLAR 72803	2	
52	060604030	OIL SEAL VC-45686	2	
54	042006309	BEARING 6309ZZ	4	
55	502408150	FELT RING 901027	4	
61	351010050	GREASE FITTING A-MT6X1	2	

# MDR-9D — TRANSMISSION ASSY.

TRANSMISSION ASSY.

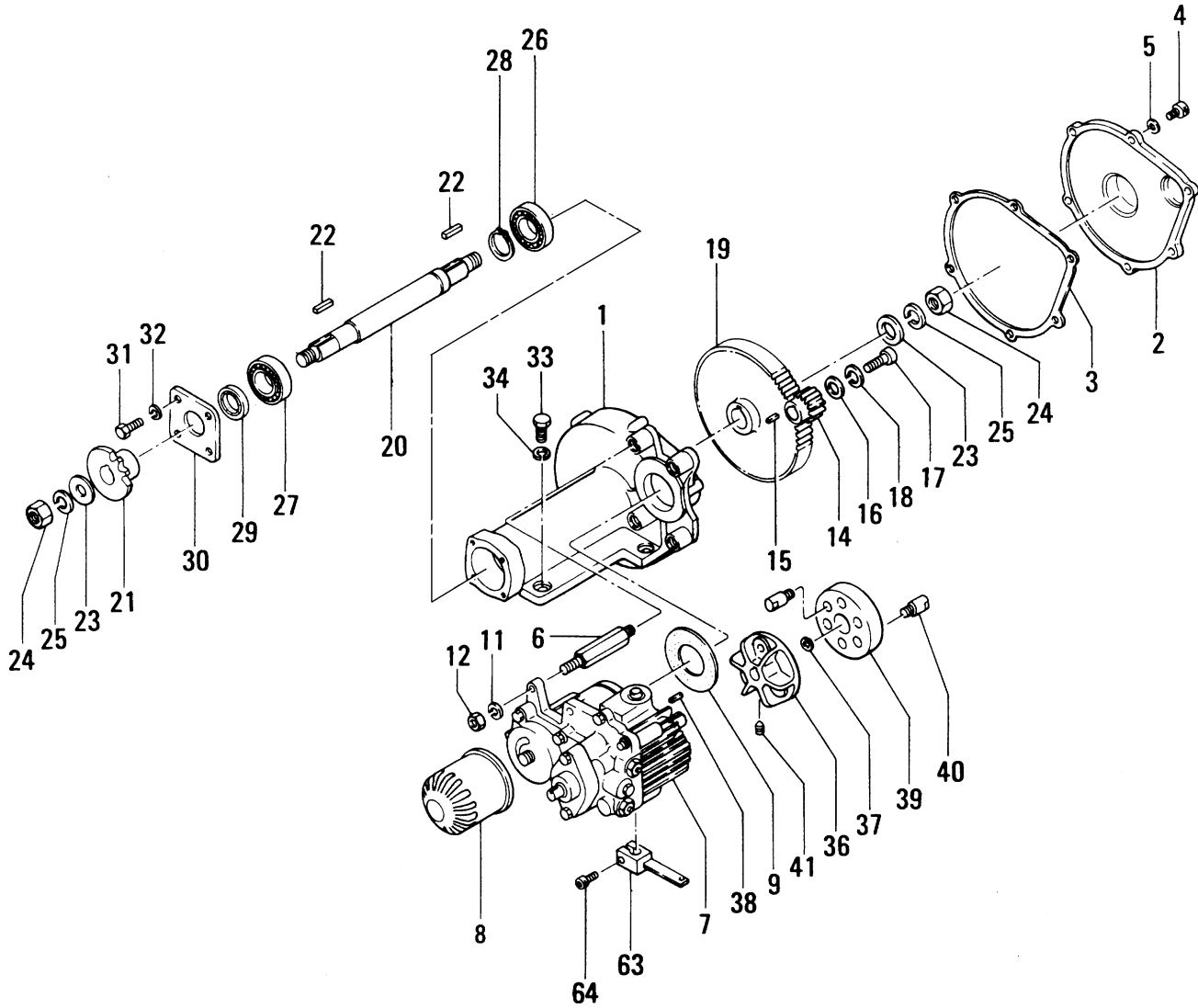

# MDR-9D — TRANSMISSION ASSY.

## TRANSMISSION ASSY.

<u>NO.</u>	<u>PART NO.</u>	<u>PART NAME</u>	<u>QTY.</u>	<u>REMARKS</u>
1	502010530	GEAR CASE	1	
2	502010540	COVER, GEAR CASE	1	
3	501010410	PACKING, GEAR CASE COVER	1	
4	001520620	SOCKET HEAD BOLT 6X20 T	6	
5	031106100	WASHER, FLAT M6	6	
6	501010420	SET BOLT, 87L-M12-/HST	4	
7	501010430	TRANSMISSION 1515-522	1	
8	501010440	OIL FILTER	1	
9	501010450	PACKING/TRANSMISSION	1	
11	030210250	WASHER, LOCK	4	
12	020310080	NUT	4	
14	501010460	PINION 15	1	
15	951400100	KEY 5X5X35	1	
16	952400130	WASHER 9304	1	
17	001210820	BOLT 8X20 H	1	
18	030208200	WASHER, LOCK	1	
19	502303350	GEAR 80	1	
20	502010570	DRIVE SHAFT	1	
21	501010500	SPROKET 9	1	
22	951400110	KEY 7X7X35	2	
23	952400170	WASHER 19454	2	
24	020118150	NUT M18, P1.5	2	
25	030218460	WASHER, LOCK M18	2	
26	042006207	BEARING 6207ZZ	1	
27	042006306	BEARING 6306ZZ	1	
28	080200350	STOP RING S-35	1	
29	060303030	OIL SEAL TB-30428	1	
30	501010520	BEARING COVER	1	
31	001220825	BOLT 8X25 T	4	
32	030208200	WASHER, LOCK	4	
33	001211025	BOLT 10X25 H	4	
34	030210250	WASHER, LOCK	4	
36	502302530	FLANGE FAN	1	
37	080100160	STOP RING R-16	1	
38	502010590	KEY 5X5X22/4DK	1	
39	502321570	RUBBER COUPLING	1	
40	515447020	COUPLING PIN	6	
41	099208012	SOCKET HEAD SCREW 8X12 T	2	
63	502402800	LEVER	1	
64	001521025	SOCKET HEAD BOLT 10X25 T	1	

# MDR-9D — HYDRAULIC OIL TANK ASSY.

HYDRAULIC OIL TANK ASSY.

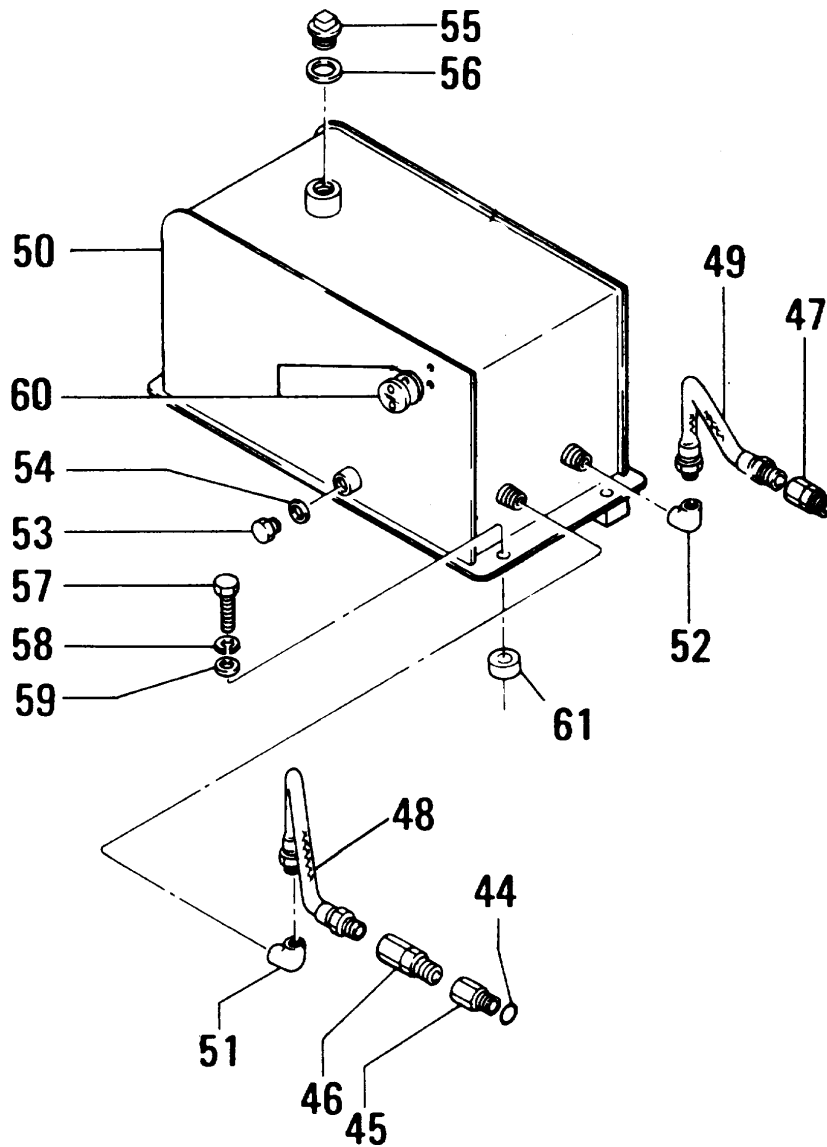

## MDR-9D — HYDRAULIC OIL TANK ASSY.

### HYDRAULIC OIL TANK ASSY.

<u>NO.</u>	<u>PART NO.</u>	<u>PART NAME</u>	<u>QTY.</u>	<u>REMARKS</u>
44	050200160	O-RING P-16	1	
45	501010720	JOINT 3/4-16	1	
46	501010590	JOINT 3/8	1	
47	501010600	JOINT 1/4	1	
48	502302850	OIL HOSE 3/8 320L	1	
49	502302840	OIL HOSE 1/4 320L	1	
50	502201000	OIL TANK	1	
51	502010640	ELBOW 90 DEG. 3/8	1	
52	502010650	ELBOW 90 DEG. 1/4	1	
53	953405270	PLUG 1/4X14 13L	1	
54	953405260	PACKING 1/4 (CU)	1	
55	953405840	DRAIN PLUG M18 (H)	1	
56	953400020	PACKING 19302	1	
57	001221035	BOLT 10X35 T	4	
58	030210250	WASHER, LOCK	4	
59	031110160	WASHER, FLAT	4	
60	959010110	LEVEL GAUGE/SP-1 W/P	1	
61	952401960	COLLAR 11X30X16	1	

# MDR-9D — CLUTCH BOX ASSY.

## CLUTCH BOX ASSY.

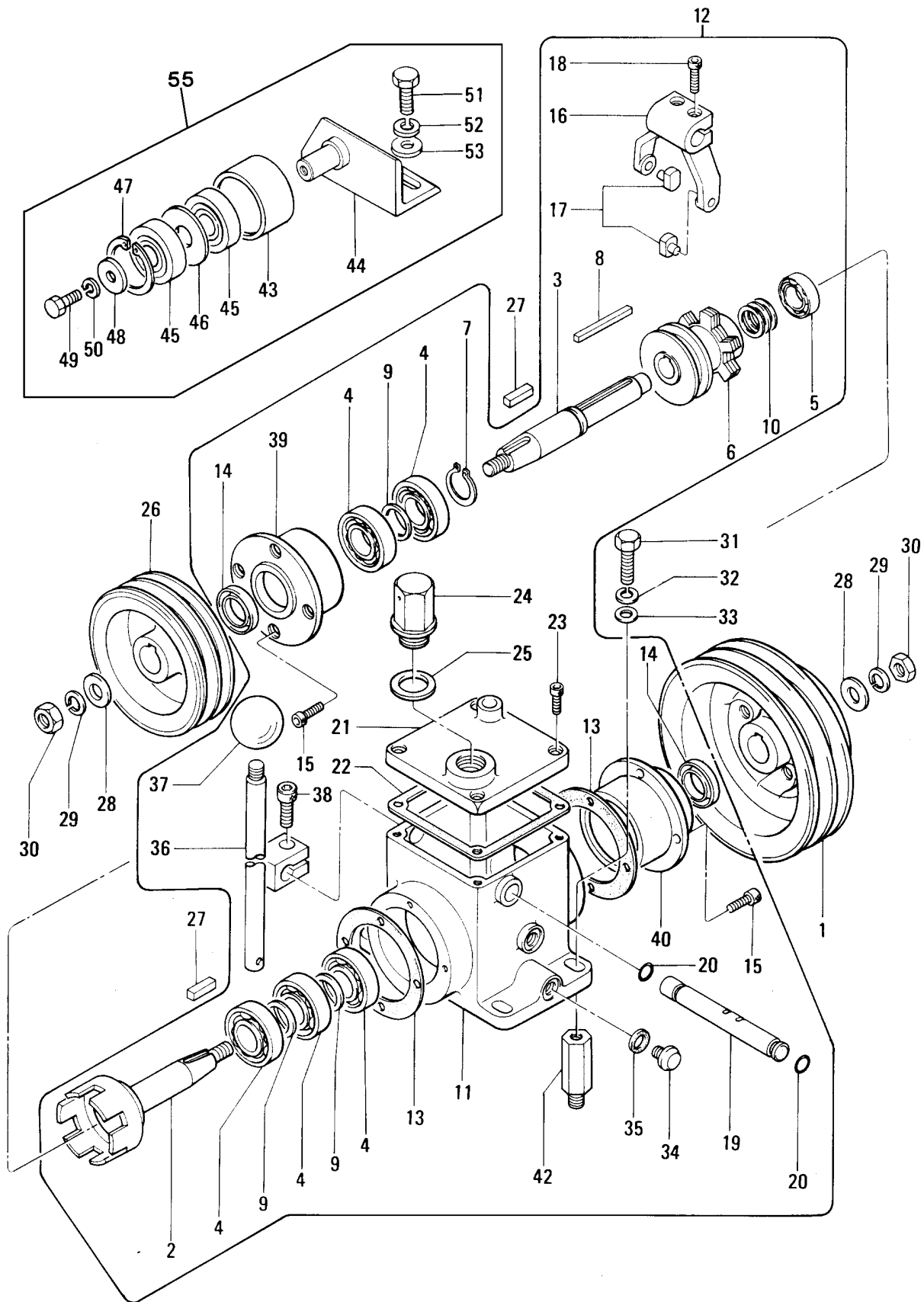



# MDR-9D — CLUTCH BOX ASSY.

## CLUTCH BOX ASSY.

<u>NO.</u>	<u>PART NO.</u>	<u>PART NAME</u>	<u>QTY.</u>	<u>REMARKS</u>
1	502302610	CLUTCH PULLEY/IN	1	
2*	502302620	CLUTCH SHAFT/IN	1	
3*	502302630	CLUTCH SHAFT/OUT	1	
4*	040006205	BEARING 6205	5	
5*	040006202	BEARING 6202	1	
6*	501010800	CLUTCH SL1.2-20/OS225	1	
7*	080200250	STOP RING S-25	1	
8*	951400060	KEY 5X5X58	1	
9*	501010810	COLLAR 25322/BEARING	3	
10*	501010822	SPACER 0.8T/CLUTCH	AR	
10*	501010823	SPACER 1.0T/CLUTCH	AR	
10*	501010824	SPACER 2.3T/CLUTCH	AR	
10*	501010825	SPACER 3.2T/CLUTCH	AR	
11*	501010830	CLUTCH CASE	1	
12*	502910010	CLUTCH BOX ASSY. ....	1	..... INCLUDES ITEMS W/*
13*	501010830	PACKING/BEARING HOLDER	2	
14*	060102010	OIL SEAL SB-25388	2	
15*	001520620	SOCKET HEAD BOLT 6X20 T	8	
16*	501010850	SHIFTER FORK	1	
17*	501010860	FORK BLOCK	2	
18*	001520625	SOCKET HEAD BOLT 6X25 T	2	
19*	501010870	SHIFTER SHAFT	1	
20*	050200110	O-RING P-11	2	
21*	501301160	COVER, CLUTCH CASE	1	
22	501010890	PACKING, CLUTCH CASE	1	
23*	001520625	SOCKET HEAD BOLT 6X25 T	4	
24*	501010900	PLUG 3/4	1	
25*	501010910	PACKING 3/4	1	
26	502302640	CLUTCH PULLEY/OUT	1	
27	951400070	KEY 7X7X26	2	
28	952400140	WASHER 13304	2	
29	030212300	WASHER, LOCK M12	2	
30	020312100	NUT	2	
31	001221035	BOLT 10X35 T	4	
32	030210250	WASHER, LOCK	4	
33	952401860	WASHER 112545	4	
34	953400270	PLUG 1/4X14 10L	2	
34	953405270	PLUG 1/4X14 13L	2	

# MDR-9D — CLUTCH BOX ASSY. (CONTINUED)

CLUTCH BOX ASSY.

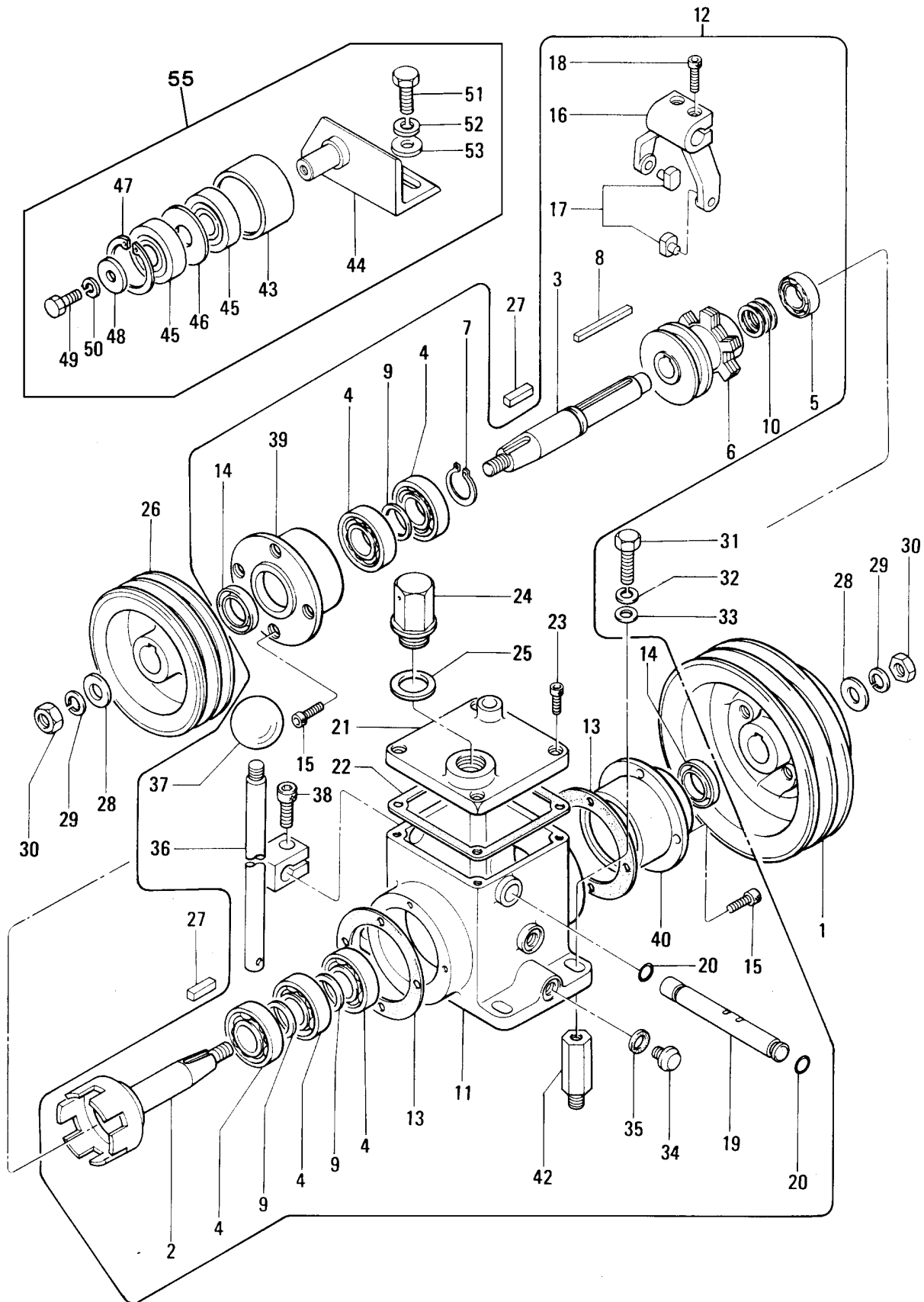

## MDR-9D — CLUTCH BOX ASSY. (CONTINUED)

### CLUTCH BOX ASSY.

<u>NO.</u>	<u>PART NO.</u>	<u>PART NAME</u>	<u>QTY.</u>	<u>REMARKS</u>
35*	953405260	PACKING 1/4 (CU)	2	
36*	502302650	CLUTCH LEVER	1	
37*	959402980	BALL GRIP 40D-M12	1	
38*	001521025	SOCKET HEAD BOLT 10X25 T	1	
39*	501010950	BEARING HOLDER	1	
40*	502302660	BEARING HOLDER/INPUT SIDE	1	
42*	501402260	SET BOLT, L50M12/CLUTCH	4	
43#	501402400	TIGHTENER PULLEY	1	
44#	501302160	TIGHTENER SUPPORT	1	
45#	042006204	BEARING 6204ZZ	2	
46#	952400930	COLLAR 20252	1	
47#	080100470	STOP RING R-47	1	
48#	952400130	WASHER 9304	1	
49#	001200820	BOLT 8X20	1	
50#	030208200	WASHER, LOCK	1	
51#	001221035	BOLT 10X35 T	2	
52#	030210250	WASHER, LOCK	2	
53#	031110160	WASHER, FLAT	2	
55	501910040	BELT TIGHTENER ASSY. ....	1	..... INCLUDES ITEMS W/#

# MDR-9D — VIBRATION CASE ASSY.

VIBRATION CASE ASSY.

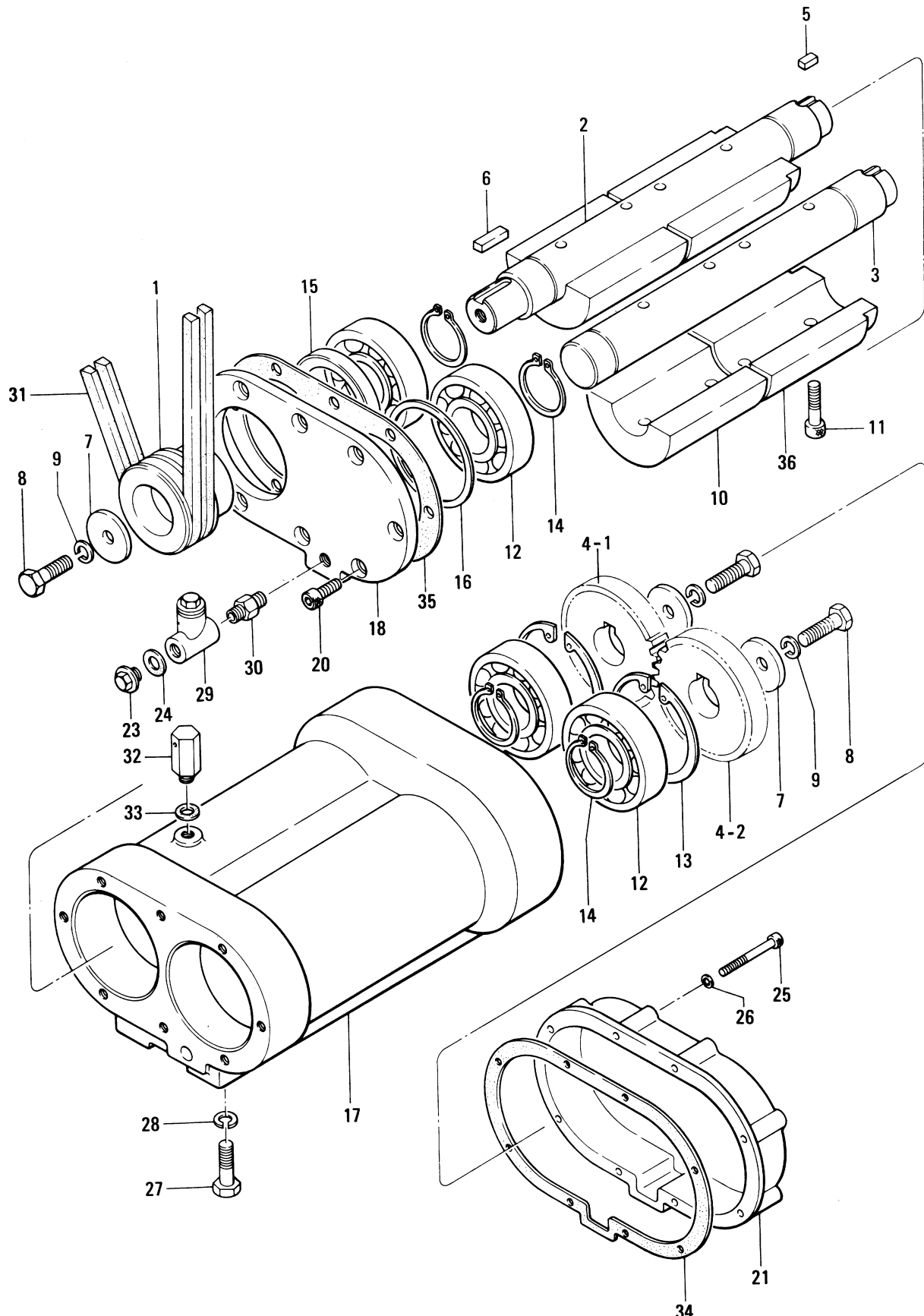

# MDR-9D — VIBRATION CASE ASSY.

## VIBRATION CASE ASSY.

<u>NO.</u>	<u>PART NO.</u>	<u>PART NAME</u>	<u>QTY.</u>	<u>REMARKS</u>
1	502302570	VIBRATING PULLEY	1	
2	502201010	ROTARY SHAFT/L	1	
3	502201020	ROTARY SHAFT/R	1	
4-1	502302582	GEAR (DRIVE-1P)	1	
4-2	502302581	GEAR 44 (DRIVEN-2P)	1	
5	951400081	KEY 10X8X17	2	
6	951400090	KEY 10X8X33	1	
7	952400900	WASHER 13446	3	
8	001211235	BOLT 12X35 H	3	
9	030212300	WASHER, LOCK M12	3	
10	502302590	ECCENTRIC ROTATOR	2	
11	001521040	SOCKET HEAD BOLT 10X40 T	8	
12	040006309	BEARING 6309	4	
13	080101000	STOP RING R-100	2	
14	080200450	STOP RING S-45	4	
15	060106010	OIL SEAL SB-659013	1	
15	060206020	OIL SEAL SC-659013	1	
16	952400911	SPACER 801003	1	
17	502100650	VIBRATING CASE	1	
18	502302600	CASE COVER	1	
20	001521025	SOCKET HEAD BOLT 10X25 T	8	
21	502201030	GEAR COVER	1	
23	953400270	PLUG 1/4X14 10L	2	
23	953405270	PLUG 1/4X14 13L	2	
24	953405260	PACKING 1/4 (CU)	2	
25	001520652	SOCKET HEAD BOLT 6X60 T	8	
26	031106100	WASHER, FLAT M6	8	
27	001221445	BOLT 14X45 T	14	
28	030214350	WASHER, LOCK M14	14	
29	502403140	T-JOINT	1	
30	502010860	NIPPLE PT1/4	1	
31	070100360	V-BELT A-36	2	
32	502402300	BREATHER	1	
33	953405260	PACKING 1/4 (CU)	1	
34	502303010	PACKING, VIBRATION CASE/A	1	
35	502303020	PACKING, VIBRATION CASE/B	1	
36	502305480	ECCENTRIC ROTATOR	2	



## MDR-9D — UPPER CONTROL HANDLE ASSY.

### UPPER CONTROL HANDLE ASSY.

<u>NO.</u>	<u>PART NO.</u>	<u>PART NAME</u>	<u>QTY.</u>	<u>REMARKS</u>
1	502101480	BAR HANDLE, D.C./9D	1	
13	501011090	TRAVELING LEVER	1	
14	501011100	LINK	1	
15	959402980	BALL GRIP 40D-M12	2	
16	001520620	SOCKET HEAD BOLT 6X20 T	1	
17	030206150	WASHER, LOCK M6	15	
18	031106100	WASHER, FLAT M6	6	
19	501011110	STEEL BALL	1	
20	501011120	SPRING, 1.2X8X34	1	
21	505422750	GUIDE	1	
22	001520615	SOCKET HEAD BOLT 6X15 T	2	
23	501011140	BUSH 8918, LINK	1	
24	501011150	CONICAL SPRING WASHER	1	
25	001200835	BOLT 8X35	1	
26	020308060	NUT	1	
27	031108160	WASHER, FLAT	1	
29	501011162	ROD END PR6-209	3	
30	502314420	CABLE ASSY./C2110	1	
31	501011180	CLAMP HC-40	4	
32	501203980	HANDLE, D.C.	1	
34	001210615	BOLT 6X15 H	4	
39	001210620	BOLT 6X20 H	2	
40	501202200	LEVER COVER, D.C.	1	
41	501011220	LEVER GUIDE	1	
42	001520652	SOCKET HEAD BOLT 6X60 T	3	
43	001210615	BOLT 6X15 H	4	
44	031106100	WASHER, FLAT M6	4	
48	501011310	VIBRATING LEVER	1	
49	050200160	O-RING P-16	1	
50	020312100	NUT	1	
51	030212300	WASHER, LOCK M12	1	
52	031112230	WASHER, FLAT M12	1	
53	502314410	CABLE ASSY./C2550	1	
60	001220615	BOLT 6X25 T	4	





## MDR-9D — UPPER CONTROL HANDLE ASSY. (CONTINUED)

### UPPER CONTROL HANDLE ASSY.

<u>NO.</u>	<u>PART NO.</u>	<u>PART NAME</u>	<u>QTY.</u>	<u>REMARKS</u>
61	025202020	SPLIT COTTER PIN 2X20	1	
62	502010930	CLEVIS	1	
63	502010940	CLEVIS PIN	1	
97	501413650	TURN BUCKLE	1	
98	501413660	ADJUST BOLT	1	
99	020306050	NUT M6	1	
100	022910090	NUT M6 (L)	1	
101	501407790	HANDLE PIN, D.C.	1	
102	501305190	ROD, D.C.	1	
103	502416960	ROD-GUIDE	1	
104	001520815	SOCKET HEAD BOLT 8X15 T	2	
105	501407810	ROD SPRING, D.C.	1	
106	501407820	NUT, D.C.	1	
107	501416950	LINK, D.C.	1	
108	099206008	SOCKET HEAD SCREW 6X8 T	1	
109	501407840	LINK PIN, D.C., 6X28-23	1	
110	031106100	WASHER, FLAT M6	2	
111	025202012	SPLIT COTTER PIN 2X12	2	
112	501416970	LEVER, D.C.	1	
113	001200830	BOLT 8X30	1	
114	501407880	GUIDE ROLLER, D.C.	1	
115	020308060	NUT	1	
116	501407890	LEVER SPRING, D.C.	1	
117	031108160	WASHER, FLAT	1	
118	001220815	BOLT 8X15 T	1	
119	502910020	HANDLE STOPPER	1	

# MDR-9D — LOWER CONTROL HANDLE ASSY.

LOWER CONTROL HANDLE ASSY.

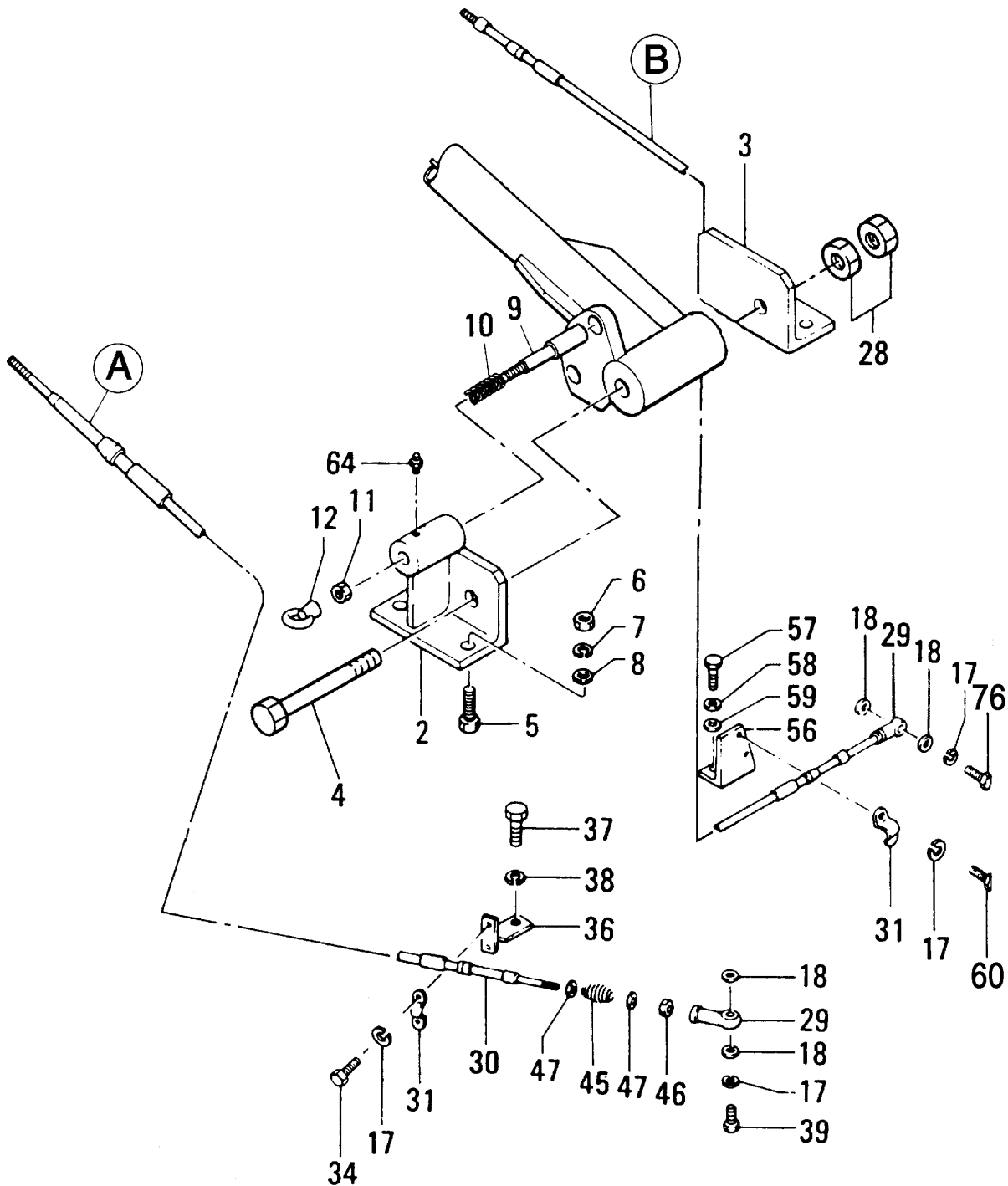

## NOTES:

- (A) UPPER CONTROL ARM ASSY., ITEM 30
- (B) UPPER CONTROL ARM ASSY., ITEM 53

## MDR-9D — LOWER CONTROL HANDLE ASSY.

### LOWER CONTROL HANDLE ASSY.

<u>NO.</u>	<u>PART NO.</u>	<u>PART NAME</u>	<u>QTY.</u>	<u>REMARKS</u>
2	501302670	HANDLE BRACKET, RIGHT	1	
3	501302680	HANDLE BRACKET, LEFT	1	
4	501402860	BOLT 20X170	1	
5	001221245	BOLT 12X45 T	4	
6	020312100	NUT M12	4	
7	030212300	WASHER, LOCK M12	4	
8	031112230	WASHER, FLAT M12	4	
9	501402870	HANDLE STOPPER	1	
10	501402880	SPRING/HANDLE (1.4X18X44)	1	
11	020310080	NUT	1	
12	959010413	EYE NUT	1	
28	020120160	NUT M20, P1.5	2	
29	501011162	ROD END PR6-209	3	
30	502314420	CABLE ASSY./C2110	1	
31	501011180	CLAMP HC-40	4	
34	001210615	BOLT 6X15 H	4	
36	502402900	CABLE STOPPER	1	
37	001221020	BOLT 10X20 T	1	
38	030210250	WASHER, LOCK	1	
39	001210620	BOLT 6X20 H	2	
45	0830000010	COIL SPRING	1	
46	020306050	NUT M6	4	
47	031106100	WASHER, FLAT M6	2	
56	502402890	CABLE STOPPER	1	
57	001220820	BOLT 8X20 T	2	
58	030208200	WASHER, LOCK	2	
59	031108160	WASHER, FLAT	2	
60	0012-20615	BOLT 6x15 T	4	
64	351010050	GREASE FITTING A-MT6X1	1	
76	001220620	BOLT 6X20 T	1	

# MDR-9D — BATTERY ASSY.

BATTERY ASSY.

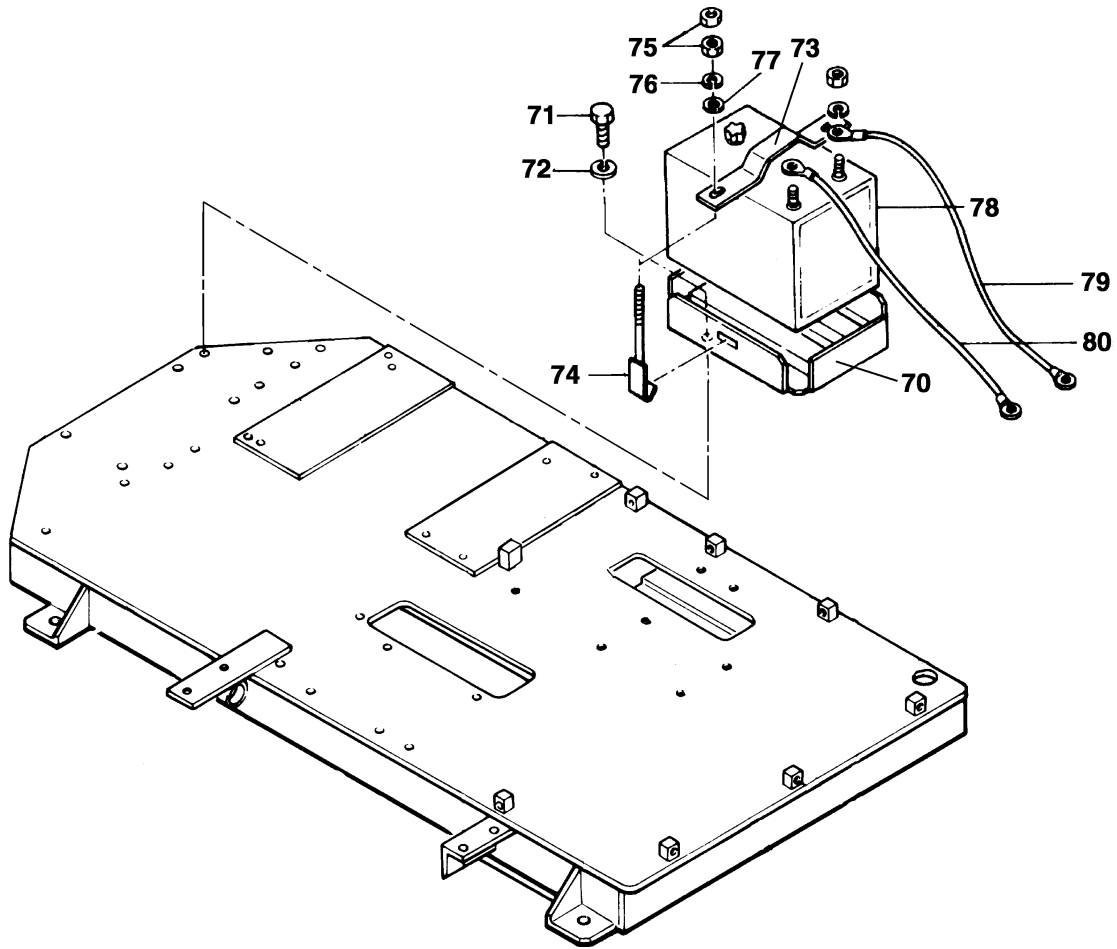

## BATTERY ASSY.

<u>NO.</u>	<u>PART NO.</u>	<u>PART NAME</u>	<u>QTY.</u>	<u>REMARKS</u>
70	502215490	BATTERY BASE	1	
71	001200815	BOLT 8X15	4	
72	030208200	SW M8	4	
73	502403310	BATTERY PROTECT	1	
74	502403320	BOLT/BATTERY	2	
75	020308060	NUT M8	4	
76	030208200	WASHER, LOCK M8	2	
77	031108160	WASHER, FLAT M8	2	
78	607010030	BATTERY 12N24-3.26A19L	1	
79	502301040	BATTERY CORD (+) 220	1	
80	502301050	BATTERY CORD (-) 380	1	

# HATZ 1D81Z ENGINE — CRANKCASE ASSY.

CRANKCASE ASSY.

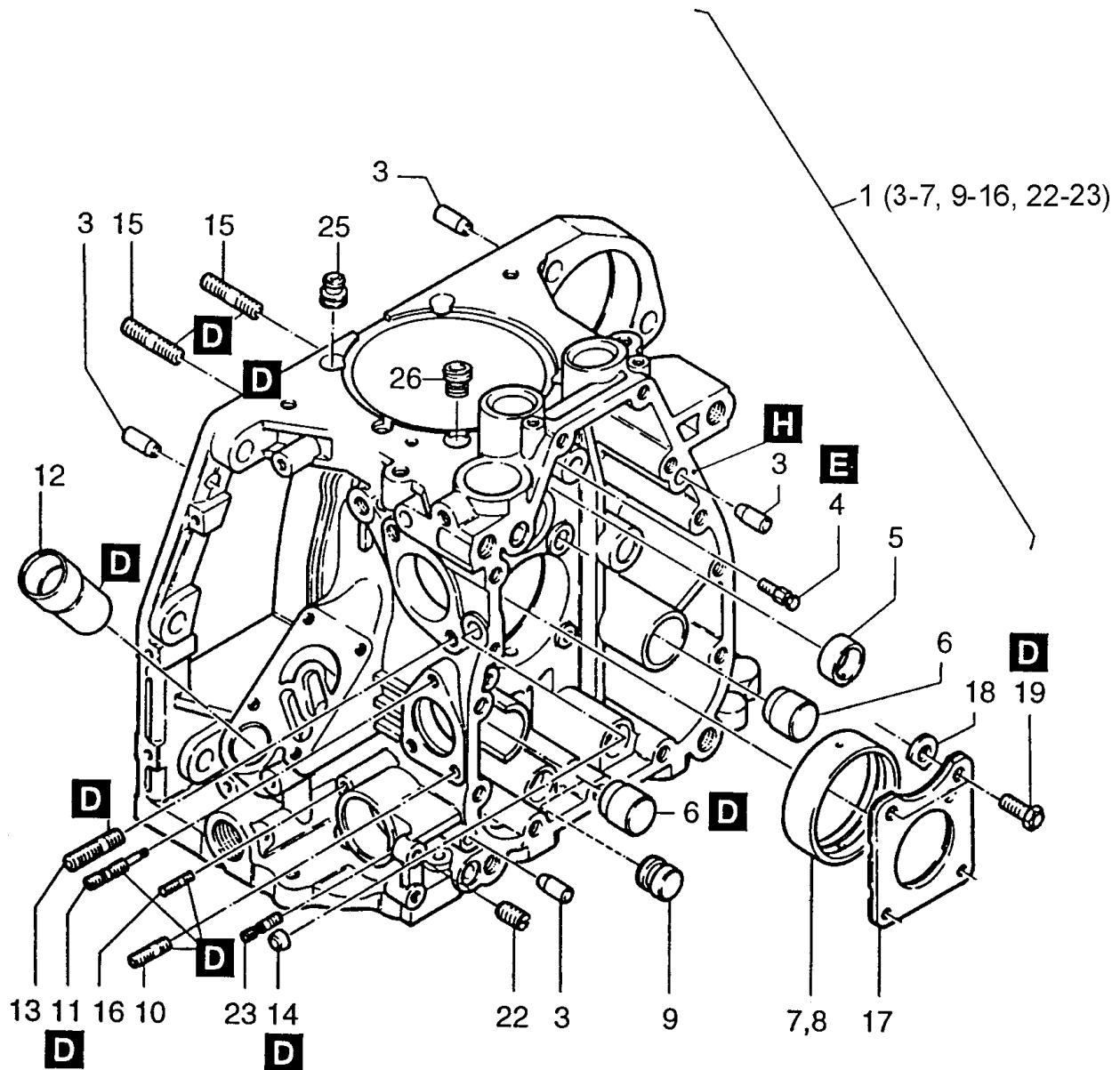

LETTERS IN BOLD INDICATE TYPE OF BONDING ADHESIVE TO BE USED.

D= LOCTITE 221 H= SILICON E= LOCTITE 648

# HATZ 1D81Z ENGINE — CRANKCASE ASSY.

## CRANKCASE ASSY.

<u>NO.</u>	<u>PART NO.</u>	<u>PART NAME</u>	<u>QTY.</u>	<u>REMARKS</u>
1	01249051	CRANKCASE .....	1	INCLUDES ITEMS W/*
3*	50249101	CYL. PIN 6/20	4	
4*	03793900	NOZZLE	1	
5*	03793800	BEARING BUSH	1	
6*	03794000	PLUG	1..2	
7*	03793700	MAIN BEARING	1	
8	04033700	MAIN BEARING -O.5	1	
9*	04000800	PLUG	1	
10*	50144300	STUD M 6X16	2	
11*	03794510	STUD	1	
12*	03794800	INTERMEDIATE PIECE	1	
13*	50098300	STUD 8 X 20	2	
14*	50325500	COVER 10	1	
15*	50037800	STUD M 8 X 22	8	
16*	50328200	STUD M 16 X 22	2	
17	04011650	THRUST PLATE	1	
18	04069500	SHIM 1.05	0..4	
19	04062010	HEX SCREW M 9 X 28	4	
22*	50357700	GRUB SCREW M 8 X 10	1	
23*	04087400	STUD M 6 X 22	1	
25	04084500	SEALING RING	2	
26	04084500	SEALING RING	2	

# HATZ 1D81Z ENGINE — CRANKCASE ASSY. (EXTERNAL PARTS)

## CRANKCASE ASSY.(EXTERNAL PARTS)

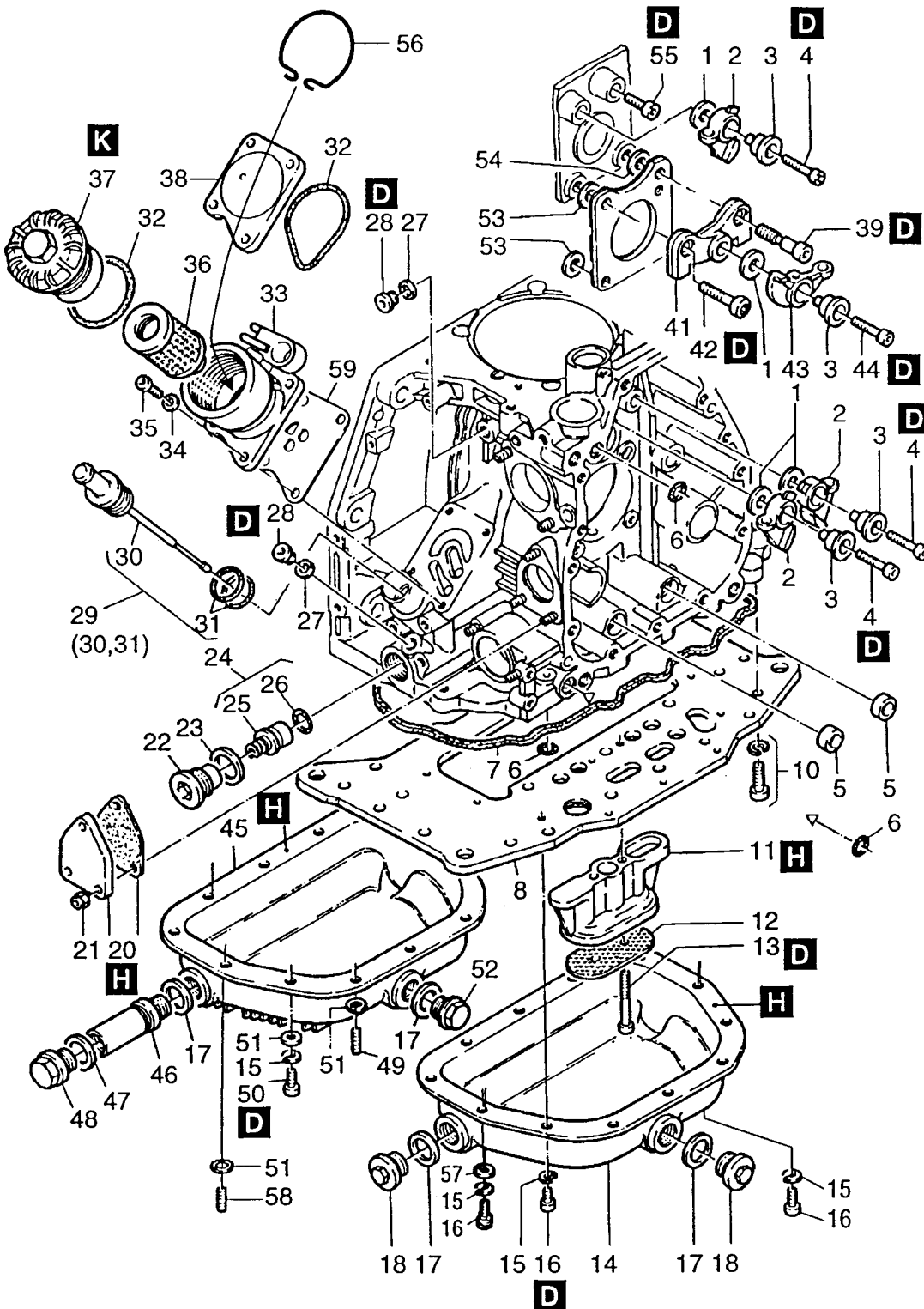

LETTERS IN BOLD INDICATE TYPE OF BONDING ADHESIVE TO BE USED.

D= LOCTITE 221 H= SILICON E= LOCTITE 648



# HATZ 1D81Z ENGINE — CRANKCASE ASSY. (EXTERNAL PARTS)

## CRANKCASE ASSY.(EXTERNAL PARTS)

<u>NO.</u>	<u>PART NO.</u>	<u>PART NAME</u>	<u>QTY.</u>	<u>REMARKS</u>
1	03794100	WASHER	2	
2	03794300	CAM FOLLOWER	2	
3	93794201	CAM FOLLOW SPINDLE	2	
4	50051000	ALLEN SCREW M 6 X 30	2	
5	03795800	O-RING 12 X 18, 3 X 7.3	2	
6	50329000	O-RING 9.5 X 2.5	3	
7	03795100	O-RING 265 X 269, 4 X 3.6	1	
8	01248810	PLATE	1	
10	50417600	ALL. SCREW. M 8 X 25 Z4	22	
11	03794900	HOUSING	1	
12	03795000	SUCTION SIEVE	1	
13	50327100	ALLEN SCREW M 6 X 50	2	
14	01241700	OIL SUMP	1	
15	50170900	WASHER, LOCK 6	12	
16	50329100	ALLEN SCREW M 6 X 10	12	
17	50001600	JOINT A22X27	2	
18	50373100	DRAIN PLUG M 22 X 1.5	0..2	
18	50140400	DRAIN PLUG	0..2	
20	03794700	COVER	1	
21	50328300	HEXAGON NUT M6	3	
22	01321200	CLOS. SCREW + SIEVE	1	
23	50286400	JOINT A 24 X 29	1	
24	01321100	OIL RELIEF VALVE ASSY. ....	1	INCLUDES ITEMS W/#
25#		OIL RELIEF VALVE .....	1	CANNOT BE PURCHASED SEPARATELY
26#	50412900	O-RING 18 X 2	1	
27	50062400	JOINT A10 X 13.5	2	
28	50062300	CLOSING SCREW X 1	2	
29	01241500	DIPSTICK ASSY .....	1	INCLUDES ITEMS W/*
30*		DIPSTICK .....	1	CANNOT BE PURCHASED SEPARATELY
31*	50359700	O-RING 20.29 X 2.62	2	
32	50329200	O-RING 50X55X3	2	
33	05068800	LUB. OIL FILT. HOUS.	1	
34	50081200	WASHER, LOCK A6	4	
35	50170600	ALLEN SCREW M 6 X 20	4	
36	01480000	SUPRA OIL FILTER	1	
37	01248900	COVER	1	
38	04033401	COVER	1	
39	04053210	SET SCREW M9	1	
41	04024220	CAM FOLLOWER BRACK.	1	
42	04062110	BOLT	1	
43	04024301	CAM FOLLOWER T/U	1	
44	50170800	ALLEN SCREW M 6 X 25	1	
45	04045800	OIL SUMP	1	
46	04046300	DRAIN EXTENSION	1	
47	50001400	JOINT A 18 X 22	1	
48	50044200	CLOS. SCREW M 18 X 1.5	1	
49	50434300	STUD M 8 X 18	2	
50	50050700	ALLEN SCREW M 6 X 16	8	
52	50140400	DRAIN PLUG	1	
53	04069500	SHIM 1.05	0..3	
53	04069600	SHIM 1.2	0..3	
54	04069800	SHIM 1.05	0..1	
54	04069900	SHIM 1.20	0..1	
55	04065400	CYLINDER HEAD BOLT	1	
56	04084000	LIFTING SPRING	1	
58	50139200	STUD M 6 X 16	2	
59	05068900	GASKET	1	

# HATZ 1D81Z ENGINE — CRANKSHAFT ASSY.

## CRANKSHAFT ASSY.

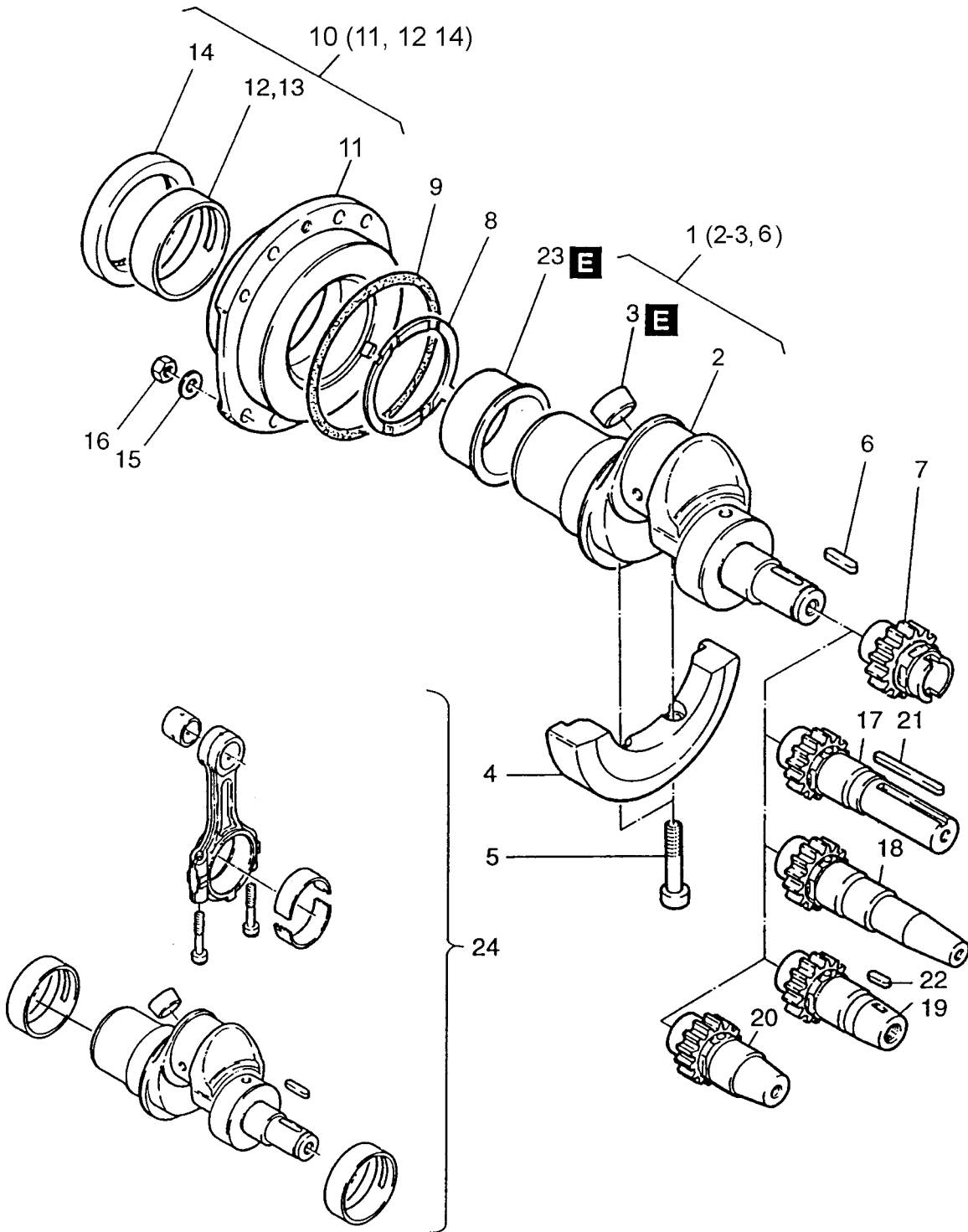

LETTERS IN BOLD INDICATE TYPE OF BONDING ADHESIVE TO BE USED.

D= LOCTITE 221 H= SILICON E= LOCTITE 648

# HATZ 1D81Z ENGINE — CRANKSHAFT ASSY.

## CRANKSHAFT ASSY.

<u>NO.</u>	<u>PART NO.</u>	<u>PART NAME</u>	<u>QTY.</u>	<u>REMARKS</u>
1	01269810	CRANKSHAFT ASSY. ....	1	INCLUDES ITEMS W/*
2*		CRANKSHAFT .....	1	CANNOT BE PURCHASED SEPARATELY
3*	50087200	COVER 28	1	
4	03796000	COUNTER WEIGHT	1	
5	50055000	ALLEN SCREW M 10 X 50	2	
6*	50362600	FITTING KEY A 6 X 4 X 32	1	
7	03796120	GEARWHEEL F. CRANKS	1	
8	04000600	BUFFER RING	1	
9	50224900	O-RING 123 X 2.5	1	
10	01292100	BEARING FLANGE ASSY. ....	1	INCLUDES ITEMS W/#
11#		BEARING FLANGE .....	1	CANNOT BE PURCHASED SEPARATELY
12#	04006800	MAIN BEARING		
13	04036100	MAIN BEARING -0.5	1	
14#	50362700	OIL SEAL 62 X 90 X 10	1	
15	50413600	WASHER	8	
16	50364300	HEXAGON NUT	8	
17	04023110	STUBSHAFT SAE W/KEY	1	
18	01485500	STUBSHAFT SAE TAPER	1	
19	04022910	STUBSHAFT ITALIA	1	
20	05033200	STUBSHAFT ITALIA 23	1	
21	03962700	FITTING KEY A6.35 X 63	1	
22	50017800	WOODRUFF KEY 4 X 6.5	1	
23	50414400	WEAR SLEEVE 62 X 12.7	0..1	
24	01512001	KIT, CRANKSHAFT REPLACEMENT60-81	1	



# HATZ 1D81Z ENGINE — CAMSHAFT ASSY.

## CAMSHAFT ASSY.

<u>NO.</u>	<u>PART NO.</u>	<u>PART NAME</u>	<u>QTY.</u>	<u>REMARKS</u>
1	03796400	SHAFT	2	
2	03796500	BUSH	2	
3	01242000	GEARWHEEL	2	
4	04099900	CAMSHAFT	1	
5	03796800	GEARWHEEL	1	
6	03796900	GEARWHEEL	1	
7	01267300	SHAFT, PUMP SIDE.....	1	INCLUDES ITEMS W/★
8	01267200	SHAFT STARTER SIDE.....	1	INCLUDES ITEMS W/#
9★		COUNTER BALANCE.....	1	CANNOT BE PURCHASED SEPARATELY
10	50324900	WOODRUFF KEY 3 X 3.7	2	
11★#		PIN.....	2	CANNOT BE PURCHASED SEPARATELY
12#		COUNTER BALANCE.....	1	CANNOT BE PURCHASED SEPARATELY

# HATZ 1D81Z ENGINE — PISTON/RINGS ASSY.

PISTON/RINGS ASSY.

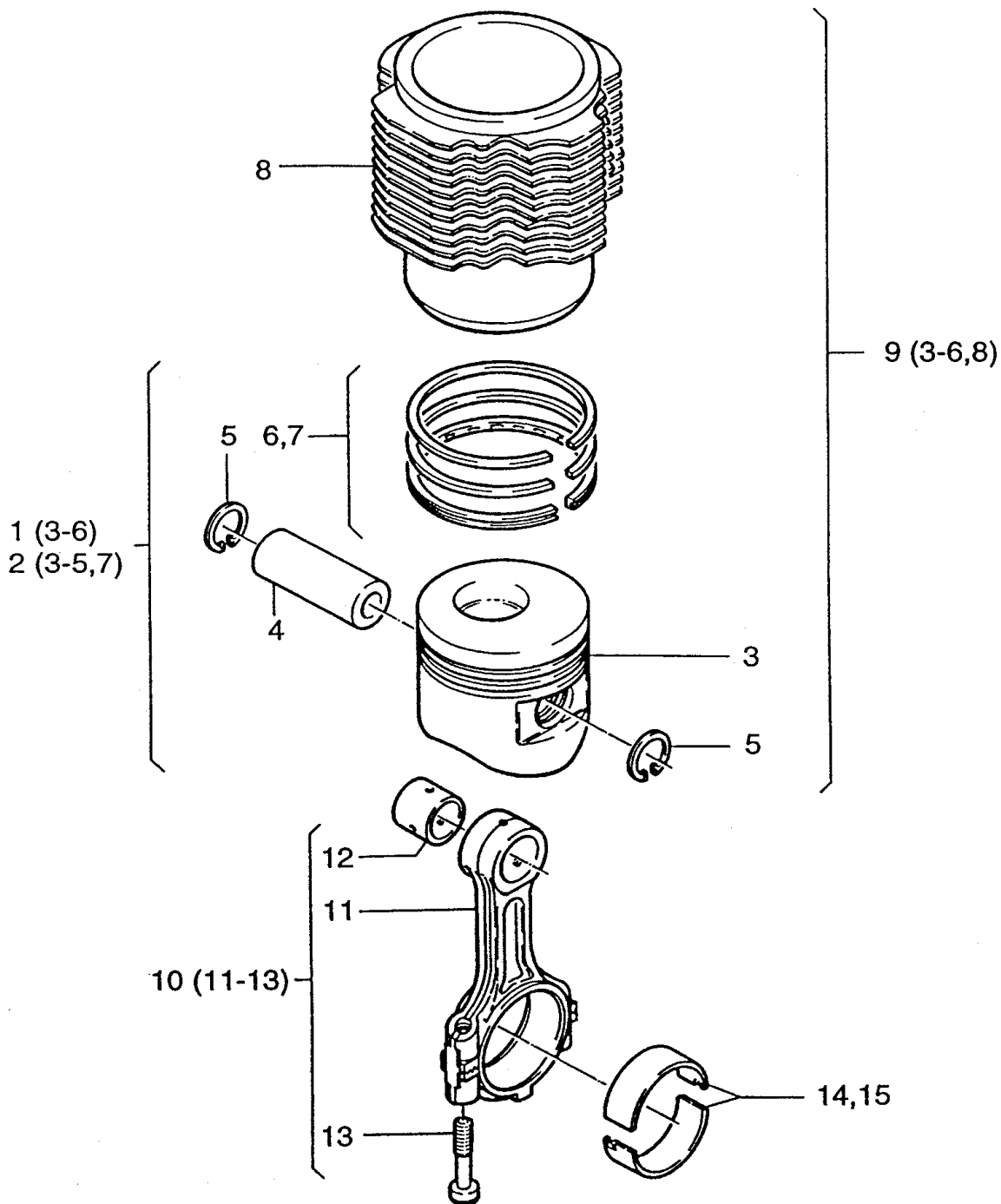

# HATZ 1D81Z ENGINE — PISTON/RINGS ASSY.

## PISTON/RINGS ASSY.

<b>NO.</b>	<b>PART NO.</b>	<b>PART NAME</b>	<b>QTY.</b>	<b>REMARKS</b>
1	01243901	PISTON ASSY. STD. ....	1	INCLUDES ITEMS W/*
1	01313510	PISTON ASSY. OVERSIZED .....	1	INCLUDES ITEMS W/*
2	01265101	PISTON ASSY. 100+0.5 .....	1	INCLUDES ITEMS W/#
2	01265201	PISTON ASSY. 100+1.0 .....	1	INCLUDES ITEMS W/#
2	01314610	PISTON ASSY. 100+0.5 .....	1	INCLUDES ITEMS W/#
2	01314710	PISTON ASSY. 100+1.0 .....	1	INCLUDES ITEMS W/#
3*#+		PISTON .....	1	CANNOT BE PURCHASED SEPARATELY
4*#+	50353600	WRIST PIN	1	
5*#+	50020800	CIRCLIP 30 X 1.2	2	
6*+	01247300	PISTON RING SET 100	1	
7#	01264500	PISTON RING SET +0.5	1	
7#	01265000	PISTON RING SET +1.0	1	
8+		CYLINDER .....	1	CANNOT BE PURCHASED SEPARATELY
9	01508301	CYLINDER ASSY. W/ PISTON .....	1	INCLUDES ITEMS W/+
10	01244001	CONROD ASSY. ....	1	INCLUDES ITEMS W/%
11%		CONROD .....	1	CANNOT BE PURCHASED SEPARATELY
12%	04032200	BUSH FOR CONROD	1	
13%	04001800	CONROD SCREW	2	
14	04001900	BIG END BEARING	1	
15	04033100	ROD BEARING -0.5	1	

# HATZ 1D81Z ENGINE — CYLINDER HEAD ASSY.

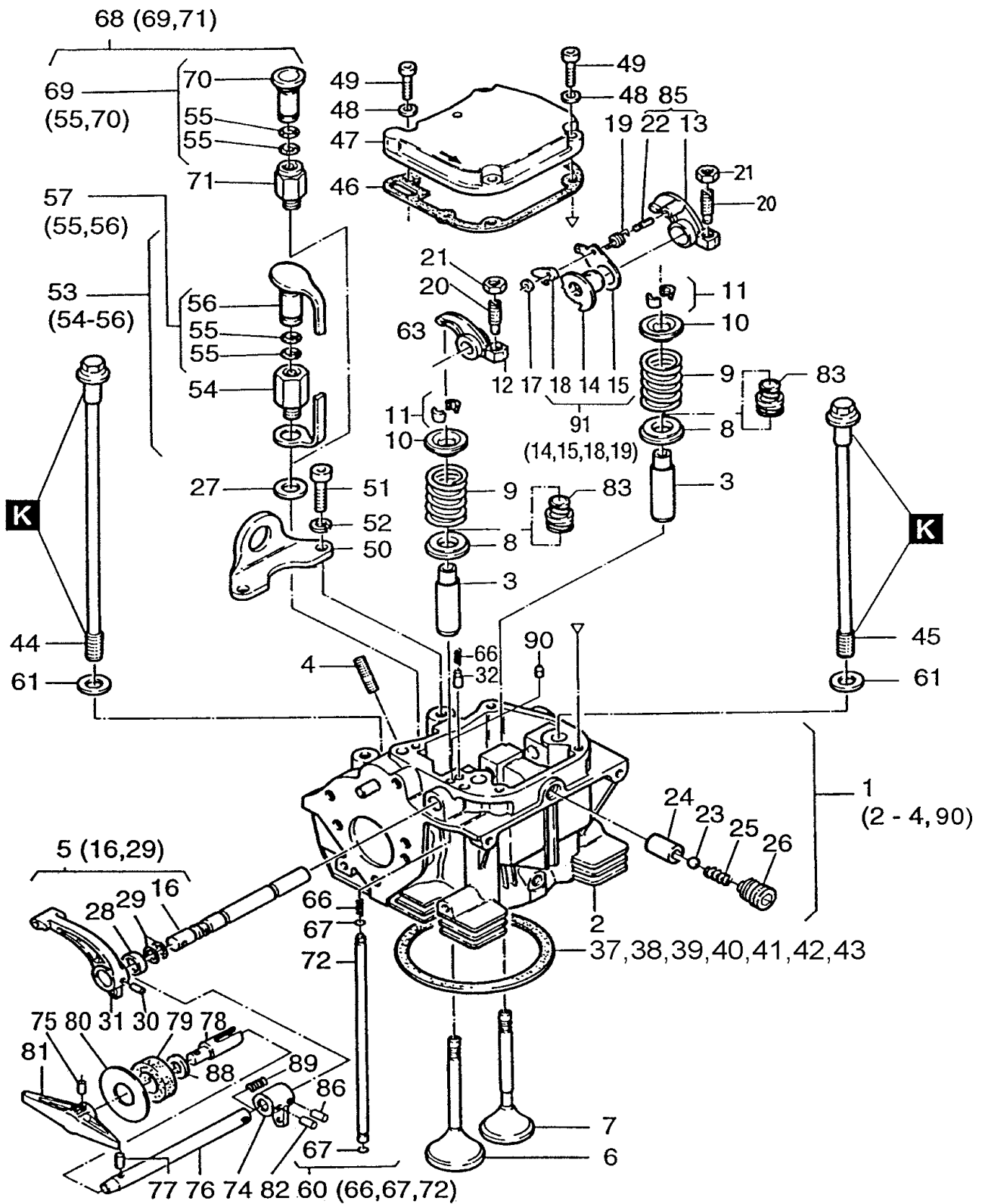

K= HOT TEMPERATURE FELT 100g



# HATZ 1D81Z ENGINE — CYLINDER HEAD ASSY.

## CYLINDER HEAD ASSY.

<u>NO.</u>	<u>PART NO.</u>	<u>PART NAME</u>	<u>QTY.</u>	<u>REMARKS</u>
1	01264810	CYLINDER HEAD ASSY.....	1	INCLUDES ITEMS W/*
1	01499610	CYLINDER HEAD ASSY.....	1	INCLUDES ITEMS W/*
2*		CYLINDER HEAD .....	1	CANNOT BE PURCHASED SEPARATELY
3*	04008710	VALVE GUIDE	2	
4*	50038400	STUD M 8 X 35	1	
5	04068910	ROCKER SHAFT ASSY. "C" .....	1	INCLUDES ITEMS W/+
5	04068920	ROCKER SHAFT ASSY.....	1	INCLUDES ITEMS W/+
6	04005001	VALVE INLET	1	
6	04091001	VALVE INLET	1	
7	04005101	VALVE EXHAUST	1	
7	04091100	VALVE EXHAUST	1	
8	04005201	WASHER	2	
9	04005300	VALVE SPRING	2	
10	04005401	CUP	2	
11	03786300	VALVE COLLET	2	
12	04003710	ROCKER INLET	1	
13#		ROCKER INLET .....	1	CANNOT BE PURCHASED SEPARATELY
14%		RATCHET WHEEL .....	1	CANNOT BE PURCHASED SEPARATELY
15%	03778401	SPRING SHEET	1	
16+		ROCKER SHAFT .....	1	CANNOT BE PURCHASED SEPARATELY
17	50117200	CIRCLIP	1	
18%	03365710	RATCHET F. DECOMPR.	1	
19	03366001	SPRING	1	
20	03783000	ADJUSTING SCREW	2	
21	03173100	HEXAGON NUT	2	
22#		DOWEL PIN .....	1	CANNOT BE PURCHASED SEPARATELY
23	50123800	BALL 7MM III	1	
24	04004700	BUSH	1	
25	04004800	PRESSURE SPRING	1	
26	01245200	ADJUSTING SCREW	1	
27	50001100	JOINT A 12 X 15.5	1	
28	04048900	RUBBER RING	1	
29+	40022401	O-RING 8 X 2 GRAY	1..2	
30	50034700	PIN 4 X 22	1	
31	04009810	HANDLE	1	
32	04004100	PIN	1	
35	04068800	GASK. F. CYL. HEAD 0.5	0..1	
36	04036800	GASK. F. CYL. HEAD 0.6	0..1	
37	04036500	GASK. F. CYL. HEAD 0.7	0..1	
38	04036600	GASK. F. CYL. HEAD 0.8	0..1	
39	04002700	GASK. F. CYL. HEAD 0.9	0..1	
40	04002800	GASK. F. CYL. HEAD 1.0	0..1	
41	04002900	GASK. F. CYL. HEAD 1.1	0..1	
42	04003000	GASK. F. CYL. HEAD 1.2	0..1	
43	04003100	GASK. F. CYL. HEAD 1.3	0..1	
44	04003200	CYL. HEAD SCREW 305 MM	2	
45	04003300	CYL. HEAD SCREW 258 MM	2	
46	04006111	VALVE COVER GASKET 16>	1	
47	01245410	VALVE COVER	1	
48	50081200	WASHER, LOCK A6	4	
49	50170800	ALLEN SCREW M 6 X 25	4	
50	04008100	LIFTING BRACKET	1	

# HATZ 1D81Z ENGINE — CYLINDER HEAD ASSY.

## CYLINDER HEAD ASSY.

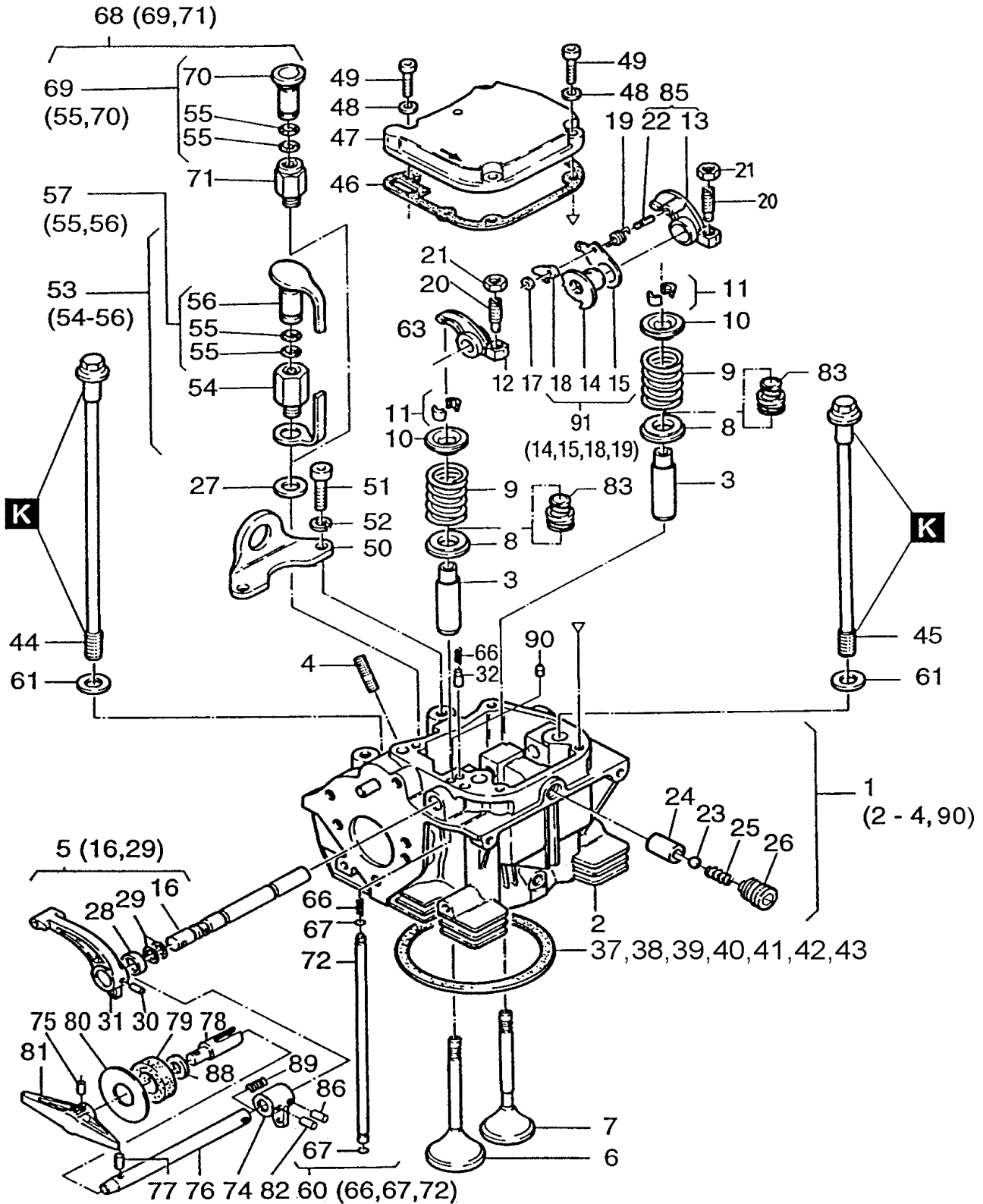

# HATZ 1D81Z ENGINE — CYLINDER HEAD ASSY.

## CYLINDER HEAD ASSY.

NO.	PART NO.	PART NAME	QTY.	REMARKS
51	50366300	ALLEN SCREW M 8X 20	2	
52	50208500	WASHER, LOCK 8	2	
53	01493200	DEVICE HOUSING .....	1	INCLUDES ITEMS W/■
54■		HOUSING DEVICE BASE .....	1	CANNOT BE PURCHASED SEPARATELY
55■✓+	40081700	O-RING 12 X 16 X2	2	
56■✓		CAP .....	1	CANNOT BE PURCHASED SEPARATELY
57	01308300	CLOSING PLUG .....	1	INCLUDES ITEMS W/✓
60	01269700	OIL PRESSURE PIPE	1	INCLUDES ITEMS W/⊗
61	03457500	DISC F. STUD	4	
66⊗	04004200	PRESSURE SPRING	1	
67⊗	50330100	O-RING 4 X 1.2	2	
68	01280600	OIL FILTER DEVICE .....	1	INCLUDES ITEMS W/⊗
69⊗	01275610	CLOSING PLUG ASSY 46MM .....	1	INCLUDES ITEMS W/+
70+		CLOSING PLUG .....	1	CANNOT BE PURCHASED SEPARATELY
71⊗		TUBE .....	1	CANNOT BE PURCHASED SEPARATELY
72⊗		ROD .....	1	CANNOT BE PURCHASED SEPARATELY
74	04047920	INTERM. PIECE DECOMP.	1	
75	50132000	ROLL PIN 4 X 16	1	
76	04048220	DECOMPRESSION SHAFT "C"	1	
77	50034500	ROLL PIN 4 X 14	1	
78	04048110	INTERMEDIATE PIECE	1	
79	03579800	RUBBER WASHER	1	
80	04048000	WASHER 10.5 X 50 X 0.8	1	
81	03778200	HANDLE 6 X 18	1	
82	50132000	ROLL PIN 4 X 16	1	
83	50405200	VALVE STEM SEAL CAP	2	
85	01285010	ROCKER EXHAUST .....	1	INCLUDES ITEMS W/#
86	50034600	ROLL PIN 4 X 18	1	
88	03787300	SHIM 0.2	1	
89	04097200	PRES. SPRING DECOMPR.	1	
90*	04038500	OIL RESTRICTOR VALVE ASSY.	1	
90*	04104300	OIL RESTRICTOR VAVE	1	
91	01557600	GEARWHEEL F. DECOMPR. ....	1	INCLUDES ITEMS W/%

# HATZ 1D81Z ENGINE — FLYWHEEL ASSY.

FLYWHEEL ASSY.

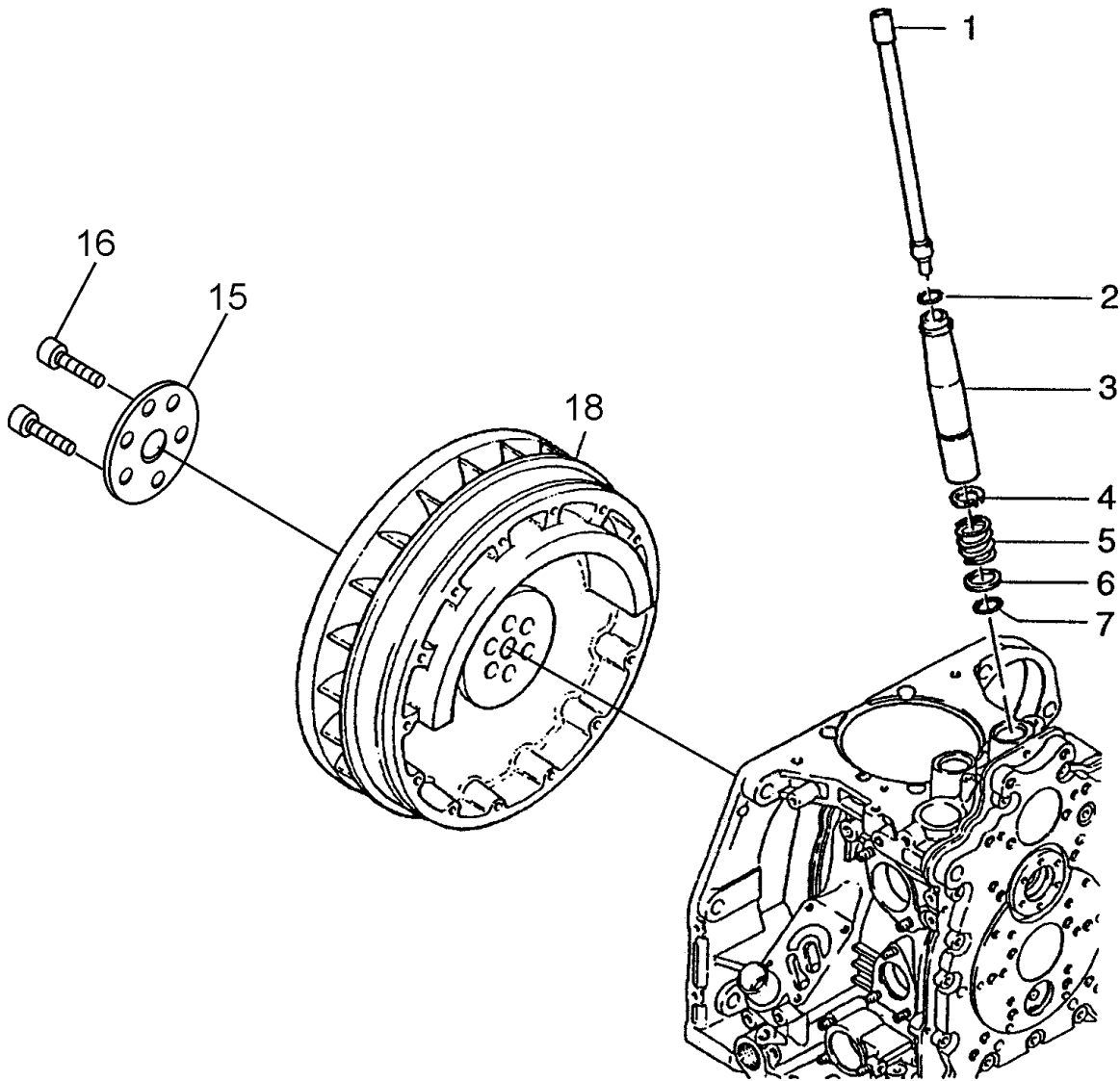

# HATZ 1D81Z ENGINE — FLYWHEEL ASSY.

## FLYWHEEL ASSY.

<u>NO.</u>	<u>PART NO.</u>	<u>PART NAME</u>	<u>QTY.</u>	<u>REMARKS</u>
1	01244310	PUSHROD	2	
2	50330200	O-RING 19 X 3N	2	
3	04002500	PROTECTION TUBE	2	
4	50347000	CIRCLIP AS 24 X 1.75	2	
5	04002000	PRESSURE SPRING	2	
6	04002000	PRESSURE RING	2	
7	50330300	O-RING 23 X 3	2	
15	04007410	PLATE	1	
16	50363100	ALLEN SCREW M 10 X 40	6	
18	04007131	FLYWHEEL, ELECTRIC START	1	

# HATZ 1D81Z ENGINE — OIL PUMP ASSY.

OIL PUMP ASSY.

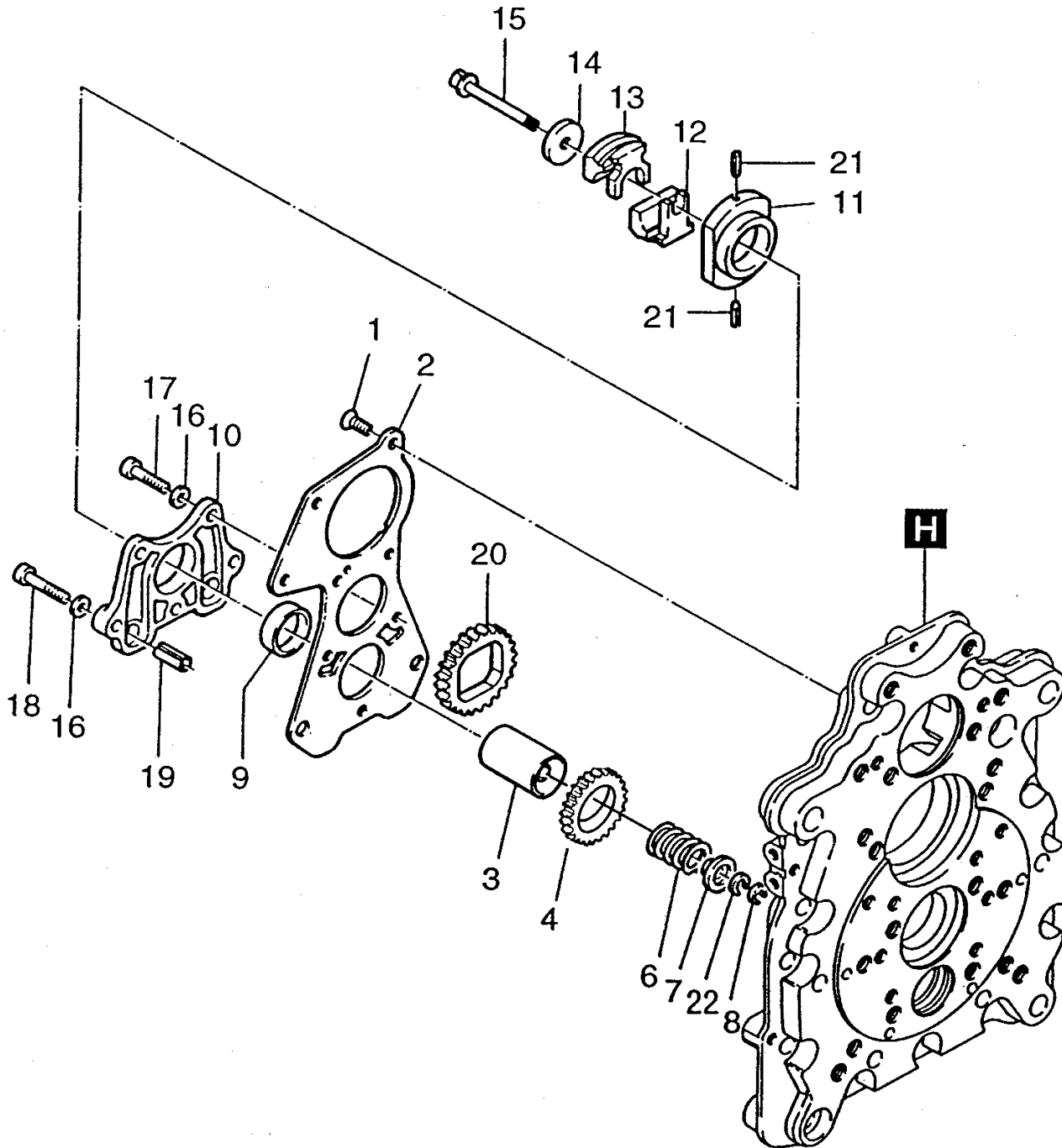

LETTERS IN BOLD INDICATE TYPE OF BONDING ADHESIVE TO BE USED.

D= LOCTITE 221 H= SILICON E= LOCTITE 648

# HATZ 1D81Z ENGINE — OIL PUMP ASSY.

## OIL PUMP ASSY.

<u>NO.</u>	<u>PART NO.</u>	<u>PART NAME</u>	<u>QTY.</u>	<u>REMARKS</u>
1	50328000	CTR. SUNK SCR.AM 6 X 16	5	
2	03797412	COVER F. OIL PUMP	1	
3	01242401	SPRING CAPSULE+BUSH	1	
4	03797310	GEARWHEEL	1	
6	04063400	GOVERNOR SPRING 2.9	1	
7	03798600	CUP	1	
8	50334700	CIRCLIP5	1	
9	03797600	BEARING BUSH	1	
10	03797510	HOUSING	1	
11	03797701	PLATE CENTRIF. WEIGHT	1	
12	03798002	CENTRIFUGAL WEIGHT	1	
13	03798102	CENTRIFUGAL WEIGHT	1	
14	03797900	WASHER	1	
15	03797801	PIN	1	
16	50081200	WASHER, LOCK A6	5	
17	50170800	ALLEN SCREW M 6 X 25	3	
18	50051000	ALLEN SCREW M 6 X 30	2	
19	50084901	PIN 8 X 12	2	
20	03798720	GEARWHEEL	1	
21	50260501	ROLL PIN 2 X 10	2	
22	04046000	CIRCLIP	0.3	

# HATZ 1D81Z ENGINE — TIMING COVER ASSY.

TIMING COVER ASSY.

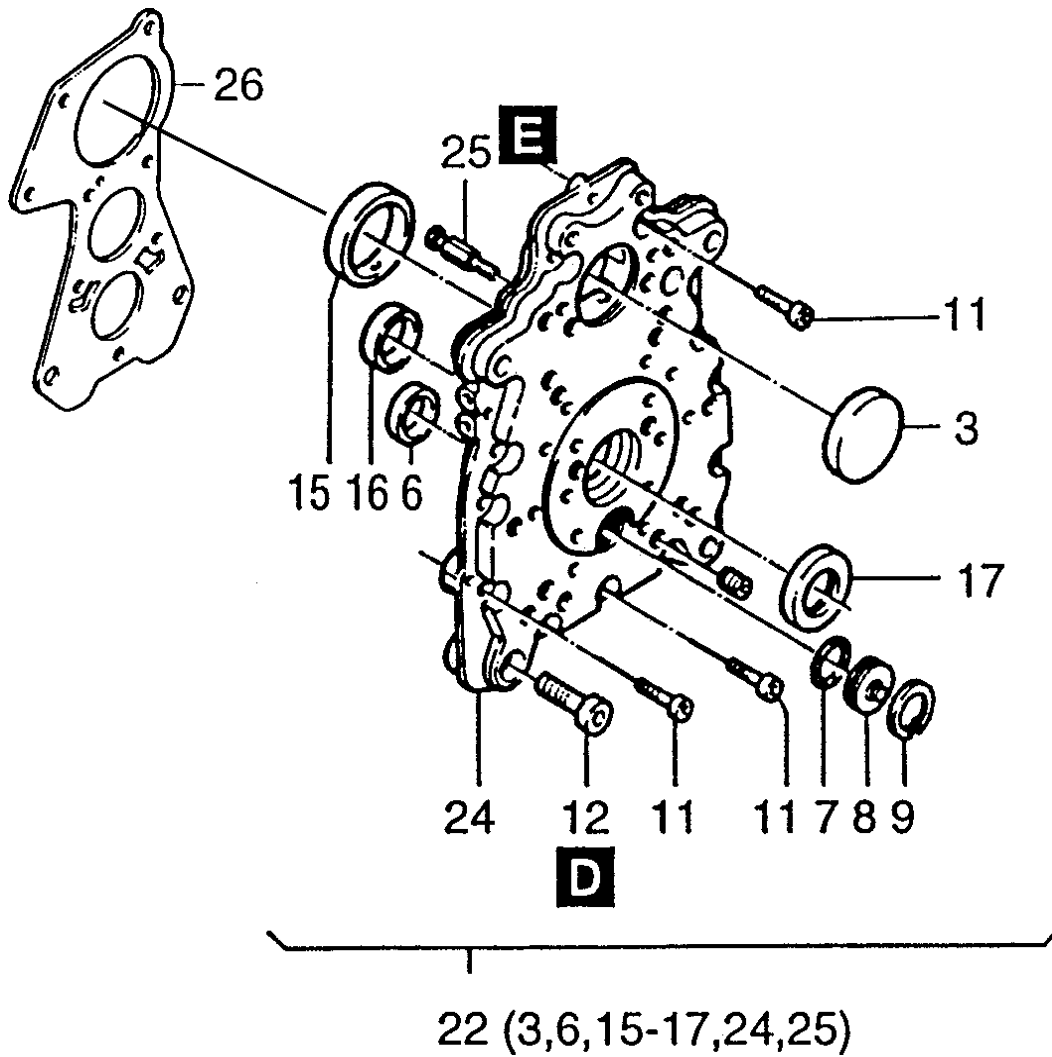

LETTERS IN BOLD INDICATE TYPE OF BONDING ADHESIVE TO BE USED.

D= LOCTITE 221 H= SILICON E= LOCTITE 648



# HATZ 1D81Z ENGINE — TIMING COVER ASSY.

## TIMING COVER ASSY.

<u>NO.</u>	<u>PART NO.</u>	<u>PART NAME</u>	<u>QTY.</u>	<u>REMARKS</u>
3#	05325600	COVER 50	1	
6#	03797600	BEARING BUSH	1	
7	50330400	O-RING 27 X 2N	1	
8	04000400	COVER	1	
9	50399000	CIRCLIP 32 X 1.2	1	
11	50417400	ALLEN SCREW M 8 X 30 Z3	13	
12	50329500	ALLEN SCREW M 12 X 40	1	
15#	04000310	BEARING BUSH	1	
16#	04023210	BEARING BUSH	1	
17#	50364700	OIL SEAL 32 X 52 X 7	1	
22	01281001	TIMING COVER ASSY. NO. 3 .....	1	INCLUDES ITEMS W/#
24#		TIMING COVER .....	1	CANNOT BE PURCHASED SEPARATELY
25#	04052400	NOZZLE	1	
26	03797412	COVER F. OIL PUMP	1	

# HATZ 1D81Z ENGINE — FUEL DEVICE ASSY.

## FUEL DEVICE ASSY.

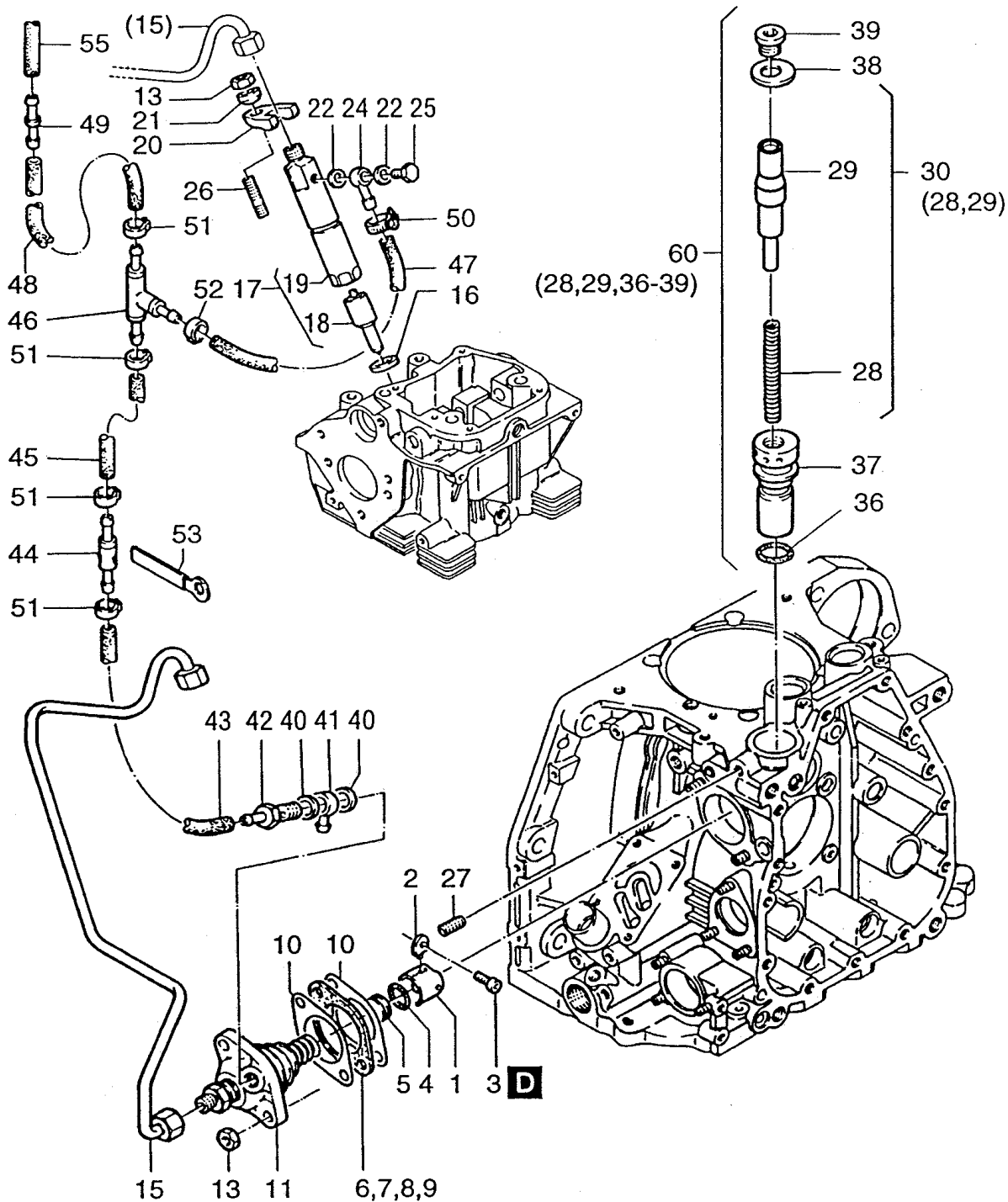

LETTERS IN BOLD INDICATE TYPE OF BONDING ADHESIVE TO BE USED.

D= LOCTITE 221 H= SILICON E= LOCTITE 648

# HATZ 1D81Z ENGINE — FUEL DEVICE ASSY.

## FUEL DEVICE ASSY.

<u>NO.</u>	<u>PART NO.</u>	<u>PART NAME</u>	<u>QTY.</u>	<u>REMARKS</u>
1	50331500	ROLLER TAPPET CPL.	1	
2	04000901	GUIDE	1	
3	50050700	ALLEN SCREW M 6 X 16	1	
4	50390200	O-RING 17 X 1.1	0..1	
4	50363400	O-RING 17 X 1.2	0..1	
5	04011700	PLATE	1	
6	03209700	SHIM 0.3	0..1	
7	04102400	SHIM 0.60/42.2	0..1	
8	04102500	SHIM 0.90/42.2	0..1	
9	04102600	SHIM 1.20/42.2	0..1	
10	04071300	GASKET	0.2	
10	04102200	GASKET INJECTION PUMP 0.2	0..2	
10	04102300	GASKET INJECTION PUMP 0.3	0..2	
11	50416200	INJECTION PUMP	1	
13	50148000	HEXAGON NUT	3	
15	01313600	FUEL PRESSURE PIPE	1	
16	04025800	JOINT WASHER	1	
16	40085001	INJECTOR SEAL	1	
17	50415101	INJECTOR .....	1	INCLUDES ITEMS W/%
18%	50415200	NOZZLE DLLA 154PV3	1	
19%		INJECTOR .....	1	CANNOT BE PURCHASED SEPARATELY
20	03792400	FLANGE	1	
21	04035700	WASHER	1	
22	50000800	COPPER WASHER	2	
24	50333400	BANJO UNION	1	
25	50313000	BANJO BOLT M6	1	
26	50038400	STUD M 8 X 35	1	
27	50004600	SET SCREW AM 8 X 16	1	
28*#	05035200	PRESSURE SPRING	1	
29*#		PIN .....	1	CANNOT BE PURCHASED SEPARATELY
30	01519500	PIST. + SPRG. EXT. FUEL .....	1	INCLUDES ITEMS W/*
36#	50328900	O-RING 22 X 1.6	1	
37#	04001410	CYL. F. EXTR. FUEL DEV.	1	
38#	04001600	DISC.	1	
39#	50330800	CLOS. SCREW M 16 X 1.5	1	
40	50001100	JOINT A12 X 15.5	2	
41	50015800	RING PIECE NW6	1	
42	03662300	PIPE NIPPLE	1	
43	04060400	FUEL HOSE 4.5 X 100	1	
44	00805500	VENT VALVE	1	
45	03807100	FUEL HOSE 4.5/150	1	
45	04060200	FUEL HOSE 4.5 X 55	1	
46	50157800	T-CONNECTION NW3	1	
47	03902000	FUEL PIPE 390	1	
48	05029600	FUEL HOSE 4.5/850	1	
49	50279600	CONNECTING NIPPLE	1	
50	50357200	HOSE CLIP 5SKZ	2	
51	50399801	CLAMP 11.3	4	
52	50399900	CLAMP 9.5	1	
53	01459700	CLIP	1	
60	01498902	PIST. + CYL. EXTR. FUEL .....	1	INCLUDES ITEMS W/#

# HATZ 1D81Z ENGINE — AIR DUCTING ASSY.

AIR DUCTING ASSY.

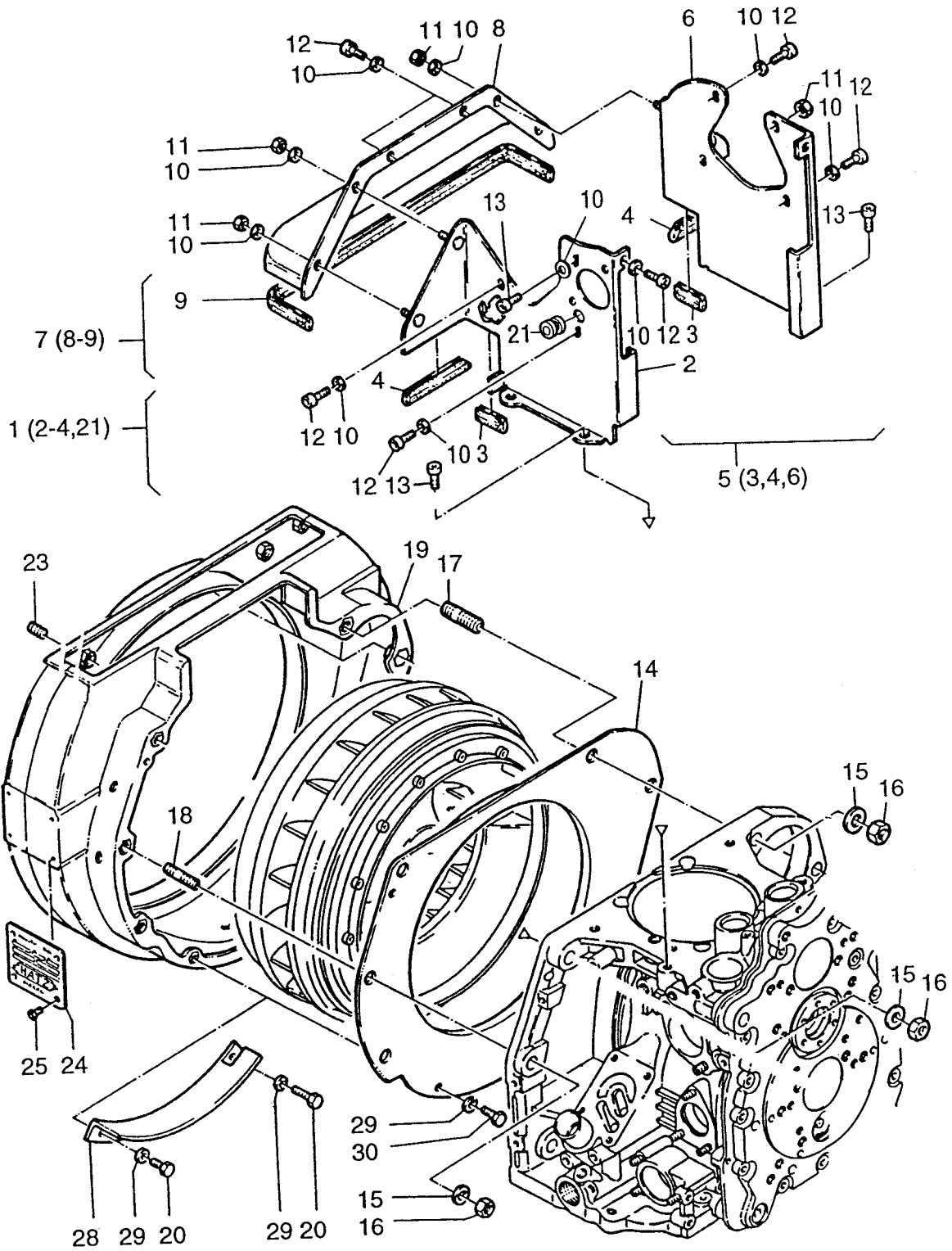

# HATZ 1D81Z ENGINE — AIR DUCTING ASSY.

## AIR DUCTING ASSY.

<u>NO.</u>	<u>PART NO.</u>	<u>PART NAME</u>	<u>QTY.</u>	<u>REMARKS</u>
1	01246220	COOLING AIR DUCT ASSY .....	1 .....	INCLUDES ITEMS W/*
2*		COOLING AIR DUCT .....	1 .....	CANNOT BE PURCHASED SEPARATELY
3*%	04007601	SEALING STRIP 32.2MM	2	
4*%	04007720	SEALING STRIP 76MM	2	
5	01246411	COOLING AIR DUCT .....	1 .....	INCLUDES ITEMS W/%
6%		SIDE SHROUD .....	1 .....	CANNOT BE PURCHASED SEPARATELY
7	01246600	COOLING AIR DUCT ASSY. ....	1 .....	INCLUDES ITEMS W/#
8#		COOLING AIR DUCT .....	1 .....	CANNOT BE PURCHASED SEPARATELY
9#	04007901	SEALING STRIP 413MM	1	
10	50081200	WASHER, LOCK A6	15	
11	50144400	HEXAGON NUT M6	4	
12	50149100	ALLEN SCREW M6 X 12	12	
13	50206300	ALLEN SCREW X 18	4	
14	04008500	PARTING SHEET	1	
15	50093700	WASHER, FLAT A13	6	
16	50093600	HEXAGON NUT M12	6	
17	50364900	STUD M12 X 40	2	
18	50331400	STUD M12 X 35	4	
19	04008211	INTERMED. HOUSING	1	
20	50333500	HEXSCREW M 6 X 8	2	
21*	50334800	RUBBER SLEEVE	1	
23	50226000	GRUB SCREW M 8 X 6	4	
24	03225504	NAME PLATE	1	
25	40002500	POP RIVET 2.4 MM	4	
28	04080400	COVER F. BLOW DUCTING	1	
29	50170900	WASHER, LOCK 6	4	
30	50177100	HEXSCREW M 6 X 16	2	

# HATZ 1D81Z ENGINE — BREATHER ASSY.

BREATHER ASSY.

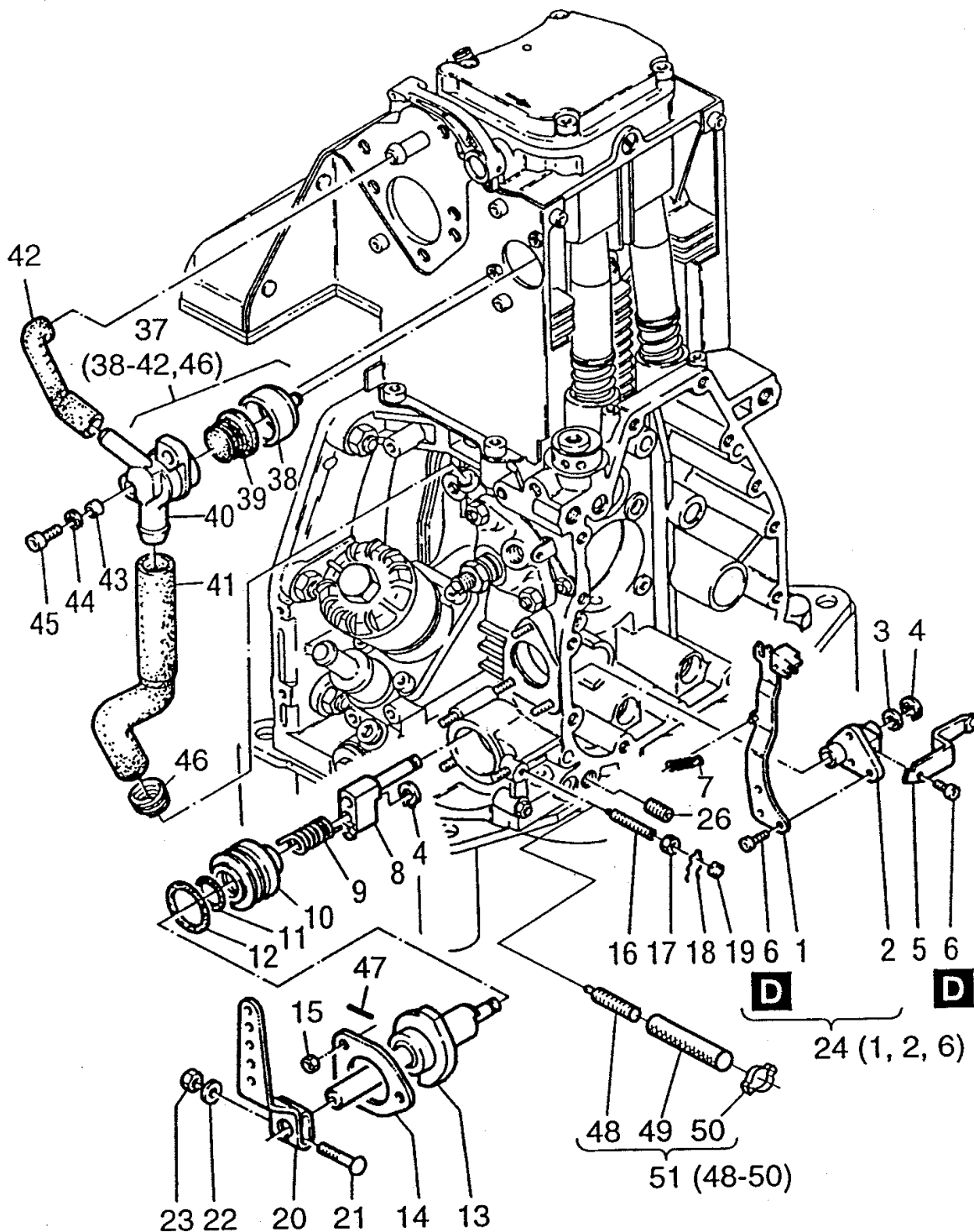

LETTERS IN BOLD INDICATE TYPE OF BONDING ADHESIVE TO BE USED.

D= LOCTITE 221 H= SILICON E= LOCTITE 648

# HATZ 1D81Z ENGINE — BREATHER ASSY.

## BREATHER ASSY.

<u>NO.</u>	<u>PART NO.</u>	<u>PART NAME</u>	<u>QTY.</u>	<u>REMARKS</u>
1#		THROTTLE ARM .....	1 .....	CANNOT BE PURCHASED SEPARATELY
2#		THROTTLE LINKAGE .....	1 .....	CANNOT BE PURCHASED SEPARATELY
3	04000100	SHIM	1	
4	50266100	CIRCLIP 6	2	
5	04037500	LEVER	1	
6#	50328701	ALLEN SCREW M 5 X 8	4	
7	04000200	TENSION SPRING	1	
8	01242810	GUIDE	1	
9	03799010	THIGH SPRING	1	
10	04052700	SPACER RING	1	
11	50386100	O-RING 21 X 2	1	
12	50129900	O-RING 32 X 37 X 2.5	1	
13	01279210	STOP RING SPD. CONT. S	1	
13	01302910	STOP RING SPD. CONT. C	1	
14	03799210	FRICITION PLATE	1	
15	50328300	HEXAGON NUT M6	3	
16	03799400	GRUB SCREW	2	
17	50144400	HEXAGON NUT M6	2	
18	40021500	SEAL WIRE 0.5-0.3	2	
19	40021400	LEAD SEAL 8MM	2	
20	03888300	THROTTLE LEVER	1	
21	03927300	SCREW M 6 X 32	1	
22	50144500	WASHER, FLAT 6.4	1	
23	50144400	HEXAGON NUT M6	1	
24	01246801	GOVERNOR LEVER ASSY. ....	1 .....	INCLUDES ITEMS W/#
26	50403500	GRUB SCREW M 8 X 20	1	
37	01317000	BREATHER VALVE ASSY. ....	1 .....	INCLUDES ITEMS W/%
38%	04080300	BREATHER CUP	1	
39%	03568700	RUBBER DIAPHRAM	1	
40%		BREATHER .....	1 .....	CANNOT BE PURCHASED SEPARATELY
41%	04074700	BREATHER HOSE	1	
42%	04074800	BREATHER HOSE	1	
43	04080500	BUSH	2	
44	50081200	WASHER, LOCK A6	2	
45	50170700	ALLEN SCREW M 6 X 16	2	
46%	04090500	CLIP	1	
47	50411500	SET PIN	1	
48*	50405301	GRUB SCREW M 6 X 45	1	
49*	05038000	HOSE 7 X 12 X 120	1	
50*	50388300	HOSE CLAMP	1	
51	01475600	ADJUST. SCREW ID 1D81 .....	1 .....	INCLUDES ITEMS W/*

# HATZ 1D81Z ENGINE — FUEL TANK ASSY.

## FUEL TANK ASSY.

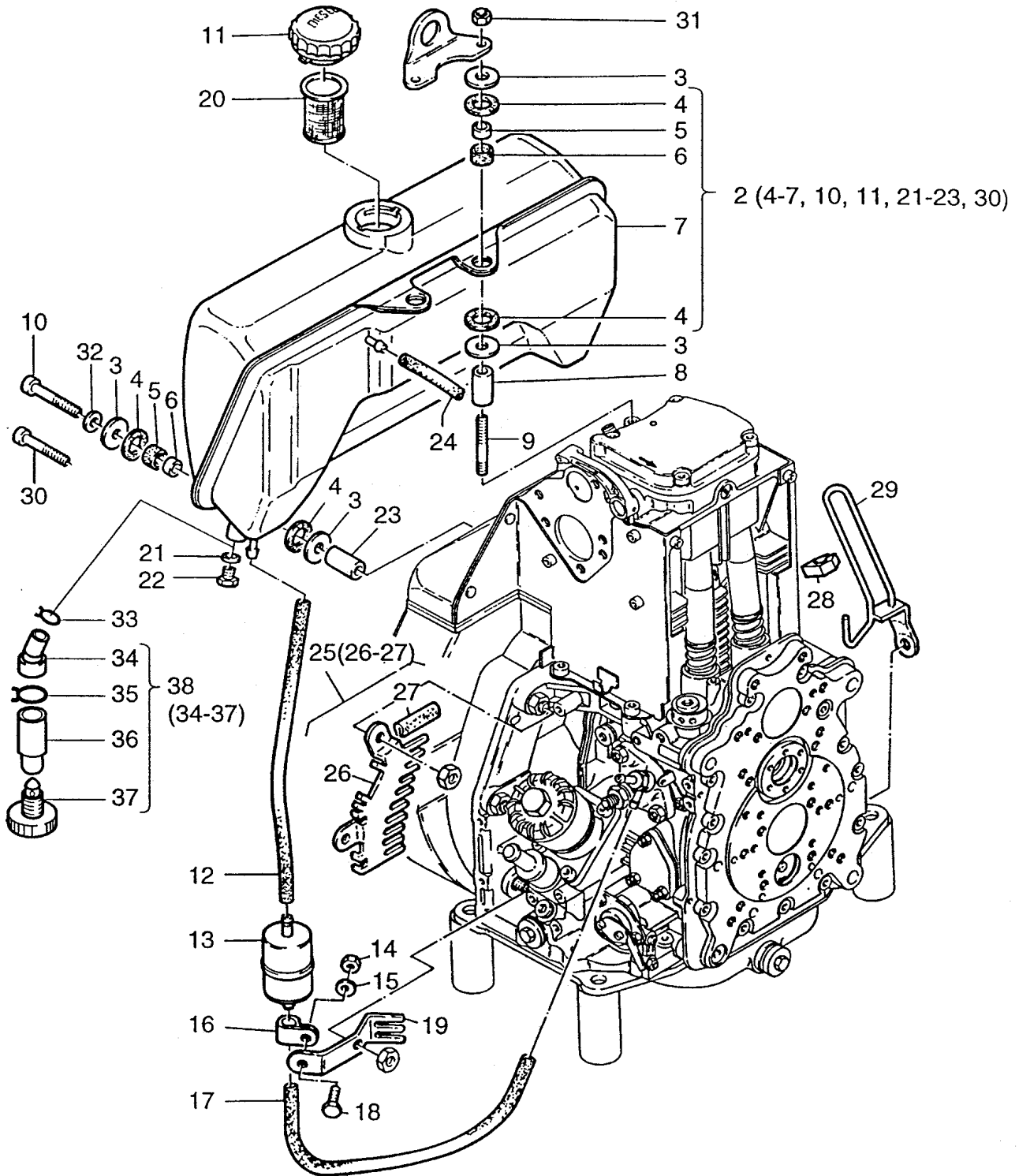



# HATZ 1D81Z ENGINE — FUEL TANK ASSY.

## FUEL TANK ASSY.

<u>NO.</u>	<u>PART NO.</u>	<u>PART NAME</u>	<u>QTY.</u>	<u>REMARKS</u>
2	01494200	FUEL TANK ASSY ( 7 LTRS.) .....	1	INCLUDES ITEMS W/#
3	05097600	WASHER	12	
4#	03981802	RUBBER WASHER	12	
5#	03981701	BUSH 8.4 X 13 X 7.5	6	
6#	03981900	RUBBER SHELL	6	
7#		FUEL TANK .....	1	CANNOT BE PURCHASED SEPARATELY
8	03989800	BUSH 8.5 X 20 X 49	2	
9	50377001	STUD M 8 X 75	2	
10#	50177500	ALLEN SCREW M 8 X 40	4	
11#	50385800	CAP, FUEL TANK	1	
12	03801200	FUEL HOSE 7/220	1	
13	50478800	FUEL FILTER .....	1	REPLACES 40089401
14	50144400	HEXAGON NUT M6	1	
15	50144500	WASHER, FLAT 6.4	1	
16	03165500	PIPE CLIP	1	
17	03493600	FUEL HOSE 7/330	1	
18	50165500	HEXSCREW M 6 X 12	1	
19	05031900	GUARD	1	
20	50387300	SIEVE	1	
21#	50001000	JOINT A 10 X 16	1	
22#	50359800	HEXSCREW M 10 X 12	1	
23#	05029200	BUSH 9 X 18 X 8	4	
24	03663700	FUEL PIPE L W 4.5 X 50	1	
25	01490300	PROTEC. GUARD TOP .....	1	INCLUDES ITEMS W/%
26%		FINGER GUARD .....	1	CANNOT BE PURCHASED SEPARATELY
27%	04030901	SEALING STRIP 29 MM	1	
28	03150900	CLAMP	1	
29	01402200	GUARD	1	
30#	50183000	ALLEN SCREW M 8 X 35	4	
31	50148000	HEXAGON NUT	2	
32	50208500	WASHER, LOCK 8	4	
33	05045300	CLAMP 21 MM	1	
34*	05044001	HOSE 10/12 MM	1	
35*	05036900	HOSE CLIP	1	
36*	05043900	WATER SEPARATOR	1	
37*	50414800	CLOS. SCREW M 10	1	
38	01519401	WATER SEPARATOR.....	1	INCLUDES ITEMS W/*

# HATZ 1D81Z ENGINE — FUEL PUMP ASSY.

FUEL PUMP ASSY.

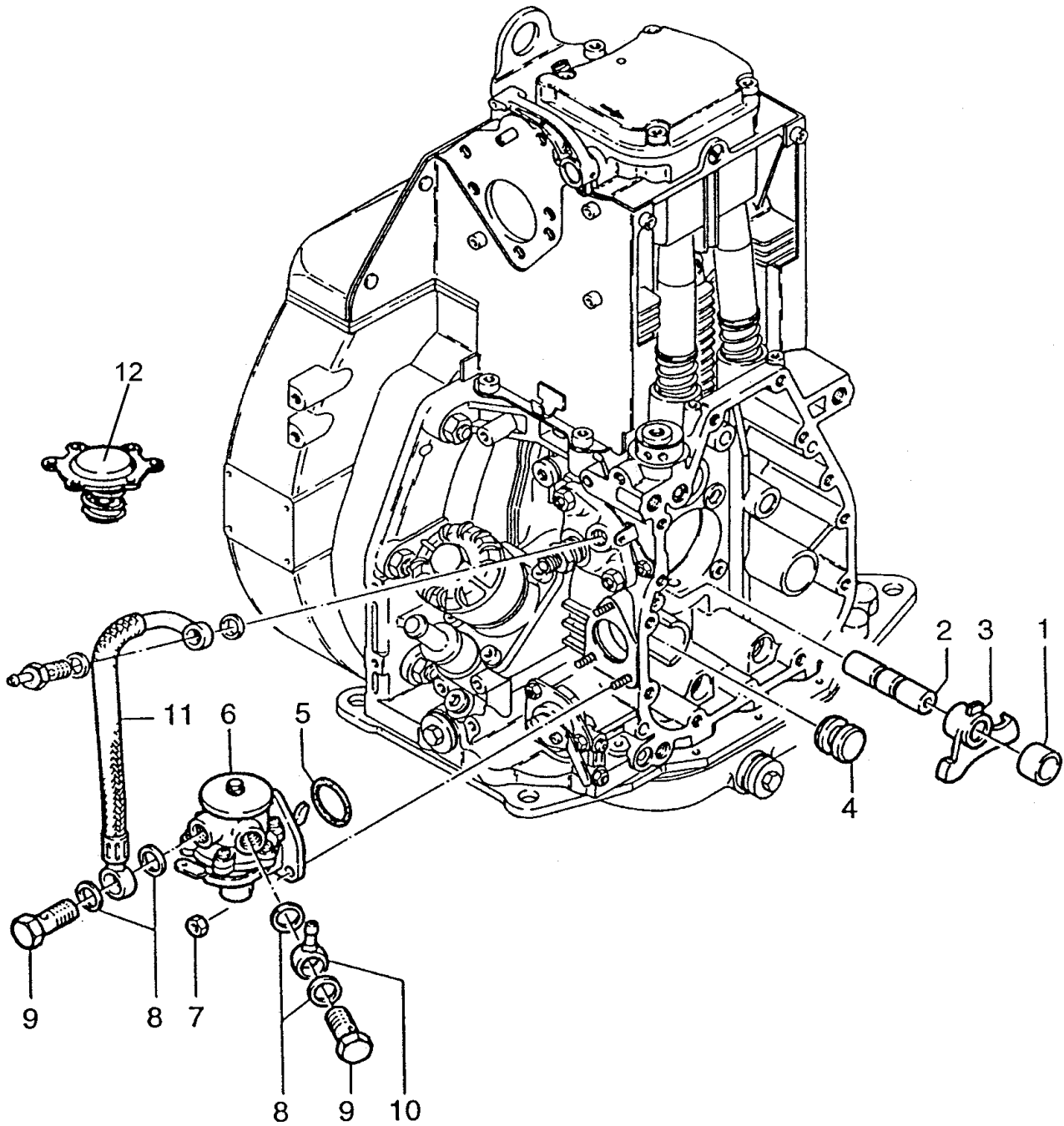

# HATZ 1D81Z ENGINE — FUEL PUMP ASSY.

## FUEL PUMP ASSY.

<u>NO.</u>	<u>PART NO.</u>	<u>PART NAME</u>	<u>QTY.</u>	<u>REMARKS</u>
1	04011900	BUSH	1	
2	03796400	SHAFT	1	
3	04011801	LEVER F. FEED PUMP	1	
4	04000800	PLUG	1	
5	50331800	O-RING	1	
6	50332301	FUEL FEED PUMP	1	
7	50328300	HEXAGON NUT M6	3	
8	50001200	JOINT A 14 X 18	4	
9	50006400	BANJO BOLT A8	2	
10	50015900	RING PIECE N W 8	1	
11	01468801	FUEL PIPE	1	
12	49062501	DIAPHRAM	1	

# HATZ 1D81Z ENGINE — AIR FILTER ASSY.

AIR FILTER ASSY.

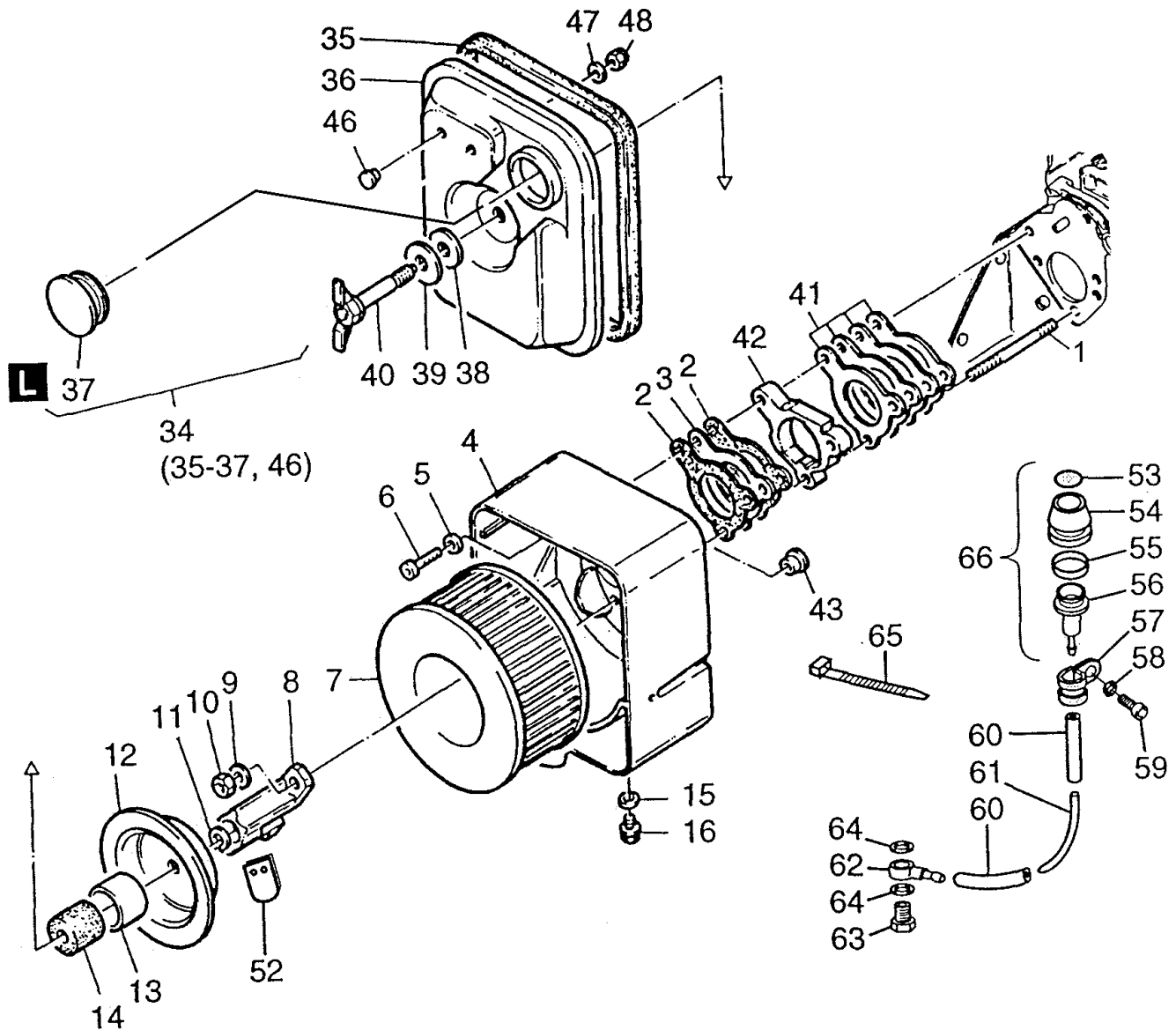

L= SILICON SEALER

# HATZ 1D81Z ENGINE — AIR FILTER ASSY.

## AIR FILTER ASSY.

<u>NO.</u>	<u>PART NO.</u>	<u>PART NAME</u>	<u>QTY.</u>	<u>REMARKS</u>
1	50038900	STUD M 8 X 60	2	
2	04006300	GASKET	2	
3	04006200	INSULATING FLANGE	1	
4	04004312	AIRFILTER HOUSING	1	
5	50095100	WASHER, LOCK A8	1	
6	50398400	CYLINDER HEAD BOLT	1	
7	01493000	AIR FILTER	1	
8	01483400	RETAINING STRAP	1	
9	50148100	WASHER, FLAT 8.4	2	
10	50129500	HEXAGON NUT	2	
11	50412000	CIRCLIP 10 X 1	1	
12	05036400	CENTERING COVER	1	
13	05039300	BUSH 33 X 35 X 23.5	1	
14	03579400	SEALING RING	1	
15	50062400	JOINT A 10 X 13.5	1	
16	50062300	CLOSING SCREW M 10 X 1	1	
34	01496800	COVER AIRFILTER .....	1	INCLUDES ITEMS W/*
35*	04047701	SEALING STRIP LG 704	1	
37*	05039401	CLOSING CAP	1	
36*		CLOSING COVER .....	1	CANNOT BE PURCHASED SEPARATELY
38	03814100	INSULATING DISC	1	
39	05038700	WASHER 11 X 36 X 3	1	
40	01490800	WING SCREW	1	
41	01287900	GASKET AIRFILTER	1	
42	04047300	INTERMEDIATE FLANGE	1	
43	50395700	COVER 15	1	
46*	50411900	CLOSING PLUG 7	2	
47	50120000	DISC A 6.4	2	
48	40028300	HEXAGON NUT M 6	2	
52	05033500	VALVE PLATE	1	
53#	05044501	INDIC. PLATE	1	
54#	05043601	RUBBER CAP	1	
55#	05045600	SIGNAL RING	1	
56#	05043700	ADAPTER	1	
57	50173500	PIPE CLIP	1	
58	50170900	WASHER, LOCK 6	1	
59	50170600	ALLEN SCREW M 6 X 20	1	
60	03961400	FUEL HOSE 3.51-50	2	
61	05043800	HOSE 2 X 4 X 170	1	
62	50159500	RING PIECE N W 4	4	
63	50006200	BANJO BOLT A 4	1	
64	50062400	JOINT A 10 X 13.5	2	
65	50358400	STRAP	1	
66	01499800	MAINT. INDICATOR .....	1	INCLUDES ITEMS W/#

# HATZ 1D81Z ENGINE — EXHAUST SILENCER ASSY.

EXHAUST SILENCER ASSY.

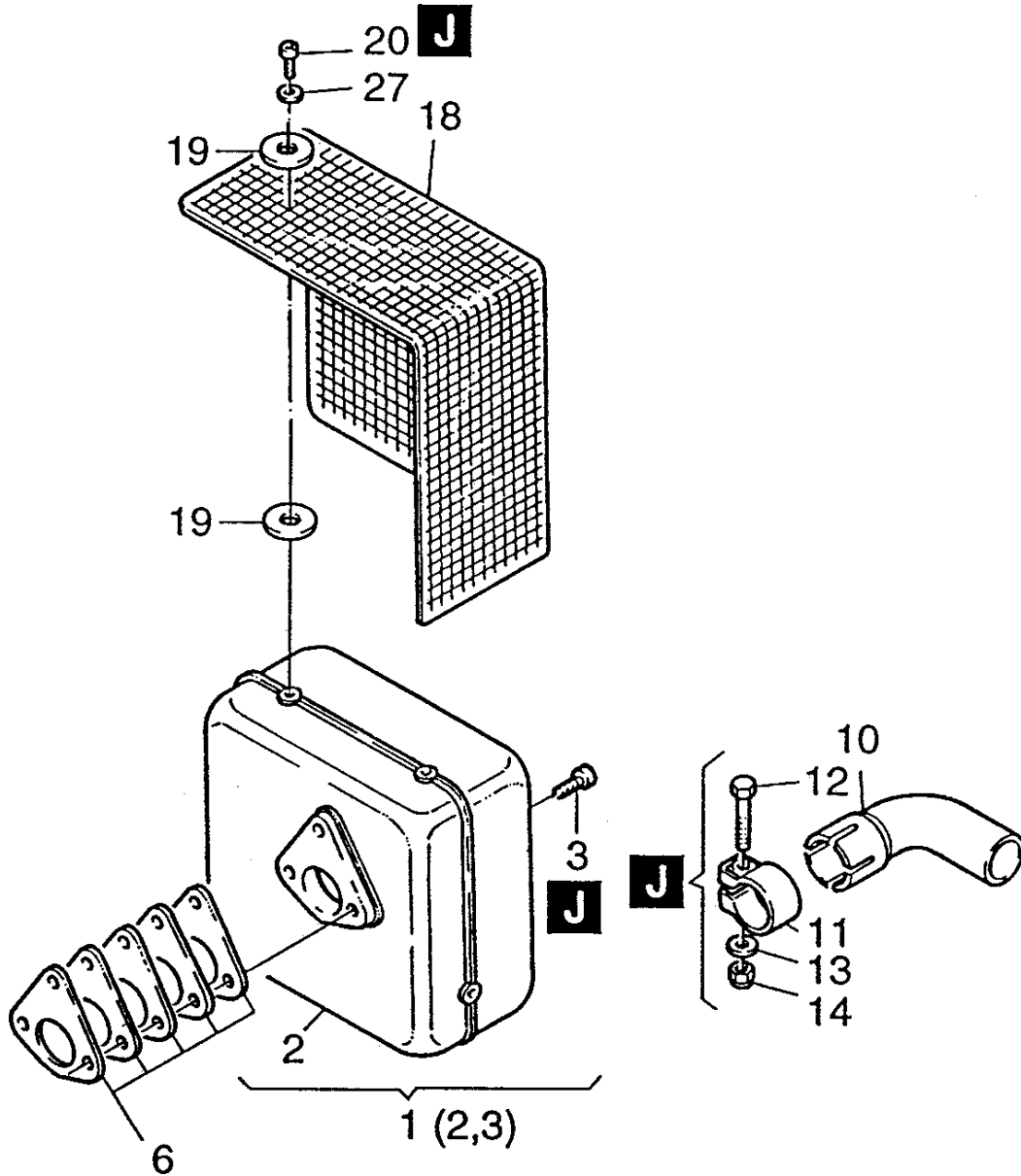

J= HOT TEMPERATURE PASTE

# HATZ 1D81Z ENGINE — EXHAUST SILENCER ASSY.

## EXHAUST SILENCER ASSY.

<u>NO.</u>	<u>PART NO.</u>	<u>PART NAME</u>	<u>QTY.</u>	<u>REMARKS</u>
1	01498800	EXHAUST SILENCER S ASSY. ....	1	INCLUDES ITEMS W/*
2*		EXHAUST SILENCER .....	1	CANNOT BE PURCHASED SEPARATELY
3*	50404000	ALLEN SCREW M 8 X 30	3	
6	01471110	GASKET SET EXHAUST SIL.	1	
10	03877300	ELBOW	1	
11	03877700	PIPE CLIP 52.5	1	
12	50249500	HEX SCREW M 10 X 50	1	
13	50145900	WASHER, FLAT 10.5	1	
14	40028600	HEX NUT M 10	1	
16	03997100	EXHAUST TUBE	1	
18	01191901	MUFFLER GUARD ID	1	
19	05034200	WASHER, LOCK	10	
20	50255700	ALLEN SCREW M 6 X 12	5	

# HATZ 1D81Z ENGINE — STARTER/ALTERNATOR ASSY.

## STARTER/ALTERNATOR ASSY.

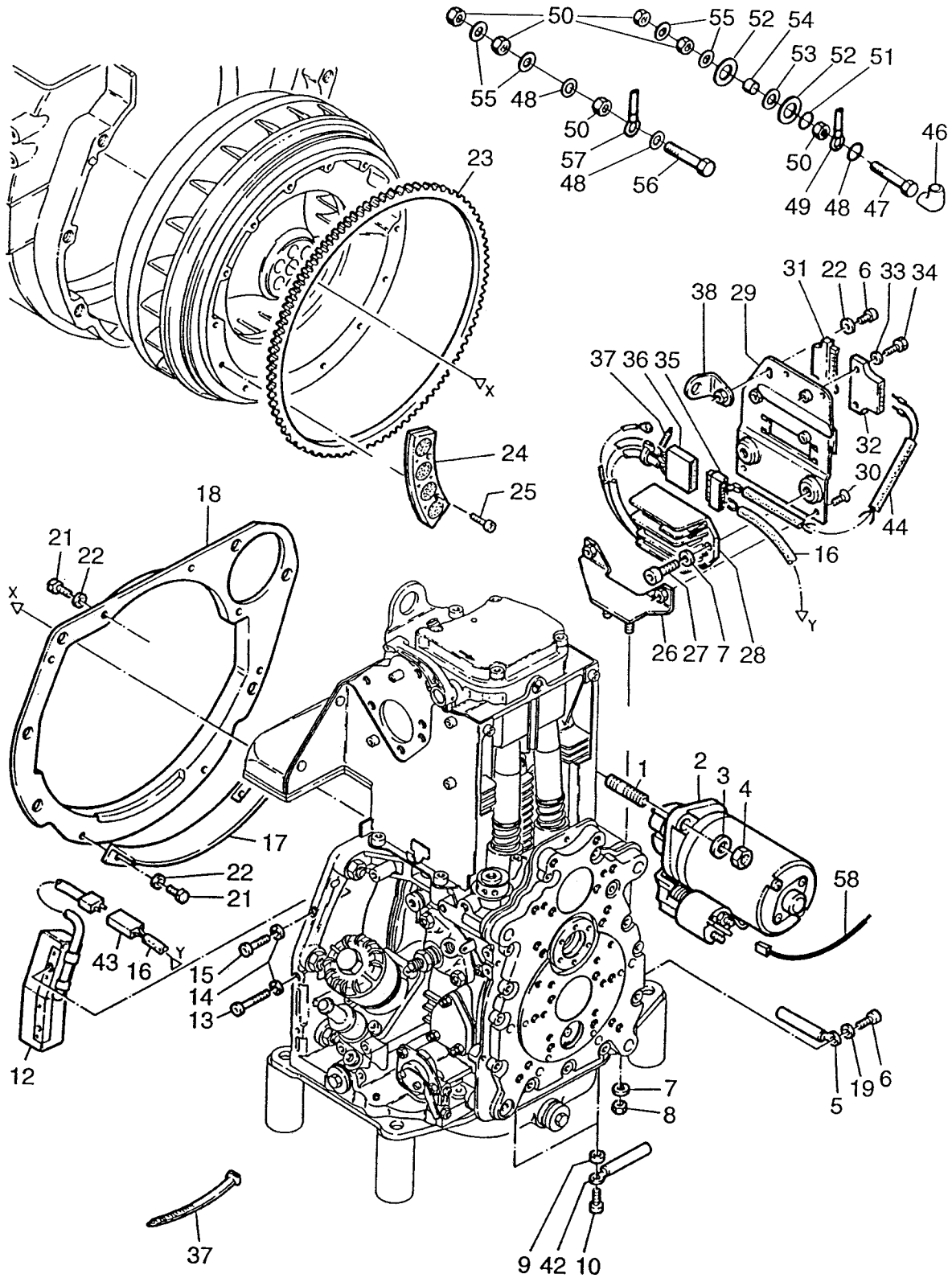



# HATZ 1D81Z ENGINE — STARTER/ALTERNATOR ASSY.

## STARTER/ALTERNATOR ASSY.

<u>NO.</u>	<u>PART NO.</u>	<u>PART NAME</u>	<u>QTY.</u>	<u>REMARKS</u>
1	50201200	STUD M 12 X 50	2	
2	50353420	STARTER 12 V 10 TOOTH	1	
3	50093700	WASHER, FLAT A 13	2	
4	50380600	HEXAGON NUT M 12	2	
5	01459700	CLIP	2	
6	50149100	ALLEN SCREW M 6 X 12	2	
7	50208500	WASHER, LOCK 8	4	
8	50148000	HEXAGON NUT M 8	2	
9	04021000	BUSH 6.3 X 12.15 X 5	2	
10	50170700	ALLEN SCREW M 6 X 16	2	
12	01439000	COIL WITH WIRE 12 V	1	
13	50401200	ALLEN SCREW M 6 X 35	1	
14	50165600	WASHER, LOCK	2	
15	50236600	ALLEN SCREW M 6 X 25	1	
16	01462800	ELECTRIC WIRE	1	
17	04021100	PROTECT. ALTERNATOR	1	
18	04009920	PARTING SHEET	1	
19	50144500	WASHER, FLAT 6.4	1	
21	50165500	HEXSCREW M 6 X 12	5	
22	50170900	WASHER, LOCK 6	6	
23	04021210	GEAR RING 123 TEETH	1	
24	04020421	MAGNET SEGMENT	7	
25	50397100	ALLEN SCREW M 4 X 10	14	
26	01440300	SUPPORT	1	
27	50165400	ALLEN SCREW M 8 X 16	2	
28	01248121	REGULATOR 12 V	1	
28	01425021	REGULATOR 24 V	1	
29	01440100	FASTENING PLATE	1	
30	50380800	CTR. SUNK SCREW M 6 X 10	2	
31	50373700	PLUG SLEEVE HOUSING	1	
32	50373600	PIN TERM. HOUSING 6 WAY	1	
33	50216300	WASHER 5.3	2	
34	50335700	HEXSCREW M 5 X 25	2	
35	50402100	PLUG SLEEVE HOUSING	1	
36	50402000	PLUG SLEEVE HOUSING	1	
37	50358400	STRAP	4	
38	01440200	SUPPORT	1	
42	01470200	CLIP	2	
43	50379700	PLUG SLEEVE HOUSING	1	
44	01439400	WIRING HARNESS	1	
46	40026600	PROTECTION CAP. RUBBER	1	
47	50400300	HEXSCREW M 8 X 40	1	
48	50179900	STAR WASHER	1..2	
49	01430800	BATTERY CABLE PLUS	1	
50	50023000	HEXAGON NUT M 8	3	
51	50426900	SERRATED WASH. A 8.4	1	
52	03814100	INSULATING DISC	2	
53	50426800	TOOTH LOCK J 10.5	1	
54	03814200	INSULATING TUBE	1	
55	50016800	DISC 8.4	2	
56	50275300	HEXSCREW M 8 X 35	1	
57	01430900	BATTERY CABLE MINUS	1	
58	01193401	ELECTRIC WIRE	1	

# HATZ 1D81Z ENGINE — INSTRUMENT BOX ASSY.

## INSTRUMENT BOX ASSY.

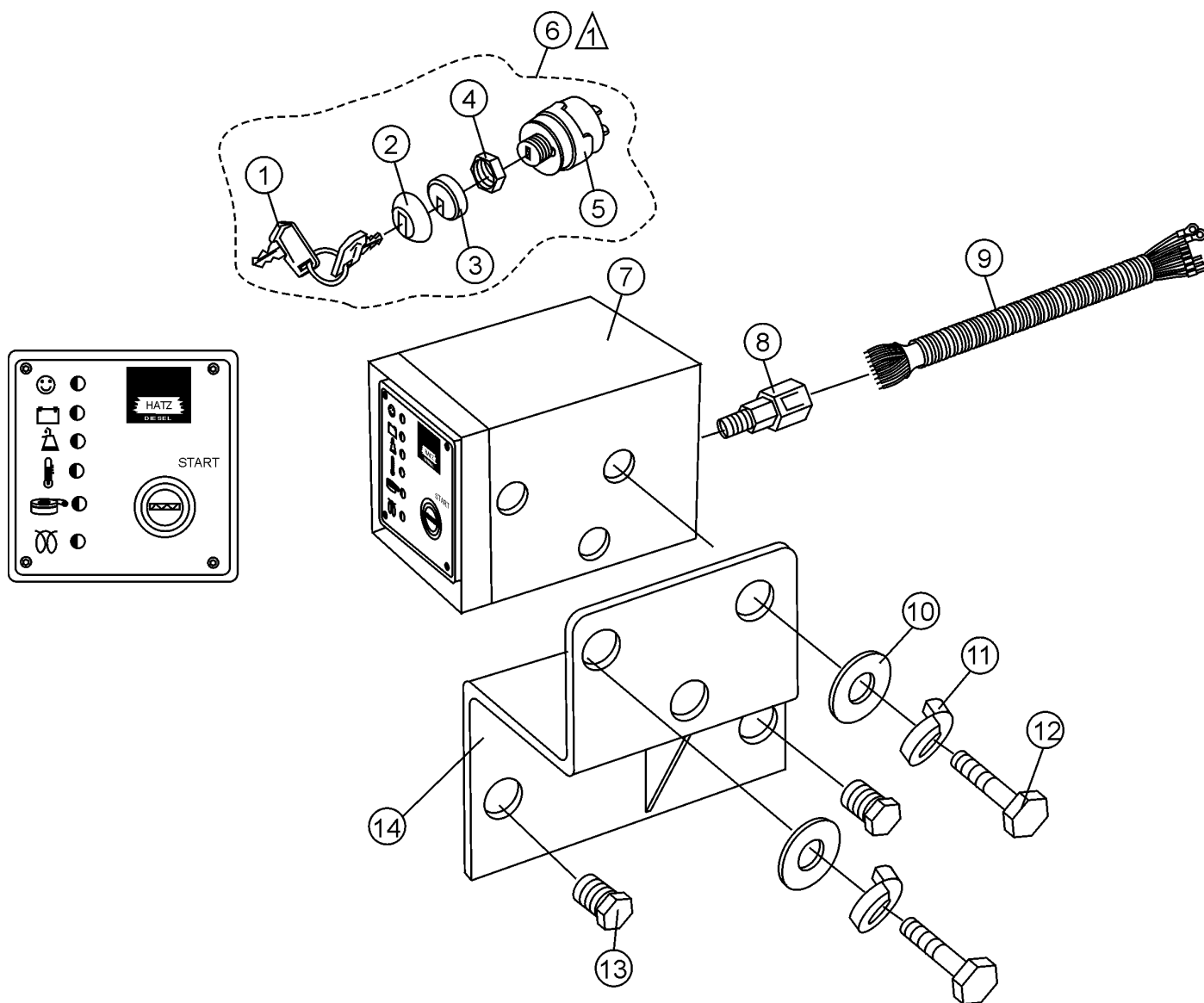

### NOTES:

- ▲ COMPLETE IGNITION SWITCH ASSEMBLY INCLUDES ITEMS WITHIN DASHED LINES.

# HATZ 1D81Z ENGINE — INSTRUMENT BOX ASSY.

## INSTRUMENT BOX ASSY.

<u>NO.</u>	<u>PART NO.</u>	<u>PART NAME</u>	<u>QTY.</u>	<u>REMARKS</u>
1*	50404900	IGNITION KEY	1	
2*	05126402	IGNITION SW. OUTER COVER	1	
3*		IGNITION SW. INNER FLANGE .....	1 .....	CANNOT BE PURCHASED SEPARATELY
4*		IGNITION LOCKNUT .....	1 .....	CANNOT BE PURCHASED SEPARATELY
5*		IGNITION SWITCH .....	1 .....	CANNOT BE PURCHASED SEPARATELY
6	50404900	IGNITION SWITCH ASSY. CP .....	1 .....	INCLUDES ITEMS W/*
7	01558901	INSTR. BOX BOX 12/24 VDC	1	
8	TBD	MALE CABLE COUPLING	1	
9	01433601	WIRING HARNESS	1	
10	952404470	WASHER, FLAT M6 ZINC	3	
11	030206150	WASHER, LOCK 6MM	3	
12	011206020	HEX HEAD SCREW 6X20	3	
13	012210015	BOLT 10X15	2	
14	34581	BRACKET	1	

# HATZ 1D81Z ENGINE — LIFTING MAGNET/STOPDEVICE ASSY.

LIFTING MAGNET/S TOP DEVICE ASSY.

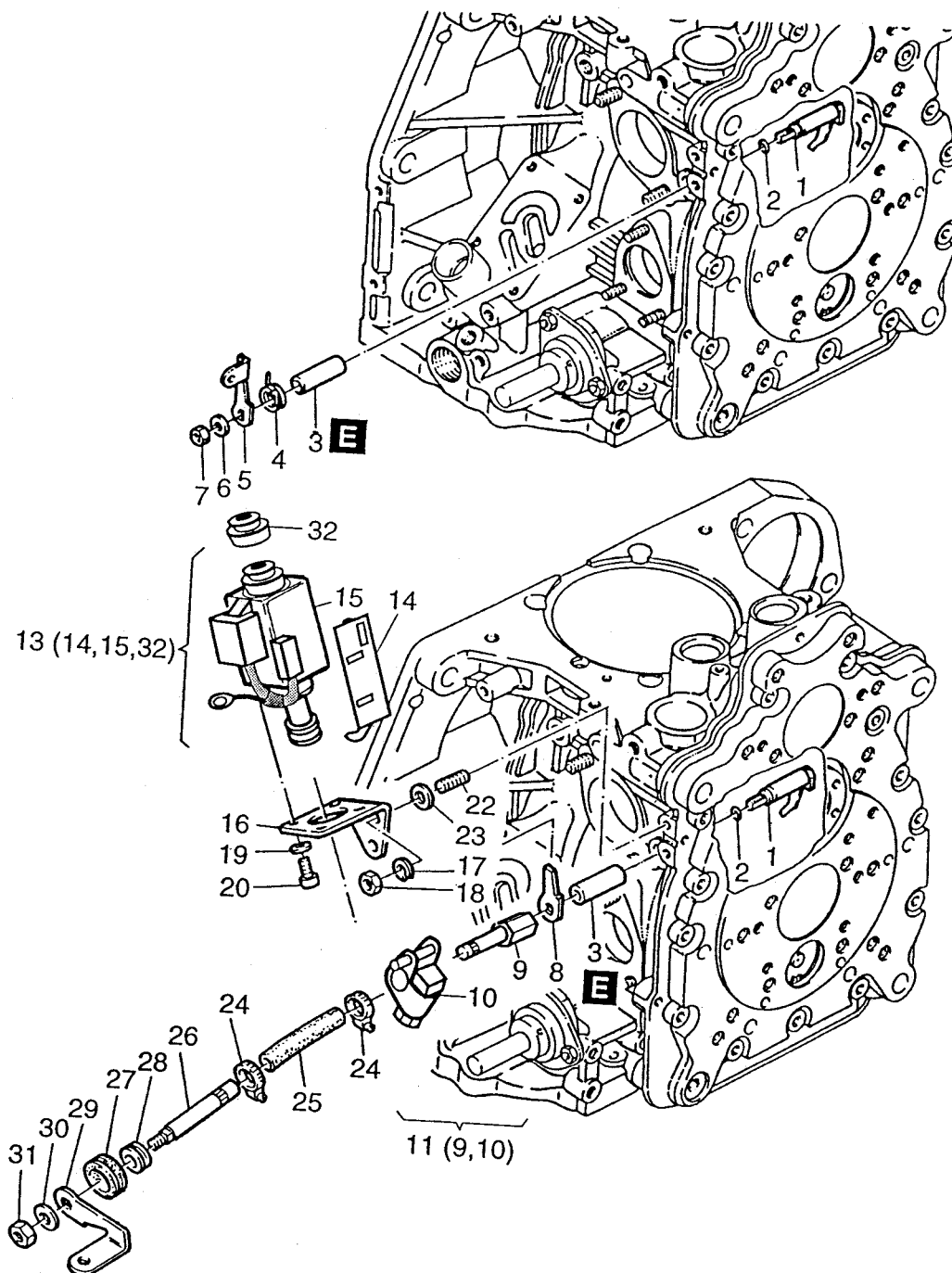

LETTERS IN BOLD INDICATE TYPE OF BONDING ADHESIVE TO BE USED.

D= LOCTITE 221 H= SILICON E= LOCTITE 648

# HATZ 1D81Z ENGINE — LIFTING MAGNET/STOPDEVICE ASSY.

## LIFTING MAGNET/STOP DEVICE ASSY.

<u>NO.</u>	<u>PART NO.</u>	<u>PART NAME</u>	<u>QTY.</u>	<u>REMARKS</u>
1	01254602	LEVER CPL.	1	
2	50343300	O-RING 4.6 X 1.85	1	
3	04021400	BUSH	1	
4	04021800	SPRING	1	
5	04021700	LEVER	1	
6	50144500	WASHER, FLAT 6.4	1	
7	50328300	HEXAGON NUT M 6	1	
8	05015100	SUPPORT SOLENOID	1	
9#		BUSHING .....	1	CANNOT BE PURCHASED SEPARATELY
10#		LINKAGE .....	1	CANNOT BE PURCHASED SEPARATELY
11	01515300	SHAFT + LEVER STOPMAG .....	1	INCLUDES ITEMS W/#
13	01515500	LIFTING MAGNET 12 V .....	1	INCLUDES ITEMS W/*
14*	05058400	CABLE HOLDER	1	
15*		STOP MAGNET .....	1	CANNOT BE PURCHASED SEPARATELY
16	05023501	CONSOLE	1	
17	50170900	WASHER, LOCK 6	2	
18	50144400	HEXAGON NUT M 6	2	
19	50216300	WASHER 5.3	3	
20	50112600	ALLEN SCREW M 5 X 10	4	
22	50366800	STUD M 6 X 12	2	
23	50114300	DISC 6.4	2	
24	40037300	CLAMP 8-12	2	
25	03999001	FUEL HOSE 7/70	1	
26	03996600	SHAFT	1	
27	03565400	RUBBER SLEEVE	1	
28	05069200	BUSH F. BELT TENSION	1	
29	04021700	LEVER	1	
30	50144500	WASHER	1	
31	50328300	HEXAGON NUT M6	1	
32*	50248900	BELLOWS	1	

**PAYMENT TERMS**

Terms of payment for parts are net 10 days.

**FREIGHT POLICY**

All parts orders will be shipped collect or prepaid with the charges added to the invoice. All shipments are F.O.B. point of origin. Multiquip's responsibility ceases when a signed manifest has been obtained from the carrier, and any claim for shortage or damage must be settled between the consignee and the carrier.

**MINIMUM ORDER**

The minimum charge for orders from Multiquip is \$15.00 net. Customers will be asked for instructions regarding handling of orders not meeting this requirement.

**RETURNED GOODS POLICY**

Return shipments will be accepted and credit will be allowed, subject to the following provisions:

1. A Returned Material Authorization must be approved by Multiquip prior to shipment.
2. To obtain a Return Material Authorization, a list must be provided to Multiquip Parts Sales that defines item numbers, quantities, and descriptions of the items to be returned.
  - a. The parts numbers and descriptions must match the current parts price list.
  - b. The list must be typed or computer generated.
  - c. The list must state the reason(s) for the return.
  - d. The list must reference the sales order(s) or invoice(s) under which the items were originally purchased.
  - e. The list must include the name and phone number of the person requesting the RMA.
3. A copy of the Return Material Authorization must accompany the return shipment.
4. Freight is at the sender's expense. All parts must be returned freight prepaid to Multiquip's designated receiving point.

5. Parts must be in new and resalable condition, in the original Multiquip package (if any), and with Multiquip part numbers clearly marked.
6. The following items are not returnable:
  - a. Obsolete parts. (If an item is in the price book and shows as being replaced by another item, it is obsolete.)
  - b. Any parts with a limited shelf life (such as gaskets, seals, "O" rings, and other rubber parts) that were purchased more than six months prior to the return date.
  - c. Any line item with an extended dealer net price of less than \$5.00.
  - d. Special order items.
  - e. Electrical components.
  - f. Paint, chemicals, and lubricants.
  - g. Decals and paper products.
  - h. Items purchased in kits.
7. The sender will be notified of any material received that is not acceptable.
8. Such material will be held for five working days from notification, pending instructions. If a reply is not received within five days, the material will be returned to the sender at his expense.
9. Credit on returned parts will be issued at dealer net price at time of the original purchase, less a 15% restocking charge.
10. In cases where an item is accepted, for which the original purchase document can not be determined, the price will be based on the list price that was effective twelve months prior to the RMA date.
11. Credit issued will be applied to future purchases only.

**PRICING AND REBATES**

Prices are subject to change without prior notice. Price changes are effective on a specific date and all orders received on or after that date will be billed at the revised price. Rebates for price declines and added charges for price increases will not be made for stock on hand at the time of any price change.

Multiquip reserves the right to quote and sell direct to Government agencies, and to Original Equipment Manufacturer accounts who use our products as integral parts of their own products.

**SPECIAL EXPEDITING SERVICE**

A \$35.00 surcharge will be added to the invoice for special handling including bus shipments, insured parcel post or in cases where Multiquip must personally deliver the parts to the carrier.

**LIMITATIONS OF SELLER'S LIABILITY**

Multiquip shall not be liable hereunder for damages in excess of the purchase price of the item with respect to which damages are claimed, and in no event shall Multiquip be liable for loss of profit or good will or for any other special, consequential or incidental damages.

**LIMITATION OF WARRANTIES**

No warranties, express or implied, are made in connection with the sale of parts or trade accessories nor as to any engine not manufactured by Multiquip. Such warranties made in connection with the sale of new, complete units are made exclusively by a statement of warranty packaged with such units, and Multiquip neither assumes nor authorizes any person to assume for it any other obligation or liability whatever in connection with the sale of its products. Apart from such written statement of warranty, there are no warranties, express, implied or statutory, which extend beyond the description of the products on the face hereof.



# OPERATION AND PARTS MANUAL

## **HERE'S HOW TO GET HELP**

PLEASE HAVE THE MODEL AND SERIAL  
NUMBER *ON-HAND* WHEN CALLING

### **MULTIQUIP'S MAIN PHONE NUMBERS**

800-421-1244      FAX: 310-537-3927  
310-537-3700

### **PARTS DEPARTMENT**

800-427-1244      FAX: 800-672-7877  
310-537-3700      FAX: 310-637-3284

### **MAYCO PARTS**

800-306-2926      FAX: 800-672-7877  
310-537-3700      FAX: 310-637-3284

### **SERVICE DEPARTMENT**

800-478-1244      FAX: 310-537-4259  
310-537-3700

### **MQ POWER SERVICE DEPARTMENT**

800-835-2551      FAX: 310-638-8046  
310-537-3700

### **TECHNICAL ASSISTANCE**

800-478-1244      FAX: 310-631-5032

### **WARRANTY DEPARTMENT**

800-421-1244, EXT. 279      FAX: 310-537-1173  
310-537-3700, EXT. 279



**MULTIQUIP INC.**  
POST OFFICE BOX 6254  
CARSON, CA 90749  
310-537-3700 • 800-421-1244  
FAX: 310-537-3927  
E-MAIL: [mq@multiquip.com](mailto:mq@multiquip.com)  
WWW: [multiquip.com](http://multiquip.com)

Atlanta • Boise • Dallas • Houston • Newark  
Quebec, Canada • Manchester, UK • Rio De Janeiro, BR • Guadalajara, MX



manufactured for Multiquip Inc.  
by  
**MIKASA SANGYO CO., LTD. Tokyo, Japan**