

Vitodens 100-W



Gas fired condensing Combination and System boiler, type WB1C, with modulating Matrix cylinder burner and Inox-Radial heat exchanger for open flue and balanced flue operation.

Rated output range: 7.4 to 35 kW

10 Year Warranty

on all stainless steel heat exchangers for
gas condensing boilers up to 105 kW

Contents



Viessmann Headquarters, Allendorf (Eder), Germany

Viessmann profile	from page 2
Product features	from page 6
Control technology	from page 10
Ease of installation	from page 11
Technical specification	from page 14

Leading heating technology from Europe's largest brand - manufactured in Germany's most sustainable factory

Established in 1917, Viessmann draws on more than 90 years of experience in the development and manufacture of heating systems and due to its high commitment to quality, it is Europe's single largest brand in heating technology. Viessmann is a third generation family business and as such is able to hold true to its principles of innovation, efficiency and sustainability; this is a significant reason behind Viessmann's continuing success.

Viessmann's domestic product range has been built around a long established reputation for high quality commercial heating systems. Viessmann has utilised its extensive knowledge and expertise to develop domestic heating products that define the quality benchmark for other brands. Viessmann manufactures all of its own products and controls to ensure that the drive for quality remains throughout the entire range and that there are additional benefits from combining its heating technologies. Viessmann produces and sells products in the following sectors: high efficiency boilers, both domestic and commercial; solar thermal flat plate and tube collectors and PV panels; air source and ground source heat pumps; biomass boilers; and CHP units for commercial and domestic use, using a number of fuels including biogas.

However the principles of innovation, efficiency and sustainability don't only apply to products, but extend to all areas of the business. Viessmann's head office and production facility in Allendorf, Germany, was restructured from 2007 to 2009 at a cost of 220 million Euros and energy use was aligned with European climate change goals, of a 20% reduction in energy usage and CO₂ emissions and a transfer of 20% of energy production into renewables, by 2020. In 2009, under the umbrella of the 'Efficiency Plus' project, Viessmann achieved its goal of saving 40% of oil, gas and electricity through the use of renewable energy while at the same time reducing CO₂ emissions by a third. Almost all measures to improve efficiency and renewable substitution were achieved with commercially available products made by members of the Viessmann Group; whether these were Solar panels, CHP units, Oil, Gas or Biomass boilers.

For this project, Viessmann received the German Sustainability Award 2009 in the category "Most Sustainable Production" as well as the German Energy Agency's Efficiency Award in 2010. In addition, Viessmann was honoured with the 2011 German Sustainability Award in the category "Most Sustainable Brand". These awards recognised the company's achievement of combining economic success with social responsibility and environmental conservation. Hence Viessmann products contribute to reducing the carbon footprint of UK homes even before they are installed.



**Efficiency
Plus**



Viessmann heating equipment: Committed to the environment

Condensing technology offers the greatest potential for conserving fossil fuels in the heating sector.

A crucial element of the EC Directive regarding "integrated pollution prevention and control" (IPPC Directive) of 30th October 1996 is the stipulation to apply the "best available technology" (BAT) in all new systems, and since 2007, also in all existing systems.

Viessmann feels a traditional obligation to the basic requirement of using the best technology available while aiming to protect the environment to the best of its ability. As the generation of heating energy accounts for 40 percent of all European energy consumption, the best technology available for this has a significant influence on resources and environmental protection. The following examples reflect this:

Condensing technology offers the greatest energy utilisation

Condensing technology for oil and gas currently offers the highest energy utilisation with seasonal efficiencies (to DIN) of up to 98 percent. Compared to other technologies for generating heat, this substantially reduces the consumption of fossil fuels. In this process, additional heat is obtained from the flue gas through condensation. This makes particularly high demands of the heating surface material and design. All Viessmann condensing boilers for gas or oil are therefore equipped with stainless steel heating surfaces/heat exchangers.

Fossil oil and gas may only be available for a limited time now, but Viessmann condensing technology is futureproof, because bio-oil and biogas from sustainable materials can gradually replace crude oil and natural gas. Today, all Viessmann condensing boilers are already prepared for admixtures of bio-oil and biogas.

Weather Compensation – Great for gas bills

With the increasing cost of fuel, boiler efficiency is becoming more and more important. The only way to improve the efficiency of a good quality condensing boiler is to add weather compensation controls.

The Vitodens 100-W range are designed to work with optional weather compensation controls, to achieve additional fuel savings of up to 12% – meaning huge savings every year, for a small initial outlay (System models must be installed as a 4-pipe system).

The controls work by monitoring the outside air temperature and adjusting the heating water from the boiler to suit. Lower flow and return temperatures mean that the boiler can condense more. This proactive mechanism means that the boiler burns as much fuel as it needs – but no more – to achieve the desired room temperature.

People inside the building will experience a constant temperature and won't even notice that the temperature outside has changed – but they will notice a significant reduction of their gas bills!

Good news for architects and specifiers – the weather compensation feature adds 3% to the boiler's SEDBUK efficiency when using SAP (Standard Assessment Procedure).

To understand more about the benefits of weather compensation and how it works, download our Weather Compensation brochure from www.viessmann.co.uk

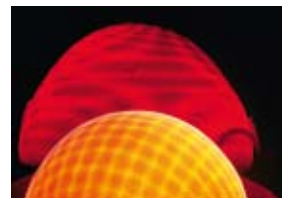
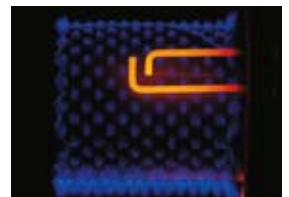

The MatriX cylinder burner and MatriX burner (bottom) ensure maximum energy efficiency and extremely clean combustion.



**Efficient, durable,
affordable and quiet**



VITODENS 100-W

Looking for a modern gas fired condensing boiler with a particularly favourable price - without sacrificing quality?

With the Vitodens 100-W, we have the solution. With a range of models and outputs to suit every application.

Vitodens 100-W product info at a glance

Vitodens 100-W System boiler:

19, 26, 30 and 35 kW
Standard efficiency:
97% (Hs) / 108% (Hi)*

Vitodens 100-W Combination boiler:

26, 30 and 35 kW
Standard efficiency:
97% (Hs) / 108% (Hi)*

Reliable and durable - Made in Germany

As a major manufacturer, with many years of experience in the manufacture of wall mounted boilers we know what matters. Even when attractively priced, our standards of product quality and performance are consistently implemented. Therefore Viessmann wall hung boilers are not only renowned for innovative technology and services, but particularly for reliability and longevity.

Warranties

- 5 year comprehensive parts and labour warranty on the boiler
- 10 year warranty on the unique Viessmann Inox-Radial heat exchanger

10 Year Warranty

on all stainless steel heat exchangers for gas condensing boilers up to 105 kW

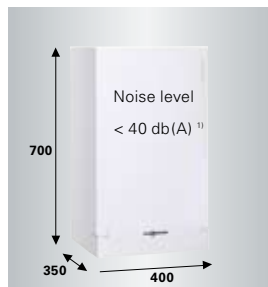

One of the smallest and quietest gas fired wall hung boilers in this product group

The compact dimensions and minimal operating noise mean it can be easily integrated into the smallest of homes.

¹¹ 35 kW output

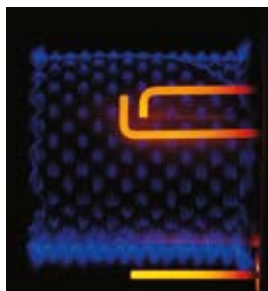

Long service life through stainless steel MatriX mesh

The MatriX cylinder burner developed and produced by Viessmann ensures high efficiency because of its stainless steel MatriX mesh.

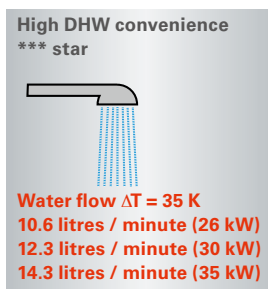

High DHW convenience

The electronic temperature regulator ensures a constant supply of DHW.



Service and maintenance

The AquaBloc combines all hydraulic components into one compact unit, to make all serviceable parts easily accessible from the front of the boiler, cutting down on servicing time and cost.

* (Hs) = gross calorific value
(Hi) = net calorific value

Vitodens 100-W

Product features - The Inox-Radial heat exchanger and how it works

In 1995 Viessmann developed the Inox-Radial stainless steel heat exchanger. At the heart of all Vitodens wall-mounted condensing boilers is a corrosion-resistant, high-alloy stainless steel Inox-Radial heat exchanger. A key component to outstanding efficiency, this high performance heat exchanger also delivers proven reliability and a long service life.

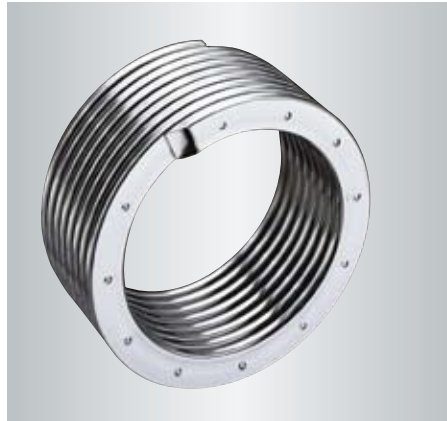

Inox-Radial heat exchanger

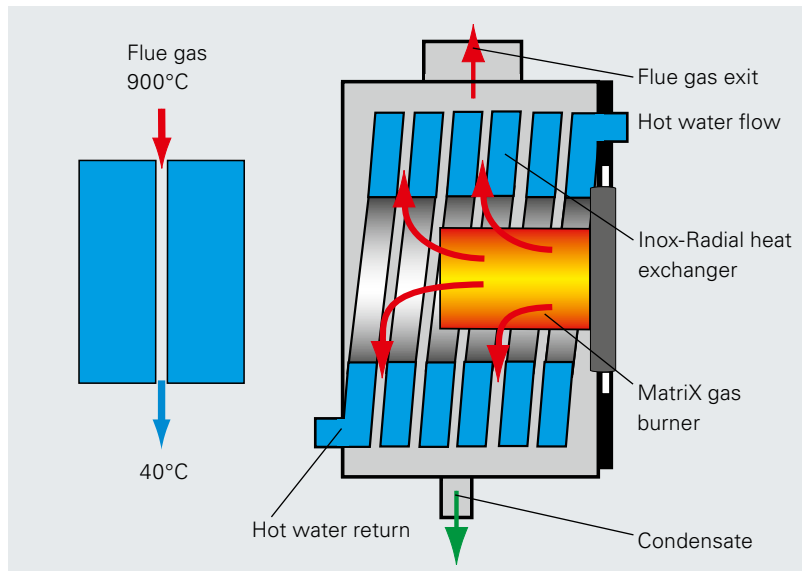

The heat exchanger in operation



The Inox-Radial heat exchanger is manufactured in Allendorf, Germany

The heat exchanger design

Stainless steel is, without doubt, the best material for primary heat exchangers in condensing boilers. One of the unique design features of all Vitodens boilers is the Inox-Radial heat exchanger made from high grade stainless steel. Designed for long-term reliability, high performance and self cleaning. We are so confident in our heat exchanger that we guarantee it for 10 years against corrosion.

Innovative technology and high quality materials

Stainless steel is used in many demanding applications including medical technology and aerospace. When stainless steel is combined with innovative design there are significant benefits in durability and reliability.

100% corrosive resistant - one of the many advantages of stainless steel

Stainless steel is ideally suited to condensing boilers. It is temperature stable and resistant to condensate, making it very corrosion resistant and extremely durable.

Excellent self-cleaning depends on a smooth surface

The smooth surface of stainless steel is perfect for condensing boilers. Viessmann builds on this advantage by designing heating surfaces which enhance the self-cleaning effect. This means the condensate drains off more quickly. Dirt and residues of combustion cannot take hold, resulting in considerable savings in maintenance, the certainty of long term high efficiency, reliability and increased product life.

Maximum energy from minimum space

Small in size, big on performance. Efficient transfer of the heat from the heating gas to the water depends on the heating gas being in extremely close contact with the heating surface. Viessmann has developed special technologies for this very purpose, such as the Inox-Radial heating surface used in wall-mounted boilers.

The Inox-Radial heat exchanger is the result of intensive development

Heat transfer in the Inox-Radial heat exchanger takes place across a laminar split flow. Instead of a round section stainless steel pipe, Viessmann has developed a rectangular stainless steel spiral wound heat exchanger. A slot of 0.8mm is maintained across the total length and this produces a laminar flow without a boundary layer - and excellent heat transfer.

Product features - The MatriX cylinder burner



The MatriX burner is a milestone

The MatriX cylinder burner, in combination with the Inox- Radial heat exchanger, ensures high-energy efficiency and long-term heating convenience. Plus, with low emission combustion, the MatriX cylinder burner is also environmentally-friendly.



MatriX cylinder burner

Modulating MatriX pre-mix burner

Developed by Viessmann, with thousands of tiny flames instead of one large flame, the MatriX cylinder burner distributes heat cleanly and efficiently and the stainless steel MatriX mesh ensures long term reliability.

The extremely low NOx and CO emissions meet or exceed all international clean air regulations and guidelines. With a modulation range of 1:4 the heat demand is optimised and maximum efficiency levels are achieved.

The MatriX cylinder burner was developed and manufactured by Viessmann in 1994 and due to the extremely low emissions the innovation was awarded the Business Award for the Environment. 1.5 million MatriX burners have been manufactured to date.

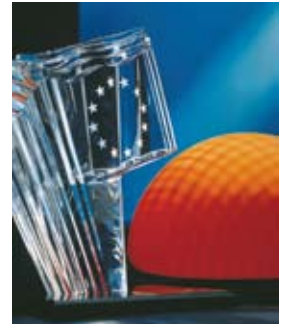

1994 European Business Award for the Environment

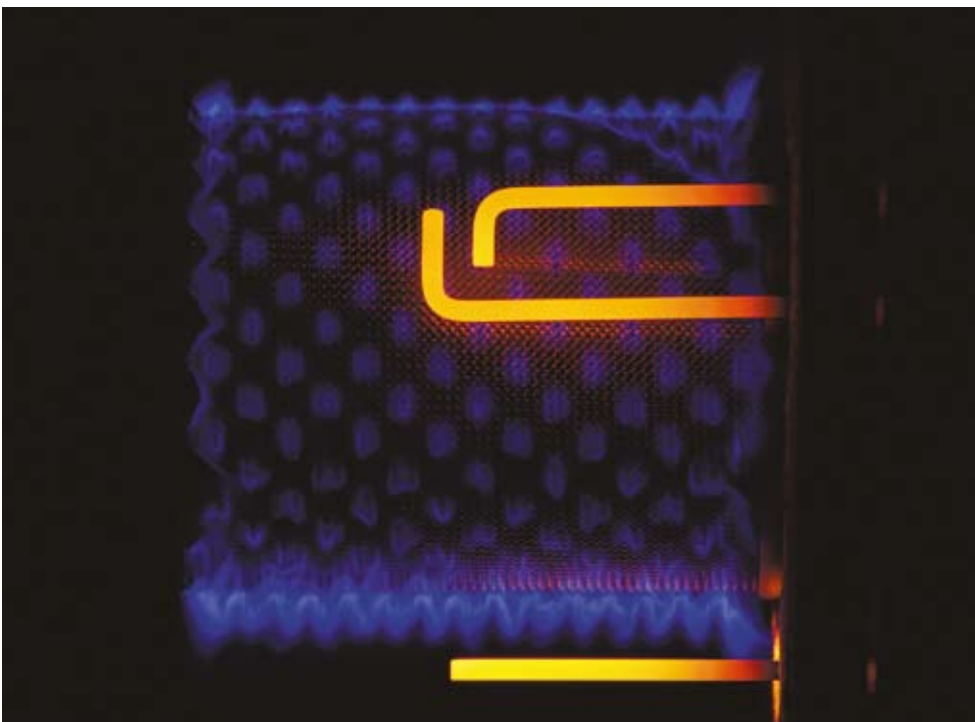

MatriX burner in operation



- 1 Pressure gauge
- 2 LCD display
- 3 Dial for water temperature
- 4 Dial for central heating / weather compensation adjustment
- 5 On/off button with reset function
- 6 Interchangeable panel for the installation of the Vitotrol 100 UTD-RF2 receiver / UTA-RF1 receiver / plug-in clock

Simply the best: the functions of the controller

All functions are easily operated by hand

Ease of use

All functions are easily operated by hand. The user-friendly dials allow for fast adjustment of the heating and domestic hot water temperature. The LCD display shows the temperature settings.

Plug in clocks

Analogue plug-in clock for operation with Vitotrol 100 room thermostat. Single channel for heating, 24 hour.

Digital plug-in clock for operation with Vitotrol 100 room thermostat. Two channel for heating and DHW, 7 day.



Vitotrol 100 room thermostat



Vitotrol 100 UTDB



Vitotrol 100 UTDB-RF2



Vitotrol 100 UTA-RF1

Functions of the controller

The Vitodens 100-W is supplied with a control unit, featuring a built-in diagnostics system and frost protection. When connected to an outdoor temperature sensor the boiler switches automatically to the weather compensation mode. The dials are easy to operate and enable fast adjustment of the heating and DHW temperature.

Weather Compensation

Weather compensation controls are a great, low cost way to make a boiler operate more efficiently. They can save up to 12% of annual fuel bills with the Vitodens 100-W – that's on top of the big savings that you get from changing to a condensing boiler. This must be used in conjunction with an outdoor temperature sensor (accessory).

Remote control of the heating system from your living room

The Vitodens 100-W can be controlled by wired or wireless remote controls

- **Vitotrol 100 room thermostat**
Basic room thermostat with switched output (two-point output)
- **Vitotrol 100 UTDB**
Programmable room thermostat - 7 day single channel (wired)
- **Vitotrol 100 UTDB-RF2**
Plug-in programmable room thermostat, 2 channel - 7 day (wireless)
- **Vitotrol 100 UTA-RF1**
Plug-in programmable room thermostat 1 channel, 24 hours (wireless)

Ease of installation : Optional accessories for commissioning

Pre-plumbing jig (optional accessory)

To help installation of the Vitodens 100-W, all connections are checked for leaks during the assembly process and only need to be tested again once the boiler is hung.

To complete the overall look of the installation a boiler fittings cover is included.

- 1 Pre-plumbing jig with 2 cross bars
- 2 Valve/fittings cover



Rear pipework mounting frame (optional accessory)

The mounting frame has the same benefits as the pre-plumbing jig but with the ability to allow 50 mm behind the frame for wiring upwards behind the unit.

To complete the overall look of the installation a boiler fittings cover can also be included.

- 1 Rear pipework mounting frame with 2 cross bars
- 2 Valve/fittings cover



Easy commissioning and maintenance

1. Installation with pre-plumbing jig
2. Mounting the boiler
3. Electrical connection
4. Commissioning

With a few simple steps the Vitodens 100-W can be installed and operating.

The Vitodens 100-W gas fired condensing boilers are consistently designed for simple installation and time saving servicing.



1. Installation with pre-plumbing jig



2. Mounting the boiler



3. Electrical connection



4. Commissioning

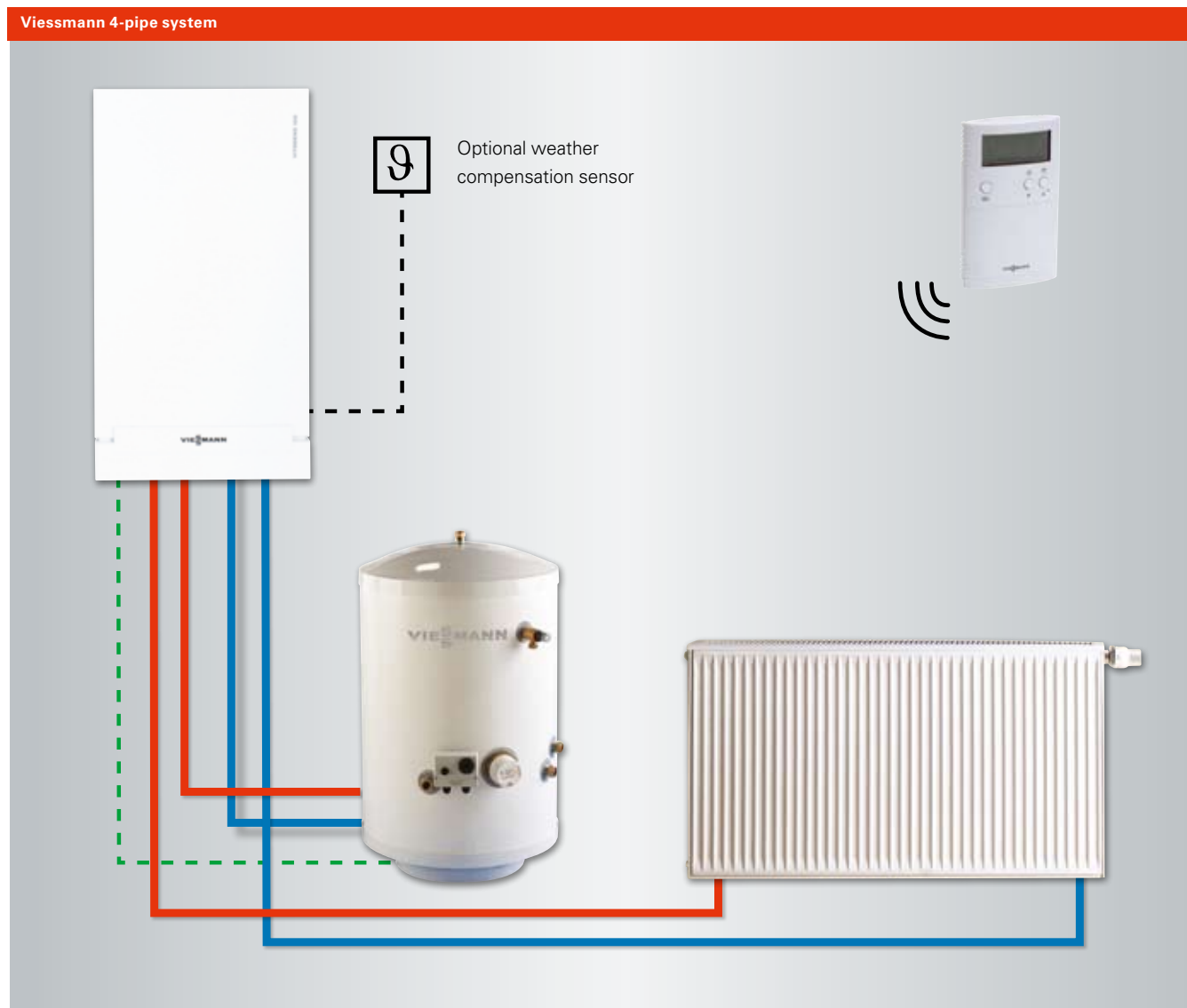

Viessmann Vitodens system boilers up to 35 kW installed together with a Vitocell 200 or 300 unvented cylinder are the perfect combination to meet G3 building regulations without the need for an energy cut-off valve and cylinder overheat thermostat; these are now built into the boiler.

Installation time will be reduced by up to 1 day as the following are no longer required:

- Energy cut off valve or safety valve
- Expansion vessel and pump
- Gauge and cylinder overheat thermostat
- Part P certification

Compatibility with solar

As a manufacturer of the full range of renewable energy technologies all Viessmann boilers are 100% compatible with solar thermal panels. The Vitodens 100-W has the added advantage of boiler suppression, when using Viessmann solar panels and a dual coil cylinder. This means that the hot water system will always take advantage of solar power, whenever solar energy is available and the boiler will only fire to 'top up' the heating process when absolutely necessary – resulting in significant fuel savings.

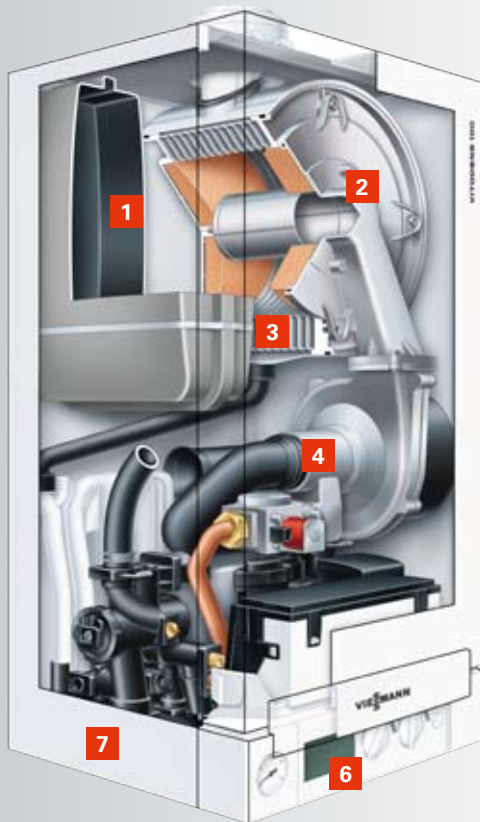

System boiler

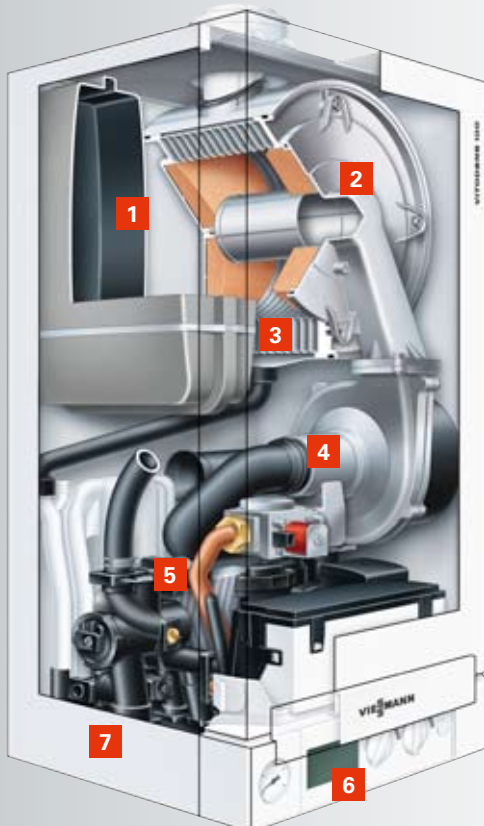

Combination boiler

Vitodens 100-W from 7.4 to 35 kW

- 1 8 litre expansion vessel
- 2 Modulating Matrix cylinder burner for permanently low emissions
- 3 Inox-Radial stainless steel heat exchanger - for high reliability and long service life
- 4 Modulating fan with air intake tube for low noise and low power operation
- 5 Large capacity plate to plate heat exchanger for convenient DHW heating (with combination boiler)
- 6 Controller with integrated diagnostics system
- 7 Combined PRV and condensate connection

Features and benefits summary

- Same output for Heating and Hot Water (up to 35 kW)
- Combined PRV and condensate connection, saving time and expense
- Improved installation options with max. flue length up to 19 metres
- New 19 kW system boiler
- New case design improves service accessibility and reduces noise and weight
- Integral filling loop
- Range rate CH to 25% of maximum output and match output to meet Building Regulations
- Simple conversion to LPG
- Grundfos AquaBloc
- 5 year comprehensive warranty for parts and labour

Dimensions

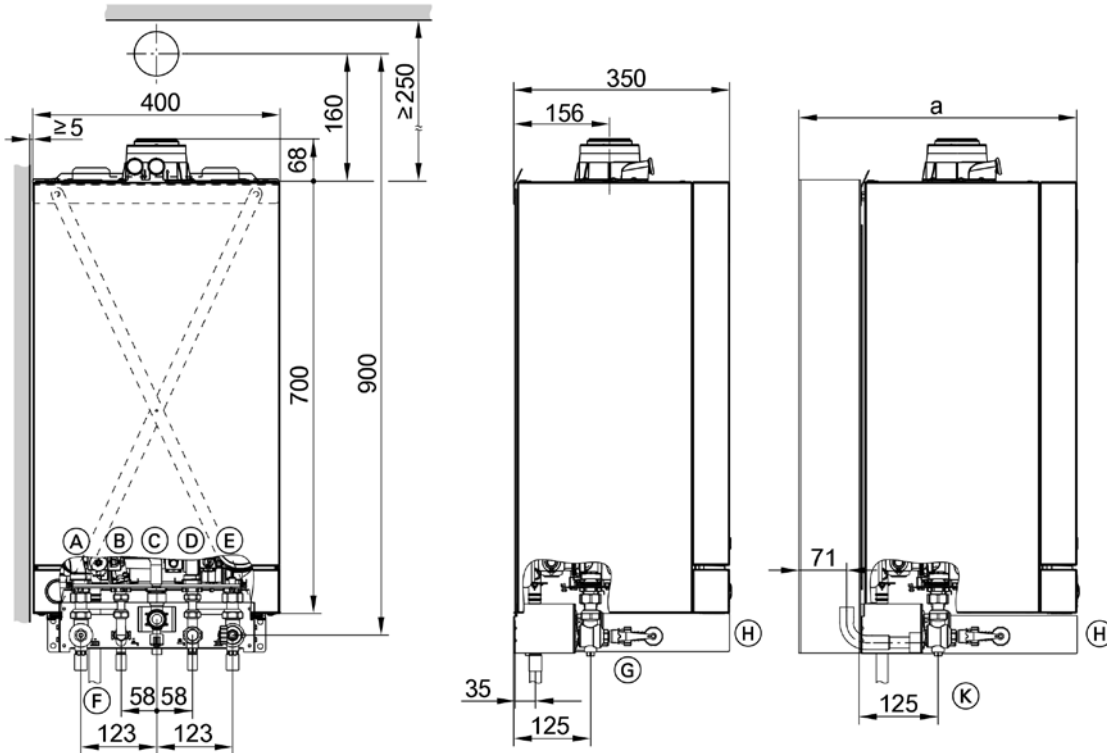

- (A) Heating flow \varnothing 22 mm
- (B) Gas fired condensing boiler:
Cylinder flow G $\frac{3}{4}$
Gas condensing combi boiler:
Hot water 15 mm
- (C) $\frac{3}{4}$ gas connection G
- (D) Gas condensing boiler:
Memory return G $\frac{3}{4}$
Gas condensing combi boiler:
Cold water \varnothing 15 mm
- (E) Heating return \varnothing 22 mm
- (F) Drain / drain safety valve:
Tube \varnothing 22 mm
- (G) Pre-plumbing jig and fittings
- (H) Valve/fittings cover
- (K) Mounting frame and fittings

Dimensions

- With a stand off frame

mm

400

Circulating pump

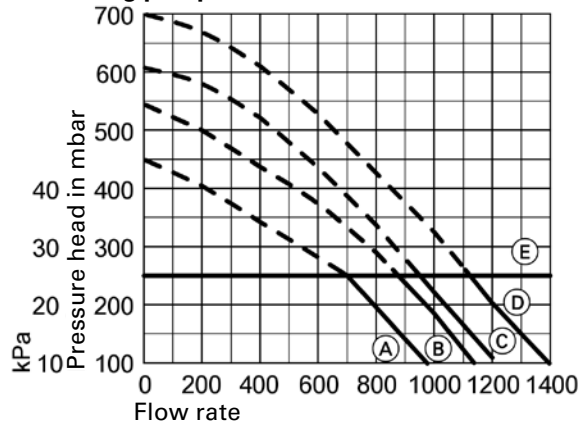

- (A) Gas fired System boiler, 19 kW
- (B) Gas fired System boiler, 26 kW
- (C) Gas fired Combination boiler, 26 kW
- (D) Gas fired System and Combination boiler, 35 kW
- (E) Maximum operating range

Model WB1C		System				Combination		
Mode	Unit	19	26	30	35	26	30	35
Rated CH Output								
At Tf/Tr 50/30 °C (condensing)	kW	6.5 - 19	6.5 - 26.0	8.8 - 30.0	8.8 - 35.1	6.5 - 26.0	8.8 - 30.0	8.8 - 35.00
At Tf/Tr 80/60 °C (non-condensing)	kW	5.9 - 17.3	5.9 - 23.7	8.0 - 26.6	8.0 - 31.1	5.9 - 23.7	8.0 - 26.6	8.0 - 35.0
Rated Central Heating Input (net)	kW	6.1 - 17.8	6.1 - 24.3	8.2 - 27.9	8.2 - 32.8	6.1 - 24.3	8.2 - 27.9	8.2 - 32.7
Rated Central Heating Input (gross)	kW	7.7 - 19.8	7.7 - 27.0	9.1 - 30.9	9.1 - 36.4	7.7 - 27.0	9.1 - 30.9	9.1 - 36.4
Domestic Hot Water Output range	kW	-	-	-	-	6.7 - 26.0	8.0 - 30.0	8.0 - 35.0
Max. Nat gas rate (CH mode)	m ³ /h	1.9	2.6	3	3.5	2.6	3	3.5
Max LPG	kg/H	1.4	1.9	2.2	2.6	1.9	2.2	2.6
Max. Nat gas rate (DHW mode)	-	-	-	-	-	2.9	3.3	3.9
Gas Supply pressure								
Natural gas		20	20	20	20	20	20	20
LPG		37	37	37	37	37	37	37
Max Permissible gas supply Pressure								
Natural gas		25	25	25	25	25	25	25
LPG		45	45	45	45	45	45	45
Efficiency/Emissions								
Full load 100%	%	88.2	88.3	88.3	88.2	88.3	88.3	88.2
Part load 30%	%	97.9	97.9	97.5	98.5	97.9	97.5	98.5
Seasonal Efficiency (SEDBUK)	%	90.3	90.3	90.4	90.3	90.2	90.3	90.2
SEDBUK rating	A	A	A	A	A	A	A	A
NOx classification	class	5 (<39 mg/kWh)	5 (<39 mg/kWh)	5 (<39 mg/kWh)	5 (<39 mg/kWh)	5 (<39 mg/kWh)	5 (<39 mg/kWh)	5 (<39 mg/kWh)
DHW/CH								
DHW performance @ 35°C temp. rise	l/min	-	-	-	-	10.6	12.3	14.3
DHW temp. range	°C	-	-	-	-	30-60	30-60	30-60
Maximum mains water inlet pressure	bar	-	-	-	-	10	10	10
Min. mains water inlet pressure for max DHW heat output	bar	-	-	-	-	1	1	1
Minimum mains water inlet pressure for operation	bar	-	-	-	-	0.5	0.5	0.5
Minimum DHW flow rate for operation	l/min	-	-	-	-	0.5	0.5	0.5
Minimum CH system pressure - cold	bar	0.5	0.5	0.5	0.5	0.5	0.5	0.5
Maximum CH system pressure - hot	bar	3	3	3	3	3	3	3
Cylinder Capacity	l	-	-	-	-	-	-	-
CH flow temp. range	°C	30-80	30-80	30-80	30-80	30-80	30-80	30-80
General specification								
Integral expansion vessel capacity	ltr	8	8	8	8	8	8	8
Integral expansion vessel pre-charge pressure	bar	0.75	0.75	0.75	0.75	0.75	0.75	0.75
Max CH system water content using fitted expansion vessel, @ 0.75bar and 80°C	ltr	125	125	125	125	125	125	125
Total water capacity	ltr	2.8	2.8	3.4	3.4	2.8	3.4	3.4
Lift weight	kg	35	36	37	37	36	38	38
Total weight (incl packaging)	kg	37	38	39	39	38	40	40
Electricity supply		230v 50 HZ	230v 50 HZ	230v 50 HZ	230v 50 HZ	230v 50 HZ	230v 50 HZ	230v 50 HZ
Internal fuse	A	2.5	2.5	2.5	2.5	2.5	2.5	2.5
Maximum power consumption	W	102	107	106	154	119	134	154
Water protect. rating		IP X4D	IP X4D	IP X4D	IP X4D	IP X4D	IP X4D	IP X4D
Flue temp. @50/30 - max CH output	°C	45	45	45	45	45	45	45
Flue temp. @50/30 - min CH output	°C	35	35	35	35	35	35	35
Flue temp. @80/60 - max CH output	°C	68	68	68	70	68	68	70
Flue products mas flow rate - NG - max CH output	kg/h	30.1	41.1	49.0	56.9	41.1	49.0	56.9
Flue products mas flow rate - NG - min CH output	kg/h	14.6	14.6	17.6	17.6	1.6	17.6	17.6
Flue products mas flow rate - LPG - max CH output	kg/h	34	46.4	54.0	62	46.4	54.0	62
Flue products mas flow rate - LPG - min CH output	kg/h	15.9	15.9	19.4	19.4	15.9	19.4	19.4
Gas council number		41-819-26	41-819-27	41-819-28	41-819-29	47-819-20	41-819-21	41-819-22
Product ID		CE-0085 BT0029	CE-0085 BT0029	CE-0085 BT0029	CE-0085 BT0029	CE-0085 BT0029	CE-0085 BT0029	CE-0085 BT0029
Dimens./Connect.								
Inner flue duct diameter	mm	60	60	60	60	60	60	60
Outer flue duct diameter	mm	100	100	100	100	100	100	100
Boiler dimension H x W x D	mm	700 x 400 x 350	700 x 400 x 350	700 x 400 x 350	700 x 400 x 350	700 x 400 x 350	700 x 400 x 350	700 x 400 x 350
DHW outlet & inlet	mm	22	22	22	22	15	15	15
CH flow & return	mm	22	22	22	22	22	22	22
Condensate & SV outlet combined	mm	22	22	22	22	22	22	22
Gas	mm	22	22	22	22	22	22	22
Max. flue length (BF) horizontal/vertical	m	19	13.5	13.5	17	13.5	13.5	17

* The burner output has to be matched to the flue system, please observe the installation instructions.

Flue applications

Vitodens boilers can be installed in virtually all domestic applications, some examples are illustrated.

The maximum flue length is the single biggest consideration. Maximum flue lengths are provided and have already allowed for 2 bends of 87° (including support bends). For each additional 90° elbow reduce the maximum flue length by 1 m, each additional 45° elbow by 0.5 m.

For concentric or balanced flue systems the max. flue length can be up to 19 m. To match the boiler output to the flue system length, a concentric factor has to be set - see installation instructions.

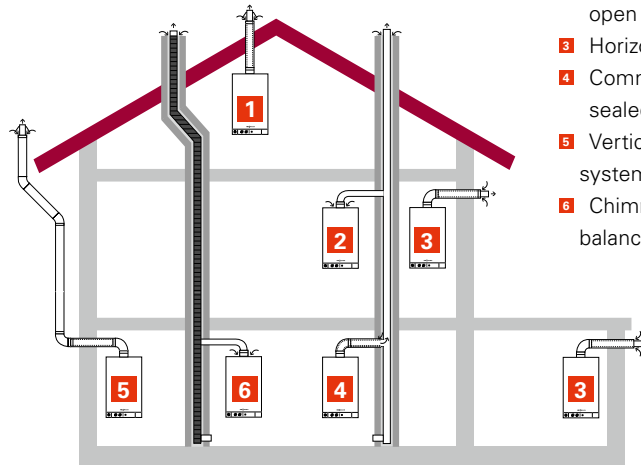

- 1 Vertical, concentric roof terminal – flat and pitched
- 2 Communal flue system – open flued
- 3 Horizontal concentric
- 4 Communal room sealed chimney
- 5 Vertical outside wall system
- 6 Chimney flue (open flued/ balance) with flexible duct

1 Vertical outlet for sloping or flat roofs

Part no.	60/100	80/125
1 Boiler flue connection		
2 Balanced flue roof outlet		
Black	7373230	7373271
Terracotta	7373231	7373272
3 Universal roof tile		
Lead Free Flashing Black	7452499	7452501
Lead Free Flashing Terracotta	7452500	7452502
or Flat roof collar	7248017	7248017
4 Balanced flue inspection piece, straight (optional)	7373228	7199781
5 Balanced flue sliding coupling (optional)	7373236	7194329
Balanced flue bend		
87°	7373226	7194323
2 x 45°	7373227	7194324
Balanced flue pipe		
1 m long	7373224	7194321
0.5 m long	7373223	7194320
Fixing clamp	7176762	7176664

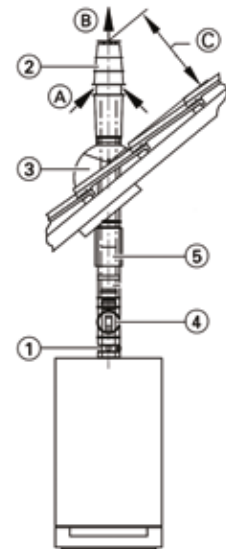

- (A) Ventilation air
- (B) Flue gas
- (C) (min.) 400 mm

3 Horizontal wall terminal

Part no.	60/100	80/125
1 Boiler flue connection		
2 Balanced flue external wall connection (incl. wall bezels)	7441467	7435862
3 Protective grille	7189821	7189821
4 Balanced flue extension pipe		
1 m long	7373224	7194321
0.5 m long	7373223	7194320
5 Balanced flue bend		
87°	7373226	7194323
2 x 45°	7373227	7194324
Fixing clamp	7176762	7176664
Horizontal flue terminal kit	Z009350	
Flue terminal 1 m, 2 x wall seals, balanced flue bend 87°		

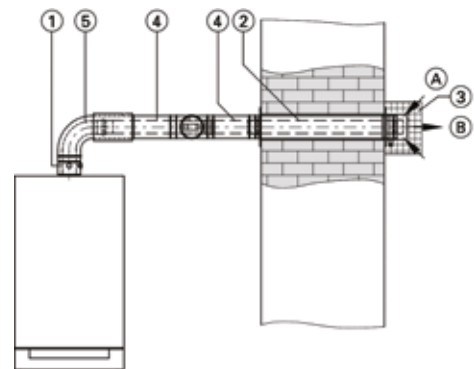

- (A) Combustion air
- (B) Flue gas

6 Balanced flue operation

Part no.	60/100	80/125
① Boiler flue connection		
② Standard shaft pack (PPS, flexible) comprising: <ul style="list-style-type: none"> ■ Support bend ■ Support rail ■ Shaft cover (PPS) ■ Spacers (5 pce.) or Standard shaft pack (metal/PPS, rigid) For twin flue chimneys (one flue for solid fuel boilers). comprising: <ul style="list-style-type: none"> ■ Support bend ■ Support rail ■ Shaft cover (metal) ■ Terminal pipe (stainless steel) ■ Spacers (5 pce.) 	7248206	7248213
③ Spacers (5 pce)	7190560	7147035
③ Flexible pipe , on a roll, 12.5 m long.	7248208	7248216
③ Flexible pipe , on a roll, 25 m long.	7248207	7248215
④ Connecting piece , for connecting residual lengths of the flexible flue pipe.	7248211	7248219
④ Pipe lowering attachment incl. 20 m rope.	7248212	7248214
⑤ Inspection piece , straight For installation in the flexible flue pipe.	7248210	7248218
⑥ Balanced flue inspection piece , straight.	7373228	7199781
⑦ Wall bezel	7176760	7176662
⑧ Balanced flue pipe 1 m long.	7373224	7194321
⑧ Balanced flue pipe 0.5 m long.	7373223	7194320
⑨ Balanced flue bend 87°	7373226	7194323
Chimney flue kit (12.5 m) comprising: parts 2, 3, 7, 8, 9	ZK00029	ZK00031

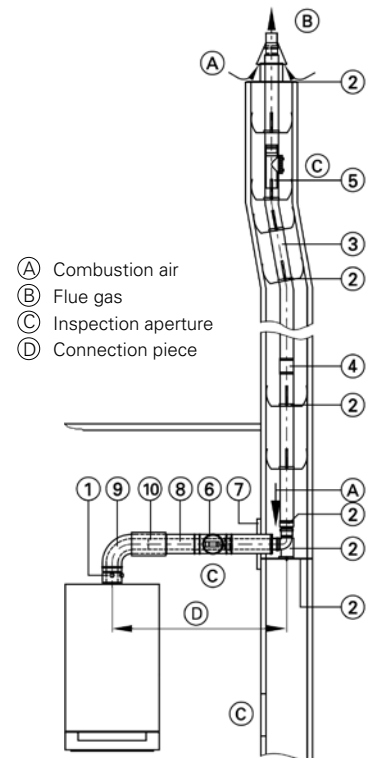

2 Open flue operation

Part no.	60/100	80/125
① Boiler flue connection		
② Standard shaft pack (PPS, flexible) comprising: <ul style="list-style-type: none"> ■ Support bend ■ Support rail ■ Shaft cover (PPS) ■ Spacers (5 pce.) or Standard shaft pack (metal/PPS, rigid) For twin flue chimneys (one flue for solid fuel boilers). comprising: <ul style="list-style-type: none"> ■ Support bend ■ Support rail ■ Shaft cover (metal) ■ Terminal pipe (stainless steel) ■ Spacers (5 pce.) 	7248206	7248213
③ Spacers (5 pce)	7190560	7147035
③ Flexible pipe , on a roll, 12.5 m long.	7248208	7248216
③ Flexible pipe , on a roll, 25 m long.	7248207	7248215
④ Connecting piece , for connecting residual lengths of the flexible flue pipe.	7248211	7248219
④ Pipe lowering attachment incl. 25 m rope.	7248212	7248214
⑤ Inspection piece , straight For installation in the flexible flue pipe.	7248210	7248218
⑥ Inspection piece , straight	7248216	7248312
⑦ Vent bezel	7176728	7176634
⑧ Pipe 1 m long	7373214	7194310
⑧ Pipe 0.5 m long	7373215	7194311
⑨ Bend 87°	7373218	7194314
⑨ Bend 45° (2 pce)	7373219	7194315
or Inspection tee 87°	7373217	7194313
Stainless steel extension for shaft cover 380 mm long (metal/PPS, rigid)	7373278	7373278
Chimney flue kit (12.5 m) comprising: parts 2, 3, 7, 8, 9	ZK00029	ZK00031

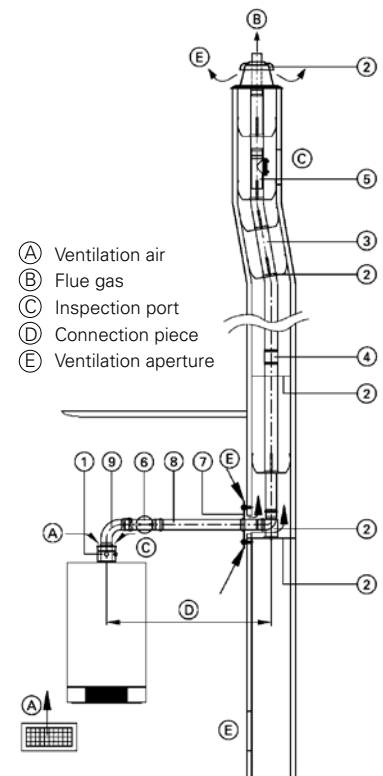

Statutory requirements

The appliance is suitable only for installation in GB and IE and should be installed in accordance with the rules in force. In GB a Gas Safe Registered Installer must carry out the installation. It must be carried out in accordance with the relevant requirements of the:

Gas safety (installation and use) regulations (current issue)

It is in your own interest and safety to ensure that the law is complied with.

In addition to the above regulations, this appliance must be installed in accordance with the current IEE Wiring regulations for electrical installation (BS 7671), local Building Regulations, the Building Standards (Scotland) (Consolidation) Regulations, bye laws of the local water undertaking and Health and Safety Document NO. 635, 'The Electricity at Work regulations 1989'. In Ireland (IE), the installation must be carried out by a Competent Person and installed in accordance with the current edition of I.S.813 "Domestic Gas Installations", the current Building Regulations and references should be made to the current ETCl rules for electrical installation.

It should also be in accordance with the relevant recommendations in the current editions of the following British Standards and Codes of Practice: BS 5449, BS 5546, BS 5440:1, BS 5440:2, BS 6798, BS 7593, BS 6891, IGE/UP/7 and IS 813 for IE.

All registered installers are required to notify building control when they have installed or exchanged a gas appliance in a residential dwelling, this can be done via Gas Safe, in GB. Gas Safe will then issue either a Building Compliance Certificate (for England and Wales) or a Declaration of Safety (Scotland, Northern Island, Isle of Man or appliances out of the scope of Building Regulations) to the homeowner, which will confirm that the work has been carried out by a competent Gas Safe Registered Installer.

Viessmann trained installers can register for free through www.viessmanninstallerportal.co.uk

Please note

Manufacturers instructions must not be taken in any way as overriding statutory obligations.

Boiler Position

The following limitations must be observed when siting the boiler:

- The boiler is not suitable for external installation. The position selected for the installation should be within the building, unless otherwise protected by a suitable enclosure and must allow adequate space for installation, servicing and operation of the appliance and for air circulation around it.
- The position must allow for a suitable flue system and terminal position. The boiler must be installed on a flat vertical wall capable of supporting the weight of the appliance and any ancillary equipment when full.
- If the boiler is to be fitted in a timber framed building it should be fitted in accordance with ige/up/7. If in doubt advice must be sought from the Institute of Gas Engineers.

Installation conditions for balanced flue operation (appliance type C)

The Vitodens can be installed as appliance type C13x, C33x, C53x or C63x to BS5440, for **balanced** flue operation **independent** of the size and ventilation of the installation room.

It may, for example, be installed in recreation rooms, in other living space, in ancillary rooms without ventilation, in cupboards (open at the top) and recesses without maintaining minimum clearances to combustible parts as well as in attic rooms (pitched attics and ancillary rooms) where the balanced flue pipe can be directly routed through the roof. Since the flue pipe connecting piece for balanced flue operation is surrounded by combustion air (coaxial pipe), no clearances towards combustible parts need to be maintained (for further details, see the technical guide "Flue gas systems for the Vitodens").

The installation location must be safe from the risk of frost.

Installation conditions for open flue operation (appliance type B)

(Type B23 and B33)

In rooms where **air contamination through halogenated hydrocarbons** can occur, such as hairdressing salons, printing shops, chemical cleaners, laboratories, etc., install the Vitodens only as balanced flue system.

Wall mounted boilers should not be installed in areas subject to very dusty conditions.

The installation location must be kept free from frost and must be adequately ventilated.

Provide a condensate drain (combined with blow-off pipe for the safety valve) in the installation room.

The maximum ambient temperature of the system should not exceed 35 °C.

Operation of the Vitodens in wet areas

The Vitodens is approved for installation in wet areas (e.g. bath or shower rooms) (protection IP X4 D, splash-proof). When installing the Vitodens in wet areas, observe the safety zones and minimum wall clearances according to IEE wiring regulation. The Vitodens may be installed **in safety zone 1**, if hosed water (e.g. through massage showers) is prevented.

Electrical safety zone

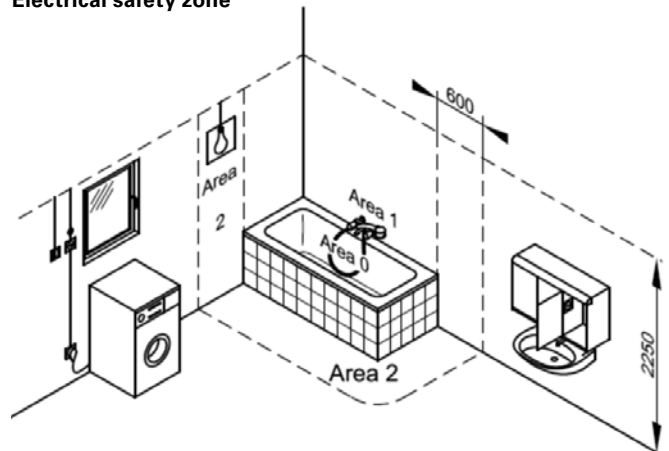

Minimum clearances

700 mm **to the front of the boiler** and/or unvented cylinder.
Minimum clearances to the LHS or RHS are not required.

Electrical connections

Recommended cables and leads

NYM-J 3 × 2.5 mm²

– mains power

2-core min. 0.75 mm²

– Vitotrol 100, Type UTDB
– Outdoor temperature sensor

NYM-O 3 × 1.5 mm²

– Vitotrol 100, Type RT
– Vitotrol 100, Typ UTA

Ensure the power supply complies with the requirements of your local power supply utility and current IEEE wiring regulations. The mains cable can be protected by a fuse with a maximum rating of 16 A.

It is recommended to install an AC/DC-sensitive RCD (RCD class B) for DC (fault) currents that can occur with energy-efficient equipment.

Make the power supply (230 V~, 50 Hz) via a permanent connection.

Connect the supply cables and accessories at the terminals inside the boiler.

Chemical anti-corrosion agents

Corrosion is generally avoided in correctly installed and operated sealed heating systems.

Chemical anti-corrosion agents should be avoided where possible. Some manufacturers of plastic pipes recommend the use of chemical additives. In such cases, only use anti-corrosion agents offered by the heating trade that have been approved for boilers with DHW heating via single-walled heat exchangers (plate heat exchanger or DHW un-vented cylinder).

Plastic pipe work for radiators

It is recommended to install a temperature limiter to restrict the maximum temperature of plastic pipes in heating circuits with radiators.

Attic or loft heating installation

The installation of a low water indicator specified as compulsory by BS EN 1282 is not required when installing the Vitodens in an attic or loft.

Underfloor heating system (UFH)

For heating systems with plastic pipes, we recommend the use of impermeable pipes to prevent the diffusion of oxygen through the pipe walls.

A temperature limiter is to be installed into the flow of the underfloor heating circuit to limit the maximum temperature.

Combined safety valve (heating circuit) and condensate drain

A safety valve in accordance with CE directive is integrated in the Vitodens (operating pressure 3 bar).

The condensate pipe is connected to the discharge pipe of the safety valve. The condensate hose supplied meets the temperature requirements that are part of the CE certification. Connecting the condensate pipe internally to the domestic waste water system, either directly or via a tundish or washing machine trap, is recommended.

Water quality/Frost protection

Unsuitable fill and top-up water increases the level of deposits and corrosion and may lead to boiler damage.

Regarding the quality and volume of heating water, incl. fill and top-up water, observe the Building Regulations Part L.

- Thoroughly flush the entire heating system prior to filling it with water.
- Only use fill water of potable quality.
- Soften fill water with a hardness above 3.0 mol/m³ (300ppm), e.g. with the small softening system for heating water
- An antifreeze additive suitable for heating systems can be mixed with the fill water. The antifreeze manufacturer must verify its suitability, otherwise damage to gaskets and diaphragms may occur, as well as noise during heating operation. Viessmann accepts no liability for damage or consequential damage as a result.

Expansion vessel

An 8 litre expansion vessel is integrated as standard in the Vitodens boiler, which is suitable for sealed heating systems with a maximum water content of up to 100 litres:

- Pre-charge pressure 0,75 bar
- Content 8 litres
- Content CH water volume Vitodens
 - 19 kW 2.8 litres
 - 26 kW 2.8 litres
 - 35 kW 3.4 litres

The size of the expansion vessel is subject to the heating system specification and should be checked in each case. If the integrated expansion vessel is not sufficient for the system then a second expansion vessel has to be used.

Viessmann Limited
Hortonwood 30, Telford
Shropshire, TF1 7YP
Tel: 01952 675000
Fax: 01952 675040
www.viessmann.co.uk

Your trade partner: