

# 5.1

## Views of Three-Dimensional Objects

### Focus on...

After this lesson, you will be able to...

- ❑ draw and label top, front, and side views of 3-D objects
- ❑ build 3-D objects when given top, front, and side views



### Materials

- 20 unit blocks
- masking tape
- isometric dot paper

### Literacy Link

To describe a three-dimensional (3-D) object, count its *faces*, *edges*, and *vertices*.

Face: flat or curved surface

Edge: line segment where two faces meet

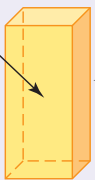

Vertex: point where three or more edges meet

Sable and Josh are trying to build exactly the same three-dimensional (3-D) object. They each have the same number of blocks, but they cannot see each other's object.

Using a common vocabulary can help Sable and Josh build the same object.

### Explore the Math

#### How can you describe and build three-dimensional objects?

1. Work with a partner. Create a 3-D object using ten unit blocks. Make sure your partner cannot see your object.
2. Describe your completed object to your partner, and have your partner try to build the same object. What key words did you use that were helpful?
3. Decide which faces will be the front and top of your object. Then determine which faces are the bottom, left side, right side, and back. You may wish to label the faces with tape. Then, describe your object to your partner again. Was it easier to describe this time?

4. Using isometric dot paper, draw what your object looks like.

### Reflect on Your Findings

5. a) Do you need to know all the views to construct an object? If not, which ones would you use and why?
- b) Explain why you might need to have only one side view, if the top and front views are also given.
- c) Are any other views unnecessary? Are they needed to construct the same object?

Using isometric dot paper makes it easier to draw 3-D shapes. Follow the steps to draw a rectangular solid.

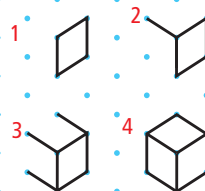

Each view shows two dimensions. When combined, these views create a 3-D diagram.

### Example 1: Draw and Label Top, Front, and Side Views

Using blank paper, draw the top, front, and side views of these items. Label each view.

a) Tissue box



b) Compact disk case



### Solution

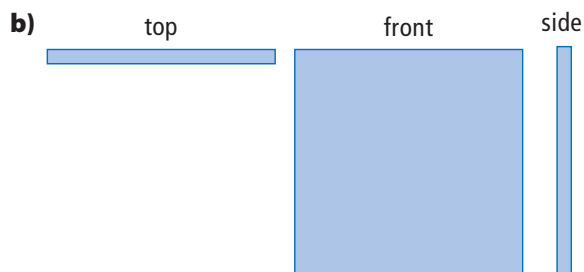
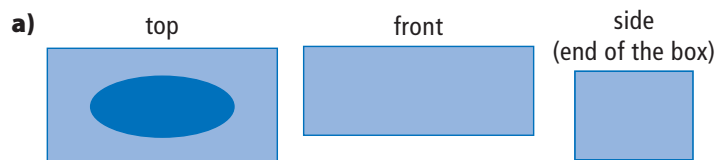

## Show You Know

Using blank paper, draw the top, front, and side views of this object.

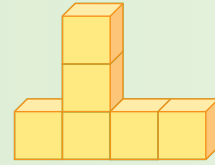

### Did You Know?

Architects use top views to draw blueprints for buildings.

## Example 2: Sketch a Three-Dimensional Object When Given Views

These views were drawn for an object made of ten blocks. Sketch what the object looks like.

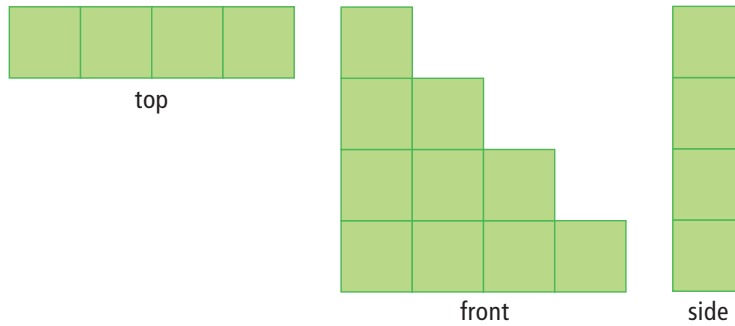

### Solution

Use isometric dot paper to sketch the object.

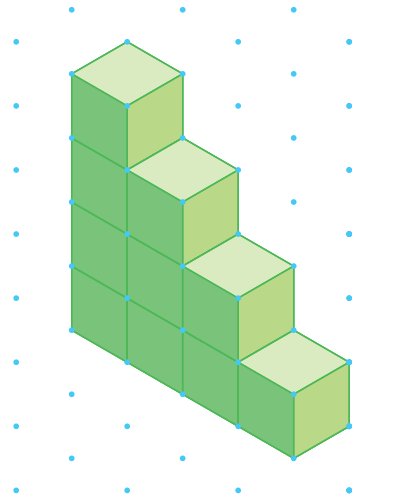

## Show You Know

An object is created using eight blocks. It has the following top, front, and side views. Sketch what the object looks like on isometric dot paper.

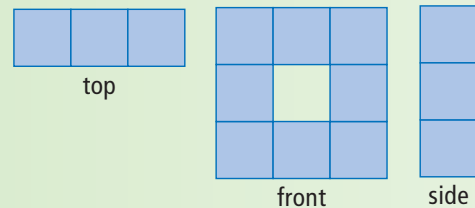

### Example 3: Predict and Draw the Top, Front, and Side Views After a Rotation

The diagrams show the top, front, and side views of the computer tower.

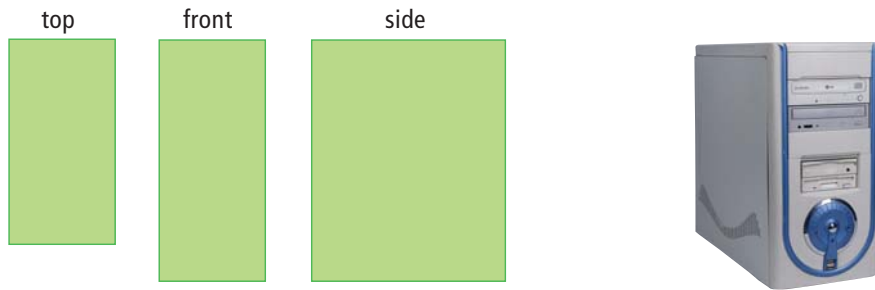

You want to rotate the computer tower  $90^\circ$  clockwise on its base to fit into your new desk. Predict which view you believe will become the front view after the rotation. Then, draw the top, front, and side views after rotating the tower.

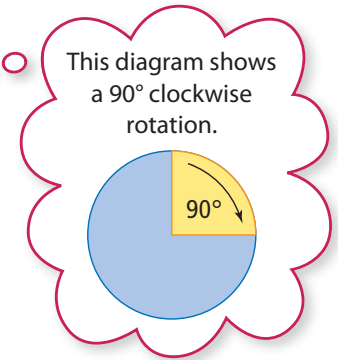

#### Solution

The original side view will become the new front view after the rotation.

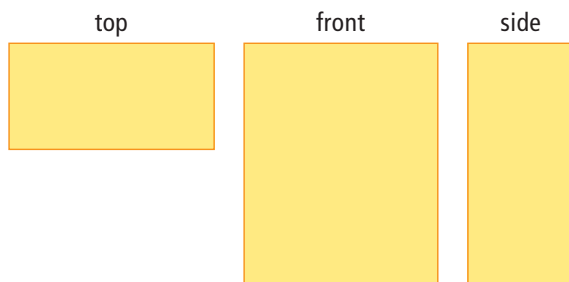

**Tech Link**

You can use a Draw program to create 3-D objects.

#### Show You Know

Stand your *MathLinks 8* student resource on your desk. Predict what the top, front, and side views will look like if you rotate it  $90^\circ$  clockwise about its spine. Then, draw the top, front, and side views after rotating the book.

## Key Ideas

- A minimum of three views are needed to describe a 3-D object.
- Using the top, front, and side views, you can build or draw a 3-D object.

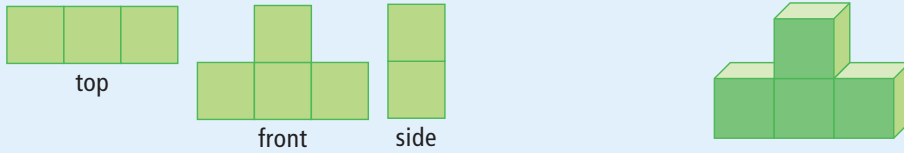

## Communicate the Ideas

1. Raina insists that you need to tell her all six views so she can draw your object. Is she correct? Explain why or why not.
2. Are these views correct? Justify your answer.

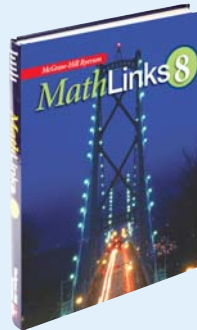
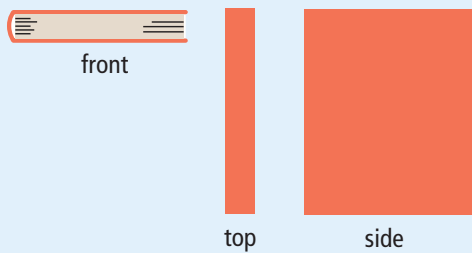

## Check Your Understanding

### Practise

For help with #3 and #4, refer to Example 1 on pages 165–166.

3. Sketch and label the top, front, and side views.

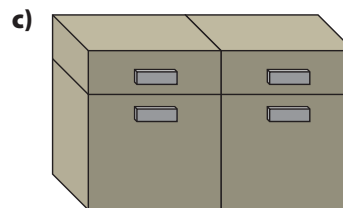
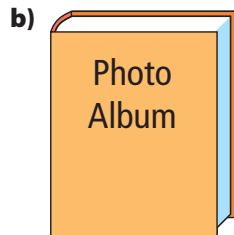
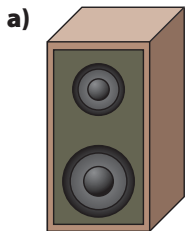

4. Choose the correct top, front, and side view for this object and label each one.

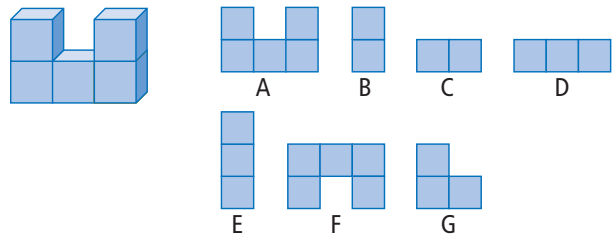

For help with #5, refer to Example 2 on page 166.

5. Draw each 3-D object using the views below.

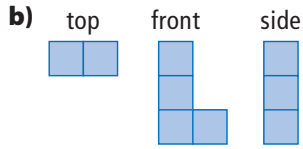
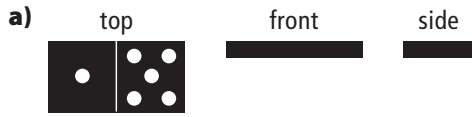

For help with #6 and #7, refer to Example 3 on page 167.

6. A television set has the following views.

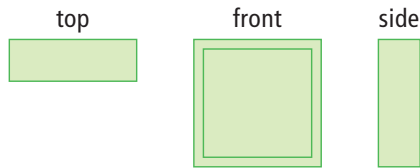

If you turn the television  $90^\circ$  counterclockwise, how would the three views change? Sketch and label each new view.

7. Choose which object has a front view like this after a rotation of  $90^\circ$  clockwise onto its side.

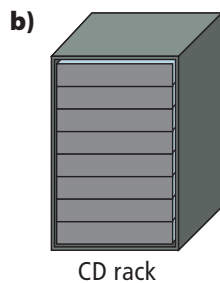
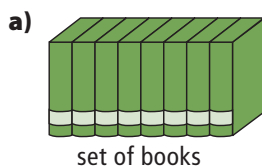

## Apply

8. Choose two 3-D objects from your classroom. Sketch the top, front, and side views for each one.
9. Sketch the front, top, and right side views for these solids.

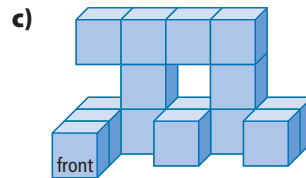
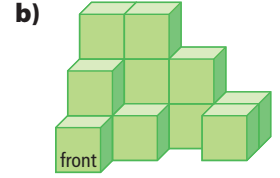
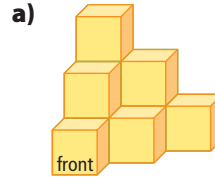

## Extend

10. Describe two objects that meet this requirement: When you rotate an object  $90^\circ$ , the top, front, and side views are the same as the top, front, and side views of the object before it was rotated.
11. An injured bumblebee sits at a vertex of a cube with edge length 1 m. The bee moves along the edges of the cube and comes back to the original vertex without visiting any other vertex twice.
- Draw diagrams to show the bumblebee's trip around the cube.
  - What is the length, in metres, of the longest trip?

## MATH LINK

Choose one of the essential buildings that you discussed for your new community on page 163. Draw and label a front, side, and top view.

# 5.2

## Nets of Three-Dimensional Objects

### Focus on...

After this lesson, you will be able to...

- determine the correct nets for 3-D objects
- build 3-D objects from nets
- draw nets for 3-D objects

### rectangular prism

- a prism whose bases are congruent rectangles



### Materials

- grid paper
- scissors
- clear tape
- rectangular prisms (blocks of wood, cardboard boxes, unit blocks)

### net

- a two-dimensional shape that, when folded, encloses a 3-D object

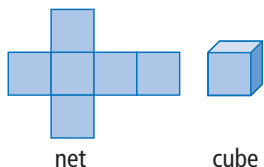

Shipping containers help distribute materials all over the world. Items can be shipped by boat, train, or transport truck to any destination using these containers. Shipping containers are right **rectangular prisms**. Why do you think this shape is used?

### Explore the Math

#### How do you know if a net can build a right rectangular prism?

Here are a variety of possible **nets** for a right rectangular prism.



rectangular prism

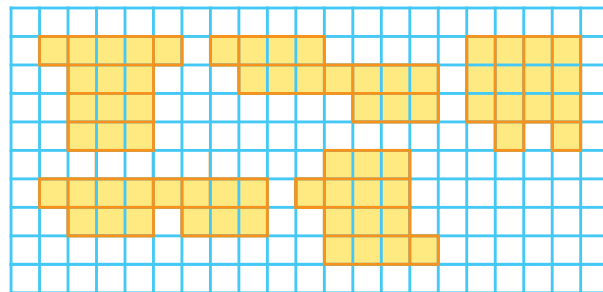

1. Draw each net on grid paper.

### Literacy Link

A *right prism* has sides that are perpendicular to the bases of the prism.

2. Predict which nets will form a right rectangular prism.
3. Cut each net out along the outside edges and fold along the inside edges, taping the cut edges to try to form a right rectangular prism.
4. Do all the nets create right rectangular prisms?
5. Place a right rectangular prism (such as a small cardboard box) on a piece of blank paper. “Roll” the prism onto its faces, trace each face, and try to draw another correct net. Your net should be different from the examples you have already made.

### Reflect on Your Findings

6. a) Compare the net you drew with those of three of your classmates. What is the same and different about your nets?
- b) Is there more than one way to draw a net for a 3-D object? Explain your answer.

### Example 1: Draw a Net for a Three-Dimensional Object

A company asks you to create an umbrella stand for large beach umbrellas. Draw the net for the umbrella stand.



#### Solution

Visualize what the umbrella stand would look like if you could cut it open and flatten it. The net has one circle and a rectangle. When the rectangle is curved around the circle, the net will form a cylinder with an open top. The width of the rectangle is equal to the circumference of the circle.

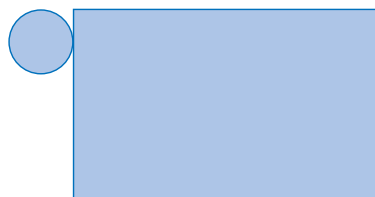

#### Show You Know

Draw a net for an unopened soup can.



## Example 2: Build a Three-Dimensional Object From a Given Net

Before going to leadership camp, your group needs to put a tent together. Can this net be folded to form the shape of a tent?

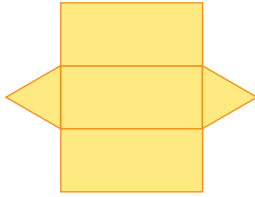

### Strategies

#### Model It

#### triangular prism

- a prism with two triangular bases each the same size and shape

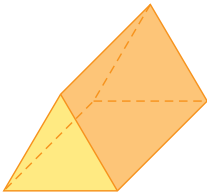

### Solution

Trace the net onto paper. Cut along the outside edges and fold along the inside edges. Tape the cut edges together to try to build a right **triangular prism**.

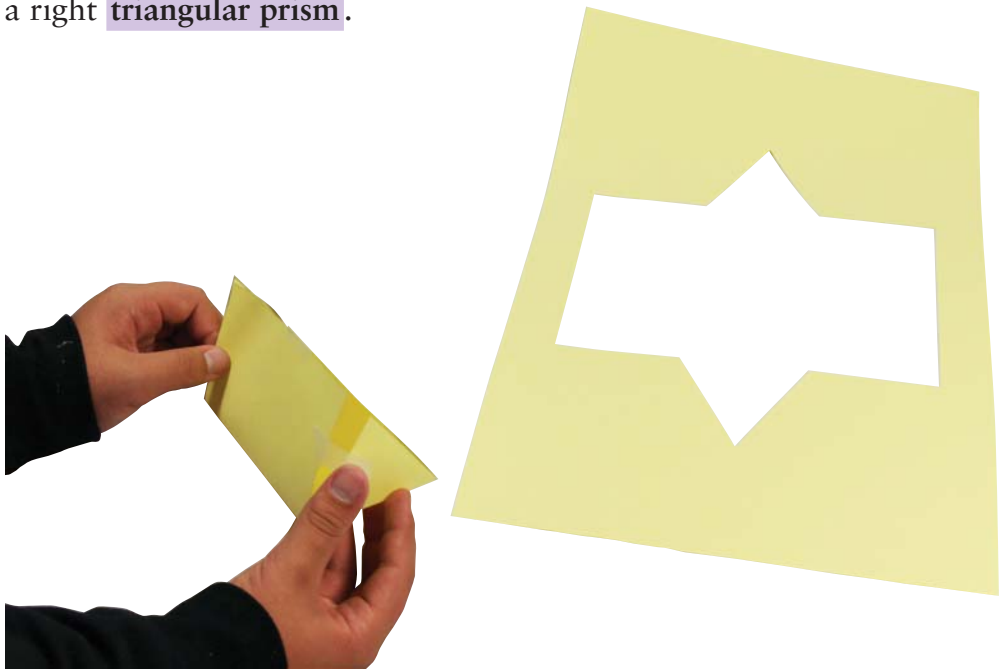

The net can be folded to form the shape of a tent.

### Show You Know

Build a 3-D object using this net. What object does it make?

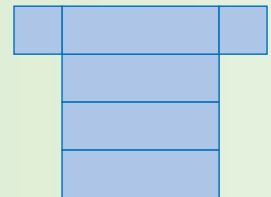

## Key Ideas

- A net is a two-dimensional shape that, when folded, encloses a three-dimensional object.
- The same 3-D object can be created by folding different nets.
- You can draw a net for an object by visualizing what it would look like if you cut along the edges and flattened it out.

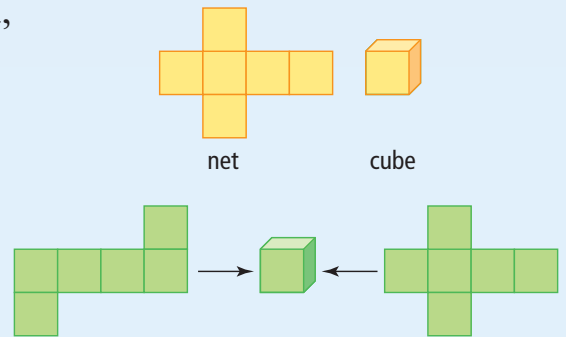

## Communicate the Ideas

1. Both of these nets have six faces, like a cube. Will both nets form a cube? Justify your answer.

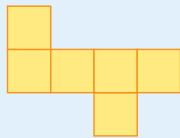

Net A

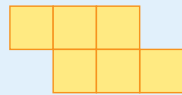

Net B

2. Patricia is playing the lead role in the school musical this year. She missed Math class while she was performing. She cannot figure out if a net will build the correct 3-D object, and asks you for help after school. Show how you would help her figure out this problem.

## Check Your Understanding

### Practise

For help with #3 to #5, refer to Example 1 on page 171.

3. Sketch a net for each object.

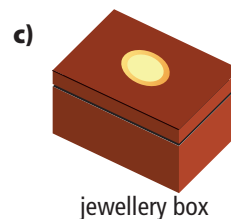

4. Draw the net for each object. Label the measurements on the net.

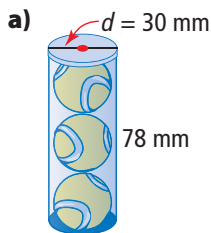

**Did You Know?**  
A ream describes a quantity of approximately 500 sheets of paper.

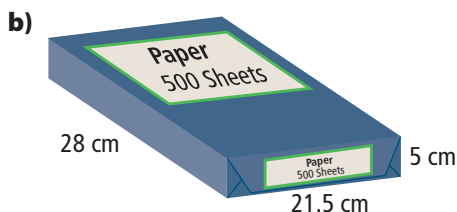

5. Draw a net on grid paper for a rectangular prism with the following measurements: length is six units, width is four units, and height is two units.

For help with #6 and #7, refer to Example 2 on page 172.

6. a) Draw the net on grid paper, as shown. Cut along the outside edges of the net and fold to form a 3-D object.

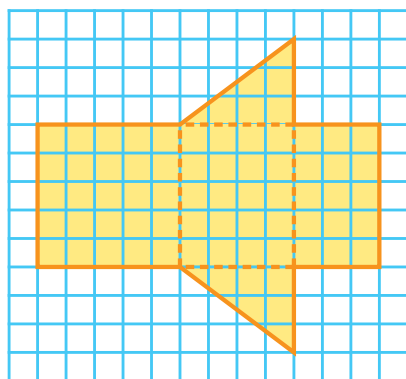

b) What is this object called?

7. Match each solid with its net. Copy the nets, then try to create the 3-D objects.

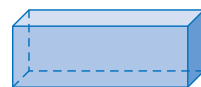

rectangular prism

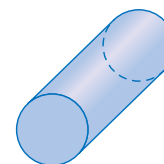

cylinder

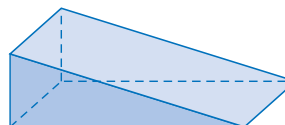

triangular prism

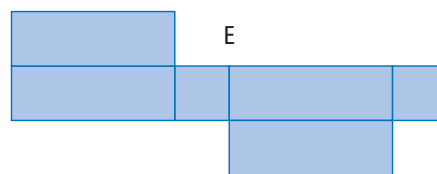
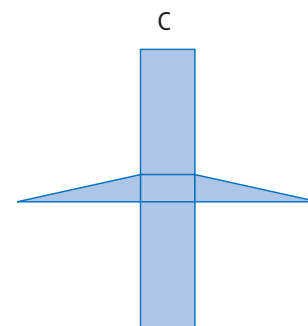
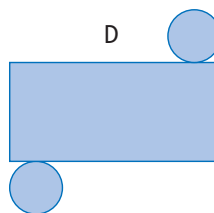
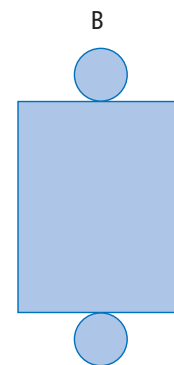
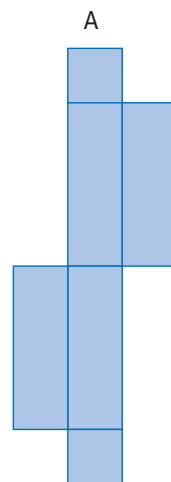

**Apply**

- A box of pens measures 15.5 cm by 7 cm by 2.5 cm. Draw a net for the box on a piece of centimetre grid paper. Then, cut it out and fold it to form the box.
- You are designing a new mailbox. Draw a net of your creation. Include all measurements.

10. Simon designed two nets.

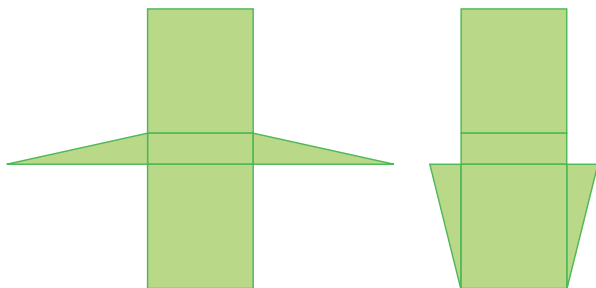

- Enlarge both nets on grid paper, and build the 3-D objects they form.
- What object does each net form?

12. The six sides of a cube are each a different colour. Four of the views are shown below.

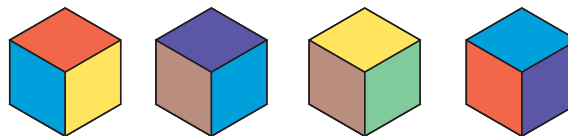

What colour is on the opposite side of each of these faces?

- purple
- blue
- red

### Extend

11. Hannah and Dakota design a spelling board game. They use letter tiles to create words. Tiles may be stacked (limit of four) on top of letters already used for a word on the board to form a new word.

- Draw a 3-D picture of what these stacked tiles might look like.
- Draw a top view that illustrates the stacked tiles for people reading the instructions.

13. How many possible nets can create a cube? Sketch all of them. The first one is done for you.

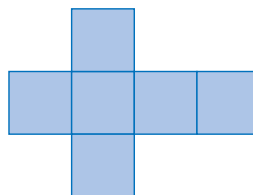

## MATH LINK

When buildings are designed, it is important to consider engineering principles, maximum and minimum height requirements, and budget.

- Create a 3-D sketch of two buildings for your miniature community, one that is a prism and one that is a cylinder.
- Draw a net of each building, including all possible measurements needed to build your miniature.



# 5.3

## Surface Area of a Prism

### Focus on...

After this lesson, you will be able to...

- link area to surface area
- find the surface area of a right prism



Most products come in some sort of packaging. You can help conserve energy and natural resources by purchasing products that

- are made using recycled material
- use recycled material for packaging
- do not use any packaging

What other ways could you reduce packaging?

### Explore the Math

#### Materials

- empty cardboard box (cereal box, granola box, snack box, etc.)
- scissors
- ruler
- scrap paper

#### How can you determine the surface area of a package?

1. Choose an empty cardboard box. Cut along edges of the box so it unfolds to form a net.



Do you need to include the material used in the overlapping flaps? Why or why not?

2. Suppose you want to design an advertisement to place on the outside of your box. How can you determine the surface area you have to work with?

#### Reflect on Your Findings

3. a) Share your method with several of your classmates. Discuss any similarities or differences between the methods.
- b) Which method do you prefer to use? Justify your response.

## Example 1: Calculate the Surface Area of a Right Rectangular Prism

a) Draw the net of this right rectangular prism.

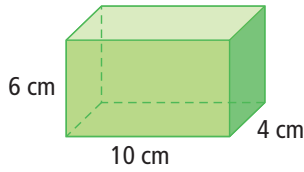

b) What is the **surface area** of the prism?

### Solution

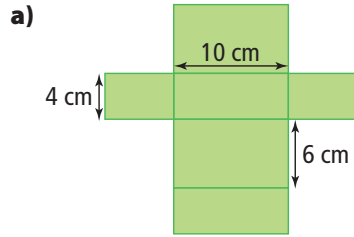

b) The right rectangular prism has faces that are three different sizes.

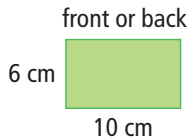

$$A = l \times w$$

$$A = 10 \times 6$$

$$A = 60$$

The area of the front or back is  $60 \text{ cm}^2$ .

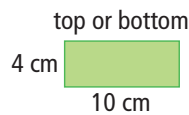

$$A = l \times w$$

$$A = 10 \times 4$$

$$A = 40$$

The area of the top or bottom is  $40 \text{ cm}^2$ .

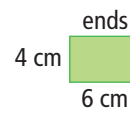

$$A = l \times w$$

$$A = 6 \times 4$$

$$A = 24$$

The area of each end is  $24 \text{ cm}^2$ .

### surface area

- the number of square units needed to cover a 3-D object
- the sum of the areas of all the faces of an object

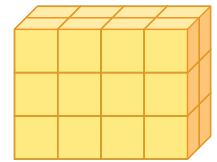

Area is measured in square units. For example, square centimetres, square metres, etc.

The surface area is the sum of the areas of all the faces.

The front and back have the same area:

$$A = 60 \times 2$$

$$A = 120$$

The top and bottom have the same area:

$$A = 40 \times 2$$

$$A = 80$$

The two ends have the same area:

$$A = 24 \times 2$$

$$A = 48$$

$$\begin{aligned} \text{Surface area} &= (\text{area of front and back}) + (\text{area of top and bottom}) \\ &\quad + (\text{area of ends}) \\ &= 120 + 80 + 48 \\ &= 248 \end{aligned}$$

The surface area of the right rectangular prism is  $248 \text{ cm}^2$ .

### Strategies

How else could you calculate the surface area?

You could add the areas you calculated first.  $60 + 40 + 24 = 124$

Each area is the same as the area of one other face, so you could then multiply the total by two.  $124 \times 2 = 248$



## Show You Know

What is the surface area of this right rectangular prism?

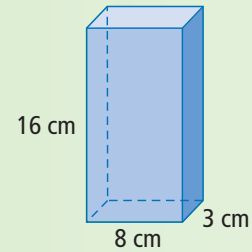

## Example 2: Calculate the Surface Area of a Right Triangular Prism

- Draw the net of this right triangular prism.
- What is the surface area?

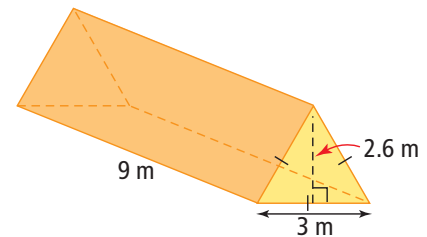

### Solution

a)

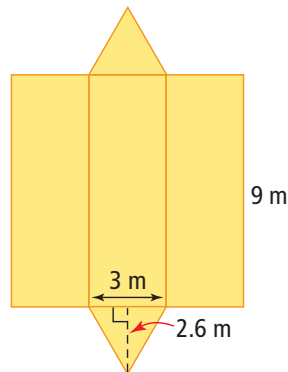

#### Strategies

Draw a Diagram

#### Strategies

What other strategies could you use?

- The bases of the prism are equilateral triangles. The sides of the prism are rectangles.

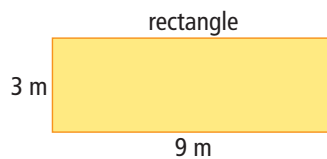

$$A = l \times w$$

$$A = 9 \times 3$$

$$A = 27$$

The area of one rectangle is  $27 \text{ m}^2$ .

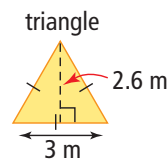

$$A = (b \times h) \div 2$$

$$A = (3 \times 2.6) \div 2$$

$$A = 7.8 \div 2$$

$$A = 3.9$$

The area of one triangle is  $3.9 \text{ m}^2$ .

#### Literacy Link

An equilateral triangle has three equal sides and three equal angles. Equal sides are shown on diagrams by placing tick marks on them.

This right triangular prism has five faces.

There are three rectangles of the same size and two triangles of the same size.

$$\begin{aligned}\text{Surface area} &= (3 \times \text{area of rectangle}) + (2 \times \text{area of triangle}) \\ &= (3 \times 27) + (2 \times 3.9) \\ &= 81 + 7.8 \\ &= 88.8\end{aligned}$$

The surface area of the right triangular prism is  $88.8 \text{ m}^2$ .

### Show You Know

Find the surface area of this triangular prism.

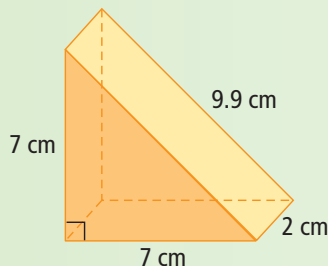

### Key Ideas

- Surface area is the sum of the areas of all the faces of a 3-D object.

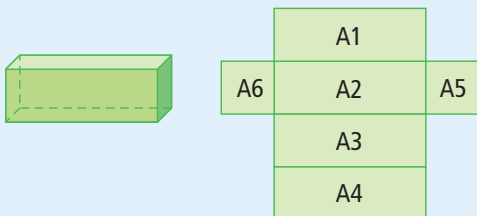

Surface Area =  $A1 + A2 + A3 + A4 + A5 + A6$ ,  
where  $A1$  represents the area of rectangle 1,  $A2$   
represents the area of rectangle 2, etc.

### Communicate the Ideas

1. Write a set of guidelines that you could use to find the surface area of a prism. Share your guidelines with a classmate.
2. A right rectangular prism has six faces. Why might you have to find the area of only three of the faces to be able to find the surface area? Use pictures and words to explain your thinking.



# Check Your Understanding

## Practise

For help with #3 and #4, refer to Example 1 on page 177.

3. Find the surface area of this right rectangular prism to the nearest tenth of a square centimetre.

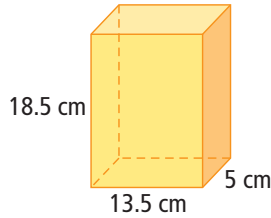

4. Find the surface area of this CD case.

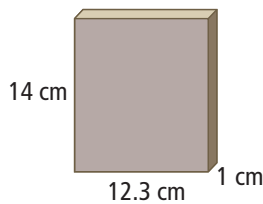

For help with #5 to #7, refer to Example 2 on pages 178–179.

5. Calculate the surface area of this ramp in the shape of a right triangular prism. Give your answer to the nearest tenth of a square metre.

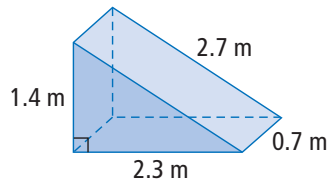

7. Given the area of each face of a right rectangular prism, what is the surface area?

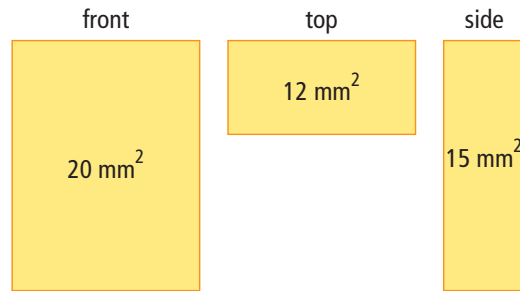

8. Paco builds a glass greenhouse.

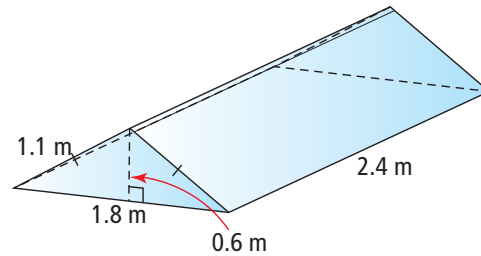

- How many glass faces does the greenhouse have?
  - How much glass does Paco need to buy?
9. What is the minimum amount of material needed to make the cover of this textbook if there is no overlap? Give your answer to the nearest square millimetre.

## Apply

6. Cheese is sometimes packaged in a triangular box. How much cardboard would you need to cover this piece of cheese if you do not include overlapping? Calculate your answer to the nearest tenth of a square centimetre.

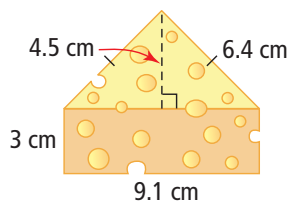

The tick marks on the two sides of the triangle indicate that these sides are equal.

10. Jay wants to make a bike ramp. He draws the following sketch. What is the surface area of the ramp?

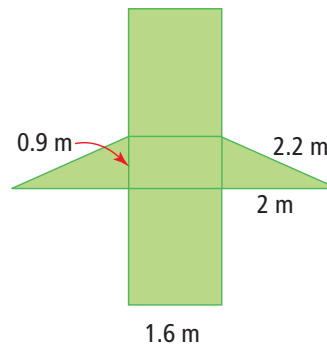

11. Dallas wants to paint three cubes. The cubes measure  $1\text{ m} \times 1\text{ m} \times 1\text{ m}$ ,  $2\text{ m} \times 2\text{ m} \times 2\text{ m}$ , and  $3\text{ m} \times 3\text{ m} \times 3\text{ m}$ , respectively. What total surface area will Dallas paint if he decides not to paint the bottoms of the three cubes?

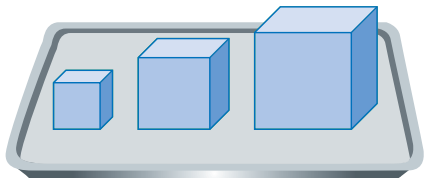

12. Tadika has a gift to wrap. Both of these containers will hold her gift. Which container would allow her to use the least amount of wrapping paper? Explain your choice.

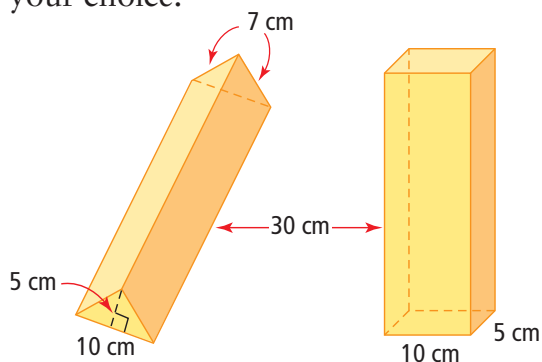

### Extend

13. A square cake pan measures 30 cm on each side and is 5 cm deep. Cody wants to coat the inside of the pan with non-stick oil. If a single can of non-stick oil covers an area of  $400\,000\text{ cm}^2$ , how many pans can be coated with a single can?

14. Ethan is hosting games night this weekend. He bought ten packages of playing cards. Each package measures  $9\text{ cm} \times 6.5\text{ cm} \times 1.7\text{ cm}$ . He wants to build a container to hold all ten packages of cards.

- a) What are the minimum inside dimensions of the container?  
b) Is there more than one kind of container that would work? Draw diagrams to help explain your answer.

15. a) If the edge length of a cube is doubled, find the ratio of the old surface area to the new surface area.  
b) What happens if the edge length of a cube is tripled? Is there a pattern?

16. Shelby wants to paint the walls and ceiling of a rectangular room.

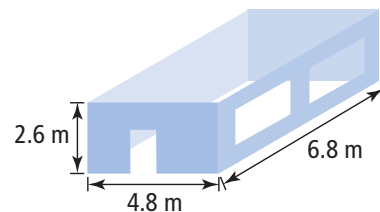

Type of Paint	Size of Paint Can	Cost
Wall paint	4 L	\$24.95
	1 L	\$7.99
Ceiling paint	4 L	\$32.95

One litre of paint covers  $9.5\text{ m}^2$ .

- a) What is the least amount of paint Shelby can buy to paint the room (subtract  $5\text{ m}^2$  for the door and windows)?  
b) How much will the paint cost, including the amount of tax charged in your region?

## MATH LINK

For the prism-shaped building you created in the Math Link on page 175, how much material do you need to cover the exterior walls and the roof of the building?

# 5.4

## Surface Area of a Cylinder

### Focus on...

After this lesson, you will be able to...

- find the surface area of a cylinder



Glow sticks work because of a chemical reaction. There are two solutions in separate compartments inside the stick. Once you bend the stick, the two solutions mix. This mixture creates a new solution that gives off light. The colour of the glow stick depends on the dye in the mixture. How might you determine how much plastic would be needed to make a glow stick to fit around your wrist?

### Explore the Math

#### cylinder

- a three-dimensional object with two parallel and congruent circular bases

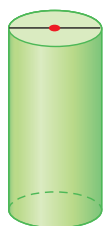

cylinder

#### How do you find the surface area of a right cylinder?

Work with a partner.

1. a) Draw the net of a glow stick. Use the actual dimensions from the diagram shown.  
b) Describe each face of your net.

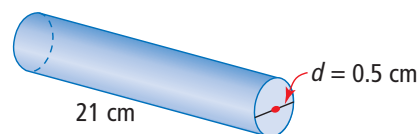

2. How can you use what you know about circles to help you find the surface area of the glow stick?

- What is the surface area of the glow stick, to the nearest hundredth of a square centimetre? Include the units in your final answer.
- Share your strategies with another group.

### Reflect on Your Findings

- Would your method work for any right cylinder? Explain your reasoning.

### Example 1: Determine the Surface Area of a Right Cylinder

- Estimate the surface area of the can.
- What is the surface area of the can? Express your answer to the nearest hundredth of a square centimetre?



#### Solution

The surface area of the can is found by adding the areas of the two circular bases and the rectangular side that surrounds them.

The width,  $w$ , of the rectangle is the height of the can.

The length,  $l$ , of the rectangle is equal to the circumference of the circle.

- To estimate, use approximate values:

$$d \approx 8 \text{ cm}, w \approx 10 \text{ cm}, \pi \approx 3.$$

$$\begin{aligned} \text{Area of circle} &= \pi \times r^2 \\ &\approx 3 \times 4 \times 4 \\ &\approx 48 \end{aligned}$$

$r^2$  means  
 $r \times r$

How is the radius related to the diameter?

There are two circles:

$$2 \times 48 = 96$$

The area of the two circles is approximately  $96 \text{ cm}^2$ .

$$\begin{aligned} \text{Area of rectangle} &= l \times w \\ &= (\pi \times d) \times w \\ &\approx 3 \times 8 \times 10 \\ &\approx 240 \end{aligned}$$

What formulas could you use to find the circumference of a circle?

The area of the rectangle is approximately  $240 \text{ cm}^2$ .

$$\begin{aligned} \text{Estimated surface area} &= \text{area of two circles} + \text{area of rectangle} \\ &\approx 96 + 240 \\ &\approx 340 \end{aligned}$$

The estimated surface area is  $340 \text{ cm}^2$ .

### Did You Know?

Pop cans are cylinders. The world's largest Coke™ can is located in Portage la Prairie, Manitoba.



### Literacy Link

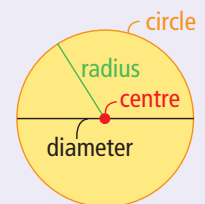

**Strategies****Draw a Diagram****b) Method 1: Use a Net**

Draw the net and label the measurements.

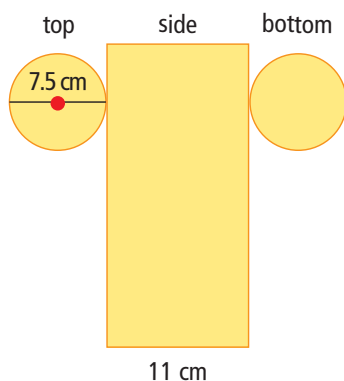

The diameter of the circle is 7.5 cm.

Determine the radius.

$$7.5 \div 2 = 3.75$$

The radius of the circle is 3.75 cm.

Find the area of one circle.

$$A = \pi \times r^2$$

$$A \approx 3.14 \times 3.75^2$$

$$A \approx 44.15625$$

Use 3.14 as an approximate value for  $\pi$ .

The area of one circle is approximately 44.15625 cm<sup>2</sup>.

Find the area of two circles.

$$2 \times 44.15625 = 88.3125$$

The area of both circles is approximately 88.3125 cm<sup>2</sup>.

Find the area of the rectangle using the circumference of the circle.

$$A = l \times w$$

$$A = (\pi \times d) \times w$$

$$A \approx 3.14 \times 7.5 \times 11$$

$$A \approx 259.05$$

The area of the rectangle is approximately 259.05 cm<sup>2</sup>.

Calculate the total surface area.

$$\text{Surface area} = 88.3125 + 259.05$$

$$= 347.3625$$

The total surface area is approximately 347.36 cm<sup>2</sup>.

Round your answer at the end of the calculation.

### Method 2: Use a Formula.

Use this formula to find the total surface area of any cylinder.

$$S.A. = 2 \times (\pi \times r^2) + (\pi \times d \times h)$$

$$S.A. \approx 2 \times (3.14 \times 3.752) + (3.14 \times 7.5 \times 11)$$

$$S.A. \approx 88.3125 + 259.05$$

$$S.A. \approx 347.3625$$

The total surface area is 347.36 cm<sup>2</sup>, to the nearest hundredth.

This formula incorporates each shape and its area formula to find the surface area.

$$2 \times (\pi \times r^2) + (\pi \times d) \times h$$

two circles      circle area formula      +      rectangle area formula (length is the circumference of a circle; width is the height of the cylinder)

### Show You Know

Calculate the surface area of this cylinder to the nearest tenth of a square centimetre.

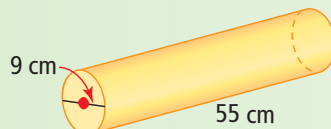

### Literacy Link

The abbreviation S.A. is often used as a short form for surface area.

### Example 2: Use the Surface Area of a Cylinder

Calculate the surface area of this totem pole, including the two circular bases. The pole stands 2.4 m tall and has a diameter of 0.75 m. Give your answer to the nearest hundredth of a square metre.

#### Solution

The cylinder has two circular bases.

The area of one circle is:

$$A = \pi \times r^2$$
$$A \approx 3.14 \times 0.375^2$$

$$r = d \div 2$$

$$A \approx 0.4415625$$

The area of the circle is approximately 0.4415625 m<sup>2</sup>.

There are two circles, so the area of both circles is approximately 0.883125 m<sup>2</sup>.

Calculate the total surface area.

$$S.A. \approx 0.883125 + 5.652$$

$$S.A. \approx 6.535125$$

The total surface area is approximately 6.54 m<sup>2</sup>.

The side of the cylinder is a rectangle.

The area of the rectangle is:

$$A = (\pi \times d) \times h$$

$$A \approx 3.14 \times 0.75 \times 2.4$$

$$A \approx 5.652$$

The area of the rectangle is approximately 5.652 m<sup>2</sup>.

Replace one dimension with the formula for the circumference of a circle.



This metal totem pole was created by Todd Baker, Squamish Nation. It represents the Birth of the Bear Clan, with the princess of the clan on the top half and the bear on the bottom half.

### Show You Know

Calculate the surface area of a cylindrical waste bucket without a lid that measures 28 cm high and 18 cm in diameter. Give your answer to the nearest square centimetre.

## Key Ideas

- The surface area of a cylinder is the sum of the areas of its faces.
- A net of a cylinder is made up of one rectangle and two circles.
- To find one of the dimensions of the rectangle, calculate the circumference of the circle.

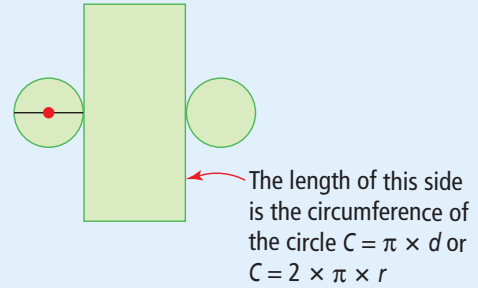

## Communicate the Ideas

1. What are the similarities and differences between finding the surface area of a prism and finding the surface area of a cylinder?
2. Explain why you need to find the circumference of a circle to find the surface area of a cylinder.

## Check Your Understanding

### Practise

For help with #3 to #7, refer to Examples 1 and 2 on pages 183–185.

3. a) Draw a net for this cylinder.  
b) Sketch a different net for this cylinder.

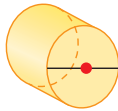

4. Estimate the surface area of each cylinder. Then, calculate each surface area to the nearest tenth of a square centimetre.

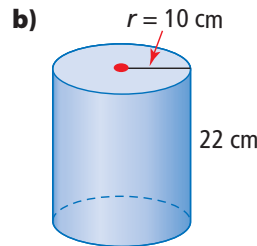
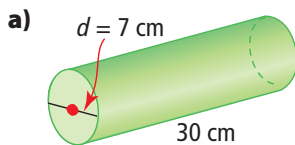

5. Find the surface area of each object to the nearest tenth of a square unit.

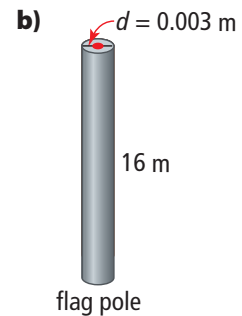
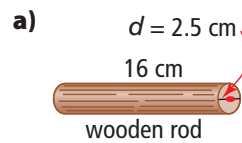

6. Use the formula  $S.A. = 2 \times (\pi \times r^2) + (\pi \times d \times h)$  to calculate the surface area of each object. Give each answer to the nearest hundredth of a square unit.

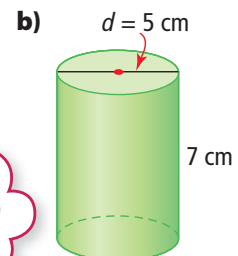
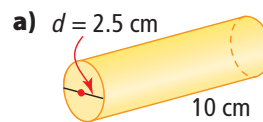

You can simplify the formula:  

$$S.A. = 2 \times (\pi \times r^2) + (\pi \times d \times h)$$

$$= 2\pi r^2 + \pi dh$$

7. Do you prefer to find the surface area of a cylinder by using the sum of the area of each face or by using a formula? Give at least two reasons for your choice.

### Apply

8. Anu wants to re-cover the cylindrical stool in his bedroom. How much material does he need if there is no overlap and he does not cover the bottom of the stool?

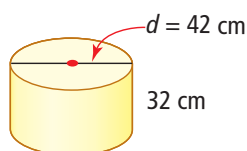

9. Kaitlyn and Hakim each bought a tube of candy. Both containers cost the same amount. Which container required more plastic to make?

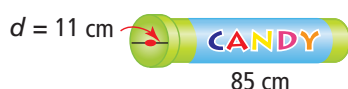

10. Paper towel is rolled around a cardboard tube. Calculate the outside surface area of the tube.

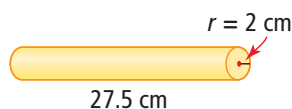

### Did You Know?

Each person produces about 1.59 kg of trash each day. Most of this is paper products.

### Extend

11. If each tennis ball has a diameter of 7 cm, calculate the amount of material needed to make a can that holds three tennis balls.

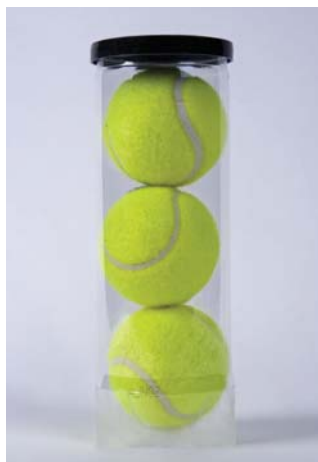

12. Coins can be stored in a plastic wrapper similar to a cylinder. A roll of dimes contains 50 coins. Each dime has a diameter of 17.5 mm and a thickness of 1 mm. Calculate the minimum surface area of the plastic wrapper.
13. A paint roller in the shape of a cylinder with a radius of 4 cm and a length of 21 cm is rolled vertically on a wall.
- What is the length and width of the wet path after ten complete rolls?
  - What area does the paint cover?

## MATH LINK

For the cylindrical building you created in the Math Link on page 175, how much material do you need to cover the exterior walls and the roof of the building?

### Did You Know?

Douglas J. Cardinal, one of the world's most acclaimed architects, uses his European, Blackfoot, and Ojibwa roots when designing buildings. He is known for his design of The Canadian Museum of Civilization in Gatineau, Québec, as well as a number of buildings in Western Canada, such as Telus World of Science in Edmonton and First Nations University of Canada in Regina.