



**Victorian Certificate of Education  
2009**

SUPERVISOR TO ATTACH PROCESSING LABEL HERE

**STUDENT NUMBER**

Figures	<input type="text"/>	<input type="text"/>	<input type="text"/>	<input type="text"/>	<input type="text"/>	<input type="text"/>	<input type="text"/>	<input type="text"/>	Letter
Words	<input type="text"/>	<input type="text"/>	<input type="text"/>	<input type="text"/>	<input type="text"/>	<input type="text"/>	<input type="text"/>	<input type="text"/>	<input type="text"/>

**VISUAL COMMUNICATION AND DESIGN**

**Written examination**

**Tuesday 10 November 2009**

**Reading time: 11.45 am to 12.00 noon (15 minutes)**

**Writing time: 12.00 noon to 1.30 pm (1 hour 30 minutes)**

**QUESTION AND ANSWER BOOK**

**Structure of book**

<i>Number of questions</i>	<i>Number of questions to be answered</i>	<i>Number of marks</i>
8	8	88

- Students are permitted to bring into the examination room: pens, lead and coloured pencils, water-based pens and markers, highlighters, erasers, sharpeners, rulers, set squares, protractors and compasses.
- Students are NOT permitted to bring into the examination room: tee-squares and boards, compressed gas sprays, equipment requiring a power source, blank sheets of paper and/or white out liquid/tape.
- No calculator is allowed in this examination.

**Materials supplied**

- Question and answer book of 15 pages.
- Resource book of 10 pages.

**Instructions**

- Write your **student number** in the space provided above on this page.
- All written responses must be in English.

**At the end of the examination**

- You may keep the resource book.

**Students are NOT permitted to bring mobile phones and/or any other unauthorised electronic devices into the examination room.**

**Instructions**

Answer **all** questions in the spaces provided.

**Question 1**

Below are examples of six drawing systems used to produce visual communications. Number the boxes to match each drawing system with the correct example shown.

1.

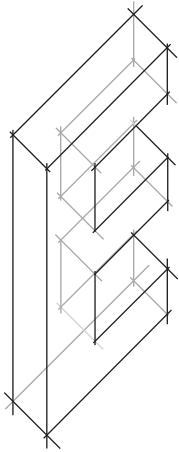

2.

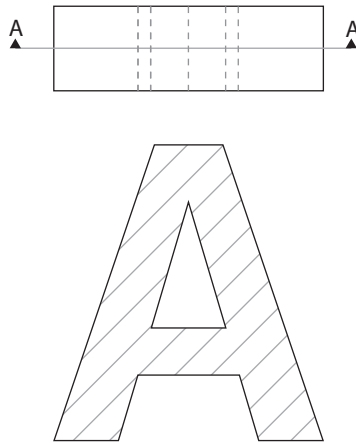

3.

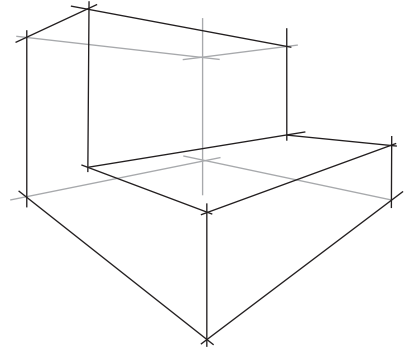

4.

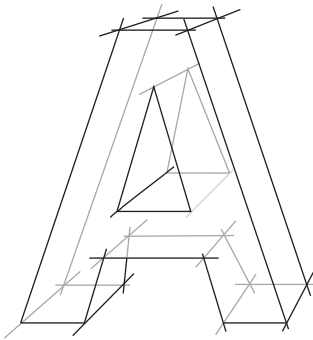

5.

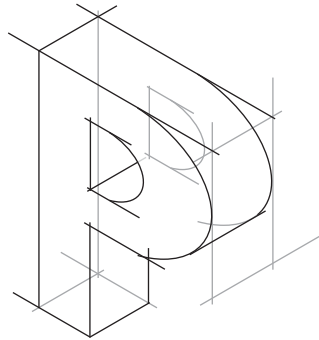

6.

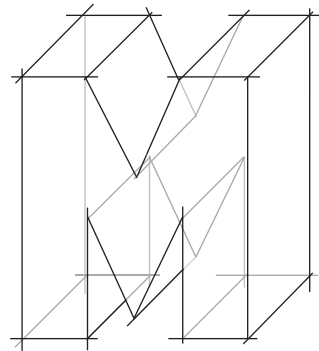

- a two-point perspective drawing
- a planometric drawing
- an isometric drawing

- a sectional drawing
- an oblique drawing
- a one-point perspective drawing

6 marks

**Question 2**

Below are four tonal renderings of objects. Circle the **two** drawings where tone has been **correctly** applied according to the light source indicated.

**a.**

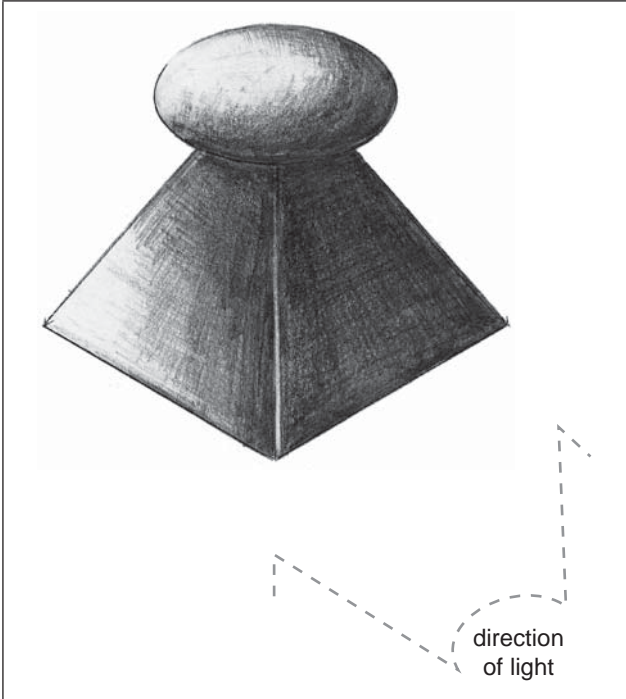

**b.**

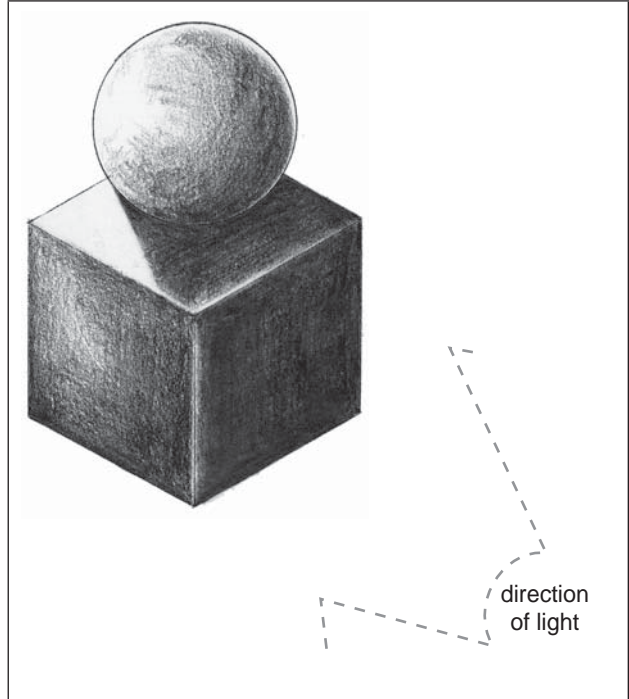

**c.**

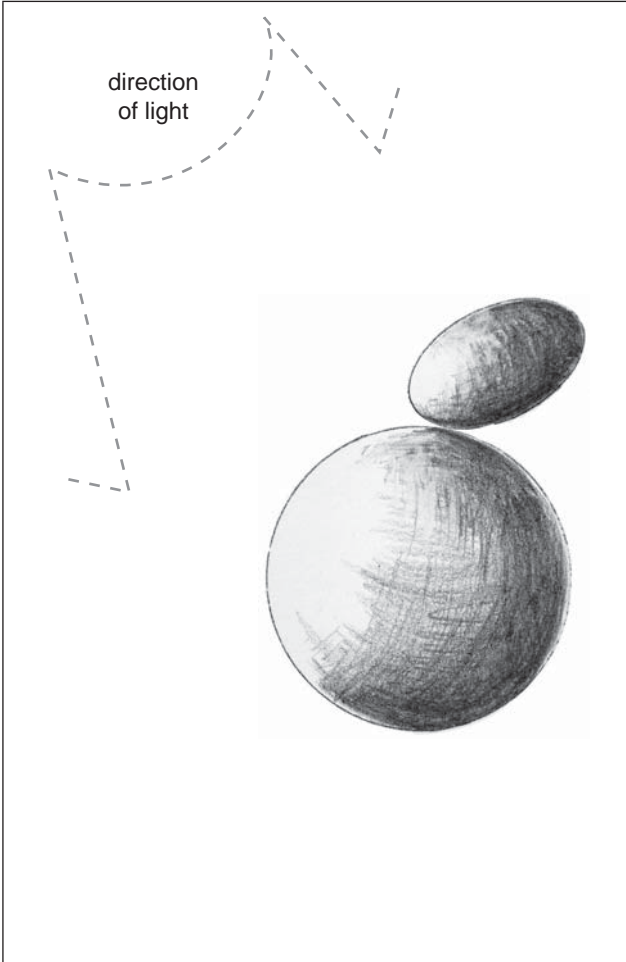

**d.**

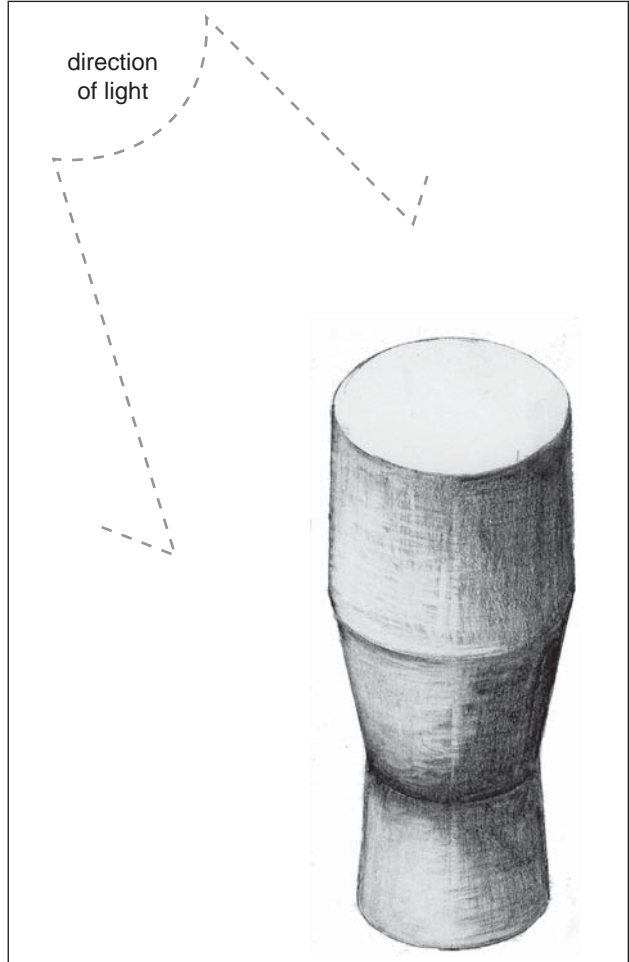

1 + 1 = 2 marks

**TURN OVER**

This page has been left blank for rough working space for development work.  
Work on this page will not be assessed.

**Question 3**

Using the **light source** indicated, render each shape with **tone** to enhance its three-dimensional form.

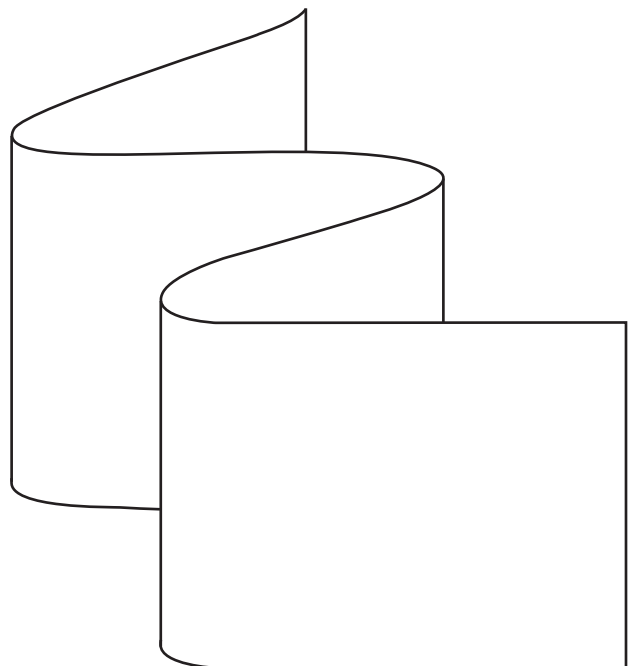
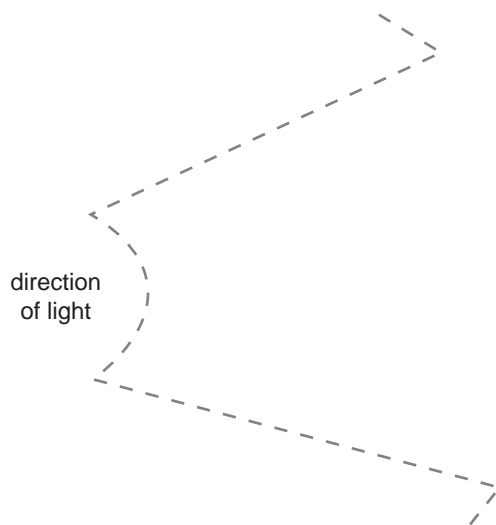
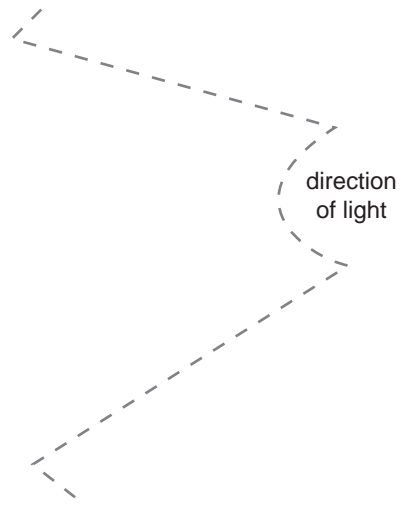
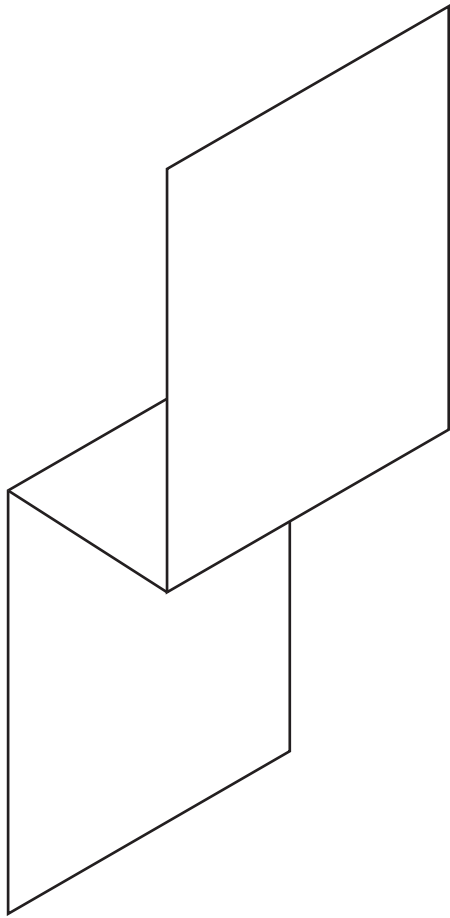

4 + 4 = 8 marks

**TURN OVER**

**Question 4**

Below is a sketch of a wooden block on a 10 mm isometric grid. On page 7, draw the third-angle orthogonal drawing of this block using the 10 mm grid given.

- arrow A indicates the front view
- include all hidden lines and centre lines according to the Australian Standards Association conventions
- include all labels and symbols according to the Australian Standards Association conventions

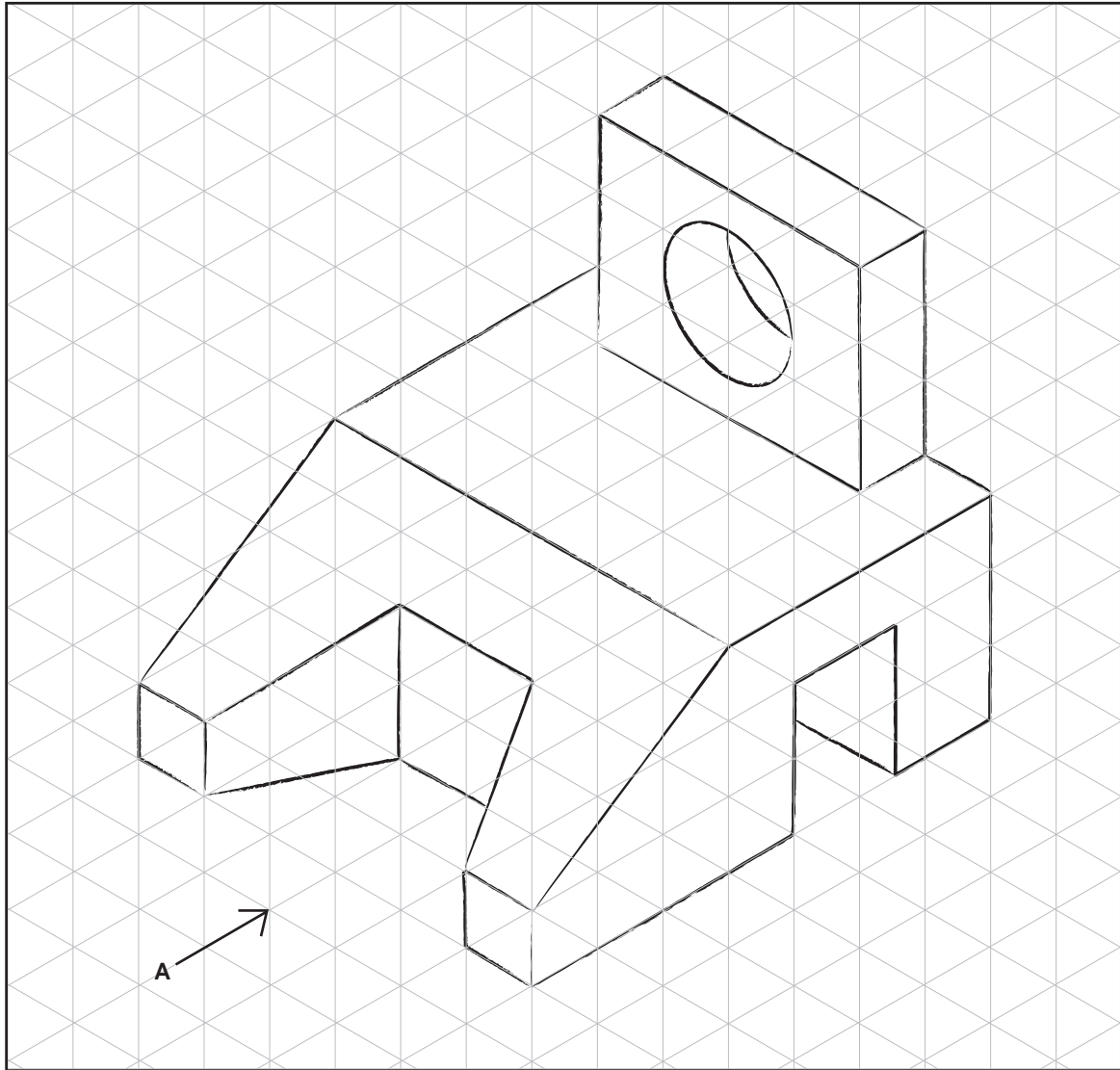



**Question 5**

**Figure 1**, on page 3 of the resource book, is a poster for a music concert.

You must answer all parts of this question in response to Figure 1.

- a. Identify the intended **purpose** of this poster.

\_\_\_\_\_ 1 mark

- b. Identify and describe one **dominant** design element and discuss how it has been used effectively in this design.

Element \_\_\_\_\_

Discussion \_\_\_\_\_

\_\_\_\_\_  
\_\_\_\_\_  
\_\_\_\_\_

1 + 2 = 3 marks

- c. Choose a **dominant** design principle which has been used in this poster. Evaluate its effectiveness in conveying information and/or ideas.

Principle \_\_\_\_\_

Evaluation \_\_\_\_\_

\_\_\_\_\_  
\_\_\_\_\_  
\_\_\_\_\_  
\_\_\_\_\_  
\_\_\_\_\_  
\_\_\_\_\_

1 + 3 = 4 marks



**Question 6**

**Figure 2**, on page 4 of the resource book, is a prototype of a cardboard bicycle design. The client required a cheap and ecologically friendly form of transport which would encourage commuters to cycle to work rather than drive a car.

The final design is made entirely from recycled materials. The bicycle is water resistant. It is lightweight and costs less than \$30 to purchase.

- a. Identify **two** characteristics of the target audience(s) for the bicycle design.

In your response discuss the reason(s) for your decision.

---

---

---

---

2 + 2 = 4 marks

- b. What decisions may the designer have considered in choosing materials during the design process?

---

---

---

---

---

3 marks

**Question 7**

In the resource book on pages 5–8 is a series of images showing the design process used by the illustrator Finlay Williams to produce a set of Christmas cards.

The client required

- five unique designs that needed to work together as a set in black and white
- a handmade and contemporary feel that would appeal to adults.

a. Identify four components of the design process undertaken by Finlay Williams.

1. \_\_\_\_\_
2. \_\_\_\_\_
3. \_\_\_\_\_
4. \_\_\_\_\_

4 marks

b. Describe two resources Finlay Williams may have used in the development of his ideas.

1. \_\_\_\_\_  
\_\_\_\_\_
2. \_\_\_\_\_  
\_\_\_\_\_

2 + 2 = 4 marks

c. Discuss two methods that Finlay Williams may have used to develop and refine his ideas. In your answer describe how he has used each method.

Method 1 \_\_\_\_\_

Description \_\_\_\_\_  
\_\_\_\_\_  
\_\_\_\_\_

Method 2 \_\_\_\_\_

Description \_\_\_\_\_  
\_\_\_\_\_  
\_\_\_\_\_

(1 + 2) + (1 + 2) = 6 marks

- d. Describe how Finlay Williams may have worked together with the following specialists during the design process.

Printer \_\_\_\_\_

\_\_\_\_\_

\_\_\_\_\_

\_\_\_\_\_

\_\_\_\_\_

Graphic designer \_\_\_\_\_

\_\_\_\_\_

\_\_\_\_\_

\_\_\_\_\_

\_\_\_\_\_

3 + 3 = 6 marks

**Question 8**

Shooting Star is a large observation wheel located on the waterfront of a major city. Each of the cabins carries up to 20 guests on a 30-minute ride. The view from each cabin during the ride provides guests with a panoramic view of the cityscape.

You are required to design a ticket that will be used to gain entry for a ride on the Shooting Star observation wheel. The ticket will be for one person. The layout found on page 13 defines the shape of the ticket and must be used for your final answer. You may use the answer space horizontally or vertically.

In your design you are required to use one or more of the following shapes to create imagery for the ticket. You may change the scale and proportion to suit your design. The shapes may be used in solid form or as an outline.

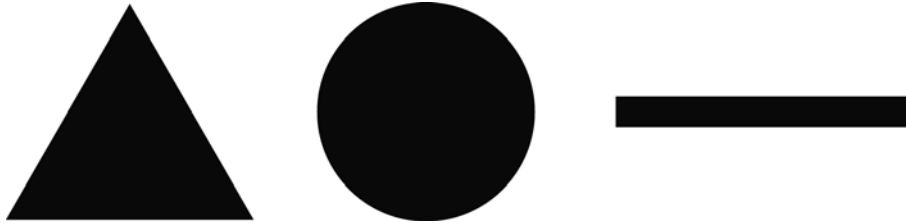

The design of the ticket must also

- include the text 'Shooting Star', 'Admit One' and the cost '\$15'
- use the element of colour to create the following hierarchy of information (title, images, cost)
- emphasise the principles of both cropping and pattern.

The images provided on pages 9–10 of the resource book may be used as inspiration.

(4 + 2 + 4) + 6 = 16 marks

working space

Complete your design for **Question 8** in the space provided below.

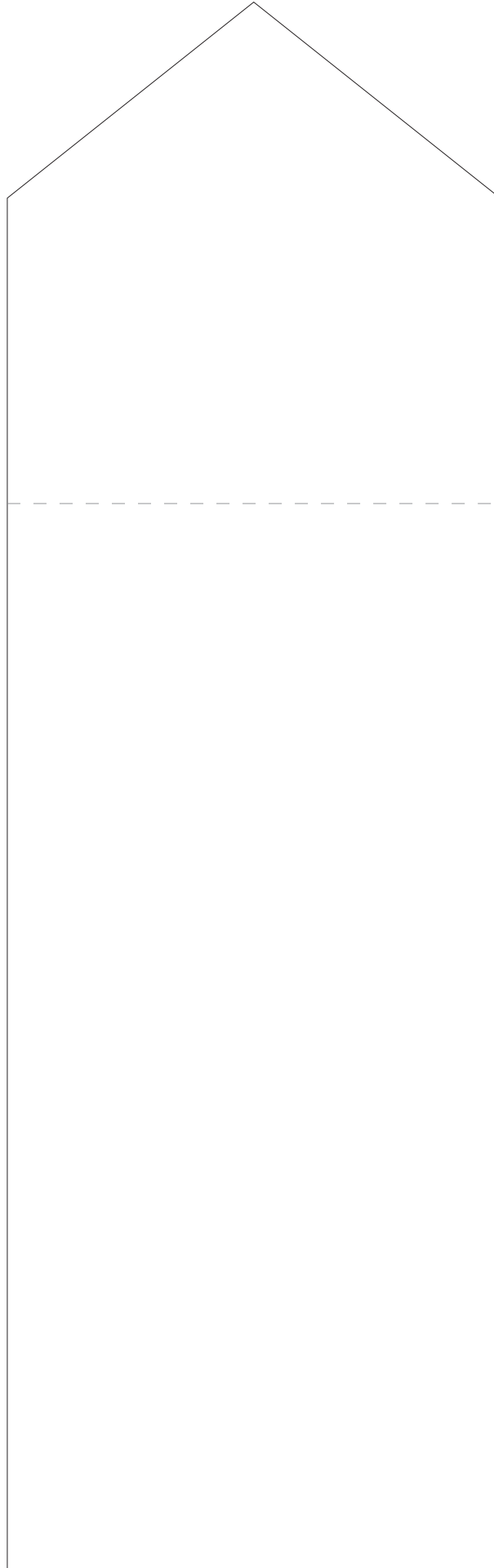

**TURN OVER**

Rough working space for development work  
Work on this page will not be assessed.

Rough working space for development work  
Work on this page will not be assessed.







**Victorian Certificate of Education  
2009**

**VISUAL COMMUNICATION AND DESIGN**

**Written examination**

**Tuesday 10 November 2009**

**Reading time: 11.45 am to 12.00 noon (15 minutes)**

**Writing time: 12.00 noon to 1.30 pm (1 hour 30 minutes)**

**RESOURCE BOOK**

**Instructions**

- A question and answer book is provided with this resource book.
- Refer to instructions on the front cover of the question and answer book.
- You may keep this resource book.

**Students are NOT permitted to bring mobile phones and/or any other unauthorised electronic devices into the examination room.**

**This page is blank**

**Reference material for Question 5**

Due to copyright restriction,  
this material is not supplied.

**Figure 1**

Reference material for Question 6

Citycycle bicycle

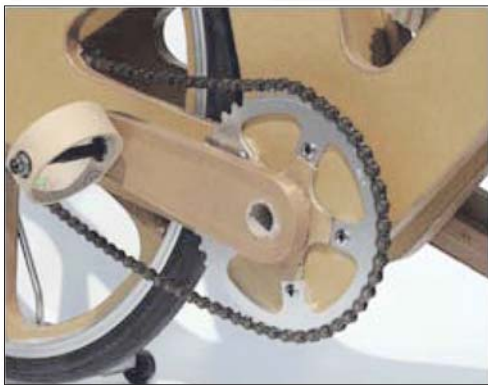

Material: lightweight recycled cardboard  
Cost: under \$30

Figure 2

<b>Reference material for Question 7</b>
--

Due to copyright restriction,  
this material is not supplied.

Reference material for Question 7

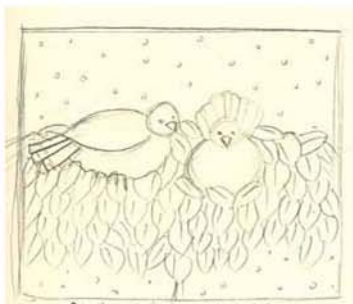
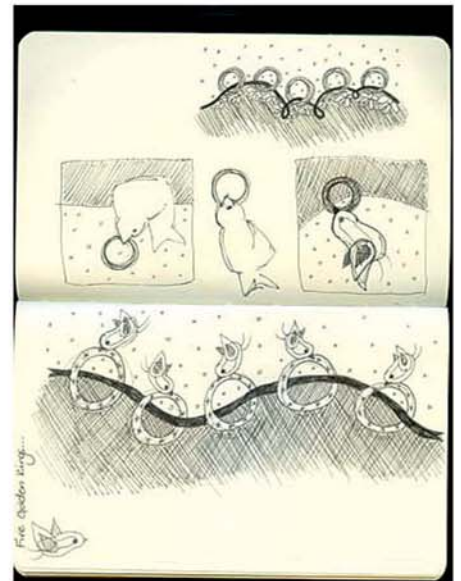
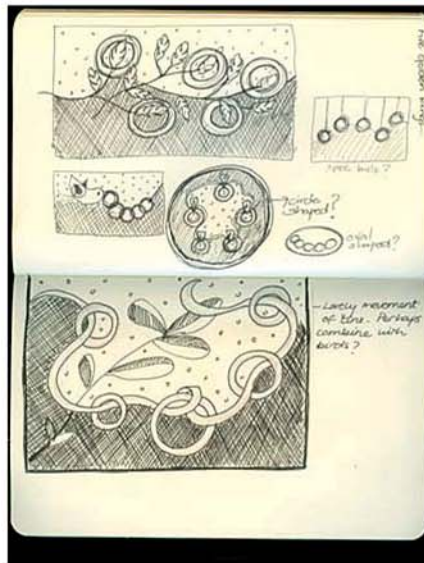
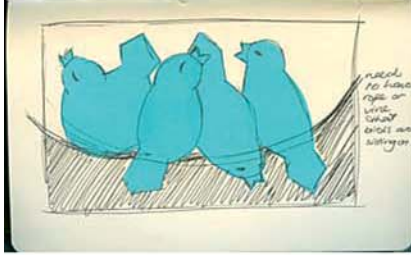
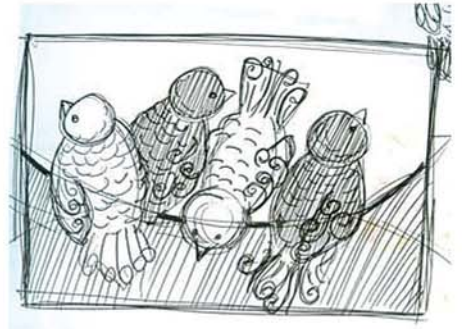
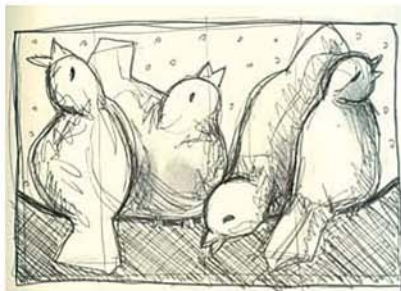
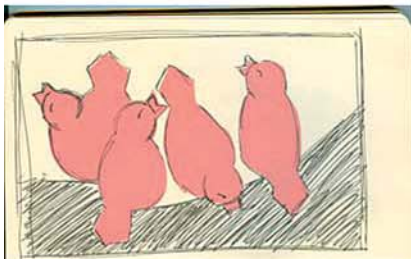
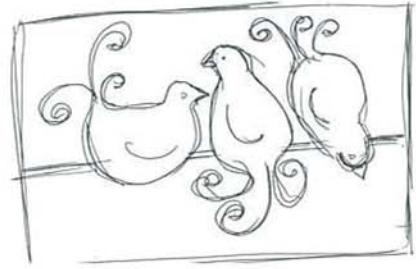

Reference material for Question 7

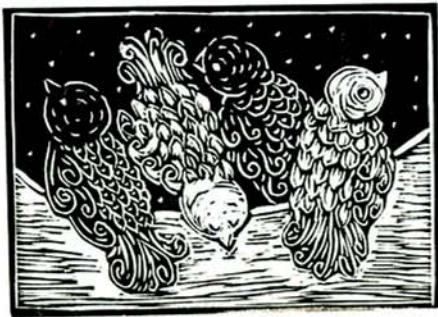

Reference material for Question 7





Reference material for Question 8

Images of an observation wheel



observation wheel cabin

Reference material for Question 8

AaBbCcDdEeFfGgHhIiJjKkLlMmNnOo  
PpQqRrSsTtUuVvWwXxYyZz

**AaBbCcDdEeFfGgHhIiJjKkLl**

**MmNnOoPpQqRrSsTtUuVv**

**WwXxYyZz**

*abcdefghijklmnopqrstuvwxyz*

S s

**AaBbCcDdEeFfGgHh  
IiJjKkLlMmNnOoPp  
QqRrSsTtUuVvWwXx  
YyZz**

AaBbCcDdEeFfGgHhIiJjKkLlMmNnOoPpQqRr  
SsTtUuVvWwXxYyZz

**abcdefghijklmnopqrstuvwxyz**

a b c d e f g h i j k l m  
n o p q r s t u v w x y z

