

# Visualization for Engineers and Scientists

An Engineering Graphics Text for Design Programs

**Second Edition**

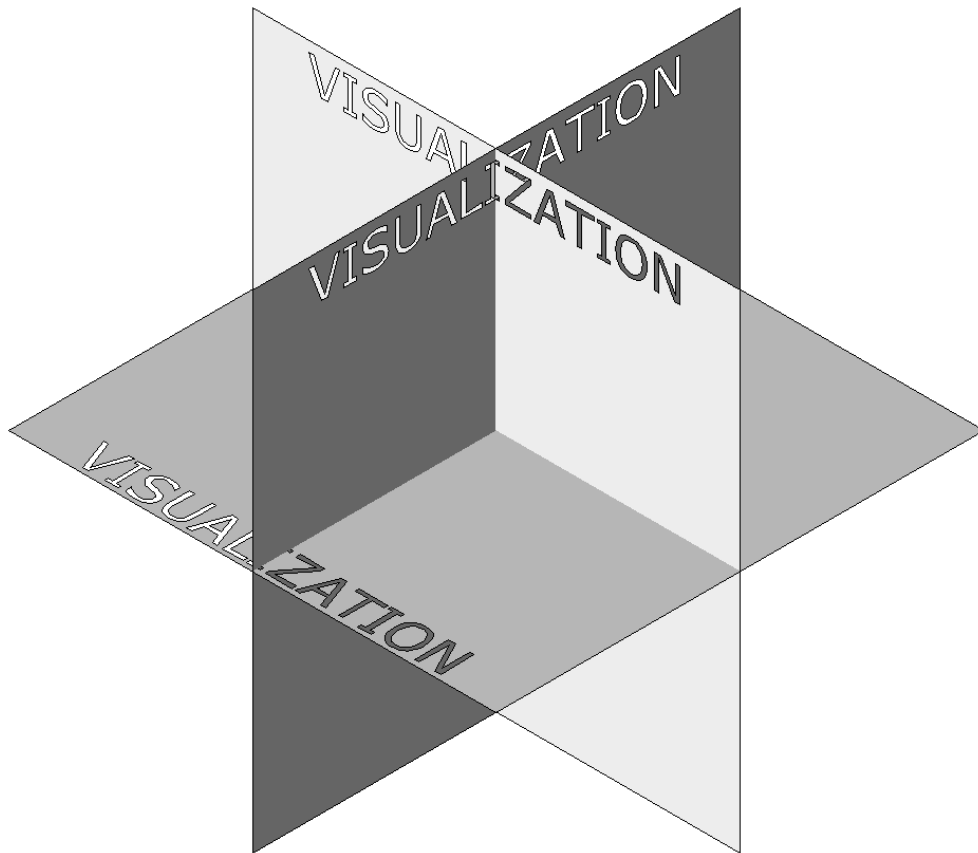

**Ted Smathers**  
Colorado School of Mines

**SDC**  
PUBLICATIONS

[www.SDCpublications.com](http://www.SDCpublications.com)

Schroff Development Corporation

## Orthographic Views and Multi-View Sketching

*Orthographic sketching presents views in a two dimensional form. Isometric sketching is used when you want to present your ideas in a three dimensional form. This chapter will present the concepts to allow you to communicate your ideas and design in the appropriate manner.*

We are familiar with two dimensional drawings and designs that utilize an X-Y coordinate system. The two dimensional drawing presents a planar view that lends itself to the two dimensional paper used to visualize the design. If we want to show a three dimensional view of a design, we need to have techniques that allow us to present three dimensional information on two dimensional paper. The coordinate systems available to us assist in the way we wish to communicate designs.

### Coordinate Systems

When we wish to present an engineering sketch that is two dimensional, we can use orthographic paper to present the idea. *Ortho* means at right angles or normal to each other. Thus we may use paper having an orthographic grid to represent planar views.

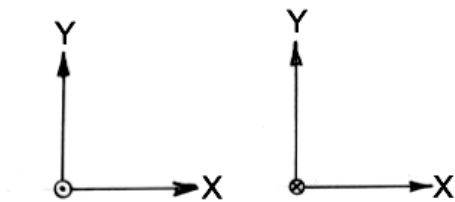

There indeed is a third axis, the Z axis, that is normal to the X and Y axis, or normal to the plane of the paper. The dot indicates that the Z axis is coming out of the paper; the x indicates the Z axis is going into the paper

Figure 3-1 Orthographic coordinate system

## VISUALIZATION FOR ENGINEERS AND SCIENTISTS

The X axis and Y axis are shown in the positive direction. We need to determine if the Z axis is positive going into the paper or coming out of the paper.

The so called right hand rule will address this. There are many problems in engineering, physics, optics, and magnetics that utilize the right hand rule for solution to problems. We will use the right hand to determine the direction of the Z axis when the X and Y axis are known, or when any two of the three directions are known.

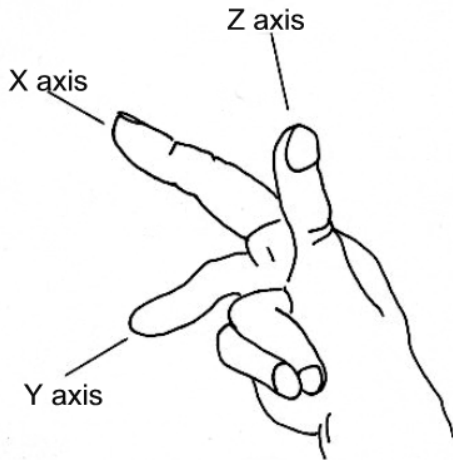

Figure 3-2 The right hand rule

Consider the right hand shown in Figure 3-2. Position your thumb, forefinger, and middle finger at right angles as shown. This will determine the directions of the mutually perpendicular axes. The forefinger will show the direction of the **X-Axis**, the middle finger will show the direction of the **Y-Axis**, and the thumb will show the direction of the **Z-Axis**.

All directions shown are in the **positive** direction.

The right hand rule shows the relationship of the axes constant regardless which way the axes system is oriented. In this manner, a three dimensional axes system can be represented on two dimensional paper. The axes system of Figure 3-3 are all equivalent.

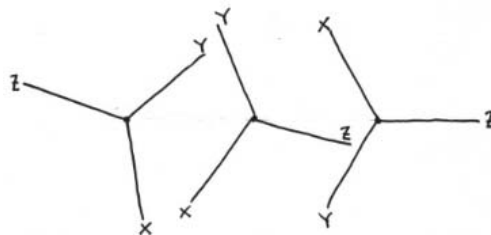

Figure 3-3 Equivalent coordinate systems

For our purposes, we will consider the positive Y-axis to be vertical on orthographic paper, the X-axis to be positive to the right, and the Z-axis positive coming out of the paper.

## ORTHOGRAPHIC VIEWS AND MULTI-VIEW SKETCHING

There are several ways an object may be visualized, which implies there may be several ways to sketch the object. Consider the following box (Figure 3-4) that has one corner removed.

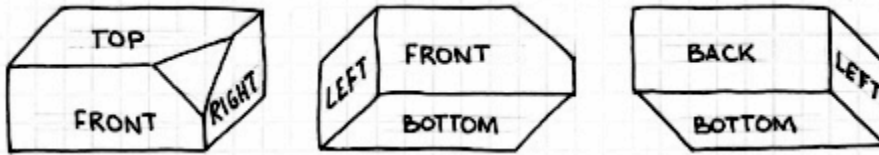

Figure 3-4 Different orientations of an object

On any given orientation (and there are many more than shown), we see three surfaces of the box. There are actually six views if we look normal to each surface—1) the front side, 2) the right side, 3) the topside, 4) the bottom, 5) the back side, and 6) the left side. To be somewhat standard in the way an object is visualized, the views considered the three principal views are the **Top**, **Front**, and **Right Side** views. There may be circumstances that require other views, but we will consider these three views to be the ones that describe a part.

The front, top, and right side views are related to each other when you consider each view orthogonal to each other. As such, the placement of the views is set by convention. These views are normal to each other and are called **orthographic** views.

The front view should show the most characteristic shape or features of the object. The front view also shows the most salient features of the object and as such has the fewest number of hidden lines.

Consider the solid object shown in a three dimensional view in Figure 3-5. To create orthographic views of this object, we must look at the object in a view that is perpendicular to the front, top, or right side.

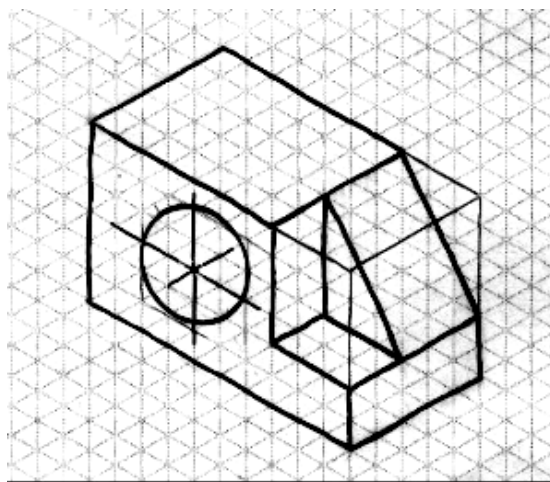

Figure 3-5 Three dimensional view

Consider this object to be in a rectangular box that allows us to see inside the box. Figure 3-6 shows this box oriented in a three dimensional axes system.

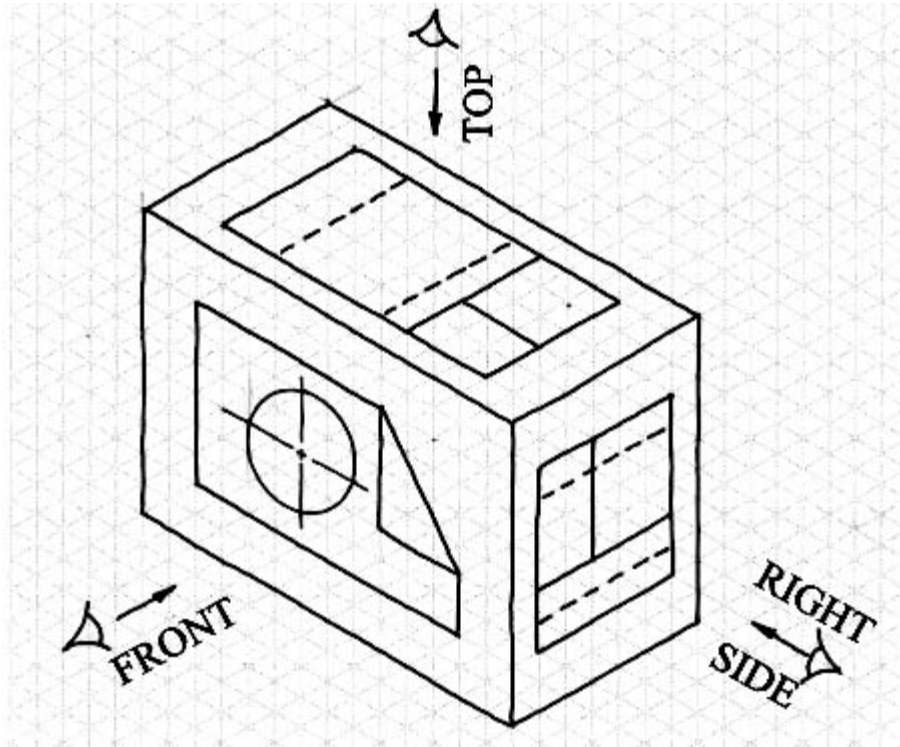

Figure 3-6 Views projected on sides of box

Visualize the surfaces projected onto the sides of the box. The eyeball representation looks at the resultant two dimensional views. The Front View is in the X-Y plane; the top view is in the X-Z plane; and the right side view is in the Y-Z plane. All the views are related and all the views are in pre-determined positions. The three views shown represent the three principal views that are orthogonal to each other. Each view provides information about the object, summarized by the following table.

View	Information Provided
Top	Width and Depth
Front	Height and Width
Right Side	Height and Depth

Table 3-1 Attributes of each view

## ORTHOGRAPHIC VIEWS AND MULTI-VIEW SKETCHING

The position of the top, front, and right side views are pre-determined. Consider Figure 3-7. If the paper on which the views are shown is folded  $90^\circ$  as shown, each view would be orthogonal to each other. The rectangular box of Figure 3-6 would be replicated.

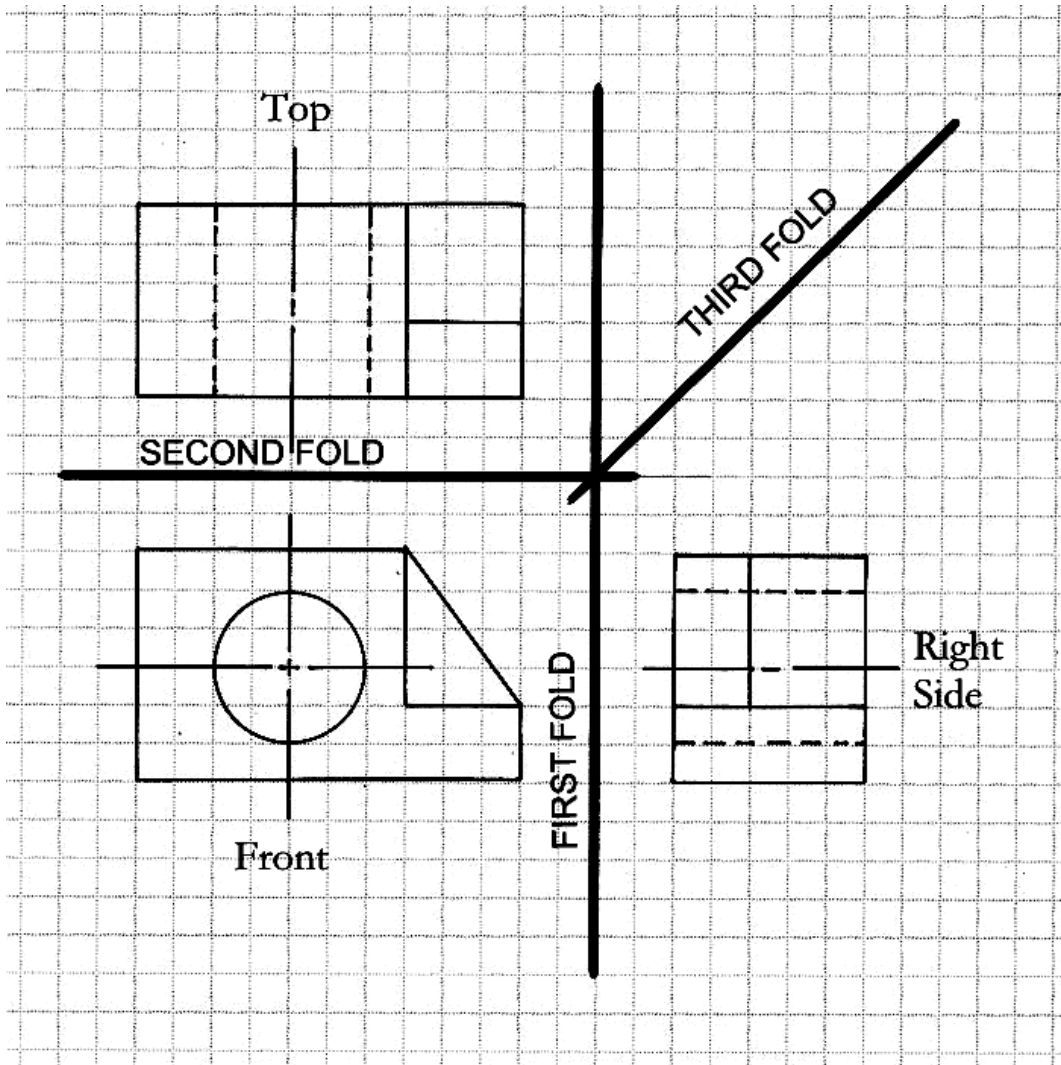

Figure 3-7 Orthogonal relationship of three views.

Figure 3-7 introduces two features common to the orthographic views: hidden lines and centerlines. The hidden line is used to show a feature that is present in the object, but not in the surface of the particular view. The front view clearly shows the hole with its centerlines, but the other two views must show this hole by hidden lines and its centerline. The hidden lines are shown as a series of dashes as shown. Hidden lines are part of the orthographic sketching process.

The positions of the three principal views are defined because the views are orthogonal to each other. Each view must be aligned with every other view. Each feature of a given view can be projected to another view. Figure 3-8 shows every feature projected orthogonally to every view. This projection is the basis of creating a third view when two views are known.

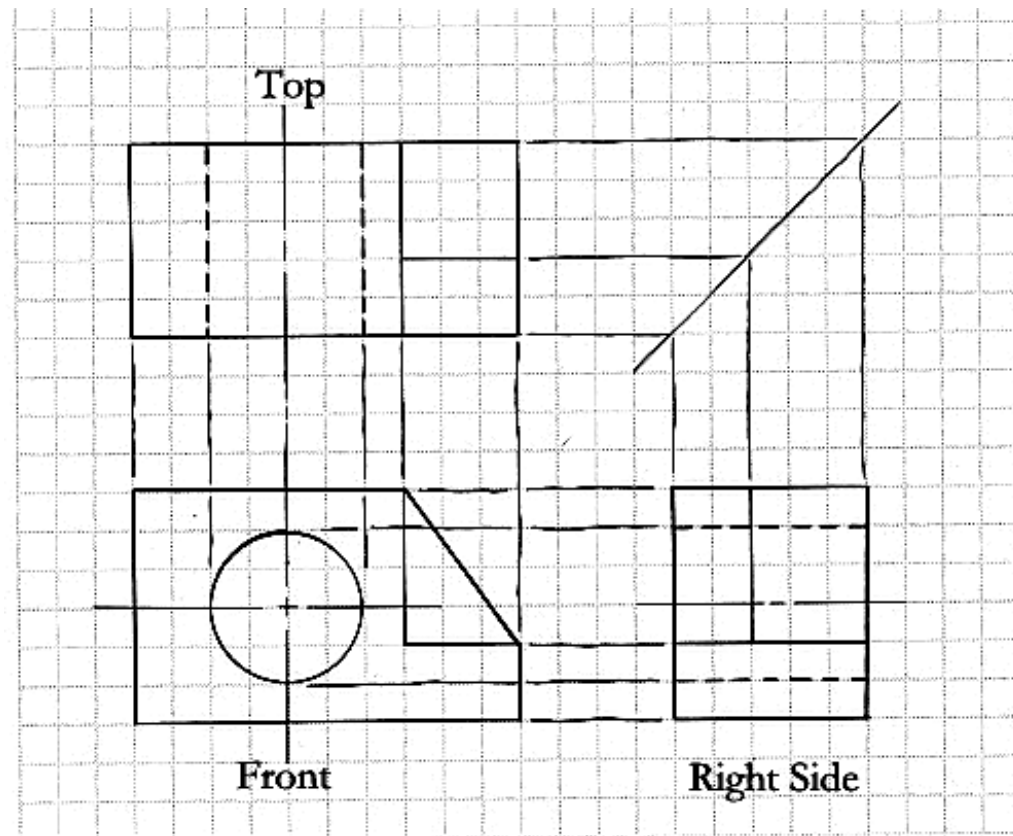

Figure 3-8 Alignment of orthographic views

The three principal views are used to describe an object. Other views may be required to completely define what an object looks like. Perhaps you wish to visualize the object in some different plane. There are six possible views that can be associated with any object, plus auxiliary views that look normal to any plane of interest. Drawings or sketches that use several views are called multi-view drawings.

## ORTHOGRAPHIC VIEWS AND MULTI-VIEW SKETCHING

### Multi-View Sketches

The six possible views of the described object are shown in Figure 3-9. All views are orthogonal to each other. The location of each view is fixed because the views are all normal or orthographic to each other. Locations are not arbitrary; they are fixed.

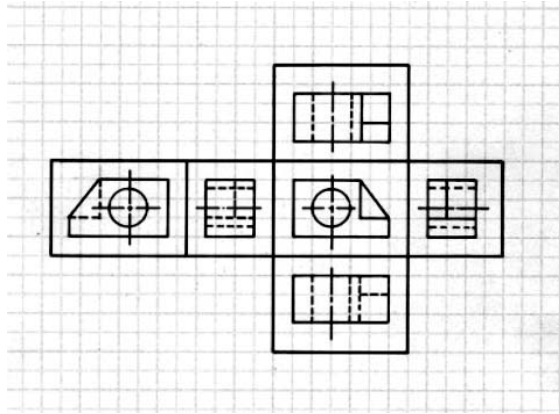
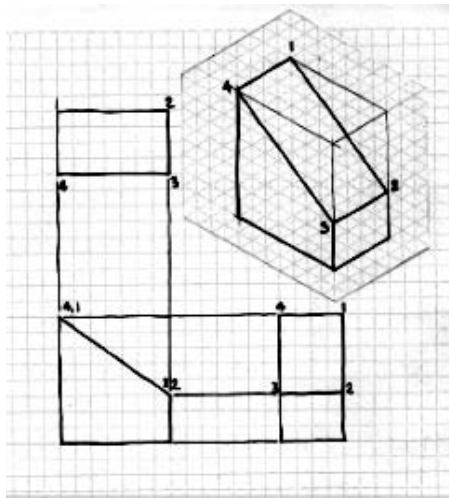

Figure 3-9 Six orthographic views

If you have two views of an object, the third view can be constructed from the information from the other two. Lines that are missing from one view can be constructed from the information available in other related views. It may be helpful to identify particular features from one view as the feature appears in another view. Figures 3-10 and 3-11 show this.



Top view provides width and depth information; front view gives width and height; right side gives height and depth.

Figure 3-10 Identification of features



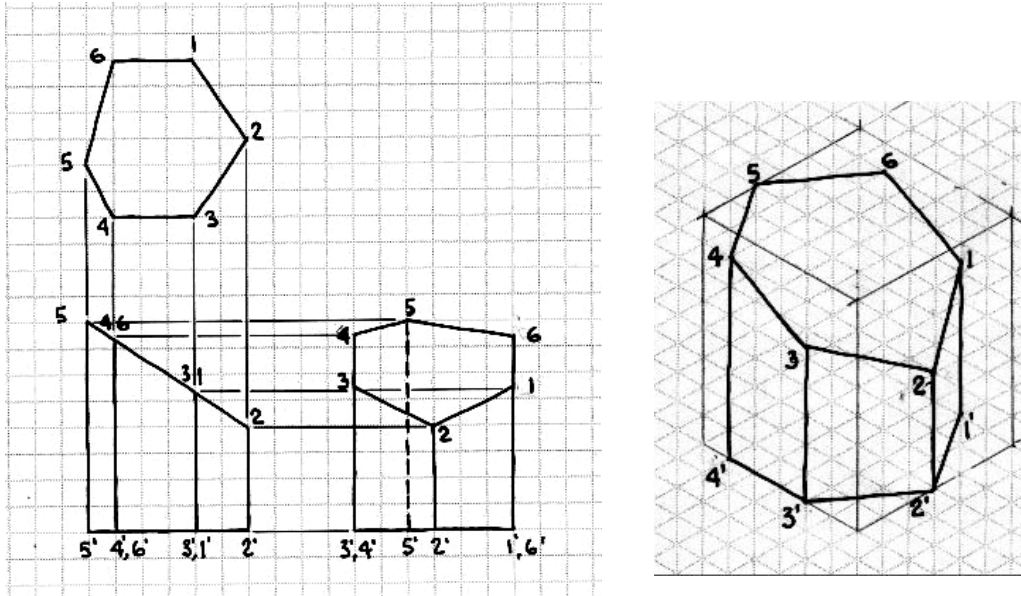
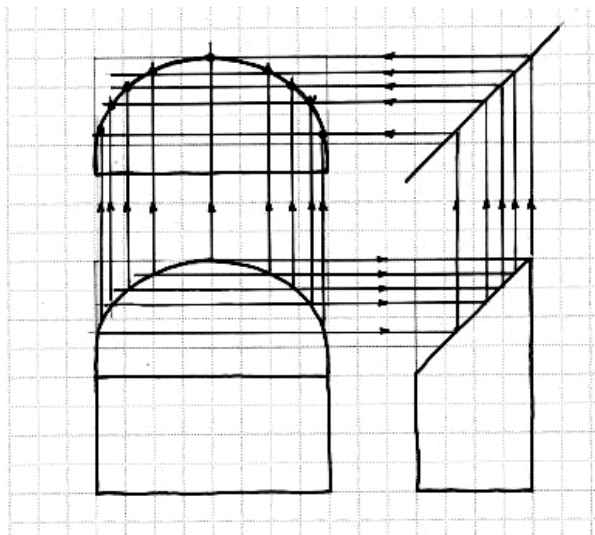

Figure 3-11 More feature identifications

Circular objects are treated in the same manner to visualize different views. Specific locations on one view can be projected to another view. Orthographic projection makes this possible.



Arbitrary points can be selected on the front view and projected to the top view. Likewise, points on the front view can be projected to the right side view to the top view.

Figure 3-12 Orthographic projection of a circular shape

## ORTHOGRAPHIC VIEWS AND MULTI-VIEW SKETCHING

### Problem Set

3-1 Complete the multi-view drawing by sketching the Right Side view.

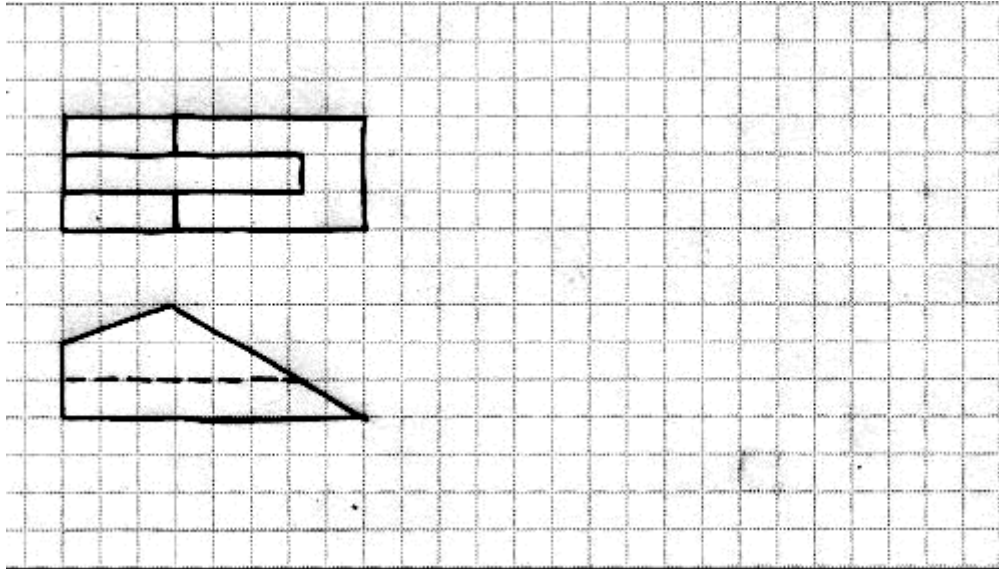

3-2 Complete the multi-view drawing by sketching the Top View.

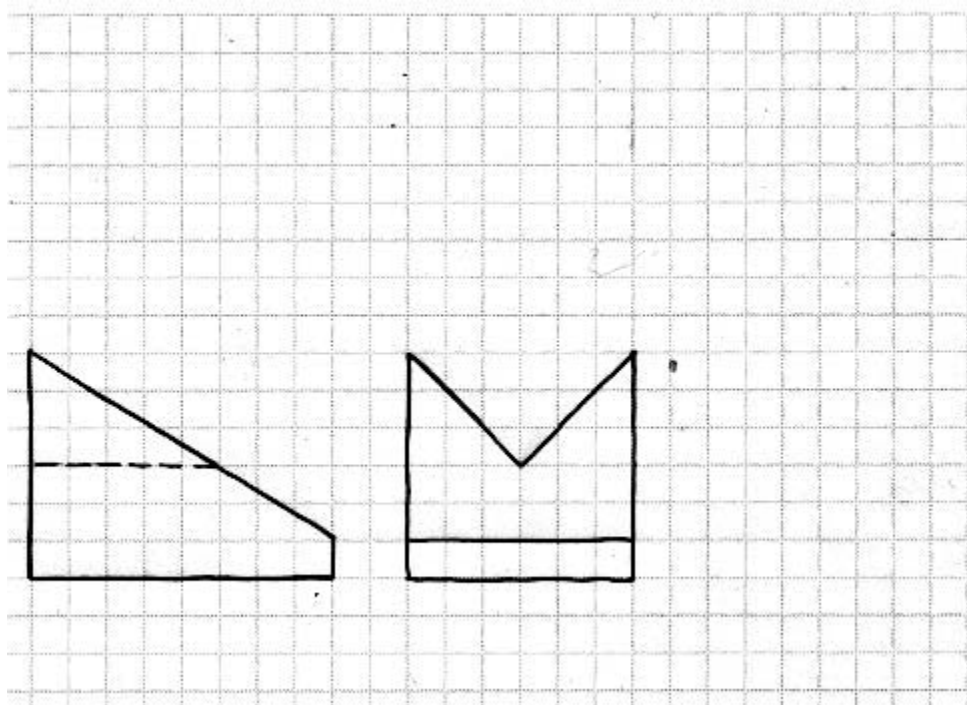

**NOTES:**

## ORTHOGRAPHIC VIEWS AND MULTI-VIEW SKETCHING

3-3 Complete the multi-view drawing by adding the line missing from the top view and the right side view.

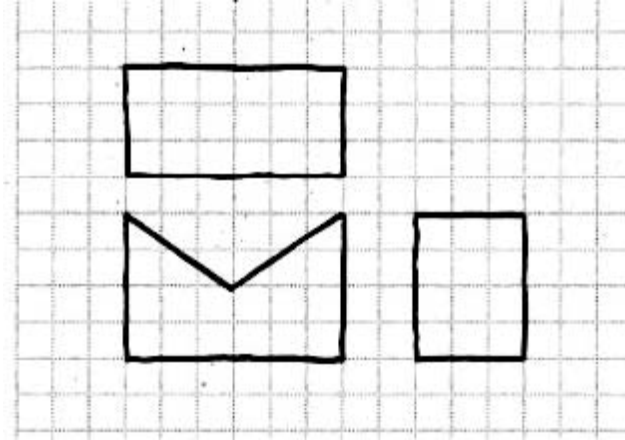

3-4 Complete the multi-view drawing by adding the line(s) missing from the right side view.

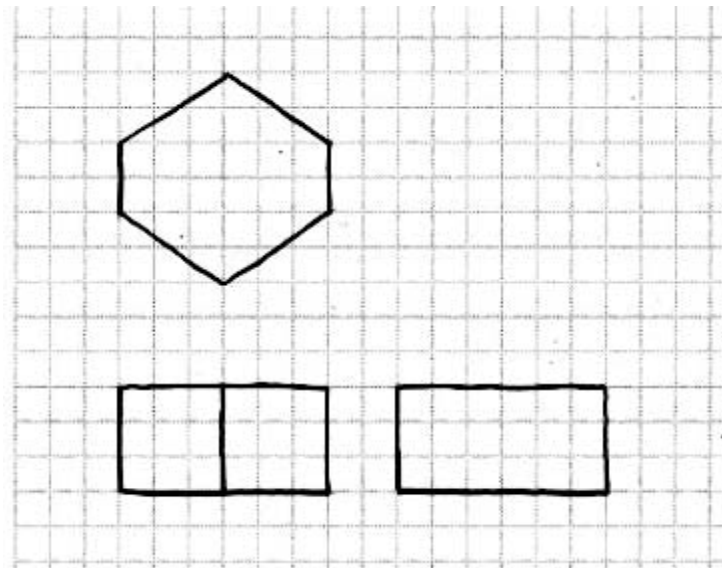

**NOTES:**

## ORTHOGRAPHIC VIEWS AND MULTI-VIEW SKETCHING

3-5 Add the missing line to the appropriate view.

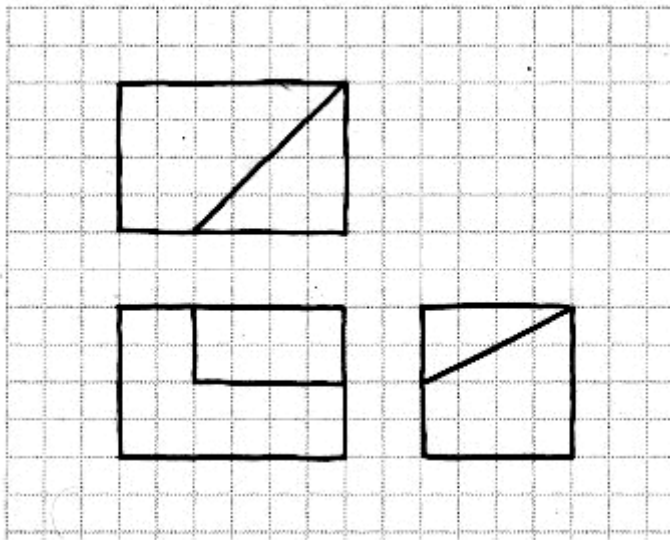

3-6 Add the missing line(s) to the appropriate view(s).

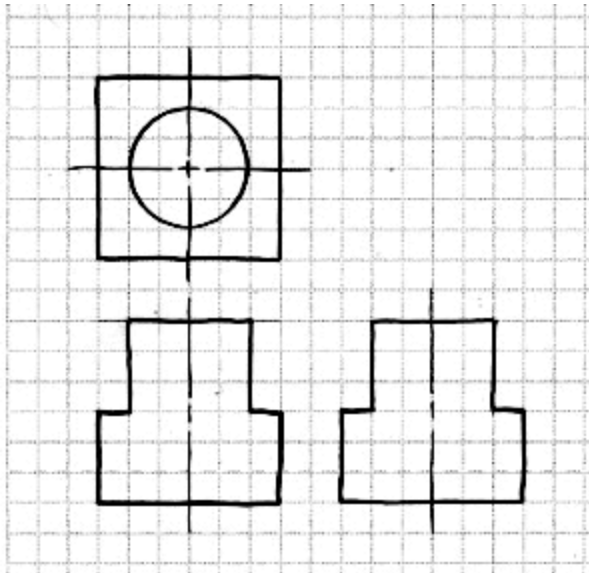

**NOTES:**

## ORTHOGRAPHIC VIEWS AND MULTI-VIEW SKETCHING

3-7 Sketch the top view of the multi-view drawing.

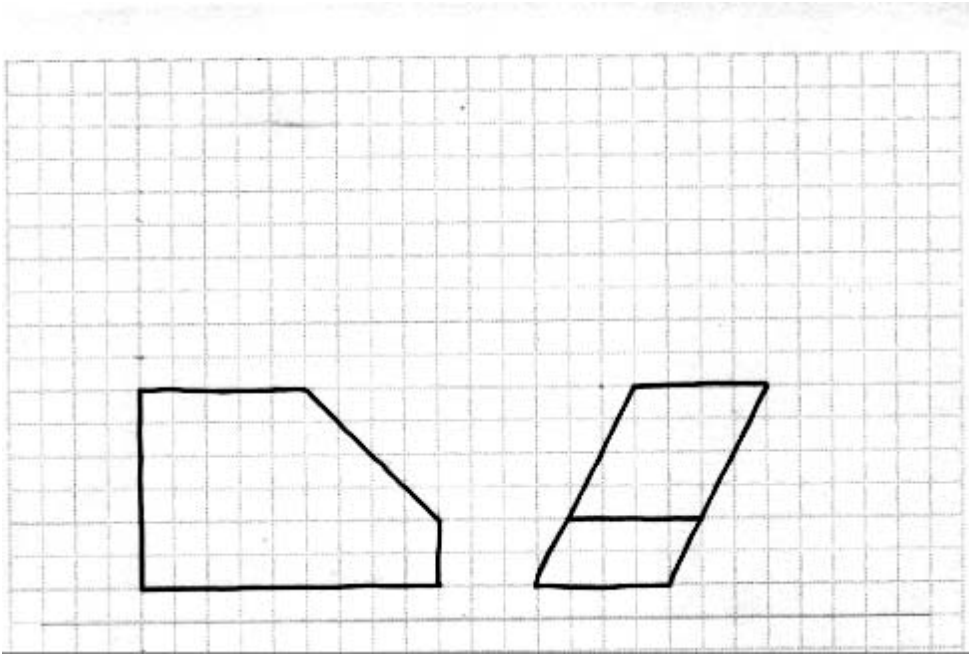

3-8 Sketch the top view of the multi-view drawing

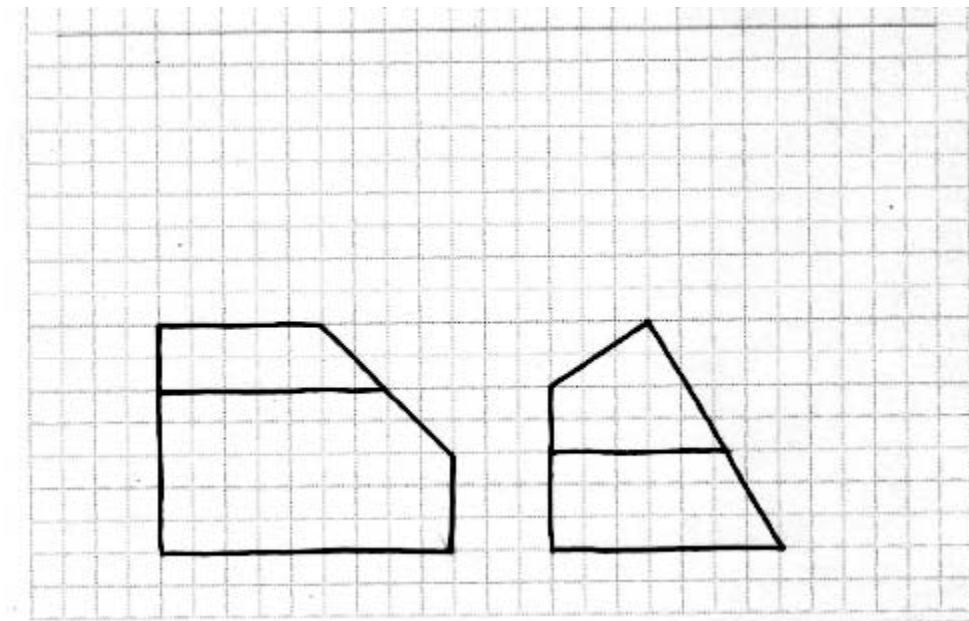



**NOTES:**

## ORTHOGRAPHIC VIEWS AND MULTI-VIEW SKETCHING

3-9 Sketch the right side of the multi-view drawing.

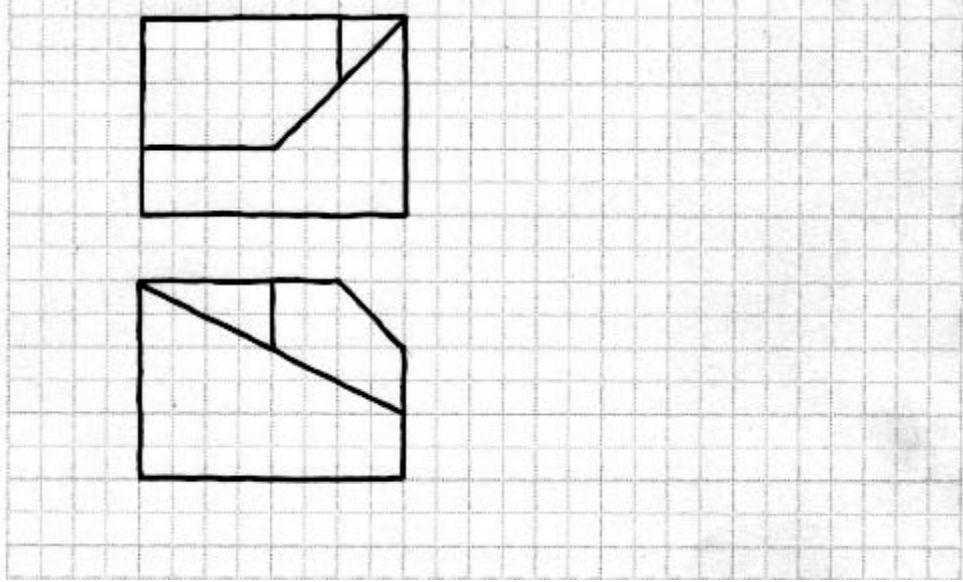

3-10 Sketch the right side of the multi-view drawing.

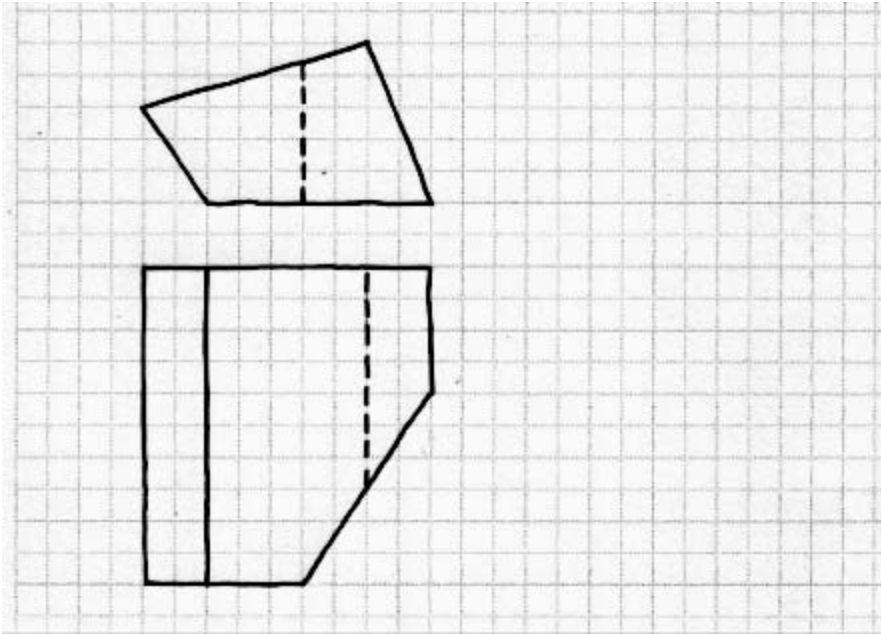

**NOTES:**

## ORTHOGRAPHIC VIEWS AND MULTI-VIEW SKETCHING

3-11 Sketch the right side of the multi-view drawing.

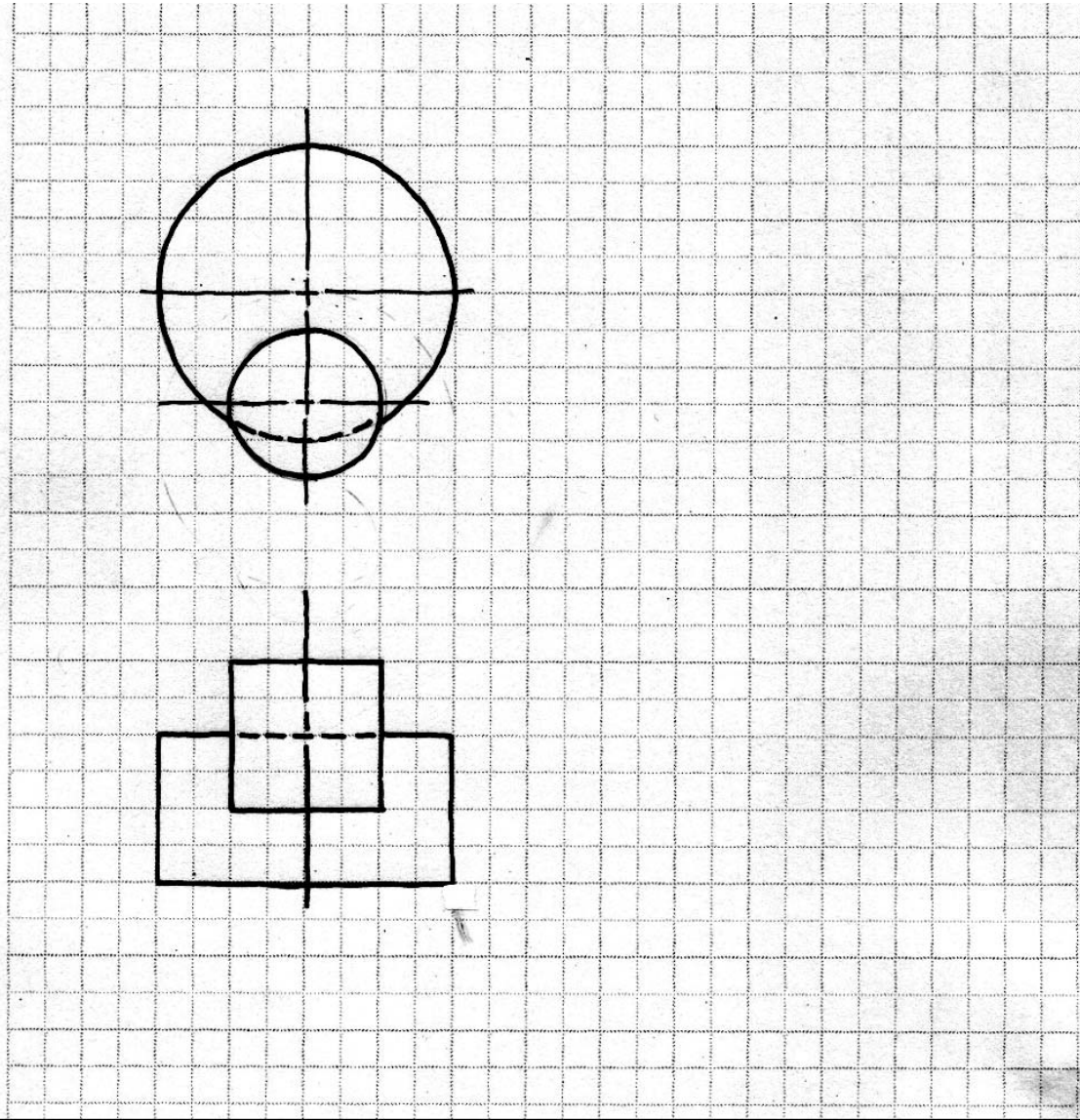

**NOTES:**

## ORTHOGRAPHIC VIEWS AND MULTI-VIEW SKETCHING

3-12 Sketch the top view of this multi-view drawing.

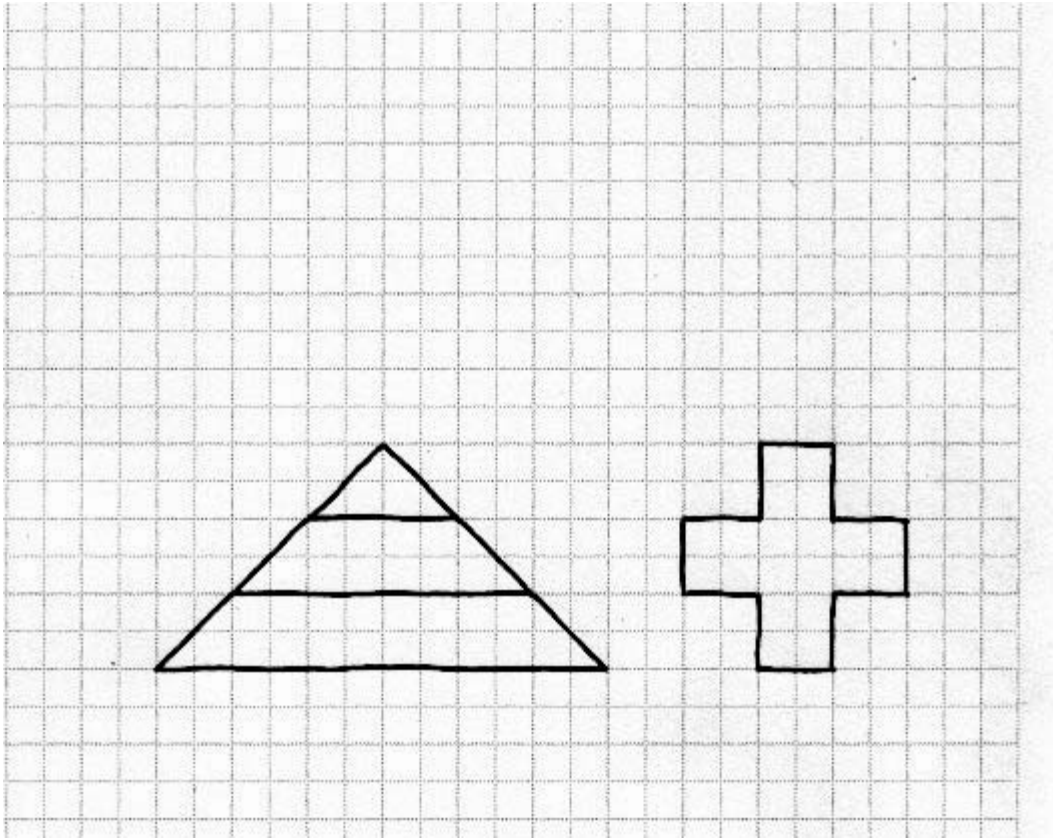

3-13 Complete the right side view by adding the lines that are missing.

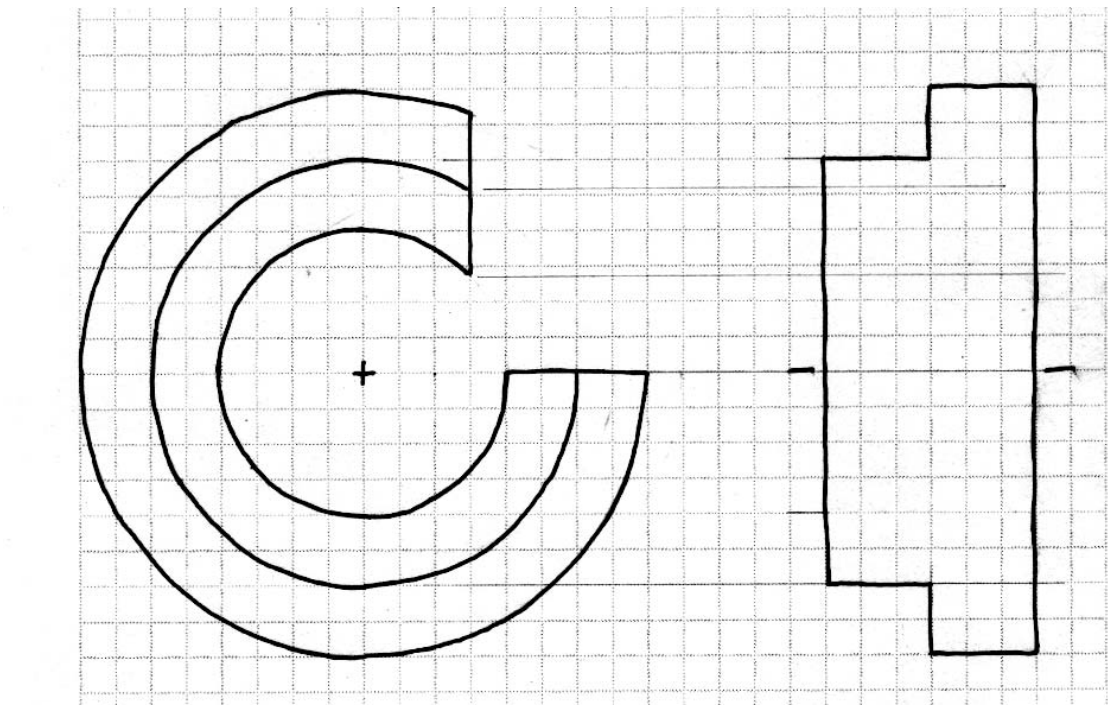

**NOTES:**

# ORTHOGRAPHIC VIEWS AND MULTI-VIEW SKETCHING

3-14 Given the Front View and the Right side views, Sketch the Top view.

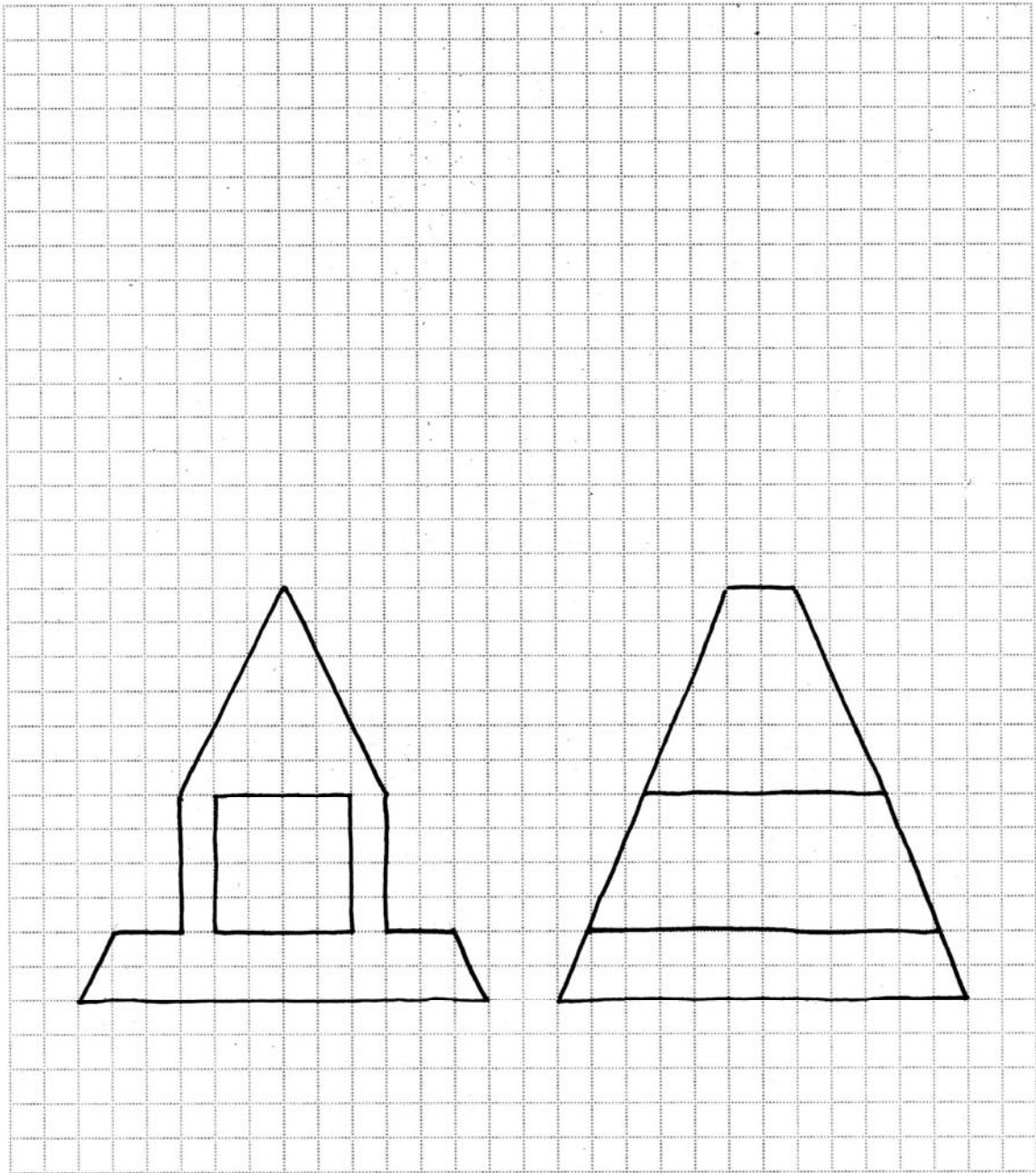

DRAWN BY		SECTION	DATE
SCALE	MATERIAL	TOLERANCE	
PART NAME			



**NOTES:**

# ORTHOGRAPHIC VIEWS AND MULTI-VIEW SKETCHING

3-15 Sketch the Right Side view of this multi-view drawing.

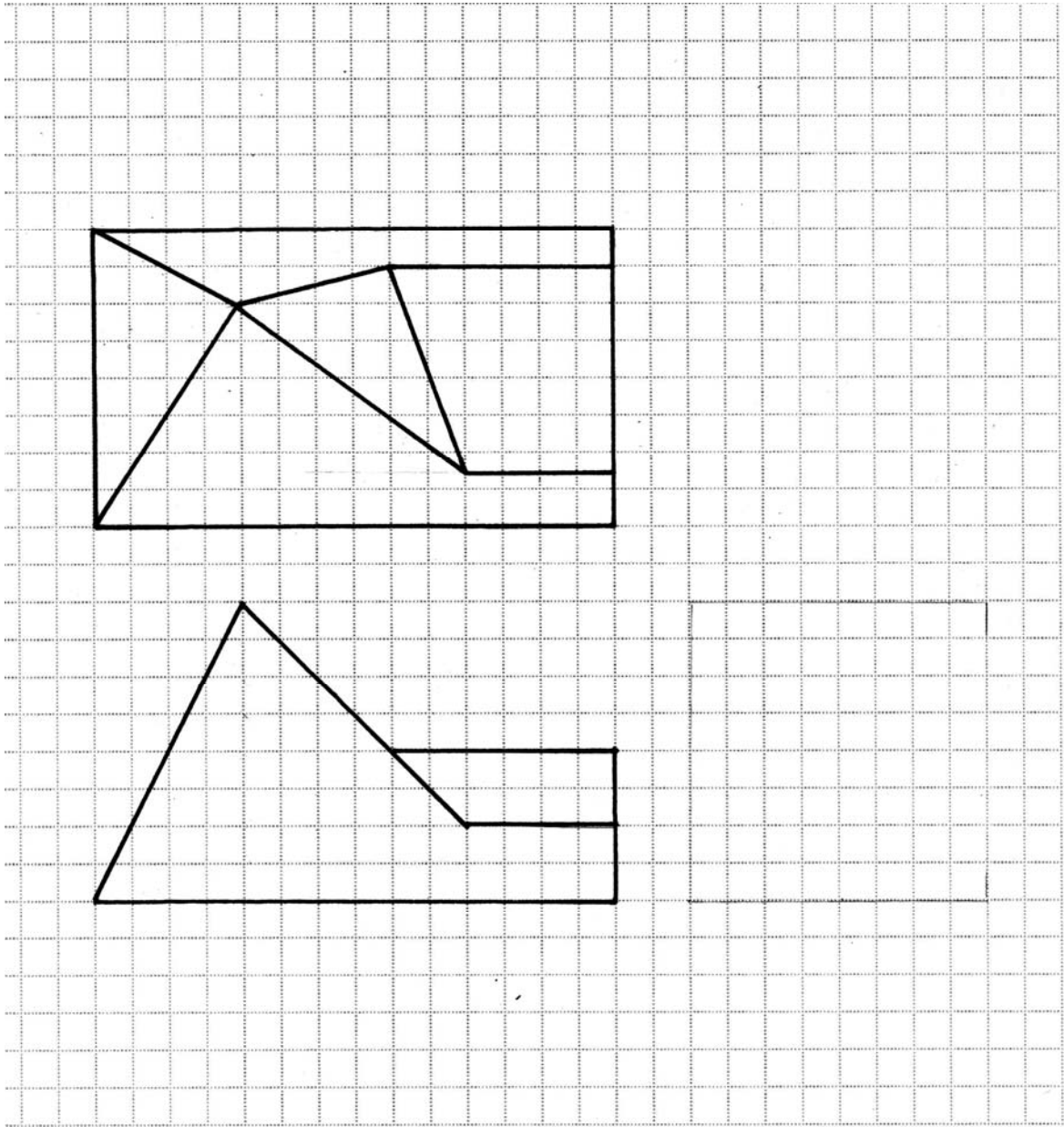

DRAWN BY		SECTION	DATE
SCALE	MATERIAL	TOLERANCE	
PART NAME			

**NOTES:**

## More Multi-View Drawings

**Auxiliary Views:** another way to visualize an object using techniques we have learned. An auxiliary view will provide additional dimensional information.

The three principal views will provide dimensional information. If you are perpendicular to a surface or a feature, the dimensional information you observe will be the true dimensional size. Conversely, if you do not observe a surface or feature normal to it, the dimensional information is not true. The auxiliary view will be used to get the true shapes. Consider Figure 3-12. We will utilize the orthographic knowledge we have to sketch the true size of the angled surface.

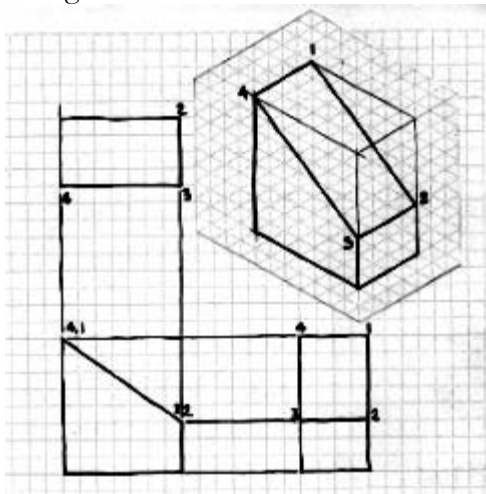

Figure 3-12 Orthographic views

This object is shown with the three orthographic views: top, front, and right side. None of the orthographic views show, however, the true size or shape of the angled plane 1,2,3,4. From the top view or right side view, we deduce by counting the squares that the size of line 1-4 or 2-3 is 4 units. We cannot deduce what the true dimension 1-2 or 3-4 is unless we look perpendicular to the surface.

To look at surface 1,2,3,4, from a perpendicular viewpoint, consider looking at the surface through a plane that is some uniform distance from the surface. Call this plane a *reference plane* because this plane will also be used in other views. See Figure 3-13.

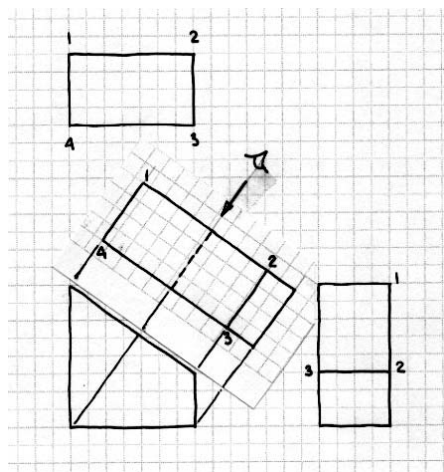

Figure 3-13 Auxiliary view of slanted surface.

Our eyeball is looking at the surface 1,2,3,4 in a perpendicular manner. We can therefore see the surface in its true shape. All the features are projected from the front view to this new view which is called an **Auxiliary View**.

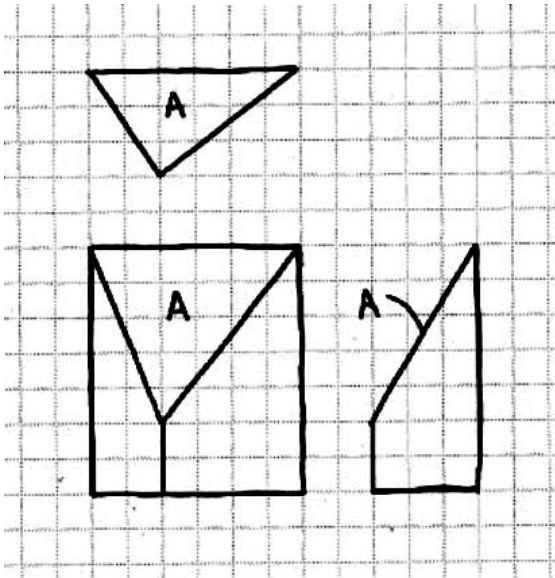

Figure 3-14 shows another object with its three principal orthographic views. The triangular surface marked A is not normal to any of the orthographic views. It is not possible to determine the true size of A from just the front, top, and right size views. In this situation, if we wish to know the true size and shape of surface A, we must look through a reference plane normal to the surface.

Figure 3-14 Orthographic views

To look normal to the surface A., construct a plane some distance away from the surface and a uniform distance from the surface. The right side view will show the edge of this plane, which is the reference plane. Figure 3-15 shows this.

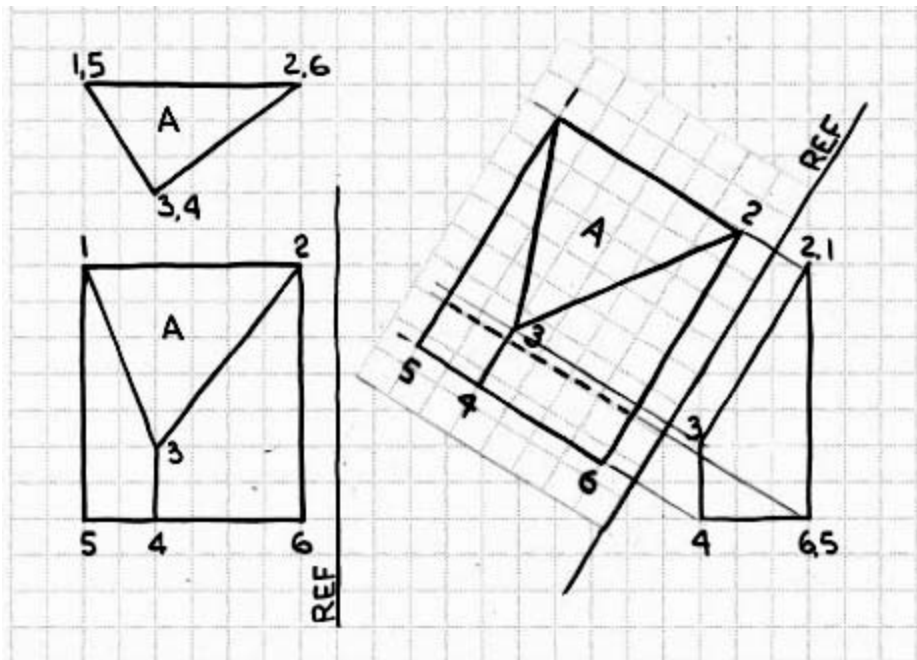

Figure 3-15 Orthographic views with an auxiliary view for surface A.

## ORTHOGRAPHIC VIEWS AND MULTI-VIEW SKETCHING

Figure 3-15 shows the position of the reference plane. It is placed an arbitrary distance away from the surface, in this case one block away. The reference plane is associated with the right side view, which provides height and depth information to us. We need width information to complete the auxiliary view. Width information is provided in the front view and the top view. For convenience, use the front view and move the reference plane parallel to an edge as shown *at the same distance away as in the right side view*. Points 1-2-3 can be projected into the auxiliary view. The distance from the reference plane (width information) is found from the front view and the reference plane there. Point 1 is seven units from the reference plane in the front view; hence it is seven units also from the reference plane in the auxiliary view. Point 3 is five units away from the reference plane; point 2 is one unit away. All the points can be determined in like fashion and the auxiliary plane can be completed. This will give the true size of surface A, plus the other features that are part of the object.

Another example is shown in Figures 3-16 and 3-17. In this case, the true shape of a curved surface is determined by the auxiliary view.

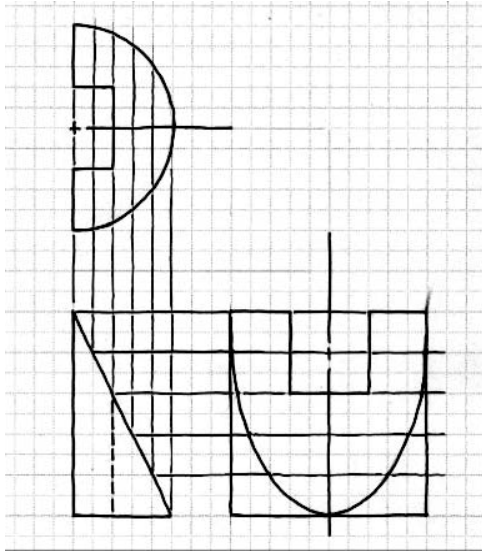

Figure 3-16 Orthographic views

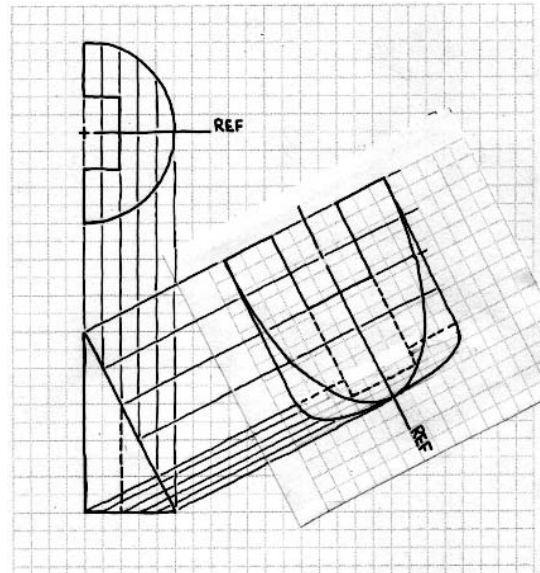

Figure 3-17 Auxiliary view of curved surface

Note that the location of the reference plane in the top view takes advantage of the symmetry of the object.

**NOTES:**

## ORTHOGRAPHIC VIEWS AND MULTI-VIEW SKETCHING

### Problem Set

**3-16** Use an auxiliary view to show the true size of Surface A. Sketch the total object as an auxiliary view.

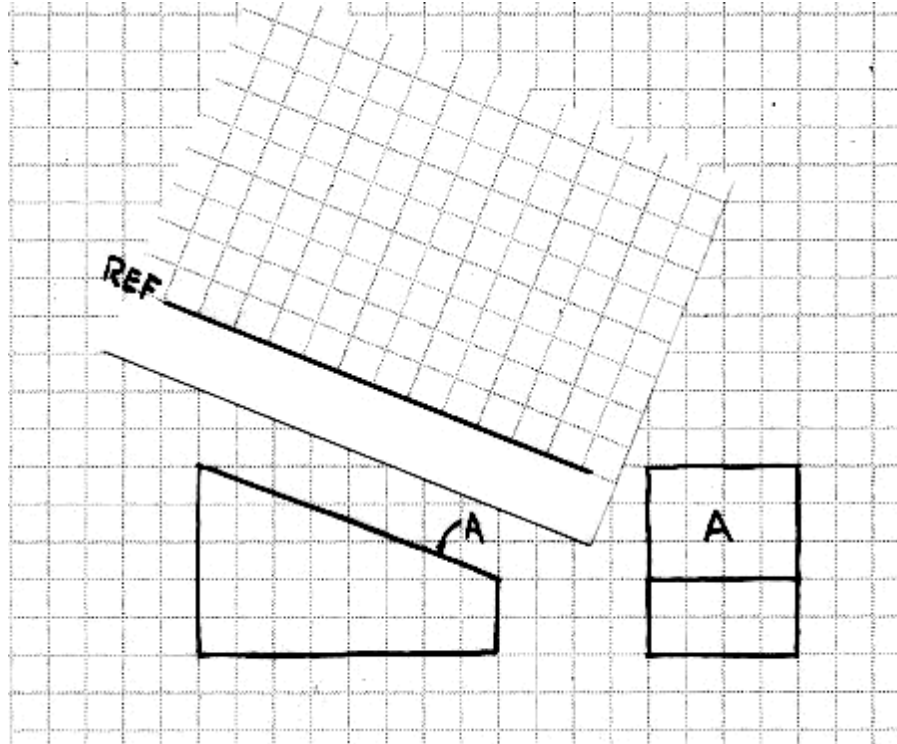

**3-17** Sketch the true size of Surface A only. Use the reference plane given.

