

Voith Turbines in the Power Stations on the American River, California (USA)

VOITH

t 1900e

PCWA 437

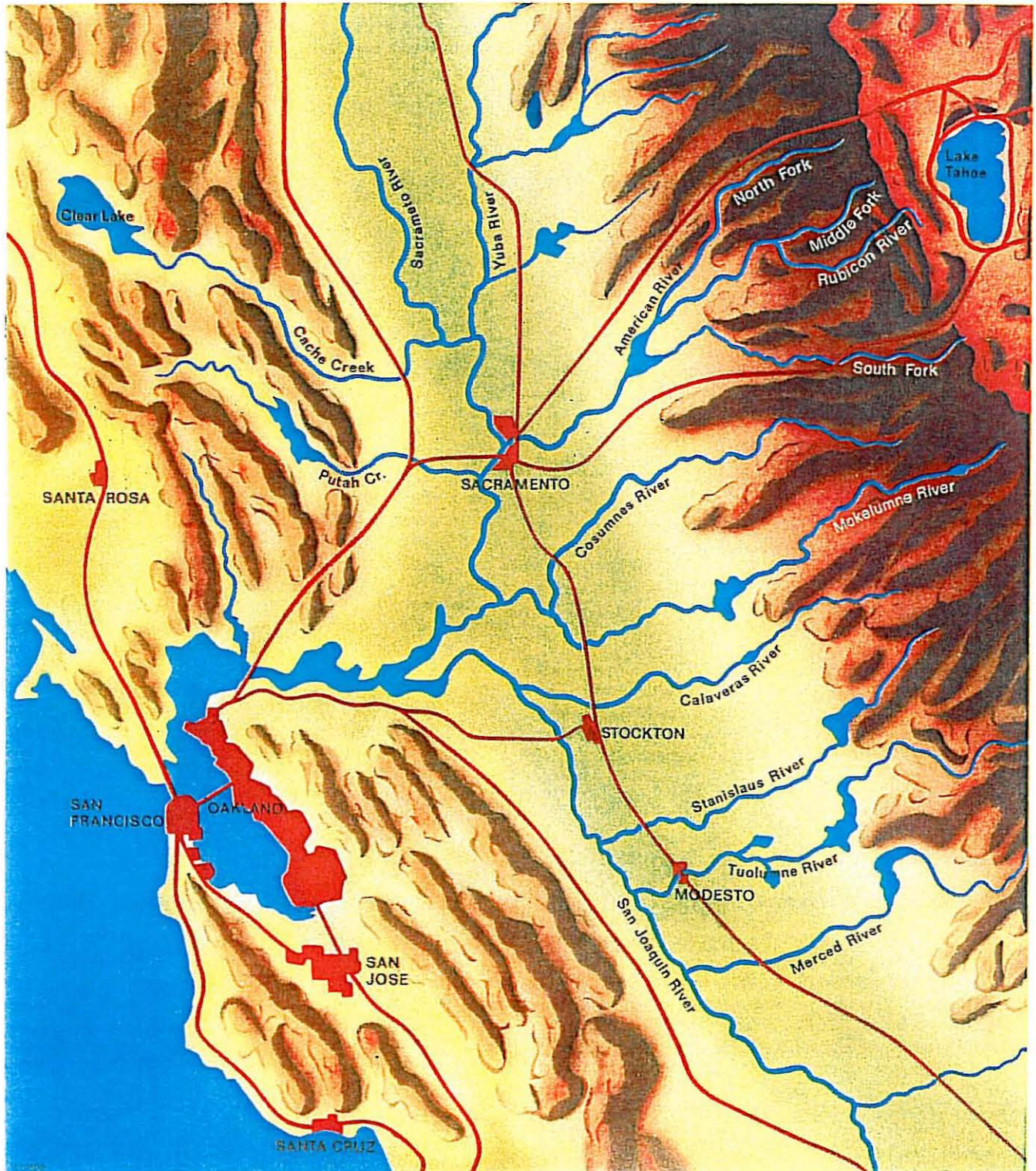

Group of Power Stations on the American River

In 1963, the Voith Company was awarded the contract for the design, construction and supply of the turbines, shut-off valves and governors for the four Hydro-Electric Power Stations of French Meadows, Middle Fork, Ralston and Oxbow. These power stations have been built to provide against flood catastrophes on the American River and the Rubicon River, and to regulate the water flow so that an adequate amount of water would at any time be available for irrigation. The turbines were erected in 1965/1966, and have been in continuous operation since the end of 1966.

Frontispiece: Map of California. To the northeast of the town of Sacramento lie the American River and the Rubicon River, the water power of which is harnessed by the "American River" Hydro-Electric Power Station Group.

Fig. 1 Plan showing the site of the Power Stations of French Meadows, Middle Fork, Ralston and Oxbow.

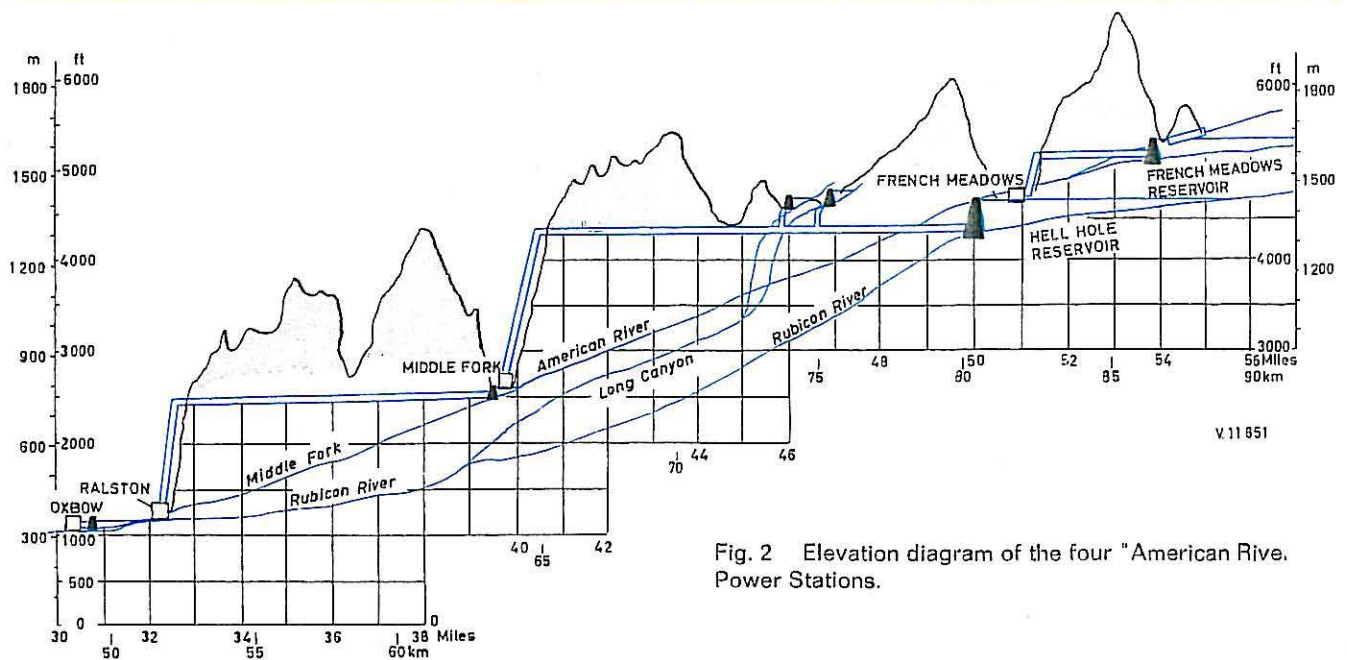
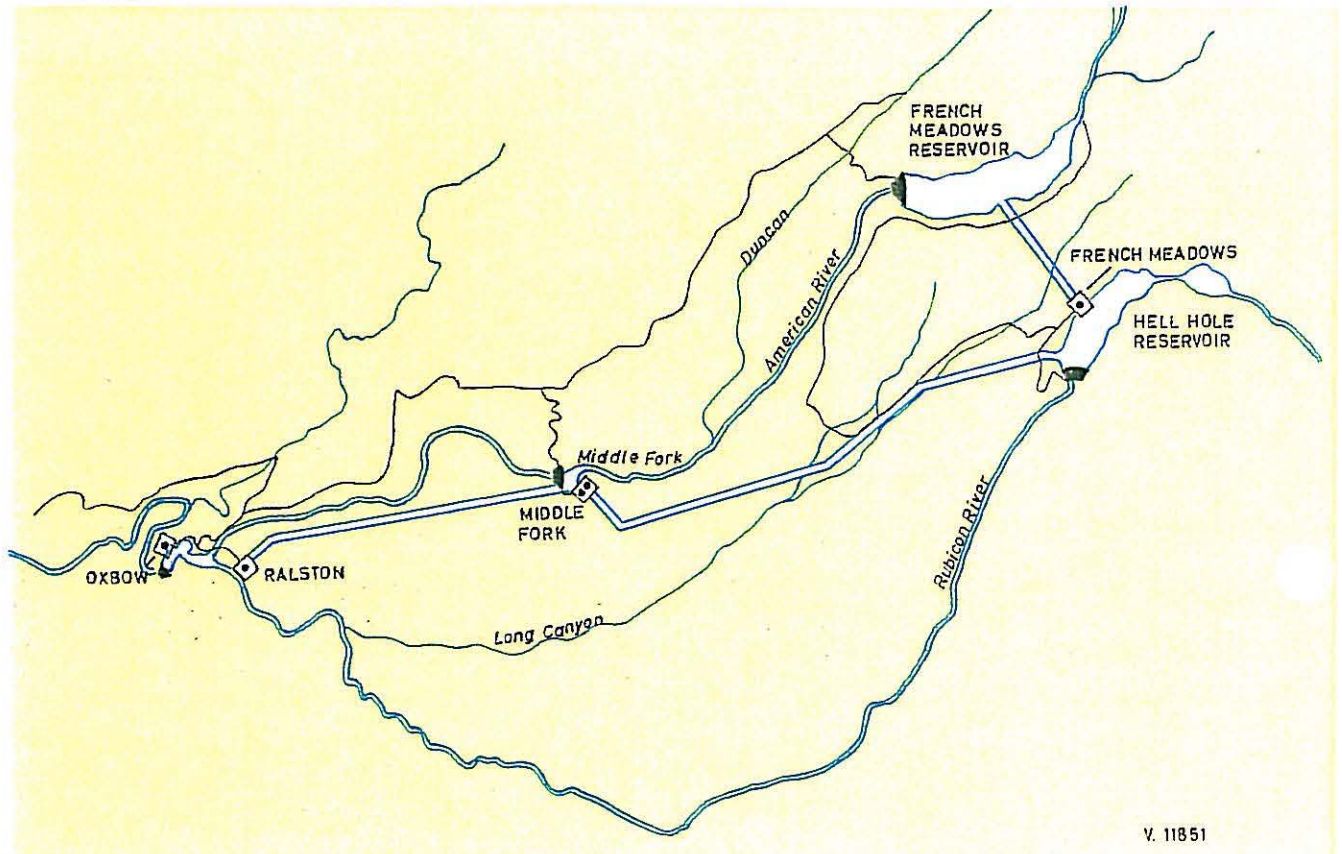

Fig. 2 Elevation diagram of the four "American River" Power Stations.

French Meadows Power Station

This power station utilizes the differential head between the French Meadows reservoir on the American River and the Hell Hole reservoir on the Rubicon River (figs. 1 and 2). Fig. 3 is a cross section through French Meadows Power Station in which a vertical-shaft Francis spiral turbine has been installed, which receives the operating water through a penstock.

Turbine data:

head	579 ft	(182 m)
water discharge	390 cfs	(11.03 m ³ /sec)
speed	450 rpm	
output	17,820 kW	

General design of the turbine

The spiral casing, welded of steel plates, is embedded in concrete, inlet diameter 46⁷/₈" (1,190 mm) (see figs. 4 and 5). The pressure regulator is branched off at a reinforced point of the spiral casing.

The cast-steel turbine head cover is fitted with bores to take the bearing bushings of the wicket-gate trunnions and with a conical collar on which the shaft bearing is attached; all surfaces in contact with the operating water are protected by a stainless-steel liner.

20 cast-steel wicket gates, connected through levers and straps with the welded gate operating-ring which is actuated by a wicket-gate servomotor.

The sealing edges on the wicket gates are of stainless steel. The wicket-gate levers are fitted with breakage bolts. All bearings of the wicket-gate trunnions are lubricated by grease lubricators. The chrome cast-steel runner has 15 vanes and is keyed and bolted to the shaft; inlet diameter of runner 69¹/₈" (1,770 mm). The labyrinth rings on runner crown and runner band are renewable.

The turbine shaft of forged steel has flanges for coupling to the Francis runner and the generator shaft. The self-lubricating guide bearing is arranged direct above the turbine; a separate oil cooler has been provided. A sliding ring seal with two carbon rings prevents leakage past the turbine shaft.

Generator in semi-outdoor arrangement with waterproof cover. In the draft tube, welded of steel plates, two manholes give access for inspection of the runner. As the upper portion of the draft tube can be removed, the runner can be dismantled from underneath and withdrawn sideways. Pipe sections underneath the runner provide aeration of the draft tube. The adjoining draft bend and the horizontal section of the draft tube are of welded construction.

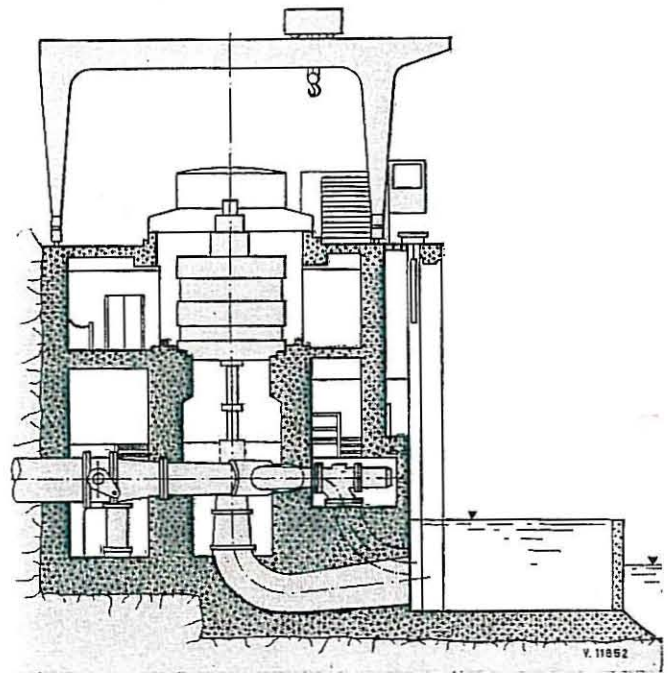

Fig. 3 French Meadows powerhouse with a Francis spiral turbine.

A pressure regulator, connected to a branch of the spiral casing, discharges into the tailrace.

Shut-off valve upstream of the turbine

The butterfly valve installed between penstock and spiral casing has a body welded of cast-steel flanges and steel plating; the valve disk consists of cast steel. Sealing: a moulded rubber seal on the valve disk and additionally a bronze overlay; in the valve body a welded-on strip of stainless steel is provided. Nominal width of butterfly valve 60" (1,500 mm).

The butterfly valve is operated by a double-acting pressure-water servomotor, the cylinder of which is made of stainless steel. The differential piston consists partly of cast steel and partly of cast bronze. The butterfly valve is opened under balanced pressure conditions, but can close against the full water flow.

Turbine regulation

As the pressure tunnel is extremely long and as there is no surge tank, no speed-responsive turbine governing system has been adopted. Instead, an electro-hydraulic positioning element has been fitted by means of which the turbine speed is raised at startup until the net frequency is reached. After synchronization (by means of an electric motor), the turbine is loaded to the value preset on the positioning element. For load rejection, closing of the wicket gates is initiated through a hydro-mechanical safety pendulum. In this case, the pressure regulator connected to the spiral casing prevents an inadmissible pressure rise in the tunnel.

Fig. 4 Section through "French Meadows" Francis spiral turbine.

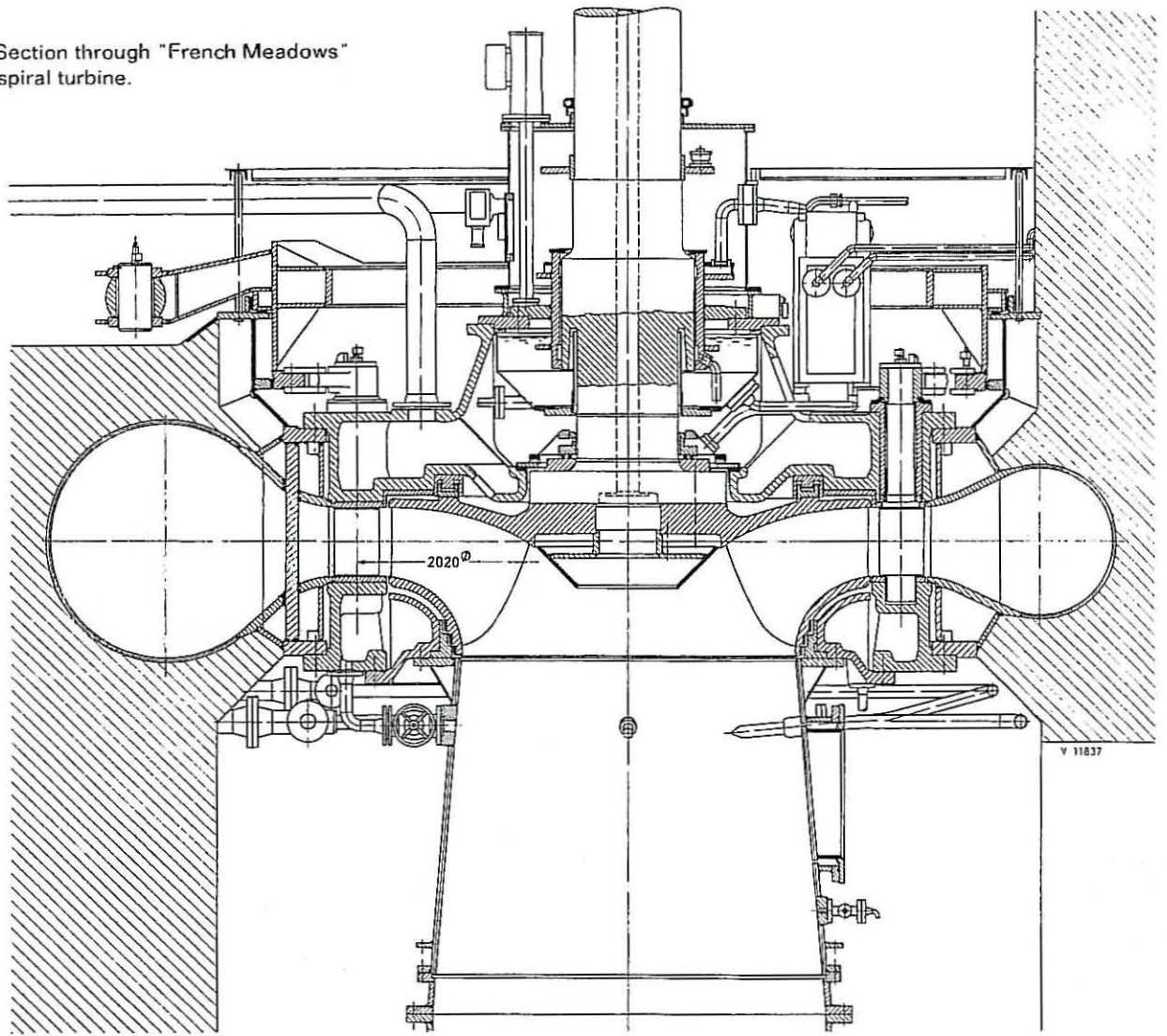

Fig. 5 Plan view of the turbine with the pressure regulator (bottom right).

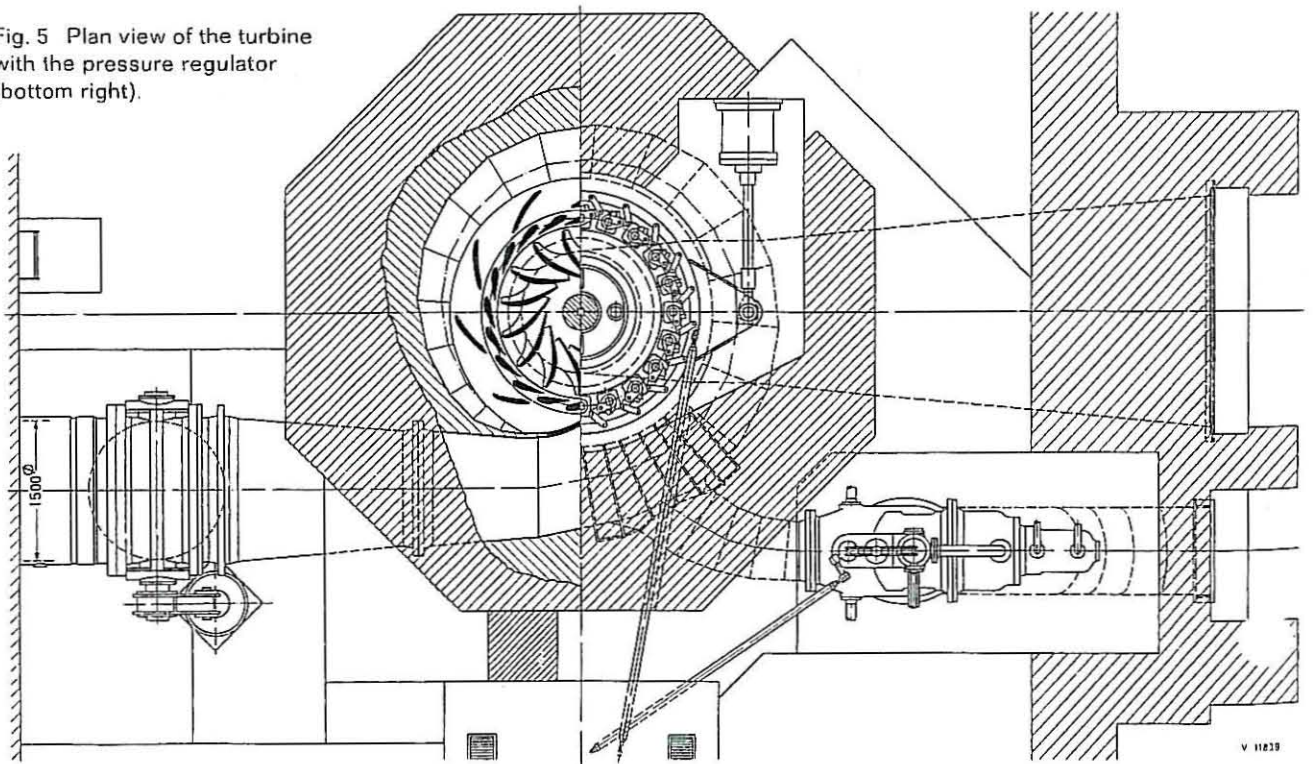

Fig. 6 Installation of the spiral casing in the French Meadows Power Station.

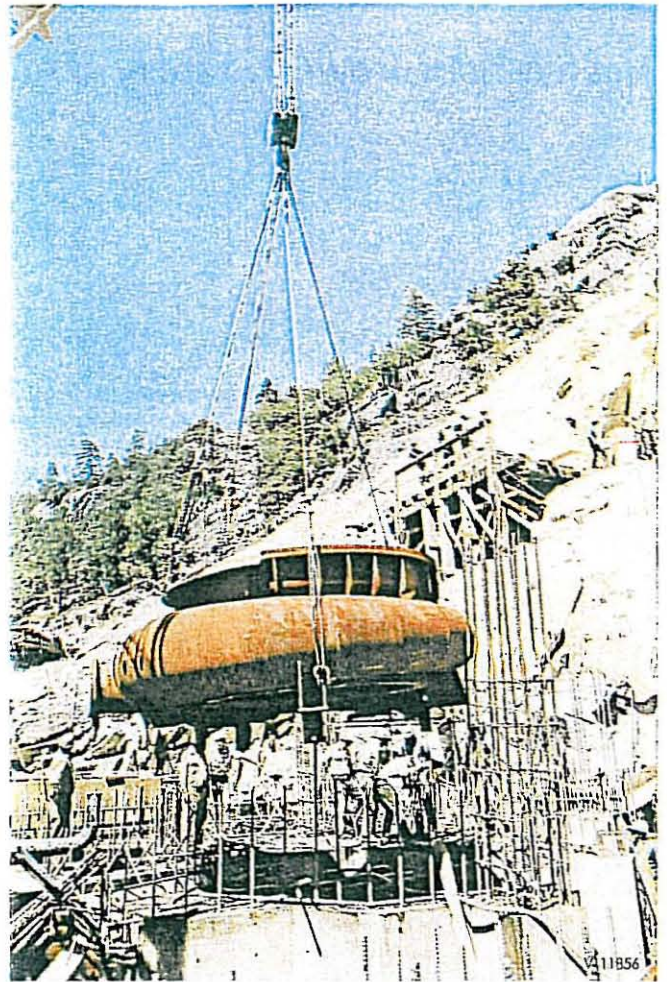
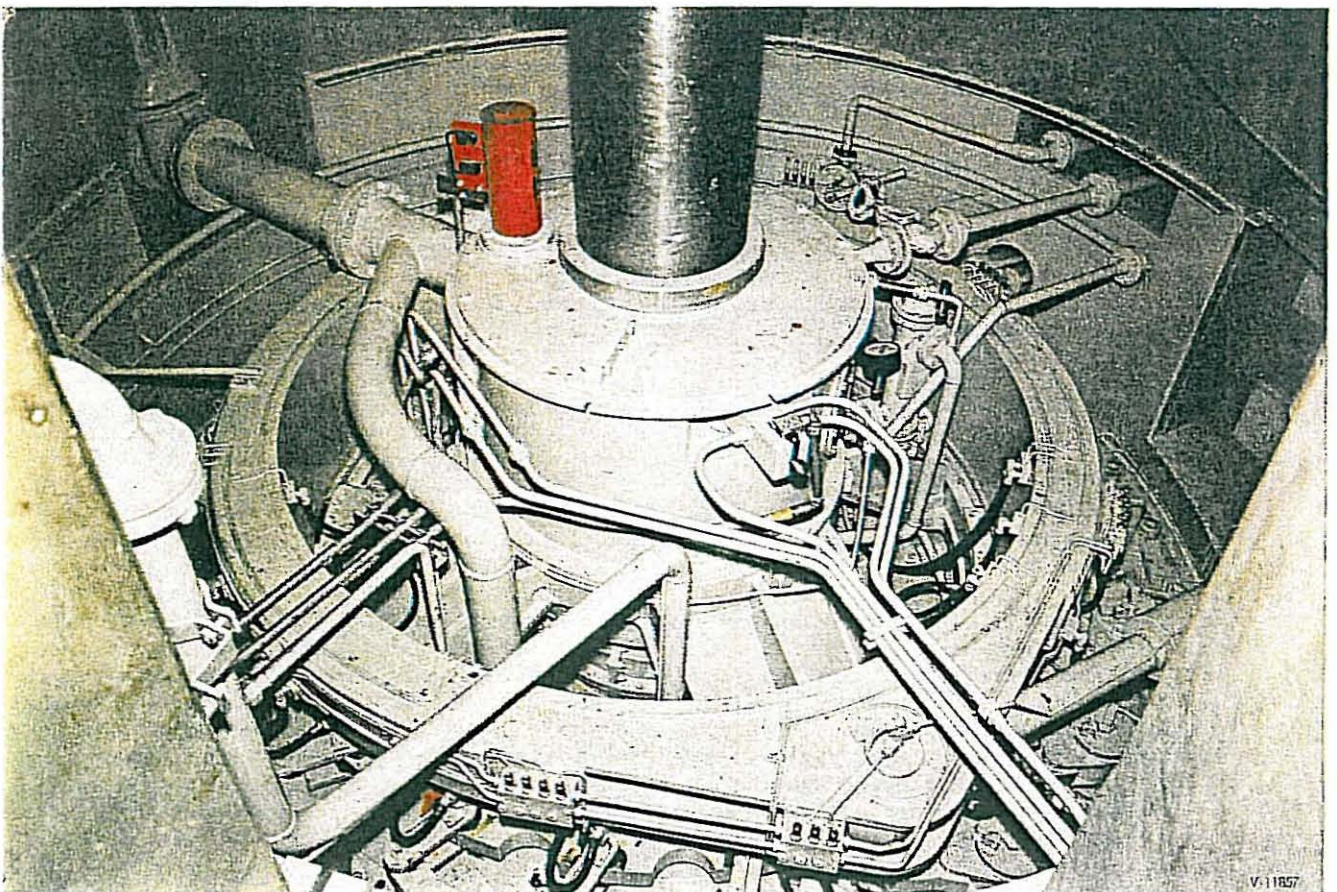

Fig. 7 Looking down the turbine pit of the French Meadows Power Station. In the right foreground, the servomotor linkage driving the gate operating ring.



Middle Fork Power Station

The Middle Fork Power station utilizes the differential head between the Hell Hole reservoir and the small reservoir of the Middle Fork Power Station on the American River. Fig. 8 shows a section through this power station. Two vertical-shaft 6-jet Pelton turbines are connected to a penstock.

Turbine data:

head	1,832 ft	(559 m)
water discharge	438 cfs	(12.48 m ³ /sec)
speed	400 rpm	
output	61,200 kW	

General design of the turbine

The inlet casing, inlet diameter $43\frac{5}{16}$ " (1,100 mm) is embedded in concrete; welded of steel plates, it consists of 6 sections connected through welding-neck flanges; 5 of these sections have branches which lead to the nozzles.

The aeration piping with hydraulically controlled valve is embedded in concrete above the inlet casing.

The Pelton runner of chrome cast-steel is integral cast with 23 buckets.

The turbine shaft, forged of steel, has two flanges for connection with the runner and the generator shaft. In the shaft flange and the runner hub a key is fitted to transmit the torque.

The turbine housing, welded of steel plates, is shaped to provide favourable flow conditions for the water on its passage from the buckets into the tailrace. At the points where the nozzles project into the interior of the housing, a cone construction stiffens the housing. Air pipes terminating underneath the nozzles aerate the turbine housing when the equipment is in operation.

The turbine pit is steel-plate lined. A door in the lateral wall gives access to an inspection grating fitted underneath the runner for convenient inspection.

The self-lubricating guide bearing of the shaft is accommodated in the upper portion of the turbine housing; a separate oil cooler has been installed.

The nozzles have renewable nozzle tips, the needle tips are also renewable. The needles are controlled from the outside. All parts subject to erosion are protected by a hard-chromium layer. Compensating pistons and compensating springs are combined to obtain a closing tendency of the power needles. The needles are controlled by double-acting servomotors. The needle stem is additionally supported midway to provide against vibration. When the nozzles are being closed, the discharging oil is throttled to keep the

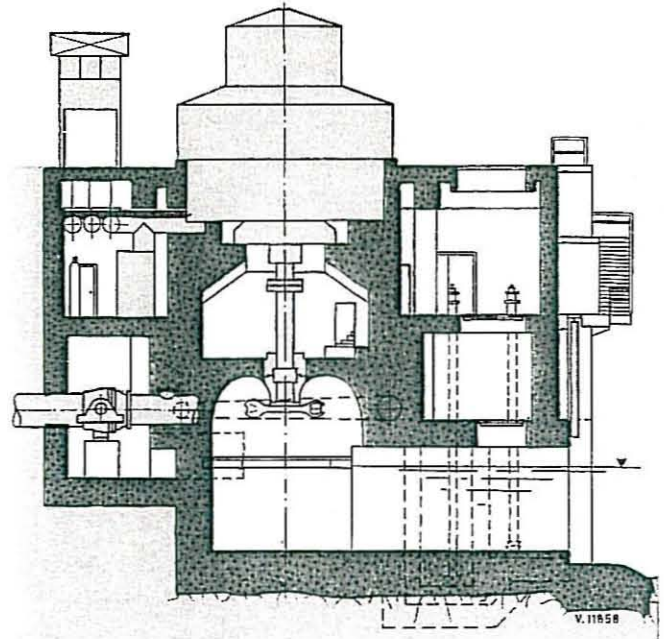

Fig. 8 Section through Middle Fork Power Station with 2 vertical-shaft 6-jet Pelton turbines and generators in semi-outdoor arrangement.

closing speed and thus the pressure rise in the penstock within the prescribed limits.

Each power nozzle has a jet deflector which cuts into the power jet in the event of sudden load rejection. The deflector edge, made of 13% chrome cast-steel, is renewable. All jet deflectors are interconnected through a linkage and are operated by means of a double-acting pressure-oil servomotor. For emergency shutdown, a pressure-water servomotor is additionally available. A grease-lubricating pump automatically supplies the lubricating requirements of the bearings of the deflector shafts and the needle stems.

Shaft seals

A splash-water seal is fitted which consists of several labyrinths in series; furthermore, a standstill seal with a rubber diaphragm is provided which is pressed by compressed air against the shaft flange at the runner end. For subsequent operation of the equipment at a higher water level, a sliding ring seal will be fitted.

Shut-off valve

Upstream of the inlet casing, a spherical valve has been installed with a body which is split at right angles to the axis outside the bearing points (nominal width of the spherical valve $43\frac{5}{16}$ " [1,100 mm], overall length $70\frac{7}{16}$ " [1,789 mm]). Valve body and plug consist of cast steel, the trunnions of the plug are made of forged steel. Pressure water taken from the penstock is used to press the sealing plate against a seal on the downstream portion of the valve body, whereas upstream a maintenance seal allows renewal of the main seal of the spherical valve without the necessity of emptying the penstock. The plug of the spherical valve is operated by a double-acting rack-type pressure-water servomotor attached to the body of the spherical valve. Opening of the spherical valve requires balanced pressure conditions, and for this purpose, a bypass is provided. The spherical valve can, however, close against the full water flow and the full unilateral pressure.

Fig. 9 Cross section through one of the two "Middle Fork" machine sets. Runner pitch circle diameter $94\frac{7}{8}$ " (2,410 mm). Bottom left, compensating and driving piston of one of the power needles; at the right of the runner, one of the jet deflectors;

head
water discharge
speed
output

1,832 ft
438 cfs
400 rpm
61,200 kW
(559 m)
(12.48 m³/sec)

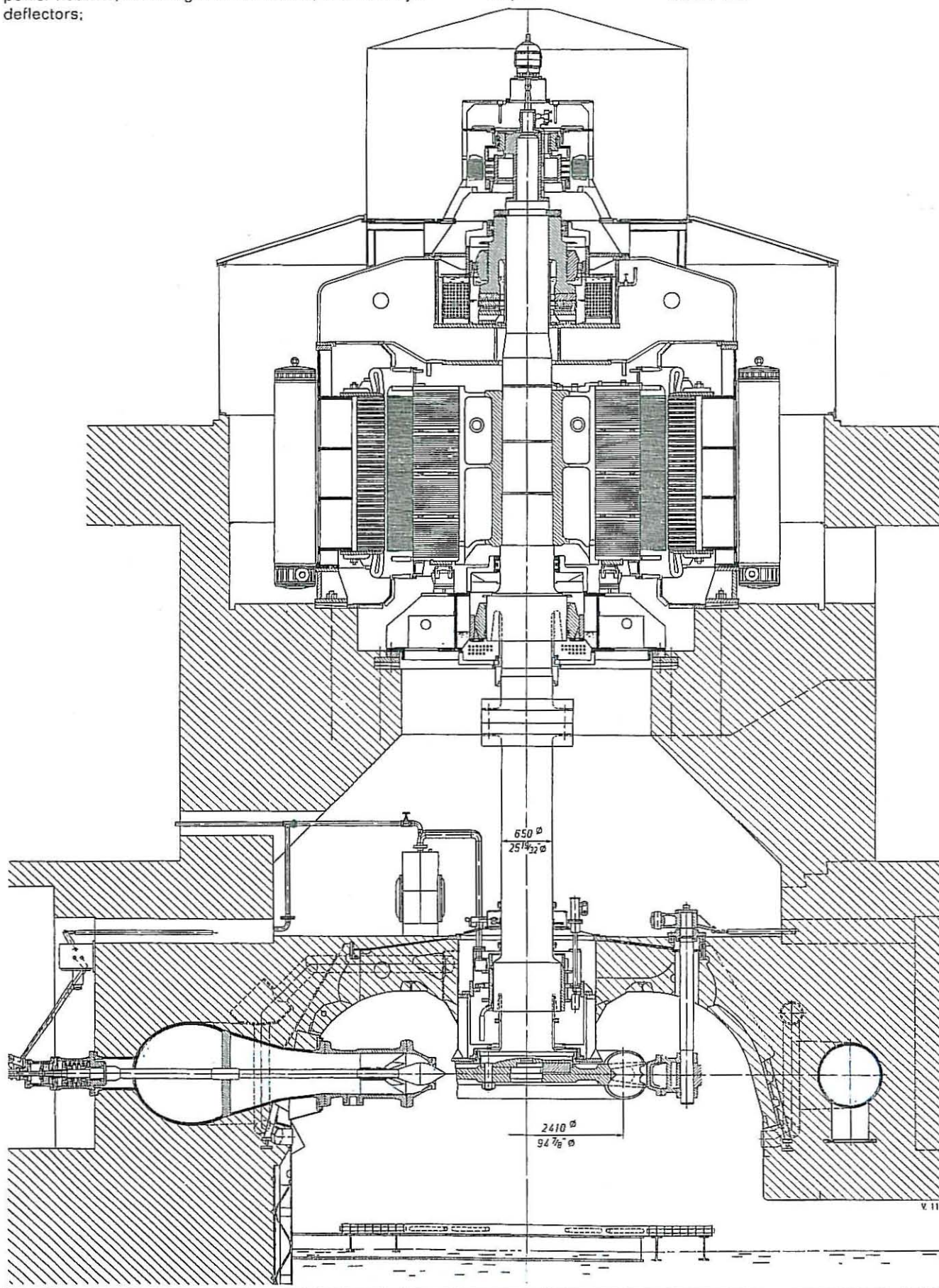

v. 11

Fig. 10 Horizontal section through one of the two 6-jet Pelton turbines installed in the Middle Fork Power Station. A spherical valve with rack-type servomotor drive is installed between penstock and turbine.

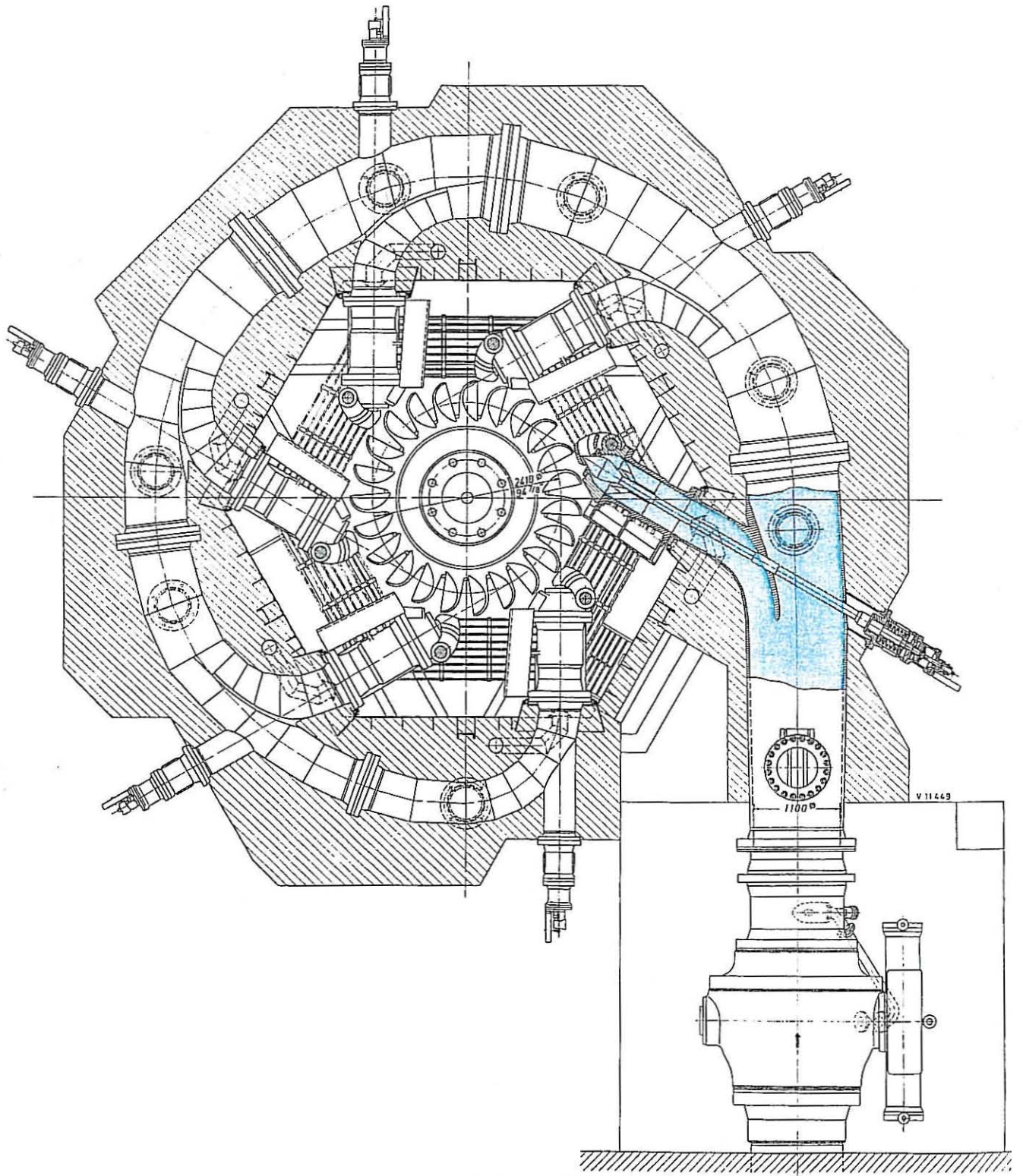

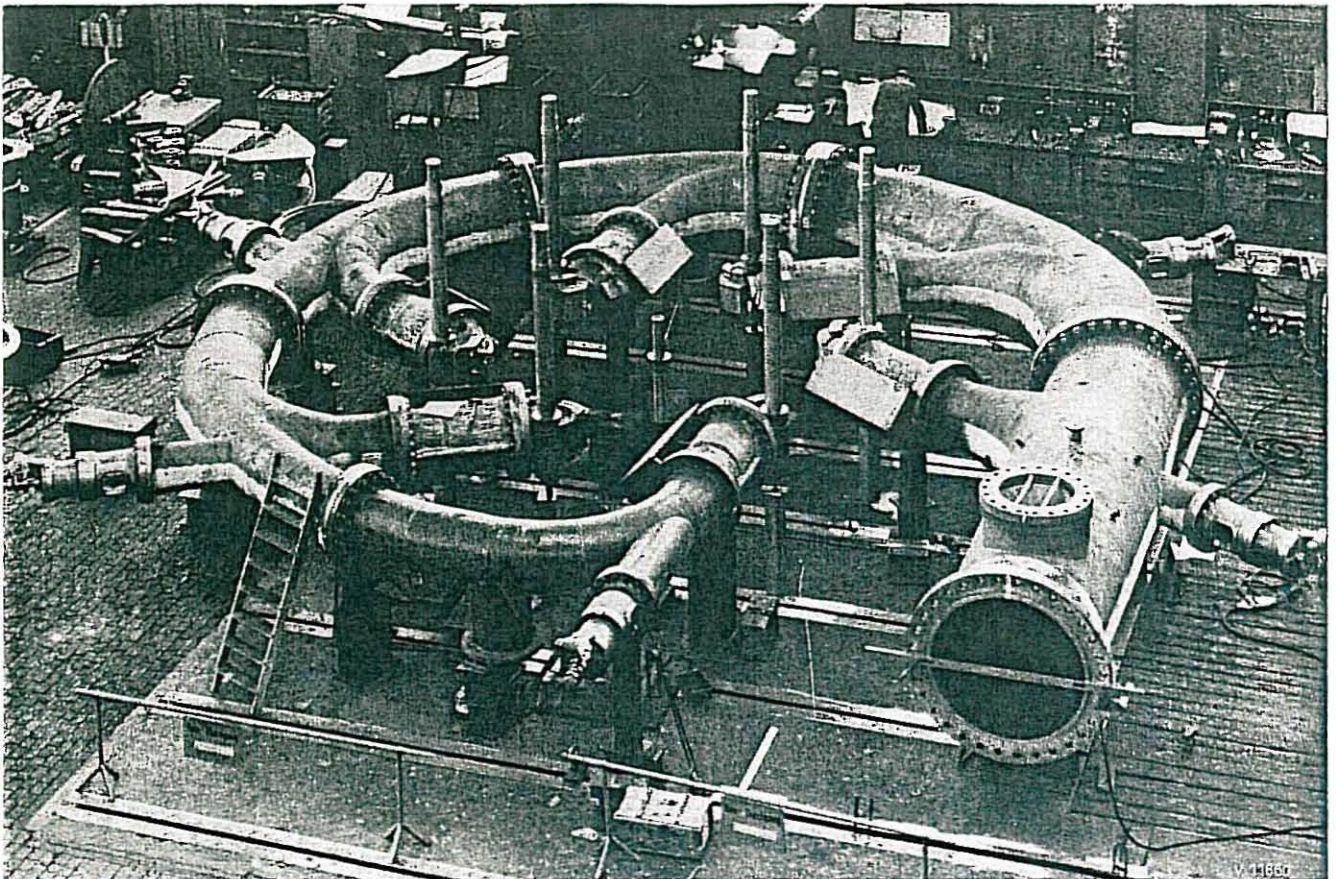

Fig. 11 "Middle Fork" inlet-casing assembly in our large turbine hall. The nozzles with the needle drives as well as the jet deflectors have already been mounted.

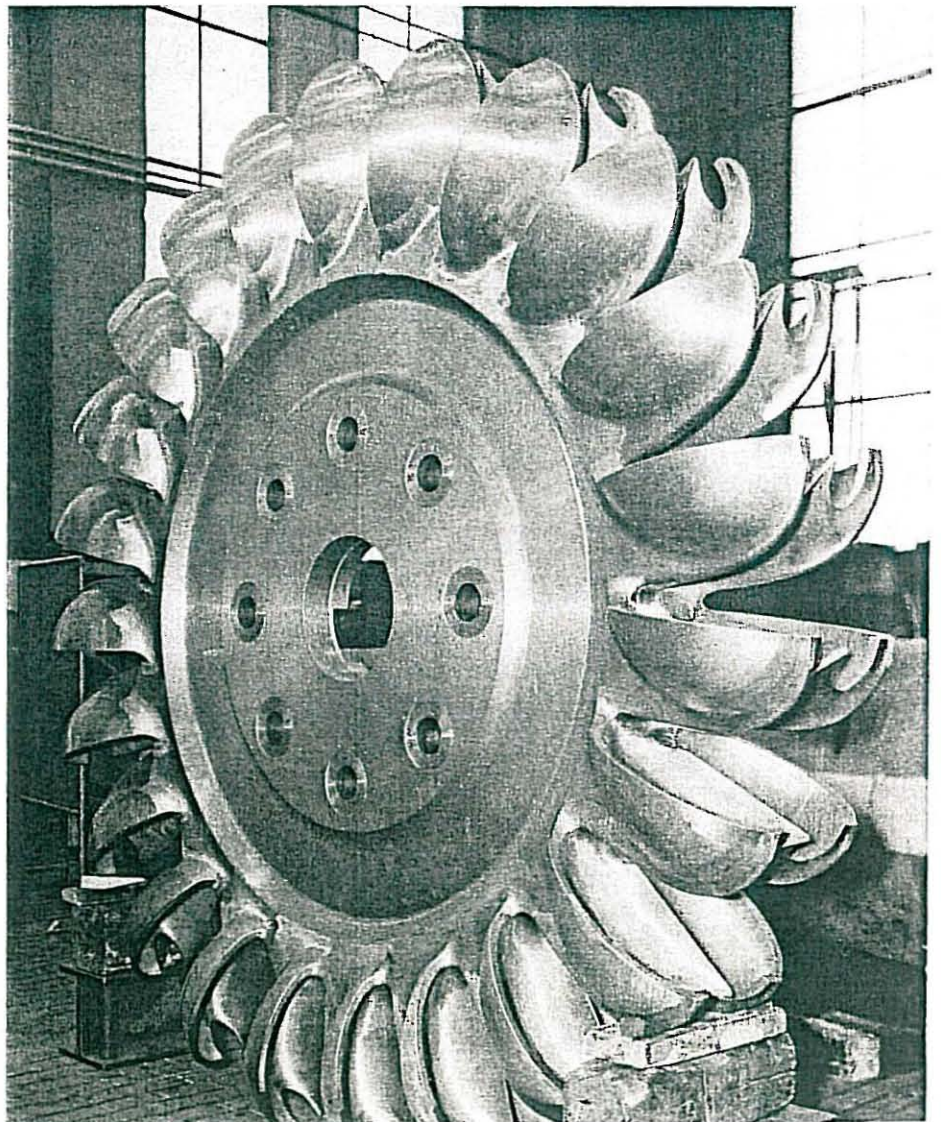

Fig. 12 One of the "Middle Fork" Pelton runners with finished wheel disk and buckets.

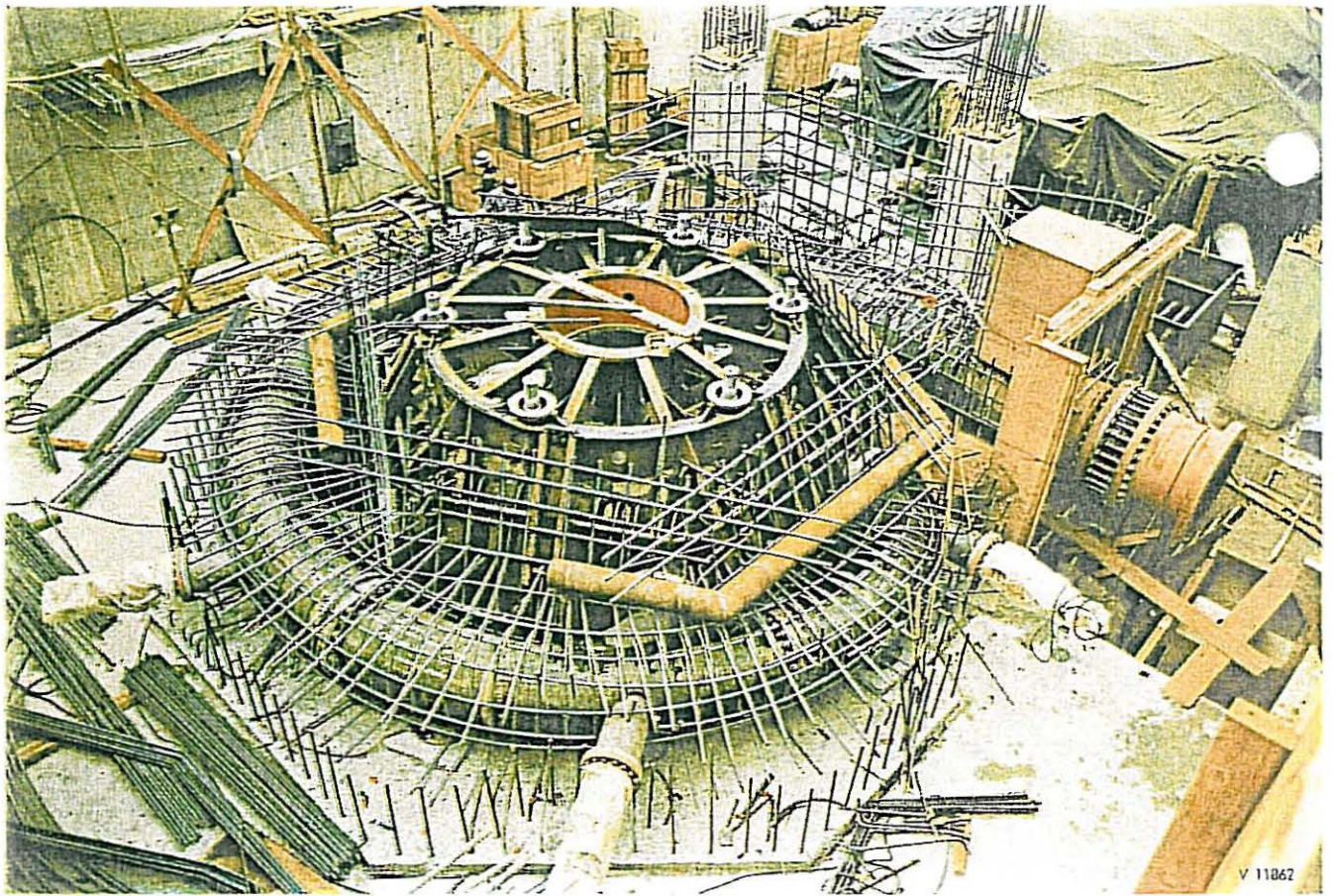
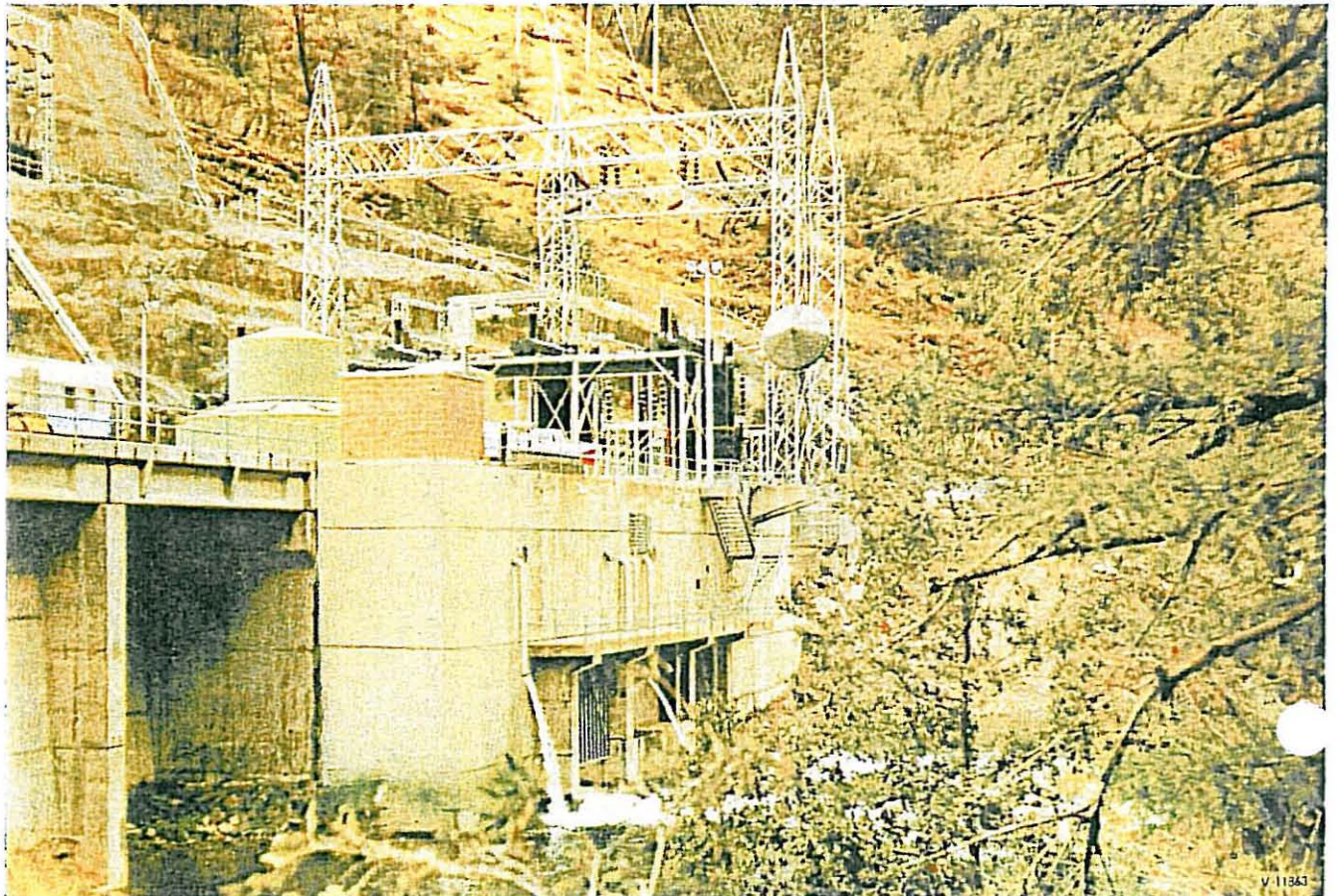

Fig. 13 Inlet casing of one of the two "Middle Fork" turbines prepared for concreting in. Spherical valve and penstock follow at the right. On top of the inlet casing, the aeration piping for the turbine pit is visible.

Fig. 14 Middle Fork Power Station. At the left, one of the semi-outdoor generators.



Ralston Power Station

The Ralston Power Station utilizes the differential head between the Middle Fork regulating reservoir and the Oxbow storage reservoir downstream of the Ralston Power Station. This power station houses a vertical-shaft 6-jet Pelton turbine (fig. 15).

Turbine data:

head	1,250 ft	(382 m)
water discharge	834 cfs	(23.65 m ³ /s)
speed	240 rpm	
output	88,000 kW	

General design of the turbine

Inlet casing embedded in concrete, inlet diameter 61" (1,550 mm), welded of steel plates and consisting of 6 sections inter-connected through welding neck flanges. Five of these sections have branches leading to the power nozzles. Above the inlet casing, the aeration piping with hydraulically control valve is embedded in concrete.

Chrome cast-steel Pelton runner with 23 integral cast buckets.

The turbine shaft, forged of steel, has two flanges for connection to the runner and the generator shaft. In the shaft flange and the runner hub a key is fitted to transmit the torque.

The turbine housing, welded of steel plates, is shaped to ensure optimum flow conditions for the water on its way from the buckets into the tailrace. A cone construction stiffens the housing at the points where the nozzles project into the interior of the housing. Underneath the nozzles, air pipes terminate which provide aeration of the turbine housing when the equipment is in operation.

The turbine pit is lined with steel plates. A door in the lateral wall gives access to an inspection grating fitted underneath the runner for convenient inspection.

In the upper portion of the turbine housing, the self-lubricating guide bearing of the shaft is accommodated. A separate oil cooler is provided.

The power nozzles have renewable nozzle tips, the needle tips are also renewable. The needles are controlled from the outside. All parts subject to erosion are protected by a hard-chromium layer. Compensating pistons and compensating springs are combined to give the needles a closing tendency. The needles are operated by double-acting servomotors. The needle stem is additionally supported midway to provide against vibration. When the nozzles are closing, the discharging oil is throttled to keep the closing speed, and thus the pressure rise in the penstock, within permissible limits.

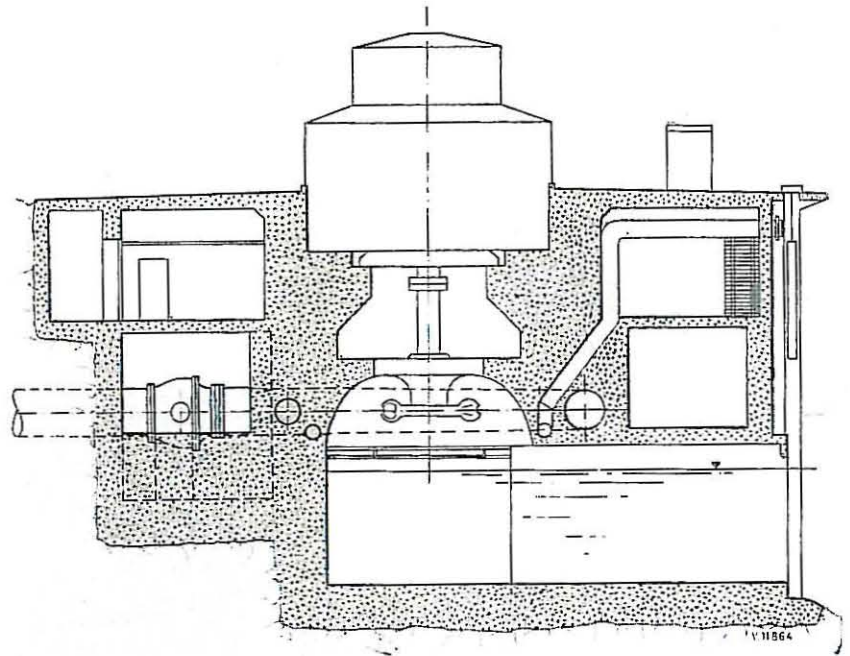

Fig. 15 Ralston Power Station with a vertical-shaft 6-jet Pelton turbine and a generator in semi-outdoor arrangement.

Each nozzle is fitted with a jet deflector which cuts into the power jet in the event of sudden load rejection. The deflector edge consisting of 13% chrome cast-steel is renewable. All jet deflectors are interconnected through a linkage and are operated by means of a double-acting pressure-oil servomotor. For emergency shutdown, a pressure-water servomotor is additionally available. The bearings of the deflector shafts and the needle stems are automatically lubricated by a grease-lubricating pump.

Shaft seals

A splash-water seal is provided which consists of several labyrinths in series; furthermore, a standstill seal with a rubber diaphragm is pressed by compressed air against the shaft flange at the runner end. For subsequent operation with a higher tailwater level, a sliding ring seal will be fitted.

Shut-off valve

Upstream of the inlet casing, a spherical valve is installed with a body which is split at right angles to the axis outside the bearing points (nominal width of the spherical valve 61" [1,550 mm], overall length 94⁵⁹/₆₄" [2,411 mm]). Valve body and plug consist of cast steel, the trunnions of the plug of forged steel. Pressure water taken from the penstock presses the sealing plate against a seal on the downstream portion of the valve body. A maintenance seal fitted upstream allows renewal of the main seal of the spherical valve without the necessity of emptying the penstock. The valve plug is operated by a double-acting rack-type pressure-water servomotor attached to the body of the spherical valve.

For opening of the spherical valve, the pressure must be balanced upstream and downstream of the valve. For this purpose a bypass is provided. The spherical valve can close against the full water flow and the full unilateral pressure.

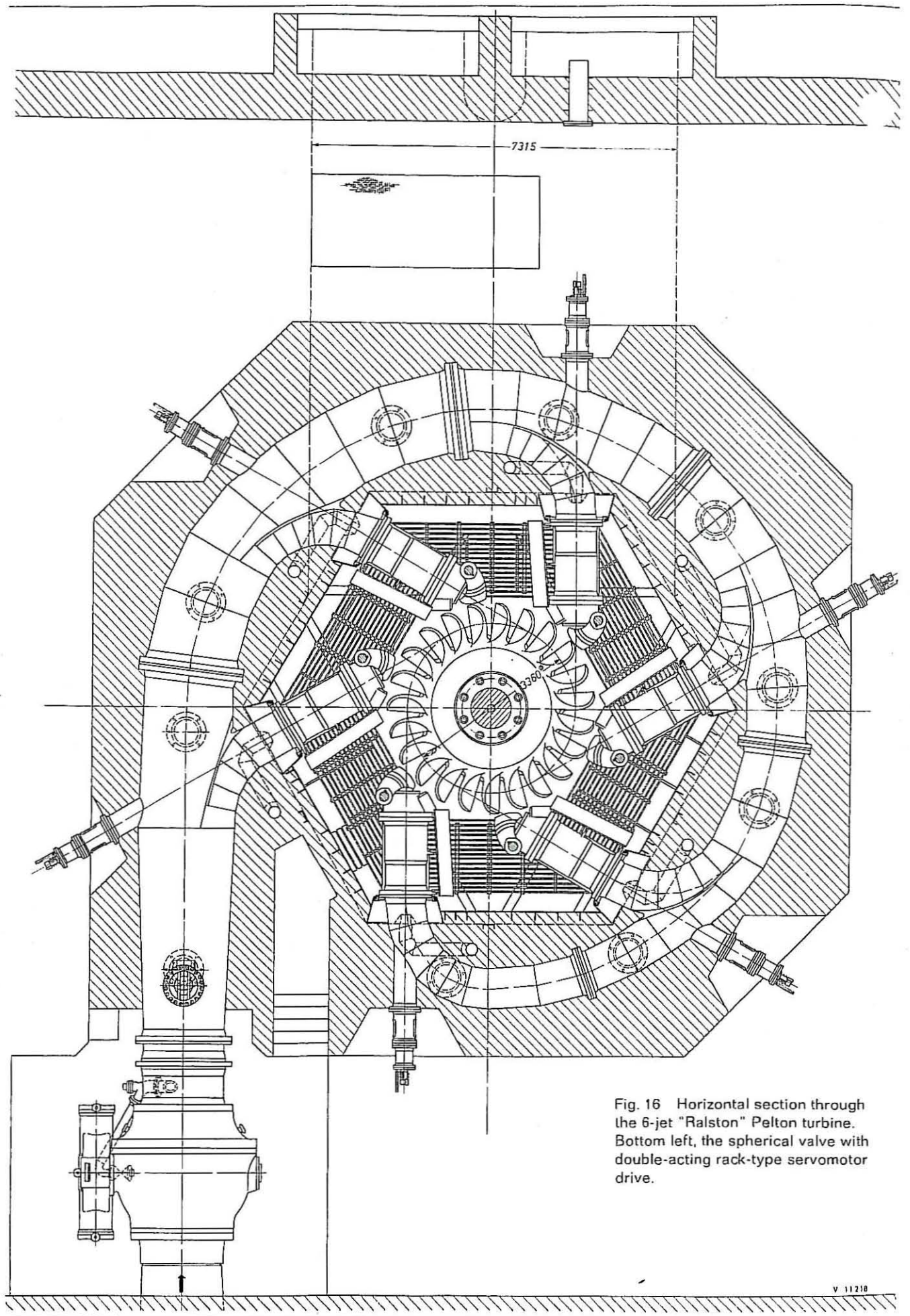
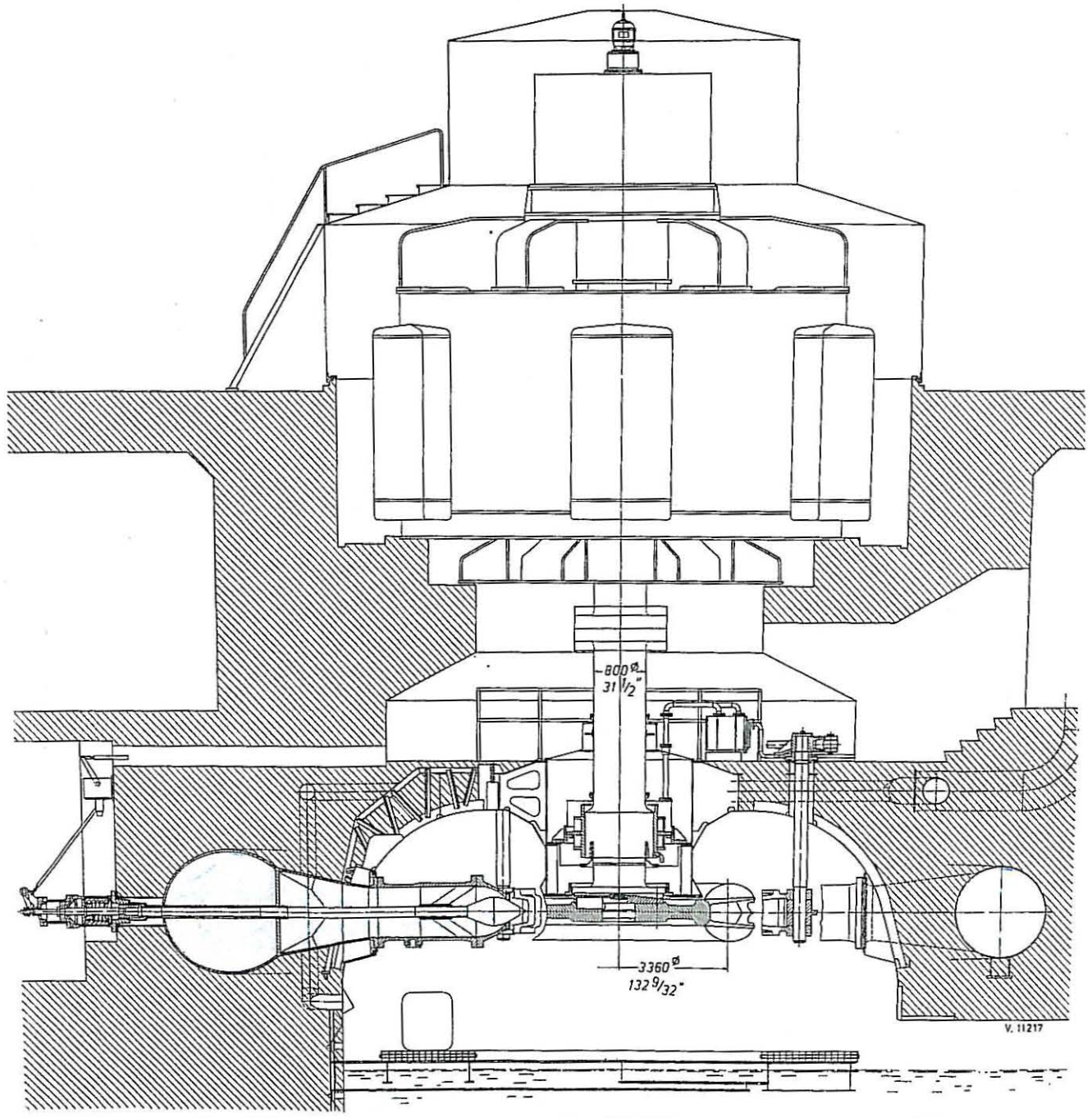

Fig. 16 Horizontal section through the 6-jet "Ralston" Pelton turbine. Bottom left, the spherical valve with double-acting rack-type servomotor drive.

V 11218

Fig. 17 Vertical section through the 6-jet "Ralston" Pelton turbine, runner pitch circle diameter $132\frac{9}{32}$ " (3,360 mm). At the left, the drive of one of the 6 needles is visible; at the right of the runner, one of the 6 jet deflectors.

head	1,250 ft	(382 m)
water discharge	834 cfs	(23.65 m ³ /sec)
speed	240 rpm	
output	88,000 kW	



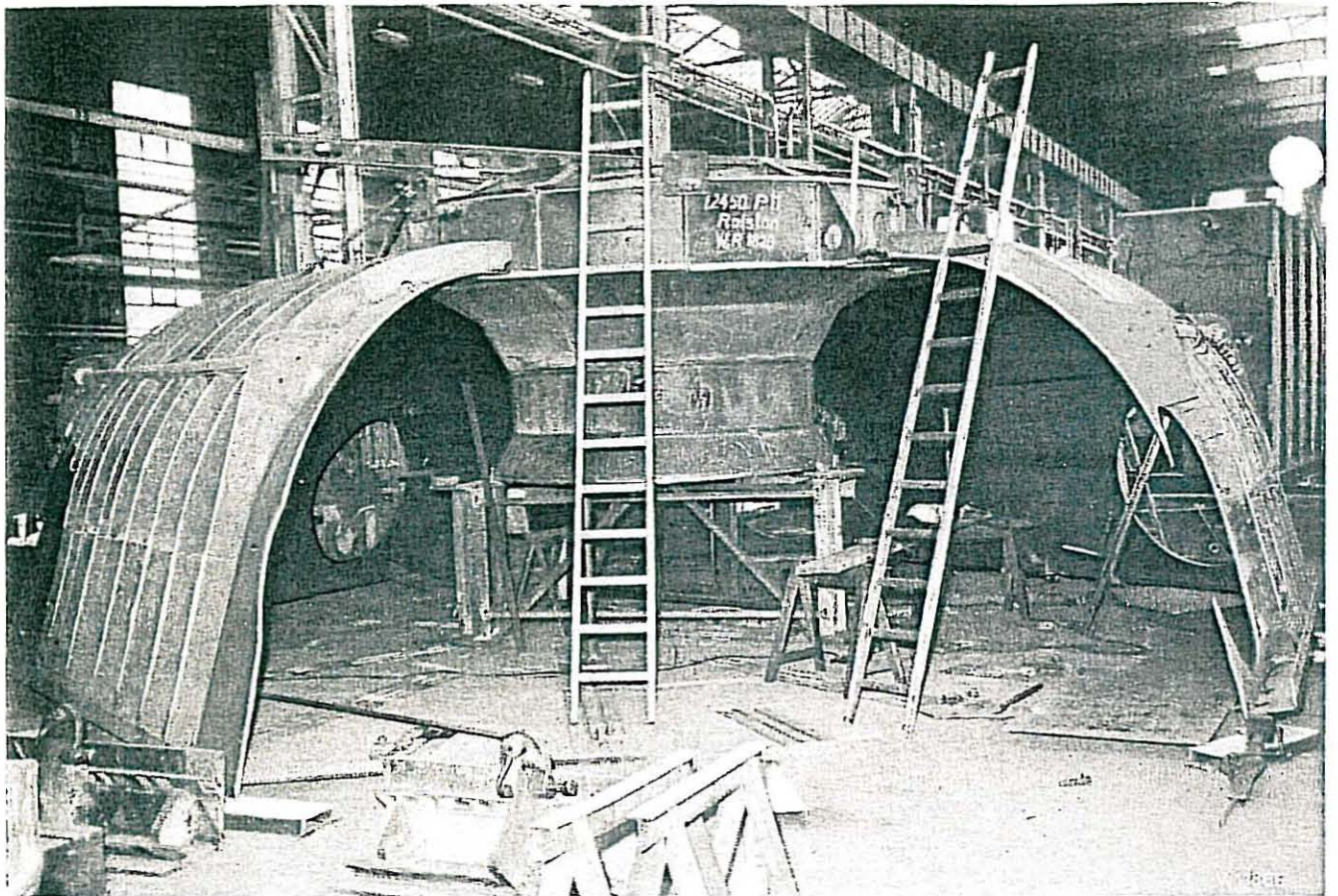

Fig. 18 Housing of the vertical-shaft "Ralston" Pelton turbine being assembled in our steel construction shop.

Fig. 19 Assembly of the "Ralston" inlet casing in our large turbine hall. The nozzles and needle drives have already been installed, while the jet deflectors have not yet been fitted.

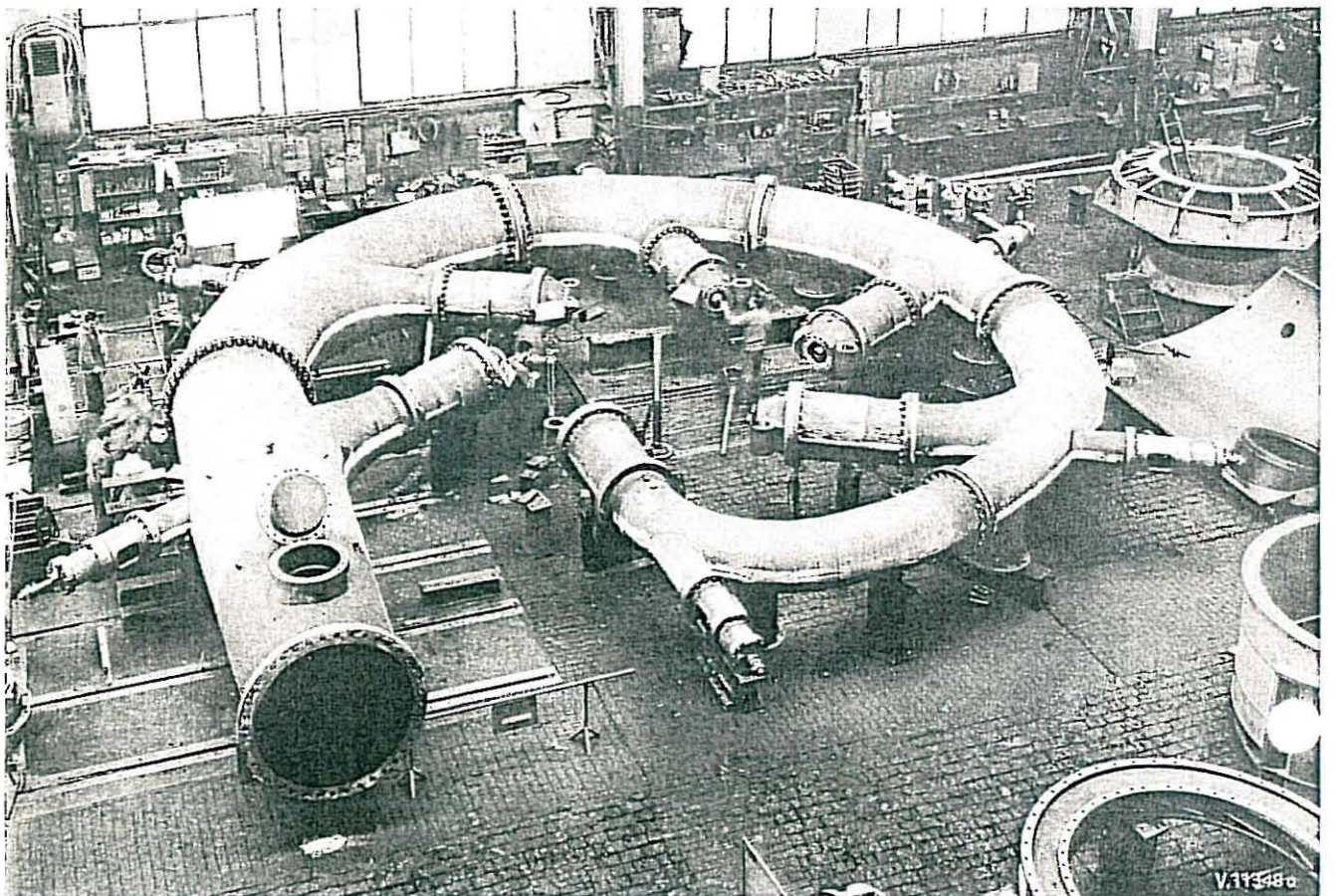
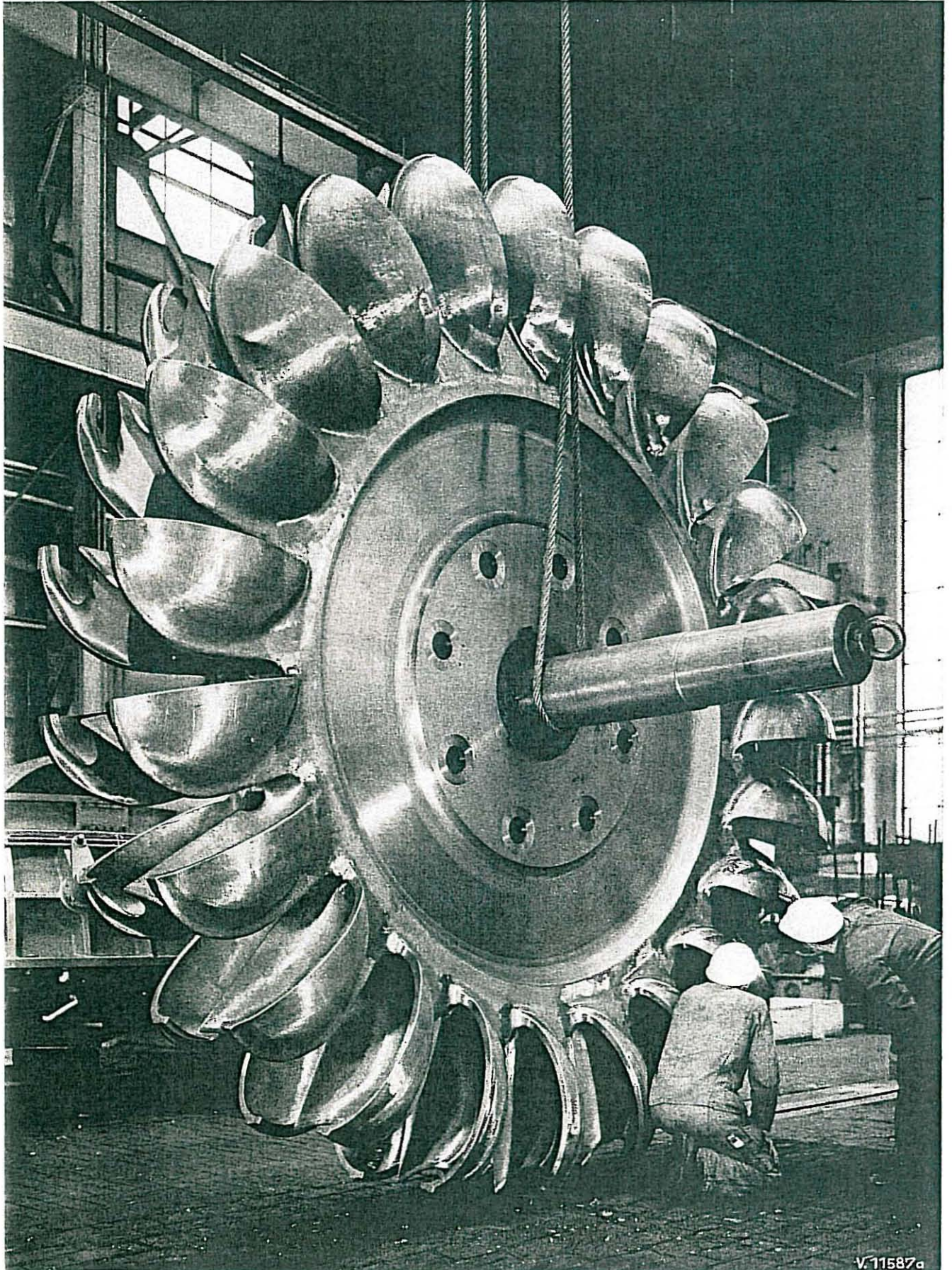

Fig. 20 "Ralston" Pelton runner, runner pitch circle diameter $132\frac{9}{32}$ " (3,360 mm), maximum runner diameter $164\frac{49}{64}$ " (4,185 mm). Weight of the runner — which is integral cast of 13% chrome cast-steel — 22 tons.



V.11587a

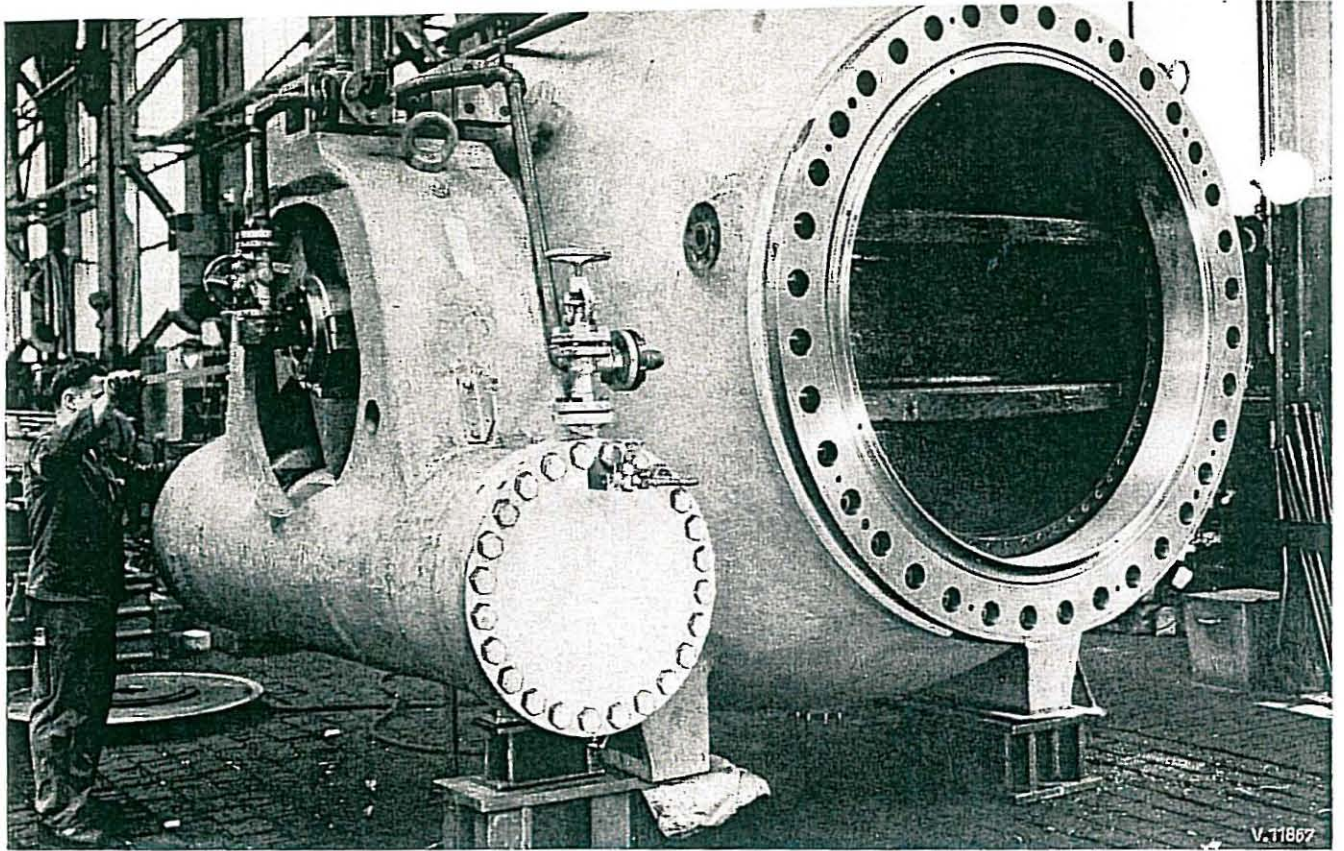
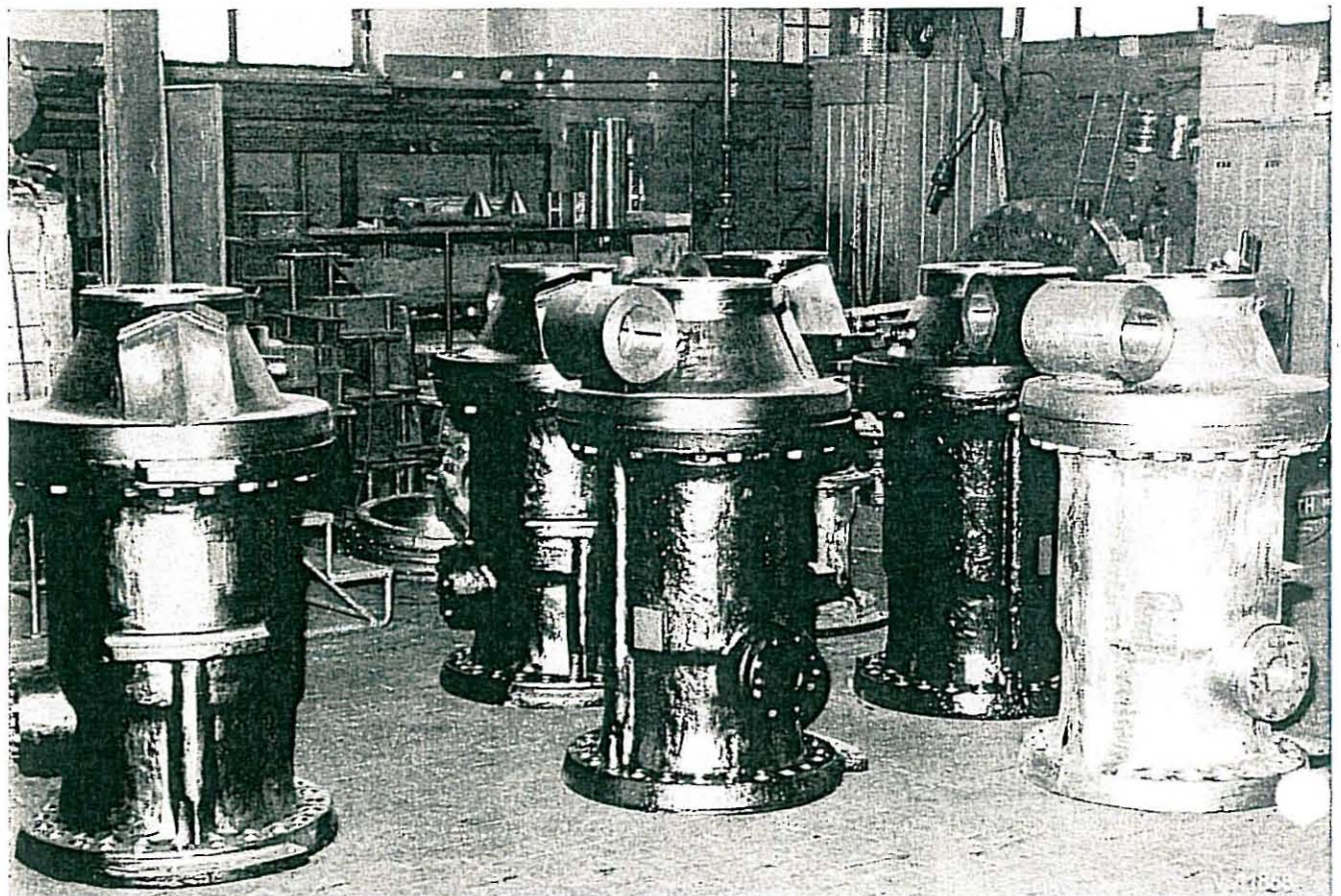

Fig. 21 Spherical valve as shut-off valve upstream of the "Ralston" turbine. At the left, the double-acting rack-type servomotor, which in either direction is operated by pressure water.

Fig. 22 The 6 nozzle bodies with the attached nozzle tips for the "Ralston" turbine.



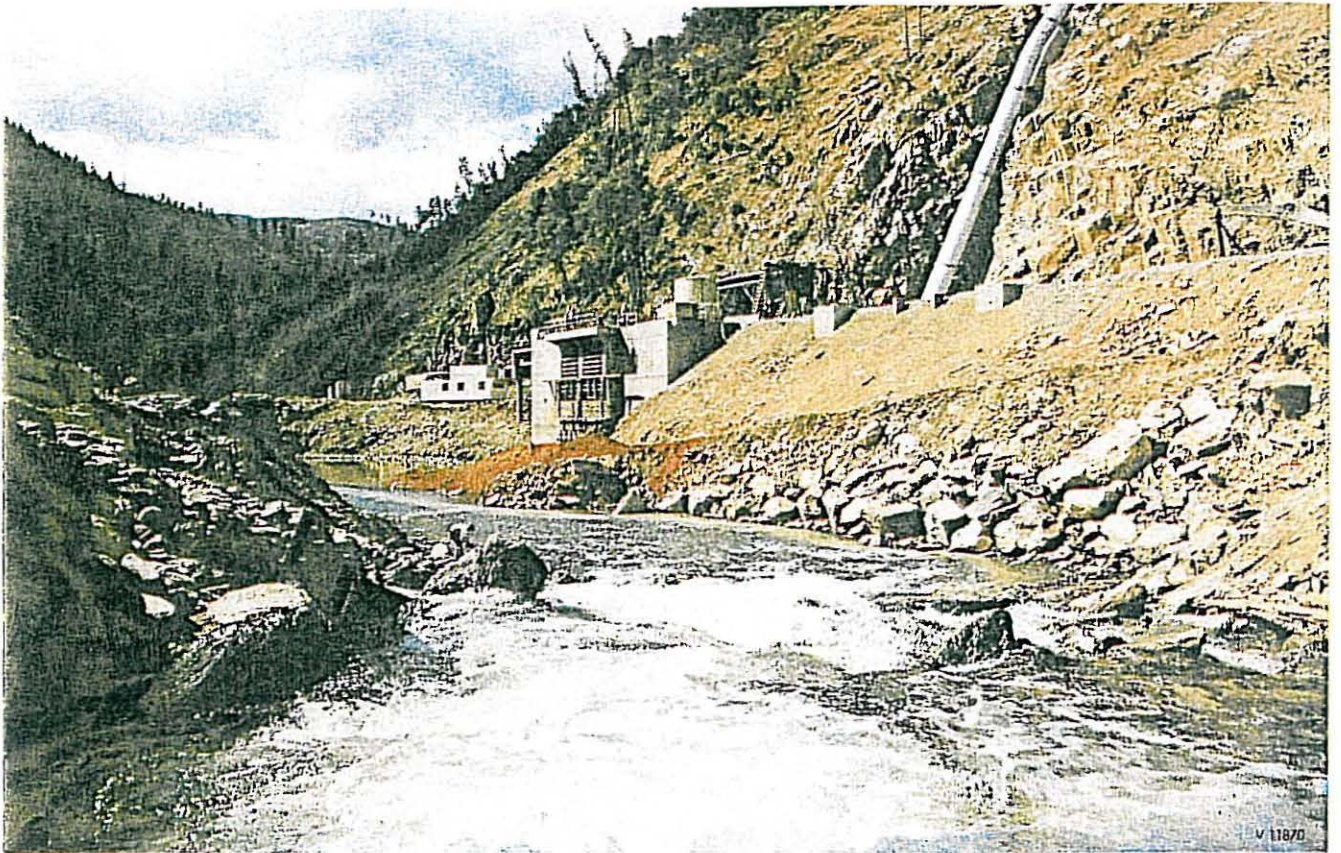
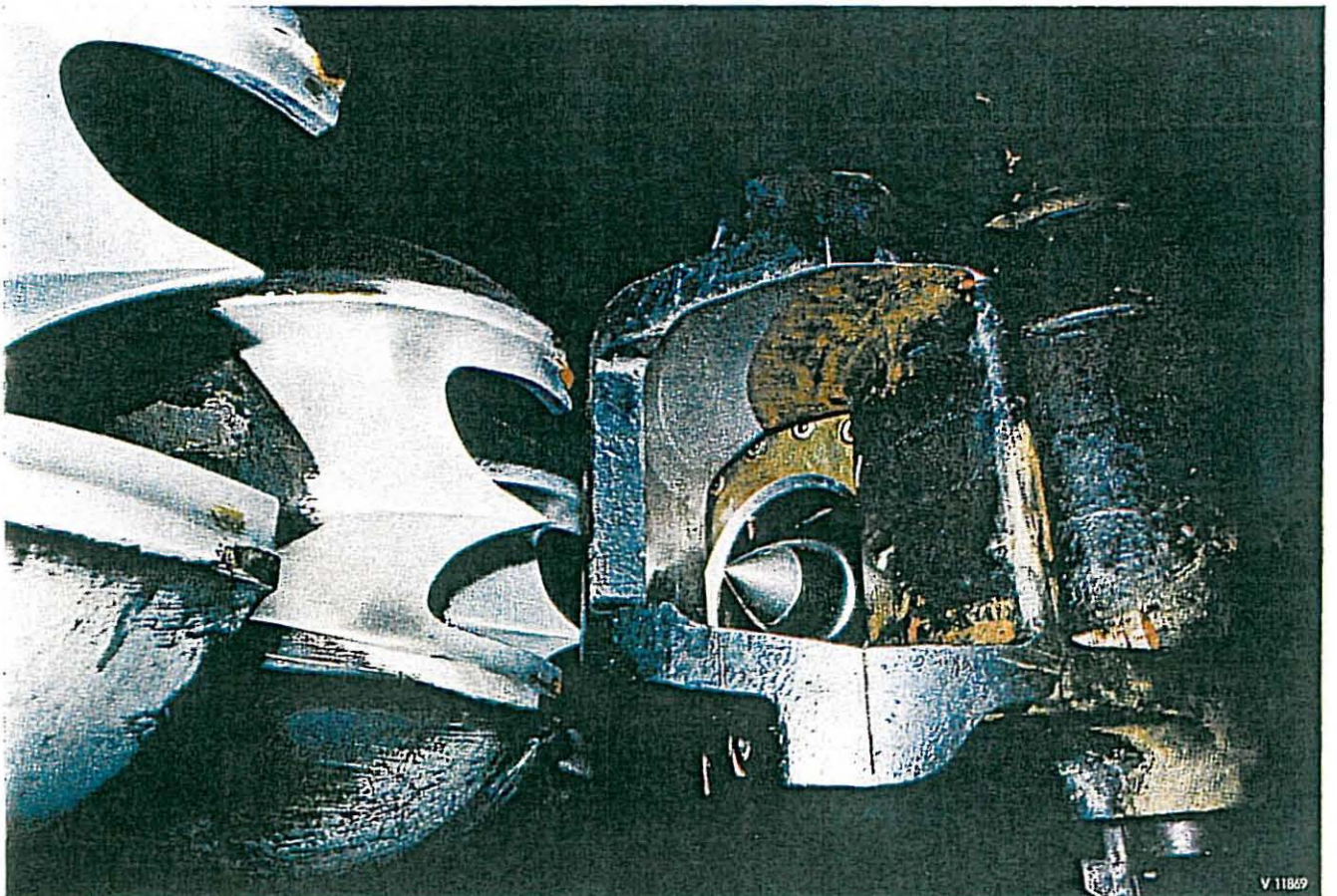

Fig. 23 Looking through the jet deflector in the direction of the nozzle with the needle in the assembled "Ralston" Pelton turbine.

Fig. 24 Ralston Power Station on the Rubicon River.

(N. B.: captions mixed up)



Oxbow Power Station

This power station utilizes the differential head between the storage reservoir and the "Middle Fork" reservoir on the American River downstream of the power station. In the Oxbow Power Station, a vertical-shaft Francis spiral turbine has been installed which receives the operating water through a short penstock.

Turbine data

head	87 ft	(26.5 m)
water discharge	995 cfs	(28.2 m ³ /sec)
speed	200 rpm	
output	6,550 kW	

General design of the turbine

The spiral casing, inlet diameter 108" (2,744 mm), is welded of steel plates and is embedded in concrete. Turbine head cover and curb ring consist of cast steel; they are lined with stainless steel in the wicket-gate zone.

20 cast-steel wicket-gates; their sealing edges are made of stainless steel. The wicket-gate stems are supported in bronze bushings. The wicket-gate levers are split and connected through breakage bolts.

The 13% cast-steel Francis runner is flanged onto the turbine shaft and coupled by fitted bolts. The mean inlet diameter is 78" (1,980 mm). Renewable chrome-steel wearing rings are fitted on runner crown and runner band.

The shaft seal is of the sliding-ring type with carbon rings.

The turbine shaft is supported in a self-lubricating bearing and has flanges for connection to the runner and the generator shaft. The bearing oil is cooled by an oil cooler. Various measuring instruments read pressure and temperature of the bearing oil.

The bend of the draft tube consists of a steel-plate liner, while the horizontal portion is embedded in concrete. Underneath the runner, a manhole allows inspection of the runner.

The draft tube is aerated by pipes run in the interior of the draft tube. The aeration pipes are opened and closed by valves operated by pressure oil. A pipe branches off at the spiral casing and leads to a dispersion valve, which is used as pressure regulator and bypass outlet.

The dispersion valve is accommodated in a stilling chamber and discharges above one of the draft tube halves of the Francis turbine. To ensure that

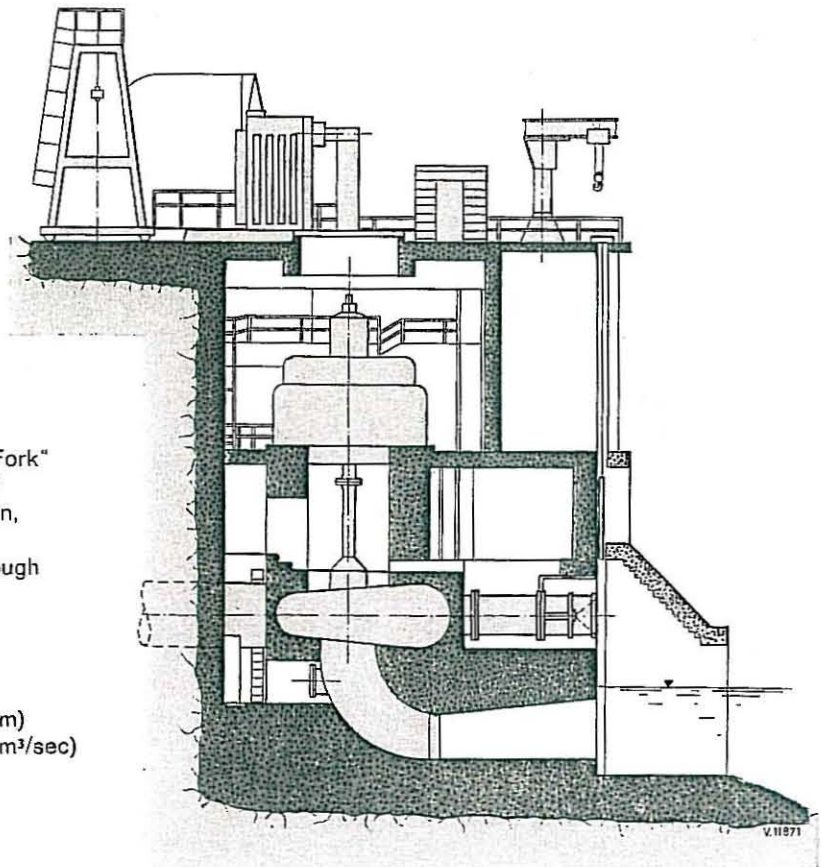

Fig. 25 Section through the Oxbow Power Station with a Francis spiral turbine from which a branch leads to a dispersion valve.

1. the operation of the turbine is not adversely affected when turbine and dispersion valve operate simultaneously at part load and
2. satisfactory dissipation of the energy is achieved when the dispersion valve operates at full load at any tailwater level,

model tests have been conducted in our Hydraulic Research Laboratory, where the optimum aeration conditions have been determined. On the basis of the model test results, the shape and dimensions of the stilling chamber have been finalized.

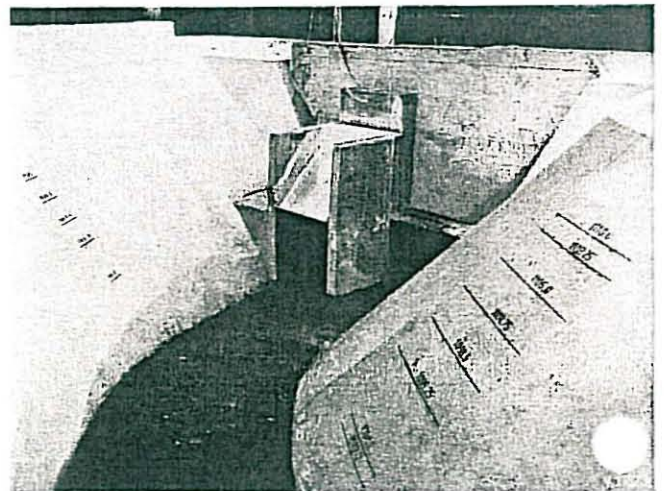

Fig. 26 Model of turbine bypass (scale 1 : 10) in our Hydraulic Research Laboratory.

Fig. 27 Section through "Oxbow" Francis spiral turbine.

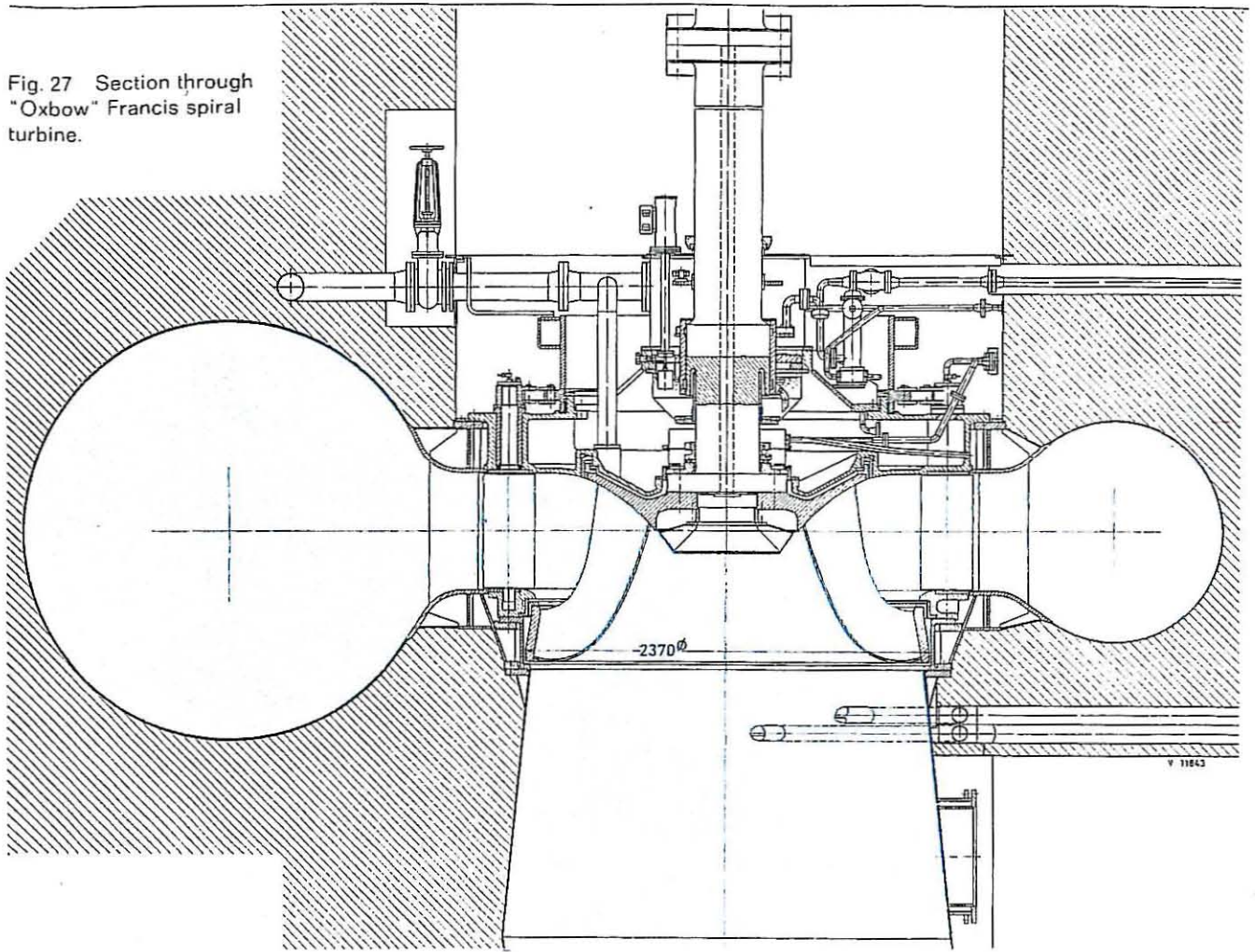
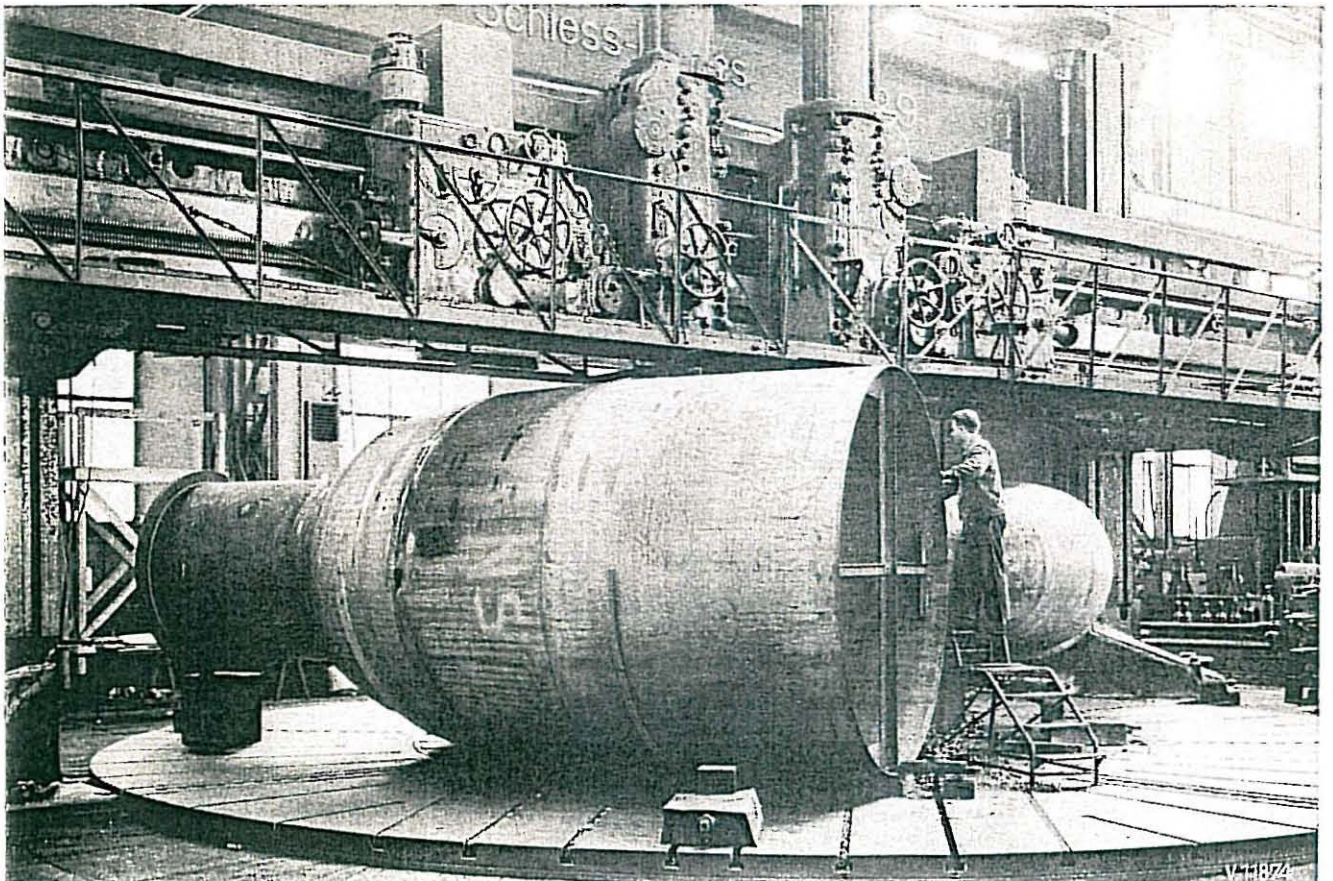

Fig. 28 Machining of the "Oxbow" spiral casing on our large vertical boring mill.



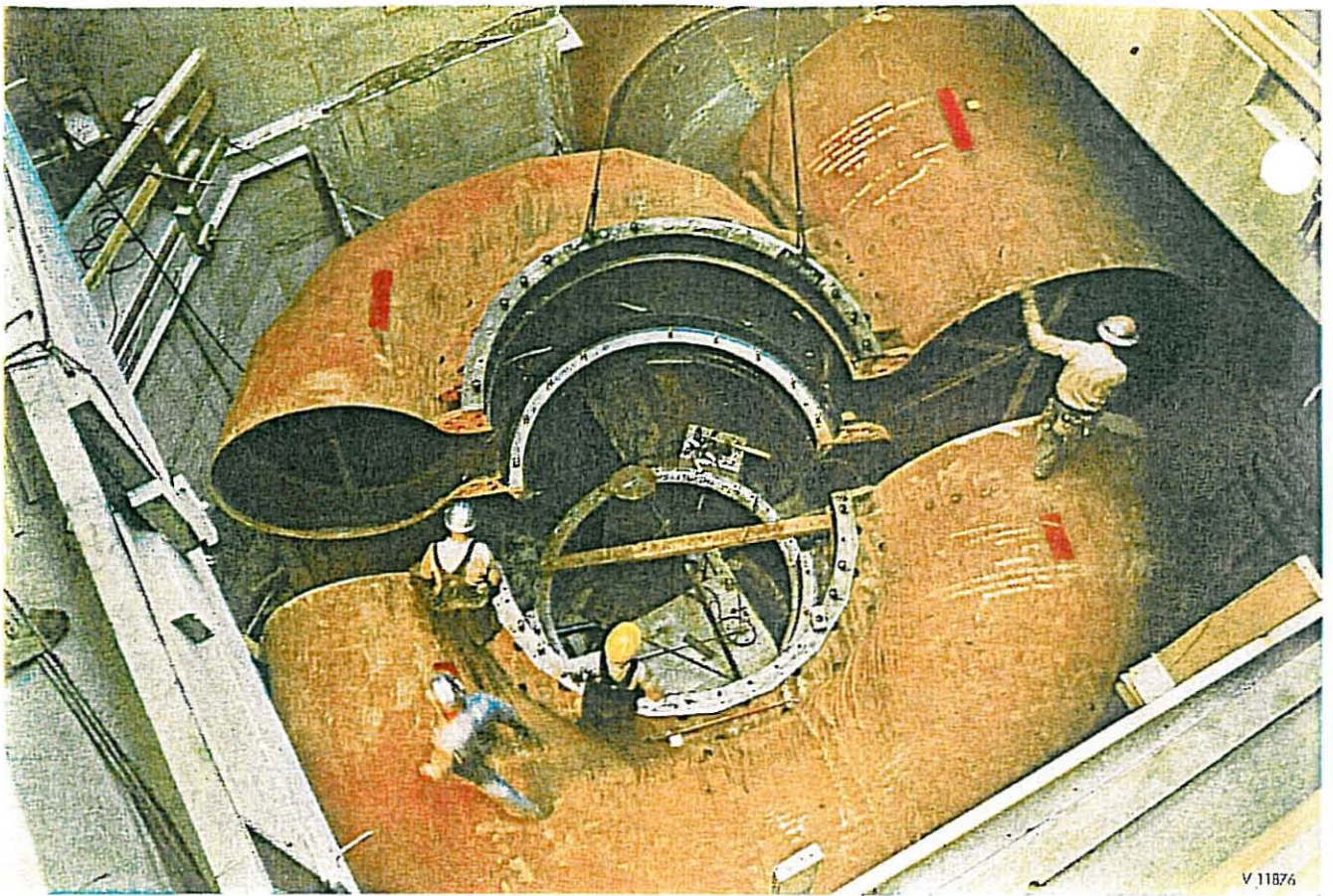

Fig. 29 Installation of the spiral casing in the Oxbow Power Station. Top centre, connection point of penstock.

Fig. 30 Oxbow Power Station nearing completion. The cover closing off the opening for the installation of the generator rotor has been lifted by the crane.

