

CL-7 voltage regulator control replacement assembly (CRA) installation instructions and service information



Powering Business Worldwide

DISCLAIMER OF WARRANTIES AND LIMITATION OF LIABILITY

The information, recommendations, descriptions and safety notations in this document are based on Eaton Corporation's ("Eaton") experience and judgment and may not cover all contingencies. If further information is required, an Eaton sales office should be consulted. Sale of the product shown in this literature is subject to the terms and conditions outlined in appropriate Eaton selling policies or other contractual agreement between Eaton and the purchaser.

THERE ARE NO UNDERSTANDINGS, AGREEMENTS, WARRANTIES, EXPRESSED OR IMPLIED, INCLUDING WARRANTIES OF FITNESS FOR A PARTICULAR PURPOSE OR MERCHANTABILITY, OTHER THAN THOSE SPECIFICALLY SET OUT IN ANY EXISTING CONTRACT BETWEEN THE PARTIES. ANY SUCH CONTRACT STATES THE ENTIRE OBLIGATION OF EATON. THE CONTENTS OF THIS DOCUMENT SHALL NOT BECOME PART OF OR MODIFY ANY CONTRACT BETWEEN THE PARTIES.

In no event will Eaton be responsible to the purchaser or user in contract, in tort (including negligence), strict liability or otherwise for any special, indirect, incidental or consequential damage or loss whatsoever, including but not limited to damage or loss of use of equipment, plant or power system, cost of capital, loss of power, additional expenses in the use of existing power facilities, or claims against the purchaser or user by its customers resulting from the use of the information, recommendations and descriptions contained herein. The information contained in this manual is subject to change without notice.

Contents

SAFETY INFORMATION	
Safety Information	iv
PRODUCT INFORMATION	
Introduction	1
Acceptance and Initial Inspection	1
Handling and Storage	1
Standards	1
Description	1
CRA Kit Components	2
INSTALLATION INSTRUCTIONS	
Making Connections to the CRA	2
SIEMENS CORPORATION VOLTAGE REGULATOR APPLICATION	
Replacement Procedure	5
GENERAL ELECTRIC (GE) VOLTAGE REGULATOR APPLICATION	
Replacement Procedure	8
HOWARD INDUSTRIES VOLTAGE REGULATOR APPLICATION	
Replacement Procedure	12
EATON'S VOLTAGE REGULATOR APPLICATION	
Replacement Procedure	15
CONTROL SETUP	
Ratio Correction	19
Ratio Correction and Control Programming	19
CONTROL PROGRAMMING	
Powering the Control Using Line Power	20
Powering the Control Using External Power	21
OPERATIONS CHECK	
Field Operations Check	21
Shop Operations Check	22



Safety for life



Eaton meets or exceeds all applicable industry standards relating to product safety in its Cooper Power™ series products. We actively promote safe practices in the use and maintenance of our products through our service literature, instructional training programs, and the continuous efforts of all Eaton employees involved in product design, manufacture, marketing, and service.

We strongly urge that you always follow all locally approved safety procedures and safety instructions when working around high voltage lines and equipment, and support our “Safety For Life” mission.

Safety information

The instructions in this manual are not intended as a substitute for proper training or adequate experience in the safe operation of the equipment described. Only competent technicians who are familiar with this equipment should install, operate, and service it.

A competent technician has these qualifications:

- Is thoroughly familiar with these instructions.
- Is trained in industry-accepted high and low-voltage safe operating practices and procedures.
- Is trained and authorized to energize, de-energize, clear, and ground power distribution equipment.
- Is trained in the care and use of protective equipment such as arc flash clothing, safety glasses, face shield, hard hat, rubber gloves, clampstick, hotstick, etc.

Following is important safety information. For safe installation and operation of this equipment, be sure to read and understand all cautions and warnings.

Hazard Statement Definitions

This manual may contain four types of hazard statements:

DANGER

Indicates an imminently hazardous situation which, if not avoided, will result in death or serious injury.

WARNING

Indicates a potentially hazardous situation which, if not avoided, could result in death or serious injury.

CAUTION

Indicates a potentially hazardous situation which, if not avoided, may result in minor or moderate injury.

CAUTION: Indicates a potentially hazardous situation which, if not avoided, may result in equipment damage only.

Safety instructions

Following are general caution and warning statements that apply to this equipment. Additional statements, related to specific tasks and procedures, are located throughout the manual.

DANGER

Hazardous voltage. Contact with hazardous voltage will cause death or severe personal injury. Follow all locally approved safety procedures when working around high- and low-voltage lines and equipment.

G103.3

WARNING

Before installing, operating, maintaining, or testing this equipment, carefully read and understand the contents of this manual. Improper operation, handling or maintenance can result in death, severe personal injury, and equipment damage.

G101.0

WARNING

This equipment is not intended to protect human life. Follow all locally approved procedures and safety practices when installing or operating this equipment. Failure to comply can result in death, severe personal injury and equipment damage.

G102.1

WARNING

Power distribution and transmission equipment must be properly selected for the intended application. It must be installed and serviced by competent personnel who have been trained and understand proper safety procedures. These instructions are written for such personnel and are not a substitute for adequate training and experience in safety procedures. Failure to properly select, install or maintain power distribution and transmission equipment can result in death, severe personal injury, and equipment damage.

G122.3

Product information

Introduction

Service Information MN225017EN provides installation instructions for Eaton's Cooper Power™ series CL-7 voltage regulator control replacement assembly (CRA). Before installing and operating this control, carefully read and understand the contents of this manual.

For installation, operation and maintenance instructions for the CL-7 voltage regulator control, refer to *Service Information MN225003EN CL-7 Voltage Regulator Control Installation, Operation, and Maintenance Instructions* for information.

Read this manual first

Read and understand the contents of this manual and follow all locally approved procedures and safety practices before installing or operating this equipment. This control is used in conjunction with a voltage regulator. Read and understand the appropriate voltage regulator instruction manual before operating this control.

Additional information

These instructions cannot cover all details or variations in the equipment, procedures, or process described nor provide directions for meeting every possible contingency during installation, operation, or maintenance. For additional information, please contact your Eaton representative.

Acceptance and initial inspection

Each CRA is completely assembled, tested, and inspected at the factory. It is in good condition when accepted by the carrier for shipment. Upon receipt, inspect the shipping container for signs of damage. Unpack the control and inspect it thoroughly for damage incurred during shipment. If damage is discovered, file a claim with the carrier immediately.

Handling and storage

Be careful during handling and storage of the control to minimize the possibility of damage. If the control is to be stored for any length of time prior to installation, provide a clean, dry storage area.

Standards

Eaton's voltage regulator controls are designed and tested in accordance with the following standards:

- IEEE Std C37.90.1™-2012 standard
- IEEE Std C37.90.2™-2004 standard
- IEEE Std C57.13™-2008 standard
- IEEE Std C57.15™-2009 standard

- IEEE Std C57.91™-2011 standard
- IEEE Std C57.131™-2012 standard
- EN 50081-2
- EN 61000-4
- IEC 60068-2
- IEC 60214-1
- IEC 60255-5

Quality standards

ISO 9001 Certified Quality Management System

IMPORTANT

CRA Applications

The CRA was designed for used on single-phase voltage regulators that utilize the following circuits:

- Control voltage or load-side voltage signal
- Motor raise and lower circuits
- Operations counter
- Common or ground
- CT current signal (optional)
- Source-side voltage signal (optional)
- Neutral light (optional)
- Drag hand reset (optional)

All of the signals listed are necessary for operation of the CRA unless otherwise noted as optional. Optional signals are required in order to utilize all features of the CL-7 control.

Description

Eaton's voltage regulator control replacement assembly (CRA) is designed to be used on single-phase regulators manufactured by Siemens® Corporation, General Electric®, and Howard Industries®, as well as Eaton's Cooper Power series type VR-32 voltage regulators.

The CRA kit utilizes the control signals common to all voltage regulators. Designed into the CRA kits are control cable connections and circuitry to enable an interface between the CL-7 control and voltage regulators not manufactured by Eaton.

CRA kit components supplied

The following is a list of the components supplied in a standard* kit:

- CL-7 voltage regulator control
- *Service Information MN225003EN, CL-7 Voltage Regulator Control Installation, Operation, and Maintenance Instructions*
- *B225-12017, CL-7 Control Reference card*
- Control box (Figure 3)
- Universal Mounting bracket and associated hardware (Figure 3)
- Back panel with associated wiring (Figure 2)
- Universal terminal designation decal. This decal provides termination point instructions for applicable voltage regulators and is located on the bottom of the control box. (See Figure 1.)
- Back Panel Tool (Figure 4)

*Components included may vary for non-standard kit assemblies.

Tools and materials required

- Socket wrench set
- Combination wrench set
- Material for marking wires
- Large adjustable wrench
- Phillips screwdriver
- Standard screwdriver
- Wire cutter
- Wire stripper
- Tools to modify control cable conduit if applicable

Before getting started

- Insure that all required tools and components are available.
- Identify the manufacturer of the regulator.
- Determine applicable control settings: note settings from control being replaced.
- Test the regulator for normal operation with the existing control panel and resolve any operational issues.
- Inspect the control cable for signs of damage and replace if necessary.

Installation

Making connections to the CRA

The CRA connections are made to terminal board TB1, located on the top of the back-panel; see Figure 2. A color-coded wiring decal clearly identifies connections; see Figure 1.

Connecting the leads to the terminal board requires using the tool supplied with the CRA assembly or an acceptable substitute; see Figure 4.

To use the tool, place it in the square hole next to the round hole where a wire is to be connected. Push the tool firmly into the hole to release the connector. Place the bare wire of the lead into the round hole, remove the tool from the square hole, and check the wire to make sure it is properly placed and is tight in the terminal board. Refer to Figure 5 for placement of the tool and the wire in the terminal board.

Label	G	R	L	OC	DHR	NL	NL2	HS	2	G	1	V2	V5	V1	V4
Siemens	E	J	K	U10	U11	U12	CPS UNIT ONLY	CPS UNIT ONLY	SOURCE CONN.	E 26 or 10	SOURCE CONN.	REG. SOURCE FROM RCT 2		REG. LOAD FROM RCT 1	
G.E.	10	27	28	30	29	31									
Cooper	G	RAISE	LOWER	OPCNTR	DHR	SIEMENS/GE UNITS ONLY	NEUT LT	HS	2	G	1	VRCT 2	V5	VRCT 1	V4

		CAUTION: DO NOT OPEN CT CIRCUIT UNDER LOAD			KnifeSwitches - Top			Knifeswitches - Bottom			Label
C2	C3	20	21	22	V6	V1	C	V6	V1	C	
CT HIGH FOR ACCESSORY		G.E. UNIT ONLY			U2	P2	C2			E1	Siemens
		20	21	22	32	20,21 or 22	Black 20AWG			White 20AWG	G.E.
C2	C3	G.E. UNIT ONLY			JBB-S4	JBB-S2	JBB-C2			JBB-C1	Cooper

Figure 1. Wiring identification decal.

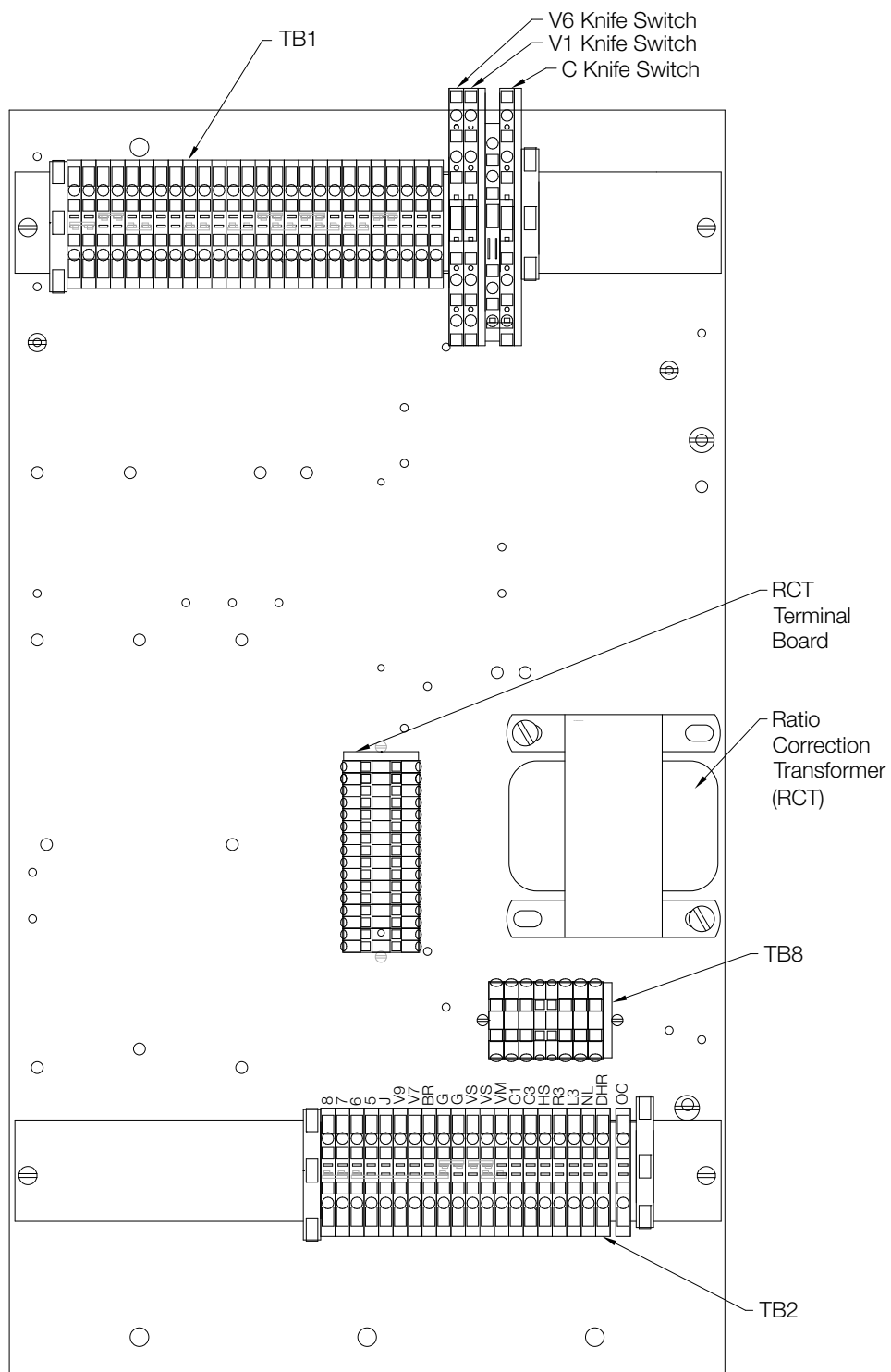

Figure 2. CRA back panel.

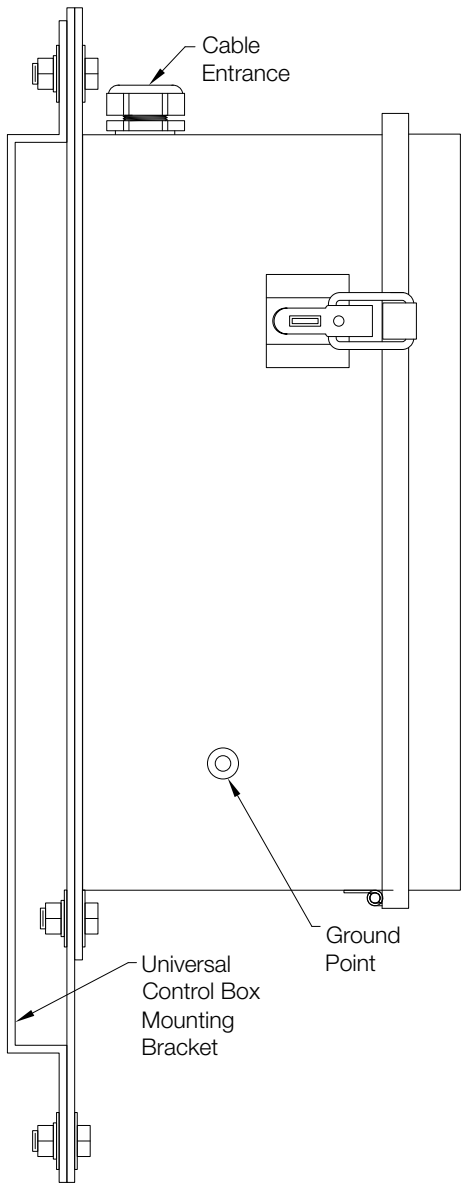

Figure 3. CRA external side view.



Figure 4. Tool supplied for connecting leads.

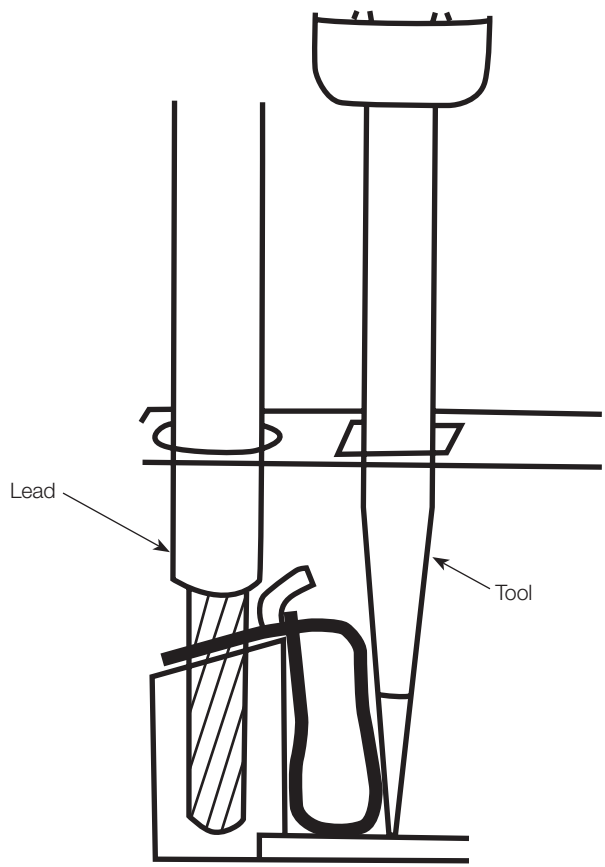

Figure 5. Connecting leads to terminal board.

Siemens® Corporation voltage regulator application

DANGER

Explosion Hazard. Voltage regulators are subject to high circulating current during bypass switching. Refer to *Service Information MN225003EN CL-7 Voltage Regulator Control Installation, Operation, and Maintenance Instructions* for information on the CRA Control, and refer to the instruction manual supplied by the voltage regulator manufacturer for specific safety procedures for bypass switching. Failure to comply will result in severe personal injury or death.

VR-T214.0

DANGER

Flashover Hazard. Opening the CT circuit under load will produce high voltages in the control box. Always bypass the regulator when installing the CRA to prevent opening the CT circuit while the regulator is under load. Failure to comply can result in severe personal injury or death.

VR-T215.0

The replacement procedure may be performed in the shop or the field. The regulator must be bypassed or removed from service prior to installing the CRA kit. Always bypass the regulator when installing the CRA kit in the field to prevent opening the CT circuit while the regulator is under load.

Note: The control cable may be an actual cable or a flexible conduit. For these instructions, it will be referred to as "control cable".

1. Bypass the regulator or remove it from service.
2. Open the existing control box and swing out the control front panel. Remove the front panel by disconnecting the jack plug and lifting the control off of its hinges.
3. If the incoming control cable leads are not marked or color-coded, place appropriate wire markers on the control cable leads and mark the leads for reference later.
4. Disconnect the incoming control cable leads from the female jack plug located on the back of the control box.

If the tap-changer motor capacitor is located in the control box, disconnect the leads from the capacitor and remove the capacitor for reinstallation in the CRA control box.

5. Remove the incoming control cable-retaining nut and remove the cable from the control box.

If the regulator is fitted with a non-flexible conduit housing the control leads, it will be necessary to modify or replace this conduit with a flexible conduit to allow interface to the CRA control box.
6. Remove the cable compression connector (cable grip) from the existing control box.
7. Remove the nameplate from the old control box

assembly and retain, with the hardware.

8. With an adjustable wrench (or appropriate socket wrench), remove and retain the bolts holding the control box on the regulator.
9. Remove the existing control box assembly from the regulator.
10. Place the supplied universal bracket over the mounting bosses of the regulator and secure with bolts retained in Step 8.
11. Place the CRA control box on the universal bracket and secure it to the regulator with bolts, washers, lock-washers, and nuts provided.

WARNING

Hazardous Voltage. The control box must be solidly earth grounded. Failure to comply can result in severe personal injury and equipment damage.

VR-T216.0

12. Attach the nameplate to the front of the CRA control box with the hardware retained in Step 7.
13. Ground the control cabinet via the ground boss located on the side of the cabinet.
14. Examine the control cable. Allow approximately 12" of lead length to protrude past the end of the conduit nut. This will facilitate connection to the top terminal strip and knife switches located in the CRA control box.
15. Remove the cable grip nut and rubber cable grommet from the cable entrance of the new control box.
16. Place the cable grip nut over the existing control cable. Select one of the two supplied cable grommets that best fits the existing cable; place the grommet over the control cable.
17. If the motor capacitor was located in the old control box, do not cut the terminals from the ends of the capacitor wires.

Cut all other terminals from the ends of the cable conductors.
18. Strip the insulation back approximately 5/16 of an inch on each lead to be connected in the new control box.
19. Insert the control cable into the control-box cable grip connector, seat the rubber grommet, and tighten the cable grip nut.
20. V6 connections and source-side PT input:
 - A. If there is no source-side PT input, or if there is a source-side PT input, but the source-side voltage is to be calculated by the control, the control box has been pre-configured for this type of operation; no further action is required.

- B. If the regulator has a source-side PT input present and it will be used to supply a source-side voltage for reverse power operation, take the following steps:
- Connect the Siemens U2 lead to the top of the V6 switch.
 - Using the supplied tool, remove the white/brown number 23 lead from the bottom section of V1 and place it at the bottom of V6.
 - FC 146 on the control must be set to Vin Mode.
 - FC 44↓ (enter function code 44 and then press the down arrow) must be set to the source-side PT ratio of the Siemens voltage regulator.
21. Connect remaining leads per Table 1 and Figures 6 and 7. A decal (see Figure 1) is located in the bottom of the control box as a reference for wiring connections from the Siemens voltage regulator to the CRA terminal board and switches. The Siemens connections are labeled in Red and Eaton's identification is labeled in Black.
22. If the motor capacitor had been located in the old control box, install and reconnect it in the CRA control box and secure the capacitor.

23. Verify that:
- The V1 and V6 knife blade switches are open.
 - The C knife blade is closed (shorted).
24. If not already installed, install the control panel on the hinges and plug in the connector.
25. Proceed to **Control Setup** section of this manual.

Table 1. CRA Connections to a Siemens Voltage Regulator

Eaton's Labels	Siemens Connection
G	E
R	J
L	K
OC	U10
DHR	U11
NL	U12
G	E
V6	U2
V1	P2
C Switch Top	C2
C Switch Bottom	E1

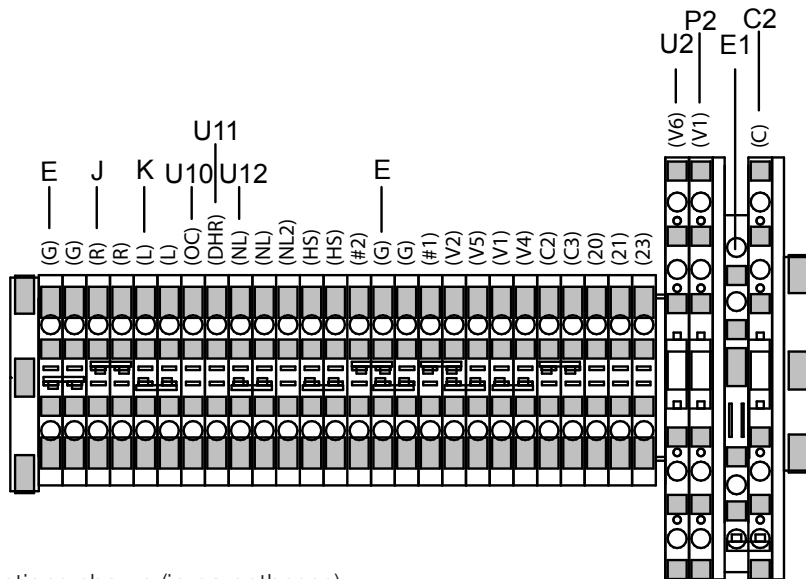

Eaton's connections shown (in parentheses)

Figure 6. TB1 Siemens connections.

Wire Color Code	
1	White
2	White
3	Orange
4	Blue
5	Blue
6	White/Green
7	White/Green
8	White/Red
9	White/Orange
10	Black
11	Black
12	White
13	Violet
14	Green
15	Red
16	Red
17	Black
18	White
19	White
20	White/Blue
21	White/Blue
23	White/Brown
24	White
25	Black
26	White/Brown
27	Brown
28	Brown
29	Red/Black
30	Blue
31	Green
32	Yellow
33	Orange
34	Red
35	Brown
36	Black
37	White

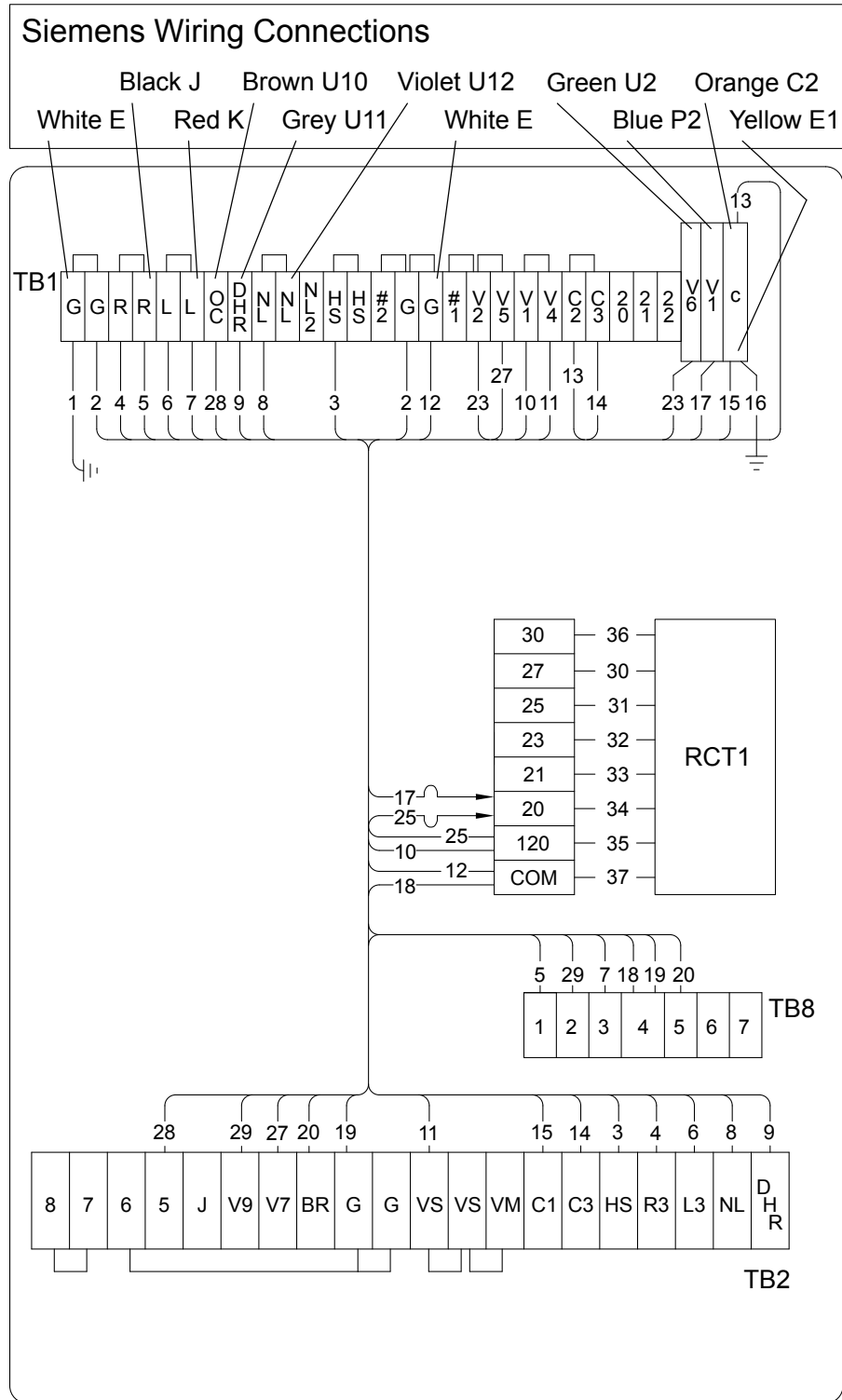

Figure 7. CRA back panel wiring to Siemens voltage regulator.

General Electric® (GE) voltage regulator application

DANGER

Explosion Hazard. Voltage regulators are subject to high circulating current during bypass switching. Refer to *Service Information MN225003EN CL-7 Voltage Regulator Control Installation, Operation, and Maintenance Instructions* for information on the CRA Control, and refer to the instruction manual supplied by the voltage regulator manufacturer for specific safety procedures for bypass switching. Failure to comply will result in severe personal injury or death. VR-T214.0

DANGER

Flashover Hazard. Opening the CT circuit under load will produce high voltages in the control box. Refer to the instruction manual provided by the voltage regulator manufacturer for specific safety procedures. Bypass the regulator when installing the CRA to prevent opening the CT circuit while the regulator is under load. Failure to comply can result in severe personal injury or death. VR-T243.0

The replacement procedure may be performed in the shop or the field. The regulator must be bypassed or removed from service prior to installing the CRA kit. Always bypass the regulator when installing the CRA kit in the field to prevent opening the CT circuit while the regulator is under load.

Note: The control cable may be an actual cable or a flexible conduit. For these instructions, it will be referred to as "control cable".

1. Bypass the regulator or remove it from service.
2. Disconnect the GE position indicator plug assembly from the bottom of the position indicator.
3. Open the existing control box and note the incoming control cable leads and associated color-coding. If the incoming control cable leads are not marked or color coded, place appropriate wire markers on the control cable leads and mark for reference later.
4. Disconnect the incoming control cable leads from the terminal strip(s) located on the back of the GE control box.

If the tap-changer motor capacitor is located in the control box, disconnect the leads from the capacitor and remove the capacitor for reinstallation in the CRA control box.

5. Remove the incoming control cable-retaining nut and remove the cable from the control box.

If the regulator is fitted with a non-flexible conduit housing the control leads, it will be necessary to modify or replace this conduit with a flexible conduit to allow interface to the CRA control box.

6. Remove the cable compression connector (cable grip) from the control box.
7. Remove the nameplate from the old control box assembly and retain, with the hardware.
8. With an adjustable wrench (or appropriate socket wrench), remove and retain the bolts holding the control box on the regulator.
9. Remove the old control box assembly from the regulator.
10. Place the supplied universal bracket over the mounting bosses of the regulator and secure with bolts retained from in Step 7.
11. Place the CRA control box on the universal bracket and secure it to the regulator with bolts, washers, lock-washers and nuts provided.

WARNING

Hazardous Voltage. The control box must be solidly earth grounded. Failure to comply can result in severe personal injury and equipment damage. VR-T216.0

12. Attach the nameplate to the front of the CRA control box with retained hardware.
13. Ground the control box using the ground boss located on the side.
14. Examine the control cable. Allow approximately 12" of lead length to protrude past the end of the conduit nut. This will facilitate connection to the top terminal strip and knife switches located in the CRA control box.
15. Remove the cable grip nut and rubber cable grommet from the cable entrance of the CRA control box.
16. Place the cable grip nut over the existing control cable. Select, one of the two supplied cable grommets that best fits the existing cable; place the grommet over the control cable.
17. If the motor capacitor was located in the old control box, do not cut the terminals from the capacitor wires. Cut all other terminals from the end of the cable conductors.
18. Strip the insulation back approximately 5/16 of an inch on each lead to be connected in the new control box.
19. Insert the control cable into the control-box cable grip connector, seat the rubber grommet, and tighten the cable grip nut.

20. V6 connections and source-side PT input:
- A. If there is no source-side PT input or if there is a source-side PT input, but the source-side voltage is to be calculated by the control, the control box has been pre-configured for this type of operation; no further action is required.
 - B. If the regulator has a source-side PT input present and it will be used to supply a source-side voltage for reverse operation, take the following steps:
 - i. Connect the GE 32 lead to the top of the V6 switch.
 - ii. Using the supplied tool, remove the white/brown number 23 lead from the bottom section of V1 and place it at the bottom of V6.
 - iii. FC 146 on the control must be set to Vin Mode.
 - iv. FC 44↓ (enter function code 44 and then press the down arrow) must be set to the source-side PT ratio of the GE voltage regulator.

21. Connect remaining leads per Table 2 and Figures 8 and 9. A decal (see Figure 1) is located in the bottom of the control box as a reference for wiring connections from the GE voltage regulator to the CRA terminal board and switches. The GE connections are labeled in Green and Eaton's identification is in Black.

Note: If the color codes do not match, check Table 2. There have been several different color code identifications used by GE over the years. If ID label numbers are used, they should apply no matter what color code system was used by GE.

22. To make the connection to the top of V1 use the black 20 AWG wire supplied in the bottom of the CRA control box. Using the tool supplied with the CRA, connect the black wire to the top of the V1 switch. Per the GE nameplate and the system voltage desired, connect the other end of the black wire to the bottom of TB1 20, or 21, or 22.
23. If the motor capacitor had been located in the old control box, install and reconnect it in the CRA control box and secure the capacitor.
24. Verify that:
- A. The V1 and V6 knife blade switches are open.
 - B. The C knife blade is closed (shorted).
25. If not already installed, install the control panel on the hinges and plug in the connector.
26. Proceed to **Control Setup** section of this manual.

Table 2. CRA Kit Connections to a GE Voltage Regulator

Eaton Labels	Old GE Connection	Connections Supplied with GE SM-3 Controls
G	White 10 (16 AWG)	White
R	Red 27	Yellow/Red
L	Green 28	Black/Red
OC	Red/Black 30	Orange/Black
DHR	Red/White 29	Blue/Black
NL	Blue/White 31	Orange/Red
G	Green/Black 26	Brown
G	Blue/Black 10	-
20	Orange/Black 20	Black
21	Orange 21	Red
22	Blue 22	Orange
V6	Black 32 (16 AWG)	Blue
V1	20, or 21, or 22	Black or Red or Orange
Top C	Black (20 AWG)	Blue/Red
Bottom C	White (20 AWG)	Red/Blue
Eaton Labels	GE Label IDs	Newer GE Connection Color Codes
G	10	Green & Yellow/Black 10
R	27	Yellow/Red
L	28	Black/Blue
OC	30	Orange/Black
DHR	29	Blue/Black
NL	31	Orange/Red
G	26 or 10	Brown, Yellow,
G	-	White
20	20	Black & Black/Red
21	21	Red & Red/Black
22	22	Orange & Brown/Red
V6	32	Brown/Black & Blue
V1	20, or 31, or 22	Bottom of 20, or 21, or 22
Top C	-	Blue/Red
Bottom C	-	Red/Blue

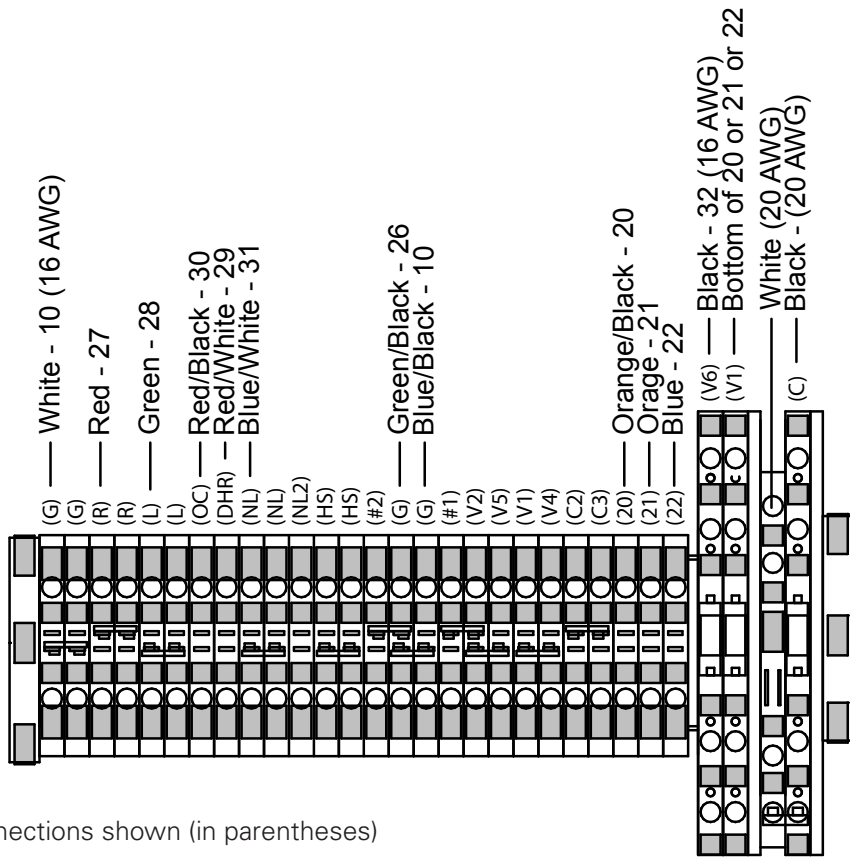

Eaton's connections shown (in parentheses)

Figure 8. TB1 GE connections.

Wire Color Code	
1	White
2	White
3	Orange
4	Blue
5	Blue
6	White/Green
7	White/Green
8	White/Red
9	White/Orange
10	Black
11	Black
12	White
13	Violet
14	Green
15	Red
16	Red
17	Black
18	White
19	White
20	White/Blue
21	White/Blue
23	White/Brown
24	White
25	Black
26	White/Brown
27	Brown
28	Brown
29	Red/Black
30	Blue
31	Green
32	Yellow
33	Orange
34	Red
35	Brown
36	Black
37	White

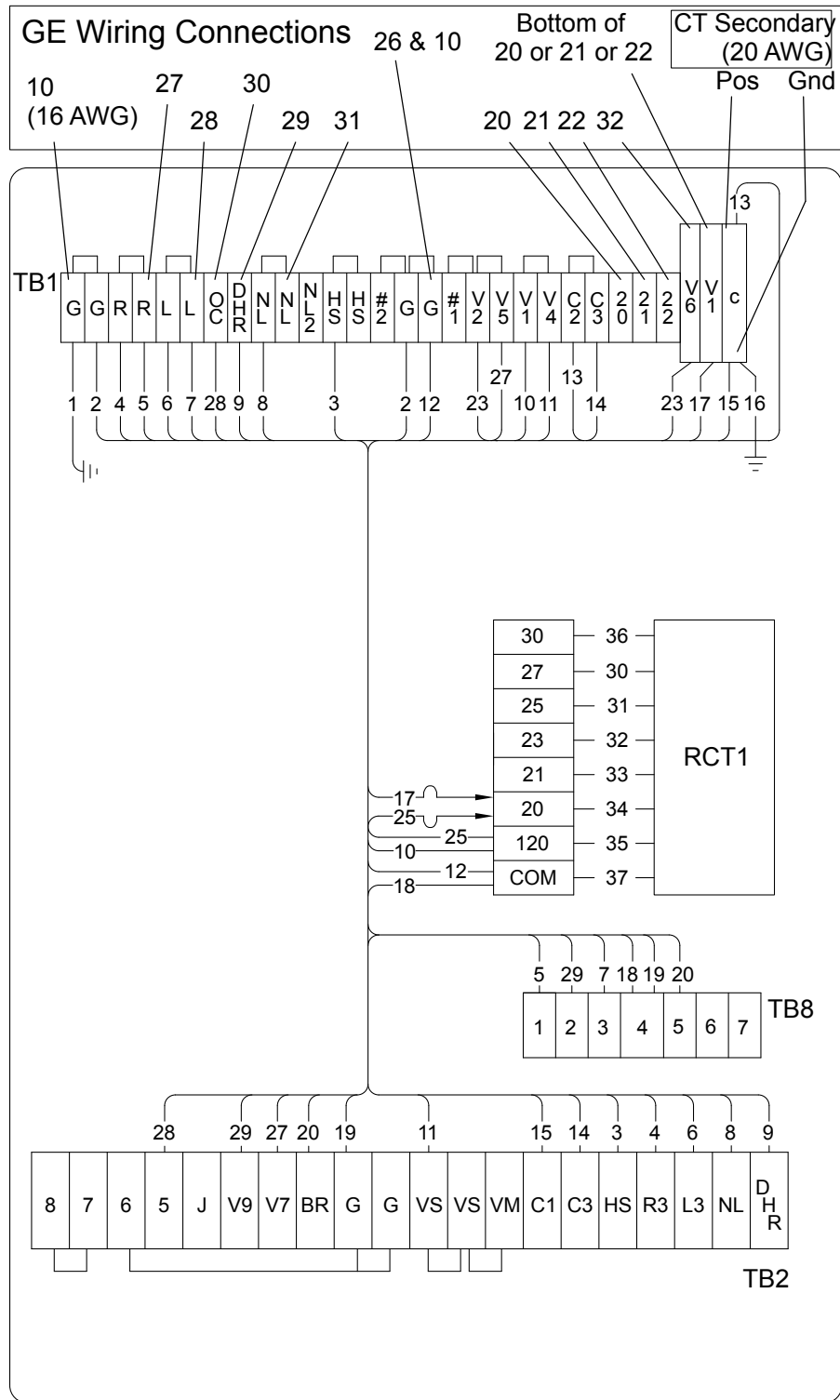

Note: If the color codes does not match, check Table 2, matching with lead number identifications. There have been several different color code identifications use by GE over the years. If ID label numbers are used, they should apply no matter what color code system was used by GE.

Figure 9. CRA kit back panel wiring for GE voltage regulator.

Howard Industries® voltage regulator application

DANGER

Explosion Hazard. Voltage regulators are subject to high circulating current during bypass switching. Refer to *Service Information MN225003EN CL-7 Voltage Regulator Control Installation, Operation, and Maintenance Instructions* for information on the CRA Control, and refer to the instruction manual supplied by the voltage regulator manufacturer for specific safety procedures for bypass switching. Failure to comply will result in severe personal injury or death.

VR-T214.0

DANGER

Flashover Hazard. Opening the CT circuit under load will produce high voltages in the control box. Always bypass the regulator when installing the CRA to prevent opening the CT circuit while the regulator is under load. Failure to comply will result in severe personal injury or death.

VR-T215.0

The replacement procedure may be performed in the shop or the field. The regulator must be bypassed or removed from service prior to installing the CRA kit. Always bypass the regulator when installing the CRA kit in the field to prevent opening the CT circuit while the regulator is under load.

1. Bypass the regulator or remove it from service.
2. Open the existing control box and swing out the control front panel. Remove the front panel by disconnecting the jack plug and lifting the control off of its hinges.
3. If the incoming control cable leads are not marked or color-coded, place appropriate wire markers on the control cable leads and mark for reference later.
4. Disconnect the incoming control cable leads from the female jack plug located on the back of the control box.
If the tap-changer motor capacitor is located in the control box, disconnect the leads from the capacitor and remove the capacitor for reinstallation in the new box.
5. Remove the incoming control cable-retaining nut and remove the cable from the control box.
6. Remove the cable compression connector (cable grip) from the control box.
7. Remove the nameplate from the old control box assembly and retain, with the hardware.
8. With an adjustable wrench or appropriate socket wrench, remove and retain the bolts holding the control box on the regulator and remove the old control box assembly from the regulator.
9. Place the supplied universal bracket over the control cabinet mounting bosses on the regulator and secure it with bolts retained in Step 8.

10. Place the CRA control box on the universal bracket and secure it to the regulator using hardware provided.
11. Attach the nameplate to the front of the CRA control box with hardware retained in Step 7.

WARNING

Hazardous Voltage. The control box must be solidly earth grounded. Failure to comply can result in severe personal injury and equipment damage.

VR-T216.0

12. Ground the control cabinet using the ground boss located on the side of the cabinet.
13. Examine the control cable. Allow approximately 12" of lead length to protrude past the end of the conduit nut. This will facilitate connection to the top terminal strip and knife switches located in the control box.
14. Remove the cable grip nut and rubber cable grommet from the cable entrance of the new control box.
15. Place the cable grip nut over the existing control cable. Select one of the two supplied cable grommets that best fits the existing cable; place grommet onto the control cable.
16. If the motor capacitor was located in the old control box, do not cut the terminals from the capacitor wires. Cut all other terminals from the end of the cable conductors.
17. Strip the insulation back approximately 5/16 of an inch on each lead to be connected in the new control box.
18. Insert the control cable into the control-box cable grip connector, seat the rubber grommet, and tighten the cable grip nut.
19. V6 connections and source-side PT input:
 - A. If there is no source-side PT input, or if there is a source-side PT input, but the source-side voltage is to be calculated by the control, the control box has been pre-configured for this type of operation; no further action is required.
 - B. If the regulator has a source-side PT input present and it will be used to supply a source-side voltage for reverse operation, take the following steps:
 - i. Connect the Howard MS lead to the top of the V6 switch.
 - ii. Using the supplied tool, remove the white/brown number 23 lead from the bottom section of V1 and place it at the bottom of V6.
20. Connect remaining leads per Table 3 and Figures 10 and 11.
21. If the motor capacitor had been located in the old control box, install and reconnect it in the CRA control box and secure the capacitor.

22. Verify that:
 - A. The V1 and V6 knife blade switches are open.
 - B. The C knife blade is closed (shorted).
23. If not already installed, install the control panel on the hinges and plug in the connector
24. Proceed to **Control Setup** section of this manual.

Table 3. CRA Kit Connections to a Howard Voltage Regulator

Eaton Labels	Howard Connections
G	G
R	R
L	L
OC	OC
DHR	DHR
NL	NS
V6*	MS
V1	PS
C Switch Top	C
C Switch Bottom	CO

* If the MS lead is used as a motor power source, it will not be used. The motor power and sensing voltage sources will both be supplied to the control through the PS lead.

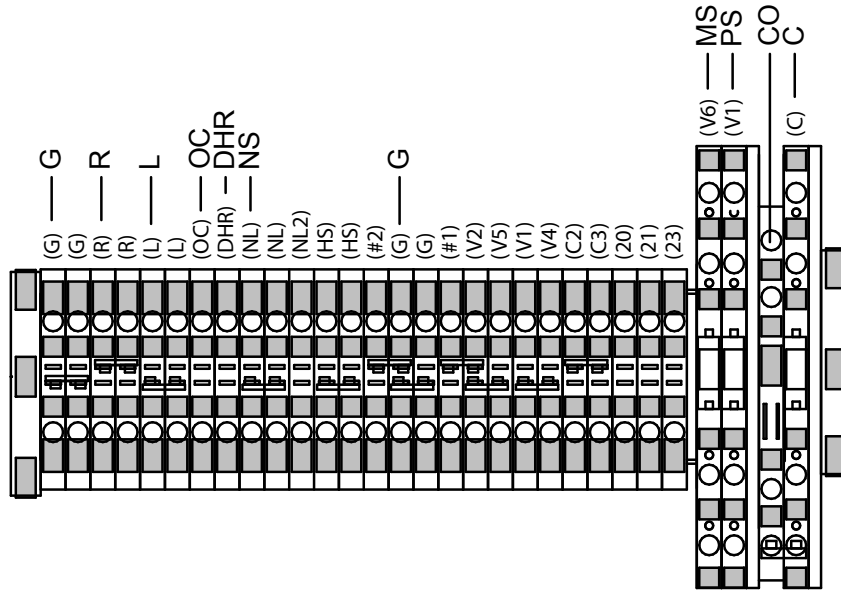

Figure 10. TB1 Howard connections.

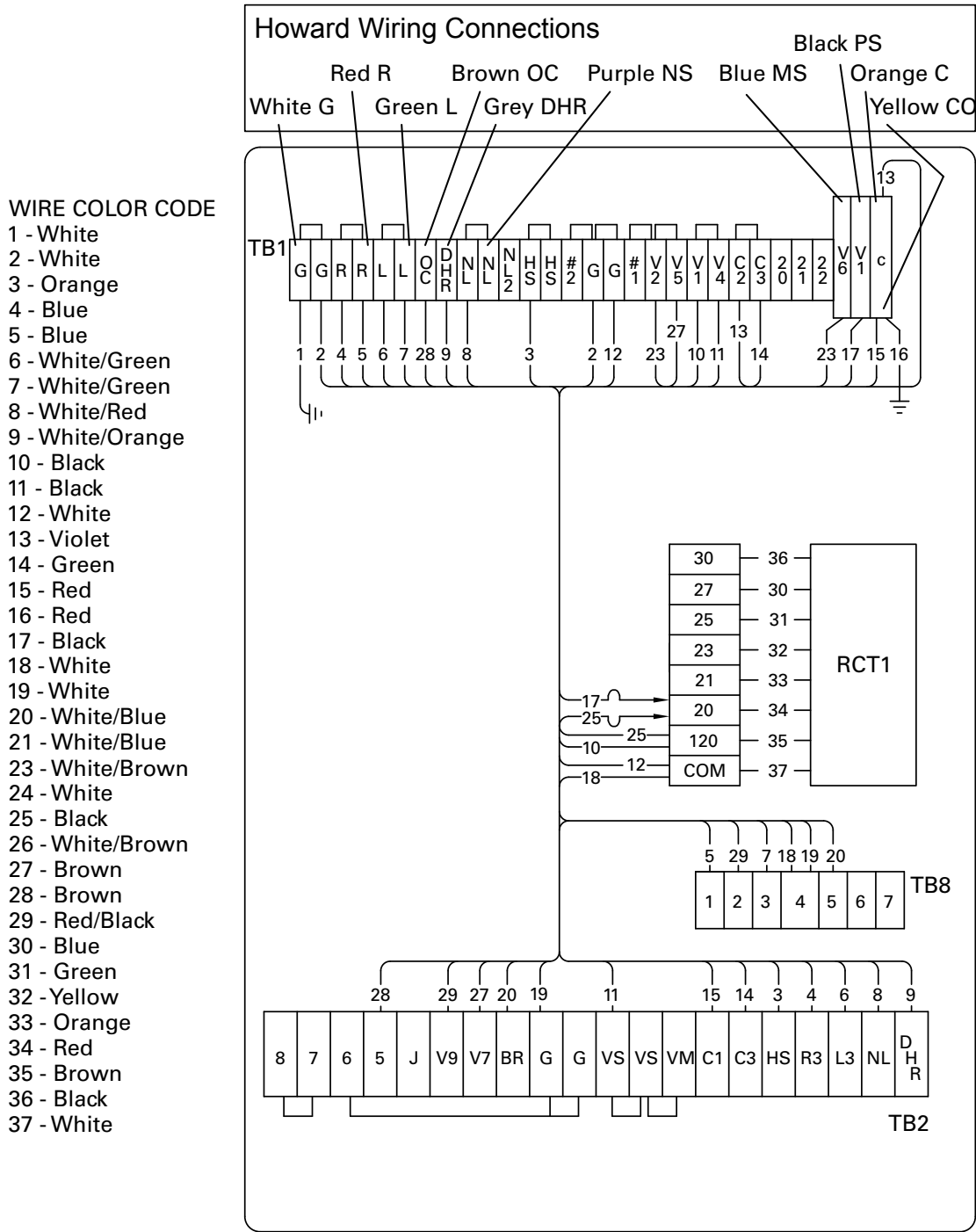

Figure 11. CRA back panel wiring for Howard voltage regulator.

Eaton's voltage regulator application

DANGER

Explosion Hazard. Voltage regulators are subject to high circulating current during bypass switching. Refer to *Service Information MN225003EN CL-7 Voltage Regulator Control Installation, Operation, and Maintenance Instructions* for information on the CRA Control, and refer to the instruction manual supplied by the voltage regulator manufacturer for specific safety procedures for bypass switching. Failure to comply will result in severe personal injury or death.

VR-T214.0

DANGER

Flashover Hazard. Opening the CT circuit under load will produce high voltages in the control box. Always bypass the regulator when installing the CRA to prevent opening the CT circuit while the regulator is under load. Failure to comply can result in severe personal injury or death.

VR-T215.0

The CRA can be placed on Eaton and McGraw-Edison voltage regulators by following the procedure given in this section. The CRA is primarily designed as a control replacement on voltage regulators not manufactured by Eaton. Control replacement for Eaton and McGraw-Edison voltage regulators with a quick-disconnect control cable can be simplified by using a standard replacement control. Pricing and availability for standard replacement control assemblies can be obtained by contacting your Eaton representative.

The replacement procedure may be performed in the shop or the field. The regulator must be bypassed or removed from service prior to installing the CRA. Always bypass the regulator when installing the CRA in the field to prevent opening the CT circuit while the regulator is under load.

1. Bypass the regulator and remove it from service.
2. Open the existing control box and swing out the control panel.
3. Remove the existing control panel.
4. There are two control cable scenarios:
 - A. If replacing a control with a quick-disconnect control cable, it may be possible to use the quick-disconnect pigtail and connector. Do so by following these steps:
 1. Disconnect the control cable quick-disconnect connector from the inside of the control box.
 2. If the incoming control cable leads are not marked or color coded, place appropriate wire markers on the control cable leads to mark it for later reference.
 3. Disconnect the incoming pigtail leads from the terminal block and knife switches on the back panel and remove the pigtail from the box.

4. Remove the nut on the inside of the control box that attaches the control cable to the control box. Retain the nut, washer from the inside of the control box and the rubber gasket from the outside of the control box.
- B. If replacing a control with a hardwired control cable:
 1. If the incoming control cable leads are not marked or color coded, place appropriate wire markers on the control cable leads to mark it for later reference.
 2. Disconnect the incoming control cable leads from the terminal blocks and knife switches on the back panel.
 3. Remove the control cable from the existing control box.
5. Remove the nameplate from the old control box assembly and retain it with the hardware.
6. With the adjustable wrench or appropriate socket wrench, remove and retain the bolts holding the old control box on the regulator and remove the old control box assembly from the regulator.
7. Remove the supplied universal control box mounting bracket (see Figure 3) from the CRA control box.
8. In the majority of installations, the universal bracket will not be required. In the event the CRA control box does not mount directly to the Eaton/McGraw-Edison regulator, the universal bracket may be altered to accommodate hole and/or drill patterns.
9. Place the CRA control box on the regulator and secure it with the appropriate hardware.
10. Reattach the nameplate to the front of the CRA control box. The nameplate bracket may be removed and the Eaton/McGraw-Edison nameplate affixed directly to the CRA control box.

WARNING

Hazardous Voltage. The control box must be solidly earth grounded. Failure to comply can result in severe personal injury and equipment damage.

VR-T216.0

11. Ground the control cabinet via the ground boss located on the side of the cabinet.
12. Control cable installation:
 - A. Quick-disconnect control cable:
 1. Remove the cable grip from the top of the CRA control box and install the quick disconnect connector from the control cable into the hole. Be sure to properly seat the gasket between the top of the control box and connector.
 2. Tighten the control cable connector from the inside of the control box using the nut and washer retained earlier.

3. Examine the pigtail retained earlier. If the motor capacitor was located in the old control box, do not cut the terminals from the capacitor wires.
 4. Cut all other terminals (if present) from the end of the cable conductors.
 5. Strip the insulation back approximately 5/16 of an inch on each lead to be connected in the new control box.
- B. Hard-wire control cable:
1. Examine the control cable. Allow approximately 12" of lead length to protrude past the end of the cable insulation. If necessary, strip some of the outer insulation.
 2. Remove the cable grip nut and rubber cable grommet from the cable entrance of the new control box.
 3. Place the cable grip nut over the existing control cable. Select one of the two supplied cable grommets that best fits the existing cable; place the grommet onto the control cable.
 4. If the motor capacitor was located in the old control box, do not cut the terminals from the capacitor wires.
 5. Cut all other terminals from the end of the cable conductors.
 6. Strip the insulation back approximately 5/16 of an inch on each lead to be connected in the new control box.
 7. Insert the control cable into the control-box cable grip connector, seat the rubber grommet and tighten the cable grip nut.
13. V6 connections and source-side PT input:
- A. If there is no source-side PT input or if there is a source-side PT input, but the source-side voltage is to be calculated by the control, the control box has been pre-configured for this type of operation; no further action is required.
 - B. If the regulator has a source-side PT input present and it will be used to supply a source-side voltage for reverse operation, take the following steps:
 - i. Connect the white/black lead to the top of the V6 switch.
 - ii. Using the supplied tool, remove the white/brown number 23 lead from the bottom section of V1 and place it at the bottom of V6.
 - iii. FC 44↓ (enter function code 44 and then press the down arrow) must be set to the Internal PT ratio value found on the nameplate for the system voltage.
14. Connect the remaining leads per Figures 13 and 14. A decal (see Figure 4) is located in the bottom of the control box as a reference for wiring connections from Eaton's voltage regulator to the CRA terminal board and switches. Eaton's connections are labeled in black.
 15. If the motor capacitor had been located in the old control box, install and reconnect it in the CRA control box and secure the capacitor.
 16. Verify that:
 - A. The V1 and V6 knife blade switches are open.
 - B. The C knife blade is closed (shorted).
 17. If not already installed, install the control panel on the hinges and plug in the connector.
- 18. Important Step!** When installing the a CL-7 regulator on McGraw-Edison voltage regulator manufactured in 1988 and earlier, it will be necessary to flip a switch on the side of the control (see Figure 12). The switch must be in the down position for the older regulators; the neutral light will stay on all the time if it is not.
19. Proceed to **Control Setup** section of this manual.

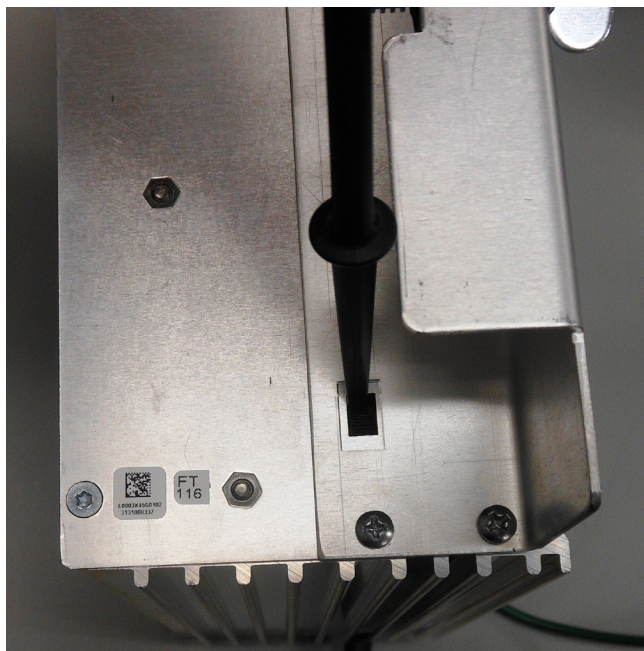

Figure 12. Neutral light source switch on CL-7 control.

Table 4. CRA Kit Connections for Eaton/McGraw Edison Voltage Regulators

Connection Point	Wire Color
V1	Black
G	White
C (bottom)	Red
C (top)	Green
HS	Orange
R1	Blue
V6	White/Black
NL	Red/Black
L1	Green/Black
DHR	Orange/Black
Motor Cap 1	Lt Blue/Black
Motor Cap 2	Black/White

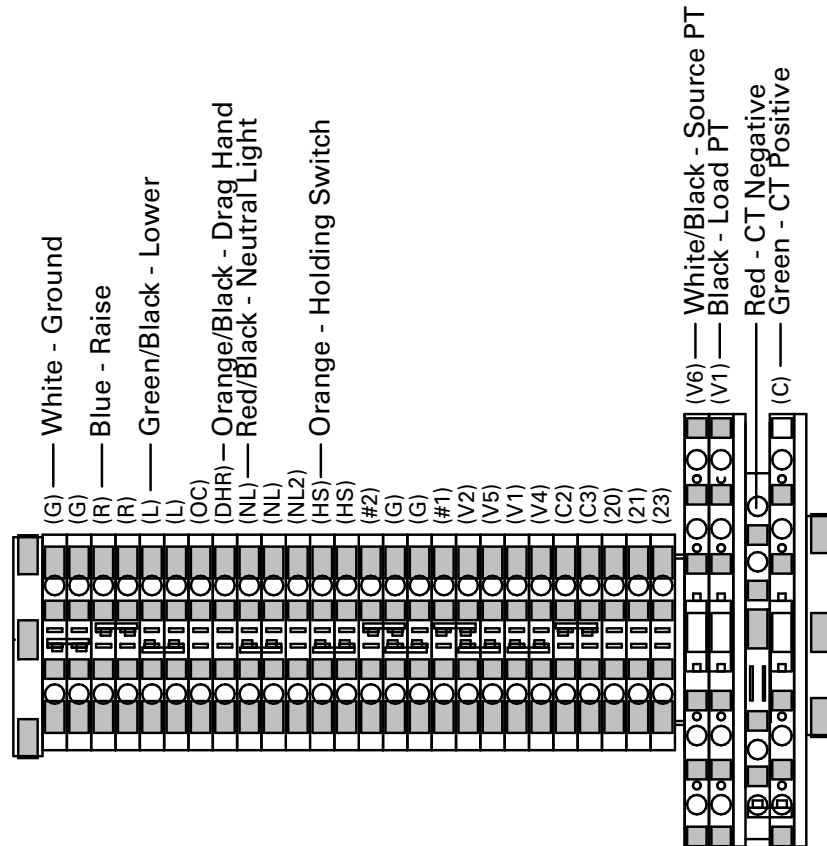

Figure 13. TB1 Eaton's connections.

WIRE COLOR CODE

- 1 - White
- 2 - White
- 3 - Orange
- 4 - Blue
- 5 - Blue
- 6 - White/Green
- 7 - White/Green
- 8 - White/Red
- 9 - White/Orange
- 10 - Black
- 11 - Black
- 12 - White
- 13 - Violet
- 14 - Green
- 15 - Red
- 16 - Red
- 17 - Black
- 18 - White
- 19 - White
- 20 - White/Blue
- 21 - White/Blue
- 23 - White/Brown
- 24 - White
- 25 - Black
- 26 - White/Brown
- 27 - Brown
- 28 - Brown
- 29 - Red/Black
- 30 - Blue
- 31 - Green
- 32 - Yellow
- 33 - Orange
- 34 - Red
- 35 - Brown
- 36 - Black
- 37 - White

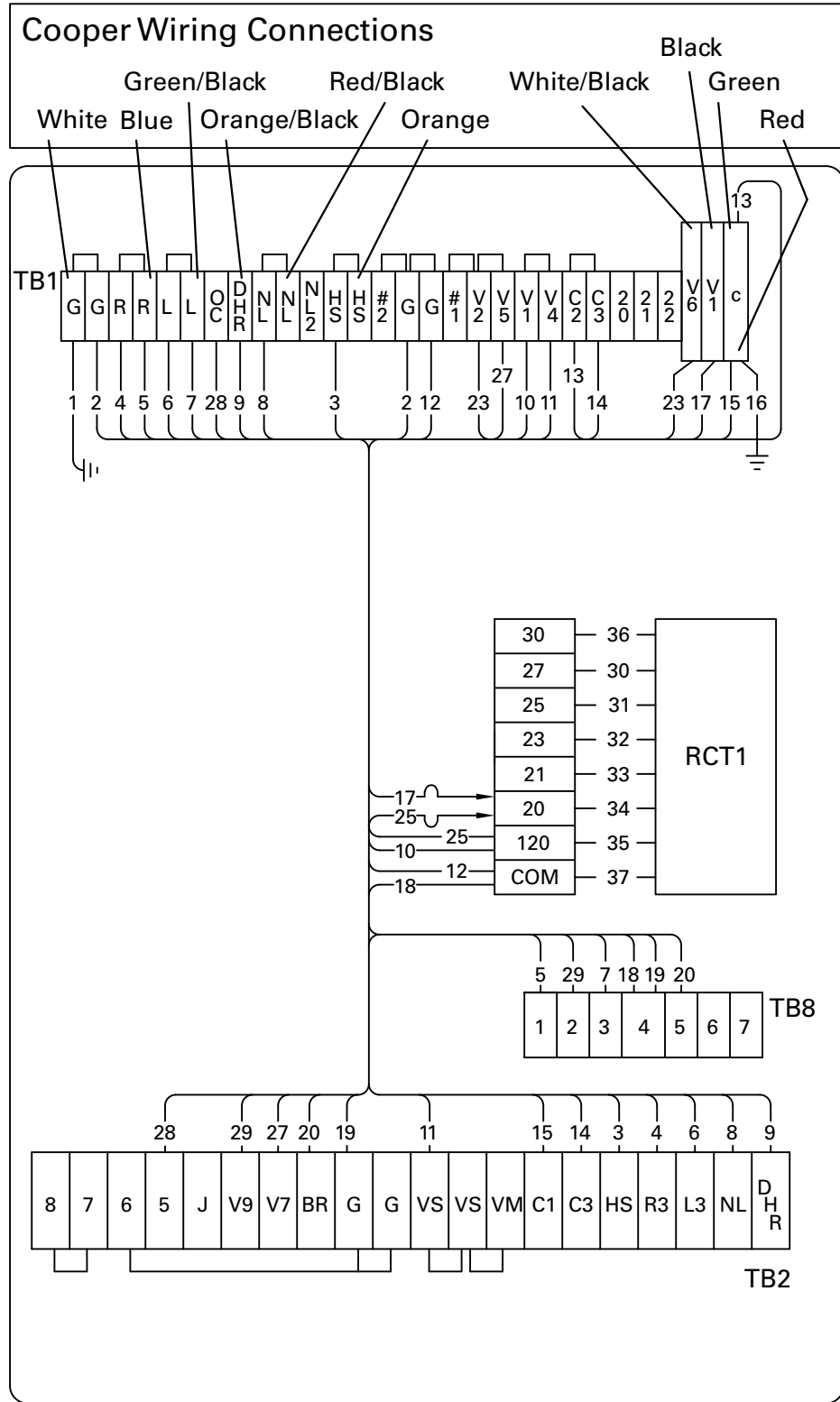

Figure 14. CRA back panel wiring for Eaton's voltage regulator.

Control setup

Ratio correction

It may be necessary to "ratio correct" the control voltages from the regulator. Ratio correction is a fine adjustment of the load side voltage signal to an approximate 120 volt base. The adjustment is made using the ratio correction transformer (RCT). The magnitude of the voltage signal coming to the control box is dependent upon the system voltage applied to the regulator and the regulators internal potential transformer ratio. The application of the RCT allows for the fine adjustment of the incoming voltage as near as possible to 120 volts. The CRA is designed to work with the 120 volt signal from the load side of any regulator. The CL-7 control does not require a fine adjustment to the source-side or differential voltage signal, but instead uses the internal PT ratio and software correction to determine the source side voltage.

Note: The CRA is shipped from the factory set for no ratio correction. Examine the regulator nameplate to determine if ratio correction is required for your application.

If the regulator nameplate indicates that the load control signals at nominal system voltage are something other than 120 volts, such as 115, 125, etc., it will be necessary to utilize the RCT located on the back panel of the CRA. See Figure 2. Ratio correction is achieved by applying the load voltage signals to the RCT autotransformer to adjust the output as near as possible to 120 volts. How much ratio correction required can be determined by using the internal PT ratio and system voltage and then determining the required ratio of the RCT.

Ratio correction and control programming

Source voltage control signal (when present)

If the regulator is supplied with a source-side signal (Siemens green "U2"; GE #16AWG black 32; Eaton/McGraw-Edison white/black) the appropriate lead will be terminated on the top of the V6 knife switch. Ratio correction is not required, but the correct internal PT ratio must be entered into the control. The control must also be set up to recognize the signal sent from the PT.

CAUTION

Over-voltage hazard. Equipment damage. Insure that the nominal PT voltage plus 10% does not exceed 140 Vac. In such a case, do not connect the source PT, but instead use the source-voltage calculation. A source-PT voltage above 150 Vac will result in equipment damage. VR-T244.0

1. Determine the internal PT ratio by dividing the nominal system voltage by the control source voltage and entering this value at FC 44↓ (enter function code 44 and then press the down arrow). On Eaton/McGraw-Edison regulators, the internal PT ratio can be read from the voltage chart.

Example: If the regulator nameplate lists a control source voltage of 120 volts for a system voltage of 7620, the Internal PT Ratio will be $7620/120 = 63.5$.

2. The Vin PT Setting must be correctly set at FC 146. Select the correct setting as follows:
 - Select Vdiff without RCT2 when an internal differential PT (IDPT) supplies the source-side voltage by measuring the voltage difference between the source and the load. This is standard for Eaton/McGraw-Edison voltage regulators.
 - Select Vin if the a source-side PT provides a voltage signal measured between the source and source/load. This is standard on voltage regulator manufactured by Siemens and GE.

Load control signal (always present)

The regulator will be supplied with a load-side signal (Siemens blue "P2"; GE 20 orange/black or 21 orange or 22 blue; Eaton/McGraw-Edison black). The appropriate lead will be terminated on the top of the V1 knife switch. The RCT must be set up correctly and the Overall PT Ratio must be set in the control.

Note: Some Siemens type A regulators may not be equipped with a load control signal. Eaton's control will not work on such devices.

1. If the regulator nameplate identifies the load control signal as 120 volts for the system voltage used, no ratio correction is necessary. Determine the Overall PT ratio by dividing the nominal system voltage by the control voltage and enter this value at FC 44. This value is listed on Eaton/McGraw-Edison nameplates in the voltage chart for the appropriate system voltage.

Example: If the regulator nameplate lists a control voltage of 120 volts for a system voltage of 7620, the Overall PT Ratio will be $7620/120 = 63.5$.

- If the regulator nameplate identifies the load control signal as a value other than 120 volts for the system voltage used, set the ratio correction using RCT1 as show in the following examples:

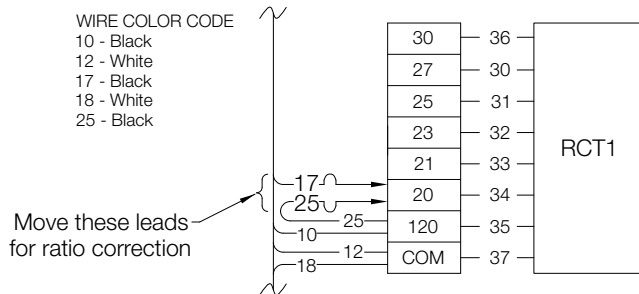

Figure 15. Ratio Correction Transformer connections.

Example 1: If the control voltage is listed as 115 V:

- Calculate $115 - 120 = -5$ volts.
- Obtain a -5 difference by placing lead # 17 on **RCT1 - 20** and placing lead # 25 (the end not connected to the 120 terminal on the RCT terminal block) on **RCT1 - 25** ($20 - 25 = -5$ volts). See Figure 15.
- The Overall PT ratio entered at FC 44 would be determined by dividing the system voltage by the "ratio corrected" control voltage. For example: If the system voltage is 7620 and the control voltage was corrected to 120 V, the Overall PT Ratio will be $7620/120 = 63.5$.

Example 2: If the control voltage is listed as 125 V:

- Calculate $125 - 120 = +5$ volts.
- Obtain a +5 difference by placing lead # 17 on **RCT1 - 25** and place lead # 25 (the end not connected to the 120 terminal on the RCT terminal block) on **RCT1 - 20** ($25 - 20 = +5$ volts). See Figure 15.
- The Overall PT ratio entered at FC 44 would be determined by dividing the system voltage by the "ratio corrected" control voltage. For example: If the system voltage is 7620 and the control voltage was corrected to 120 V, the Overall PT Ratio will be $7620/120 = 63.5$.

- If the regulator nameplate identifies the control signal as other than 120 volts, but it is not able to exactly be corrected to 120 volts, select the RCT compensation that will correct it as close as possible to 120 V. The Overall PT Ratio would be calculated by dividing the system voltage by the ratio corrected control voltage.

Example: If the control voltage is listed as 123.5:

- Calculate $123.5 - 120 = +3.5$ volts
- Obtain a +3 difference by placing lead #17 on **RCT1 - 23** and placing lead #25 (the end not connected to the 120 terminal on the RCT terminal block) on **RCT1 - 20** ($23 - 20 = +3$ volts). See Figure 15.

- The Overall PT ratio entered at FC 44 would be determined by dividing the system voltage by the "ratio corrected" control voltage. In this example, the control voltage was corrected by 3 volts and will be $123.5 - 3.0 = 120.5$. If the system voltage is 7620, the Overall PT Ratio will be $7620/120.5 = 63.2$.

Control programming

Once the control is installed, power the control for programming.

Powering the control using line power

The control can be powered for programming by connecting the regulator to the power distribution lines. It is important to perform the following steps before beginning this process so that the regulator does not begin to operate before it is programmed:

- Open the V1 (and V6 if present) switches on the back panel
- POWER switch set to OFF
- CONTROL FUNCTION switch set to OFF
- Remove the 6-amp motor fuse

DANGER

Explosion Hazard. Voltage regulators are subject to high circulating current during bypass switching. Refer to Service Information MN225003EN Voltage Regulator CL-7 Series Control Installation, Operation, and Maintenance Instructions for information on the CRA Control, and refer to the instruction manual supplied by the voltage regulator manufacturer for specific safety procedures for bypass switching. Failure to comply will result in severe personal injury or death.

VR-T214.0

There are two scenarios for powering using line power:

- Bypass switching is performed using 3 separate switches: If the bypass switches being used are not single-pull type, the control can be powered by closing the source switch only.
- Bypass switching with a single-pull switch or 3 separate switches: The control can be powered by closing the disconnect switches, opening the bypass switch and putting the regulator fully into service. Use locally approved processes for regulator installations. Make sure that the regulator is in the neutral position before starting the process.

To power the control, while the CONTROL FUNCTION switch remains in the OFF position, close the V1 switch on the back panel and move the POWER switch to the INTERNAL position.

Powering the control using external power

The control can be powered using an external power sources. Before applying an external source, perform the following steps to insure that the regulator does not operate and step off of neutral before installation:

1. Open the V1 (and V6 if present) switches on the back panel
2. Set POWER switch to OFF
3. Set CONTROL FUNCTION switch to OFF
4. Remove the 6-amp motor fuse

DANGER

Explosion Hazard. Voltage regulators are subject to high circulating current during bypass switching. Refer to *Service Information MN225003EN Voltage Regulator CL-7 Series Control Installation, Operation, and Maintenance Instructions* for information on the CRA Control, and refer to the instruction manual supplied by the voltage regulator manufacturer for specific safety procedures for bypass switching. Failure to comply will result in severe personal injury or death. VR-T214.0

For detailed instructions on externally powering of a voltage regulator control, refer to *Service Information MN225003EN CL-7 Voltage Regulator Control Installation, Operation, and Maintenance Instructions* for information.

WARNING

Hazardous Voltage. When applying external power to a control, an isolated power supply must be used. If the power supply is not isolated and is connected with the incorrect polarity, it will cause the 120 Vac supply voltage to be shorted to ground. This can result in a shock hazard, damage to the control, damage to regulator componentry, and damage to the power supply. VR-T245.0

1. Place 120 volts to the EXTERNAL SOURCE terminals located on the control front panel. Be certain the voltage polarity is correct when applying power to the control - positive to the black terminal, neutral to the white terminal and ground to green.
2. While the CONTROL FUNCTION switch remains in the OFF position, move the POWER switch to the EXTERNAL position.

After applying power, the control can be programmed. Programming of the CRA control front panel is covered in the Service literature shipped with the CRA. The standard control sent with a CRA is Eaton's CL-7 control. *Bulletin B225-12017 CL-7 Control Reference* is a guide to the basic controls settings and functionality. For more complete information, consult *Service Information MN225003EN CL-7 Voltage Regulator Control Installation, Operation and Maintenance Instructions*.

IMPORTANT

Pay particular attention to correctly setting FC 49. This settings should be set to match the manufacture of the voltage regulator and/or the correct tap-changer type.

Operations check

After control programming is complete, an operations check should be performed to confirm correct functioning of the CRA. The operations check can be performed on the regulator while in the shop or in the field.

Field operations check

The voltage regulator operations checks can be performed in the field by connecting to line power. The regulator may be powered by closing the disconnect switches, opening the bypass switch and putting the regulator into full operation or if possible, powered by closing the source-side disconnect switch while maintaining a closed bypass switch and opened load-side disconnect switch.

IMPORTANT

Carefully read the steps and warnings before performing any operations checks.

DANGER

Explosion Hazard. Voltage regulators are subject to high circulating current during bypass switching. Refer to *Service Information MN225003EN Voltage Regulator CL-7 Series Control Installation, Operation, and Maintenance Instructions* for information on the CRA Control, and refer to the instruction manual supplied by the voltage regulator manufacturer for specific safety procedures for bypass switching. Failure to comply will result in severe personal injury or death. VR-T214.0

To apply line power to the control there are two methods:

1. When bypass switching is performed using 3 separate switches: If the bypass switches being used are not single-pull type, line power can be applied by closing the source switch only. Once the source disconnect switch is closed, apply power to the control by closing the V1 switch on the back panel.

DANGER

The operations check involves switching the voltage regulator off of the neutral position. This can safely be done with the source disconnect switch and bypass switch closed and the load disconnect switch open. Once the operations check is completed, the regulator must be returned to the neutral position and the position verified using three independent methods before the regulator is bypassed into service. Failure to do so can result in serious injury or death. VR-T246.0

2. Putting the regulator into service: Using any type of bypass switch (single-pull or individual switches), power can be applied by closing the disconnect switches, opening the bypass switch and putting the regulator fully into service. Make sure that the regulator is in the neutral position before starting the process and verify this by using three independent methods. Use locally

approved processes to put the voltage regulator into service. Once the regulator is in service, apply power to the control by closing the V1 switch on the back panel.

Once line power has been connected, perform the operations check:

1. Replace the motor fuse.
2. Set the control POWER switch to INTERNAL.
3. Set the CONTROL FUNCTION switch to LOCAL MANUAL.
4. Enter FC 12 – Present Tap Position.
5. While monitoring FC 12, lower the tap position by pressing the LOWER control switch. The displayed tap position will decrease and the regulator will lower one tap position.
6. Lower the regulator until the LOW out of band indication is observed.
7. Place the CONTROL FUNCTION switch into the AUTO/REMOTE position. The regulator will time-out per the time-delay value entered at FC 3, then will tap up until back into band.
8. Repeat the process by manually tapping to out-of-band high.
9. Return the regulator to the NEUTRAL position by pressing the appropriate RAISE or LOWER control switch. The NEUTRAL LIGHT will illuminate.
10. Check the drag hand reset circuit by depressing the DRAG HAND RESET switch. The drag hands located in the position indicator will reset to the position indicator pointer position.
11. Returned to the regulator to the neutral position when testing is complete.

 **DANGER**

Explosion Hazard. Voltage regulators are subject to high circulating current during bypass switching. Refer to *Service Information MN225003EN Voltage Regulator CL-7 Series Control Installation, Operation, and Maintenance Instructions* for information on the CRA Control, and refer to the instruction manual supplied by the voltage regulator manufacturer for specific safety procedures for bypass switching. Failure to comply will result in severe personal injury or death.

VR-T214.0

Shop operations check

The shop operations check is essentially identical to the field check except that it is performed in the shop using a 120 volt power supply instead of using line power to power the control. With a properly functioning control panel and properly connected power supply, the high voltage bushings on the regulator will NOT be energized via a back-fed control signal. However, it is recommended that the bushings be connected to ground as a safety precaution when performing any control panel powered testing.

For detailed instructions on externally powering of a voltage regulator control, refer to *Service Information MN225003EN CL-7 Voltage Regulator Control Installation, Operation, and Maintenance Instructions* for information.

 **WARNING**

Hazardous Voltage. When applying external power to a control, an isolated power supply must be used. If the power supply is not isolated and is connected with the incorrect polarity, it will cause the 120 Vac supply voltage to be shorted to ground. This can result in a shock hazard, damage to the control, damage to regulator componentry, and damage to the power supply.

VR-T245.0

To power the control for the operations test:

1. Make sure that the V1 switch on the back panel is open.
2. Connect 120 Vac to the EXTERNAL SOURCE terminals located on the control front panel. Be certain the voltage polarity is correct when applying power to the control - positive to the black terminal, neutral to the white terminal and ground to green.

With 120 volts applied to the external source terminals, perform the following:

1. Replace the motor fuse.
2. Place the control POWER switch to EXTERNAL.
3. Place the CONTROL FUNCTION switch to LOCAL MANUAL.
4. Enter FC 12 on the control keypad – Present Tap Position.
5. While monitoring FC 12 lower the regulator by pressing the LOWER control switch. The displayed tap position will decrease and the regulator will lower one tap position.
6. While monitoring FC 12, return the regulator to its original tap position by pressing the RAISE control switch.
7. Check the drag hand reset circuit by depressing the DRAG HAND RESET switch. The drag hands located in the position indicator will reset to the position indicator pointer position.
8. Check the neutral light circuit by manually raising or lowering the regulator to the NEUTRAL position. The NEUTRAL LIGHT will illuminate.
9. Returned to the regulator to the neutral position when testing is complete.



DANGER

Explosion Hazard. Voltage regulators are subject to high circulating current during bypass switching. Refer to *Service Information MN225003EN Voltage Regulator CL-7 Series Control Installation, Operation, and Maintenance Instructions* for information on the CRA Control, and refer to the instruction manual supplied by the voltage regulator manufacturer for specific safety procedures for bypass switching. Failure to comply will result in severe personal injury or death.

VR-T214.0

If any problems are encountered during the operational check, contact the Voltage Regulator Support group at (886)975-7347 (International calls at (262)896-2591 and e-mail at RES-VRsupport@Eaton.com).



Eaton
1000 Eaton Boulevard
Cleveland, OH 44122
United States
Eaton.com

Eaton's Power Systems Division
2300 Badger Drive
Waukesha, WI 53188
Eaton.com/cooperpowerseries

© 2016 Eaton
All Rights Reserved
Printed in USA
Publication No. MN225017EN/October
2016
(Supersedes S225704 January 2014)

Eaton is a registered trademark.

All trademarks are property
of their respective owners.

For Eaton's Cooper Power series CL7
control product information call
1-877-277-4636 or visit:
www.eaton.com/cooperpowerseries.