

VOLTMETER — INSTRUCTIONS

A voltmeter measures the voltage (pressure of electricity) between the two points where the leads are connected. Most vehicles will show between 13 and 15 volts while being operated above idle speed. Check your owners manual or dealer for a more exact normal voltage for your vehicle. A voltmeter is useful in that it can give a warning of many electrical problems and can show many problems faster than an ammeter.

PRECAUTIONS

1. Follow the instructions carefully for the sequence of nuts and washers on the connection posts of the voltmeter Diagram 1.
2. Disconnect the battery's ground cable before working on the voltmeter connections.

INSTALLATION

1. Disconnect the ground cable from the battery.
2. Connect a length of 18-gauge insulated copper wire to a good ground source. Be sure the grounding surface is a good ground source as not all metal surfaces inside the vehicle are well grounded. This wire should be long enough to reach the voltmeter's mounting location.
3. Connect another length of 18-gauge wire to a location on the fuse box where the wire will receive power whenever the ignition key is in the START, ON or ACCESSORY positions. This wire should also be long enough to reach the voltmeter.
4. After mounting the gauge, the wire from the

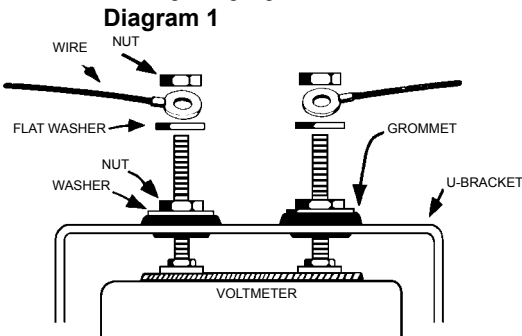

DO NOT LEAVE ANY HARDWARE
OUT OF THESE CONNECTIONS

ground source (Step 2) should be connected as shown in Diagram 1, to the voltmeter's connection post marked "-".

5. The wire from the fuse box (Step 3) should be connected as shown in Diagram 1, to the voltmeter's connection post marked "+".
6. Reconnect the battery ground cable. As you do, watch for sparks and check if the wiring you worked with is getting warm. If either condition is noted, IMMEDIATELY disconnect the battery ground cable and read the Troubleshooting section.

TROUBLESHOOTING

1. If, when you reconnected the battery ground cable, you noticed sparks or any of the wiring getting warm, check that all connections are properly located, and insulated from grounding.
2. If the reading on the gauge stays at the lowest marked voltage when the ignition is switched on, then try reversing the wires on the gauge's connection posts "+ and -".
3. If the gauge reads lower than you expect, check all connections, especially those to a ground source. A poor connection causes resistance which gives a false low reading.

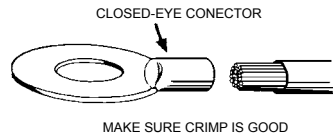

BOSCH

WATER/OIL TEMPERATURE GAUGE INSTRUCTIONS

Warning: If your car is microprocessor (computer) controlled or has an electric cooling fan, refer to the section in the installation instructions titled "Microprocessor Controlled Engines."

Temperature gauges measure the temperature of any liquid their sender tip is submerged in. An electrical temperature gauge is simpler and more versatile for installation than a mechanical gauge but is not quite as fast to respond to temperature changes.

PRECAUTIONS

1. A temperature gauge requires that its sender tip have a circulating flow around it to give an accurate reading. For this reason, a T-fitting cannot be used because it has no circulation therefore the original warning light sender cannot be operated off the same location. An additional location may be available on the cylinder head, intake manifold, or thermostat housing but caution should be used in that these locations may have different average temperatures than the original warning light sender location.
2. Do not over tighten the fittings or sender, particularly for mechanical gauges. The threads are designed to strip before the engine component can be damaged. The fittings use tapered self-sealing threads and do not require extreme force to seal properly.
3. Do not use sealing tapes or compounds on electrical senders as this will disturb their grounding connection to the engine resulting in false low readings.
4. Take caution when uncoiling and routing the mechanical gauge's capillary tubing that you do not bend it too sharply or flex it too often. Any break in the inner tube will make the gauge nonrepairable. A replacement service is available only at the factory service center.
5. Always install the adapter fitting into the engine first and then tighten the captive fitting (Diagram 1) on the capillary tube to avoid twisting the tubing.

6. Never install the captive fitting on the capillary tube directly into the engine without an adapter, as a proper seal will not be formed.

INSTALLATION

Note: If you are planning to use both an oil temperature gauge and an oil pressure gauge, some modifications may be necessary as there is only one available hole for both senders. Since the temperature gauge cannot use a T-fitting, we suggest that you install the oil temperature sender into the oil pressure warning light sender location in the engine block. Then obtain an adapter (which we do not manufacture) used for oil coolers which will give you an additional outlet for oil pressure.

FOR MECHANICAL GAUGES:

1. Drain the fluid level in the system to below the sender's mounting location which is normally the factory's warning light sender location.
2. Route the capillary tubing through the mounting

Diagram 1

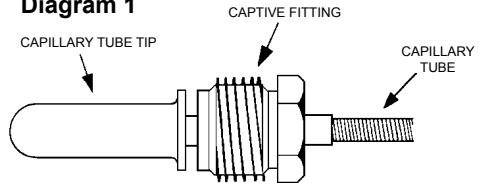

hole for the gauge and then through the firewall, protecting the tubing from rough edges. Form at least one 3" or larger loop of tubing as it comes through the firewall and route the remainder to the sender mounting locations.

- Remove the warning light sender and install the proper adapter fitting into the engine block. If the proper adapter fitting was not included with the gauge, obtain the CP7555 (NPT threads) adapter set.
- Insert the capillary tube tip into the adapter's hole and then tighten, with moderate pressure only, the captive fitting (Diagram 1) into the adapter. Do not over tighten. Sealing tape or compound may be used on either connection.
- Complete the mounting of the gauge.
- Refill the fluid level to its normal level.
- Start the engine and observe the fitting connections for leaks and the gauge for proper operation.
- Connect one end of another length of 18-gauge insulated copper wire to the center connection post, as shown in Diagram 2 and the other end of the wire to a good ground source.
- Connect a third length of 18-gauge insulated copper wire to the right connection post as shown in Diagram 2, and the other end of the wire should be connected to the fuse box where the wires will receive +12 volts of power whenever the ignition key is in a START, ON or ACCESSORY position.
- Refill the fluid level to its normal level.
- Start the engine and observe the fitting/sender connections for leaks and the gauge for proper operation.

FOR ELECTRICAL GAUGES:

- Drain the fluid level in the system to below the sender's mounting location, which is normally the factory's warning light sender location.
- Remove the warning light sender and insulate the end of the sender wire. Install the proper adapter fitting (not included) into the engine block, if needed. Obtain either the CP7553 (NPT threads) or CP7573 (metric threads) adapter set, if an adapter is needed.
- Install the gauge's sender into the warning light sender's mounting location in the engine block.
- Run a length of 18-gauge insulated copper wire from the gauge's mounting location to the sender's mounting location.
- Attach the 18-gauge wire onto the top of the gauge's sender.
- Facing the back of the gauge, the connection post on the right is for the +12-volt power, the center post is for the ground connection and the left post is for the sender connection. After you have mounted the gauge, connect the sender

TROUBLESHOOTING

If your electrical gauge reads lower than you would expect, check all electrical connections, particularly grounding connections. Any poor connection will increase electrical resistance resulting in a false low reading.

Diagram 2

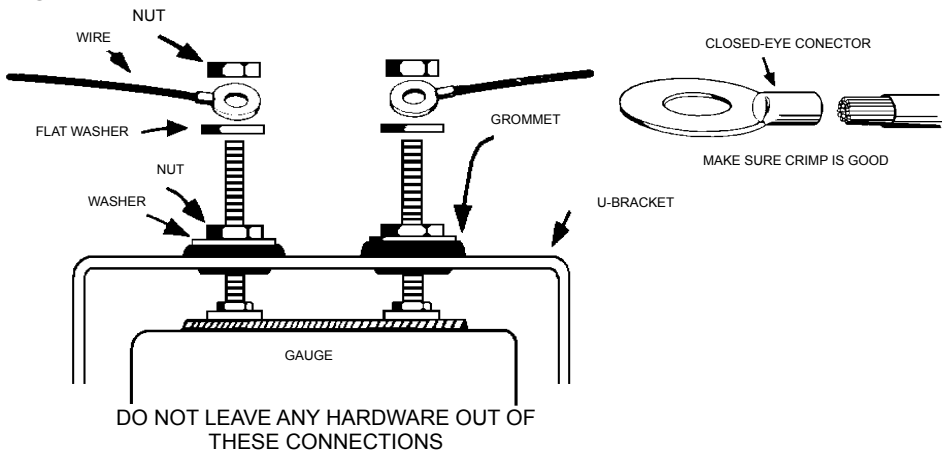

OIL PRESSURE GAUGE - INSTRUCTIONS

WARNING: If your car is microprocessor (computer) controlled or has an electric cooling fan refer to the section in the installation instructions titled MICROPROCESSOR CONTROLLED ENGINES.

Pressure gauges can measure the pressure present in a system utilizing air or liquids. An electrical pressure gauge is simpler and more versatile for installation than a mechanical gauge but is not quite as fast to respond to pressure changes. The factory warning light sender can be retained to operate the warning light with the use of a T-Fitting which is commonly available at auto parts stores and is manufactured by we.

PRECAUTIONS

1. Check the owner's or service manual, or your local dealer, to be sure that the normal pressure during cold-start and fully-warmed operation for your engine or air system are within the gauge range.
2. Be sure the tubing kit for the mechanical gauge is long enough for your application.
3. Follow the instructions carefully. A leak that goes unnoticed may lead to serious engine damage.
4. Do not use sealing tapes or compounds on electrical senders. This will disturb their grounding connection to the engine/system, resulting in false low readings.
5. Be careful not to crimp the tubing while unrolling it. Do not use any section of tubing with a crimp or kink in it. If the nylon tubing is a little awkward to use because of being rolled, heat it in boiling water and let the tubing cool while it is unrolled.

INSTALLATION

Note: If you are planning to install an oil temperature gauge as well as an oil pressure gauge, read the Note under INSTALLATION in TEMPERATURE-WATER/OIL INSTRUCTIONS.

For Mechanical Gauges:

1. If you are monitoring a fluid system, drain the fluid level to a level below the warning light sender location.

Diagram 1

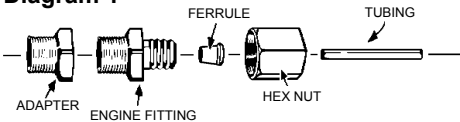

2. Remove the warning light sender from the engine and install the engine fitting in the same location. If an adapter is required, first install the adapter and then install the engine fitting.
3. Uncoil a few feet of tubing and slide the hex nut and ferrule over the end of the tubing as in Diagram 1. Insert the tubing into the engine fitting, and then tighten the hex nut into the engine fitting.

Diagram 2

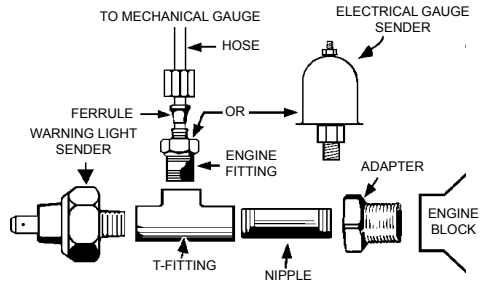

4. Optional T-Fitting (Diagram 2)- Install the nipple into the T-Fitting and tighten the end of the other nipple into the warning light sender location. Install an adapter fitting first if needed. In one of the two remaining openings in the T-Fitting, insert the engine fitting and then follow Step 3 to connect the pressure tubing. Insert the warning light sender into the remaining T-Fitting opening. Install an adapter fitting first, if needed (we do not produce metric fittings for the connection from a metric warning light sender to the T-Fitting).

Diagram 3

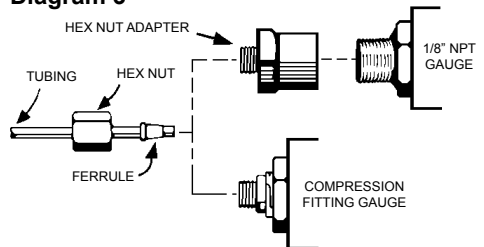

- On some models, the hex nut adapter (Diagram 3) is pre-installed on the back of the gauge. If not, install the hex nut adapter onto the gauge.
- Route the remaining tubing through the fire wall to the gauge mounting location. Leave at least one 3" or longer loop in the tubing before it enters the fire wall and protect the tubing from rough edges of the fire wall hole.
- Repeat Step 3 to attach the tubing to the gauge.
- Complete the mounting of the gauge.
- Refill the fluid level, if drained, to its normal level.
- Start the engine and observe the fitting connections for leaks and the gauge for proper operation.

For Electrical Gauges:

- If you are mounting a fluid system, drain the fluid level to a level below the warning light sender location.
- Remove the warning light sender from the engine and insulate the end of the sender wire if a T-Fitting is not being used. Install the gauge's sender in the same location in the engine block. If an adapter is required, first install the adapter and then the gauge's sender.
- Optional T-Fitting (Diagram 2) - Install the nipple into the T-Fitting and tighten the other end of the nipple into the warning light sender location in the engine block. Install an adapter fitting first if needed. In one of the two remaining openings in the T-Fitting, insert the gauge sender. Insert the warning light into the remaining T-Fitting opening. Install the adapter fitting first, if needed. (we do not produce metric fittings for the connection from a metric warning light sender to the T-Fitting).
- Run a length of 18-gauge insulated copper wire from the gauge's sender to the gauge's

mounting location.

- Connect the wire to the connection on top of the gauge sender.
- Facing the back of the gauge, the connection post on the right is for +12 volts power, the center post is for the ground connection and left post is for the sender connection. After you have mounted the gauge, connect the sender wire to the left connection post as shown in Diagram 4. Do not over tighten.
- Connect one end of another length of 18-gauge insulated copper wire to the center connection post, as shown in Diagram 4, and the other end of the wire to a good ground source.
- Connect a third length of 18-gauge insulated copper wire to the right connection post as shown in Diagram 4, and the other end of the wire should be connected to the fuse box where the wire will receive +12 volts of power whenever the ignition key is in the START, ON or ACCESSORY position.
- Refill the fluid level, if drained, to its normal level.
- Start the engine and observe the fitting connections for leaks and the gauge for proper operation.

TROUBLESHOOTING

If your electrical gauge reads lower than you would expect, check all electrical connections, particularly grounding connections. Any poor connection will increase resistance resulting in a false low reading.

Diagram 4

