

# AUTOMATION 2020

VOLUME 3

## Control Systems

- ▶ The Big Idea of Open Standard Control
- ▶ The Race to Build the Always Safe, Always Productive Plant
- ▶ Case Study: Machine Builder Adapts using PC-based Control
- ▶ Single-Pair Ethernet: The Infrastructure for IIoT



# Table of Contents

AUTOMATION 2020 VOL 3

Page 5

## Single-pair Ethernet: The Infrastructure for IIoT

by: Matthias Fritsche, Rainer Schmidt, and Yvan Engels, HARTING

Discover the history, technical details, and applications of SPE.

Page 17

## On Your Mark, Get Set, Go – A Race to Build the Smart and “Always Productive” Plant

by: Anand Vishnubhotla, Honeywell

Challenges and opportunities await those transforming their businesses and building safer and smarter process plants.

Page 25

## New Freedom in Engineering: The ctrlX AUTOMATION Platform

by: Steffen Winkler, Bosch Rexroth

If an industrial automation platform were reinvented by Google or Apple, it might have the integrated functions and flexible app technology of a smartphone.

Page 34

## Kit Encoders: New Technologies for a Dynamically Changing Market

by: Christian Fell, POSITAL

Understand the variety of component-level sensor devices built into servomotors and other machinery.

Page 44

## The Big Idea of Open Standard Control

by: Bill Lydon, Automation.com

Machine builders win as the foundations of the automation industry get reshaped.

Page 50

## Case Study: Machine Builder Conquers Adaptive Limitations with PC Control

from: Beckhoff Automation

Robotics, EtherCAT, and flexible PC-based automation combine to create complex and customized laser peening systems.

# Introduction

The foundations of the automation industry are being reshaped by a flood of new ideas, software, and products being driven by consumer electronics, the Internet of Things (IoT), and the unbundling of hardware and software. Machine builders in particular are finally starting to benefit from automation platforms that provide dramatically increased power at a significantly lower cost, coupled with faster, more flexible development options that streamline commissioning. In this edition of **AUTOMATION 2020**, you'll learn about the promise and reality of control systems that combine such new technologies with the robustness, security, and sophistication needed for industrial applications. Volume 3 also includes an in-depth look at single-pair Ethernet—the infrastructure for Industrial IoT—as well as component-level sensor technologies for servomotors and other machinery.

The **AUTOMATION 2020** ebook series from [Automation.com](https://www.automation.com) delivers sponsored and curated articles featuring best practices and cutting-edge insight from a variety of subject-matter experts. Future volumes of these single-topic compilations will cover IIoT and smart manufacturing, industrial cybersecurity, and more. [Subscribe online](#) to not miss a single issue.



**Honeywell**

**rexroth**  
A Bosch Company

**BECKHOFF**



**POSITAL**  
FRABA



# Many-core power, DIN rail form factor

Powerful Embedded PC series offers up to 12 CPU cores  
with advanced Intel® Xeon® D processors

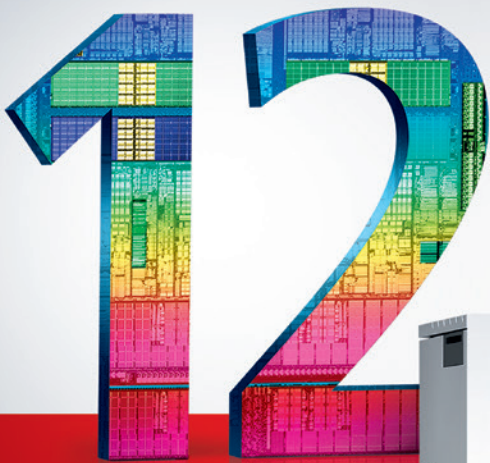

[www.beckhoff.us/Many-Core-CX](http://www.beckhoff.us/Many-Core-CX)

The Embedded PCs from the CX2000 series set new performance standards for DIN rail mounted controllers. With 4, 8 or up to 12 cores, task cycle times of 100  $\mu$ s per core and an extended operating temperature range of -25 °C to +50 °C, these compact Embedded PCs offer a significant performance boost. The result: minimal hardware footprint and the highest controller performance available on DIN rail – ideal for high-performance automation and motion control applications.

- CPU variants
  - CX2042: Intel® Xeon® D-1527 2.2 GHz, 4 cores
  - CX2062: Intel® Xeon® D-1548 2.0 GHz, 8 cores
  - CX2072: Intel® Xeon® D-1567 2.1 GHz, 12 cores
- Main memory: 8 GB DDR4 RAM up to max. 32 GB DDR4 RAM
- Graphic card: separate GPU, 2 GB GDDR5
- Interfaces: 2 x Gbit Ethernet, 4 x USB 3.0, 1 x DVI-I, 1 x multi-option
- I/O: modularly extendable with Beckhoff Bus Terminals and EtherCAT Terminals

New Automation Technology

**BECKHOFF**

# Single-Pair Ethernet: The Infrastructure for IIoT

Ethernet is the leading network protocol in LAN applications and is increasingly gaining ground in new areas. At the start of the Ethernet “era” in the early 1980s, coaxial cabling dominated (called thick Ethernet – yellow cable, thin, or cheap Ethernet). In the 1990s, the focus shifted to cabling solutions based on symmetric cabling (twisted pair) and fiber optics.

Initially, twisted-pair cabling relied on two-pair cables. This used a wire pair as a transmission and reception line (100Base-TX). This principle, limited to a transfer rate of 100 Mbit/s, is still the primary transfer principle in industry and automation systems technology today and is often achieved using star-quad cable designs. To achieve higher transfer rates of 1 Gbit/s and 10 Gbit/s, a transfer technique was selected that uses four symmetric pairs in connection with eight-pole plug connectors.

Discover  
the history,  
technical  
details, and  
applications  
of SPE

By Matthias Fritsche, Rainer Schmidt,  
and Yvan Engels, HARTING



Now, let's discuss the transfer of Ethernet with a single strand pair, a solution that runs contrary to the technical development of Ethernet and its associated cabling. This article deals with the background of single-pair Ethernet (SPE), including the technical details, the normative activities, and the applications. We consider the performance of new chipsets and discuss the classification of single-pair cabling regarding existing two- and four-pair versions and future cabling.

## Megatrends in information and communications technology

The development of new communication technologies and their associated cabling philosophies are influenced and driven by current information and communications technology (ICT) megatrends such as IoT, Industry 4.0 (I4.0), cloud computing, and smart technologies. This leads to new demand profiles regarding communications technology and the network infrastructure behind it, based on cables and connectors.

Demands for this new technology include high availability, quick access (including to distributed data), and fast transport of this data from A to B. Secure transfer of large datasets in different application areas including those needing determinism (real-time transfer, i.e., guaranteed data transfer within a defined time frame) is also critical.

Data transfer should remain cost efficient. For devices, cables, and connecting hardware, this means they must achieve higher performance, be smaller and stronger, and possess a high degree of modularity and compatibility (exchangeability and plug compatibility). These demands can only be fulfilled through innovation, i.e., game-

### Internet of Things

The term Internet of Things (IoT) describes the coming “technological intelligence” of things from computers and technological facilities to objects. It requires the unique identification of physical objects through system designations (MAC address, RFID, labeling, etc.), which allows these physical objects to be linked with a virtual representation (description/representation/admin shell, etc.).

Additional requirements include the ability of these objects to communicate with each other (exchange data), the development of technologies suitable for this, and the constant miniaturization of technical objects and their communication facilities. The visionary goal of IoT is to achieve artificial intelligence, that is, enabling devices to make decisions. This should occur independently of people using algorithms or special software.

changing technology developments of products with consistent international standardization.

Another trend in network technology and cabling is the increasing use of Ethernet protocols in new application areas. This includes many automation protocols and, increasingly, sensor/actuator applications. Numerous traffic and transport platforms, such as rail, tram, bus, ship, and aircraft, are fitting their fleets with Ethernet.

Whilst Ethernet has been successfully employed, particularly for passenger information systems and for WLAN services, for many years now in the methods of transport mentioned above, it remained more or less unused in the private car/truck market. The automobile industry has now recognized the advantages of Ethernet and started an initiative to develop Ethernet protocols for short-distance transmission routes in vehicles.

The solution is called single-pair Ethernet for transmission distances up to 15 m or 40 m. This Ethernet technology has since been published in the standards of IEEE 802.3bp 1000Base-T1 (gigabit Ethernet over single-pair balanced copper cabling) and 802.3bw 100Base-T1 (100 Mbit over single-pair balanced copper cabling).

To achieve simultaneous transmission of data and energy, power over data lines (PoDL) was also defined under IEEE 802.3 bu. (PoDL

### Industry 4.0

Industry 4.0 (I4.0) takes the same approach as IoT, but focuses strongly on processes for the industrial production of products. In this way, I4.0 is pushing the development of all known automation technology whilst creating novel forms of secure information exchange and networking. Highly developed sensor/actuator technology is crucial for I4.0. Therefore, I4.0 represents a certain subset of IoT but cannot be considered equal to IoT. I4.0 takes industrial production, from folding boxes to highly complex products, such as cars, to a new level. It forges new increases in efficiency and allows individual products (like custom products and niche products) to enjoy the advantages of mass production.

### Cloud computing

Cloud computing describes the provision of information technology (IT) services (storage space, user software, database access, or computation power) via the Internet. Physically, data centers provide these services, which are often linked virtually with each other (cloud).

Cloud computing is not only of existential importance for companies. Private users also make use of applications, such as Google, social networks, or cloud computing. IoT and I4.0 also rely on cloud computing.

allows the transmission of both power and data over the single twisted pair. This means an additional power source is not required.)

Based on these standards, chipsets, devices, cables, and connecting hardware are now being designed, developed, and produced for integration in private cars. Cabling for private cars focuses on a transmission distance of up to 15 m. It must be unshielded because of weight and spatial constraints.

Larger vehicles, such as trucks and buses, require longer transmission distances of up to 40 m and, because of the associated higher electromagnetic compatibility (EMC) requirements, need to be fully shielded. In fact, the latter single-pair shielded transmission distance also has other “nonautomotive” application groups and has piqued the interest of manufacturers. This is because shielded, single-pair Ethernet cabling offers all the features required to fulfill the megatrend described above. They are fast, space-saving, cheap, and simple to implement.

For this reason, industry is showing increasing interest in solutions with single-pair Ethernet. In fact, within building automation, developers are actively considering the distinct possibilities provided by integrating single-pair Ethernet within the hierarchy and structure of contemporary building cabling. Then there are also many other application areas, which present attractive opportunities for the development of single-pair Ethernet.

The interest in single-pair Ethernet also reflects a general trend in standardized network cabling—diversification of structured cabling for specific application areas. ISO/IEC JTC1 SC25 WG3 includes activities or projects that deal with the realization and implementation of the technical results of IEEE 802.3 within structured building cabling.

### Smart technologies

The term “smart technologies” describes technologies, devices, or procedures that use “clever” solutions. Classic examples include intuitive user interfaces on tablets or smartphones, but also the collection of weather information from sensors from different manufacturers that are distributed worldwide. This means that smart technologies can be compared with trends, such as increasingly integrated “intelligence,” miniaturization, simplification, and networking. IoT, I4.0, and cloud computing make use of smart technologies.



## Standards activities for single-pair transmission channels and components

What do the standards activities look like for single-pair Ethernet communication? First, standardization is a continuous, dynamic process, which develops and publishes new standards, revokes existing papers, or updates and launches new standards projects. Therefore, this article is just intended to be a snapshot of the state of standardization.

Standards activities in IEEE 802.3 define the Ethernet transmission protocol and define the minimal requirements for link segments (link segments are not identical but are similar to the transmission channel of cabling). ISO/IEC JTC 1/SC 25/WG 3 defines the required cabling and, in doing so, relies on the component standards for cables and plug connectors, which are given in the IEC standards groups.

It works in a similar way in TIA TR-42, where cabling standards were developed specifically for the U.S., Canada, and Mexico. TIA is more interested in keeping its own standards in line with the ISO/IEC ones—mostly. As already mentioned, the following IEEE 802.3 standards have already been published.

- ▶ IEEE 802.3bp 1000 BASE-T1 “Physical Layer Specifications and Management Parameters for 1 Gb/s Operation over a Single Twisted

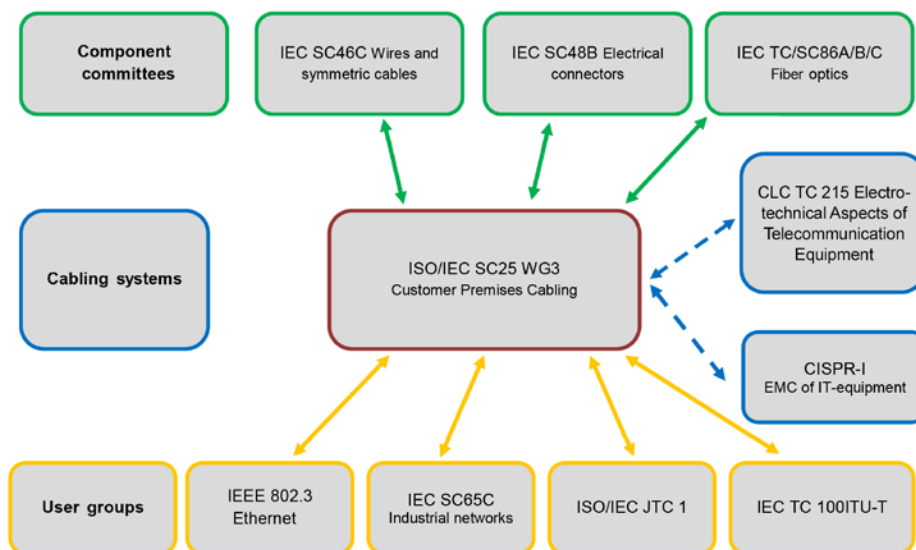

Coaction of standardization bodies for cabling.

Pair Copper Cable” defines single-pair Ethernet transmission via a 15-m UTP channel (Type A, unshielded) and a 40-m STP channel (Type B, shielded). Both channels are specified for a bandwidth of 600 MHz, may contain up to four connections, and guarantee a transmission capacity of 1 Gbit/s.

- ▶ IEEE 802.3bu “Physical Layer and Management Parameters for Power over Data Lines (PoDL) of Single Balanced Twisted-Pair Ethernet” is analogous to power over Ethernet (PoE) and also specifies the parallel provision of energy up to 50 W via single-pair Ethernet channels.

Therefore, a technical report was prepared under the title “ISO/IEC TR 11801 9906,” for one-pair channels up to 600 MHz, which describes shielded single-pair transmission channels. The target applications are “nonautomotive” segments or Industry 4.0, IIoT, and smart lighting in the style of IEEE 802.3bp. These transmission channels allow bidirectional transfer of 1 Gbit/s by using a balanced pair up to 40 m with simultaneous energy supply of end devices.

The transmission channels typically consist of a 36-m permanent link that incorporates up to four connections and two 2-m long patch cords.

As part of the restructuring and updating of the ISO/IEC 11801 standards series (as the third edition), the application-specific

Standardization design		
Information system		
Application-neutral communications cable system		
European standards series:	International standards series:	Description:
EN 50173-1	ISO/IEC 11801-1	General requirements
EN 50173-2	ISO/IEC 11801-2	Office cabling
EN 50173-3	ISO/IEC 11801-3	Industrial cabling
EN 50173-4	ISO/IEC 11801-4	Residential
EN 50173-5	ISO/IEC 11801-5	Data centers
EN 50173-6	ISO/IEC 11801-6	Distributed building services

Cabling design standards on the European and international levels scheduled for 2018/19.

parts where an addition with single-pair shielded balanced cabling is technically and economically feasible will also be determined. Initial consideration suggests this is so for ISO/IEC 11801-3 (industrial applications) and ISO/IEC 11801-6 (building automation).

The cabling specifications (see ISO/IEC 11801) allow the requirements for the components, cables, and connectors to be derived. This is performed for cables in the IEC SC46C standards committee and for connectors.

### **IEC 61156-xx series**

The IEC 61156-xx series “Cables for 1 Gbs over one pair” international standards titles describe cables that are suitable for transferring 1 Gbit/s over a balanced pair. Application areas include the office, the home, and industry.

The use of four-pair data cables, which are capable of operating four single-pair transmission channels, should also be possible. This feature is also known as “cable sharing.” The transmission parameters should be defined for a frequency of up to 600 MHz, but consider especially the PSNEXT of the transmission channel.

### **IEC 63171-6 (formerly IEC 61076-3-125)**

The IEC 63171-6 standard, “Connectors for electronic equipment – Product requirements – Detail specification for two-way, free, and fixed connectors for data transmission up to 600 MHz with current carrying capacity,” was formerly IEC 61076-3-125. Following the application areas and performance of the single-pair cables, the two-pole connectors are being standardized up to min 600 MHz. Standardization of the connector means that the mated interface, including the mechanical locking mechanism, will be fully defined. Defining the interface ensures plug compatibility and guarantees that products from different manufacturers can be used. It is expected that various designs of single-pair connectors will then be available in safety class IP20 to IP65/67.

## Products for single-pair balanced transmission channels

The theoretical basis for designing a 40-m channel with single-pair cabling has already been worked out. This means that the interested manufacturers of electronics and cabling have all the necessary information on the development and design of chipsets, cables, and connectors at their disposal.

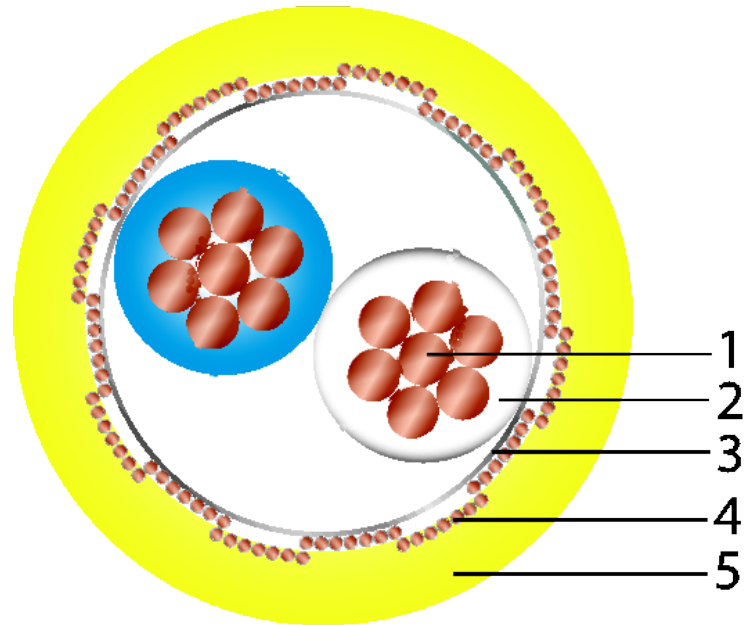

Cross section of a SPE cable.

1. Conductor	uncoated Cu (stranded), AWG26/7
2. Isolation	cell-PP, wire $\varnothing$ : NW 1.25 mm
Stranding element	Pair
3. Pair screen	Alu-coated polyester film, metal-side external (PiMF)
4. Overall screen	tinned Cu-meshing, optical covering approx. 90%
5. Cable jacket	halogen, flame-resistant compound

The first chipsets are already available on the market. However, a range of new products, which offer optimal support for the individual applications, are still expected. Devices fitted with “single-pair Ethernet” are expected within one to two years. There are basically two ways to transmit Ethernet according to 1000Base T1 over a single-pair cabling channel.

On the one hand, this protocol can be transferred using existing four-pair cabling according to category 7/transmission class F (specified up to 600 MHz) or according to category 7A/transmission class FA (specified up to 1000 MHz) according to the relevant qualification and with consideration of the length restriction of 40 m. This opens up the option of “cable sharing.” Cable sharing allows several single-pair Ethernet services to be transferred using a four-pair cable.

New single-pair cable and connector products have been created to serve new single-pair cabling structures on the basis of single-pair Ethernet. Important points for the design of the cabling components include:

- ▶ Impedance of 100  $\Omega$ , bandwidth of 600 MHz, and the associated fixed parameters, such as insertion loss, return loss, and alien cross-talk
- ▶ Complete shielding to ensure transmission quality under extreme EMC conditions
- ▶ Single-pair cable with the smallest possible outer diameter (space and weight savings) for fixed and flexible installation
- ▶ Two-pole plug connectors in the smallest possible design form for use in IP20 and IP65/67 environments—mutually compatible plug interfaces.

## The outlook for SPE

The increasing network requirements driven by the demands of I4.0 and IoT rely on innovative and application-specific solutions. Single-pair Ethernet offers the ideal solution for cable-based communications infrastructure. Particularly for application areas in industry and building management,

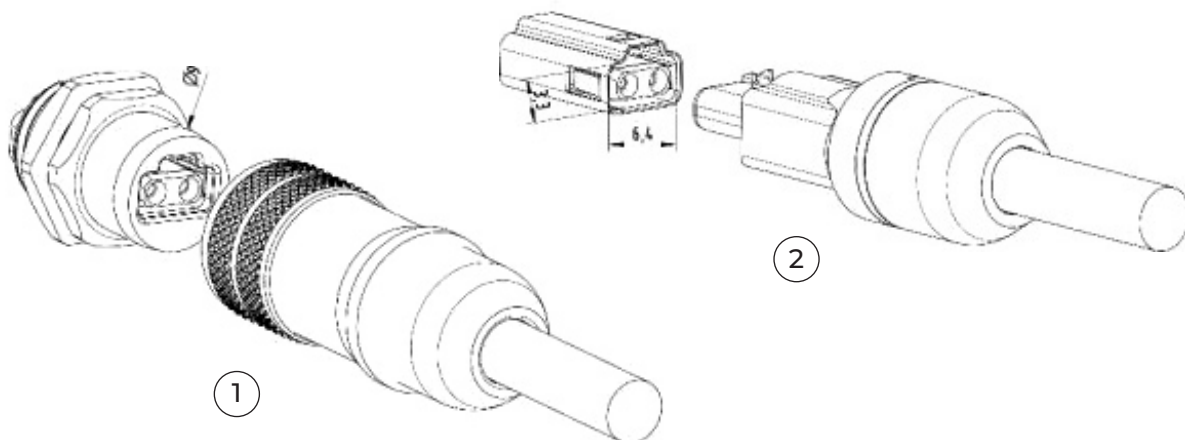

T1 connector design for SPE: (1) IP65/67 Single Pair Ethernet Plug-Socket with Push Pull Locking and (2) IP20 Single Pair Ethernet Plug-Socket. Both support 600-MHz bandwidth, fully screened design, and a minimum transmission rate of 1 Gbit/s.

this represents a smart addition to the communications landscape, which combine gigabit Ethernet performance, transmission reliability, optimal handling, and remote powering, as well as space and weight savings.

The normative basics have already been defined in IEEE 802.3 standards for applications within the automotive and nonautomotive sectors. IEEE 802.3 added the IEC 63171-6 connector standard to its documents. For the respective nonautomotive applications, the planning orientation incorporated within the international standards of ISO/IEC and IEC and TIA are used.

●●●●● **SPE allows Ethernet** to penetrate further into the field level and enormously reduces times for parameterization, initialization, and programming.

Both standardization bodies for cabling, ISO/IEC SC 25 and TIA TRE-42, give an explicit statement to use connectivity according IEC 63171-6 and cables according IEC 61156-11/12/13/14 to support industrial applications. The compact design of the device connectivity and the Ethernet compatibility according to IEEE 802.3 offer device development, e.g., within automation and sensor and actuator production, a networking concept that represents a simple change from bus to Ethernet technology. This allows Ethernet to penetrate further into the field level; enormously reduces times for parameterization, initialization, and programming; and expands the range of functions of devices.

Single-pair cabling saves space, installation time, and costs. At the same time, new applications are tapped, which were previously not open for cable-based infrastructure. After the Internet and Ethernet have connected people, computers, and machines both in terms of space and time, this is now also happening with objects and things. The backbone of this new technology is provided by, amongst others, single-pair balanced copper cabling. With this the connection between single-pair Ethernet technology and megatrends is more prevalent within the megatrends of IIoT and I4.0 than in cloud computing and big data.

Single-pair Ethernet represents an important technological progression, but is still only an addition to existing Ethernet technologies that use multipair copper cables or fiber optics. It will not replace them.

Single-pair Ethernet cabling opens up new application areas, e.g., in industry, sensor/actuator networks, smart buildings, and farming, and represents the future of Ethernet cabling. Therefore, single-pair Ethernet particularly supports trends such as IIoT and I4.0.

#### ABOUT THE AUTHORS



**Dipl. Ing. Matthias Fritsche** is the product manager, device connectivity, at HARTING Electronics GmbH.



**Dipl. Ing. Rainer Schmidt** is the business development manager at HARTING Electronics GmbH.



**Dipl. Ing. Yvan Engels** works in strategic market development/standardization at BU Datacom, LEONI Kerpen GmbH.

### Single-Pair Ethernet Partner Network

The [SPE Industrial Partner Network](#) is an equal association of companies focused on advancing and promoting the Single Pair Ethernet technology. The group believes single-pair Ethernet is the infrastructure basis that makes industrial digitalization, IIoT and Industry 4.0 possible. This is a strong partnership of industry leaders, who are united in their support of the T1 Industrial interface according to IEC 63171-6 as a uniform Media Dependent Interface (MDI) as defined by ISO/IEC JTC 1/SC 25/WG 3 and TIA42 in 2018.

The SPE Industrial Partner Network is based in Rahden, Westphalia, Germany.

The group supports building a strong SPE ecosystem and is committed to providing users with valuable information. The combining of the competencies of the individual companies is intended to give users the security they need to invest in this technology. Founding members are HARTING, Leoni, Murrelektronik, Würth Elektronik, TE Connectivity, Softing, HRS Hirose Electric Co. LTD. First additional members: DEHN, Molex, Amphenol, Helukabel, igus, ZAHOLONG, ESCHA, Perinet, Lutze.

From ["Single Pair Ethernet Industrial Automation Joins the IoT Revolution"](#) by Bill Lydon, *Automation.com Contributing Editor*

# Ever Wish Your Temperature Transmitters Could Talk?



RTD and Thermocouple sensor failure can be costly for any process or operation. Wouldn't it be great if your temperature transmitter gave you early warning of impending sensor failure? Moore Industries smart HART dual input temperature transmitters do just that with built-in features like Sensor Drift Detection and Sensor Corrosion Detection that alert you when your sensors are on the path to failure.

Bring predictive failure analysis right to the field with Moore Industries latest smart HART temperature transmitters.

Learn more about the Moore Industries Smart HART Dual Input Temperature Transmitters [THZ3 Temperature Transmitter](#), [TDZ3 Field Mount Temperature Transmitter with Display](#) and [STZ Functional Safety Temperature Transmitter](#)  
Or Call Us at 800-999-2900 or 818-894-7111 [www.miinet.com](http://www.miinet.com)





# On Your Mark, Get Set, Go – A Race to Build the Smart and “Always Productive” Plant

By Anand Vishnubhotla, Honeywell

Challenges and opportunities await those transforming their businesses and building smarter and safer process plants

Estimates vary, but the rough consensus is that approximately 75 billion devices will be connected worldwide by 2025. This is a five-fold increase over a 10-year period. With the next generation of connected infrastructure being rolled out with 5G, the trend is only expected to accelerate over the coming years. The accelerated adoption of cloud technology implies a reduction in the costs of computing power and storage for end users—leading to more adoption.

In the real world, these rapid advances in digital technologies, along with their increasing adoption, translate to an ever-growing connectivity between the physical assets and the digital world. For the process industry, these advancements in technology provide tremendous

opportunities to digitally transform—by creating smarter plants to unleash the next levels of business outcomes.

The benefits of a Smart Plant include better productivity, safer and more reliable operations, the ability to better respond to market dynamics, and reduced costs. Yet several challenges still exist in realizing this vision. The focus of this article is to discuss the challenges and opportunities in building Smart Plants.

## “Five-star” Smart Plant

To be characterized as a Smart Plant, here are some basic tenets:

1. All data is digital:
  - a. Data from all physical and digital assets is available, and digitized.
  - b. Smart sensors and equivalent technologies are widespread.
  - c. Mobile technologies are deployed to address any noninstrumented data.
2. Process digitalization:
  - a. Work processes are optimized and agile with minimal human intervention.
  - b. Work processes are integrated across the whole value chain—from suppliers to customers.
3. Intelligence augmentation:
  - a. Analytics are applied to the data using the right methods and are focused on moving from reactive to predictive and prescriptive.
  - b. Human knowledge is augmented by digital twin models. [Digital twins](#) are employed for decision making and what-if analysis. There is a dynamic knowledge base with coded business rules and an ability to self-learn through machine learning and artificial intelligence.



4. Insights delivered:
  - a. Insights are provided in near real time.
  - b. Insights are not constrained to applications, but distributed via multiple modes, including mobile. The right visualization and analytics tools are implemented so that users get the right information at the right time with the right context.
5. Cybersecure: Operations are highly resilient and cybersecure.

## Challenges to realize a Smart Plant

Although the Smart Plant benefit areas may be understood by an organization, there are certain structural challenges the process industry still faces:

1. Technology soup: There are a plethora of digital technologies, which can be overwhelming, cause confusion, and create a vicious cycle of chasing technology trends. There are several technologies that are maturing. These include, but are not limited to, cloud computing, virtualization, robotics, drones, intelligent wearables, mobility, 3D printing, augmented reality/virtual reality, big data analytics, digital twins, cognitive, machine learning, and artificial intelligence (AI), among others. The challenge is in finding a fit that best serves an organizational need, and that is also sustainable.
2. Cultural and organizational readiness and change management: Significant skills gaps still exist in the workforce to productively select, implement, and maintain these new technologies. In addition, the new workforce coming up has different expectations about working and does not have the same domain knowledge as retiring experienced staff.
3. Addressing risk:
  - a. Cyberthreats are a risk and prevent companies from adopting some of the newer technologies.
  - b. Another risk that prevents adoption is the fear of jobs being replaced with technology.
  - c. Lack of compelling use cases that can scale quickly can prevent adoption.

## Seven fundamentals for realizing Smart Plant vision

Several organizations have embarked on the digital transformation journey to build Smart Plants. While the approaches vary depending on the digital maturity and business imperatives of the organization, a few common elements can be found in successful companies. They have:

1. Clear strategy: [Digital transformation](#) is a key boardroom strategy discussion and is considered a clear competitive differentiator. Strategy is developed for existing (brownfield) and new (greenfield) facilities. Strategy encompasses all aspects of an asset life cycle—from design to the operations phase.
2. Strong technology roadmap: Moving from a point solution approach to a platform approach is a key mantra driving these organizations. Data is viewed as a significant asset. Cybersecurity is a key risk management at the information technology (IT) and operational technology (OT) layer.
3. Collaborative work processes: Work processes are designed to eliminate silos and allow transparent data and information exchange. Collaboration is kept as a central design principle.
4. Governance framework: A governance framework to ensure the right technology, organizational design, and work processes is established.



5. Emphasis on partnerships: Strong partnerships with suppliers and end customers create an end-to-end ecosystem.
6. Culture: A collaborative innovation culture is consciously developed and nurtured. Experimentation is encouraged. Think big, start small, and scale fast.
7. Focus on digital talent development and change management: Leadership provides significant emphasis on organizational design and workforce competency. In a Smart Plant, the end users are educated and capable of gaining value from the technology and analytics insights. These emancipated users ensure the realization of anticipated outcomes—from better productivity and safer and more reliable operations to the ability to better respond to market dynamics and reduce costs.

## Smart Plants integrate intelligence

Brownfield operators face unique challenges and opportunities in the move toward a smart plant. Newer digital technologies should complement existing technology investments where possible to avoid unwarranted disruption.

Industry has adopted various software applications to address specific work processes. They range from an organization's supply chain management to plant operations. IT integration projects are typically implemented to ensure data and work processes are integrated.

The amount of data is ever increasing, and getting the right insights to the right users at the right time with the right context is still a challenge. Users must still navigate multiple applications and data sources.

A common solution to this problem is to provide dashboards and reports that collate metrics and key performance indicators (KPIs) from disparate systems. Although this is a step in the right direction, it does not solve the problem entirely. In addition to actionable KPIs, a clear set of intelligent recommendations is of higher value.

To achieve the vision of smart plants, one key improvement organizations must make is to move from data integration to *intelligence integration*. What exactly is intelligence integration? Let's use an example to understand this.

Consider a typical process unit. On this unit, several applications, such as advanced process control, asset monitoring, production management, operations monitoring, and alarm management systems, either control or monitor the unit's performance, reliability, and so on. There are several models developed within these applications—ranging from first principles, heuristics, and empirical models to machine learning models. Each of these models generates certain insights and recommendations for the user. But they are all working in isolation. Many times, one root cause creates symptoms and anomalies in various parameters, which these applications capture individually.

What if there is a platform where these data and models can be integrated, provide the user with a prioritized recommendation, and point to the root cause rather than symptoms? Providing a prediction of the future state can also help avoid issues.

Detection of certain anomalies in the process industry is especially challenging. The number of related incidents tends to be few, so using traditional data analytics poses a challenge. Also, the time-varying nature of the process and disturbances is another challenge to overcome. A combination of first principles with data-driven models that is complemented with operational knowledge/heuristics can be a better approach to overcoming these challenges.

In the future, more and more such models will be developed, and intelligence integration between these models will enable smart plants. Intelligence integration then morphs into an intelligent *digital assistant* to the user.

## Smart and productive plant

While all of the above is true, it is also true that every plant today is encountering a new normal—a normal that includes a partial or fully

remote workforce, distance learning, training and onboarding, remote asset monitoring, and the use of data even more than before to predict, propose, and prescribe. In a perfect world, a plant will have solutions to each of these unique challenges faced by operators the world over. These solutions will power and protect your workforce, ensure asset uptime, and most of all maintain productivity.

This is the new smart and always productive plant.

The race to build such plants is on, and effective and efficient use of data is central to success. Data is clearly an asset that needs to be used to develop intelligent models that interact with each other to provide greater value. While the accelerated availability and capabilities of digital technologies give us better techniques to harness data, other organizational and human element challenges remain to realize the smart plant vision. Organizations that can develop a holistic digital strategy, including developing digital talent, digitalizing work processes, and digitizing activities, will clearly have a leading competitive advantage.

---

#### ABOUT THE AUTHOR



**Anand Vishnubhotla** is the general manager, Asia Pacific, for Honeywell Connected. With more than 23 years of industry experience, his current responsibilities include setting strategic vision for the region and leading cross-functional teams within Honeywell to execute the strategy and annual operating plans. At Honeywell, Vishnubhotla has partnered with large clients in developing and deploying digital transformation, information integration, performance management, and collaboration programs.

Vishnubhotla completed his chemical engineering degree from the Indian Institute of Technology, Chennai, and has master's degree in computer process control from University of Alberta, Canada. He likes to play bridge and chess in his spare time. He also enjoys watching and playing cricket.

rexroth

ctrlX CORE

# THE SMARTPHONE OF INDUSTRIAL AUTOMATION.

With ctrlX AUTOMATION, your Factory of the Future becomes a reality ... Now. Next. Beyond. Bosch Rexroth's new automation platform allows manufacturers to add new machine functions via app, making automation as easy as using your smartphone.

Learn more at [www.ctrlx-automation.com](http://www.ctrlx-automation.com)

**ctrlX**  
AUTOMATION

**rexroth**  
A Bosch Company

BR10363/06.2020

© 2020 Bosch Rexroth Corporation. All rights reserved.



# New Freedom in Engineering: The ctrlX AUTOMATION Platform

If an industrial automation platform were reinvented by Google or Apple, it might have the integrated functions and flexible app technology of a smartphone

By Steffen Winkler,  
Bosch Rexroth

Nowadays, mechanical engineering means one thing: software development. In some machines, software accounts for more than 50 percent of value creation. Software determines the flexibility, connectivity, availability, and ease of operation of machines and systems. Automation technology must fit into information technology with as little effort as possible.

This is much easier if automation systems use the same communication standards and programming environments as the information technology (IT) world. This is why Bosch Rexroth has developed a new automation platform that combines automation, information technology, and the Internet of Things in a completely open system.

ctrlX AUTOMATION is based on an entirely new, open software architecture with app technology. A central result is that the engineering outlay for new machines is reduced by between 30 and 50 percent.

For a long time, automation-specific approaches and programs were adequate in mechanical engineering. As a result of connectivity with other machines and IT, more and more tasks outside the actual motion sequences must now be performed. For example, robotics and handling are key disciplines in the manufacturing industry as a way of optimizing recurrent work processes, conserving resources, and increasing reproducibility. However, they are the tasks that are most difficult to standardize in automation.

It is often the case that Cartesian systems and delta or SCARA robots must be adapted individually to the particular work pieces and processes. This ties up considerable engineering resources required elsewhere. The lack of specialists in the area of programmable logic controller (PLC) and G-Code programming further exacerbates the situation.

## **Automation and ecosystem according to the smartphone model**

When Bosch Rexroth engineers started developing the system, they imagined what automation would be like if it were reinvented by Google, Apple, or some other digital company. Because young specialists and developers are socialized with the Internet and smartphones, the automation model became the smartphone, highly integrated functions and flexible app technology for personalizing devices.

Bosch Rexroth relies on an open software architecture with flexible app technology and the ability to work in a wide range of IT programming languages. Accordingly, ctrlX AUTOMATION is based on a new software and engineering approach and means the end of proprietary structures and systems. The automation platform includes all necessary software and hardware components for complete system solutions: high-performance control systems, compact drives, safety,

I/O modules, and HMIs. The software flexibly takes over all tasks from simple handling applications to high-performance motion control. The system hardware and software are highly scalable.

To allow a significantly high degree of individualization, ctrlX AUTOMATION was developed as an open platform. This results in a new ecosystem for industrial applications. Software developers can now develop and make available industrial applications in all popular programming languages—quickly, easily, and flexibly. Completely new degrees of freedom arise, making it possible to produce and individually combine functions in virtually any programming language while protecting know-how.

### Three pillars for sound foundations

The ctrlX CORE control hardware forms the basis for ctrlX AUTOMATION's broad range of applications. A new generation of multicore processors provides sufficient computing power for all automation tasks—from PLC applications and motion control to computer numerical control (CNC) and robotics.

These high-performance CPUs can be integrated into embedded PCs (ctrlX CORE), into industrial PCs (ctrlX IPC), or directly into drives (ctrlX DRIVE). At the same time, there is ample performance to meet IT or Internet of Things (IoT) requirements when it comes to such a control system—requirements that are growing as a result of increasing digitalization and automation.

The ctrlX DRIVE system, with an integrated control system, opens up new degrees of freedom for innovative solutions. It is regarded

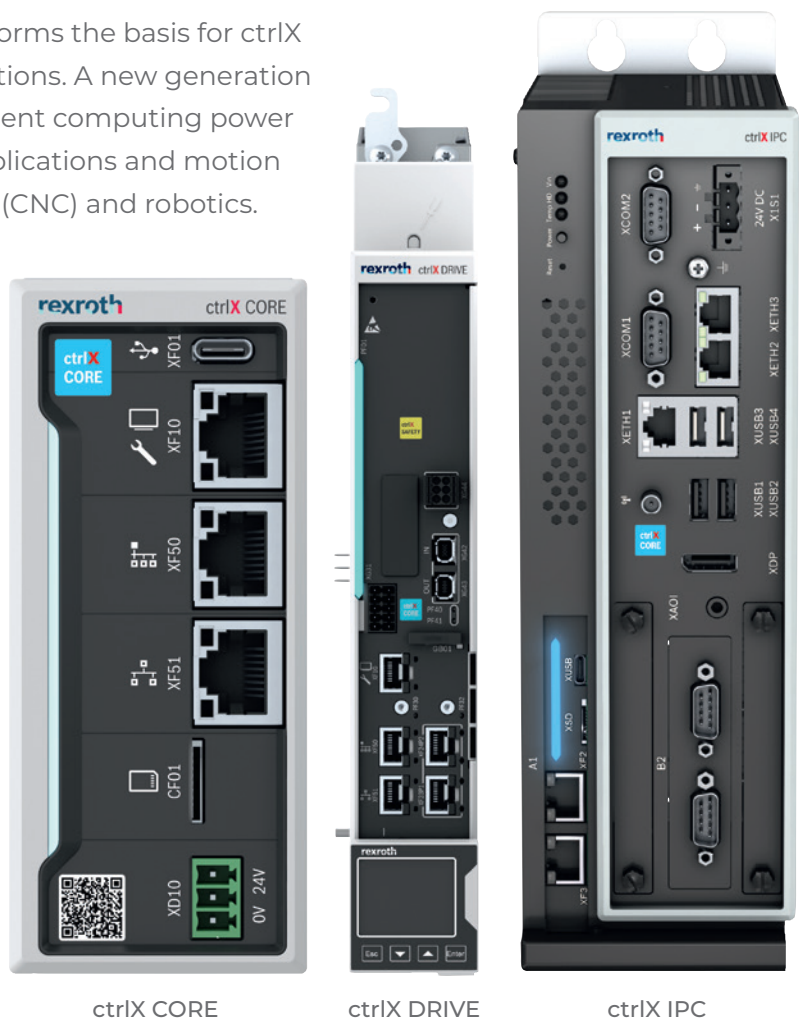

as the world's most compact modular drive system and represents a new generation of servo drives. The drive combines optimal dynamics with maximum precision of position, speed, and torque values. Not only does it have space-saving dimensions and maximum scalability, it also boasts advantages such as virtually unlimited combination options for users, sophisticated engineering tools, and high energy efficiency.

ctrlX DRIVE responds to the ongoing automation challenge of making smaller and smaller machines and control cabinets. The system is up to 50 percent more compact than the previous range and competitors' products. The integrated DC-bus connector technology reduces additional components and allows energy balancing via the DC bus. This optimizes power consumption and reduces power loss. With the end-to-end supply unit with single and dual-axis converters as well as power and regenerative supply units, users can combine any configurations. The ctrlX CORE control system can also be integrated with no need for additional space and used as a fully fledged automation solution.

In the fully configured standard drive, the STO safety function is a standard feature. The configurable ctrlX DRIVE<sup>plus</sup> also allows the use of additional cards for SafeMotion, multi-encoders, and I/O extensions.

Demanding process control systems often require large power reserves, which the PC-based ctrlX IPC automation solution provides—flexibility and scalability. The modular ctrlX CORE control platform can be integrated into the open ctrlX IPC portfolio via the PCIe interface. This means that the system can be extended by adding standard components or open source software. Numerous interfaces are available for communication.

ctrlX IPC forms the ideal interface between the field level and cloud and ensures the reliable and secure transmission of large quantities of data. The ctrlX CORE CPU is thus suitable for PC-based automation or edge solutions.

## Maximum independence when programming

Because ctrlX AUTOMATION requires no special PC software, it can be commissioned and learned with ease. Thanks to the web-based system,

users are guided logically through the basic configuration on HTML pages.

They can work with the familiar automation languages in accordance with IEC 61131 or G-Code to create PLCopen processes in an efficient manner. However, more and more young specialists are not trained in these automation programming languages. In light of this, Bosch Rexroth allows individual functions to be created in programming languages like JavaScript, Python, low-code programming languages, C languages, or the open source software Node-RED while protecting know-how in the process.

The app technology in ctrlX WORKS is a key part of ctrlX AUTOMATION. Standard functions, such as a data gateway to production planning systems or the IT connection, firewall, VPN client, or OPC UA, are available as ready-to-use apps on the control system and do not need to be programmed separately. Developers can select the required apps from the ctrlX WORKS software toolbox or use any open source software.

### ctrlX WORKS - The software and engineering toolbox

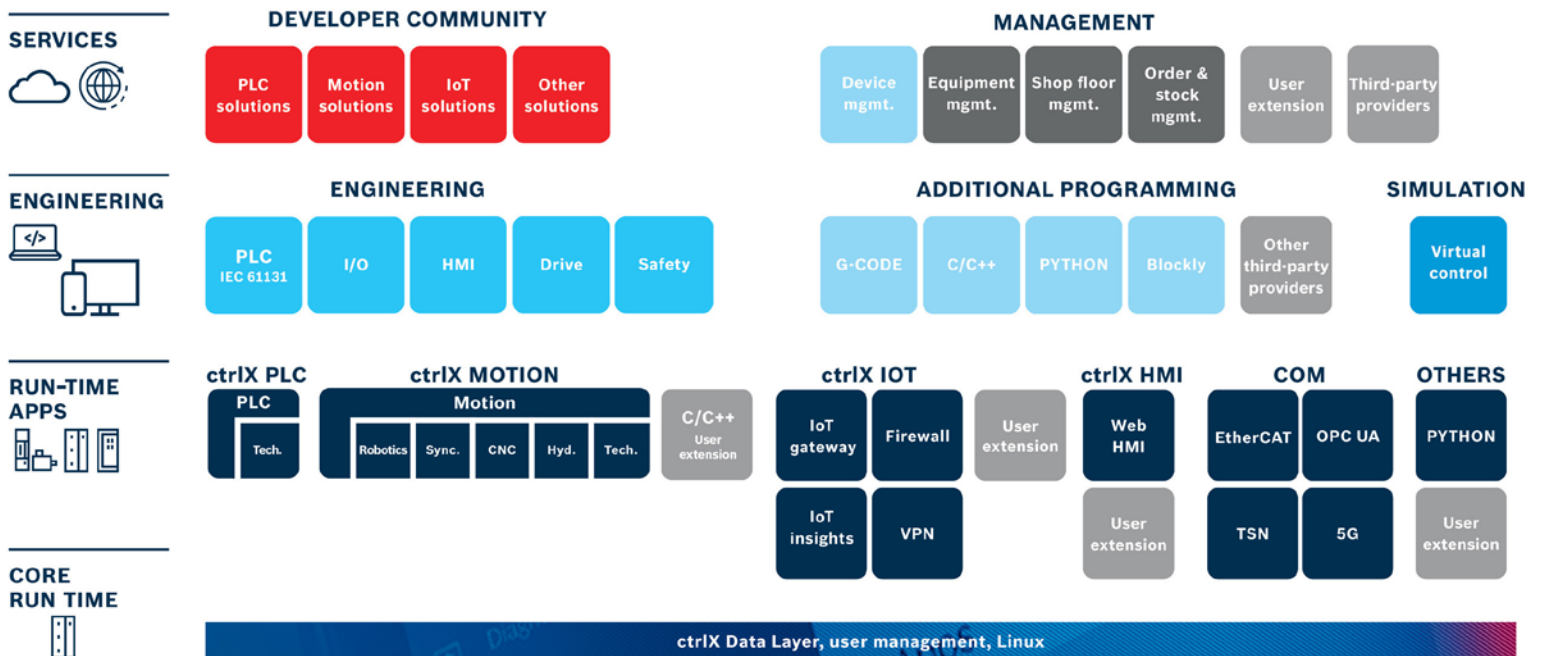

They can also program applications themselves or download third-party apps, e.g., from the GitHub development platform. With more than 10 million registered users, GitHub is an established global developer community. It offers machine manufacturers and end users access to a virtually unlimited library of written functions, e.g., for handling and robotics. With Git—the basic technology for version management—Bosch Rexroth also offers a version control facility and collaborative engineering.

Bosch Rexroth also provides numerous predefined functions for specific requirements. These include features that improve the productivity of handling systems and robots.

With ctrlIX CORE<sup>virtual</sup>, ctrlIX WORKS is available in a completely virtual form so that programming can be carried out even without hardware. As a result, users can develop and test new handling systems without blocking the machines and stations to be automated. With the new possibilities, users reduce their engineering outlay considerably and can set themselves apart from competitors with functions they have developed themselves.

## Central access to real-time and non-real-time data

ctrlIX AUTOMATION is based on the Linux real-time operating system, probably the most stable and secure operating system of its kind. Because of the operating system's container technology, programmers can reproduce all functions and applications with separate apps and combine them as required.

The ctrlIX Data Layer is an important architectural element. It ensures central, authorized access to all real-time and non-real-time data for the installed apps. Data generated by an app can be used by other apps as well. As the central nervous system, the ctrlIX Data Layer receives and distributes all data and values and gives them clear addresses.

Measurements show that up to 8 million accesses per second are possible. The automation platform also generates a real-time process

image and thus puts in place everything needed for machine learning applications, for example.

The new control generation is thus completely different from previous industrial control systems. After all, users never had access to core functions, and they have to execute applications on additional hardware either individually or subsequently. At the same time, data is stored at different locations and needs to be configured in order to be exchanged—a time-consuming process. This increases complexity when it comes to interfaces and data exchange and significantly increases the engineering outlay.

With the ctrlX Data Layer, it is immaterial whether applications are installed as run-time apps on a ctrlX CORE or are executed as engineering apps and services on a PC, smart device, or in the cloud.

## **Open communication thanks to connectivity**

ctrlX AUTOMATION is currently the most connectible, future-proof system available on the market. It takes care of all automation with absolute openness.

In field communication, Bosch Rexroth relies on established standards with ctrlX AUTOMATION. The control system master interfaces support primarily EtherCAT and possibly Profinet, Ethernet/IP, and Sercos. Using digital nameplates, the intelligent automation components and peripheral devices identify themselves automatically to the control system. This significantly reduces the commissioning outlay.

For communication with IT and the IoT, the new control systems also have a wide range of installed protocols and standards. The platform supports more than 30 standards and protocols for data exchange with IT systems. ctrlX AUTOMATION is also ready for future communication standards such as TSN and 5G.

## **Integrated norm-compliant safety technology**

Safety too is a key aspect with ctrlX AUTOMATION. The integrated ctrlX SAFETY technology combines safe logic and motion and simplifies

the implementation of norm-compliant machine safety. Norm-compliant safety technology is standard for machine manufacturers. With ctrlX SAFETY, companies can stand out from the competition in this area too. After all, a safety reaction that is ten times quicker than that with conventional fieldbuses is possible. Developers can set machine movements much more dynamically and with greater safety—thus increasing productivity.

## Conclusion

ctrlX AUTOMATION reduces the engineering outlay and the space required for machine manufacturers and integrators by between 30 and 50 percent—and increases productivity by up to 10 percent. With the automation platform from Bosch Rexroth, users can put individual solutions into operation much more quickly and program and provide functions easily and flexibly in any language. This reduces outlay and conserves resources.

---

### ABOUT THE AUTHOR



**Steffen Winkler** is the CSO, Automation and Electrification solutions, at Bosch Rexroth.



# Universal Industrial Gateway

72 Protocol Combinations  
All in One Gateway!

EtherNet/IP  
EtherNet/IP-PCCC  
Modbus TCP  
Modbus RTU  
Modbus ASCII  
DF1-PCCC  
DF1-CIP  
PPI  
S7comm (ISOTCP)  
HostLink  
CCM  
DirectNET



Easy Way to Gateway

No Programming Software  
No I/O Tree Changes  
No Ladder Logic to Program

[Click to Learn More](#)

What Customers Are Saying:

*"Exceptionally Easy and Friendly Interface"*

*"Fully Setup in 1-Hour and Moving Over 1,500 Tags!"*

*"A Flexible Solution for Our Factory Upgrades"*

# Kit Encoders: New Technologies for a Dynamically Changing Market

By Christian Fell, POSITAL

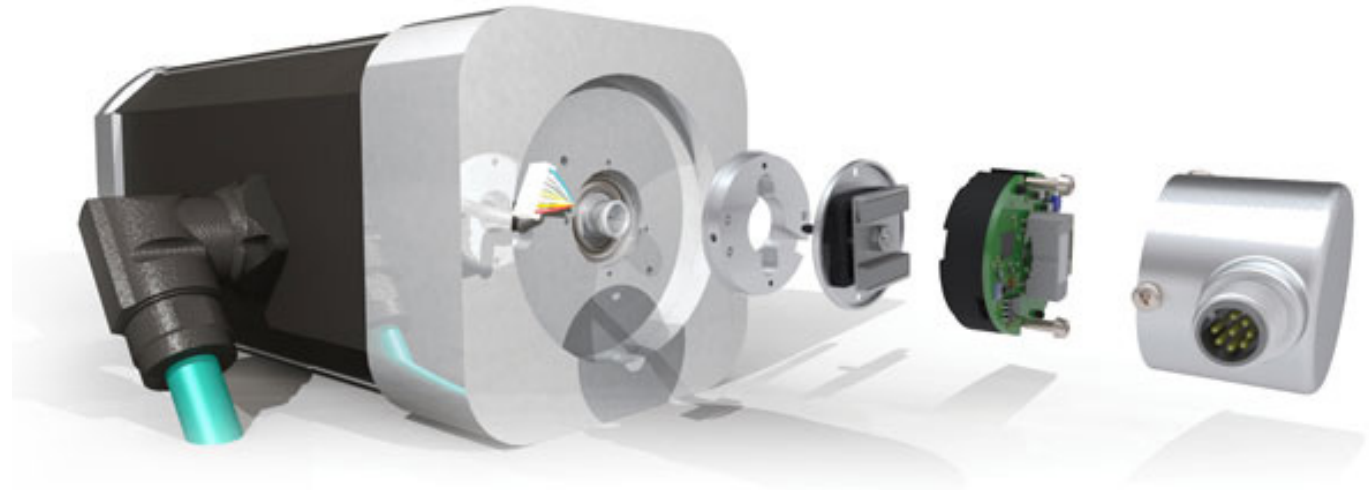

## Understand the variety of component-level sensor devices built into servomotors and other machinery

Closed-loop motion control systems use feedback to ensure the precise positioning of mechanical components. Self-contained position sensors, such as rotary encoders, can do a good job of providing this feedback. However, in some cases it is technically and economically preferable to build the sensors into the machinery being controlled, avoiding the cost and complexity of external measurement devices. This is the domain of kit (or modular) encoders—position sensor elements designed to be installed inside motor housings or other types of equipment and to measure drive shaft rotation directly.

### What are kit encoders?

Kit encoders are component-level devices, built into motors or other types of equipment to provide real-time measurement of rotary position or rotational speed. They are an essential component in



servomotors and can be used effectively in other kinds of machinery, including robots.

Compared to conventional self-contained encoders, kit encoders typically lack sealed housings, ball bearings, or separate shafts. Instead, they are intended to attach directly to the host machine's casing, with rotating components connected to the machine's shaft. This approach can reduce space requirements, lower costs, and lessen mechanical complexity. However, the environment inside motor or machine housings can be challenging, with high temperatures, strong magnetic fields, and vaporized lubricants. Choosing the right measurement technology is important to the overall success of a design.

## Magnetic resolvers

Magnetic resolvers are relatively simple devices that measure the angular displacement by monitoring changes in the magnetic coupling between windings on their rotor and stator components. They are physically robust, reasonably inexpensive, and work reliably over a wide range of operating temperatures. However, they also have limitations. Resolvers are analog devices that require an A/D converter in the controller interface. Most resolvers are also relatively low-accuracy devices without multiturn capabilities. Multipole resolvers can deliver higher levels of accuracy but are more expensive.

## Optical kit encoders

The key components of an optical kit encoder are a “code disk,” installed on the rotating shaft, an LED light source, and an array of photoreceptors. The disk is made of transparent material and carries a concentric pattern of transparent and opaque areas. The disk sits between the light source and the photoreceptors so that the pattern of light falling on the photoreceptors will change as the disk rotates. Signals from the photoreceptors are combined to provide an accurate measure of the rate of rotation and/or the rotation angle of the shaft.

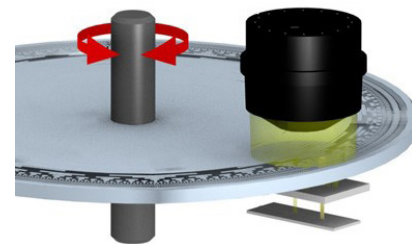

Kit encoders based on optical measurement technologies are available in a range of configurations and performance levels. At the high end, precision absolute optical measurement systems can have accuracies of  $\pm 0.02$  degree or better and very good dynamic response. These are suitable for advanced servomotors and precision position control applications.

At the other end of the price/performance scale, some manufacturers offer low-cost incremental encoders based on optical measurement technology. Although these have lower precision, they can be useful for providing closed-loop feedback control for inexpensive stepper motors. By clearly confirming if the motor was able to complete a step motion as instructed, this arrangement significantly improves the reliability of low-cost stepper motors for position control applications.

While optical encoders can provide excellent performance, code disks and photoreceptors are vulnerable to being contaminated by dust, oil, and condensation. In addition, to achieve maximum accuracy, code disks and photoreceptor arrays must be aligned very precisely. This can involve special assembly procedures carried out under near clean-room conditions. Optical code disks must have relatively large diameters—up to 50 mm—to achieve high resolutions. This means that high-accuracy versions of these instruments will be relatively large.

## Magnetic kit encoders

Magnetic kit encoders use an array of Hall-effect sensors to measure the rotary position of the magnetic field of a small permanent magnet fastened to the host machine's shaft. A microprocessor is required to interpret the signals from the Hall-effect sensors and calculate the rotational angle of the magnet. The mechanical simplicity of this measuring system means that magnetic kit encoders can be smaller and more rugged than their optical counterparts. Leading magnetic kit encoders offer 17-bit resolution and an accuracy of at least  $\pm 0.1$  degree. Latency is in the order of a few microseconds.



Magnetic kit encoders are compact and straightforward to integrate into motor or machine housings. The electronic module of POSITAL's magnetic kit encoders, which includes the Hall-effect sensor array, the signal processing electronics, and the chips supporting the communications interface, is 37 mm in diameter and 24 mm deep. For servomotors with magnetic brakes, a magnetic shield may be required to isolate the magnetic pickups in the measurement system from strong magnetic fields.

### Incremental or absolute measurements

Incremental encoders send a stream of signal pulses to the controller as the device's shaft rotates. The relationship between rotation speed and pulse rate is defined by the device's resolution, expressed as the number of pulses per rotation (PPR). Most incremental encoders also report the direction of rotation.

**Incremental encoders** are ideal for speed control, because they provide a real-time reading of the rotation rate. Incremental encoders can be used for positioning tasks, with the control system keeping track of absolute position by counting the number of pulses received from the encoder. However, when positioning systems are built around incremental encoders, this position count could be lost or corrupted during a power failure or system shutdown. In this case, it may be necessary to return the machinery to a known reference position and restart the position count before operations can resume.

**Absolute encoders** provide a snapshot reading of the shaft's angle of rotation, usually as a multibyte digital "word," in response to a request from the system's controller. For multiturn absolute encoders, the output combines the angle of rotation with a count of the number of complete rotations that the encoder shaft has experienced. Absolute encoders are ideal for positioning tasks, since most can report their complete absolute rotational position (including the number of complete turns) immediately on startup. This eliminates the position-reset problem encountered with incremental encoders.

## Hollow shaft kit encoders

Most of the encoders discussed so far have position-sensing elements that are positioned at the center of the device. While this is satisfactory for many applications, there are situations where designers would prefer to use measurement devices that fit around a central shaft, axle, or structural element. For example:

- ▶ For servomotors, stepper motors, or drives, it can be convenient to measure shaft rotation with a position sensor that fits around the drive shaft.
- ▶ Robot joints can be designed with a central hinge, or with electrical cables and air hoses routed through the center of the joint. Devices that measure the joint angle while fitting around these structural elements can be used to create more compact joints.

Ring-shaped or hollow shaft kit encoders are designed to meet these requirements and give designers more flexibility when configuring motion control systems. With these devices, designers of servomotors or feedback-controlled stepper motors can lay out their equipment with position sensors at either end of the motor's shaft.

Hollow shaft encoders are usually based on capacitive measurement systems. Each encoder has two principle components, a stator and rotor, both with specially shaped areas of conductive material on their surfaces. These function as capacitor plates. As the rotor turns, the relative position of the conductive areas on the rotor and stator change, causing changes to capacitive coupling across the system. This is used to alter the amplitude and phase angle of a high-frequency electrical signal generated by exciter circuits in the stator and transmitted through the capacitor system. Special processors capture and decode these signal variations and determine the rotor's angular position to a high level of precision. Hollow shaft kit encoders based on capacitive measurement systems can have excellent accuracy ( $\pm 0.02^\circ$ ) and dynamic response (up to 6000 RPM). This makes them suitable for use in critical motion control systems.

Both stator and rotor elements are in the form of thin disks with large central openings. Their low height (18 mm) makes them a good choice for space-limited situations, such as servomotors, stepper motors, or the joints

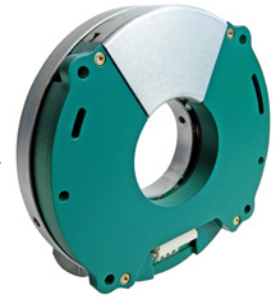

in robotic arms, where it may be desirable to have an embedded position sensor that fits around a central shaft, structural element, or cable cluster.

In summary, the hollow center configuration provides designers with extra flexibility when laying out machinery. Accuracy is very high, with 19-bit resolution (one part in 524,288). Since capacitance measurements are taken around the full circumference of the rotor/stator disks, these systems can be relatively tolerant of minor alignment errors between the stator and rotor and can be installed in servomotor housings or other machines under reasonably clean factory conditions. (By contrast, optical encoders require very precise internal alignment and are typically assembled under laboratory-like conditions.)

Capacitive measurement systems are relatively tolerant of dust and moisture, both during assembly and in operation. They are largely immune to magnetic fields, including the strong fields from motor brakes. They can, however, be sensitive to strong electrical fields, so that shielding is generally recommended.

## **POSITAL**

### FRABA



### **Meet POSITAL's Kit Encoder Family!**

Precision Motor Feedback for Servo and Stepper Motors

Flexible Encoder Solutions for Small Drives, Robots

Incremental, Absolute, Singleturn and Multiturn Variants

[www.posital.com](http://www.posital.com)

## Multiturn measurements

For servomotors or drives, multiturn measurement capabilities can be useful for monitoring the position of mechanical components when, for example, a motor drives a screw shaft, a cable drum, or a reduction gear system.

Resolvers are single-turn devices and are not available with multiturn measurement ranges.

For most optical encoders, multiturn measurements are enabled by adding a series of secondary code disks, geared together so that each successive disk in the train rotates at a fraction of the rate of the disk

	Magnetic resolver	Optical encoder	Magnetic encoder	Hollow shaft (capacitive technology)
Single-turn measurement technology	Magnetic induction between rotating and static coils	Rotating code disk and opto-electric sensor array	Hall-effect sensors measure field from rotating magnet	Capacitive coupling between stator and rotor elements modulates high-frequency signal
Multiturn measurement technology	N/A	Typically geared code wheels or electronic counter with backup battery	Self-powered electronic counter	Self-powered electronic counter available
Cost	\$	\$\$\$	\$\$	\$\$
Size		Typically > 36mm $\phi$	36 mm $\phi$ ., 24.2 mm deep	Available with 30- or 50-mm central opening
Accuracy	Low: $\pm 0.2^\circ$	$\pm 0.02^\circ$	Higher: $\pm 0.1^\circ$	$\pm 0.02^\circ$
Ruggedness	High	Code disk and sensors can be damaged by shock and vibration	High	High
Sensitivity to moisture, dust	Low	Requires clear optical path across code disk		Low
Output signal	Analog – A/D conversion required for digital controllers	Digital		Digital
Maintenance free?	Yes	Less expensive versions include a backup battery that needs to be replaced every two years	Yes	



driving it. This system has been used successfully, but it is costly and mechanically complex.

Multiturn magnetic encoders typically use some form of electronic rotation counter. This retains the mechanical simplicity that is a key characteristic of magnetic technology. However, for electronic counters, it is important to ensure that they can maintain an accurate count of the number of complete revolutions that the device has experienced, even if these rotations occur when instrument power is not available. (If a rotation counter fails to record every mechanical revolution, positional accuracy is lost. In this case, it may be necessary to “re-home” the system by returning the entire machine to a known reference state, then reinitiating the rotation count.) To ensure accurate position counts under all operating conditions, some encoder manufacturers include a backup battery to keep the rotation counter energized when instrument power is unavailable.

Encoder manufacturer POSITAL has an innovative approach to powering the electronic rotation counters on its magnetic and capacitive kit encoders. The rotation counting system is self-powered. With each shaft rotation, pulses of electricity created by a “Wiegand wire” system mounted on the encoder generate electrical current that provides enough energy to activate the rotation counter. This system operates independently of any external power source. Eliminating the need for batteries reduces downtime, lowers maintenance costs, and avoids the need to dispose of spent batteries.

## Stepper motors with position feedback – A low-cost option

While servomotors are a popular choice for precision motion control in industrial machinery, the improved performance of stepper motors is making these lower-cost devices an attractive alternative for many applications. The key to these performance gains is the addition of rotary position measuring encoders.

Stepper motors are brushless DC motors that turn their shaft by a small fixed amount (step) in response to a control signal. In its basic form, this is an open loop control system: if the motor fails

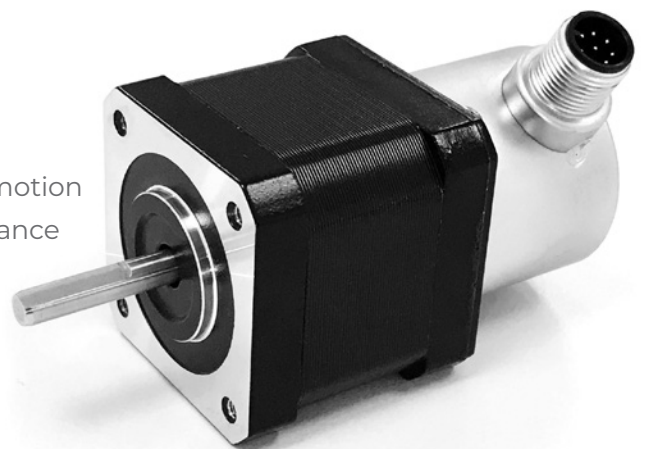

to complete a step (e.g., due to unexpected mechanical resistance), system accuracy is degraded. This can be overcome by adding a simple incremental encoder that can confirm that step motions have occurred. Absolute encoders take this a step further by providing absolute position feedback.

Absolute kit encoders from POSITAL are available with multiturn measurement ranges, which can be very useful when a motor is connected to a screw shaft, cable drum, or gear reduction system. The multiturn rotation counter is self-powered, using POSITAL's Wiegand energy harvesting technology. The rotation count is always up to date, even if the machine has moved while control system power was out. No backup batteries are required!

Kit encoders for stepper motors are designed to be integrated into a motor housing, measuring the rotary position directly from the drive shaft. Kit packages are available with the same mounting form factor as popular incremental encoders for NEMA-standard stepper motors, making these encoders convenient drop-in replacements for less advanced incremental encoders. The magnetic measurement module is compact (37 mm diameter, 23 mm deep) and highly resistant to dust, moisture, and shock/vibration loading. Shields are available to protect the measurement module from external magnetic fields. SSI and the more advanced "BiSS C" communication interfaces have been implemented. Both are open-source interfaces that are compatible with a wide range of programmable logic controllers and computers.

Stepper motors with built-in position sensors are an increasingly attractive solution for positioning tasks in manufacturing equipment, packaging machinery, robots, and other applications where a reliable, cost-efficient drive mechanism is needed.

---

#### ABOUT THE AUTHOR



**Christian Fell**, head of POSITAL's North American operations, is also the company's vice president for technology. Fell joined the FRABA Group in 2000 and became an equity partner in 2007. He has a master's degree in physics from the Gerhard Mercator University, Duisburg, Germany, and a diploma in medical physics from the Technical University of Kaiserslautern.



International Society of Automation

Setting the Standard for Automation™



# ISA Virtual Events Program

[www.isa.org/virtualevents](http://www.isa.org/virtualevents)

ISA is proud to offer a new virtual event lineup covering a variety of critical industry topics including live webinars, on-demand conferences, and ISA Connect Live.

ISA's Virtual Events Program is a safe, convenient alternative to in-person technical conferences, providing our attendees with key operational and business solutions through user-friendly online sessions, top-notch keynote speakers and panel discussions with live Q&A, simulated exhibit halls, as well as valuable networking and chat opportunities.

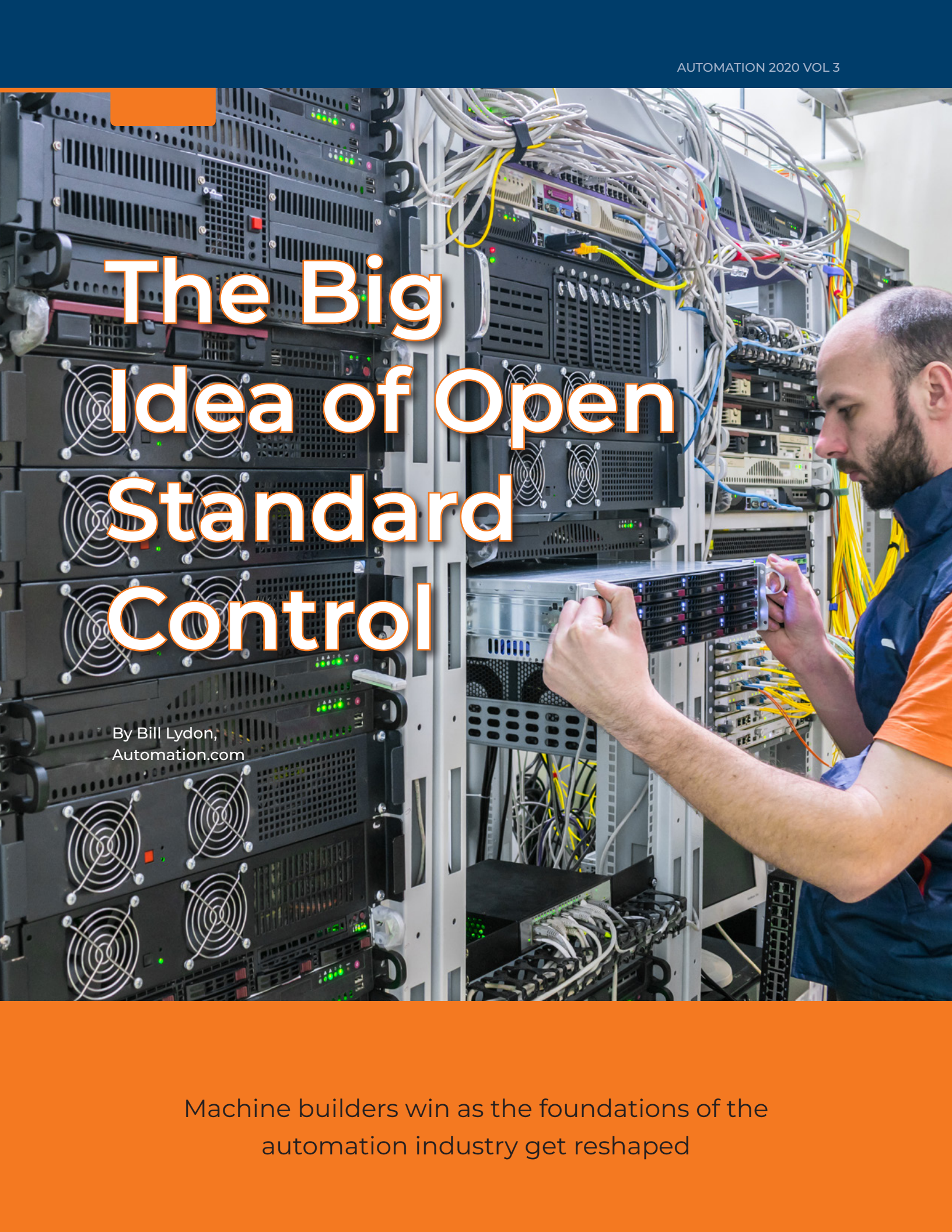
A photograph of a technician in a dark blue shirt and orange sleeves working on a server rack in a data center. The rack is filled with various server units, some with cooling fans and indicator lights. A dense network of cables is visible at the top of the rack. The technician is focused on a specific unit, using a tool. The background shows more server racks and the typical environment of a data center.

# The Big Idea of Open Standard Control

By Bill Lydon,  
Automation.com

Machine builders win as the foundations of the automation industry get reshaped

Machine builders are finally starting to benefit from open standard control software. By leveraging this software, they are finding more ways to apply their know-how and creativity to deliver greater customer value with unbundled IEC 61131-3 control and automation software.

Industrial automation, too, is starting to benefit from the dramatically increased power (at a lower cost) of computing technologies, which has been driven by consumer electronics and the Internet of Things (IoT), along with the unbundling of hardware and software.

The foundations of the automation industry are being reshaped by this flood of ideas, software, and products, which have been driven by Industry 4.0 and the digitalization of the manufacturing and process industries. The industrial automation industry is experiencing sweeping, fundamental change with the application of IoT, sensor advances, embedded controllers, and other technology improvements.



●●●●● **With hardware manufacturer-independent software** conforming to the IEC 61131-3 standard, machine builders are free to select computing platforms that are the best fit for an application.

## Industrial controller unbundling

In the past, industrial process controllers and programmable logic controllers (PLCs) have been proprietary software and hardware for executing control sequences and algorithms. With the unbundling of hardware and real-time control software based on open international standards, however, this is rapidly changing.

The computer industry unbundled hardware and software years ago during the PC revolution and saw positive results: namely, increased efficiency and a dramatic broadening of applications by unleashing the skills, know-how, and creativity of subject-matter experts.

Likewise, with the availability of hardware manufacturer-independent automation and control software conforming to the IEC 61131-3 standard, machine builders are free to select computing platforms that are the best fit for an application. By leveraging this international programming standard for industrial control and automation, any processor can become a controller, potentially creating higher value for users and improved support efficiency.

## The IEC 61131-3 standard

IEC 61131-3:2013 specifies the syntax and semantics of a unified suite of programming languages for industrial and process automation. This suite consists of two textual languages—Instruction List (IL) and Structured Text (ST)—and two graphical languages—Ladder Diagram (LD) and Function Block Diagram (FBD).

In addition, sequential function chart (SFC) is a visual programming tool to create multithreaded and synchronized control and operations. Most vendors also provide the ability to add functions into the architecture

## About IEC, the International Electrotechnical Commission

Founded in 1906, the International Electrotechnical Commission (IEC) is the world's leading organization for the preparation and publication of international standards for all electrical, electronic, and related technologies. These are known collectively as "electrotechnology." Millions of devices that contain electronics and use or produce electricity rely on IEC international standards and conformity assessment systems to perform, fit, and work safely together.

IEC provides a platform to companies, industries, and governments for meeting, discussing, and developing the international standards they require. All IEC international standards are fully consensus-based and represent the needs of key stakeholders of every nation participating in IEC work. Every member country, no matter how large or small, has one vote and a say in what goes into an IEC international standard.

through application programming interfaces (APIs) for languages including C and C++. Therefore, this standard defines strong data types and input/output data standards.

PLCopen is a vendor- and product-independent worldwide association that both certifies vendor conformance to IEC 61131-3 and extends the standard. Current extensions include safety, motion control, OPC-UA, XML Exchange, and reusability.

In addition, PLCopen works with other open standards groups to ensure interoperability and greater productivity for automation engineers. Notable cooperative working groups include OPC-UA, with PLCopen defining the OPC-UA function blocks. The goal is to enable application engineers to easily accomplish peer-to-peer control and information exchange between multivendor controllers and call-up methods in an OPC-UA server in enterprise systems, including manufacturing execution systems (MESs) and enterprise resource planning (ERP), in order to achieve synchronized manufacturing and Industry 4.0 goals.

## Supporting edge computing

Unbundling means that the control software can run on almost any platform, including edge computers and system-on-a-chip (SoC) devices programmed in a uniform IEC 61131-3 standard. IEC 61131-3 standard controls are being embedded into edge devices, such as valve blocks, cameras, and motor drives.

The common thread of all these devices is standardized programming, configuration, and multivendor interoperability. Furthermore, a range of edge computing platforms can be used as PLCs and process controllers. These range from powerful “brick” PCs to Raspberry Pi devices that provide higher performance at lower cost than traditional proprietary bundled PLCs and process controllers.

This open unbundled approach is consistent with machine builder efforts to improve flexibility and competitiveness—analogueous to what happened in the computing industry. Companies that



**Leveraging the IEC 61131-3** international programming standard for industrial control and automation, any processor can become a controller.

continued to use closed proprietary computing to run their operations eventually became inefficient and ineffective and were soon being leapfrogged by competitors.

The adoption of new technology during times of significant innovation is critical for manufacturing success, and machine builders can be important change agents for users. Machine builders that understand how to leverage unbundled IEC 61131-3 control and automation software with the appropriate hardware platforms can help users outpace their competitors and be more successful.

*This article originally appeared on Automation.com in October 2019.*

---

#### ABOUT THE AUTHOR



**Bill Lydon**, contributing editor for Automation.com, is an experienced industrial, process, and building automation professional with a design and applications background. He has worked for large companies and cofounded a startup in the automation industry. Lydon is active in the automation industry and his articles appear regularly in Automation.com and *InTech* magazine.

#### Related articles on Automation.com

- ▶ [Automation Controllers & Word Processors – Embrace the Technological Shift or Die](#)
- ▶ [The IoT Impact on Business Models: What Should Manufacturers Do First?](#)
- ▶ [The New Era of Automation Architectures: What does it mean for users?](#)
- ▶ [Industry 4.0: Intelligent and flexible production](#)
- ▶ [Powering Industry 4.0 & Industrial IoT](#)
- ▶ [Disruptive Technologies Make or Break Your Business](#)



# Industrial Cybersecurity is a Global Imperative

**It's time to join forces. We are stronger together.**

The ISA Global Cybersecurity Alliance is an open, collaborative body. We welcome members of all kinds:

- end-user companies
- asset owners
- automation and control systems vendors
- cybersecurity technology vendors
- IT infrastructure vendors
- services providers
- system integrators
- industry organizations
- government agencies
- insurance companies
- other stakeholders

## Founding Members:



Founding Members:

- Honeywell
- Johnson Controls
- Rockwell Automation
- Life Is On
- Schneider Electric
- NOZOMI NETWORKS
- PAS
- CLAROTY
- WALLIX
- xage SECURITY
- MOCANA
- BAYSHORE
- radiflow
- senhasegura
- INL
- 威努特 WINICSSEC
- exida
- munio SECURITY
- tenable
- DRAGOS
- Ti Safe
- ae Solutions
- tripwire
- DIGITAL IMMUNITY
- WisePlant
- MSI
- 1898
- ACET SOLUTIONS
- CYBEROWL
- Nova Systems

# Case Study: Machine Builder Conquers Adaptive Limitations with PC Control

Whether manufacturing packaging machines or components for airliners, companies must be able to guarantee all metal parts will remain strong and dependable throughout the product's life cycle. Recognizing this challenge, LSP Technologies (LSPT) pioneered a method for engineers to increase the strength of metals in manufactured goods: laser peening. Peening describes the bombardment of metal workpieces with other objects, whether peening hammers, small pellets, or high-powered lasers, to mitigate the effects of metal fatigue. The objects press the material into itself to make it denser and, as a result, stronger.

Robotics, EtherCAT, and flexible PC-based automation combine to create complex and customized laser peening systems

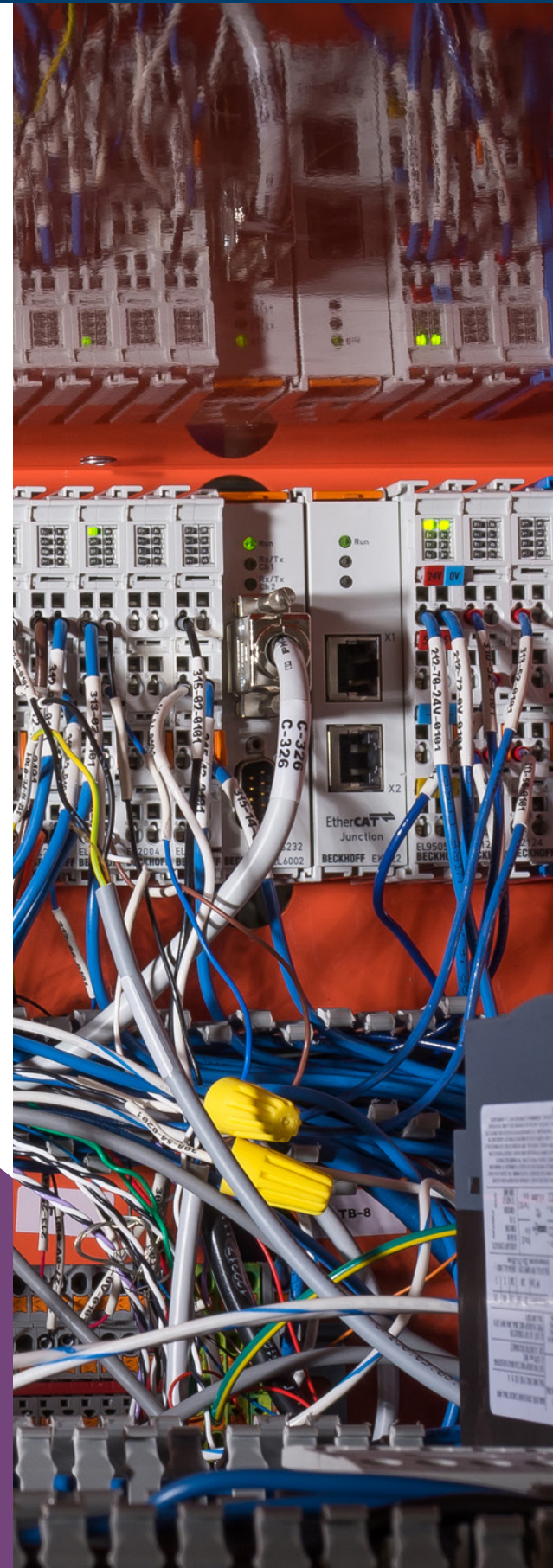

With laser peening, a high-powered beam is directed at the metal surface while a stream of water flows over the workpiece. The beam impacts the surface of the metal, creating a small explosion between the water and the surface of the part, which forces the shockwaves to travel deep into the metal, thus creating a material with a higher fatigue life.

Founded in 1995, LSPT provides laser peening services and equipment for many industries, such as aerospace, automotive, and maritime. The Dublin, Ohio-area company is the only one in the world that sells, installs, and integrates custom laser peening systems in customer facilities. “We started the business by providing lasers for this process, and then we decided to provide laser peening as a service,” says David Lahrman, vice president of business development at LSPT. “However, to make this a pervasive technology, we also needed to supply machines directly to companies that rely heavily on the laser peening process.”

## Design for the system is never final

One of LSPT’s most recent advances is the modular Procudo Laser Peening System—a self-contained turnkey system that offers installation and customization. The standard Procudo Laser Peening System fires its diode-pumped pulsed YLF lasers up to 20 hertz, and it measures 56 inches wide, 68 inches tall by 132 inches long. Because LSPT creates tailor-made Procudo Laser Peening Systems for use at customer facilities, the design for the system is never final, and some iterations of the system



The Procudo Laser Peening System from LSP Technologies offers modular and highly customizable systems, ranging from smaller designs (shown) with pole-mounted HMI to designs that comprise numerous room-sized machine cells.

have machine cells the size of large rooms to accommodate multiple articulated robots. No matter the custom requirements, laser peening is a complex process requiring effective machine control for motion and laser synchronization, and LSPT had to consider all components carefully when designing the system.

With laser peening equipment, flexibility and customization are crucial. Metal parts, especially large or awkwardly shaped components, are often difficult to move within a machine cell when accommodating fixed-position lasers. This is particularly challenging with workpieces like massive ship hulls and anchors in the maritime industry, for example. “In the past, we generally used part-to-beam processing by aiming the laser at a fixed point in the processing cell and then moving the parts with robotics,” Lahrman says. “To process very large parts, however, we now use beam-to-part processing, which involves moving the laser with robotic arms from KUKA robots to peen areas that require treatment.”

Flexibility is key as well, since each customer has unique requirements. Whenever LSPT engineers install new systems or process new components in house, they must make significant changes. It is not as simple as shipping out a prepackaged product.

For this reason, it is also critical that the automation and controls technology used in the Procudo Laser Peening Systems is highly scalable. The equipment must be able to handle workpieces that are very large, as well as others that focus on the smallest, most precise details.

## **Synchronization of technology is essential**

Another important factor is the standardization and synchronization of the technology. Dynamic software and hardware systems must communicate and cooperate seamlessly even in multivendor applications. To meet these challenges, LSPT sought technologies that were reliable, accurate, and fast. The system’s complex requirements made Beckhoff Automation a fit for LSPT.

LSPT addresses each Procudo Laser Peening System’s technical requirements and challenges by incorporating scalable, flexible

automation technology. The company was drawn to Beckhoff initially because of its interface options, including human-machine interface (HMI) hardware that is customizable for wide-ranging applications, and a rugged design for industrial environments.

Both the built-in CP2912 multitouch control panel and the pole-mounted CP3913 multitouch control panel give LSPT the options needed for unique client demands, according to controls engineer Alex Portolese. “For smaller Procudo Laser Peening System designs that require standalone HMI panels, we implement the CP3913 to interface with the finer controls of the laser system. However, the CP2912 is the standard control panel for the Procudo Laser Peening System, as it works well for custom applications and mounts directly to electrical cabinets,” he says.

Leveraging PC-based control from Beckhoff, LSPT also uses the CX2040 embedded PC, featuring quad-core, 2.1-GHz Intel Core i7 processors, to run HMI, connect to the cloud, and communicate between the Procudo Laser Peening System and higher-level systems. “We like the power and small form factor of the CX2040. With the addition of SQL databases, this allows us to maintain compact electrical cabinet footprints,” Portolese explains. However, the Procudo Laser Peening System’s standard control hardware for robotics and other laser peening functions is the C5240 industrial PC (IPC). TwinCAT 3 automation software gives LSPT the flexibility to complete all programming in a standard engineering environment, according to Keith Glover, head of electrical engineering at LSPT. In addition, TwinCAT can scan and automatically configure third-party devices over Automation Device Specification (ADS) and EtherCAT, significantly reducing commissioning times for machines like the Procudo Laser Peening System that have multivendor architectures.

“Fast communication with third-party industrial devices or existing factory fieldbuses is a key advantage of TwinCAT,” Glover says. “Implementing special protocols in serial modules and TCP-IP modules, for example, is easier with the Beckhoff platform compared to others.” This helps when implementing complex systems with robotics.



Laser peening reduces metal fatigue through a process that involves firing a high-powered laser beam at a workpiece while a spray of water contains and focuses the resulting plasma explosion to improve the part.



The Procudo LSP system relies on a variety of EtherCAT and PC-based control technologies from Beckhoff, including CX2040 embedded PCs and TwinSAFE terminals that enable integrated safety using the same network and engineering environment as standard machine control.

## Precise motion control is crucial

Precise motion control and EtherCAT communication are crucial for the Procudo Laser Peening System. As a KUKA Gold partner, LSPT implements multiple articulated robots to move lasers, and sometimes also workpieces, to ensure that the beams strike parts with high accuracy. AM8000 servomotors from Beckhoff have a robust design with long-lasting life cycles and are equipped with one cable technology (OCT), which saves space and costs by combining feedback and power in a single cable.

“We have used the AM8000 servomotors quite heavily in recent Procudo Laser Peening System projects involving beam-to-part processing. The motors help move the beam closer to the target part to complete the laser peening process,” explains Portolese.

As the fastest fieldbus, EtherCAT provides communication for more than the robotics in the modular Procudo Laser Peening Systems. A range of EtherCAT I/O modules from Beckhoff provides scalable networking solutions for LSPT. Inside the machine cells where

high moisture is present, LSPT uses water-resistant, IP 67-rated EtherCAT box modules. LSPT uses standard EL-series EtherCAT I/O terminals in electrical cabinets due to their compact form factors and numerous channels for all common sensors, actuators, and other field devices.

The Procudo Laser Peening System also implements integrated safety through TÜV-certified TwinSAFE options. Safety programs are created in TwinCAT and then transferred to devices throughout the Procudo Laser Peening System, including EL6900 TwinSAFE Logic terminals in standard I/O segments and EP1908 EtherCAT Box modules inside the peening cell.

The systems take various forms depending on customer requirements, but each one receives significant advantages by leveraging PC control from Beckhoff. LSPT achieved its goals for flexibility, enabling the Procudo Laser Peening System to emit an 8 to 16 nanosecond pulse containing 10 joules of energy. While the laser has a standard repetition rate of 20 hertz, it can also achieve firing speeds ranging from 1–200 hertz.

Beckhoff-LSP-Technologies-5: Along with CX2040 Embedded PCs, the Procudo® LSP system relies on a number of EtherCAT and PC-based control technologies from Beckhoff.

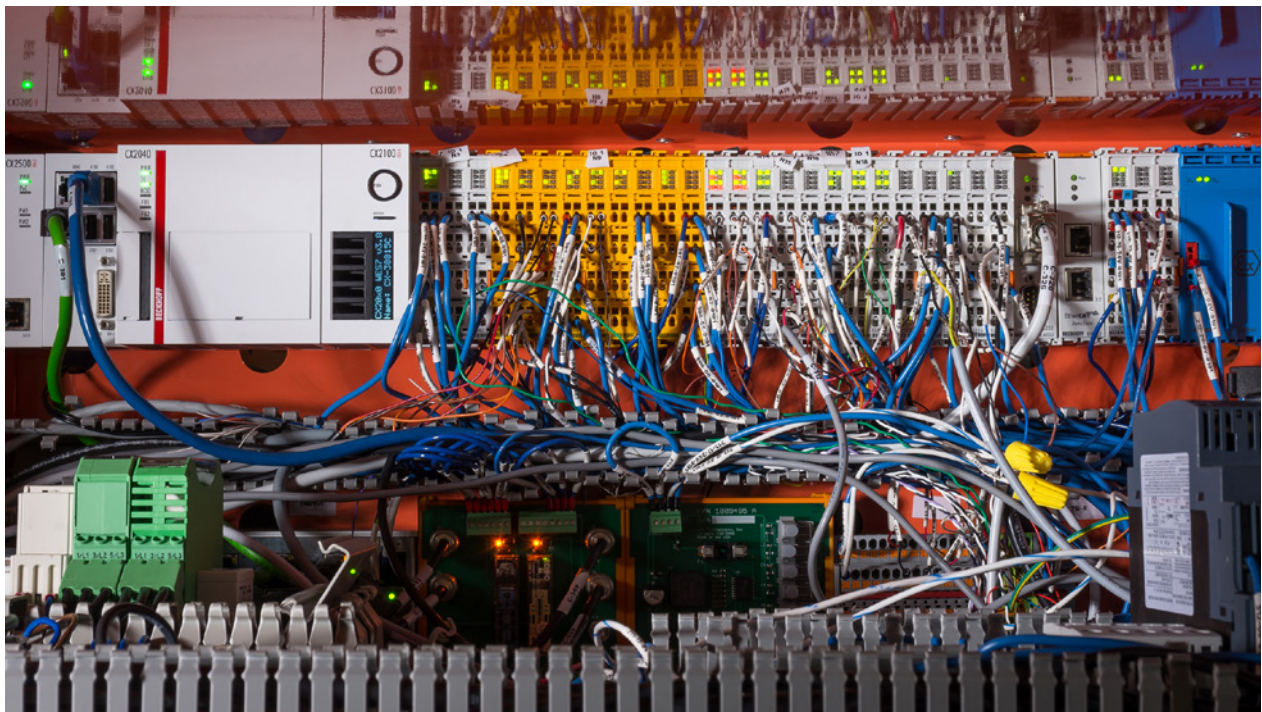

As a result of the high synchronization possible with TwinCAT and EtherCAT, the system can process up to 29 square inches (187 square centimeters) of material per minute. In addition, the Procudo Laser Peening System offers high levels of customization through open, scalable technologies, and this is a significant benefit, according to Lahrman. “We are always excited by the opportunity to create new solutions for our customers,” he says.

While flexibility and customization are major cornerstones of Beckhoff technology, another focus is synchronization. These benefits continue to be compelling reasons for LSPT to implement Beckhoff technologies, according to Glover.

“What led us to choose Beckhoff from the technology side was the speed and real-time determinism of EtherCAT and TwinCAT. The ability to have the same networking and software combination on the same device with high-speed data sharing was critical,” he says. “Additionally, the ability to synchronize motion with the laser output is critical to the repeatability and quality of our processes, enabling us to reliably provide the benefits of laser peening to customers across many industries.” The Procudo Laser Peening System from LSP Technologies offers modular and highly customizable systems, ranging from smaller designs (shown) with pole-mounted HMI to designs that comprise numerous room-sized machine cells.

---

LSP Technologies (LSPT, [www.lsptechnologies.com](http://www.lsptechnologies.com)) pioneered laser peening, a method for engineers to increase the strength of metals in manufactured goods. It now creates tailor-made Procudo Laser Peening Systems for use at customer facilities.

Beckhoff Automation ([www.beckhoffautomation.com](http://www.beckhoffautomation.com)) makes PC-based control technology that serves as a central and open control platform for all machine functions and optimally supports the implementation of highly efficient IoT-based automation concepts. Machines, systems, and production lines can be networked to increase efficiency potential across processes. Its TwinCAT 3 automation software recently was extended to include artificial intelligence functions, and the entire engineering platform is now available in the cloud.