

VRF VS Chiller

Jimmy Liao
Technical Manager

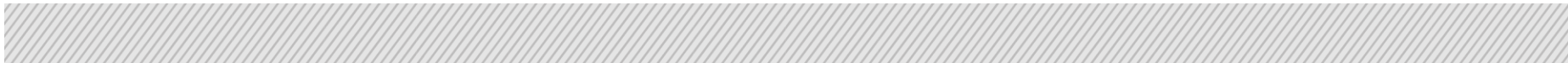

General Info

Benefits of VRF Systems

Benefits of Chiller Systems

Conclusions

General Info

Benefits of VRF Systems

Benefits of Chiller Systems

Conclusions

What is a VRF System?

V R F

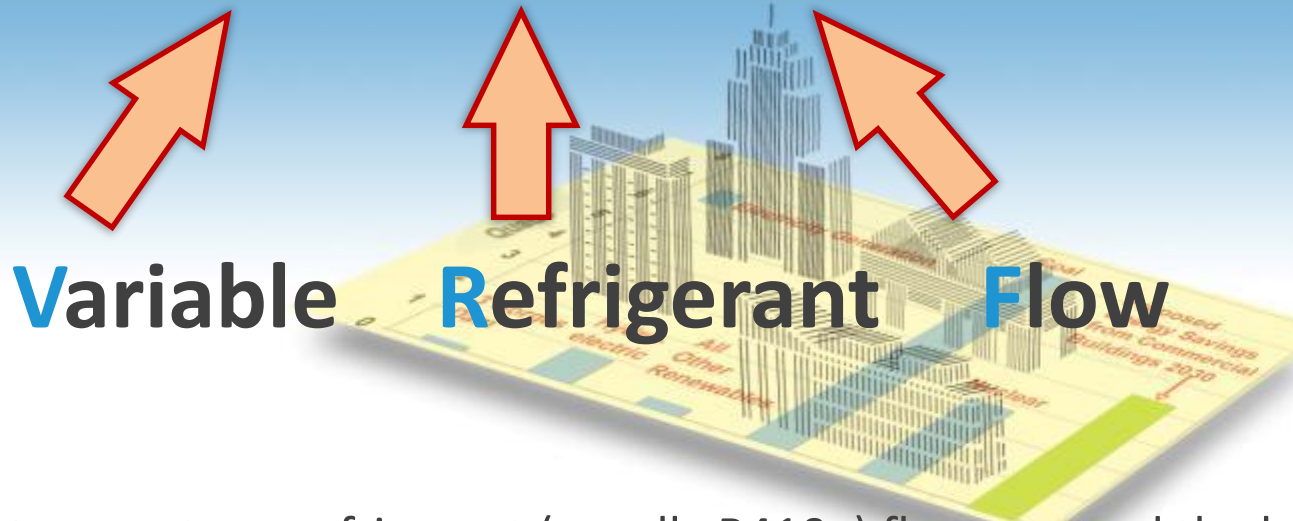

- DX-type system: refrigerant (usually R410a) flows around the building in copper pipes
- Consists of outdoor units, indoor units, branch joints, copper pipes, controllers
- One outdoor system can drive multiple indoor units
- Suitable for most medium-sized commercial buildings (<70,000 ft²), and some larger buildings

Typical VRF system layout

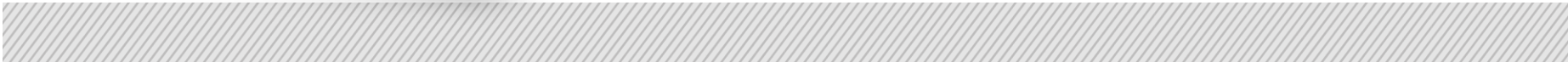
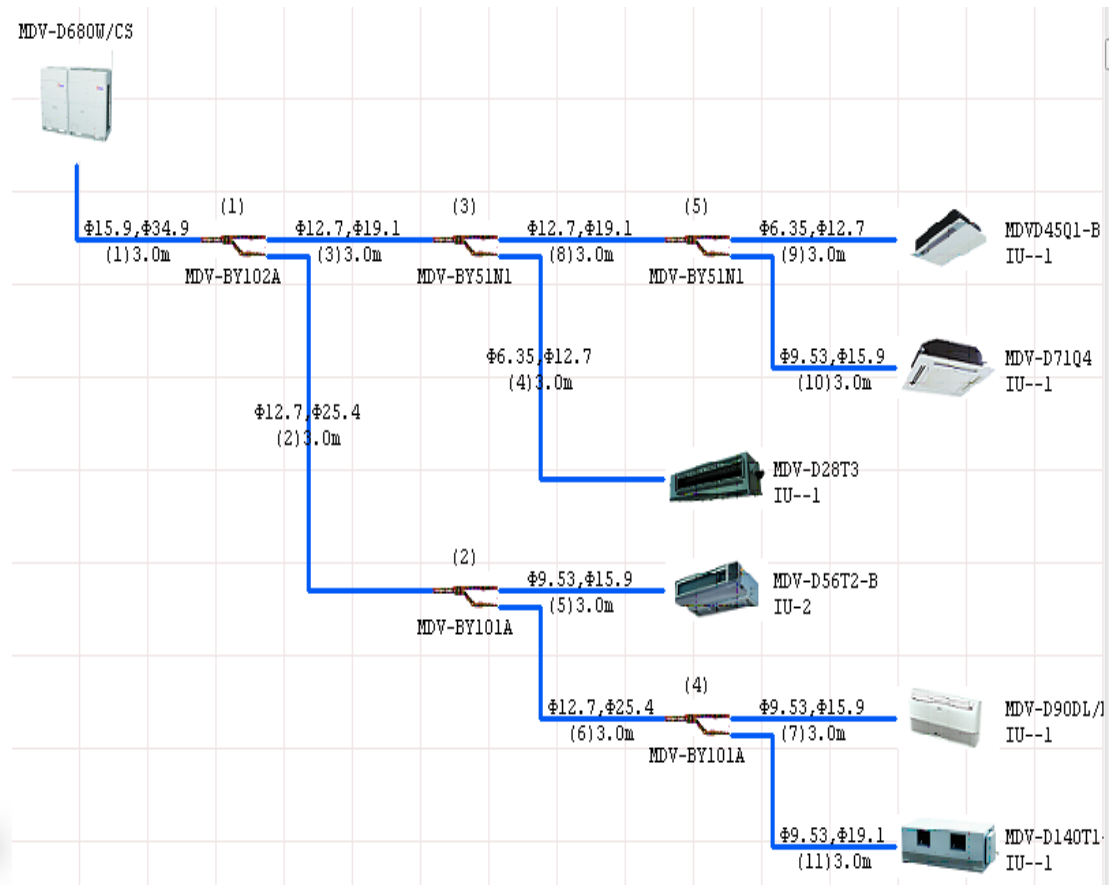
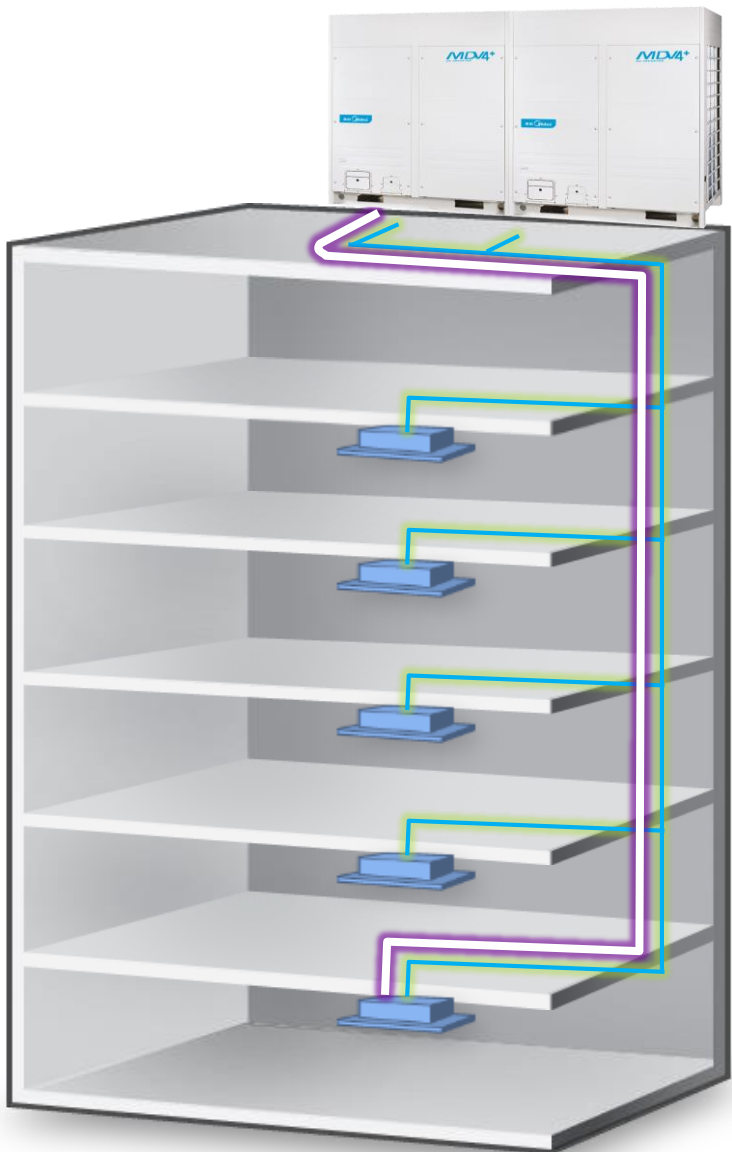

VRF system modulation

- Tandem/Trio (LG-MPS)

Multiple constant ON/OFF compressors

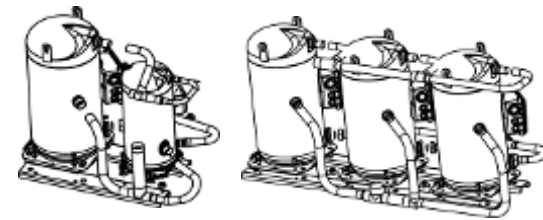

- Digital (Midea/Samsung/McQuay)

Mechanical loading/unloading

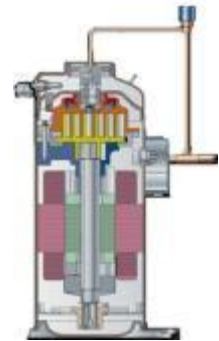

- Inverter (Midea/Daikin/LG/Toshiba/MHI/ME)

Variable speed compressor motor



Typical VRF applications

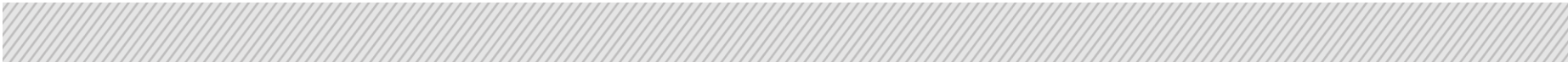

What is a chiller system?



Water-cooled chiller

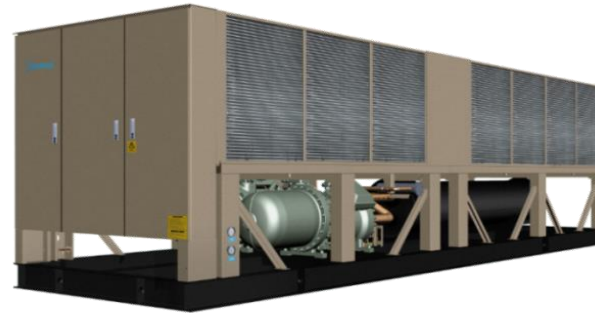

Air-cooled chiller

- Refrigerant (usually R134a) only cycles inside the chiller unit - water (or a mixture of water and anti-freeze) acts as second heat-transfer medium and flows around the building in steel/plastic pipes
- Consists of chiller units, FCU/AHU indoor units, water pumps, water pipelines, cooling towers, valves, controllers
- Suitable for most of large commercial buildings and some of the medium-sized buildings

Typical chiller applications



Typical chiller applications

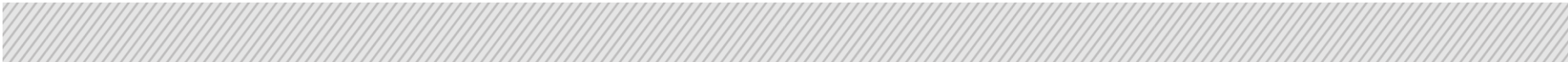

Typical water-cooled chiller system layout

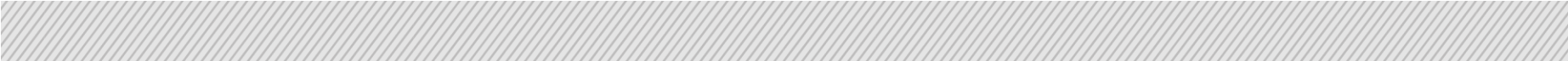
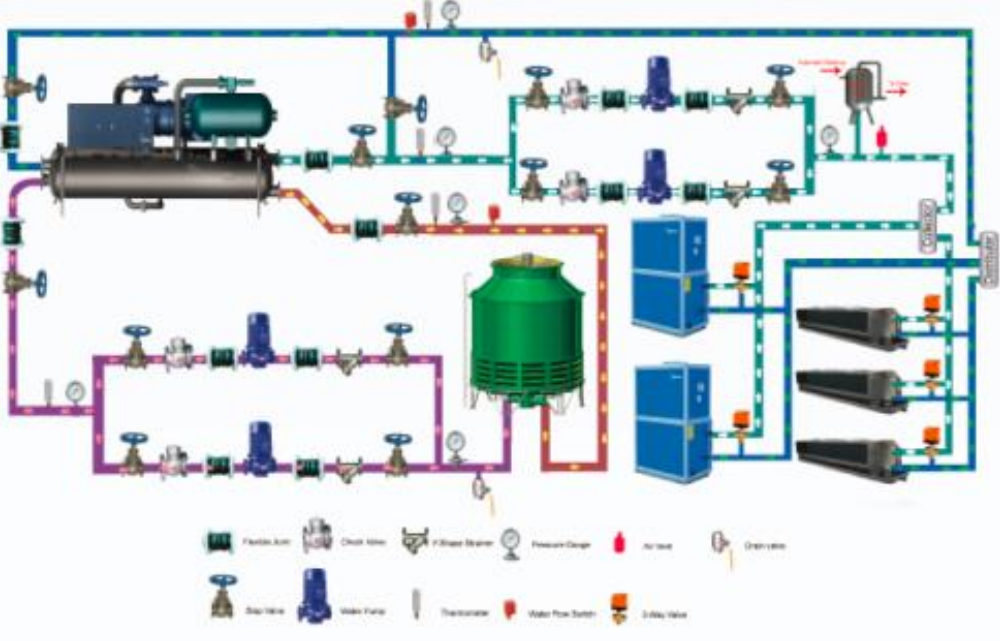
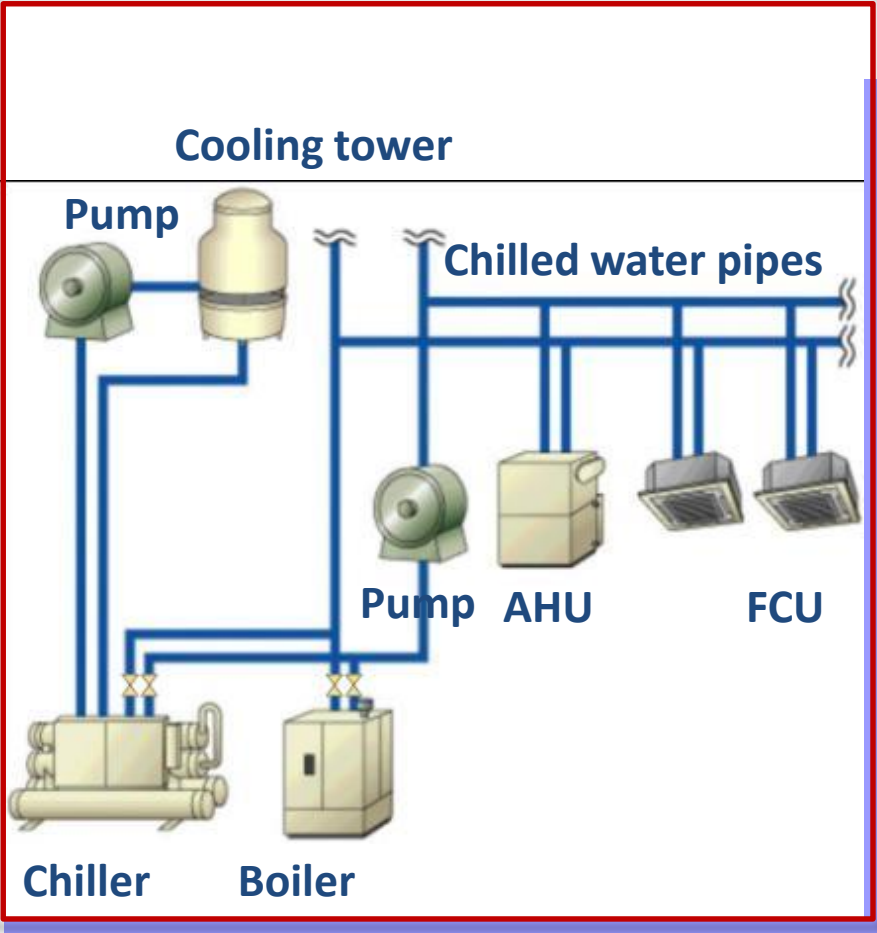

Typical air-cooled chiller system layout

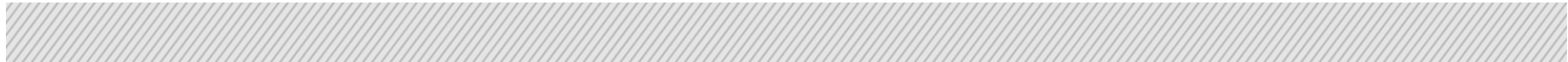
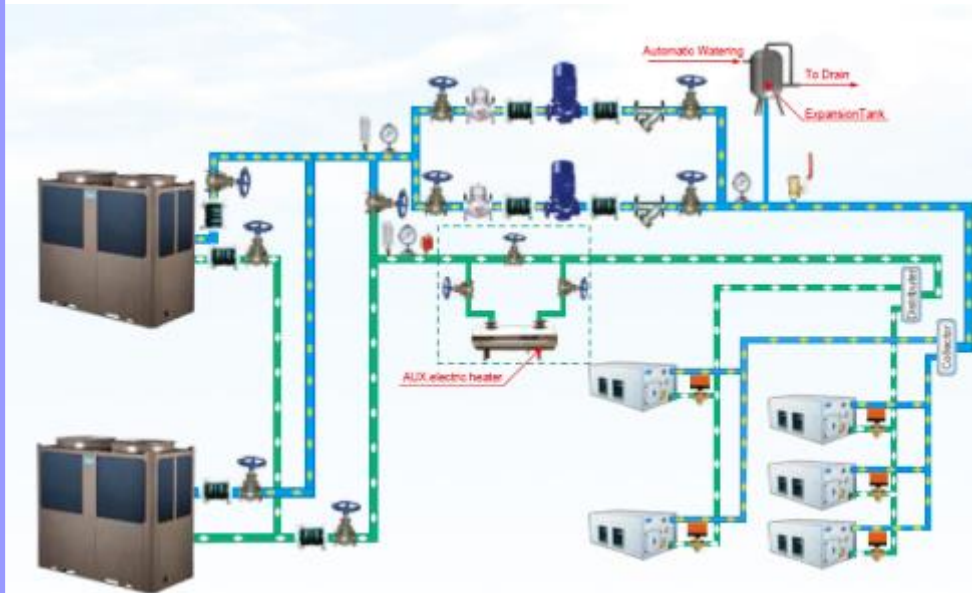
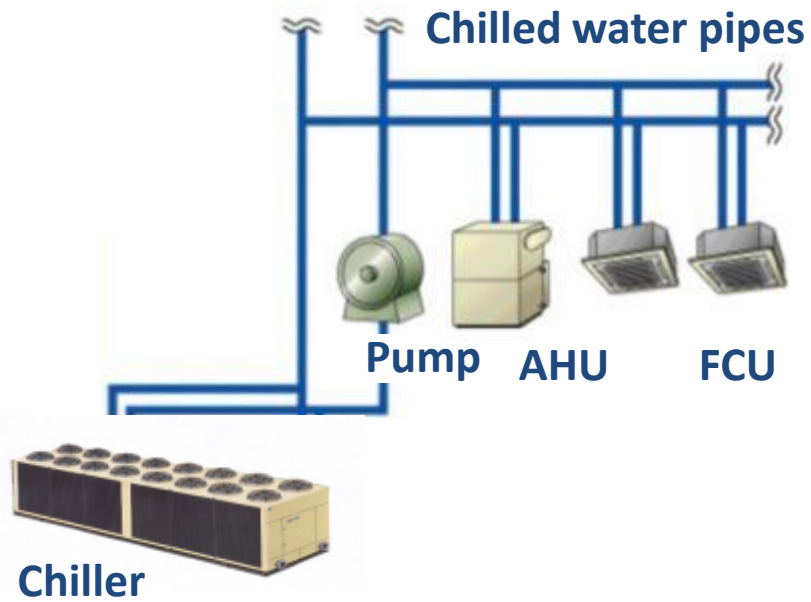



World AC market

World Air Conditioning Market by value by Product 2015, USD millions

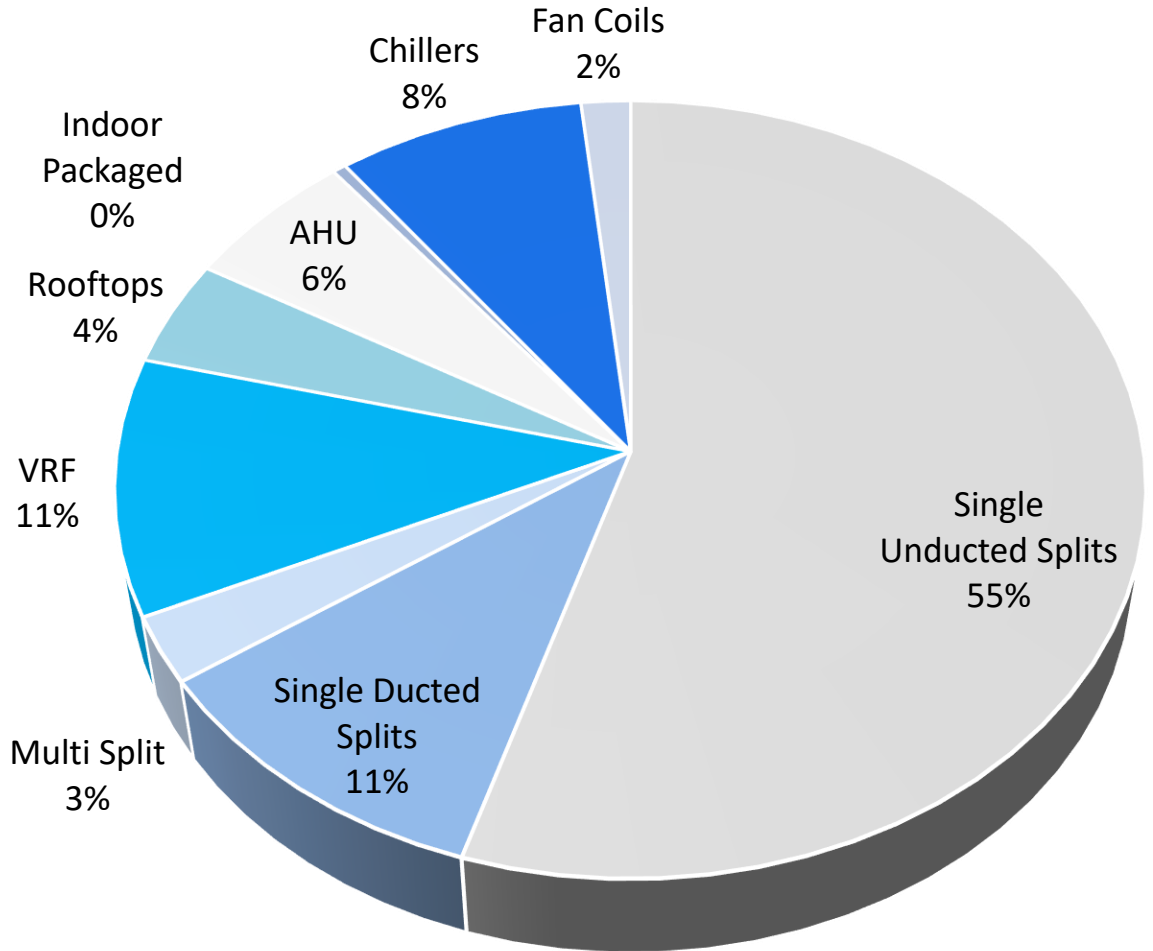

Product Category	Share
VRF	11% (9.7\$bn)
Chillers	8% (7.7 \$bn)
AHU & FCU	8% (7 \$ bn)
Ducted Splits (Including US ducted)	11% (9.6 \$bn)
Rooftops	4% (3.6 \$bn)
Total CAC	Around 40%, 38 billion

Source: The Building Services Research and Information Association (BSRIA)

World VRF market

World market for VRF from 2014 to 2020 in units (number of pieces)

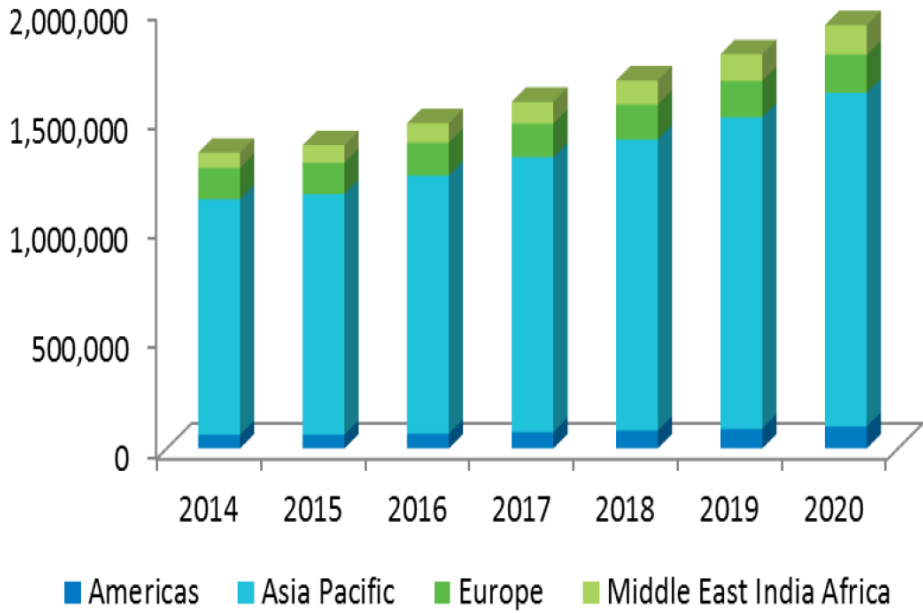

Top 10 countries in the world market VRF in 2015 by units (number of pieces)

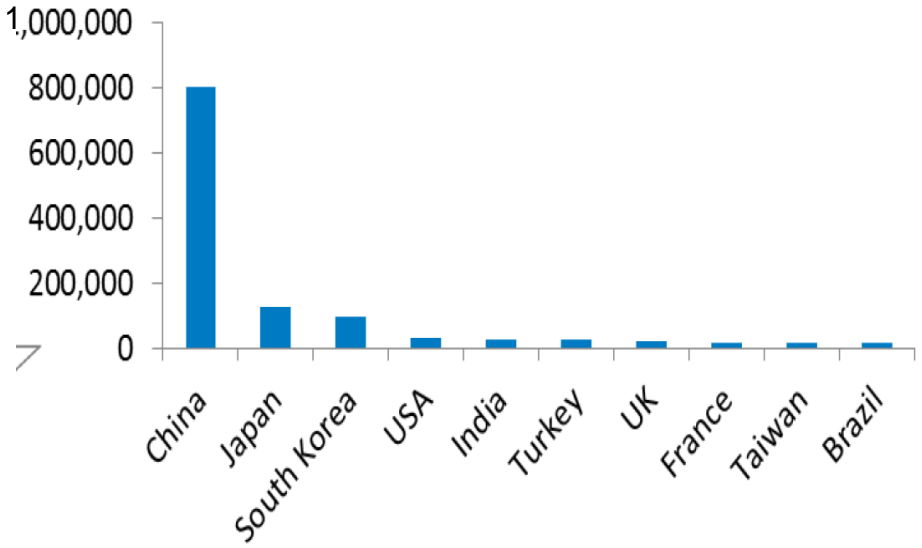

World chiller market

World Market for chillers from 2014 to 2020 in value (US\$m)

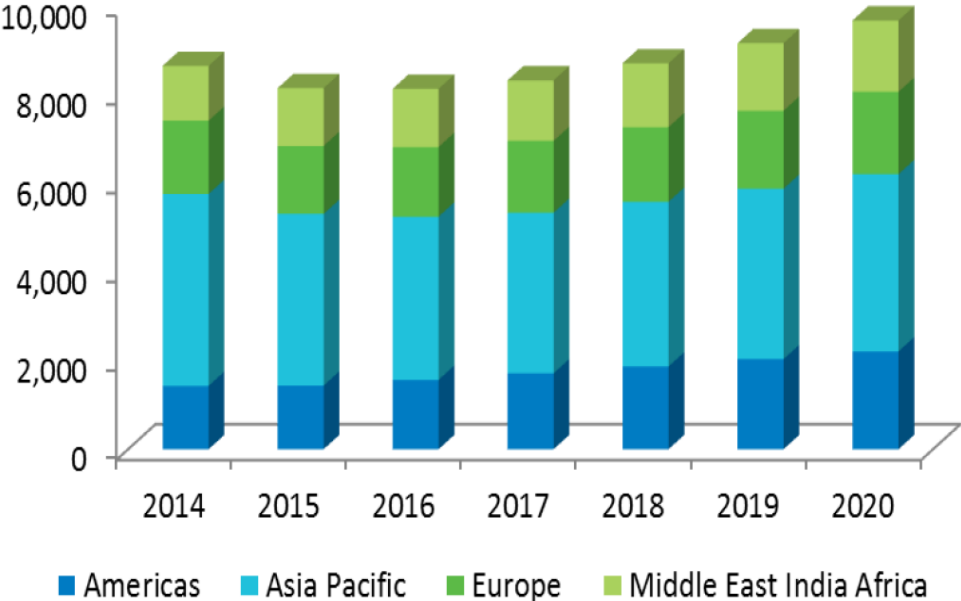

Top 10 countries in the world market for chillers in 2015 by value(US\$m)

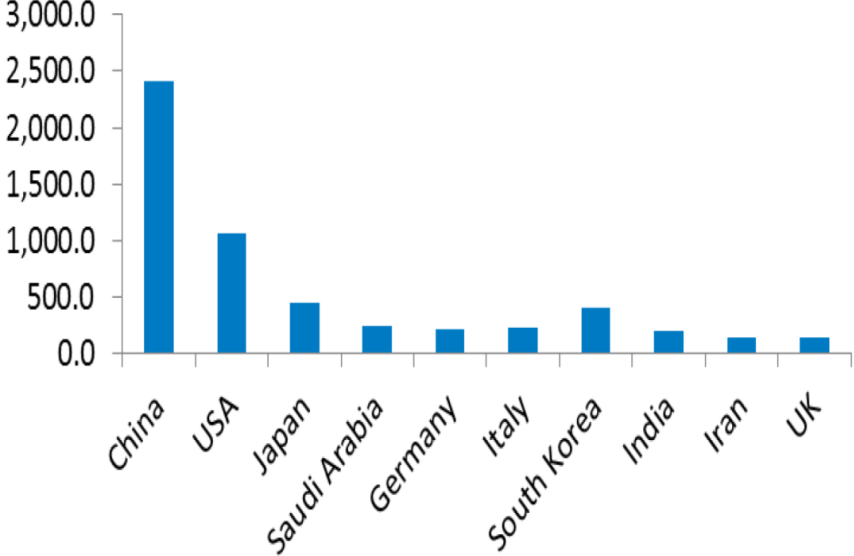

General Info

Benefits of VRF Systems

Benefits of Chiller Systems

Conclusions

VRF systems match demand precisely

- Output matches load requirement
- Energy savings
- High comfort

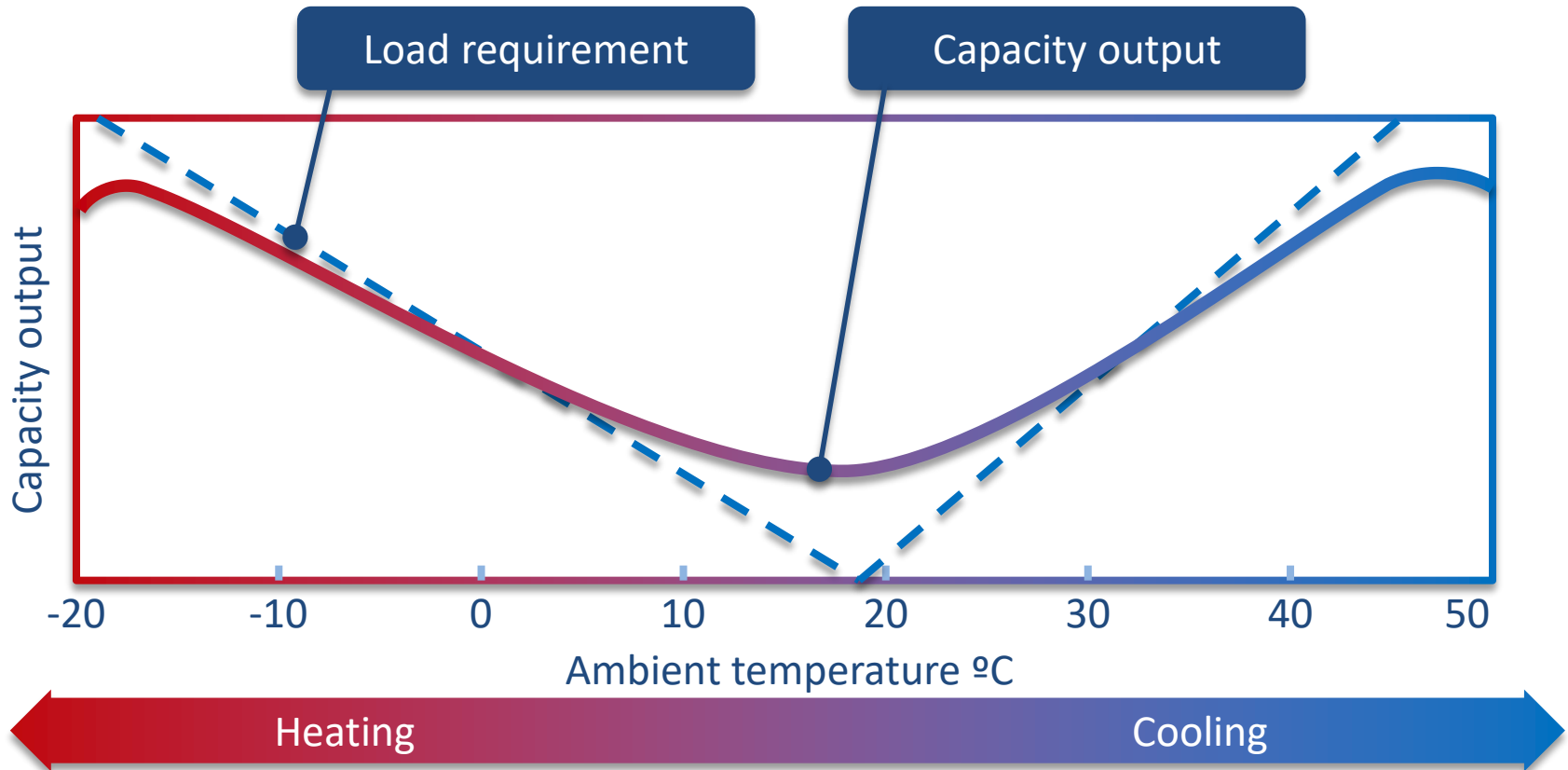

VRF systems match demand precisely

- Quick response to changing load requirements
- Tight temperature control

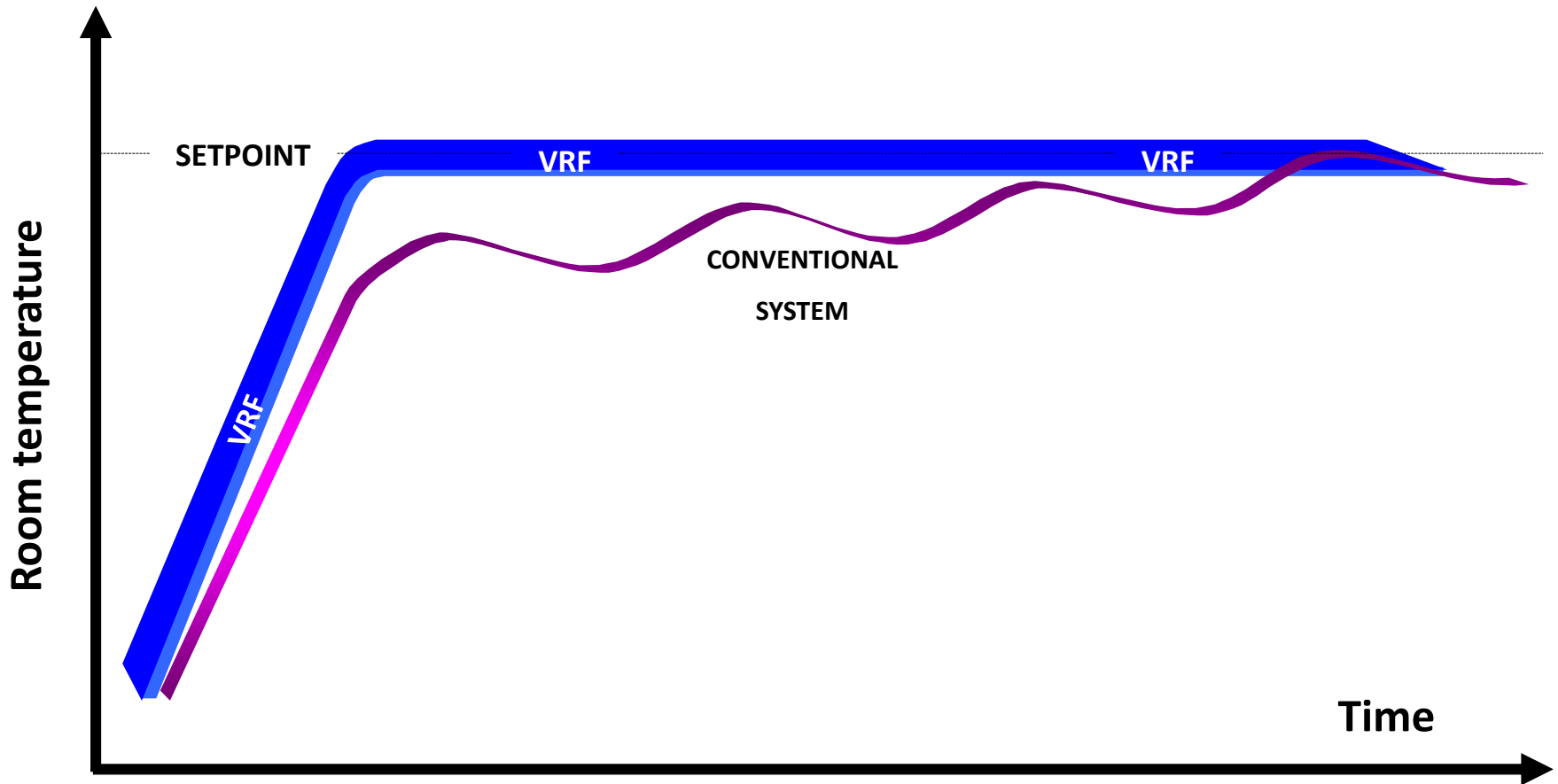

VRF systems match demand precisely

Compared to chiller system:

- VRF needs less time to startup and load to full capacity running
- Due to using water as second heat-transfer medium, chiller systems take time to sense and respond temperature changing
- VRF systems have lower starting currents due to having smaller capacity compressors and inverter starters



VRF systems need less space for installation

8 ton Capacity Example

Refrigerant R-410A	Water
$\varnothing 19.1 \text{ mm}$  $\varnothing 9.5 \text{ mm}$	$\varnothing 50 \text{ mm}$   $\varnothing 50 \text{ mm}$

Air

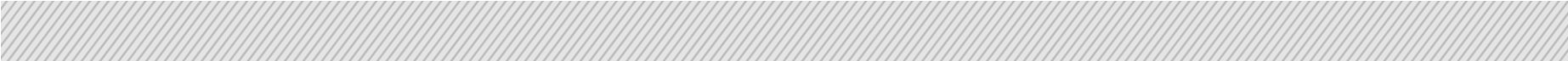
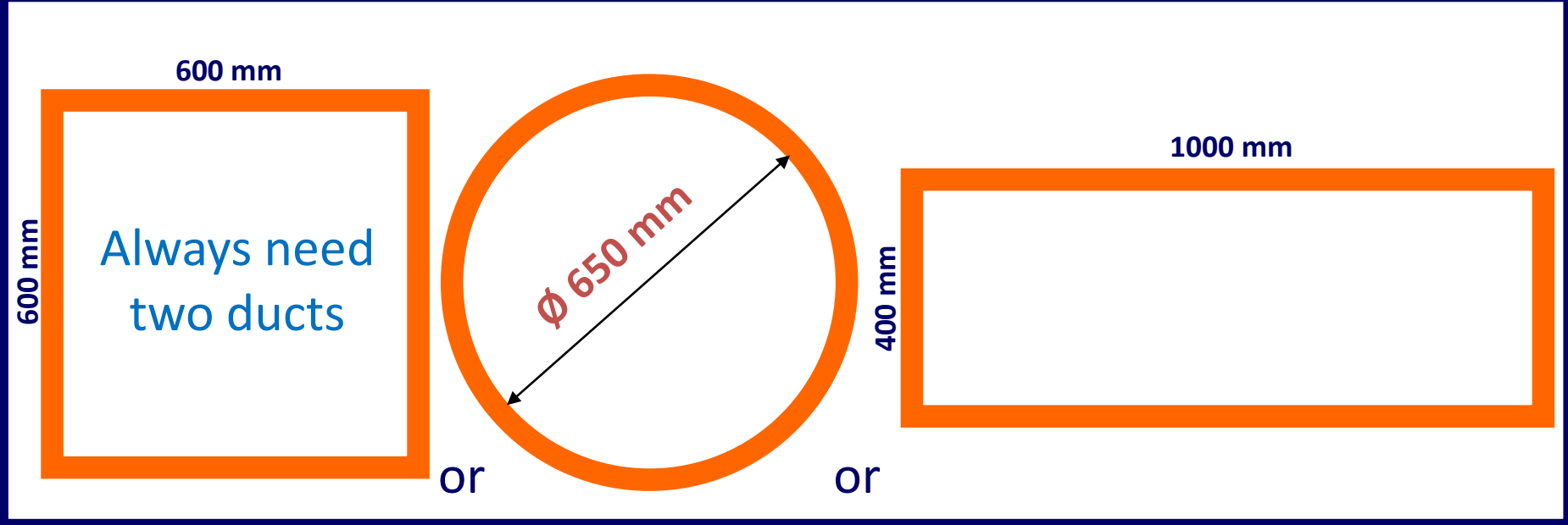

VRF systems need less space for installation

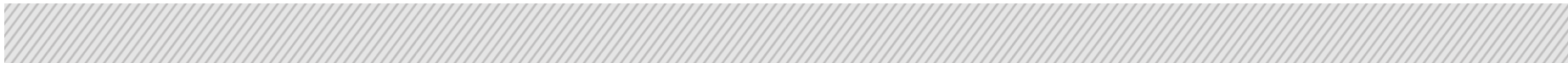
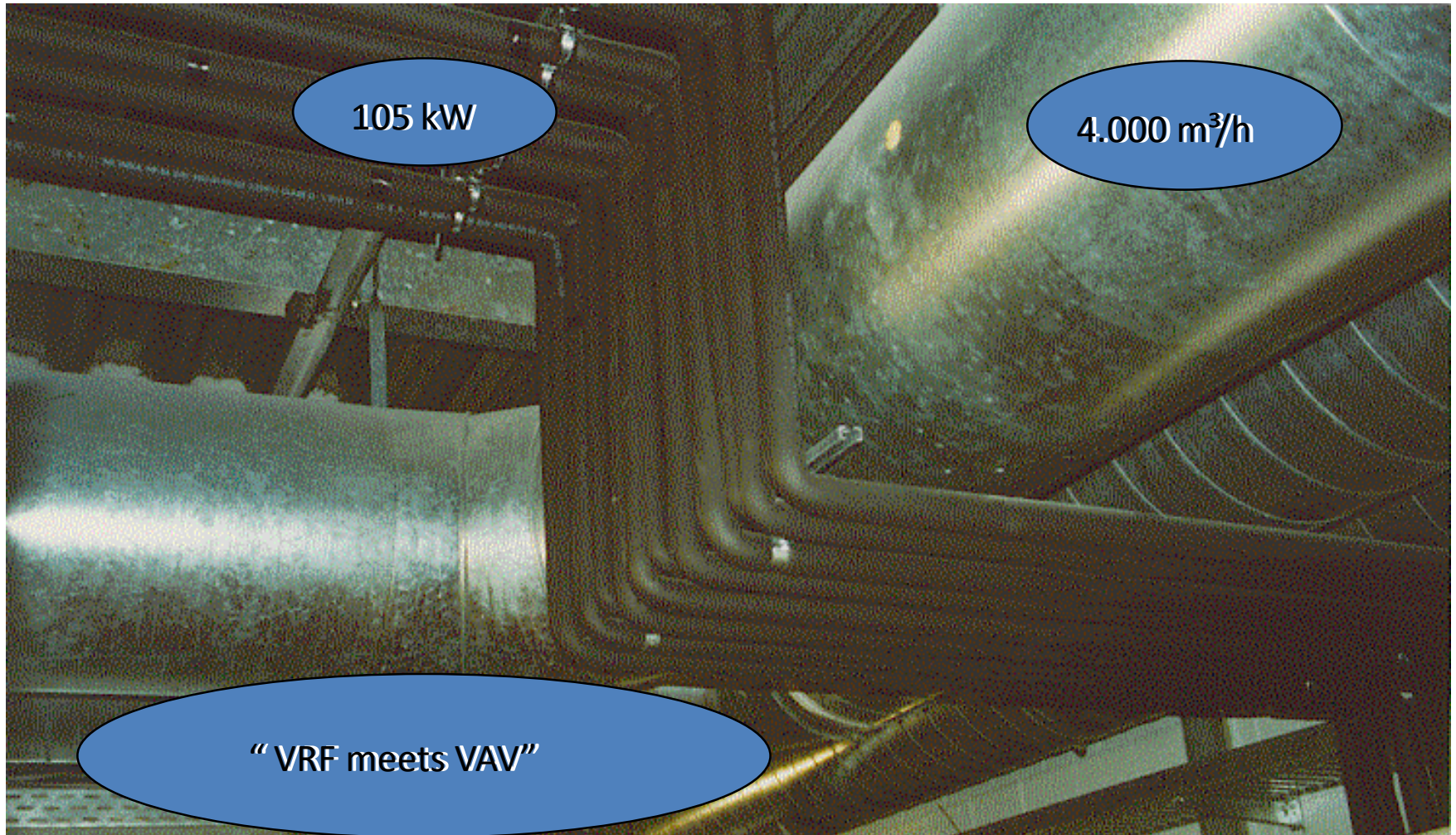

VRF systems need less space for installation

- VRF systems can be directly put on roofs or the ground
- Water-cooled chiller systems need special plant rooms



VRF systems are easier to design and install

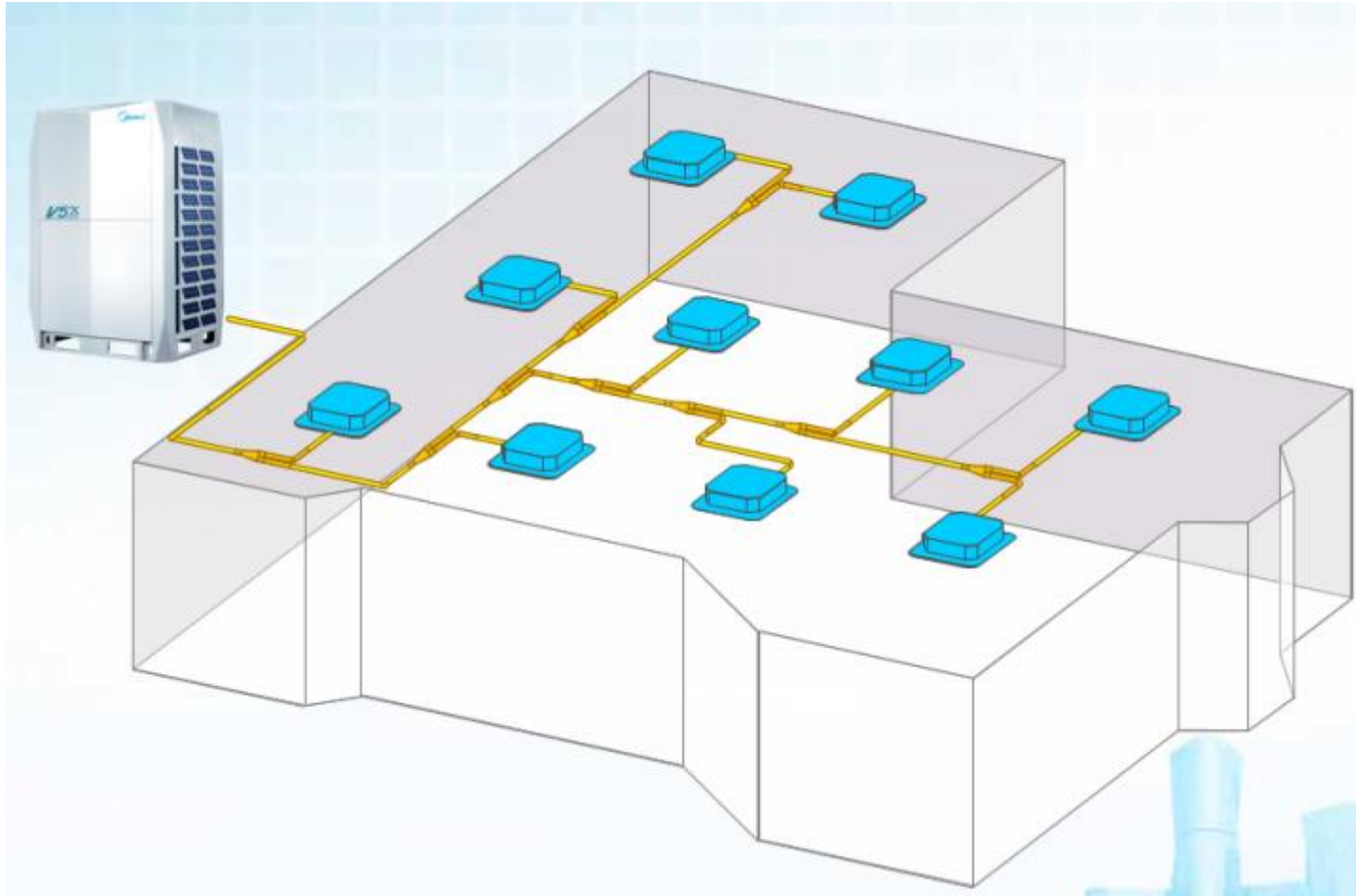

- Simple system: no pumps, no valves, no sensors needed
- One building's AC system can be separated into a few phases to install and test, and to extend if necessary

VRF systems are easier to design and install



PIPING above CHILLER



- Water pipes, water pumps, valves and other accessories make a much more complicated system

VRF system needs fewer resources

VRF

- One resource: electricity

Chillers

- Electricity
- Water
 - Scarce in some areas



VRF systems have lower noise levels

- VRF systems: Maximum 65dB(A)
- Chiller systems: Can easily go up to 85 dB(A) or even higher

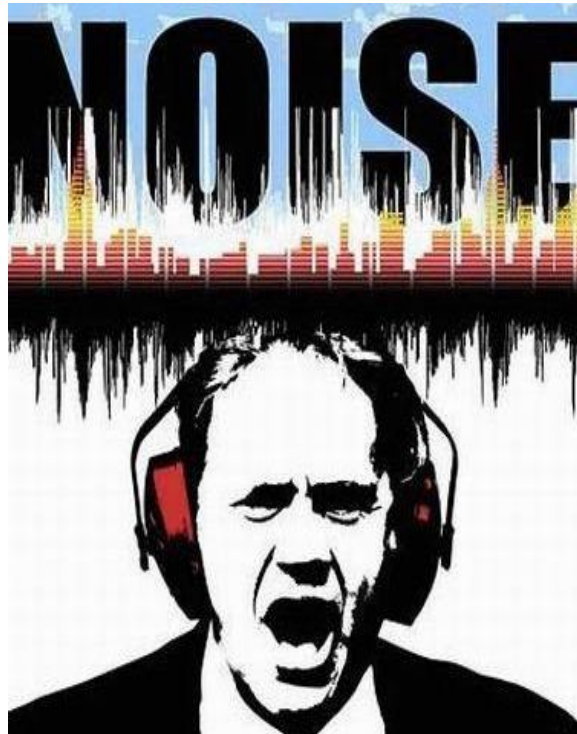

VRF systems are easier to operate and maintain

- VRF systems don't need a dedicated operator, end users can directly handle daily operation by themselves
- Most chiller systems need a dedicated technician to look after the plant room
- Every few months, chiller systems need to be serviced: clean water pipes, descale, replace lubrication oil



VRFs have simpler BMS systems

- VRFs have simpler BMS systems since all the indoor and outdoor units have their own PCBs - just connect communication wires and gateways to establish a BMS
- Chiller BMS systems are much more complicated to configure - many extra water sensors, pressure sensors, motorized valves required



General Info

Benefits of VRF System

Benefits of Chiller System

Conclusion

Chillers are especially suitable for large projects

- **Building:** Beijing International Airport T3
- **Construction area:** 370,000m²
- **Chillers installed:**
 - 4 x 1000RT Centrifugal (Offices)
 - 6 x 700RT Centrifugal (5-Star Hotel)
 - 2 x 500RT Centrifugal (Catering)
 - 1 x 350RT Screw

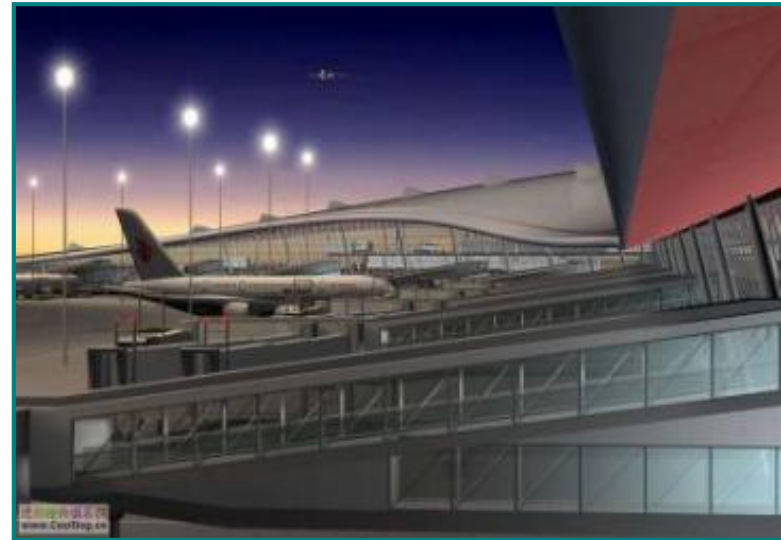

Chillers are especially suitable for large projects

- 1 plant room can cover an air-conditioning area as big as 500,000m²
- A VRF system would need around 1500 units, requiring a large space for the outdoor units
- Even if there is space to install so many outdoor units, piping length limitations would still be a big challenge for a VRF system



Chiller systems have excellent backup functions

- Chillers, pumps, cooling towers are all installed in parallel and can provide backup for each other

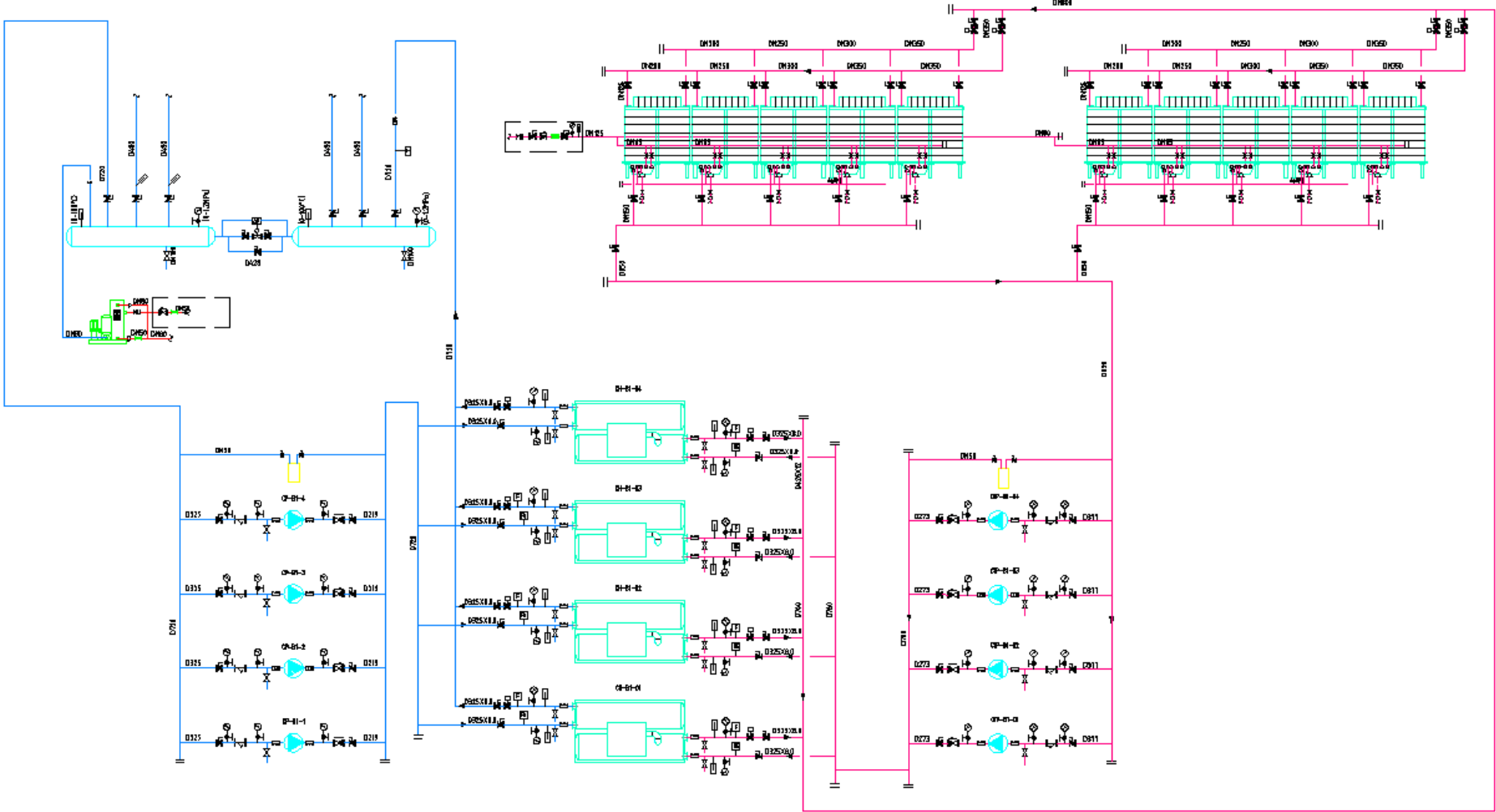

Chiller systems have better high-rise capabilities

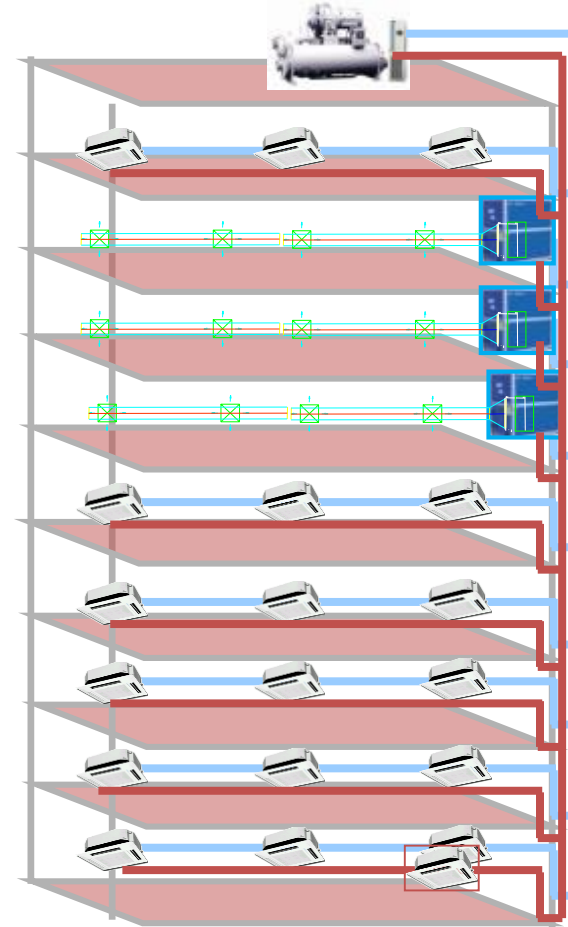

- For high-rise buildings, chiller systems have fewer limitations - only need to make sure the pressure inside the water pipes does not get too high
- Lower capacity losses

Chiller systems have better high-rise capabilities

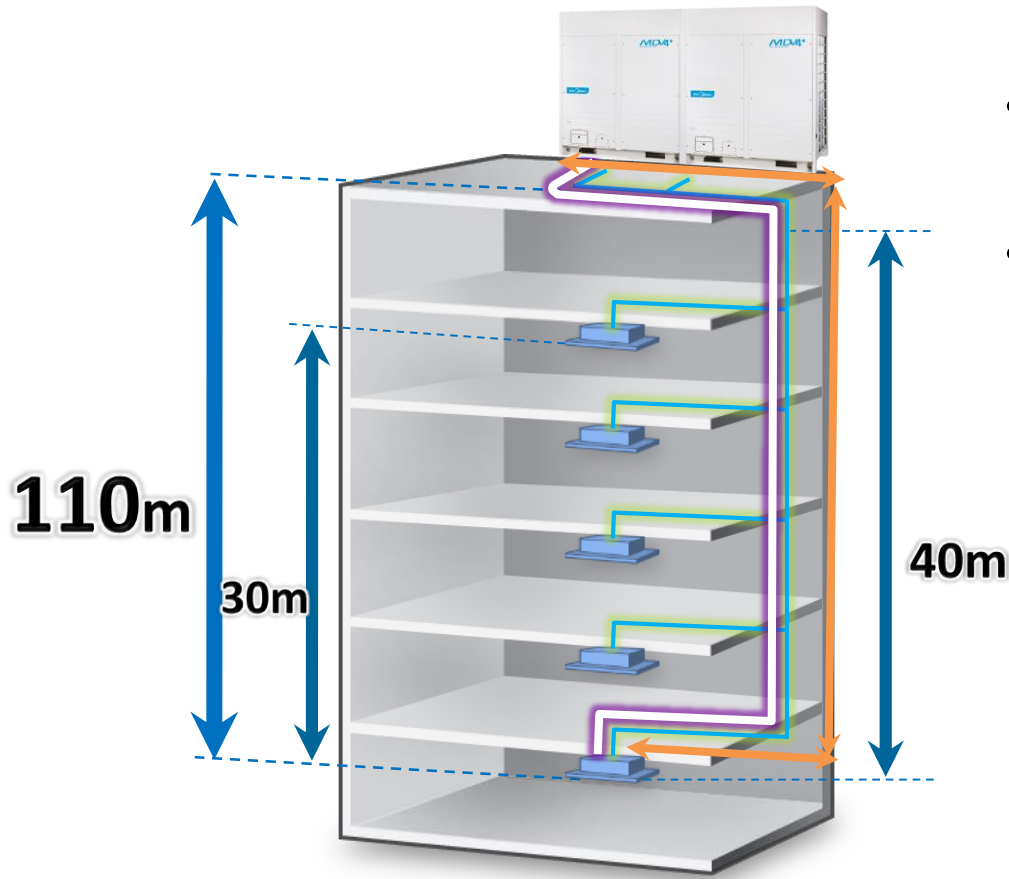

110m

30m

40m

Total pipe length: 1000m

Longest pipe length: 200m

- VRF systems have limitations on piping length and drop heights
- Even where the limitations are not a problem, noticeable capacity losses still need to be considered

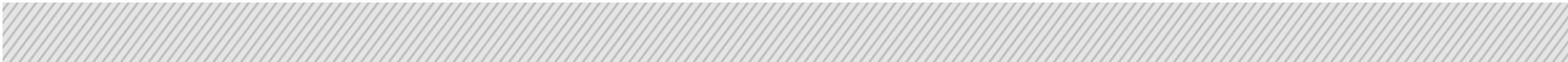

Other challenges for VRF systems

- Expensive copper piping
- Possibility of gas leakage
- Challenges in high ambient temperature zones
- Challenges in high dusty or sandy areas
- Oil reclaim
- Corrosion

General Info

Benefits of VRF Systems

Benefits of Chiller Systems

Conclusions

Conclusions

- Both VRF and chiller systems have their own benefits and limitations, so both have their own market share
- During last two decades, the VRF market has been growing rapidly. In the coming few years, it's share of the overall AC market is likely to increase further

Thank you

