



PCV1131

*Shaping air to your needs*

VRV indoor units combine with residential indoor units, all in one system



**VRV III** Single outdoor unit series  
—suitable for homes, offices, shops, and middle-sized buildings



**R-410A**

Cooling Only 50 Hz

# Meet the new *VRV III* single outdoor unit series, connectable to both VRV and residential indoor units

First launched in Japan in 1982, the Daikin VRV system has been embraced by world markets for nearly 30 years. Now, Daikin proudly introduces the new VRV III single outdoor unit series which enables a mixed combination of VRV indoor units and residential indoor units all in one system, opening the door to stylish and quiet indoor units.

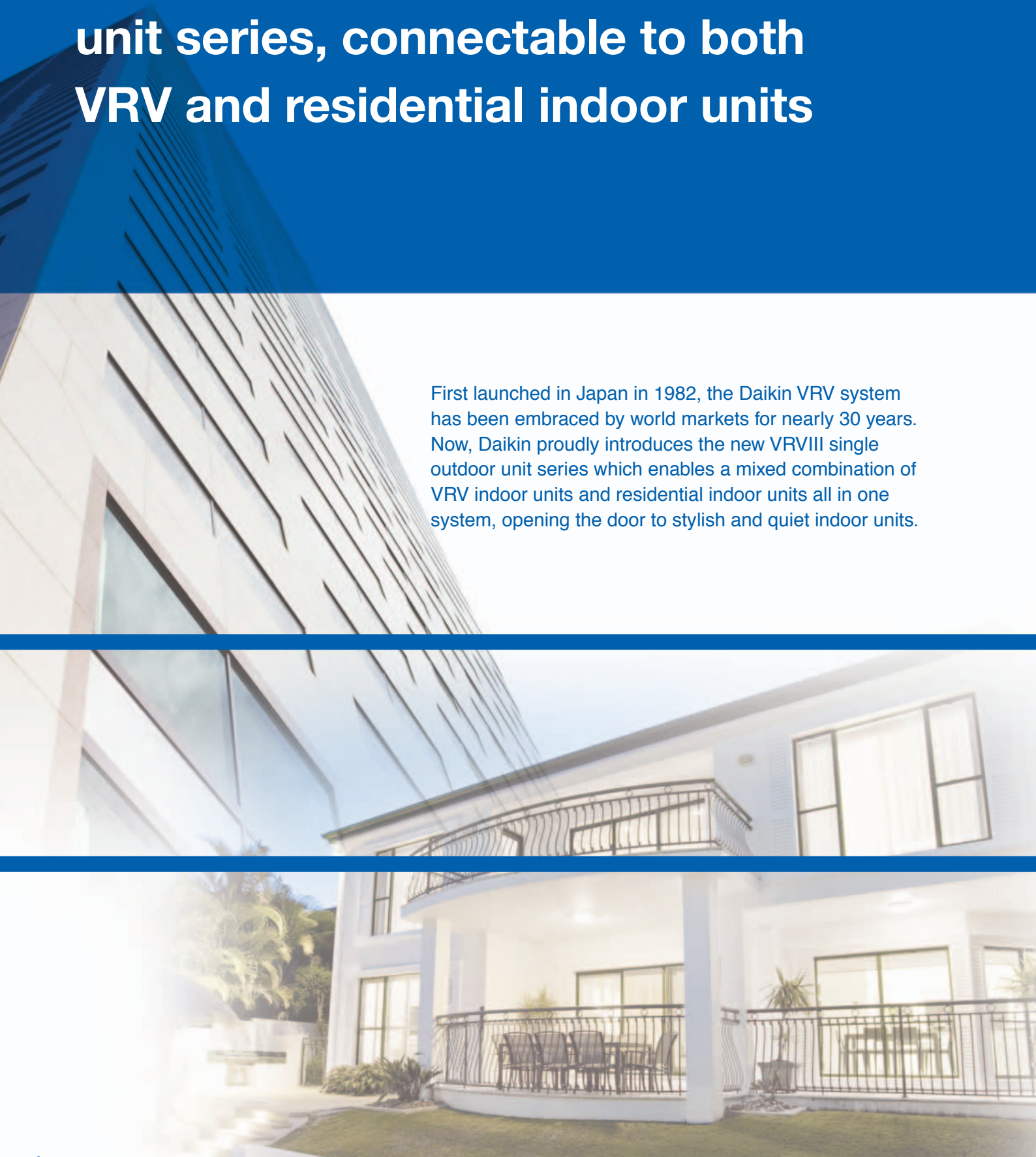

# Contents

Main Features.....page 3

Outdoor Unit Lineup.....page 4

Indoor Unit Lineup.....page 9

- V RV.....page 9
- Residential.....page 19

Specifications.....page 24

— Indoor units.....page 24

- V RV.....page 24
- Residential.....page 31

— BP units.....page 33

— Outdoor units.....page 34

Option List.....page 35

— Indoor units.....page 35

- V RV.....page 35
- Residential.....page 37

— BP units.....page 38

— Outdoor units.....page 38

Control Systems.....page 39



## Wide range of choices

### Indoor units

Indoor units can be selected from 2 lineups, both VRV and residential indoor units, to match rooms and preferences.



### VRV indoor units

15 types 73 models

Type	Model Name	Capacity Range	20	25	32	40	50	63	80	100	125	140	200	250
			0.8 HP	1 HP	1.25 HP	1.6 HP	2 HP	2.5 HP	3.2 HP	4 HP	5 HP	6 HP	8 HP	10 HP
			Capacity Index	20	25	31.25	40	50	62.5	80	100	125	140	200
Ceiling Mounted Cassette (Round Flow)	FXFQ-PVE		●	●	●	●	●	●	●	●	●			
Ceiling Mounted Cassette (Compact Multi Flow)	FXZQ-MVE		●	●	●	●	●							
Ceiling Mounted Cassette (Double Flow)	FXCQ-MVE		●	●	●	●	●	●	●		●			
Ceiling Mounted Cassette Corner	FXKQ-MAVE			●	●	●		●						
Slim Ceiling Mounted Duct	FXDQ-PBVE (with drain pump)		●	●	●									
	FXDQ-PBVET (without drain pump) (700 mm width type)		●	●	●									
	FXDQ-NBVE (with drain pump)					●	●	●						
	FXDQ-NBVET (without drain pump) (900/1,100 mm width type)					●	●	●						
Ceiling Mounted Duct	FXMQ-PVE		●	●	●	●	●	●	●	●	●	●		
	FXMQ-MAVE												●	●
Ceiling Suspended	FXHQ-MAVE				●			●		●				
Wall Mounted	FXAQ-MAVE		●	●	●	●	●	●						
Floor Standing	FXLQ-MAVE		●	●	●	●	●	●						
Concealed Floor Standing	FXNQ-MAVE		●	●	●	●	●	●						

Note: R-410A VRV system indoor units are not compatible with the R-22 VRV system.

### VRV indoor units connection unit series

Type	Model Name	Capacity Range	71	100	125	
			3 HP	4 HP	5 HP	
			Capacity Index	71	100	125
			Connection Unit	BEVQ71MAVE	BEVQ100MAVE	BEVQ125MAVE
Ceiling Suspended Cassette	FXUQ-MAV1		●	●	●	

Note: BEV units are necessary for Connection unit series indoor units. Refer to the Engineering Data Book for details.

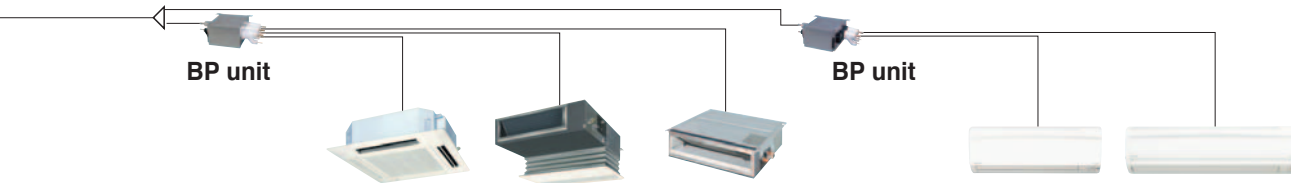

Residential indoor units

### Residential indoor units with connection to BP units

7 types 21 models

Type	Model Name	Rated Capacity	25	35	50	60	71
			Capacity Index	2.5 kW	3.5 kW	5.0 kW	6.0 kW
Ceiling Mounted Cassette	FCQ-BVE			●	●	●	●
Ceiling Mounted Cassette (Compact Multi Flow)	FFQ-BV1B		●	●	●	●	
Ceiling Mounted Built-in	FBQ-BV1					●	●
Slim Ceiling Mounted Duct	FDKS-EAVMB (700 mm width type)		●	●			
	FDKS-C(A)VMB (900/1,100 mm width type)		●	●	●	●	
Wall Mounted	FTKS-DVM		●	●			
	FTKS-FVM				●	●	●

Note: BP units are necessary for residential indoor units. Refer to page 33 for BP unit details.

### Outdoor units

The new VRVIII single outdoor unit series offers 6 models to select from, providing the power that suits your needs.

### VRV III single outdoor unit series



8, 10 HP



12, 14, 16, 18 HP

### Outdoor unit lineup

Model Name		RSXQ8PY1	RSXQ10PY1	RSXQ12PY1	RSXQ14PY1	RSXQ16PY1	RSXQ18PY1
Capacity Range	HP	8 HP	10 HP	12 HP	14 HP	16 HP	18 HP
	kW	22.4 kW	28.0 kW	33.5 kW	40.0 kW	45.0 kW	49.0 kW
Capacity Index		200	250	300	350	400	450

## Energy efficiency and quiet operation

Outdoor units use Daikin's unique scroll compressor to realise energy saving performance and quiet operation.

### High COPs

It has become essential for air conditioning manufacturers to develop systems that provide high energy savings. We at Daikin have made great efforts in this field, and the VRV8 delivers highly efficient performance, contributing to high energy savings.

#### Achieving a high COP

We have reached a high level of efficiency, thanks to advanced features such as the heat exchanger, the grille and the dual DC fans.

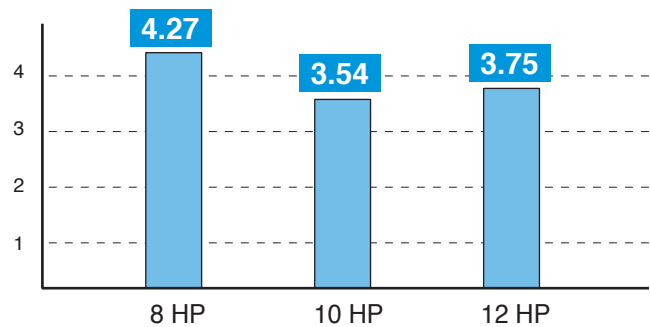

• Cooling operating conditions: Indoor temp. of 27°CDB, 19.0 °CWB, and outdoor temp. of 35°CDB.

### Nighttime quiet operation function

#### Operation sound level selectable from 3 steps for the night mode

##### Mode 1. Automatic mode

Set on the outdoor PCB. Time of maximum temperature is memorised. The low operating mode will initiate 8 hours<sup>\*1</sup> after the peak temperature in the daytime, and normal operation will resume 10 hours<sup>\*2</sup> after that. The operation sound level for the night mode can be selected from 55 dB(A) (Step 1), 50 dB(A) (Step 2) and 45 dB(A) (Step 3).

##### Mode 2. Manual mode

Starting time and ending time can be input. (An external control adaptor for outdoor unit, DTA104A53/61/62, and a locally obtained timer are necessary.)

##### Mode 3. Combined mode

Combinations of modes 1 and 2 can be used depending on your needs.

\*1. Initial setting. Can be selected from 6, 8 and 10 hours.

\*2. Initial setting. Can be selected from 8, 9 and 10 hours.

##### Mode 1. Automatic mode

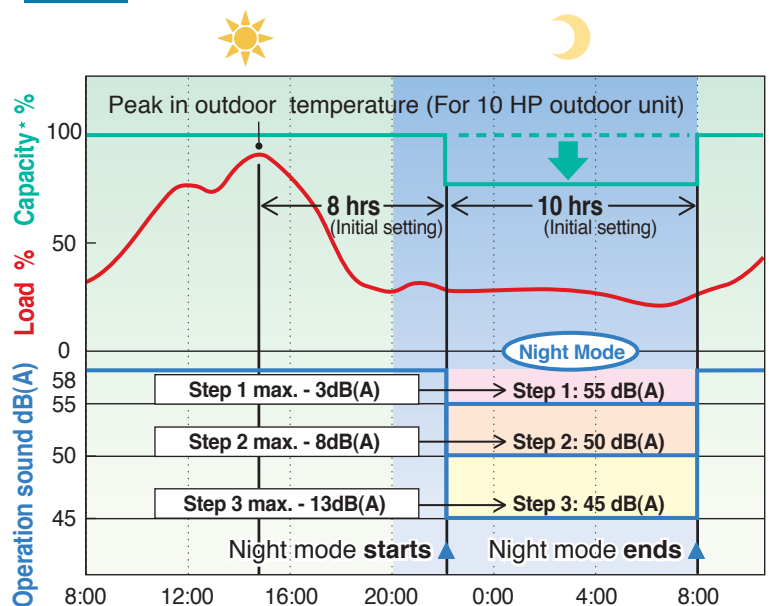

Notes: • This function is available in setting at site.

• The relationship of outdoor temperature (load) and time shown in the graph is just an example.

\* The capacity reduction rate differs depending on the operation sound level step selected.

# A collection of cutting-edge technologies realises efficient and quiet operation

## 1 High efficiency compressor

### Reluctance DC scroll compressor

Daikin's unique scroll compressor reduces heat loss, and is driven by a high efficiency motor to achieve significant energy savings.

High torque and efficiency is attained with the adoption of neodymium magnets.

### Powerful magnets

Use of neodymium magnets in the motor enables efficient generation of high torque.

Neodymium magnets are well known for their powerfulness compared to commonly used ferrite magnets.

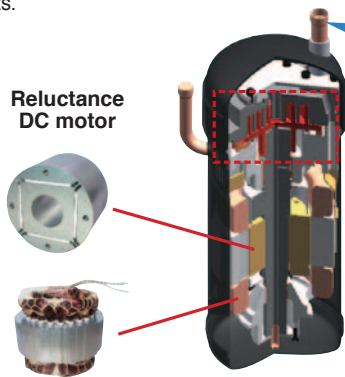

High-performance, low-noise scroll compressor operates at a fast rate. The speed increase has been achieved through advanced stress analysis for increased strength and utilisation of the advantages (oil film control) of the high thrust mechanism.\*

### \*High thrust mechanism

By introducing high pressure oil, the reactive force from the fixed scroll is added to the internal force, thereby reducing thrust losses. This results in improved efficiency and suppressed sound levels.

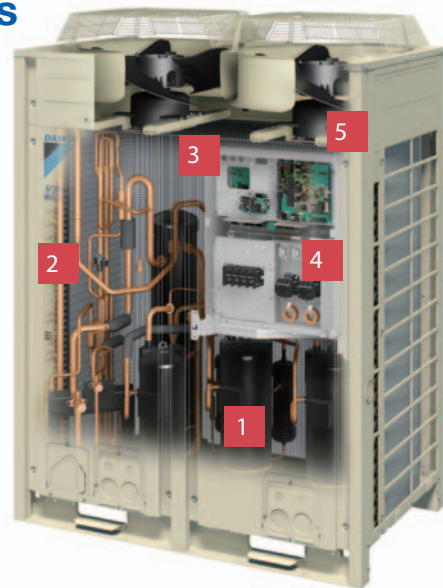

## 2 Heat exchanger

Thanks to an optimised e-Pass heat exchanger, heat change effectiveness has been increased, thus contributing to a high COP.

## 3 Compact aero box

Realises a compact casing by stacking the Inverter and control PCBs plus optimising the internal design to suit airflow speed. This achieves low noise and reduces the power required by the large-diameter fanned outdoor unit.

## 4 Smooth sine wave DC Inverter

By adoption of the Sine Wave, which smoothes the rotation of the motor, operation efficiency is improved sharply.

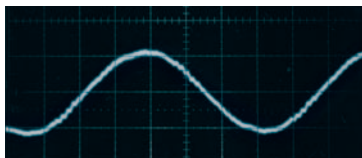

## 5 DC fan motor

- Efficiency improvement by approximately 40% especially at low speed.

### DC fan motor structure

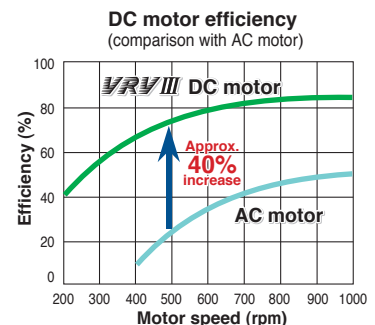

Note: Data are based on studies conducted under controlled conditions at a Daikin laboratory.

## Design flexibility

### Long piping length

Long piping length offers flexibility during installation.

Actual piping length  
Max. **100 m**

Total piping length  
Max. **250 m**

When only VRV indoor units are connected

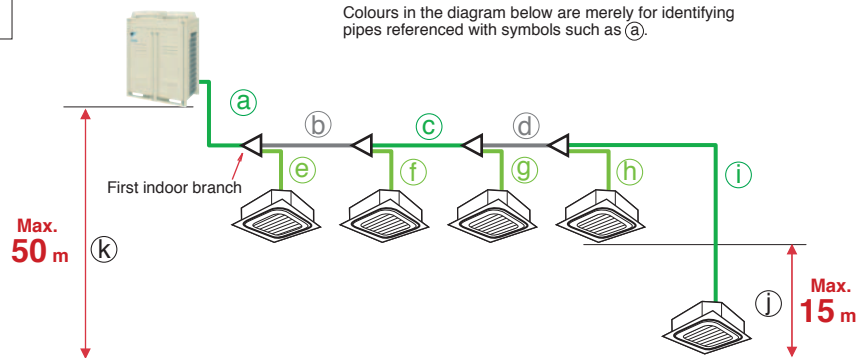

When only VRV indoor units are connected

	Actual piping length	Example	Equivalent piping length
<b>Maximum allowable piping length</b>	Refrigerant piping length	100 m	a+b+c+d+i
	Total piping length	250 m	a+b+c+d+e+f+g+h+i
	Between the first indoor branch and the farthest indoor unit	40 m	b+c+d+i
<b>Maximum allowable level difference</b>	Level Difference		Example
	Between the indoor units	15 m	j
	Between the outdoor unit and the indoor unit	If the outdoor unit is above. 50 m	k
		If the outdoor unit is below. 40 m	k

When a mixed combination of VRV and residential indoor units is connected

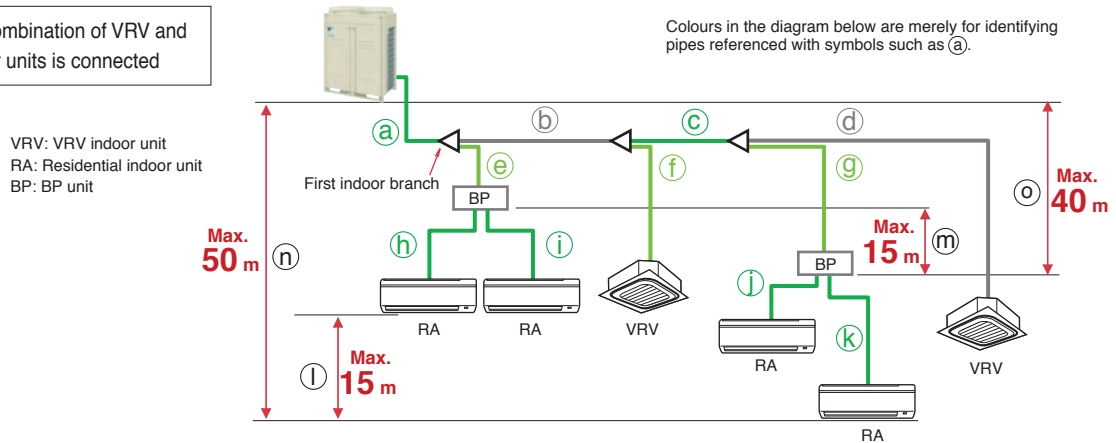

When a mixed combination of VRV and residential indoor units is connected or when only residential indoor units are connected

	Actual piping length	Example		
<b>Maximum allowable piping length</b>	Refrigerant piping length	100 m		
	Total piping length	250 m		
	Between BP unit and indoor unit	If indoor unit capacity index < 68.	2 m–15 m	
		If indoor unit capacity index is 68.	2 m–12 m	
		If indoor unit capacity index is 79.	2 m–8 m	
Between the first indoor branch and the farthest BP unit or between the first indoor branch and the farthest VRV indoor unit	50 m <sup>*1</sup>	b+c+g, b+c+d		
<b>Minimum allowable piping length</b>	Between outdoor unit and the first indoor branch	5 m		
<b>Maximum allowable level difference</b>	Level Difference		Example	
	Between the indoor units	15 m	l	
	Between BP units	15 m	m	
	Between the outdoor unit and the indoor unit	If the outdoor unit is above.	50 m	n
		If the outdoor unit is below.	40 m	n
Between the outdoor unit and the BP unit	40 m	o		

\*1. When the piping length exceeds 20 m, the size of the main pipes (the gas side and the liquid side) must be increased. Please refer to Engineering Data Book for details.



## As many as 29 indoor units can be connected

VRV VIII single outdoor unit series enables a mixed combination of VRV and residential indoor units by connecting BP units. As many as 29 indoor units can be connected, making this series a highly versatile system.

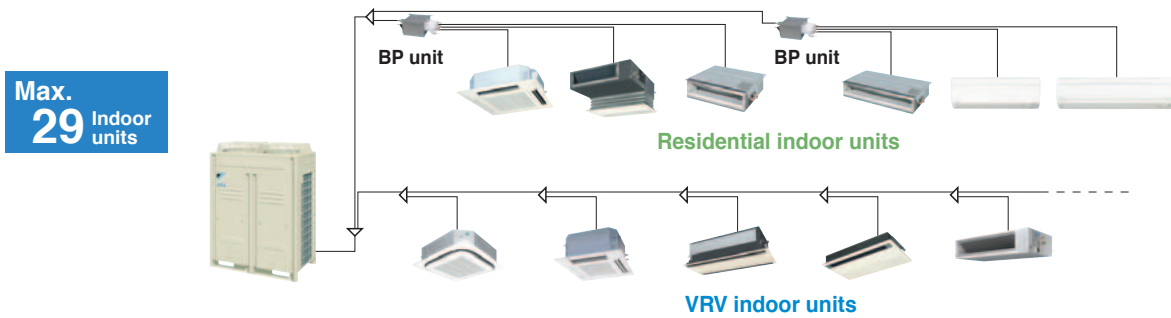

Note: Total capacity index of connectable indoor units must be 50%–130% of the capacity index of the outdoor unit. Refer to page 34 for the maximum number of connectable indoor units.

## High external static pressure of 78.4 Pa

High external static pressure has been achieved thanks to the fan grilles and the dual DC fans that reduce internal pressure loss. Daikin offers 78.4 Pa (8 mm H<sub>2</sub>O) external static pressure by field setting to meet the requirements for installation on each floor.

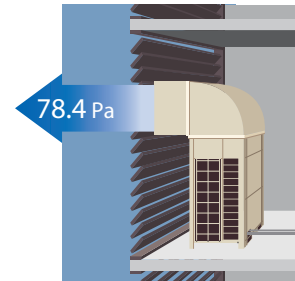

## Easy Installation

### Small and light, significantly reducing constraints during carry-in

Carry-in possible using ordinary elevators

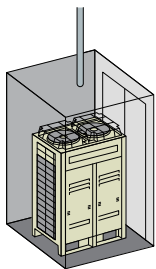

Easy belt suspension

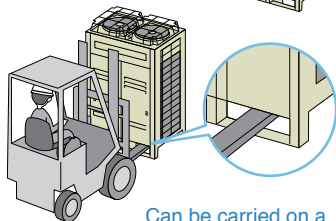
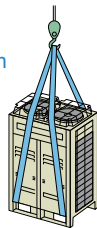

Can be carried on a fork-lift without a pallet

## High reliability

### Backup operation

If one of the multiple compressors malfunctions, the other compressors take over for emergency operation.\*1

If one compressor malfunctions...

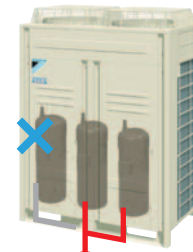

Emergency operation occurs.\*1

\*1. Possible only with single outdoor unit systems that are equipped with two or more compressors. Local setting of the outdoor unit is necessary.

## Automatic test operation

Simply press the test operation button and the unit performs an automatic system check, including wiring, shutoff valves, and sensors. The results are returned automatically after the check finishes.

## Less chances of refrigerant leakage

The shutoff valve connections for outdoor unit are brazed, meaning less chance of refrigerant leakage compared with flanged or flared connections.

### Ceiling Mounted Cassette (Round Flow) Type



FXFQ25P/FXFQ32P/FXFQ40P  
 FXFQ50P/FXFQ63P/FXFQ80P  
 FXFQ100P/FXFQ125P



\* Remote controllers are an optional accessory. Refer to page 39 for remote controller details.

## 360° airflow improves temperature distribution and offers a comfortable living environment.

- The industry's first\* Round Flow Ceiling Mounted Cassette type offers 360° airflow with improved temperature distribution.

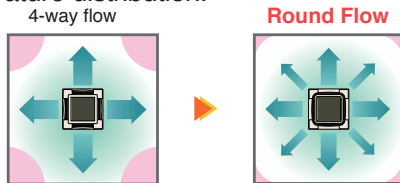

There are areas of uneven temperature.

There are much fewer areas of uneven temperature.

\* As of April 2004, the release date for Japan.

- All models are lighter than the conventional ones. Ex: Models FXFQ25P-50P are 4.5 kg lighter (reduced from 24 kg to 19.5 kg).

- Drain pump is equipped as standard accessory, and the lift height has been improved from 750 mm to 850 mm.

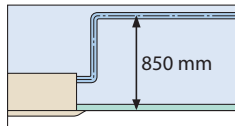

- A modern sophisticated decoration panel has been applied, with a panel surface that has been treated with a dirt-repellant coating.



- Condition after exposure to the smoke of 600 cigarettes in 1 m<sup>3</sup> enclosed space.

- Control of the airflow rate has been improved from 2-step to 3-step control.

- Low operation sound level (dB(A))

FXFQ-P	25/32	40	50	63	80	100	125
Sound level (HH/H/L)	30/28.5/27	31/29/27	32/29.5/27	34/31/28	36/33.5/31	43/37.5/32	44/39/34



- An antibacterial treatment that uses silver ions has been applied to the drain pan, preventing the growth of slime, mould and bacteria that cause blockages and odours.
- The horizontal louvres prevent dew condensation. Their non-flocking surfaces, which repel dirt, are easy to clean.
- The air filter has an anti-mould and antibacterial treatment that prevents the growth of mould generated from dust or moisture that may adhere to the filter.

- Example of airflow patterns:

360° airflow is available, as well as 2- to 4-way flows, so you can choose the most suitable airflow pattern depending on location or room layout.

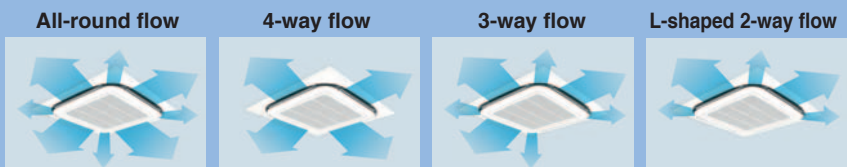

Note: Whatever the discharge direction, the same type of panel is used. If installing for other than all-round flow, an air discharge outlet sealing member (option) must be used to close each unused outlet.

## Ceiling Mounted Cassette (Compact Multi Flow) Type

**FXZQ20M / FXZQ25M / FXZQ32M  
FXZQ40M / FXZQ50M**



\* Remote controllers are an optional accessory. Refer to page 39 for remote controller details.

## Quiet, compact, and designed for user comfort

- Dimensions correspond with 600 mm × 600 mm architectural module ceiling design specifications.

- Low operation sound level

FXZQ-M		20/25	32	40	50
Sound level (H/L)	230 V	30/25	32/26	36/28	41/33
	240 V	32/26	34/28	37/29	42/35

(dB(A))

- Comfortable airflow

### 1 Wide discharge angle: 0° to 60°

- Auto swing

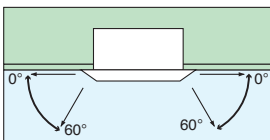

- Fixed angles: 5 levels

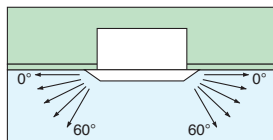

\*Angles can be also set on site to prevent drafts (0°-35°) or soiling of the ceiling (25°-60°), other than standard setting (0°-60°).

### 2 2-, 3-, and 4-way airflow patterns are available, enabling installation in the corner of a room.

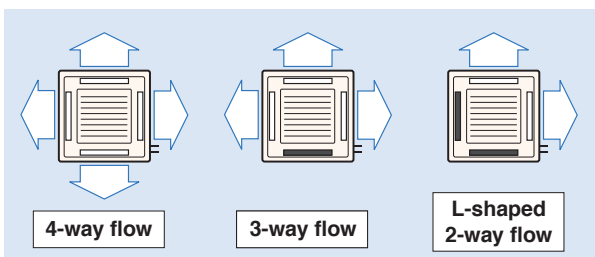

\*For 3-way or 2-way flow installation, the sealing member for air discharge outlet (option) must be used to close each unused outlet.



- Drain pump is equipped as standard accessory with 750 mm lift.

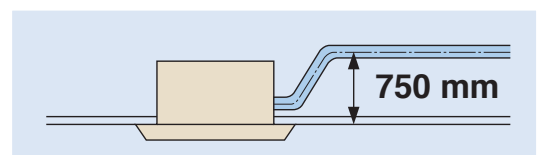

### Ceiling Mounted Cassette (Double Flow) Type

FXCQ20M / FXCQ25M / FXCQ32M  
 FXCQ40M / FXCQ50M / FXCQ63M  
 FXCQ80M / FXCQ125M



\* Remote controllers are an optional accessory. Refer to page 39 for remote controller details.

## Thin, lightweight, and easy to install in narrow ceiling spaces

- The thin unit (only 305 mm high) can be installed in a ceiling space as narrow as 350 mm. All models feature a compact design with a depth of only 600 mm.

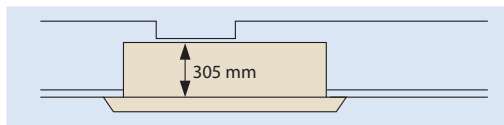

(When a high-efficiency filter is attached, the unit's height is 400 mm.)

- Low operation sound level (dB(A))

FXCQ-M	20	25/32	40/50	63	80	125	
Sound level (H/L)	220 V	32/27	34/28	34/29	37/32	39/34	44/38
	240 V	34/29	36/30	37/32	39/34	41/36	46/40

- Designed with higher airflow suitable for high ceiling application up to 3 metres.
- Providing 2 different settings of standard and ceiling soiling prevention, the auto swing mechanism realises even distribution of airflow and room temperature.
- Drain pump is equipped as standard accessory with 600 mm lift.

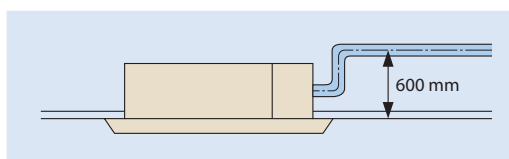

- Two types of optional high-efficiency filter are available (65% and 95%, colourimetric method).
- A long-life filter (maintenance free up to one year\*) is equipped as standard accessory.  
\* 8 hr/day, 25 day/month. For dust concentration of 0.15 mg/m<sup>3</sup>
- Major maintenance work can be performed by removing the panel. A flat-type suction grille and a detachable blade make cleaning easy.

## Ceiling Mounted Cassette Corner Type

**FXKQ25MA / FXKQ32MA  
FXKQ40MA / FXKQ63MA**



\* Remote controllers are an optional accessory. Refer to page 39 for remote controller details.

### Slim design for flexible installation

- Slim body needs only 220 mm space above the ceiling. If you use a panel spacer (option), the unit can be installed in the minimum space of 195 mm.

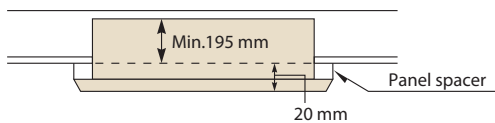

- Single-flow type allows effective air discharge from corner or from drop-ceiling.
- Drain pump is equipped as standard accessory with 500 mm lift.

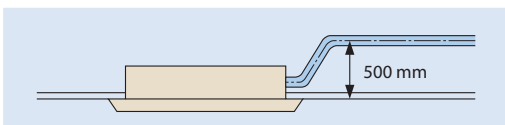

- Providing 3 different settings of standard, draft prevention and ceiling soiling prevention, the auto swing mechanism realises even distribution of airflow and room temperature.

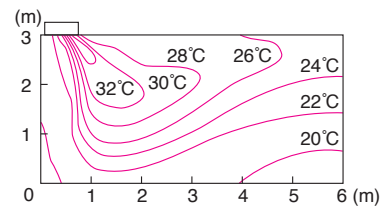

- Front discharge is possible with an air discharge unit (option), which allows the installation in the drop-ceiling or sagging wall.

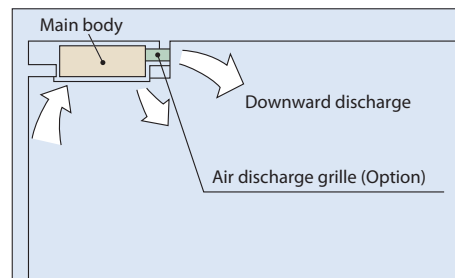

\*Set for front discharge using a suspended ceiling.

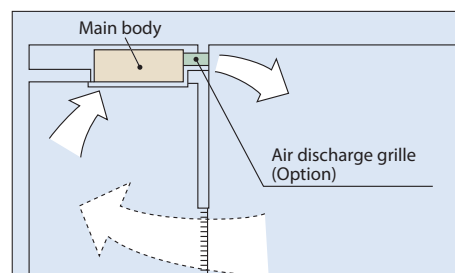

\*Downward discharge is shut off and air is blown straight out (front discharge).

- A long-life filter (maintenance free up to one year\*) is equipped as standard accessory.

\* 8 hr/day, 25 day/month. For dust concentration of 0.15 mg/m<sup>3</sup>



### Slim Ceiling Mounted Duct Type

## Slim design, quietness and static pressure switching

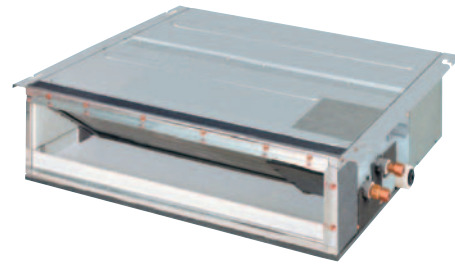

\* Remote controllers are an optional accessory. Refer to page 39 for remote controller details.

### Suited to use in drop-ceilings!

#### FXDQ20PB/FXDQ25PB/FXDQ32PB

- Only 700 mm in width and 23 kg in weight, this model is suitable to install in limited spaces like drop-ceilings in hotels.

Great for hotel use!

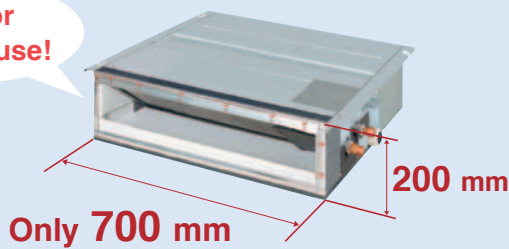

#### FXDQ40NB/FXDQ50NB/FXDQ63NB

- Only 200 mm in height, this model can be installed in rooms with as little as 240 mm depth between the drop-ceiling and ceiling slab.

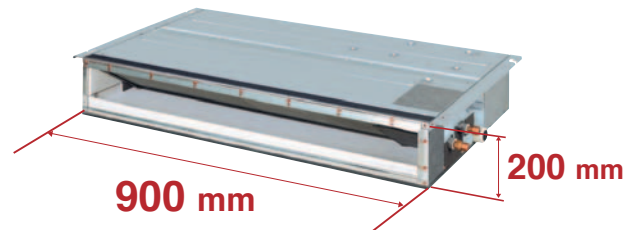

\* 1,100 mm in width for the FXDQ63NB model.

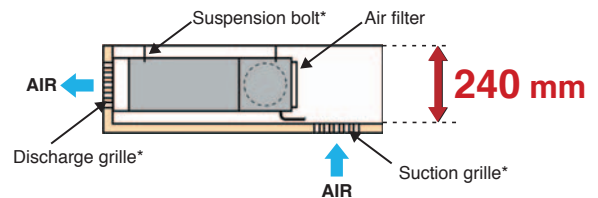

\* To be obtained locally

- Control of the airflow rate has been improved from 2-step to 3-step control.

- Low operation sound level

				(dB(A))
FXDQ-PB/NB	20/25/32	40	50	63
Sound level (HH/H/L)	33/31/29	34/32/30	35/33/31	36/34/32

\* The values of operation sound level represent those for rear-suction operation. Sound level values for bottom-suction operation can be obtained by adding 5 dB(A).

\* Values are based on the following conditions:

FXDQ-PB: external static pressure of 10 Pa; FXDQ-NB: external static pressure of 15 Pa.

- External static pressure selectable by remote controller switching make this indoor unit a very comfortable and flexible model.

10 Pa-30 Pa/factory set: 10 Pa for FXDQ-PB models.  
15 Pa-44 Pa/factory set: 15 Pa for FXDQ-NB models.

- FXDQ-PB and FXDQ-NB models are available in two types to suit different installation conditions.

FXDQ-PB/NBVE: with a drain pump (750 mm lift) as a standard accessory

FXDQ-PB/NBVET: without a drain pump

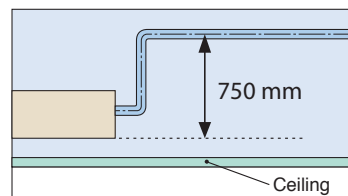

## Ceiling Mounted Duct Type

FXMQ20P/FXMQ25P/FXMQ32P  
 FXMQ40P/FXMQ50P/FXMQ63P  
 FXMQ80P/FXMQ100P/FXMQ125P  
 FXMQ140P



\* Remote controllers are an optional accessory. Refer to page 39 for remote controller details.

## Middle and high static pressure allows for flexible duct design

- A DC fan motor increases the external static pressure capacity range to include middle to high static pressures, increasing design flexibility.

30 Pa–100 Pa for FXMQ20P-32P

30 Pa–160 Pa for FXMQ40P

50 Pa–200 Pa for FXMQ50P-125P

50 Pa–140 Pa for FXMQ140P

- All models are only 300 mm in height, an improvement over the 390 mm height of conventional models. The weight of the FXMQ40P has been reduced from 44 kg to 28 kg.

- Drain pump is equipped as standard accessory with 700 mm lift.

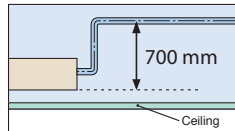

- Control of the airflow rate has been improved from 2-step to 3-step control.

- Low operation sound level (dB(A))

FXMQ-P	20/25	32	40	50	63	80/100	125	140
Sound level (HH/H/L)	33/31/29	34/32/30	39/37/35	41/39/37	42/40/38	43/41/39	44/42/40	46/45/43

- Energy-efficient

- The adopted DC fan motor is much more efficient than the conventional AC motor, yielding an approximate 20% decrease in energy consumption (FXMQ125P).



- Improved ease of installation

- The airflow rate can be controlled using a remote controller during test operation. With the conventional model, the airflow rate was controlled from the PC board. It is automatically adjusted to the range between approximately  $\pm 10\%$  of the rated HH tap airflow for FXMQ20P–125P.

- Improved ease of maintenance

- The drain pan can be detached for easy cleaning. An antibacterial treatment that uses silver ions has been applied to the drain pan, preventing the growth of slime, mould and bacteria that cause blockages and odours.

## FXMQ200MA/FXMQ250MA



- Simplified Static Pressure Control  
 External static pressure can be easily adjusted using a change-over switch inside the electrical box to meet the resistance in the duct system.

- Built-in Drain Pump (Option)

Housing the drain pump inside the unit reduces the space required for installation.

- Without drain pump

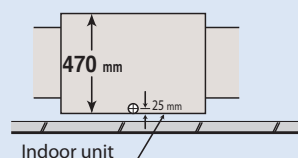

- With drain pump

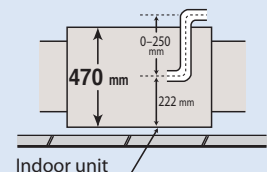

### Ceiling Suspended Type

**FXHQ32MA / FXHQ63MA  
FXHQ100MA**

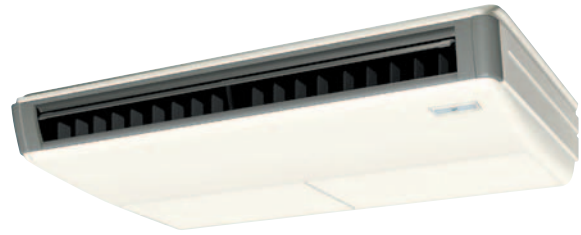

\* Remote controllers are an optional accessory. Refer to page 39 for remote controller details.

## Slim body with quiet and wide airflow

### ●Adoption of QUIET STREAM FAN

Uses the quiet stream fan and many more advanced technologies.

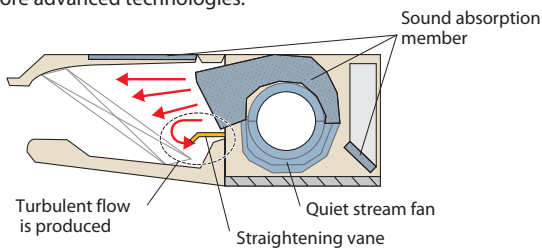

### ●Low operation sound level

	(dB(A))		
FXHQ-MA	32	63	100
Sound level (H/L)	36/31	39/34	45/37

### ●Installation is easy

- Drain pump kit (option) can be easily incorporated.

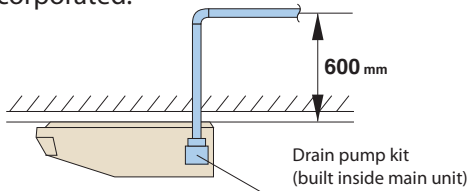

### ●Wide air discharge openings produce a spreading 100° airflow.

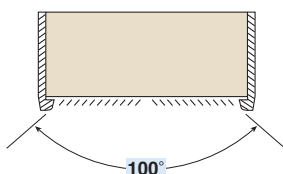

### ●Maintenance is easy

- Non-dew Flap with no implanted bristles

Bristle-free Flap minimises contamination and makes cleaning simpler.



Non-dew Flap

- Easy-to-clean flat design
- Maintenance is easier because everything can be performed from below the unit.
- A long-life filter (maintenance free up to one year\*) is equipped as standard accessory.

\* 8 hr/day, 25 day/month. For dust concentration of 0.15 mg/m<sup>3</sup>



## Wall Mounted Type

FXAQ20MA/FXAQ25MA  
FXAQ32MA/FXAQ40MA  
FXAQ50MA/FXAQ63MA



\* Remote controllers are an optional accessory. Refer to page 39 for remote controller details.

## Sophisticated design and compact casing harmonised with your interior décor

- Compact and stylish design that does not detract from the décor of the room.

- Low operation sound level (dB(A))

FXAQ-MA	20	25	32	40	50	63
Sound level (H/L)	35/29	36/29	37/29	39/34	42/36	46/39

- Drain pan and air filter can be kept clean by mildew-proof polystyrene.
- Washable grille, the front grille can be easily removed for washing.
- Auto-swing realises efficiency of air distribution. The louvre closes automatically when the unit stops.
- 5 steps of discharge angle can be set by remote controller.
- Discharge angle is automatically set at the same angle as the previous operation when restarting. (Initial setting: 10° for cooling)
- Flexible installation
  - Drain pipe can be fitted to from either left or right sides.



- Drain pump kit is available as optional accessory, which lifts the drain 1,000 mm from the bottom of the unit.

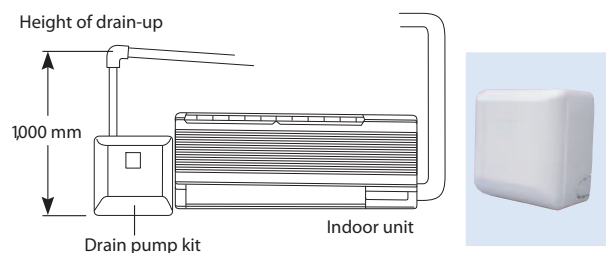

### Floor Standing Type

FXLQ20MA/FXLQ25MA  
 FXLQ32MA/FXLQ40MA  
 FXLQ50MA/FXLQ63MA



\* Remote controllers are an optional accessory. Refer to page 39 for remote controller details.

## Suitable for perimeter zone air conditioning

- Floor Standing types can be hung on the wall for easier cleaning. Running the piping from the back allows the unit to be hung on walls. Cleaning under the unit, where dust tends to accumulate, is considerably easier.
- The adoption of a fibre-less discharge grille featuring an original design to prevent condensation also helps prevent staining and makes cleaning easier.
- A long-life filter (maintenance free up to one year\*) is equipped as standard accessory.

\* 8 hr/day, 25 day/month. For dust concentration of 0.15 mg/m<sup>3</sup>

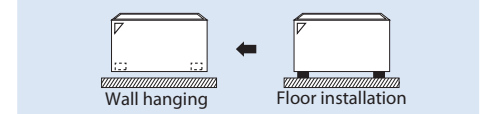

### Concealed Floor Standing Type

FXNQ20MA/FXNQ25MA  
 FXNQ32MA/FXNQ40MA  
 FXNQ50MA/FXNQ63MA



\* Remote controllers are an optional accessory. Refer to page 39 for remote controller details.

## Designed to be concealed in the perimeter skirting-wall

- The unit is concealed in skirting-wall of perimeter, that enables to create high class interior design.
- The connecting port faces downward, greatly facilitating on-site piping work.
- A long-life filter (maintenance free up to one year\*) is equipped as standard accessory.

\* 8 hr/day, 25 day/month. For dust concentration of 0.15 mg/m<sup>3</sup>

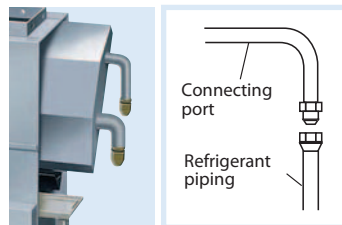

\* Applies also to Floor Standing type (FXLQ-MA).



## Connection unit series indoor units

### Ceiling Suspended Cassette Type

FXUQ71MA/FXUQ100MA  
FXUQ125MA



\* Remote controllers are an optional accessory. Refer to page 39 for remote controller details.

**This thin indoor unit achieves optimum air distribution, and can be installed without the need for ceiling cavity.**

- Depending on installation site requirements or room conditions, 2-way, 3-way and 4-way discharge patterns are available.

- 4-way airflow from the centre of the store.

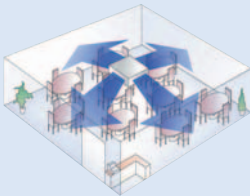

- The 3-way airflow can distribute comfortable air throughout the room.

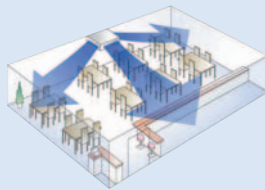

- Only one unit is needed to distribute comfortable air throughout an L-shaped store.

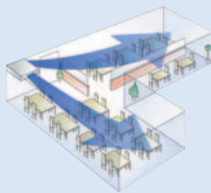

### Connection unit

Connection unit is the device for connecting above indoor unit to VRV III.

### BEVQ71MA/BEVQ100MA/BEVQ125MA

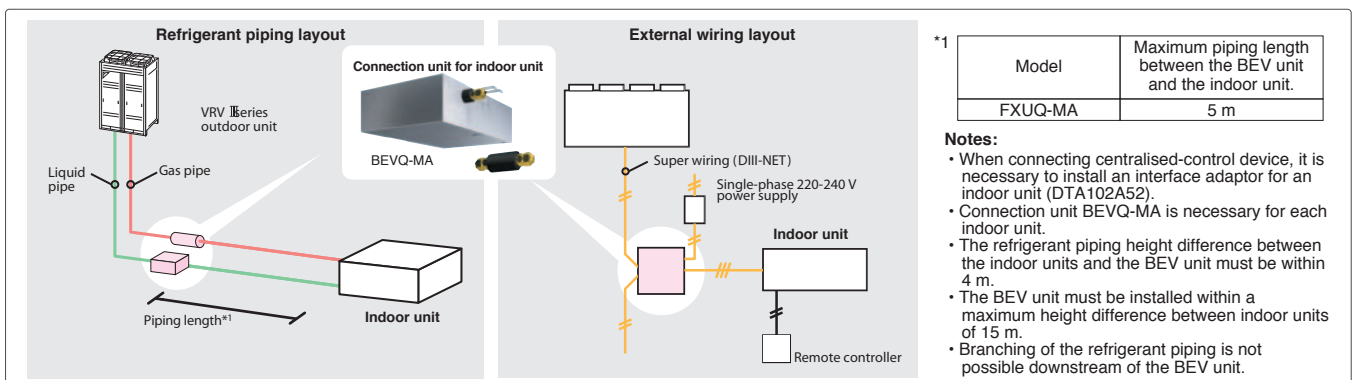

### Ceiling Mounted Cassette Type

#### FCQ35B/FCQ50B/FCQ60B/FCQ71B



Option  
Note: Remote controller cables not included. Cables should be obtained locally.



Option



Signal receiver unit  
Note: Wireless remote controllers and signal receiver units are sold as a set.

## Specially designed for false ceilings —for a smooth, modern interior finish

- All models feature a decoration panel with the same size and simple design in consideration of harmonised interior décor.

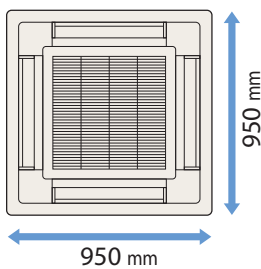

Same for all models

Decoration panel is optional

- The indoor units weigh only 24 kg and require an installation space with a height of just 245 mm.



- Low operation sound level

(H/L)

FCQ35B	FCQ50B	FCQ60B	FCQ71B
33/29 dB (A)	33/29 dB (A)	35/30 dB (A)	35/30 dB (A)

- Three convenient patterns for auto-swing operation

Standard

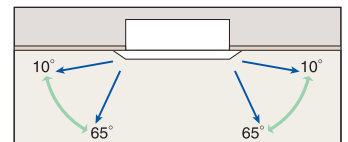

Draft prevention

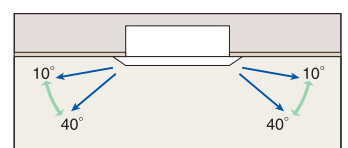

Soiling prevention

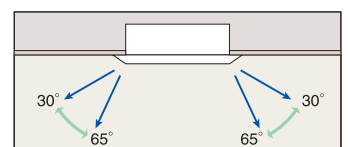

- Drain pump is equipped as standard with 750 mm.

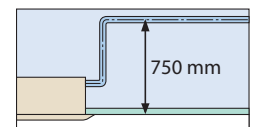

- These models have the power to provide a comfortable airflow even with a ceiling height of up to 3.8 m.

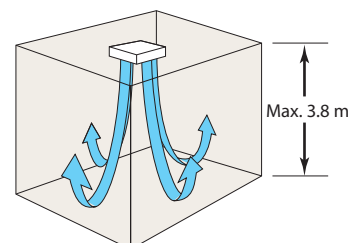

## Ceiling Mounted Cassette (Compact Multi Flow) Type

FFQ25B/FFQ35B/FFQ50B/FFQ60B



Option  
Note: Remote controller cables not included. Cables should be obtained locally.



Option



Signal receiver unit  
Note: Wireless remote controllers and signal receiver units are sold as a set.

## Quiet, compact, and designed for user comfort

- Designed to fit 600 mm wide ceiling grids

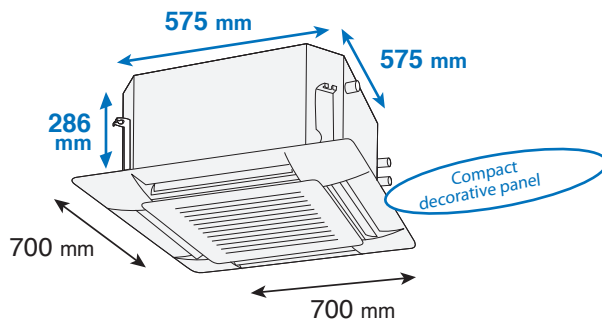

T-bar grid does not need to be cut.

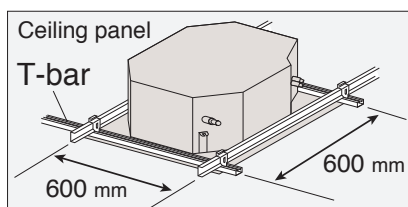

- Low draft performance is designed for your comfort.

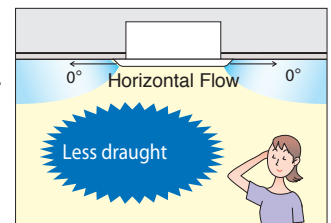

- Comfortable across all areas

Conditioned air is distributed evenly by Auto-swing operation. Adjustable airflow angle to suit all room conditions.

	AUTO-SWING	5 direction
<b>Standard setting</b>	Auto-swing between 0° and 60°	Settable to 5 different levels between 0° and 60°
<b>Draft prevention setting</b> (Set on site)	Auto-swing between 0° and 35°	Settable to 5 different levels between 0° and 35°
<b>Setting to prevent soiling of ceiling</b> (Set on site)	Auto-swing between 25° and 60°	Settable to 5 different levels between 25° and 60°

Note: Angles shown above are provided as a guide. They may differ depending on the installation site.

- Low operation sound level

(H/L)

FFQ25B	FFQ35B	FFQ50B	FFQ60B
29.5/24.5 dB (A)	32/25 dB (A)	36/27 dB (A)	41/32 dB (A)

- Drain pump is equipped as standard accessory with 750 mm lift.

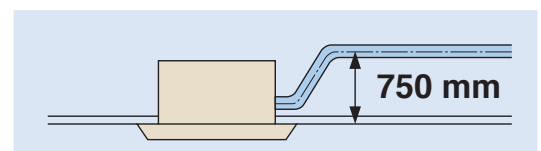

### Ceiling Mounted Built-in Type

#### FBQ60B/FBQ71B

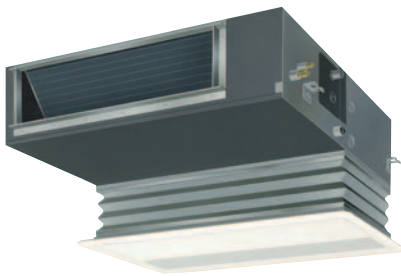

**Option**

Note: Remote controller cables not included. Cables should be obtained locally.



## Flexible air discharge unit to fit various forms of space

- The indoor unit can be installed in rooms with as little as 350 mm between the drop ceiling and ceiling slab. It also works with both flexible and ordinary ducts.

**Options**

- |                                       |                                |
|---------------------------------------|--------------------------------|
| ① Decorative panel                    | ⑦ High-performance filter      |
| ② Air discharge opening adaptor       | ⑧ Inspection panel             |
| ③ Canvas bellows and air intake panel | ⑨ Rear intake blocking pad     |
| ④ Flexible duct                       | ⑩ Air discharge opening flange |
| ⑤ Air discharge grille                | ⑪ Rear intake filter chamber   |
| ⑥ Air discharge chamber               | ⑫ Branch duct                  |
|                                       | ⑬ Low-draft filter chamber     |

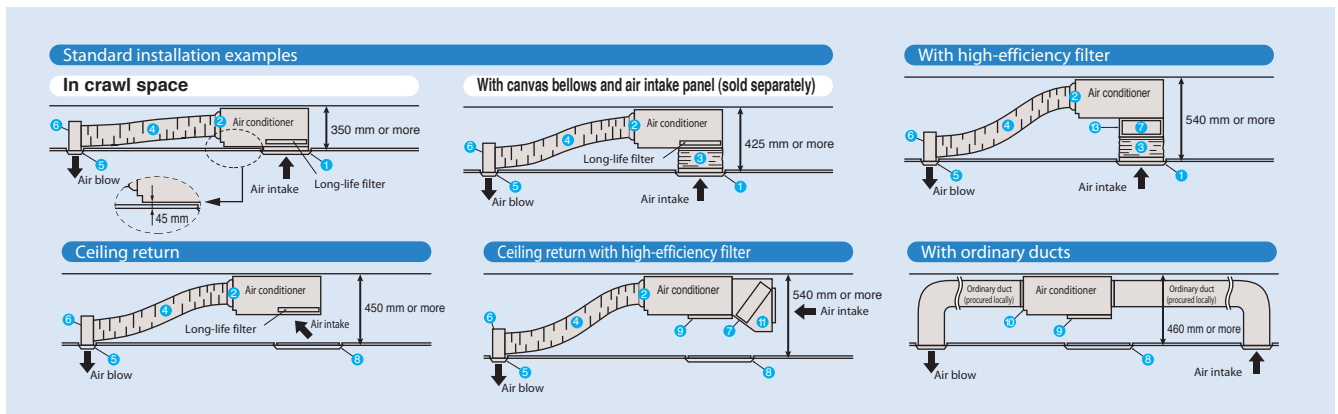

- To cope with the challenges of L-shaped or U-shaped spaces, it is possible to install the air discharge unit away from the main unit. This extends the possibilities for coping with human gathering patterns or sun lighting. At the same time, different types of architectural space can be kept comfortable.

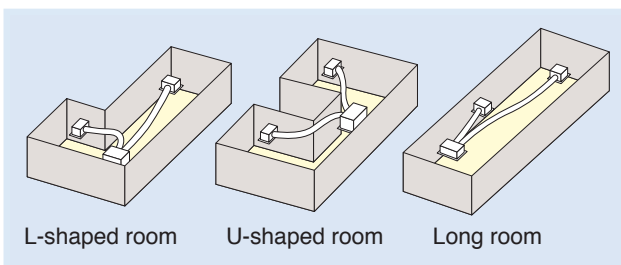

- Drain pump is equipped as standard accessory with 250 mm lift.

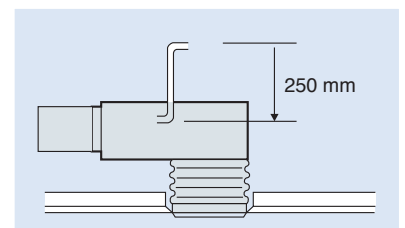

- Low operation sound level

(H/L)

FBQ60B	FBQ71B
41/35 dB (A)	41/35 dB (A)

## Slim Ceiling Mounted Duct Type

<700 mm width type>

**FDKS25EA/FDKS35EA**

<900/1,100 mm width type>

**FDKS25CA/FDKS35CA/FDKS50C/FDKS60C**

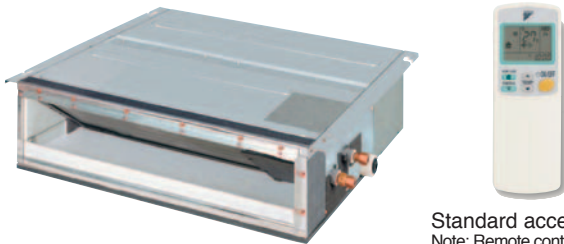

Standard accessory  
Note: Remote controllers other than the standard accessory wireless remote controller cannot be used.



## Slim and smooth design suits your shallow ceiling

- Models in the FDKS-EA series are only 700 mm in width and 21 kg in weight, so are easily installed in limited spaces. Just 200 mm in height, all models can be installed in rooms with as little as 240 mm depth between the drop ceiling and ceiling slab, making them ideal for even shallow ceilings.

Great for hotel use!

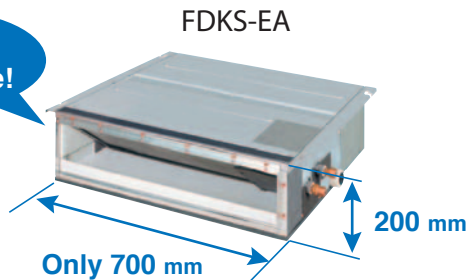

	FDKS25EA	FDKS35EA	FDKS25CA	FDKS35CA
Dimensions (H x W x D)	200 x 700 x 620 mm		200 x 900 x 620 mm	
Weight	21 kg		25 kg	
Airflow rate (H)	8.7 m <sup>3</sup> /min	9.5 m <sup>3</sup> /min	10 m <sup>3</sup> /min	
External static pressure	30 Pa		40 Pa	

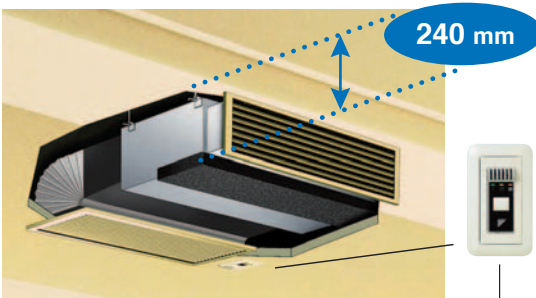

Signals from the wireless remote controller are transmitted to the signal receiver.

- Low operation sound level

(H/L/SL)

FDKS25	FDKS35	FDKS50	FDKS60
35/31/29 dB (A)	35/31/29 dB (A)	37/33/31 dB (A)	38/34/32 dB (A)

- Home Leave Operation prevents large rises or falls in the indoor temperature by continuing operation\* while you are sleeping or out of your home. This means that an air-conditioned welcome awaits when you wake or return. It also means that the indoor temperature can quickly return to your favourite comfort setting.

\* Home Leave Operation can be selected for any temperature from 18 to 32°C for cooling operation and 10 to 30°C for heating operation.

\* Home Leave Operation function must be set using the remote controller when going to sleep or leaving the house, and after waking up or returning home.

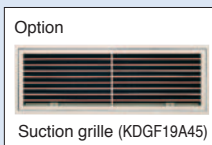
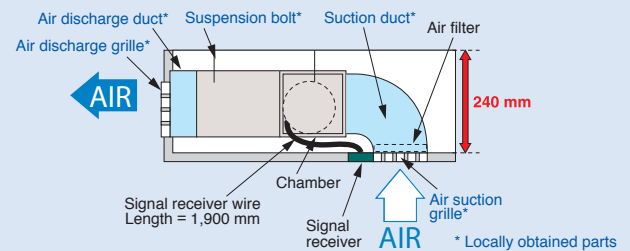

Notes:

- To prevent an increase in operation noise, avoid installing the air suction grille directly below the suction chamber.
- Grilles, piping connections, ducts, and installation parts should be obtained locally. Slim Ceiling Mounted Duct type FDKS models do not have drain-up pumps.
- The signal receiver unit must be located near the air suction inlet, because the unit includes a sensor that detects room temperature.



### Wall Mounted Type

#### FTKS25D/FTKS35D



Standard accessory\*

#### FTKS50F/FTKS60F/FTKS71F



Standard accessory\*



\* Remote controllers other than the standard accessory wireless remote controller cannot be used.

## Stylish flat panel harmonises with your interior décor

- Wall Mounted indoor units achieve quiet sound levels of 22 dB (A). (H/L/SL)

FTKS25D	FTKS35D	FTKS50F	FTKS60F	FTKS71F
37/25/22 dB (A)	39/26/23 dB (A)	43/34/31 dB (A)	45/36/33 dB (A)	46/37/34 dB (A)

- Intelligent Eye with its infrared sensor automatically controls air conditioner operation according to human movement in a room. When there is no movement, it adjusts the temperature by 2°C for energy savings.



When you are in the room



When you go out

- 3-D Airflow combines Vertical and Horizontal Auto-Swing to circulate air to every part of a room for uniform cooling of even large spaces.

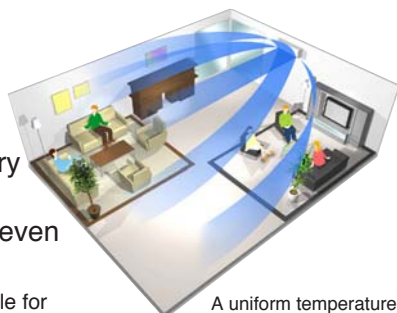

A uniform temperature is achieved throughout the entire room.

\* This function is available for FTKS50/60/71F.

- Titanium apatite is a photocatalytic material with high adsorption power. Titanium apatite also effectively adsorbs and decomposes bacteria across its entire surface. The photocatalyst is activated simply by exposure to light.

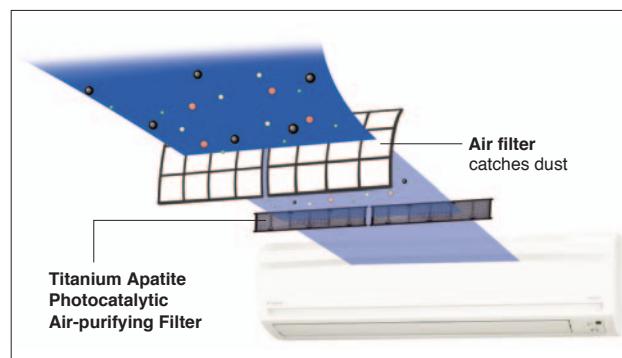

These filters are not medical devices. Benefits such as the adsorption and decomposition of bacteria are only effective for substances that are collected on and in direct contact with the Titanium Apatite Photocatalytic Air-Purifying Filter.

Bacteria Removal Test

Testing method: dropping method

Result certificate: No. 012553-1 and 012553-2

Testing organisation: Japan Spinners Inspecting Foundation

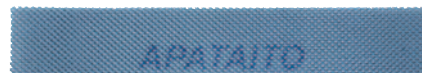



### Ceiling Mounted Cassette (Round Flow) Type



MODEL		FXFQ25PVE	FXFQ32PVE	FXFQ40PVE	FXFQ50PVE	FXFQ63PVE	FXFQ80PVE	FXFQ100PVE	FXFQ125PVE
Power supply		1-phase, 220-240 V/220 V, 50/60 Hz							
Cooling capacity	kcal/h (*1)	2,500	3,200	4,000	5,000	6,300	8,000	10,000	12,500
	Btu/h (*1)	9,900	12,600	16,000	19,800	24,900	31,700	39,600	49,500
	kW	(*1)	2.9	3.7	4.7	5.8	7.3	9.3	11.6
(*2)		2.8	3.6	4.5	5.6	7.1	9.0	11.2	14.0
Power consumption	kW	0.033	0.033	0.047	0.052	0.066	0.093	0.187	0.209
Casing		Galvanised steel plate							
Airflow rate (HH/H/L)	m <sup>3</sup> /min	13/11.5/10	13/11.5/10	15/13/11	16/13.5/11	19/16.5/13.5	21/18/15	32/26/20	33/28/22.5
	cfm	459/406/353	459/406/353	530/459/388	565/477/388	671/583/477	742/636/530	1,130/918/706	1,165/989/794
Sound level (HH/H/L)	dB(A)	30/28.5/27	30/28.5/27	31/29/27	32/29.5/27	34/31/28	36/33.5/31	43/37.5/32	44/39/34
Dimensions (HxWxD)	mm	246x840x840	246x840x840	246x840x840	246x840x840	246x840x840	246x840x840	288x840x840	288x840x840
Machine weight	kg	19.5	19.5	19.5	19.5	22	22	25	25
Piping connections	Liquid (Flare)	mm	φ 6.4	φ 6.4	φ 6.4	φ 6.4	φ 9.5	φ 9.5	φ 9.5
	Gas (Flare)		φ 12.7	φ 12.7	φ 12.7	φ 12.7	φ 15.9	φ 15.9	φ 15.9
	Drain		VP25 (External Dia, 32/Internal Dia, 25)						
Panel (Option)	Model	BYCP125K-W1							
	Colour	Fresh white							
	Dimensions (HxWxD)	mm	50x950x950	50x950x950	50x950x950	50x950x950	50x950x950	50x950x950	50x950x950
	Weight	kg	5.5	5.5	5.5	5.5	5.5	5.5	5.5

### Ceiling Mounted Cassette (Compact Multi Flow) Type

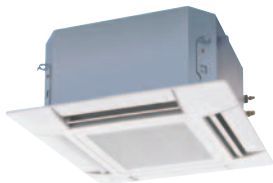

MODEL		FXZQ20MVE	FXZQ25MVE	FXZQ32MVE	FXZQ40MVE	FXZQ50MVE
Power supply		1-phase, 220-240 V/220 V, 50/60 Hz				
Cooling capacity	kcal/h (*1)	2,000	2,500	3,200	4,000	5,000
	Btu/h (*1)	7,800	9,900	12,600	16,000	19,800
	kW	(*1)	2.3	2.9	3.7	4.7
(*2)		2.2	2.8	3.6	4.5	5.6
Power consumption	kW	0.073	0.073	0.076	0.089	0.115
Casing		Galvanised steel plate				
Airflow rate (H/L)	m <sup>3</sup> /min	9/7	9/7	9.5/7.5	11/8	14/10
	cfm	318/247	318/247	335/265	388/282	493/353
Sound level (H/L)	230 V-240 V dB(A)	30/25-32/26	30/25-32/26	32/26-34/28	36/28-37/29	41/33-42/35
Dimensions (HxWxD)	mm	286x575x575				
Machine weight	kg	18				
Piping connections	Liquid (Flare)	mm	φ 6.4	φ 6.4	φ 6.4	φ 6.4
	Gas (Flare)		φ 12.7	φ 12.7	φ 12.7	φ 12.7
	Drain		VP20 (External Dia, 26/Internal Dia, 20)			
Panel (Option)	Model	BYFQ60B8W1				
	Colour	White (6.5Y9.5/0.5)				
	Dimensions (HxWxD)	mm	55x700x700	55x700x700	55x700x700	55x700x700
	Weight	kg	2.7	2.7	2.7	2.7

Note: Specifications are based on the following conditions;

- Cooling: (\*1) Indoor temp. of 27°CDB, 19.5°CWB, and outdoor temp. of 35°CDB. (\*2) Indoor temp. of 27°CDB, 19°CWB, and outdoor temp. of 35°CDB.
- Equivalent piping length: 7.5 m
- Level difference: 0 m
- Capacity of indoor unit is only for reference. Actual capacity of indoor unit is based on the total capacity index. (See Engineering Data Book for details.)
- Sound level: Anechoic chamber conversion value, measured at a point 1.5 m downward from the unit centre.  
During actual operation, these values are normally somewhat higher as a result of ambient conditions.

### Ceiling Mounted Cassette (Double Flow) Type



MODEL		FXCQ20MVE	FXCQ25MVE	FXCQ32MVE	FXCQ40MVE	FXCQ50MVE	FXCQ63MVE	FXCQ80MVE	FXCQ125MVE	
Power supply		1-phase, 220-240 V/220 V, 50/60 Hz								
Cooling capacity	kcal/h (*1)	2,000	2,500	3,200	4,000	5,000	6,300	8,000	12,500	
	Btu/h (*1)	7,800	9,900	12,600	16,000	19,800	24,900	31,700	49,500	
	kW	(*1)	2.3	2.9	3.7	4.7	5.8	7.3	9.3	14.5
(*2)		2.2	2.8	3.6	4.5	5.6	7.1	9.0	14.0	
Power consumption	kW	0.077	0.092	0.092	0.130	0.130	0.161	0.209	0.256	
Casing		Galvanised steel plate								
Airflow rate (H/L)	m <sup>3</sup> /min	7/5	9/6.5	9/6.5	12/9	12/9	16.5/13	26/21	33/25	
	cfm	247/177	318/230	318/230	424/318	424/318	582/459	918/741	1,165/883	
Sound level (H/L)	220 V	dB(A)	32/27	34/28	34/28	34/29	34/29	37/32	39/34	44/38
	240 V		34/29	36/30	36/30	37/32	37/32	39/34	41/36	46/40
Dimensions (HxWxD)	mm	305x775x600	305x775x600	305x775x600	305x990x600	305x990x600	305x1,175x600	305x1,665x600	305x1,665x600	
Machine weight	kg	26.0	26.0	26.0	31.0	32.0	35.0	47.0	48.0	
Piping connections	Liquid (Flare)	mm	φ 6.4	φ 6.4	φ 6.4	φ 6.4	φ 6.4	φ 9.5	φ 9.5	
	Gas (Flare)		φ 12.7	φ 12.7	φ 12.7	φ 12.7	φ 12.7	φ 15.9	φ 15.9	
	Drain		VP25 (External Dia, 32/Internal Dia, 25)							
Panel (Option)	Model	BYBC32G-W1		BYBC50G-W1		BYBC63G-W1		BYBC125G-W1		
	Colour	White (10Y9/0.5)								
	Dimensions (HxWxD)	mm	53x1,030x680	53x1,030x680	53x1,030x680	53x1,245x680	53x1,245x680	53x1,430x680	53x1,920x680	
	Weight	kg	8.0	8.0	8.0	8.5	8.5	9.5	12.0	12.0

### Ceiling Mounted Cassette Corner Type



MODEL		FXKQ25MAVE	FXKQ32MAVE	FXKQ40MAVE	FXKQ63MAVE	
Power supply		1-phase, 220-240 V/220 V, 50/60 Hz				
Cooling capacity	kcal/h (*1)	2,500	3,200	4,000	6,300	
	Btu/h (*1)	9,900	12,600	16,000	24,900	
	kW	(*1)	2.9	3.7	4.7	7.3
(*2)		2.8	3.6	4.5	7.1	
Power consumption	kW	0.066	0.066	0.076	0.105	
Casing		Galvanised steel plate				
Airflow rate (H/L)	m <sup>3</sup> /min	11/9	11/9	13/10	18/15	
	cfm	388/318	388/318	459/353	635/530	
Sound level (H/L)	220 V	dB(A)	38/33	38/33	40/34	42/37
	240 V		40/35	40/35	42/36	44/39
Dimensions (HxWxD)	mm	215x1,110x710	215x1,110x710	215x1,110x710	215x1,310x710	
Machine weight	kg	31.0	31.0	31.0	34.0	
Piping connections	Liquid (Flare)	mm	φ 6.4	φ 6.4	φ 6.4	φ 9.5
	Gas (Flare)		φ 12.7	φ 12.7	φ 12.7	φ 15.9
	Drain		VP25 (External Dia, 32/Internal Dia, 25)			
Panel (Option)	Model	BYK45FJW1		BYK71FJW1		
	Colour	White (10Y9/0.5)				
	Dimensions (HxWxD)	mm	70x1,240x800	70x1,240x800	70x1,240x800	70x1,440x800
	Weight	kg	8.5	8.5	8.5	9.5

Note: Specifications are based on the following conditions:

- Cooling: (\*1) Indoor temp. of 27°CDB, 19.5°CWB, and outdoor temp. of 35°CDB. (\*2) Indoor temp. of 27°CDB, 19°CWB, and outdoor temp. of 35°CDB.
- Equivalent piping length: 7.5 m •Level difference: 0 m
- Capacity of indoor unit is only for reference. Actual capacity of indoor unit is based on the total capacity index. (See Engineering Data Book for details.)
- Sound level: (FXCQ-M) Anechoic chamber conversion value, measured at a point 1.5 m downward from the unit centre.  
(FXKQ-MA) Anechoic chamber conversion value, measured at a point 1 m in front of the unit and 1 m downward.  
During actual operation, these values are normally somewhat higher as a result of ambient conditions.

## Slim Ceiling Mounted Duct Type (700 mm width type)

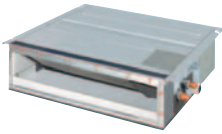

MODEL	with drain pump	FXDQ20PBVE	FXDQ25PBVE	FXDQ32PBVE	
	without drain pump	FXDQ20PBVET	FXDQ25PBVET	FXDQ32PBVET	
Power supply		1-phase, 220-240 V/220 V, 50/60 Hz			
Cooling capacity	kcal/h (*1)	2,000	2,500	3,200	
	Btu/h (*1)	7,800	9,900	12,600	
	kW	(*1)	2.3	2.9	3.7
		(*2)	2.2	2.8	3.6
Power consumption (FXDQ-PBVE)	kW	0.086	0.086	0.089	
Power consumption (FXDQ-PBVET)	kW	0.067	0.067	0.070	
Casing		Galvanised steel plate			
Airflow rate (HH/H/L)	m <sup>3</sup> /min	8.0/7.2/6.4	8.0/7.2/6.4	8.0/7.2/6.4	
	cfm	282/254/226	282/254/226	282/254/226	
External static pressure	Pa	30-10*1			
Sound level (HH/H/L)*2*3	dB(A)	33/31/29	33/31/29	33/31/29	
Dimensions (HxWxD)	mm	200x700x620	200x700x620	200x700x620	
Machine weight	kg	23.0	23.0	23.0	
Piping connections	Liquid (Flare)	φ 6.4	φ 6.4	φ 6.4	
	Gas (Flare)	φ 12.7	φ 12.7	φ 12.7	
	Drain	VP20 (External Dia, 26/Internal Dia, 20)			

## Slim Ceiling Mounted Duct Type (900/1,100 mm width type)

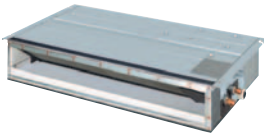

MODEL	with drain pump	FXDQ40NBVE	FXDQ50NBVE	FXDQ63NBVE	
	without drain pump	FXDQ40NBVET	FXDQ50NBVET	FXDQ63NBVET	
Power supply		1-phase, 220-240 V/220 V, 50/60 Hz			
Cooling capacity	kcal/h (*1)	4,000	5,000	6,300	
	Btu/h (*1)	16,000	19,800	24,900	
	kW	(*1)	4.7	5.8	7.3
		(*2)	4.5	5.6	7.1
Power consumption (FXDQ-NBVE)	kW	0.160	0.165	0.181	
Power consumption (FXDQ-NBVET)	kW	0.147	0.152	0.168	
Casing		Galvanised steel plate			
Airflow rate (HH/H/L)	m <sup>3</sup> /min	10.5/9.5/8.5	12.5/11.0/10.0	16.5/14.5/13.0	
	cfm	371/335/300	441/388/353	583/512/459	
External static pressure	Pa	44-15*1			
Sound level (HH/H/L)*2*3	dB(A)	34/32/30	35/33/31	36/34/32	
Dimensions (HxWxD)	mm	200x900x620	200x900x620	200x1,100x620	
Machine weight	kg	27.0	28.0	31.0	
Piping connections	Liquid (Flare)	φ 6.4	φ 6.4	φ 9.5	
	Gas (Flare)	φ 12.7	φ 12.7	φ 15.9	
	Drain	VP20 (External Dia, 26/Internal Dia, 20)			

Note: Specifications are based on the following conditions:

- Cooling: (\*1) Indoor temp. of 27°CDB, 19.5°CWB, and outdoor temp. of 35°CDB. (\*2) Indoor temp. of 27°CDB, 19°CWB, and outdoor temp. of 35°CDB.
  - \*1: External static pressure is changeable to set by the remote controller. This pressure means "High static pressure - Standard". (Factory setting is 10 Pa for FXDQ-PB models and 15 Pa for FXDQ-NB models.)
  - \*2: The values of operation sound level represent those for rear-suction operation. Sound level values for bottom-suction operation can be obtained by adding 5 dB(A).
  - \*3: Values are based on the following conditions: external static pressure of 10 Pa.
  - Equivalent piping length: 7.5 m •Level difference: 0 m
  - Capacity of indoor unit is only for reference. Actual capacity of indoor unit is based on the total capacity index. (See Engineering Data Book for details.)
  - Sound level: Anechoic chamber conversion value, measured at a point 1.5 m downward from the unit centre.
- During actual operation, these values are normally somewhat higher as a result of ambient conditions.

### Ceiling Mounted Duct Type



MODEL		FXMQ20PVE	FXMQ25PVE	FXMQ32PVE	FXMQ40PVE	FXMQ50PVE	
Power supply		1-phase, 220-240 V/220 V, 50/60 Hz					
Cooling capacity	kcal/h (*1)	2,000	2,500	3,200	4,000	5,000	
	Btu/h (*1)	7,800	9,900	12,600	16,000	19,800	
	kW	(*1)	2.3	2.9	3.7	4.7	5.8
		(*2)	2.2	2.8	3.6	4.5	5.6
Power consumption	kW	0.081	0.081	0.085	0.194	0.215	
Casing		Galvanised steel plate					
Airflow rate (HH/H/L)	m <sup>3</sup> /min	9/7.5/6.5	9/7.5/6.5	9.5/8/7	16/13/11	18/16.5/15	
	cfm	318/265/230	318/265/230	335/282/247	565/459/388	635/582/530	
External static pressure	Pa	30-100 * <sup>1</sup>	30-100 * <sup>1</sup>	30-100 * <sup>1</sup>	30-160 * <sup>1</sup>	50-200 * <sup>1</sup>	
Sound level (HH/H/L)	dB(A)	33/31/29	33/31/29	34/32/30	39/37/35	41/39/37	
Dimensions (HxWxD)	mm	300x550x700	300x550x700	300x550x700	300x700x700	300x1,000x700	
Machine weight	kg	25.0	25.0	25.0	28.0	36.0	
Piping connections	Liquid (Flare)	φ 6.4					
	Gas (Flare)	φ 12.7					
	Drain	VP25 (External Dia, 32/Internal Dia, 25)					

MODEL		FXMQ63PVE	FXMQ80PVE	FXMQ100PVE	FXMQ125PVE	FXMQ140PVE	
Power supply		1-phase, 220-240 V/220 V, 50/60 Hz					
Cooling capacity	kcal/h (*1)	6,300	8,000	10,000	12,500	14,300	
	Btu/h (*1)	24,900	31,700	39,600	49,500	57,000	
	kW	(*1)	7.3	9.3	11.6	14.5	16.7
		(*2)	7.1	9.0	11.2	14.0	16.0
Power consumption	kW	0.230	0.298/	0.376	0.461	0.461	
Casing		Galvanised steel plate					
Airflow rate (HH/H/L)	m <sup>3</sup> /min	19.5/17.5/16	25/22.5/20	32/27/23	39/33/28	46/39/32	
	cfm	688/618/565	883/794/706	1,130/953/812	1,377/1,165/988	1,624/1,377/1,130	
External static pressure	Pa	50-200 * <sup>1</sup>	50-200 * <sup>1</sup>	50-200 * <sup>1</sup>	50-200 * <sup>1</sup>	50-140 * <sup>1</sup>	
Sound level (HH/H/L)	dB(A)	42/40/38	43/41/39	43/41/39	44/42/40	46/45/43	
Dimensions (HxWxD)	mm	300x1,000x700	300x1,000x700	300x1,400x700	300x1,400x700	300x1,400x700	
Machine weight	kg	36.0	36.0	46.0	46.0	47.0	
Piping connections	Liquid (Flare)	φ 9.5					
	Gas (Flare)	φ 15.9					
	Drain	VP25 (External Dia, 32/Internal Dia, 25)					

Note: Specifications are based on the following conditions;

- Cooling: (\*1) Indoor temp. of 27°CDB, 19.5°CWB, and outdoor temp. of 35°CDB.
- (\*2) Indoor temp. of 27°CDB, 19°CWB, and outdoor temp. of 35°CDB.

★ 1: External static pressure can be modified using a remote controller that offers seven (FXMQ20-32P), thirteen (FXMQ40P), fourteen (FXMQ50-125P) or ten (FXMQ140P) levels of control. These values indicate the lowest and highest possible static pressures. The standard static pressure is 50 Pa for FXMQ20-32P and 100 Pa for FXMQ40-140P.

• Equivalent piping length: 7.5 m

• Level difference: 0 m

• Capacity of indoor unit is only for reference. Actual capacity of indoor unit is based on the total capacity index. (See Engineering Data Book for details.)

• Sound level: Anechoic chamber conversion value, measured at a point 1.5 m downward from the unit centre.

During actual operation, these values are normally somewhat higher as a result of ambient conditions.

## Ceiling Mounted Duct Type



MODEL		FXMQ200MAVE	FXMQ250MAVE	
Power supply		1-phase, 220-240 V/220 V, 50/60 Hz		
Cooling capacity	kcal/h (*1)	19,800	24,800	
	Btu/h (*1)	78,500	98,300	
	kW	(*1)	23.0	28.8
		(*2)	22.4	28.0
Power consumption	kW	1.294	1.465	
Casing		Galvanised steel plate		
Airflow rate (H/L)	m <sup>3</sup> /min	58/50	72/62	
	cfm	2,047/1,765	2,542/2,189	
External static pressure	Pa	132-221 *1	191-270 *1	
Sound level (H/L)	220 V	dB(A)	48/45	
	240 V			49/46
Dimensions (HxWxD)	mm	470x1,380x1,100	470x1,380x1,100	
Machine weight	kg	137.0	137.0	
Piping connections	Liquid (Flare)	φ 9.5	φ 9.5	
	Gas (Brazing)	φ 19.1	φ 22.2	
	Drain	PS1B		

## Ceiling Suspended Type



MODEL		FXHQ32MAVE	FXHQ63MAVE	FXHQ100MAVE	
Power supply		1-phase, 220-240 V/220 V, 50/60 Hz			
Cooling capacity	kcal/h (*1)	3,200	6,300	10,000	
	Btu/h (*1)	12,600	24,900	39,600	
	kW	(*1)	3.7	7.3	11.6
		(*2)	3.6	7.1	11.2
Power consumption	kW	0.111	0.115	0.135	
Casing		White (10Y9/0.5)			
Airflow rate (H/L)	m <sup>3</sup> /min	12/10	17.5/14	25/19.5	
	cfm	424/353	618/494	883/688	
Sound level (H/L)	dB(A)	36/31	39/34	45/37	
Dimensions (HxWxD)	mm	195x960x680	195x1,160x680	195x1,400x680	
Machine weight	kg	24.0	28.0	33.0	
Piping connections	Liquid (Flare)	φ 6.4	φ 9.5	φ 9.5	
	Gas (Flare)	φ 12.7	φ 15.9	φ 15.9	
	Drain	VP20 (External Dia, 26/Internal Dia, 20)			

Note: Specifications are based on the following conditions;

- Cooling: (\*1) Indoor temp. of 27°CDB, 19.5°CWB, and outdoor temp. of 35°CDB.
- (\*2) Indoor temp. of 27°CDB, 19°CWB, and outdoor temp. of 35°CDB.

★ 1: External static pressure is changeable to change over the connectors inside electrical box, this pressure means "Standard-High static pressure".

• Equivalent piping length: 7.5 m

• Level difference: 0 m

• Capacity of indoor unit is only for reference. Actual capacity of indoor unit is based on the total capacity index. (See Engineering Data Book for details.)

• Sound level: (FXMQ-MA) Anechoic chamber conversion value, measured at a point 1.5 m downward from the unit centre.

(FXHQ-MA) Anechoic chamber conversion value, measured at a point 1 m in front of the unit and 1 m downward. During actual operation, these values are normally somewhat higher as a result of ambient conditions.

### Wall Mounted Type



MODEL		FXAQ20MAVE	FXAQ25MAVE	FXAQ32MAVE	FXAQ40MAVE	FXAQ50MAVE	FXAQ63MAVE	
Power supply		1-phase, 220-240 V/220 V, 50/60 Hz						
Cooling capacity	kcal/h(*1)	2,000	2,500	3,200	4,000	5,000	6,300	
	Btu/h(*1)	7,800	9,900	12,600	16,000	19,800	24,900	
	kW	(*1)	2.3	2.9	3.7	4.7	5.8	7.3
		(*2)	2.2	2.8	3.6	4.5	5.6	7.1
Power consumption	kW	0.016	0.022	0.027	0.020	0.027	0.050	
Casing		White (3.0Y8.5/0.5)						
Airflow rate (H/L)	m <sup>3</sup> /min	7.5/4.5	8/5	9/5.5	12/9	15/12	19/14	
	cfm	265/159	282/177	318/194	424/318	530/424	671/494	
Sound level (H/L)	dB(A)	35/29	36/29	37/29	39/34	42/36	46/39	
Dimensions (HxWxD)	mm	290x795x230	290x795x230	290x795x230	290x1,050x230	290x1,050x230	290x1,050x230	
Machine weight	kg	11.0	11.0	11.0	14.0	14.0	14.0	
Piping connections	Liquid (Flare)	mm	φ 6.4	φ 6.4	φ 6.4	φ 6.4	φ 6.4	φ 9.5
	Gas (Flare)		φ 12.7	φ 12.7	φ 12.7	φ 12.7	φ 12.7	φ 15.9
	Drain		VP13 (External Dia, 18/Internal Dia, 13)					

### Floor Standing Type/Concealed Floor Standing Type



FXLQ



FXNQ

MODEL		FXLQ20MAVE	FXLQ25MAVE	FXLQ32MAVE	FXLQ40MAVE	FXLQ50MAVE	FXLQ63MAVE	
		FXNQ20MAVE	FXNQ25MAVE	FXNQ32MAVE	FXNQ40MAVE	FXNQ50MAVE	FXNQ63MAVE	
Power supply		1-phase, 220-240 V/220 V, 50/60 Hz						
Cooling capacity	kcal/h(*1)	2,000	2,500	3,200	4,000	5,000	6,300	
	Btu/h(*1)	7,800	9,900	12,600	16,000	19,800	24,900	
	kW	(*1)	2.3	2.9	3.7	4.7	5.8	7.3
		(*2)	2.2	2.8	3.6	4.5	5.6	7.1
Power consumption	kW	0.049	0.049	0.090	0.090	0.110	0.110	
Casing		FXLQ: Ivory white (5Y7.5/1)/FXNQ: Galvanised steel plate						
Airflow rate (H/L)	m <sup>3</sup> /min	7/6	7/6	8/6	11/8.5	14/11	16/12	
	cfm	247/212	247/212	282/212	388/300	494/388	565/424	
Sound level (H/L)	220 V	dB(A)	35/32	35/32	35/32	38/33	39/34	40/35
	240 V		37/34	37/34	37/34	40/35	41/36	42/37
Dimensions (HxWxD)	FXLQ	mm	600x1,000x222	600x1,000x222	600x1,140x222	600x1,140x222	600x1,420x222	600x1,420x222
	FXNQ		610x930x220	610x930x220	610x1,070x220	610x1,070x220	610x1,350x220	610x1,350x220
Machine weight	FXLQ	kg	25.0	25.0	30.0	30.0	36.0	36.0
	FXNQ		19.0	19.0	23.0	23.0	27.0	27.0
Piping connections	Liquid (Flare)	mm	φ 6.4	φ 6.4	φ 6.4	φ 6.4	φ 6.4	φ 9.5
	Gas (Flare)		φ 12.7	φ 12.7	φ 12.7	φ 12.7	φ 12.7	φ 15.9
	Drain		21O.D.					

Note: Specifications are based on the following conditions;

•Cooling: (\*1) Indoor temp. of 27°CDB, 19.5°CWB, and outdoor temp. of 35°CDB.

(\*2) Indoor temp. of 27°CDB, 19°CWB, and outdoor temp. of 35°CDB.

•Equivalent piping length: 7.5 m

•Level difference: 0 m

•Capacity of indoor unit is only for reference. Actual capacity of indoor unit is based on the total capacity index. (See Engineering Data Book for details.)

•Sound level: (FXAQ-MA) Anechoic chamber conversion value, measured at a point 1 m in front of the unit and 1 m downward.

(FXLQ-MA, FXNQ-MA) Anechoic chamber conversion value, measured at a point 1.5 m in front of the unit at a height of 1.5 m.

During actual operation, these values are normally somewhat higher as a result of ambient conditions.

## Connection unit series indoor units

- \* A type of BEV unit is necessary for each Connection unit series indoor unit. Refer to the Engineering Data for details.
- \* Group control between Connection Unit series equipment within one system is possible. However, group control with the other VRV indoor units is not possible.

### Ceiling Suspended Cassette Type



MODEL	Indoor unit		FXUQ71MAV1	FXUQ100MAV1	FXUQ125MAV1	
	Connection unit		BEVQ71MAVE	BEVQ100MAVE	BEVQ125MAVE	
Power supply			1-phase, 220-240 V, 50 Hz			
Cooling capacity		Kcal/h(*1)	7,100	10,000	12,500	
		Btu/h(*1)	28,300	39,600	49,500	
		kW	(*1)	8.3	11.6	14.5
			(*2)	8.0	11.2	14.0
Power consumption		kW	0.189	0.298	0.298	
Casing		White (10Y9/0.5)				
Indoor unit	Airflow rate (H/L)		m <sup>3</sup> /min	19/14	29/21	32/23
			cfm	671/494	1,024/741	1,130/812
	Sound level (H/L)	230 V	dB(A)	40/35	43/38	44/39
	Dimensions (HxWxD)		mm	165x895x895	230x895x895	230x895x895
	Machine weight		kg	25	31	31
Piping connections		Liquid	φ 9.5 (Flare)			
		Gas	φ 15.9 (Flare)			
		Drain	VP 20 (External Dia. 26/Internal Dia. 20)			

Note: Specifications are based on the following conditions;

- Cooling: (\*1) Indoor temp. of 27°CDB, 19.5°CWB, and outdoor temp. of 35°CDB.  
(\*2) Indoor temp. of 27°CDB, 19°CWB, and outdoor temp. of 35°CDB.
- Equivalent piping length: 7.5 m
- Level difference: 0 m
- Capacity of indoor unit is only for reference. Actual capacity of indoor unit is based on the total capacity index. (See Engineering Data Book for details.)
- Sound level: Anechoic chamber conversion value, measured at a point 1.5 m below the unit centre.  
During actual operation, these values are normally somewhat higher as a result of ambient conditions.

### Residential indoor units with connection to BP units

Residential indoor units can be connected to the VRVIII single outdoor unit series by BP units.

#### Ceiling Mounted Cassette Type



MODEL		FCQ35BVE	FCQ50BVE	FCQ60BVE	FCQ71BVE
Power supply		1-phase, 220-240 V/220 V, 50/60 Hz			
Airflow rates (H)	m <sup>3</sup> /min (cfm)	14.0 (494)	15.0 (530)	19.0 (671)	
Sound levels (H/L)*	dB (A)	33/29		35/30	
Fan speed		2 steps			
Temperature control		Microcomputer control			
Dimensions (HxWxD)	mm	230x840x840			
Machine weight	kg	24			
Piping connections	Liquid (Flare)	ø6.4			ø9.5
	Gas (Flare)	ø9.5	ø12.7		ø15.9
	Drain	I.D ø25xO.D ø32			
Heat insulation		Both liquid and gas pipes			
Panel (Option)	Model	BYC125K-W1			
	Colour	White			
	Dimensions(HxWxD)	mm	40x950x950		
	Weight	kg	5		

Note: \* For 220 V operation.

#### Ceiling Mounted Cassette (Compact Multi Flow) Type

600 x 600

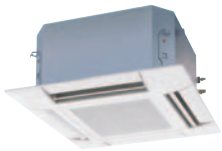

MODEL		FFQ25BV1B	FFQ35BV1B	FFQ50BV1B	FFQ60BV1B
Power supply		1-phase, 220-240 V, 50 Hz			
Airflow rates (H)	m <sup>3</sup> /min (cfm)	9.0 (318)	10.0 (353)	12.0 (424)	15.0 (530)
Sound levels (H/L)*	dB (A)	29.5/24.5	32/25	36/27	41/32
Fan speed		2 steps			
Temperature control		Microcomputer control			
Dimensions (HxWxD)	mm	286x575x575			
Machine weight	kg	17.5			
Piping connections	Liquid (Flare)	ø6.4			
	Gas (Flare)	ø9.5	ø12.7		
	Drain	VP20 (External Dia. 26/Internal Dia. 20)			
Heat insulation		Both liquid and gas pipes			
Panel (Option)	Model	BYFQ60B8W1			
	Colour	White			
	Dimensions(HxWxD)	mm	55x700x700		
	Weight	kg	2.7		

Note: \* Anechoic chamber conversion value, measured according to JIS parameters and criteria. During operation these values are somewhat higher owing to ambient conditions.



## Ceiling Mounted Built-in Type

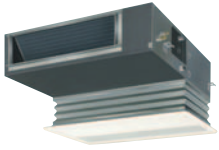

MODEL		FBQ60BV1	FBQ71BV1
Power supply		1-phase, 220-240 V, 50 Hz	
Airflow rates (H)	m <sup>3</sup> /min (cfm)	17.0 (600)	19.0 (670)
Sound levels (H/L)*	dB (A)	41/35	
Fan speed		2 steps	
Temperature control		Microcomputer control	
Dimensions (HxWxD)	mm	300x1,000x800	
Machine weight	kg	41	
Piping connections	Liquid (Flare)	ø6.4	ø9.5
	Gas (Flare)	ø12.7	ø15.9
	Drain	I.D ø25xO.D ø32	
Heat insulation		Both liquid and gas pipes	
Panel (Option)	Model	BYBS71DJW1	
	Colour	White	
	Dimensions (HxWxD)	55x1,100x500	
	Weight	4.5	

Note: \* For 220 V operation.

## Slim Ceiling Mounted Duct Type

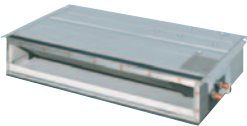
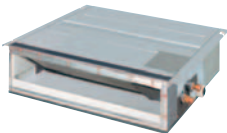

MODEL		FDKS25EAVMB	FDKS35EAVMB	FDKS25CAVMB	FDKS35CAVMB	FDKS50CVMB	FDKS60CVMB
Power supply		1-phase, 220-240 V/220 V, 50/60 Hz					
Airflow rates (H)	m <sup>3</sup> /min (cfm)	8.7 (307)	9.5 (335)	10.0 (353)	12.0 (424)	16.0 (565)	
Sound levels (H/L/SL)*	dB (A)	35/31/29			37/33/31	38/34/32	
Fan speed		5 steps, quiet and automatic					
Temperature control		Microcomputer control					
Dimensions (HxWxD)	mm	200x700x620	200x900x620			200x1,100x620	
Machine weight	kg	21	25	27	30		
Piping connections	Liquid (Flare)	ø6.4					
	Gas (Flare)	ø9.5			ø12.7	ø15.9	
	Drain	VP20 (External Dia. 26/Internal Dia. 20)					
Heat insulation		Both liquid and gas pipes					
External static pressure	Pa	30	40				

Note: \* The operation sound level values represent those for rear-suction operation and an external static pressure of 30 Pa for FDKS-EA and 40 Pa for FDKS-C. Sound level values for bottom-suction operation can be obtained by adding 6 dB (A) for FDKS-EA and 5 dB (A) for FDKS-C.

## Wall Mounted Type





MODEL		FTKS25DVM	FTKS35DVM	FTKS50FVM	FTKS60FVM	FTKS71FVM
Power supply		1-phase, 220-240 V/220 V, 50/60 Hz				
Front panel colour		White				
Airflow rates (H)	m <sup>3</sup> /min (cfm)	8.7 (307)	8.9 (314)	14.7 (519)	16.2 (572)	17.4 (614)
Sound levels (H/L/SL)	dB (A)	37/25/22	39/26/23	43/34/31	45/36/33	46/37/34
Fan speed		5 steps, quiet and automatic				
Temperature control		Microcomputer control				
Dimensions (HxWxD)	mm	283x800x195		290x1,050x238		
Machine weight	kg	9		12		
Piping connections	Liquid (Flare)	ø6.4				
	Gas (Flare)	ø9.5		ø12.7		ø15.9
	Drain	ø18.0				
Heat insulation		Both liquid and gas pipes				



### BP units for connection to residential indoor units

- A BP unit is an innovative development which allows VRVIII single outdoor unit series to be connected to residential indoor units.
- A BP unit has the ability to precisely vary refrigerant volume to meet the cooling requirements of individual room spaces.
- A BP unit is easy to disassemble, making repairing and recycling simple.

					
MODEL				BPMKS967B3B	BPMKS967B2B
Power supply				1-phase, 220 - 240 V/220 V, 50/60 Hz	
Number of ports				3 (connectable to 1-3 indoor units)	2 (connectable to 1-2 indoor units)
Power consumption	W	10			
Running current	A	0.05			
Dimensions (HxWxD)	mm	180x294 (+356*)x350			
Machine weight	kg	8	7.5		
Number of wiring connections				3 for power supply (including earth wiring), 2 for interunit wiring (outdoor unit-BP, BP-BP), 4 for interunit wiring (BP-indoor unit)	
Piping connections (Brazing)	Liquid	Main	mm	ø9.5x1	
		Branch	mm	ø6.4x3	ø6.4x2
	Gas	Main	mm	ø19.1x1	
		Branch	mm	ø15.9x3	ø15.9x2
Heat insulation				Both liquid and gas pipes	
Connectable indoor units				2.5 kW class to 7.1 kW class residential indoor units	
Min. rated capacity of connectable indoor units	kW	2.5			
Max. rated capacity of connectable indoor units	kW	20.8	14.2		

Note: \* Total auxiliary piping length.

### VRV III single outdoor unit series



MODEL			RSXQ8PY1	RSXQ10PY1	RSXQ12PY1	RSXQ14PY1	RSXQ16PY1	RSXQ18PY1
Power supply			3-phase 4-wire system, 380–415 V, 50 Hz					
Cooling capacity (*1)(*2)	kcal/h (*1)		19,400	24,300	29,000	34,600	39,000	42,400
	Btu/h (*1)		76,800	96,200	115,000	137,000	155,000	168,000
	kW	(*1)		22.5	28.2	33.7	40.2	45.3
(*2)			22.4	28.0	33.5	40.0	45.0	49.0
Power consumption (*2)	kW		5.24	7.90	8.93	12.4	14.2	16.4
Capacity control	%		20-100	14-100	14-100	10-100	10-100	9-100
Casing colour			Ivory white (5Y7.5/1)					
Compressor	Type		Hermetically sealed scroll type					
	Motor output	kW	3.6x1	(1.4+4.5)x1	(1.8+4.5)x1	(1.4+4.5+4.5)x1	(2.7+4.5+4.5)x1	(2.8+4.5+4.5)x1
Airflow rate	m <sup>3</sup> /min		180	185	233	233	233	239
Dimensions (HxWxD)	mm		1,680x930x765			1,680x1,240x765		
Machine weight	kg		188	232	268	312	312	324
Sound level	dB(A)		57	58	60	60	60	63
Operation range	°CDB		–5 to 43					
Refrigerant	Type		R-410A					
	Charge	kg	4.7	4.9	6.0	6.3	6.5	6.7
Piping connections	Liquid	mm	φ9.5 (Brazing)	φ9.5 (Brazing)	φ12.7 (Brazing)	φ12.7 (Brazing)	φ12.7 (Brazing)	φ15.9 (Brazing)
	Gas	mm	φ19.1 (Brazing)	φ22.2 (Brazing)	φ28.6 (Brazing)	φ28.6 (Brazing)	φ28.6 (Brazing)	φ28.6 (Brazing)

Note: Specifications are based on the following conditions;

- Cooling: (\*1) Indoor temp. of 27°CDB, 19.5°CWB, and outdoor temp. of 35°CDB.  
(\*2) Indoor temp. of 27°CDB, 19°CWB, and outdoor temp. of 35°CDB.
- Equivalent piping length: 7.5 m
- Level difference: 0 m

- Sound level: Anechoic chamber conversion value, measured at a point 1 m in front of the unit at a height of 1.5 m.  
During actual operation, these values are normally somewhat higher as a result of ambient conditions.

### Outdoor unit combinations

Model name	kW	HP	Capacity index	Total capacity index of connectable indoor units*			Maximum number of connectable indoor units
				Combination (%)*			
				50%	100%	130%	
RSXQ8PY1	22.4	8 HP	200	100	200	260	13
RSXQ10PY1	28.0	10 HP	250	125	250	325	16
RSXQ12PY1	33.5	12 HP	300	150	300	390	19
RSXQ14PY1	40.0	14 HP	350	175	350	455	22
RSXQ16PY1	45.0	16 HP	400	200	400	520	26
RSXQ18PY1	49.0	18 HP	450	225	450	585	29

\* Total capacity index of connectable indoor units must be 50%–130% of the capacity index of the outdoor unit.

$$\text{Combination ratio} = \frac{\text{Total capacity index of the indoor units}}{\text{Capacity index of the outdoor unit}}$$

### Ceiling Mounted Cassette (Round Flow) Type

No.	Item	Type	FXFQ25P	FXFQ32P	FXFQ40P	FXFQ50P	FXFQ63P	FXFQ80P	FXFQ100P	FXFQ125P
1	Decoration panel		BYCP125K-W1							
2	Sealing member of air discharge outlet		KDBH55K160F							
3	Panel spacer		KDBP55H160FA							
4	Filter related	High efficiency filter unit 65%	KAFP556B80							
		High efficiency filter unit 90%	KAFP557B80							
		Replacement high efficiency filter 65%	KAFP552B80							
		Replacement high efficiency filter 90%	KAFP553B80							
		Filter chamber	KDDFP55B160							
		Long life replacement filter Non-woven type	KAFP551K160							
		Ultra long-life filter	KAFP55B160							
5	Fresh air intake kit	Chamber type	KDDP55B160							
		Without T shape and fan	KDDP55B160K							
		With T shape without fan	KDDP55X160							
6	Branch duct chamber	KDJP55B80								
7	Chamber connection kit	KKSJ55KA160								
8	Insulation kit for high humidity	KDTP55K80								

### Ceiling Mounted Cassette (Compact Multi Flow) Type

No.	Item	Type	FXZQ20M	FXZQ25M	FXZQ32M	FXZQ40M	FXZQ50M
1	Decoration panel		BYFQ60B8W1				
2	Sealing member of air discharge outlet		KDBH44BA60				
3	Panel spacer		KDBQ44BA60A				
4	Replacement long-life filter		KAFQ441BA60				
5	Fresh air intake kit	Direct installation type	KDDQ44XA60				

### Ceiling Mounted Cassette (Double Flow) Type

No.	Item	Type	FXCQ20M FXCQ25M FXCQ32M	FXCQ40M	FXCQ50M	FXCQ63M	FXCQ80M	FXCQ125M
1	Decoration panel		BYBC32G-W1	BYBC50G-W1	BYBC63G-W1	BYBC125G-W1		
2	Filter related	High efficiency filter 65% *1	KAFJ532G36	KAFJ532G56	KAFJ532G80	KAFJ532G160		
		High efficiency filter 90% *1	KAFJ533G36	KAFJ533G56	KAFJ533G80	KAFJ533G160		
		Filter chamber bottom suction	KDDFJ53G36	KDDFJ53G56	KDDFJ53G80	KDDFJ53G160		
		Long life replacement filter	KAFJ531G36	KAFJ531G56	KAFJ531G80	KAFJ531G160		

Note: \*1 Filter chamber is required if installing high efficiency filter.

### Ceiling Mounted Cassette Corner Type

No.	Item	Type	FXKQ25MA	FXKQ32MA	FXKQ40MA	FXKQ63MA
1	Panel related	Decoration panel	BYK45FJW1			
		Panel spacer	KPBKJ52F56W			
2	Air inlet and air discharge outlet related	Long life replacement filter	KAFJ521F56			
		Air discharge grille	K-HV7AW			
		Air discharge blind panel	KDBJ52F56W			
		Flexible duct (with shutter)	KFDJ52FA56			

### Slim Ceiling Mounted Duct Type (700 mm width type)

No.	Item	Type	FXDQ20PB	FXDQ25PB	FXDQ32PB
1	Insulation kit for high humidity		KDT25N32		

### Slim Ceiling Mounted Duct Type (900/1,100 mm width type)

No.	Item	Type	FXDQ40NB	FXDQ50NB	FXDQ63NB
1	Insulation kit for high humidity		KDT25N50		

### Ceiling Mounted Duct Type

No.	Item	Type	FXMQ20P FXMQ25P FXMQ32P	FXMQ40P	FXMQ50P FXMQ63P FXMQ80P	FXMQ100P FXMQ125P FXMQ140P	FXMQ200MA FXMQ250MA
1	Drain pump kit		-				KDU30L250VE
2	High efficiency filter	65%	KAF372AA36	KAF372AA56	KAF372AA80	KAF372AA160	KAFJ372L280
		90%	KAF373AA36	KAF373AA56	KAF373AA80	KAF373AA160	KAFJ373L280
3	Filter chamber		KDDF37AA36	KDDF37AA56	KDDF37AA80	KDDF37AA160	KDJ3705L280
4	Long life replacement filter		KAF371AA36	KAF371AA56	KAF371AA80	KAF371AA160	KAFJ371L280
5	Long life filter chamber kit		KAF375AA36	KAF375AA56	KAF375AA80	KAF375AA160	-
6	Service panel	White	KTBJ25K36W	KTBJ25K56W	KTBJ25K80W	KTBJ25K160W	
		Fresh white	KTBJ25K36F	KTBJ25K56F	KTBJ25K80F	KTBJ25K160F	
		Brown	KTBJ25K36T	KTBJ25K56T	KTBJ25K80T	KTBJ25K160T	
7	Air discharge adaptor		KDAJ25K36A	KDAJ25K56A	KDAJ25K71A	KDAJ25K140A	

### Ceiling Suspended Type

No.	Item	Type	FXHQ32MA	FXHQ63MA	FXHQ100MA
1	Drain pump kit		KDU50N60VE	KDU50N125VE	
2	Replacement long-life filter (Resin net)		KAF501DA56	KAF501DA80	KAF501DA112
3	L-type piping kit (for upward direction)		KHFP5MA63	KHFP5MA160	

### Wall Mounted Type

No.	Item	Type	FXAQ20MA	FXAQ25MA	FXAQ32MA	FXAQ40MA	FXAQ50MA	FXAQ63MA
1	Drain pump kit		K-KDU572EVE					

### Floor Standing Type

No.	Item	Type	FXLQ20MA	FXLQ25MA	FXLQ32MA	FXLQ40MA	FXLQ50MA	FXLQ63MA
1	Long life replacement filter		KAFJ361K28		KAFJ361K45		KAFJ361K71	

### Concealed Floor Standing Type

No.	Item	Type	FXNQ20MA	FXNQ25MA	FXNQ32MA	FXNQ40MA	FXNQ50MA	FXNQ63MA
1	Long life replacement filter		KAFJ361K28		KAFJ361K45		KAFJ361K71	

### Ceiling Suspended Cassette Type

No.	Item	Type	FXUQ71MA	FXUQ100MA	FXUQ125MA
1	Replacement long-life filter		KAF495FA140		
2	Sealing member of air discharge outlet (*1)		KDBH49FA80	KDBH49FA140	
3	Decoration panel for air discharge		KDBT49FA80	KDBT49FA140	
4	Vertical flap kit		KDGJ49FA80	KDGJ49FA140	
5	L-shape piping kit		KHFP49MA140		

**Note:** (\*1): This option is necessary for setting up 2-way (opposing directional) airflow when the air conditioner is installed.

### Ceiling Mounted Cassette Type

No.	Item	Type	FCQ35BVE	FCQ50BVE	FCQ60BVE	FCQ71BVE
1	Decoration panel				BYC125K-W1	
2	Panel spacer				KDBP55H160WA	
3	Fresh air intake kit	Chamber type	Without T-shaped pipe and fan*1		KDDP55D160	
			With T-shaped pipe, without fan*2		KDDP55D160K	
		Direct installation type*3			KDDJ55X160	
4	High-efficiency filter		(Colourimetric method 65%)		KAFP556D80	
			(Colourimetric method 90%)		KAFP557D80	
5	Replacement high-efficiency filter		(Colourimetric method 65%)		KAFP552H80	
			(Colourimetric method 90%)		KAFP553H80	
6	High-efficiency filter chamber				KDDF55DA160	
7	Replacement long-life filter				KAF551KA160	
8	Branch duct chamber				KDJ55K80	

Notes: \*1. With a suction chamber. Fresh air intake is from 2 holes on the sides of the connection chamber. (This method should be selected if a wireless remote controller is used.)  
 \*2. Without a suction chamber. Fresh air intake is from 2 holes on the connection chamber via a T-shaped pipe connection. (A wireless remote controller cannot be used in this case.)  
 \*3. Without a suction chamber. Fresh air intake is directly from a hole on the main unit.

### Ceiling Mounted Cassette (Compact Multi Flow) Type

No.	Item	Type	FFQ25BV1B	FFQ35BV1B	FFQ50BV1B	FFQ60BV1B
1	Decoration panel				BYFQ60B8W1	
2	Replacement long-life filter				KAFQ441BA60	
3	Fresh air intake kit	Direct installation type			KDDQ44XA60	
4	Sealing member for air discharge outlet				KDBH44BA60	
5	Panel spacer				KDBQ44BA60A	

### Ceiling Mounted Built-in Type

No.	Item	Type	FBQ60BV1	FBQ71BV1
1	Decoration panel			BYBS71DJW1
2	Service access panel			KTBJ25L80W
3	High-efficiency filter		(Colourimetric method 65%)	KAF252LA80
			(Colourimetric method 90%)	KAF253LA80
4	Replacement long-life filter	Resin net		KAFJ251K80
5	Filter chamber for bottom suction			KAJ25LA80D
6	Filter chamber for rear suction			KAJ25LA80B
7	Canvas duct			KSAJ25K80
8	Discharge grille		ø150	K-DG5DW
			ø200	K-DG9DW
9	Discharge chamber		ø150	K-DGC5D
			ø200	K-DGC9D
10	Branch duct	ø150 → ø200		K-DDV20A
11	Flexible duct		ø150	K-FDS151C(1m)/K-FDS152C(2m)/K-FDS153C(3m)/K-FDS154C(4m)/K-FDS155C(5m)/K-FDS156C(6m)
			ø200	K-FDS201C(1m)/K-FDS202C(2m)/K-FDS203C(3m)/K-FDS204C(4m)/K-FDS205C(5m)/K-FDS206C(6m)
12	Blind board			KBBJ25KA80
13	Adaptor for discharge			KDAJ25K71
14	Flange for suction			KDJ2507K80

### Slim Ceiling Mounted Duct Type

No.	Item	Type	FDKS25EAVMB	FDKS35EAVMB	FDKS25CAVMB	FDKS35CAVMB	FDKS50CVMB	FDKS60CVMB
1	Suction grille							KDGF19A45
2	Insulation kit for high humidity			KDT25N32			KDT25N50	KDT25N63



## Wall Mounted Type

No.	Item	Type	FTKS25DVM	FTKS35DVM	FTKS50FVM	FTKS60FVM	FTKS71FVM
1	Titanium apatite photocatalytic air-purifying filter		KAF970A46		KAF952B42		

Note: Filter is a standard accessory. It should be replaced approximately 3 years.

## BP Units

for connection to residential indoor units

No.	Item	Type	BPMKS967B2B	BPMKS967B3B
1	REFNET joint		KHRP26A22T	

Note: A single BP unit does not require a REFNET joint. 2 BP units require only 1 REFNET joint, and 3 BP units require only 2 REFNET joints.

## Outdoor Units

Item		Type	RSXQ8PY1	RSXQ10PY1	RSXQ12PY1	RSXQ14PY1	RSXQ16PY1	RSXQ18PY1
		Distributive piping	REFNET header	KHRP26M22H (Max. 4 branch) KHRP26M33H (Max. 8 branch)			KHRP26M22H (Max. 4 branch) KHRP26M33H (Max. 8 branch) KHRP26M72H (Max. 8 branch)	
REFNET joint	KHRP26A22T KHRP26A33T			KHRP26A22T KHRP26A33T KHRP26A72T				
Auxiliary pipe set*1			KHFP22B8P	KHFP22B10P	KHFP22B12P	KHFP22B16P		KHFP22B18P
Central drain pan kit			KWC26C280			KWC26C450		
Digital pressure gauge kit			BHGP26A1					

Note: \*1. Auxiliary pipe sets are not attached to the outdoor units. If necessary, use the optional accessories.

## Individual Control Systems for VRV Indoor Units

### Navigation remote controller (Wired remote controller) (Option)



BRC1E61

- Large buttons and arrow keys for easy operation.
- Guide on display gives an explanation of each setting.
- Backlight and dot matrix LCD display for easy viewing.
- Weekly schedule timer can be set up easily.
- 10 display languages are available.  
(English, German, French, Spanish, Italian, Portuguese, Greek, Dutch, Russian and Turkish)

### Wired remote controller (Option)

Displays current airflow, swing, temperature, operating mode and timer settings.



BRC1C62

### Wired remote controller with weekly schedule timer (Option)

Adds weekly schedule timer function.



BRC1D61

- Notes: 1. Standard remote controllers (BRC1C62) not required.  
2. If the BRC1D61 is connected to the centralised remote controllers (DCS303A51, DCS302CA61, DCS301BA61, DST301BA61), the schedule function is not available.

### The wired remote controller supports a wide range of control functions

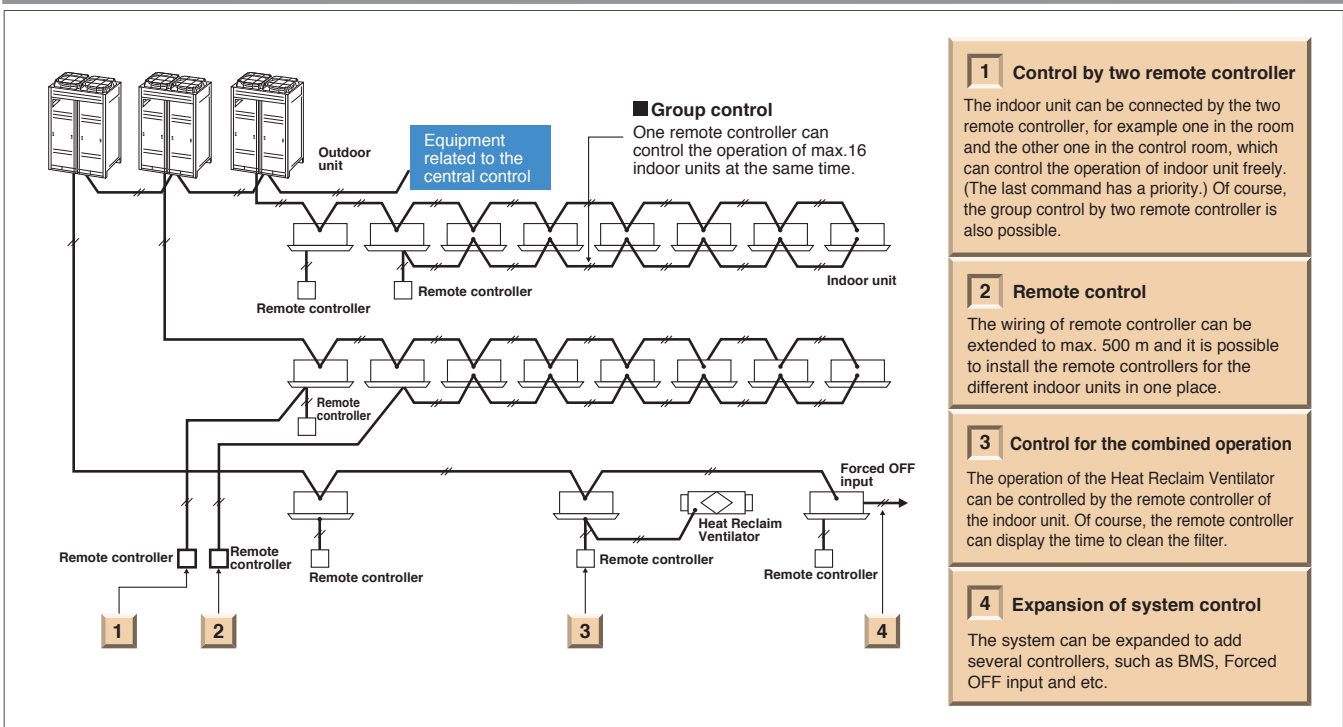



## Wireless remote controller (Option)



Wireless remote controller



Signal receiver unit (Separate type)

- The same operation modes and settings as with wired remote controllers are possible.
- A compact signal receiver unit (separate type) to be mounted into a wall or ceiling is included.
  - A signal receiver unit (installed type) for a Ceiling Mounted Cassette (Round Flow, Compact Multi Flow, Double Flow) type, Ceiling Suspended type and Wall Mounted type is mounted into the indoor unit.



Signal receiver unit can be installed on the panel  
ex. Ceiling Mounted Cassette (Round Flow) type

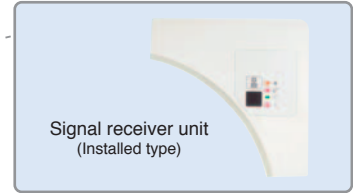

Signal receiver unit (Installed type)

\*Wireless remote controller and signal receiver unit are sold as a set.  
\*Refer to page 43 for the name of each model.

## Simplified remote controller (Option)



Exposed type (BRC2C51)



Concealed type (For hotel use) (BRC3A61)

- The remote controller has centralised its frequently used operation selectors and switches (on/off, operation mode, temperature setting and airflow volume), making itself suitable for use in hotel rooms or conference rooms.
- The exposed type remote controller is fitted with a thermostat sensor.



The concealed type remote controller smartly fits into a night table or console panel in a hotel room.

## Wide variation of remote controllers for VRV indoor units

	FXFQ	FXZQ	FXCQ	FXKQ	FXDQ	FXMQ	FXHQ	FXAQ	FXL(N)Q	FXUQ
<b>Navigation remote controller</b> (Wired remote controller) (BRC1E61)	●	●	●	●	●	●	●	●	●	●
<b>Wired remote controller</b> (BRC1C62)	●	●	●	●	●	●	●	●	●	●
<b>Wired remote controller with weekly schedule timer</b> (BRC1D61)	●	●	●	●	●	●	●	●	●	●
<b>Wireless remote controller*</b> (Installed type signal receiver unit)	●	●	●				●	●		●
<b>Wireless remote controller*</b> (Separate type signal receiver unit)				●	●	●			●	
<b>Simplified remote controller</b> (Exposed type) (BRC2C51)					●	●			●	
<b>Simplified remote controller</b> (Concealed type: for Hotel use) (BRC3A61)					●	●			●	

\*Refer to page 43 for the name of each model.

## Advanced Control Systems for VRV Indoor Units

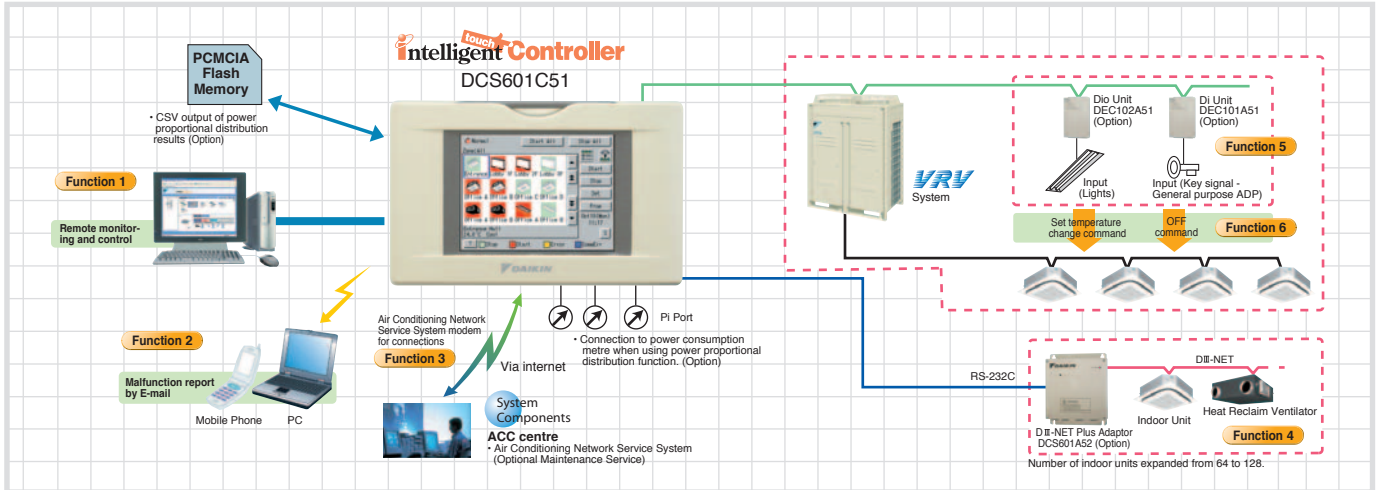

## Centralised Control Systems for VRV Indoor Units

- Up to 64 groups of indoor units (128 units) can be centrally controlled.
- Optional controllers for centralised control can be combined freely, and system can be designed in accordance with building scale and purpose.
- System integration with various air-conditioning peripheral equipment, such as a Heat Reclaim Ventilator, is easy.
- Wiring can be run up to a total length of 2 km, and adapts easily to large-scale system expansion.

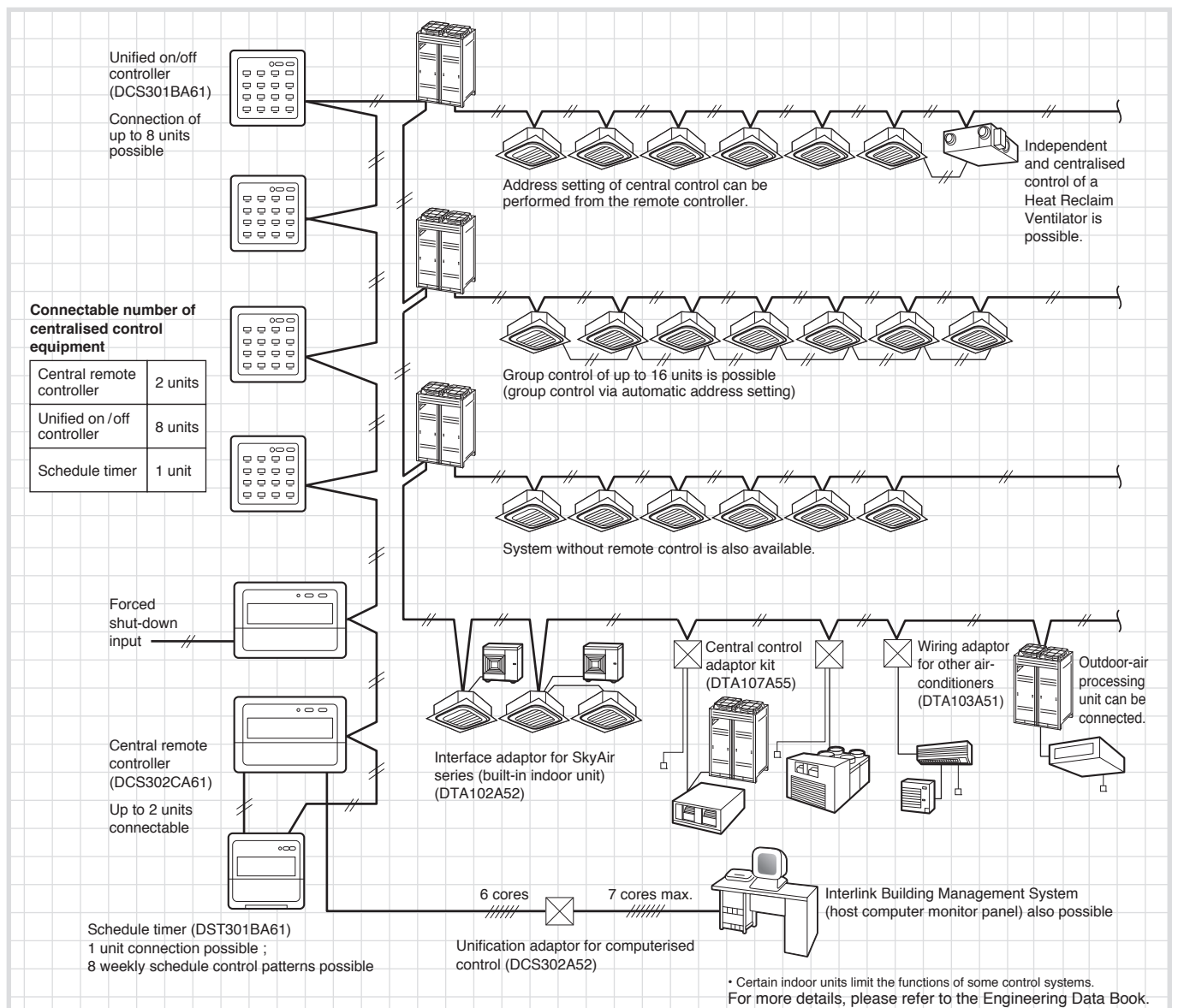

## Communication functions in the user-friendly icon-based multilingual controller simplify centralised control of the VRV system.

- Colour LCD touch panel icon display
- Small manageable size
- Simplified engineering
- Multi language (English, French, Italian, German, Spanish, Dutch, Portuguese, Chinese and Korean)
- Yearly schedule
- PPD (Power Proportional Distribution function) (Option)
- Auto heat/cool change-over
- Temperature limitation
- Enhanced history function
- Air Conditioning Network Service System (Optional Maintenance Service)
- Simple Interlock Function

- Function 1** Support for centralised control from elsewhere using a PC with a Web browser (Option)
- Function 2** Sending of e-mail alerts to a specified address when malfunctions occur (Option)
- Function 3** Built-in modem for connecting to Air Conditioning Network Service System (Option)
- Function 4** Doubling of number of connectable indoor units by adding a DIII-NET Plus Adaptor (Option)
- Function 5** Management of facilities/equipment other than A/C units (By adding Dio unit or Di unit)
- Function 6** Simple Interlock Function



DCS303A51

### Residential central remote controller\* (Option)

#### Max. 16 groups of indoor units can be easily controlled with the large LCD panel.

- Max. 16 groups (128 indoor units) controllable
- Backlight and large LCD panel for easy readability
- ON/OFF, temperature settings and scheduling can be controlled individually for indoor units.
- All indoor units can be turned on or off at once with "ALL" button.
- Each group has a dedicated button for convenience.
- Outside temperature display

\* For residential use only. Cannot be used with other centralised control equipment.



DCS302CA61

### Central remote controller (Option)

#### Max. 64 groups (zones) of indoor units can be controlled individually same as LCD Remote controller.

- Max. 64 groups (128 indoor units) controllable
- Max. 128 groups (128 indoor units) are controllable by using 2 central remote controllers, which can control from 2 different places.
- Zone control
- Malfunction code display
- Max. wiring length 1,000 m (Total: 2,000 m)
- Connectable with Unified ON/OFF controller, schedule timer and BMS system
- Airflow volume and direction can be controlled individually for indoor units in each group operation.
- Ventilation volume and mode can be controlled for the Heat Reclaim Ventilator.
- Up to 4 ON/OFF pairs can be set per day by connecting a schedule timer.



DCS301BA61

### Unified ON/OFF controller (Option)

#### Max. 16 groups of indoor units can be operated simultaneously/individually.

- Max. 16 groups (128 indoor units) controllable
- 2 remote controllers can be used to control from 2 different places.
- Operating status indication (Normal operation, Alarm)
- Centralised control indication
- Max. wiring length 1,000 m (Total: 2,000 m)
- Compact size casing (Thickness: 16 mm)
- Connectable with Central Remote controller, Schedule timer and BMS system



DST301BA61

### Schedule timer (Option)

#### Max. 128 indoor units can be operated as programmed schedule.

- Max. 128 indoor units controllable
- When used in combination with a central remote controller, a maximum of 8 weekly schedule patterns can be set, while the central controller can be used to select desired zones. Up to 2 ON/OFF pairs can be set per day.
- Max. 48 hours back up power supply
- Max. wiring length 1,000 m (Total: 2,000 m)
- Compact size casing (Thickness: 16 mm)
- Connectable with Central Remote controller, Unified ON/OFF controller and BMS system

### Operation Control System Optional Accessories

For VRV indoor unit use

No.	Item	Type	FXFQ-P	FXZQ-M	FXCQ-M	FXKQ-MA	FXDQ-PB FXDQ-NB	FXMQ-P	FXMQ-MA	FXHQ-MA	FXAQ-MA	FXLQ-MA FXNQ-MA	FXUQ-MA
1	Remote controller	Wireless type	BRC7F635F	BRC7E531W	BRC7C67	BRC4C63	BRC4C66	BRC4C66	BRC4C64	BRC7EA66	BRC7EA619	BRC4C64	BRC7CA529W
		Wired type	BRC1C62										
2	Navigation remote controller (Wired remote controller)		BRC1E61										
3	Wired remote controller with weekly schedule timer		BRC1D61										
4	Simplified remote controller (Exposed type)		BRC2C51										
5	Remote controller for hotel use (Concealed type)		BRC3A61										
6	Adaptor for wiring		*KRP1C63	*KRP1BA57	*KRP1B61	KRP1B61	*KRP1B56	*KRP1C64	KRP1B61	KRP1BA54	—	KRP1B61	—
7-1	Wiring adaptor for electrical appendices (1)		*KRP2A62	*KRP2A62	*KRP2A61	KRP2A61	*KRP2A53	*KRP2A61	KRP2A61	*KRP2A62	*KRP2A61	KRP2A61	*KRP2A62
7-2	Wiring adaptor for electrical appendices (2)		*KRP4AA53	*KRP4AA53	*KRP4AA51	KRP4AA51	*KRP4A54	*KRP4AA51	KRP4AA51	*KRP4AA52	*KRP4AA51	KRP4AA51	*KRP4AA53
8	Remote sensor (for indoor temperature)		KRCS01-4B	KRCS01-1B				KRCS01-4B	KRCS01-1B				
9	Installation box for adaptor PCB☆		Notes 2, 3 KRP1H98	Notes 4, 6 KRP1BA101	Notes 2, 3 KRP1B96	—	Notes 4, 6 KRP1BA101	Notes 2, 3 KRP4A96	—	Note 3 KRP1CA93	Notes 2, 3 KRP4AA93	—	KRP1BA97
10	External control adaptor for outdoor unit		*DTA104A62	*DTA104A62	*DTA104A61	DTA104A61	*DTA104A53	*DTA104A61	DTA104A61	*DTA104A62	*DTA104A61	DTA104A61	—
11	Adaptor for multi tenant		*DTA114A61	—				*DTA114A61	—		*DTA114A61	—	

- Notes: 1. Installation box ☆ is necessary for each adaptor marked ★.  
 2. Up to 2 adaptors can be fixed for each installation box.  
 3. Only one installation box can be installed for each indoor unit.  
 4. Up to 2 installation boxes can be installed for each indoor unit.  
 5. Installation box ☆ is necessary for second adaptor.  
 6. Installation box ☆ is necessary for each adaptor.

For Residential indoor unit use

No.	Item	Type	FCQ-B	FFQ-B	FBQ-B	FDKS-EA FDKS-C(A)	FTKS-D FTKS-F	
1	Remote controller	Wired type <sup>Note 1</sup>	BRC1C61					—
		Wireless type	BRC7C613W	BRC7E531W	—	— <sup>Note 2</sup>		
2	Adaptor for wiring		Note 3 KRP1BA57	Note 4 KRP1BA57	KRP1BA54	—		
3	Wiring adaptor for electrical appendices		Note 3 KRP4AA53	Note 4 KRP4AA53	KRP4AA51	—		
4	Installation box for adaptor PCB		KRP1B98	KRP1BA101	—			
5	Remote sensor (for indoor temperature)		—	KRCS01-1B	—			
6	Wiring adaptor for time clock/remote controller <sup>Note 5</sup> (Normal open pulse contact/normal open contact)		—				KRP413AB1S	
7	Remote controller loss prevention chain		—				KKF917A4	

- Notes: 1. Wiring for wired remote controller should be obtained locally.  
 2. A wireless remote controller is a standard accessory for FDKS and FTKS models.  
 3. Installation box for adaptor PCB (KRP1B98) is necessary.  
 4. Installation box for adaptor PCB (KRP1BA101) is necessary.  
 5. Time clock and other devices should be obtained locally.

## System Configuration

No.	Item		Model No.	Function
1	Residential central remote controller		Note 3 DCS303A51	•Up to 16 groups of indoor units (128 units) can be easily controlled using the large LCD panel. ON/OFF, temperature settings and scheduling can be controlled individually for indoor units.
2	Central remote controller		Note 2 DCS302CA61	•Up to 64 groups of indoor units(128 units) can be connected, and ON/OFF, temperature setting and monitoring can be accomplished individually or simultaneously. Connectable up to 2 controllers in one system.
2-1	Electrical box with earth terminal (3 blocks)		KJB311AA	
3	Unified ON/OFF controller		Note 2 DCS301BA61	•Up to 16 groups of indoor units(128 units) can be turned, ON/OFF individually or simultaneously, and operation and malfunction can be displayed. Can be used in combination with up to 8 controllers.
3-1	Electrical box with earth terminal (2 blocks)		KJB212AA	
3-2	Noise filter (for electromagnetic interface use only)		KEK26-1A	
4	Schedule timer		Note 2 DST301BA61	•Programmed time weekly schedule can be controlled by unified control for up to 64 groups of indoor units (128 units). Can turn units ON/OFF twice per day.
5	5-room centralised controller for residential indoor units	For FTKS-D/F, FDKS-EA/C(A)	Note 4 KRC72	•Up to 5 indoor units can be controlled. This is a low cost system which can only control ON/OFF.  •Adaptors required to connect products other than those of the VRV System to the high-speed DIII-NET communication system adopted for the VRV System.  * To use any of the above optional controllers, an appropriate adaptor must be installed on the product unit to be controlled.
6	Interface adaptor for residential indoor units	For FTKS-D/F, FDKS-EA/C(A)	KRP928BB2S	
		For FCQ-B, FFQ-B, FBQ-B	DTA112BA51	
7	Interface adaptor for SkyAir-series	For SkyAir, FD(Y)M-FA, FDY-KA, FDYB-KA, FVY(P),J-A, FXUQ-MA	* DTA102A52	
8	Central control adaptor kit	For UAT(Y)-K(A),FD-K	* DTA107A55	
9	Wiring adaptor for other air-conditioner		* DTA103A51	
10	DIII-NET Expander Adaptor		DTA109A51	•Up to 1024 units can be centrally controlled in 64 different groups. •Wiring restrictions (max. length: 1,000 m, total wiring length: 2,000 m, max. number of branches: 16) apply to each adaptor.
10-1	Mounting plate		KRP4A92	•Fixing plate for DTA109A51

- Notes: 1. Installation box for ★adaptor must be obtained locally.  
 2. For FXUQ-MAV1, an interface adaptor (DTA102A52) for the SkyAir series is necessary. For residential indoor units, an interface adaptor (KRP928BB2S or DTA112BA51) is required for each indoor unit.  
 3. For residential use only. Cannot be used with other centralised control equipment.  
 4. A wiring adaptor (KRP413AB1S) is also required for each indoor unit.

## Building Management System

No.	Item				Model No.	Function	
1	intelligent Touch Controller	Basic	Hardware	intelligent Touch Controller	DCS601C51	•Air-Conditioning management system that can be controlled by a compact all-in-one unit.	
1-1		Option	Hardware	DIII-NET plus adaptor	DCS601A52	•Additional 64 groups (10 outdoor units) is possible.	
1-2			Software	PPD	DCS002C51	•PPD: Power Proportional Distribution function	
1-3			Web	DCS004A51	•Monitors and controls the air conditioning system using the Internet and a Web browser application on a PC.		
1-4	Electrical box with earth terminal (4 blocks)				KJB411A	•Wall embedded switch box.	
2	intelligent Manager III	Basic	Hardware	Number of units to be connected	128 units	DAM602B52	•Air conditioner management system that can be controlled by personal computers.
					256 units	DAM602B51	
					512 units	DAM602B51x2	
					768 units	DAM602B51x3	
					1024 units	DAM602B51x4	
2-1	Option	Software	PPD	DAM002A51	•Power Proportional Distribution function		
2-2			Web	DAM004A51	•Monitors and controls the air conditioning system using the Internet and a Web browser application on a PC.		
2-3			ECONO	DAM003A51	•ECONO (Energy saving functions.)		
2-4	Optional DIII Ai unit				DAM101A51	•External temperature sensor for intelligent Manager III.	
2-5	Di unit				DEC101A51	•8 pairs based on a pair of On/Off input and abnormality input.	
2-6	Dio unit				DEC102A51	•4 pairs based on a pair of On/Off input and abnormality input.	
3	Communication line	*1 Interface for use in BACnet*			DMS502B51	•Interface unit to allow communications between VRV and BMS. Operation and monitoring of air-conditioning systems through BACnet* communication.	
3-1		Optional DIII board			DAM411B51	•Expansion kit, installed on DMS502B51, to provide 2 more DIII-NET communication ports. Not usable independently.	
3-2		Optional Di board			DAM412B51	•Expansion kit, installed on DMS502B51, to provide 16 more wattmeter pulse input points. Not usable independently.	
4		*2 Interface for use in LonWorks*			DMS504B51	•Interface unit to allow communications between VRV and BMS. Operation and monitoring of air-conditioning systems through LonWorks* communication.	
5	Contact/analogue signal	Parallel interface Basic unit			DPF201A51	•Enables ON/OFF command, operation and display of malfunction; can be used in combination with up to 4 units.	
6		Temperature measurement units			DPF201A52	•Enables temperature measurement output for 4 groups; 0-5VDC.	
7		Temperature setting units			DPF201A53	•Enables temperature setting input for 16 groups; 0-5VDC.	
8		Unification adaptor for computerised control			* DCS302A52	•Interface between the central monitoring board and central control units.	

- Notes: \*1. BACnet\* is a registered trademark of American Society of Heating, Refrigerating and Air-Conditioning Engineers (ASHRAE).  
 \*2. LonWorks\* is a trademark of Echelon Corporation registered in the United States and other countries.  
 \*3. Installation box for ★ adaptor must be obtained locally.





Warning



- Daikin products are manufactured for export to numerous countries throughout the world. Prior to purchase, please confirm with your local authorised importer, distributor and/or retailer whether this product conforms to the applicable standards, and is suitable for use, in the region where the product will be used. This statement does not purport to exclude, restrict or modify the application of any local legislation.
- Ask a qualified installer or contractor to install this product. Do not try to install the product yourself. Improper installation can result in water or refrigerant leakage, electrical shock, fire or explosion.
- Use only those parts and accessories supplied or specified by Daikin. Ask a qualified installer or contractor to install those parts and accessories. Use of unauthorised parts and accessories or improper installation of parts and accessories can result in water or refrigerant leakage, electrical shock, fire or explosion.
- Read the User's Manual carefully before using this product. The User's Manual provides important safety instructions and warnings. Be sure to follow these instructions and warnings.

If you have any enquiries, please contact your local importer, distributor and/or retailer.

### Cautions on product corrosion

1. Air conditioners should not be installed in areas where corrosive gases, such as acid gas or alkaline gas, are produced.
2. If the outdoor unit is to be installed close to the sea shore, direct exposure to the sea breeze should be avoided. If you need to install the outdoor unit close to the sea shore, contact your local distributor.



JMI-0107

Organization:  
DAIKIN INDUSTRIES, LTD.  
AIR CONDITIONING MANUFACTURING DIVISION

Scope of Registration:  
THE DESIGN/DEVELOPMENT AND MANUFACTURE OF  
COMMERCIAL AIR CONDITIONING, HEATING, COOLING,  
REFRIGERATING EQUIPMENT, HEATING EQUIPMENT,  
RESIDENTIAL AIR CONDITIONING EQUIPMENT, HEAT  
RECLAIM VENTILATION, AIR CLEANING EQUIPMENT,  
COMPRESSORS AND VALVES.



JQA-1452

Organization:  
DAIKIN INDUSTRIES  
(THAILAND) LTD.

Scope of Registration:  
THE DESIGN/DEVELOPMENT  
AND MANUFACTURE OF AIR  
CONDITIONERS AND THE  
COMPONENTS INCLUDING  
COMPRESSORS USED FOR THEM



EC99J2044

All of the Daikin Group's business facilities and subsidiaries in Japan are certified under the ISO 14001 international standard for environment management.

Đại lý phân phối



### DAIKIN INDUSTRIES, LTD.

- HEAD OFFICE  
Umeda Center Bldg., 2-4-12, Nakazaki-Nishi, Kita-ku, Osaka, 530-8323 Japan
  - CÔNG TY CỔ PHẦN VIỆT KIM  
Tầng 14-15, tòa nhà Nam Á, 201-203 Cách Mạng Tháng 8, P.4, Q.3, TP.HCM  
Tel: (08) 62 504 888 Fax: (08) 62 504 999
  - VĂN PHÒNG CHÍNH
  - CHI NHÁNH HÀ NỘI  
Tầng 12, tòa nhà Ocean Park Tower, 1 Đào Duy Anh, Quận Đống Đa, Hà Nội  
Tel: (04) 35 657 677 Fax: (04) 35 657 688
  - CHI NHÁNH ĐÀ NẴNG  
Tầng 12, Lô A2.1, Đường 30/4, P. Hòa Cường Bắc, Q. Hải Châu, TP. Đà Nẵng  
Tel: (0511) 362 4250 Fax: (0511) 362 4251
- [www.daikin.com.vn](http://www.daikin.com.vn)