



Sixnet[®] Series

VT-MODEM
Industrial Modems

Hardware Guide | December 2018

LP1089-A

©2018 Red Lion Controls, Inc. All rights reserved. Red Lion, the Red Lion logo and Sixnet are registered trademarks of Red Lion Controls, Inc. All other company and product names are trademarks of their respective owners.

Red Lion Controls, Inc.
20 Willow Springs Circle
York, PA 17406 USA

CONTACT INFORMATION:

Inside US: +1 (877) 432-9908
Outside US: +1 (717) 767-6511

Website: www.redlion.net
Email: support@redlion.net



Table of Contents

Preface	iii
Disclaimer	iii
Purpose	iii
Audience	iii
Compliance Statements, Certifications & User Information	iii
FCC Compliance Statement	iii
User Compliance Information	iv
Canadian Compliance Statement	iv
Regulatory Information	v
Trademark Acknowledgments	v
Release Notes and Document Updates	v
Publication History	v
Related Documents	v
Document Comments	vi
Additional Product Information	vii
Safety Information	vii
Warnings/Cautions/Notes	vii
Hazardous Location and Installation Requirements	viii
AVERTISSEMENTS POUR INSTALLATION ET ENDROITS DANGEREUX	viii
Chapter 1 Product Overview and Highlights	1
Product Overview	1
Identifying the Modem You Have	2
VT-MODEM-2 Self-Dialing Feature	3
Dialing Upon Alarm From Any PLC	3
Sending A Message Based Upon A Switch Contact	3
VT-MODEM-3 RS485 Port	4
VT-MODEM SETUP WIZARD	4
Product Highlights	4
VT-MODEM 1-3	4
VT-MODEM-1 Features and Benefits	4
VT-MODEM-2 Features and Benefits	4
VT-MODEM-3 Features and Benefits	5
VT-MODEM Specifications	6
Chapter 2 Hardware Installation	8
Mounting the VT-MODEM	8



Electrical Connections	10
RS232 Connections	10
VT-MODEM-1 Power, Phone Line Connections	11
DC Power Wiring	11
Telephone Cable	11
VT-MODEM-2 Power, Phone Line, Self-Dial Connections	11
DC Power Wiring	11
Telephone Cable	12
PLC Self-Dial I/O Connections	12
VT-MODEM-3 Power, Phone Line, RS422 / RS485 Connections	12
DC Power Wiring	12
Telephone Cable	12
RS422 / RS485 Cabling and DIP Switch Settings	12
VT-MODEM-3 DIP Switch Summary	15
RS422 / RS485 Network Termination	15
Bias Resistors (RS485 Networks Only)	16
Configuring a PC Modem to Communicate with a VT-MODEM-3 in RS422 or RS485 Mode	17
Modem Configuration	18
Configuring a VT-MODEM	18
AT Command String At Power-up	18
Configuring a VT-MODEM as an External Modem on a PC	18
Modem Installation in Windows® 10	18
Modem Installation in Windows® 7	18
To Remove a Modem	19
Configuring a VT-MODEM Using VT-MODEM Setup Wizard	19
Setting the Modem's Baud Rate for the PLC	20
Limiting the Phone Line Connection Speed for Reliability	20
VT-MODEM Profile Summary	21
AT Command Summary	22
S Register Summary	26
Maintenance Information	28
Troubleshooting Tips	28
VT-MODEM Default LED Indications	28
Reconnecting Serial Cables	28
Resetting the VT-MODEM (all models)	28
Service and Support Information	29
Service Information	29
Product Support	29
Statement of Limited Warranty	30



Preface

Disclaimer

Portions of this document are intended solely as an outline of methodologies to be followed during the maintenance and operation of the VT-MODEM equipment/software. It is not intended as a step-by-step guide or a complete set of all procedures necessary and sufficient to complete all operations.

While every effort has been made to ensure that this document is complete and accurate at the time of release, the information that it contains is subject to change. Red Lion Controls is not responsible for any additions to or alterations of the original document. Industrial networks vary widely in their configurations, topologies, and traffic conditions. This document is intended as a general guide only. It has not been tested for all possible applications, and it may not be complete or accurate for some situations.

Users of this document are urged to heed warnings and cautions summarized at the front of the document, such as electrical hazard warnings.

Purpose

This manual gives specific information on how to install and connect the VT-MODEM to a PC.

Audience

The manual is intended for use by qualified personnel who are responsible for installing and maintaining network equipment in an industrial environment.

Compliance Statements, Certifications & User Information

FCC Compliance Statement

The Federal Communications Commission (FCC) has established rules which permit this device to be directly connected to the telephone network. Standardized jacks are used for these connections. This equipment should not be used on party lines or coin lines.

If this device is malfunctioning, it may also be causing harm to the telephone network; this device should be disconnected until the source of the problem can be determined and until repair has been made. If this is not done, the telephone company may temporarily disconnect service.

The telephone company may make changes in its technical operations and procedures; if such changes affect the compatibility or use of this device, the telephone company is required to give adequate notice of the changes.



If the telephone company requests information on what equipment is connected to their lines, inform them of:

- The telephone number that it is connected to,
- The Ringer Equivalence Number 0.3,
- The USOC jack required RJ11, and
- The FCC Registration Number 34579-MD-E

Items (b) and (d) are indicated on the label. The ringer equivalence number (REN) is used to determine how many devices can be connected to your telephone line. In most areas, the sum of the RENs of all devices on any one line should not exceed five (5.0). If too many devices are attached, they may not ring properly.

In the event of equipment malfunction, all repairs should be performed by our Company or authorized agent. It is the responsibility of users requiring service to report the need for service to our company or one of our authorized agents.

User Compliance Information

If this equipment causes interference to radio or television reception, which can be determined by turning the equipment off and on, the user is encouraged to try to correct the interference by one or more of the following measures:

In order to meet FCC emissions limits, this equipment must be used only with cables that comply with IEEE 802.3.

If necessary, the user should consult the dealer or an experienced radio/television technician for additional suggestions.

The user may find the following booklet prepared by the Federal Communications Commission helpful:

“How to Identify and Resolve Radio-TV Interference Problems”.

This booklet is available from: U.S. Government Printing Office, Washington DC, 20402 Stock No. 004-000-00345-4.

Canadian Compliance Statement

The VT-MODEM meets the procedural and specification requirements for certification under the Terminal Attachment Program.

Certification No.: 2991 8926 A

Issued To: Sixnet

Type Of Equipment: Multi-media Device

Trade Name And Model: VT-MODEM-1, VT-MODEM-2, VT-MODEM-3

Method Of Connection: CA11A

Ringer Equivalence No.: 0.3



Certified To: Specification Cs03 Issue 8

Network Interface: LS

Regulatory Information

FCC Part 15 and FCC Part 68; UL 508; CSA C22.2/142;

ACA TS 001- 1997; ACA TS 002-1997; AS/NZS3260-1993;

AS/NZS3548-1995; CTR21 (98/482/EC); EN55022; EIEC 950:1991;

Hazardous Locations: ANSI/ISA 12.12.01, CSA C22.2/213 (Class 1, Division 2 Groups A, B, C and D)

Trademark Acknowledgments

Red Lion Controls acknowledges and recognizes ownership of the following trademarked terms used in this document.

- Microsoft®, Windows® 10, Windows® 7, and Windows® are either registered trademark of the Microsoft Corporation in the United States and/or other countries.

All other company and product names are trademarks of their respective owners.

Release Notes and Document Updates

The hard copy and online versions of this document are revised only at major releases and, therefore, may not always contain the latest product information. As needed, Tech Notes and or Product Bulletins will be provided between major releases to describe any new information or document changes.

The latest online version of this document and all product updates can be accessed through the Red Lion web site at www.redlion.net/support/documentation

Publication History

The following information lists the release history of this document.

Issue/Revision	Release Date	Content Description
Revision A	December 2018	Document updated to new format and new firmware version added.
Initial Release	September 2013	Original version.

Related Documents

The following information lists available documents related to this product.



Issue/Revision	Release Date	Document Title
LP1087 Revision A	December 2018	VT-MODEM-4 Leased Line Industrial Modem Hardware Manual
LP1088 Revision A	December 2018	VT-MODEM-5 Advanced 56K Modem Hardware Manual

The following Technical Notes, in addition to others, are accessible at www.redlion.net. The VT-MODEM Wizard configurations (*.6ms), mentioned in these Technical notes, are provided at www.redlion.net.

TN 606	<p>VT-MODEM Replaces an Existing 1200, 2400, or 9600-Baud Modem</p> <p>This document describes the settings necessary to configure the VT-MODEM to functionally replace an existing 1200, 2400 or 9600-baud modem.</p>
TN 620	<p>Allen-Bradley SLC 5/03</p> <p>This technical note provides instructional tips for interfacing the Sixnet Industrial Telephone Modem with the Rockwell Software RSLinks 2.0 and RSLogics 500 and Allen-Bradley SLC500 Processors.</p>
TN 623	<p>Allen-Bradley MicroLogix 1000 and 1500 PLC</p> <p>The information in this document explains the procedure for interfacing a Sixnet Industrial Telephone Modem with an AB MicroLogix 1500 controller and a computer running the Rockwell RSLogix 500 programming software and the RSLINX communication software. This setup will allow a remote computer to go on-line with a MicroLogix via a telephone modem connection.</p>
TN 641	<p>GE Versamax Micro PLC</p> <p>This document explains the procedure of dialing and establishing a communications between a local PC running VersaPRO software and a remotely located GE Fanuc VersaMAX Micro Controller via a pair of Sixnet Industrial Modems.</p>
TN 642	<p>GE Fanuc 90-30 PLC</p> <p>This document explains the procedure of dialing and establishing a communications between a local PC running VersaPRO software and a remotely located GE Fanuc 90-30 Programmable Controller via a pair of Sixnet Industrial Modems.</p>
TN 640	<p>PLCdirect DL250 PLC</p> <p>This Technical Note defines the procedure for dialing and establishing communications between a PC running Directsoft32 software and a DL250 PLC via Sixnet Industrial modems.</p>
TN 647	<p>VT-MODEM Rev.3 changes some AT commands</p> <p>This technical note describes differences between the AT commands supported in current and previous revisions of the VT-MODEM-1, -2 and -3 and SiteTRAK -1T. This Technical Note is intended to aid existing customers in identifying and dealing with potential issues in converting to the newer revision products.</p>

Document Comments

Red Lion appreciates all comments that will help us to improve our documentation quality. The user can submit comments through the Red Lion Customer Service. Simply email us at customer.service@redlion.net.



Additional Product Information

Additional product information can be obtained by contacting the local sales representative or Red Lion through the contact numbers and/or e-mail addresses listed on the back of the cover.

Safety Information

	<p>WARNING – Must consult the guide in all cases where this symbol is marked. AVERTISSEMENT – Doivent consulter le guide dans tous les cas où ce symbole est marqué.</p>
---	--

Warnings/Cautions/Notes

Warnings apply to situations where personal injury or death may result.

Mises en garde s'appliquent aux situations où les risques de blessures graves ou mortelles peuvent en résulter

Cautions apply where damage to equipment may result.

Les mises en garde s'appliquent dans le cas où les dommages matériels peuvent en résulter

Notes apply where additional noteworthy information, not in the general text flow but applicable, is made available to the user.

Notes s'appliquent lorsque des informations dignes de mention, non pas dans l'enchaînement du texte mais il y a lieu, est mis à la disposition de l'utilisateur

General Safety Cautions and Warnings / Précautions et Avertissements de Sécurité Générale

	<p>CAUTION: If the equipment is used in the manner not specified by Red Lion, the protection provided by the equipment may be impaired. ATTENTION: Si l'équipement est utilisé d'une manière non spécifiée par Red Lion, la protection fournie par l'équipement peut être compromise.</p>
---	---

	<p>CAUTION: Do not operate the equipment in a manner not specified by this manual. ATTENTION: Ne pas faire fonctionner l'équipement d'une manière non spécifiée par ce manuel.</p>
---	--

	<p>WARNING: Install only in accordance with Local and National Codes of authorities having jurisdiction.</p> <p>AVERTISSEMENT: Installer uniquement, conformément aux codes locaux et nationaux des autorités ayant compétence.</p>
---	---

Hazardous Location and Installation Requirements

These products should not be used to replace proper safety interlocking. No software-based device (or any other solid-state device) should ever be designed to be responsible for the maintenance of consequential equipment or personnel safety. In particular, Red Lion disclaims any responsibility for damages, either direct or consequential, that result from the use of this equipment in any application.

All power, input and output (I/O) wiring must be in accordance with Class I, Division 2 wiring methods and in accordance with the authority having jurisdiction. Suitable for use in Class I, Division 2, Groups A, B, C and D hazardous locations, or non-hazardous locations only.

AVERTISSEMENTS POUR INSTALLATION ET ENDROITS DANGEREUX

Ces produits ne doivent pas être utilisés pour remplacer le verrouillage de sécurité approprié. Aucun dispositif basé sur un logiciel (ou tout autre dispositif à l'état solide) devraient jamais être conçus pour être responsable de l'entretien de l'équipement consécutifs ou la sécurité du personnel. En particulier, Red Lion décline toute responsabilité pour les dommages, directs ou indirects, résultant de l'utilisation de cet équipement dans n'importe quelle application.

Tout pouvoir, le câblage d'entrée et de sortie (I/O) doivent être conformes aux méthodes de câblage de Classe 1, Division 2 et conformément à l'autorité compétente. Cet équipement est adapté pour une utilisation en Classe1, Division 2, Groupes A, B, C et D ou endroits non-dangereux seulement.

	<p>WARNING: Explosion Hazard – Substitution of components may impair suitability for Class I, Division 2.</p> <p>AVERTISSEMENT - Risque d'explosion - La substitution de tout composant peut nuire à la conformité de Classe 1, Division 2.</p>
---	---

	<p>Warning – Do not remove or replace port connections while circuit is live unless the area is known to be free of ignitable concentrations of flammable substances. For the required marking for the port connections, instruction shall be included indicating that the marking shall be displayed on a prominent place on the end-enclosure.</p> <p>Avertissement – Ne pas retirer ou remplacer les connexions de port alors que le circuit est vivre à moins que la région est connue pour être libre d'ignitable les concentrations de substances inflammables. pour le marquage obligatoire pour les connexions de port, l'enseignement doit être inclus en indiquant que le marquage doit être affichée sur une place de premier plan dans l'enceinte.</p>
---	--



WARNING – Explosion Hazard – Do not disconnect equipment unless power has been switched off or the area is known to be non-hazardous.

AVERTISSEMENT - Risque d'explosion - Ne débranchez pas l'équipement à moins que l'alimentation ait été coupée ou que l'environnement est connu pour être non dangereux.



WARNING - Never install or work on electrical equipment or cabling during periods of lightning activity.

AVERTISSEMENT - Ne jamais installer ou travailler sur équipement électrique ou de câblage pendant les périodes d'activité de la foudre.



CAUTION: Do not perform any services on the unit unless qualified to do so. Do not substitute unauthorized parts or make unauthorized modifications to the unit.

ATTENTION: Ne pas effectuer de services sur l'appareil s'il n'est pas qualifié pour le faire. Ne pas substituer pièces non autorisées ou de modifications non autorisées de l'appareil.



WARNING: Properly ground the unit before connecting anything else to the unit. Units not properly grounded may result in a safety risk and could be hazardous and may void the warranty. See the grounding technique section of this manual for proper ways to ground the unit.

AVERTISSEMENT: L'unité doit être correctement mise à la terre avant tout raccordement à l'unité. Unités pas correctement mise à la terre peuvent causer un risque de sécurité et pourraient être dangereuses et peuvent annuler la garantie. Voir la section technique de mise à la terre dans ce mode d'emploi pour des moyens appropriés à la masse de l'appareil.

Chapter 1 Product Overview and Highlights

1.1 Product Overview

The Sixnet® VT-MODEMs are rugged industrial telephone modems that have been designed for operation in electrical enclosures installed in harsh environments. Each VT-MODEM supports all standard Hayes AT commands, Fax Class 1 and Class 2 commands and S-registers and therefore can be set-up as an external modem on any PC. The VT-MODEMs are compatible with any telecommunications or dial-up networking software.

A VT-MODEM allows easy access to PLCs, Sixnet I/O, and other devices via dial-in telephone connections. The modem may be DIN rail or panel mounted for convenient and easy installation adjacent to other DIN rail components inside of new or existing enclosures. Most Windows® software can communicate through a VT-MODEM to remote devices to perform file transfers, diagnostics, program debugging, and many other operations.

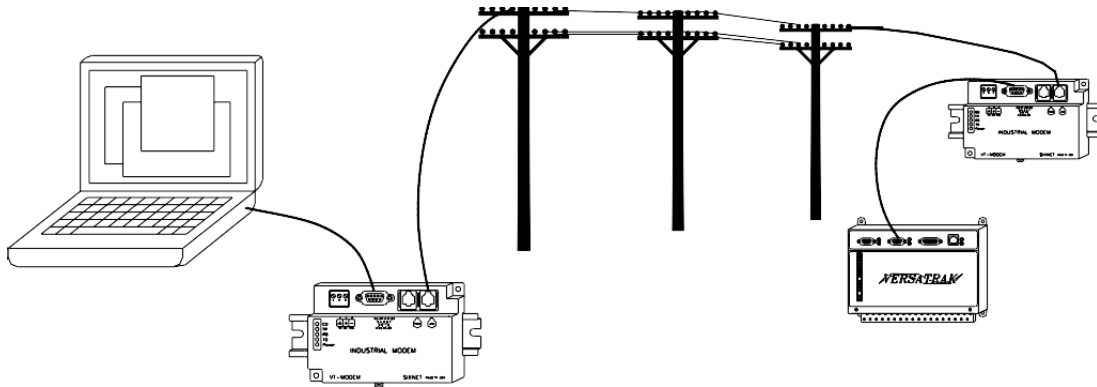

All Sixnet Industrial Modems allow communication to remote sites for data retrieval or diagnostics.

Note: All VT-MODEM models communicate over analog phone lines only.

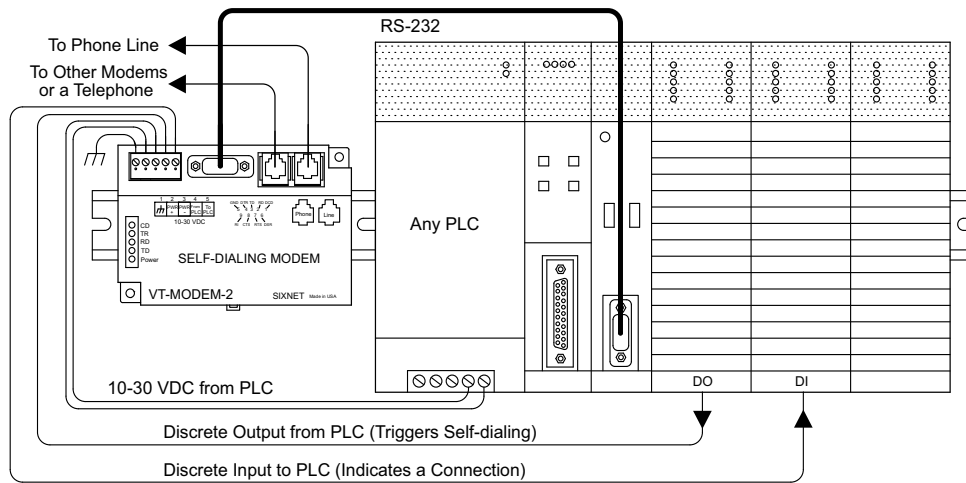

The Sixnet PLC Self-Dialing Modem (VT-MODEM-2) has all the features of the Sixnet Industrial Modem (VT-MODEM-1), plus the ability to dial out based on an alarm contact or PLC discrete output.

1.2 Identifying the Modem You Have

This section will show how to identify what revision of modem you have.

1. The Sixnet VT-MODEM Wizard will detect the version of the modem you have. Open the wizard and detect the modem you are connected to by selecting the COM port your modem is connected to and clicking the red Detect Modem button on most configuration screens. The firmware version of your modem is indicated as Rev 1, Rev 2 or Rev 3, otherwise the difference is seamless to the typical Wizard user.
2. On the back of the modem there is a white sticker called the back label that indicates among other things the revision number (Rev) and modem models. Please see the tables below to see how to interpret this number.

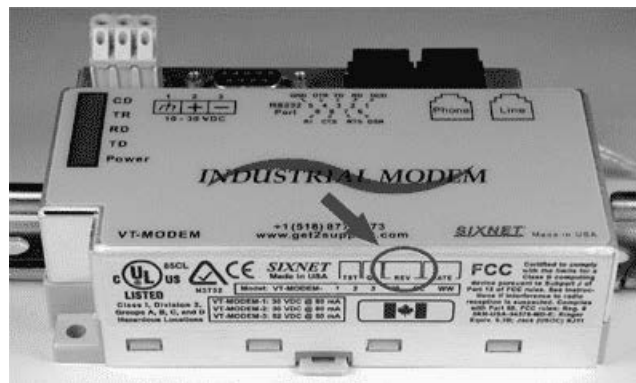

3. You can also detect the modem type using a terminal program. To query the firmware version enter `ati3<enter>`. Please see the tables below for information on how to interpret this firmware rev number.

VT-MODEM-1			
VT-MODEM WIZARD	REV 1	REV 2	REV 3
Back Label	1.00-1.08, 1.10-2.02	1.09	3.00 and above
Terminal (ati3)	V2.100-V34_2M_DLS	P2109-V90	CX81802-V34 OR CX93001-EIS_V0.2013-V34
VT-MODEM-2			
VT-MODEM WIZARD	REV 1	REV 2	REV 3
Back Label	1.00-1.04, 1.06-1.08	1.04/1.05	2.00 and above
Terminal (ati3)	V2.100-V34_2M_DLS	P2109-V90	CX81802-V34 OR CX93001-EIS_V0.2013-V34
VT-MODEM-3			
VT-MODEM WIZARD	REV 1	REV 2	REV 3
Back Label	1.00-1.02, 1.04-1.06	1.02/1.03	2.00 and above
Terminal (ati3)	V2.100-V34_2M_DLS	P2109-V90	CX81802-V34 OR CX93001-EIS_V0.2013-V34

1.3 VT-MODEM-2 Self-Dialing Feature

The Self-Dialing Modem is triggered by a switch closure or PLC output signal. It dials a pre-stored phone number and optionally identifies itself by way of a pre-stored ASCII message. Flexible features allow this modem to perform retries or even connect to alternate number until it has verified that a connection has been established. The call will terminate when either:

- The computer completes its polling and hangs up
- The modem discrete input is turned off
- A telephone line problem disrupts the call.

The VT-MODEM-2 enables field installed equipment to establish a telephone link based upon a simple switch closure. This self-dialing modem adds “dial upon alarm” intelligence to any remote site. This enhanced modem is ideal for:

1.3.1 Dialing Upon Alarm From Any PLC

This modem establishes a connection based upon a coil output from any PLC. Once a connection has been established, the PLC’s system (programming) port is connected to the computer at the other end of the phone link and may be polled by that computer as if the computer had initiated the call. When the modem connects to the central computer, it identifies itself so the computer can run the appropriate I/O driver and interrogate the PLC.

1.3.2 Sending A Message Based Upon A Switch Contact

Locations that do not have PLCs (or other intelligence) can originate calls to alert you to low tank levels, over temperature conditions, or other alarms. Simply connect the appropriate alarm contact to the modem’s input. The modem will dial the pre-stored phone number and deliver the ID message to the computer at the receiving end.



1.4 VT-MODEM-3 RS485 Port

The VT-MODEM-3 Industrial Modem Plus has an RS422 / RS485 port that can function in place of its RS232 port. The RS422 / RS485 port supports RS422 and RS485 full duplex and two wire RS485 half duplex communication to compatible devices. The VT-MODEM-3 is user-configurable to communicate through either the RS232 port (VT-MODEM-1 mode) or through the RS422 / RS485 port. Only one port can be used at a time.

1.5 VT-MODEM SETUP WIZARD

A modem setup utility is provided at www.redlion.net to help you quickly configure any Sixnet Industrial Modem. In most applications, no knowledge of modem AT commands or S register contents is necessary. Pre-configured profiles, for common situations are provided for your convenience. An extensive online help file is provided with this utility.

1.6 Product Highlights

1.6.1 VT-MODEM 1-3

- Rated for -30° to +70°C operation
- Proven in the toughest settings from pipelines in Alberta to remote locations in Sweden
- DIN Rail or flat panel mounting
- Supports all PLCs, RTUs and other devices
- Compliant with telephone systems world-wide.

1.6.2 VT-MODEM-1 Features and Benefits

FEATURES AND BENEFITS

Workhorse for general industrial applications

- Supports baud rates up to 33.6K (V.34)

1.6.3 VT-MODEM-2 Features and Benefits

FEATURES AND BENEFITS

Functionality

- Dial-up and auto-answer
- Auto-dial on PLC output



1.6.4 VT-MODEM-3 Features and Benefits

FEATURES AND BENEFITS

RS422/RS485 port in addition to a RS232 port

Functionality

- Dial-up and auto-answer
- RS422/RS485 interface
- Extended power input (up to 52 VDC)

1.7 VT-MODEM Specifications

TELEPHONE LINE (ALL MODELS)	
Max. Data Range	33.6 kbps (V.34)
Compatibility	V.34, V.32bis, V.32, V.32, V.22bis, V.22A/B, V.23, V.21, Bell212A & 103
Data Compression	V.44/V.42 bis/MNP 5
Error Correction	V.42/MNP 2-4
Max. Fax Modem Rate	14.4 kbps (V.33)
Fax Modem Compatibility	Group 3 (V.33, V.17, V.29, V.27ter, V.21 ch. 2)
Ringer Equivalent	0.3
Line Jack	RJ11
Phone Jack	RJ11 (VT-MODEM-1 and -2)
RS232 PORT (ALL MODELS)	
Max. RS232 Rate	115.2 kbps (VT-MODEM-1WW only); 57600 bps (VT-MODEM-2WW and VT-MODEM-3WW)
RS232 Signal Support	TXD, RXD, CTS, RTS, DCD, DTR, DSR, RI, GND
RS232 Connector	DB9 female, RS232
Command Set	All standard AT and S register commands including Class 1, Class 2 Fax commands, and Voice commands
RS422/RS485 PORT (VT-MODEM-3 ONLY)	
RS422 Mode	4 wire full duplex
RS485 Modes	2 or 4 wire party-line operation (half duplex)
Signal Rate	Standard rates up to 57600 bps
RS422 / RS485 Distance	Up to 0.5 miles
STATUS LEDS (ALL MODELS)	
CD (Carrier Detect)	The modem has detected a carrier on the phone line (a remote modem has been detected).
TR (Data Terminal Ready)	The PC (or RTU/PLC) has established a connection to the modem and is ready.
RD (Receive Data)	Flashes as data is received from the phone line.
TD (Transmit Data)	Flashes as data is sent out the phone line.
Power	On when power is present.
GENERAL CHARACTERISTICS (ALL MODELS)	
Input Power	10 - 30 VDC (VT-MODEM-1, -2), 10 - 52 VDC (VT-MODEM-3)
Input Current (Rev 1 and Rev 2, see section 1)	65mA @ 24VDC and 26mA in Low Power mode of -1 (typical) 97mA @ 24VDC and 64mA in Low Power mode of -2 (typical) 68mA @ 24VDC and 28mA in Low Power mode of -3 (typical)
Input Current (Rev 3)	50mA @ 24VDC and 30mA in Low Power mode for -1 and -2 (typical) 55mA @ 24VDC and 35mA in Low Power mode for -3 (typical)
Certification	FCC Part 15 and FCC Part 68; UL 508; CSA C22.2/142; ACA TS 001- 1997; ACA TS 002-1997; AS/NZS3260-1993; AS/NZS3548-1995; CTR21 (98/482/EC); EN55022; EIEC 950:1991; Hazardous Locations: ANSI/ISA 12.12.01, CSA C22.2/213 (Class 1, Division 2 Groups A, B, C and D)



GENERAL CHARACTERISTICS (ALL MODELS)	
Operating Temperature	-30° to 70° C
Storage Temperature	-40° to 85° C
Humidity	5 to 95% RH (non-condensing)
Mounting	DIN rail or panel mount
Dimensions	W x 4.75L x 1.35H inches (8.2 W x 12.1 L x 3.4H cm)
PLC DISCRETE I/O INTERFACE (VT-MODEM-2 ONLY)	
Trigger Input (From PLC)	Connects to PLC output. Starts auto-dialing upon transition from OFF to ON. Modem will stay connected while input is ON.
Voltage Range	9 - 30 VDC
Input Current	6.5 mA at 24 VDC
Max. OFF Voltage	5 VDC
On-line Output (To PLC)	Output is ON as long as a connection exists (carrier detect).
Output Characteristics	Sourcing - switches supply power
Max. Output Current	100 mA

Chapter 2 Hardware Installation

2.1 Mounting the VT-MODEM

The VT-MODEM snaps onto standard DIN rail (DIN EN 50022) or is mounted to a flat panel using #6 or #8 screws. See the image below. The modem can be installed in any orientation, directly adjacent to other DIN rail components or in any convenient location within the enclosure. The modem should be installed within 6 feet of the device it will be connected to.

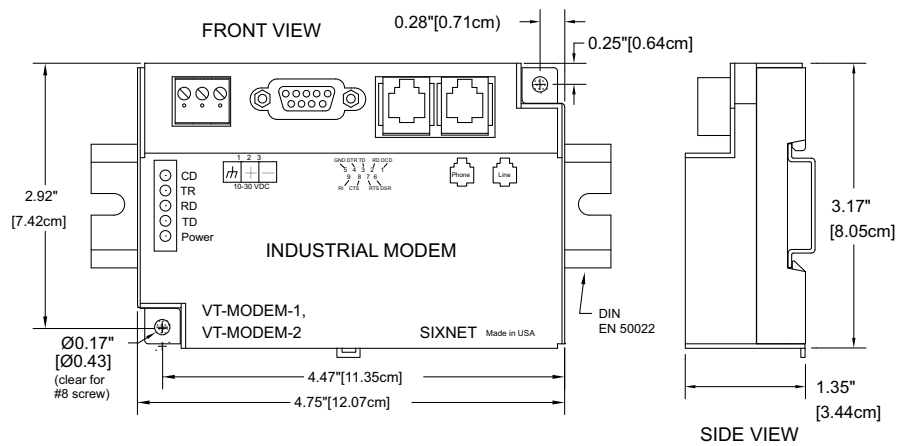

For DIN rail mounting, hook the top, rear of the modem onto the top edge of the DIN rail. Using a small flathead screwdriver, pull down on the spring-loaded tab on the bottom of the modem and push the modem back against the rail. Reverse these steps to remove the modem. See the image below.

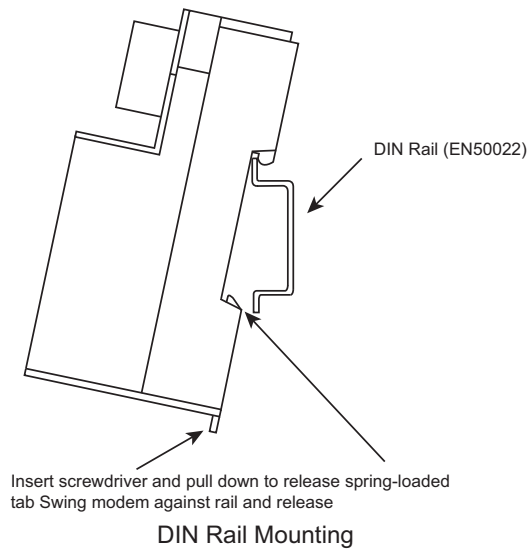

2.2 Electrical Connections

2.2.1 RS232 Connections

Use the Sixnet[®] RS232 cable (VT-CABLE-MDM, which is 6 feet in length) or an equivalent cable to connect the modem's RS232 port (DB9 Male cable end) to the RS232 port on the SixTRAK[®] Gateway, VersaTRAK[™] RTU, or PC (DB9 Female cable end). As shown in 2.2.1.1, the VT-CABLE-MDM is a straight through serial communications cable suitable for connecting a DTE device (PC, Gateway or VersaTRAK) to a DCE device (VT-MODEM). For IPm[®] and ST-GT-1210 stations, use a straight-through Ethernet cable (not supplied) and the RJ45 to DB9 male adapter that comes with the station.

Cable requirements for PLCs and other devices may be different. Refer to the PLC or other device's documentation for cable pin-outs. Some PLC cables are documented in the Technical notes provided by Red Lion technical support.

Note: The technical notes are not listed here.

VT-CABLE-MDM

Cable for VT-MODEM to IBM COM Port
or SIXTRAK / VersaTRAK RS232 Port

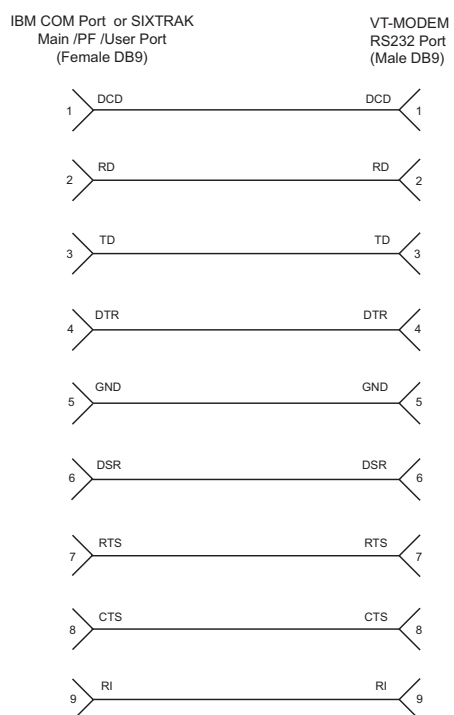

2.2.2 VT-MODEM-1 Power, Phone Line Connections

2.2.2.1 DC Power Wiring

Connect 10 - 30 VDC to the VT-MODEM-1 as shown in the image below. The modem can usually be powered from the same DC source as other devices in the enclosure. All the screw terminals should be tightened to a maximum of 3.48 in-lbs.

2.2.2.2 Telephone Cable

Connect analog phone lines to the RJ-11 jacks as appropriate. One RJ-11 jack is provided to connect directly to a telephone (optional) and the second RJ-11 jack functions as the connection to the telephone network.

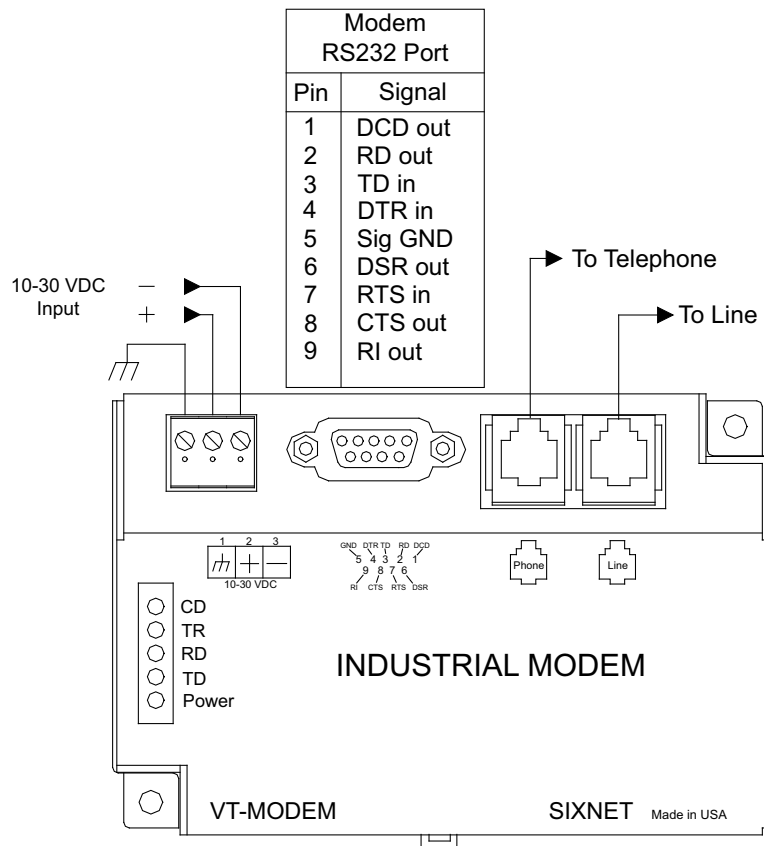

2.2.3 VT-MODEM-2 Power, Phone Line, Self-Dial Connections

2.2.3.1 DC Power Wiring

Connect 10 - 30 VDC to the VT-MODEM-2 as seen in the image under "PLC Self-Dial I/O Connections". The modem can usually be powered from the same source as other devices in the enclosure. All the screw terminals should be tightened to a maximum of 3.48 in-lbs.

2.2.3.2 Telephone Cable

Connect analog phone lines to the RJ-11 jacks as appropriate. One RJ-11 jack is provided to connect directly to a telephone (optional) and the second RJ-11 jack functions as the connection to the telephone network.

2.2.3.3 PLC Self-Dial I/O Connections

Connect a 10 - 30 VDC signal to the 'From PLC' (trigger input) terminal. An OFF to ON transition of this signal starts the auto-dialing sequence. The modem will call and remain connected while the signal is ON. When the signal goes false, the modem will terminate the connection or the call in progress.

The 'To PLC' (on-line output) terminal will go ON (ON = user supplied VDC input) when a modem to modem connection has been established and the proper 'Acknowledge Message' has been received.

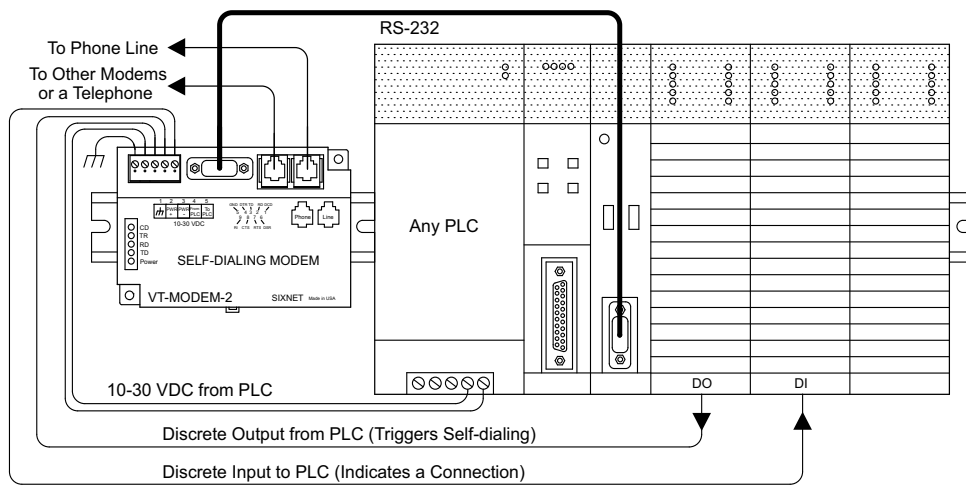

2.2.4 VT-MODEM-3 Power, Phone Line, RS422 / RS485 Connections

2.2.4.1 DC Power Wiring

Connect 10 - 52 VDC to the VT-MODEM-3 as shown in the image in "RS422 / RS485 Cabling and DIP Switch Settings". The modem can usually be powered from the same source as other devices in the enclosure. All the screw terminals should be tightened to a maximum of 3.48 in-lbs.

2.2.4.2 Telephone Cable

Connect an analog phone line to the RJ-11 jack as appropriate.

2.2.4.3 RS422 / RS485 Cabling and DIP Switch Settings

Refer to the image below for typical wiring configurations. Fabricate a cable to connect the modem's RS422 / RS485 port to the field device(s).

The VT-MODEM-3 has DIP switches. These switches establish the mode of operation for the RS422 / RS485 port. Set these switches to match the type of wiring connected to the RS422 / RS485 port. Refer to the images on pages 2-12, 2-13 and 2-14. It is not necessary to cycle power to the modem if DIP switch changes are made.

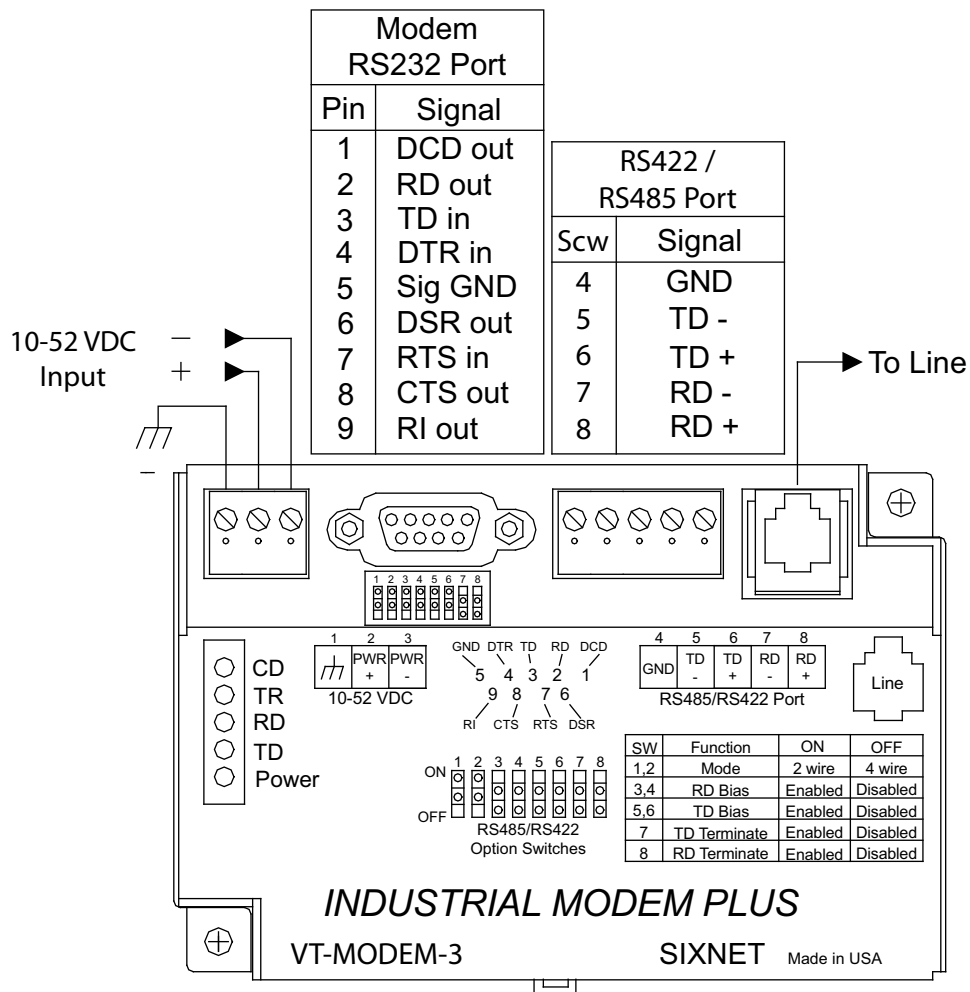

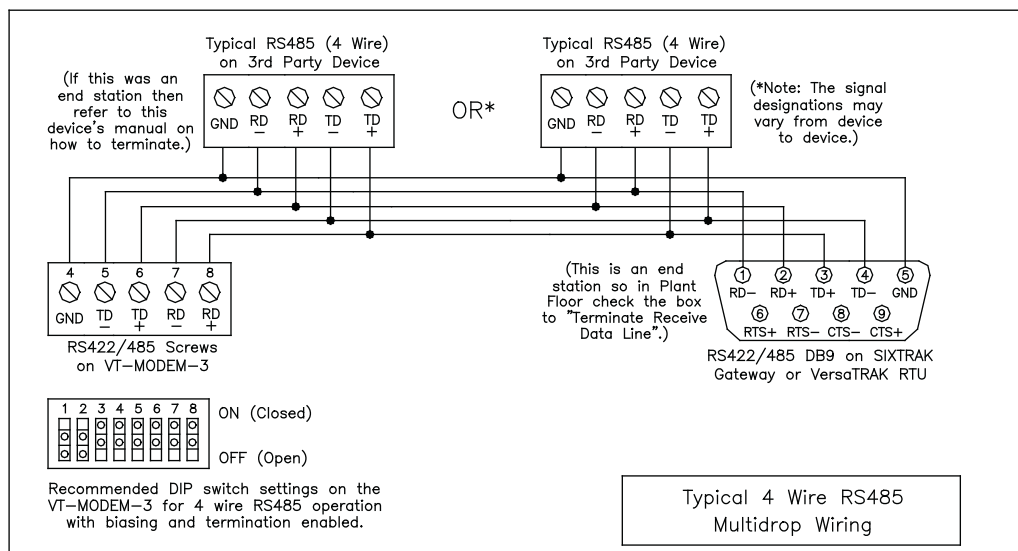
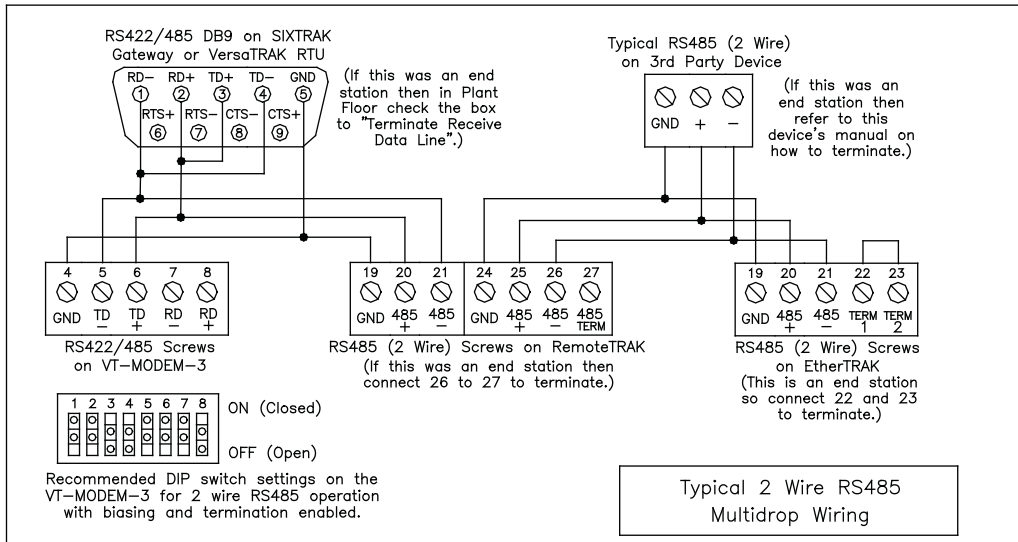

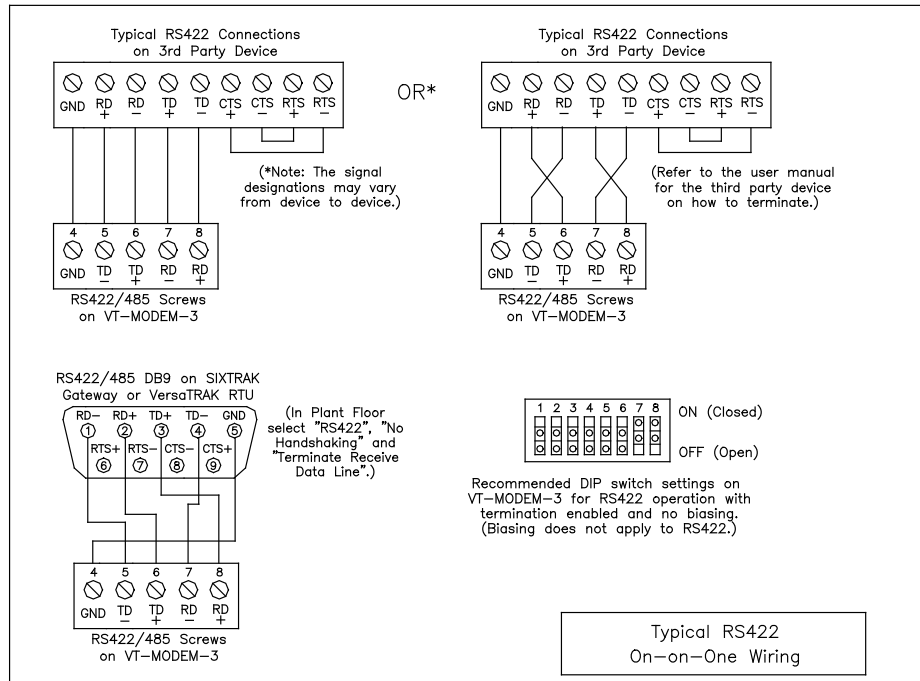

2.2.4.4 VT-MODEM-3 DIP Switch Summary

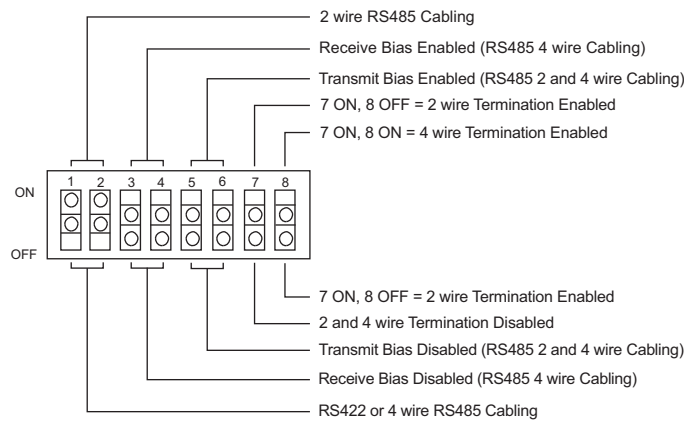

2.2.4.5 RS422 / RS485 Network Termination

The VT-MODEM-3 has built-in termination components for the Receive Data and Transmit Data signals. Termination of these signals is enabled by setting DIP switches on the VT-MODEM-3. Termination components are often built into other RS422 / RS485 devices, and are typically enabled by setting a jumper or DIP switch on the appropriate device.

Here are some guidelines for the use of termination:

- Terminations should be enabled at both ends of an RS422 communication cable.
- Terminations should be enabled at both end stations on a RS485 network. No more than two stations should be terminated on a RS485 network.

2.2.4.6 Bias Resistors (RS485 Networks Only)

On an RS485 two wire network there should be one pair of bias resistors acting upon the transmit/receive wires. On an RS485 four wire network there should be two pairs of bias resistors; one pair on the receive wires and one pair on the transmit wires. Bias resistors force the receive or transmit/receive wires to a known (non-floating) state when none of the RS485 devices are transmitting data. If bias resistors are not present, some RS485 devices may experience communication errors due to noise on the floating wires. Bias resistors do not apply to RS422 wiring because the wires are always driven by the two RS422 devices. The wires are not permitted to float.

The location of the bias resistors is not critical. Typically they are installed at the master RS485 device. Bias resistors are provided in the VT-MODEM-3 and are enabled through DIP switch settings. There should be only one pair of these resistors connected to an RS485 two wire network, and only two pairs of these resistors connected to an RS485 four wire network. Refer to the RS485 and RS422 images in section 2.2.4.3 for recommended VT-MODEM-3 DIP switch settings. Do not enable the VT-MODEM-3 bias resistors if there are bias resistors enabled on one of the other RS485 devices.

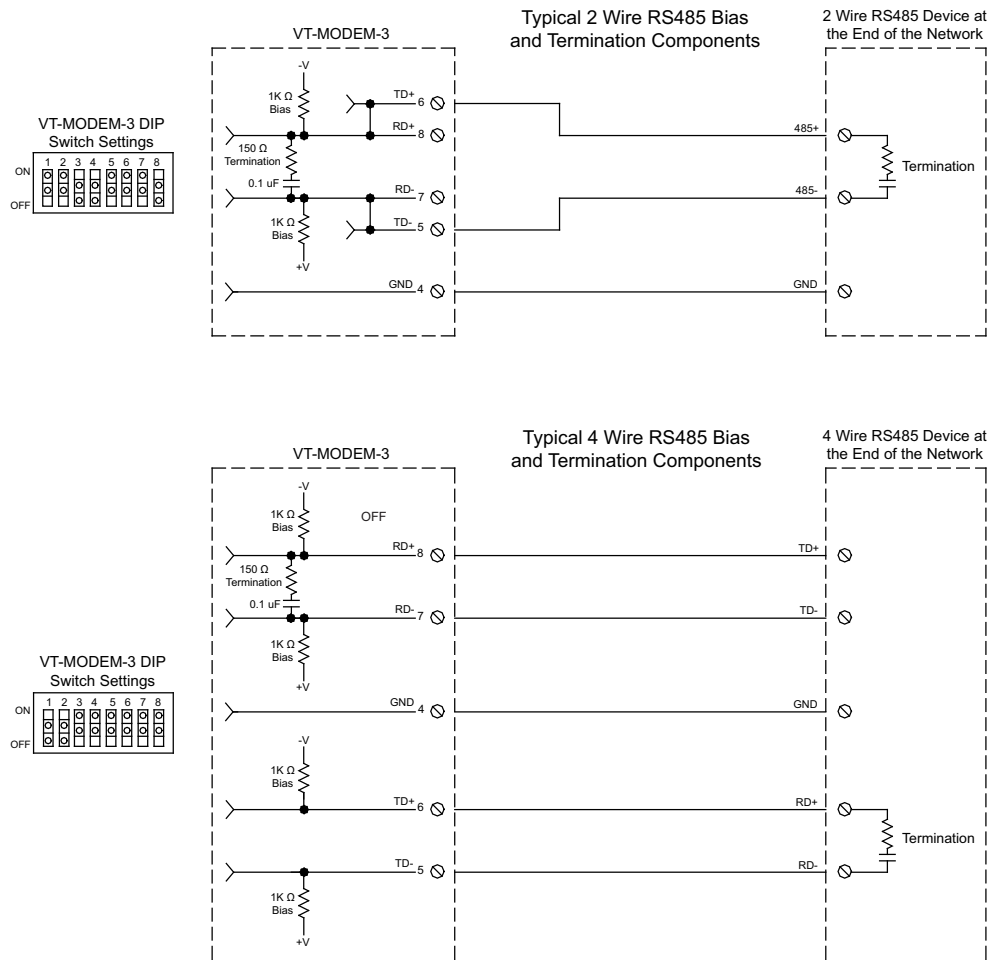

2.2.4.7 Configuring a PC Modem to Communicate with a VT-MODEM-3 in RS422 or RS485 Mode

It may be necessary to change your PC's modem settings when communicating with a VT-MODEM-3 running in RS422 or RS485 mode. The PC modem, VT-MODEM-3, and the modem-to-modem speed should all be set to the same rate.

2.3 Modem Configuration

2.3.1 Configuring a VT-MODEM

All VT-MODEM models are factory configured to use the default communication settings for SIXTRAK Gateways and VersaTRAK RTUs. If a VT-MODEM is connected to a PLC, PC or other non-Sixnet device, then it may be necessary to reconfigure the modem. See the upcoming sections for further details.

2.3.1.1 AT Command String At Power-up

Upon powerup, a SIXTRAK gateway or VersaTRAK RTU can send a command string to a VT-MODEM. This capability can be used to assure that the modem is set to a particular mode of operation, such as auto answer mode. Refer to the “Set Modem String” topic in the Plant Floor program’s online help for information on this capability. Any standard AT command can be sent by the gateway or RTU.

2.3.2 Configuring a VT-MODEM as an External Modem on a PC

The VT-MODEM can be connected directly to a PC. The modem will need to be “installed” in Windows prior to use. Here are instructions to install the modem in most recent Windows® Operating Systems.

2.3.2.1 Modem Installation in Windows® 10

1. Connect the DC power, communications cable (VT-CABLE-MDM or equivalent) and telephone line as described above.
2. In the search box next to the Windows button type “Phone and Modem” and select the Phone and Modem in Control Panel.
3. In the Modems tab, click the “Add” button. Do not select the “Don’t detect my modem, I will select it from a list”. Instead, click Next and allow Windows to search the com ports and detect the modem.
4. Windows should find a modem called Standard Modem. Click Next and Windows will complete installation of the Standard Modem. (Alternately, click Change and select “Standard Modem Types” from the Manufacturers list, and “Standard 28800 bps Modem” from the Models list.)
5. To verify that the modem has been installed, go to the “Phone and Modems” in Control Panel, then go to the “modems” tab. The modem should be listed as either a “Standard Modem” or a “Standard 28800 bps Modem” depending on the steps followed above.
6. Upon re-booting the machine, Windows may still find the VT-MODEM as new hardware. If this happens, select “Do not install a driver (Windows will not prompt again)”.

2.3.2.2 Modem Installation in Windows® 7

1. Select Start→Control Panel, and then double click the Phone and Modems icon.
2. In the Modems tab, click the “Add” button. Do not select the “Don’t detect my modem, I will select it from a list”. Instead, click Next and allow Windows to search the com ports and detect the modem.
3. Windows should find a modem called Standard Modem. Click Next and Windows will complete installation of the Standard Modem. (Alternately, click Change and select “Standard Modem Types” from the Manufacturers list, and “Standard 28800 bps Modem” from the Models list.)

4. To verify that the modem has been installed, go to the “Phone and Modems” in Control Panel, then go to the “modems” tab. The modem should be listed as either a “Standard Modem” or a “Standard 28800 bps Modem” depending on the steps followed above.
5. Upon re-booting the machine, Windows may still find the VT-MODEM as new hardware. If this happens, select “Do not install a driver (Windows will not prompt again)”.

Once the VT-MODEM has been added to your Windows system, it is ready for use.

If you are using Sixnet I/O, you can use the Sixnet Sixdial software to dial out and establish a connection with your Sixnet I/O. The Sixdial utility allows other Sixnet programs to perform operations such as data transfers, hardware configuration and diagnostics, and ISaGRAF programming. (Refer to the on-line help in the Sixdial utility for more information on these software tools).

If you are using a PLC or other device, refer to the documentation for that device as necessary.

2.3.3 To Remove a Modem

If it ever becomes necessary to re-install the modem for any reason, go to the “Phone and Modems” window in the Control Panel. In the “modems” tab, highlight the modem to be removed and click the Remove button. To reinstall the modem, follow the installation steps as previously described.

2.3.4 Configuring a VT-MODEM Using VT-MODEM Setup Wizard

It is highly recommended that the Sixnet VT-MODEM Setup Wizard be used for VT-MODEM configuration. Simply check the appropriate boxes, choose the appropriate communication settings from the dropdown lists, and load the configuration into the VT-MODEM. This utility does not require user knowledge of AT commands and S-registers.

Refer to the online help system in the VT-MODEM Setup Wizard for instructions and application notes.

Note: The VT-MODEM Setup Wizard must be used to configure the self dial parameters of the VT- MODEM-2 and the RS422 / RS485 port parameters of the VT-MODEM-3.

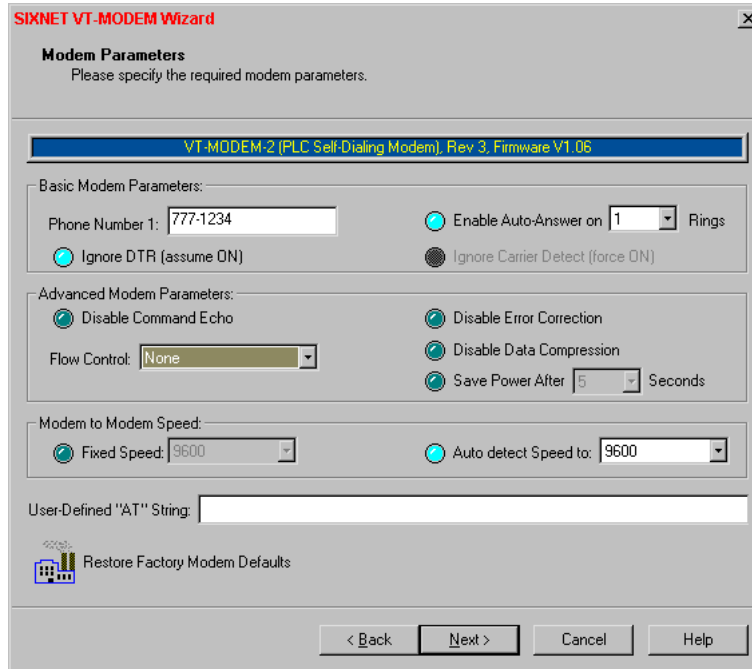

2.3.5 Setting the Modem's Baud Rate for the PLC

The VT-MODEM has an automatic baud rate detection feature that lets the modem recognize commands through its serial port at any supported baud rate. However, if the modem is connected to a device that does not send commands or data unless spoken to (such as most PLCs), then the modem will pass information from the phone line to its serial port at the last auto-detected baud rate. This is typically the baud rate used by the VT-MODEM setup Wizard when configuring the modem.

The VT-MODEM is defaulted at the factory for 9600-baud. To change this setting, connect the modem to a PC. Start the VT-MODEM setup Wizard and choose the baud rate that matches the PLC's baud rate. Then choose the appropriate settings and write the configuration to the modem. Exit the VT-MODEM setup Wizard and reconnect the modem to the PLC. (Be sure to cycle power to the modem.) Call the modem and verify that the PLC is responding to commands.

2.3.6 Limiting the Phone Line Connection Speed for Reliability

Typically, when a modem-to-modem connection is established, the two modems negotiate and connect at the fastest possible phone line speed that is within the capability of both modems. The quality of the phone line connection (during the negotiation) will be taken into account. If both modems are of a modern design (such as the VT-MODEM), the phone line speed can be 33.6K bits per second (or higher, using data compression). Note that this phone line speed is independent of the DTE (serial port) speed, though some older modems require that the phone line speed and DTE speed be the same.

In practice the quality of any phone line changes continually, and frequent data errors may occur. The probability of errors usually increases as the phone line speed increases. Therefore, it is often desirable to restrict the phone line speed to a rate that will provide good performance and yield reliable data. It is also commonplace to restrict the phone line speed to maintain compatibility when replacing an older modem with the VT-MODEM.

By default, the VT-MODEM will permit any phone line speed up to 115.2 kbps when data compression is enabled. If you experience intermittent or unreliable communication, try setting the modem-to-modem speed (in the VT-MODEM Setup Wizard) to a lower value, to restrict the phone line speed. (Remember to load the new configuration to the modem.)

2.3.7 VT-MODEM Profile Summary

Here is a summary of the active configuration, user profile 0, user profile 1 and the factory defaults when the modem is shipped. Each time the modem is powered up, first the factory default settings (as listed in Section 6) are loaded into the active configuration. Next, the designated user stored profile is loaded into the active configuration. User profile 0 is loaded by default (see the &Y command in Section 6) and it contains all factory defaults with the exception that it is set to auto answer (register S0=1), and ignore DTR (&D0).

The User profile 1 contains all normal factory defaults (as listed in Section 2.4).

ACTIVE PROFILE:

B1 E1 L1 M1 N0 Q0 T V1 W0 X4 Y0 &C1 &D0 &G0 &J0 &K3 &Q5 &R1 &S0 &T5 &X0 &Y0 S00:001 S01:000
S02:043 S03:013 S04:010 S05:008 S06:002 S07:050 S08:002 S09:006

S10:014 S11:085 S12:050 S18:000 S25:005 S26:001 S36:007 S38:020 S46:138 S48:007 S95:000

STORED PROFILE 0:

B1 E1 L1 M1 N0 Q0 T V1 W0 X4 Y0 &C1 &D0 &G0 &J0 &K3 &Q5 &R1 &S0 &T5 &X0 S00:001 S02:043 S06:002
S07:050 S08:002 S09:006 S10:014 S11:085 S12:050 S18:000 S36:007 S40:104 S41:195 S46:138 S95:000

STORED PROFILE 1:

B1 E1 L1 M1 N0 Q0 T V1 W0 X4 Y0 &C1 &D2 &G0 &J0 &K3 &Q5 &R1 &S0 &T5 &X0 S00:000 S02:043 S06:002
S07:050 S08:002 S09:006 S10:014 S11:085 S12:050 S18:000

FACTORY DEFAULTS:

B1 E1 L1 M1 N0 Q0 T V1 W0 X4 Y0 &C1 &D2 &G0 &J0 &K3 &Q5 &R1 &S0 &T5 &X0 &Y0 S00:000 S01:000
S02:043 S03:013 S04:010 S05:008 S06:002 S07:050 S08:002 S09:006

S10:014 S11:085 S12:050 S18:000 S25:005 S26:001 S36:007 S38:020 S46:138 S48:007 S95:000



2.4 AT Command Summary

All VT-MODEM models support the AT commands, Fax Class 1 and Class 2 commands listed in this Section. The VT-MODEM contains a set of factory default settings, which can always be restored by the user. (See the &F command.) The modem also provides two user profiles (profile 0 and profile 1) which hold settings as set and saved by the user. (See the &W command.) The settings currently in use by the modem are generally referred to as the active configuration.

Note: VT-MODEM-2 self-dial parameters and VT-MODEM-3 RS422 / RS485 port parameters can only be set using the VT- MODEM SETUP Wizard. To download the VT-MODEM- SETUP Wizard, go to www.redlion.net/resources/software/sixnet-software/automation-devices-software-firmware.

The following tables only list the AT commands supported by the current modem firmware. For a complete list of AT commands, all valid parameters, and default settings for each AT command please see the Sixnet online help system of the VT-MODEM Setup Wizard.

Commands marked with an asterisk (*) have different characteristics, depending on the revision of VT- MODEM being used. Refer to the online help system of the VT-MODEM Setup Wizard for the details of these differences.

COMMAND	FUNCTION
A/	Re-execute Last Command; do not precede with AT command and do not follow with a carriage return.
A	Go off hook and Answer A Call
AT=x	Write value x to last selected register.
AT?	Report the value of last selected register.
Bn	Set data standard to CCITT (Europe et. al.) or Bell Mode (U.S., Canada) for connections at 300 or 1200 bps.
Cn	Carrier Control (parameter = 1 only)
Dn	Dial (originate a call); typical usage: ATDT5551212 to tone dial number. ATDS=n to dial nth stored number.
E	Echo command to monitor when typed
Fn	Not available.
Hn	Disconnect (Hang up)
In	Identification; reports product code, name, ROM and firmware data, etc.
Ln	Speaker Volume (not available)
Mn	Speaker Control (not available)
*Nm	Automode Enable; enabled allows connection at highest possible modem speed, disabled fixes speed according to register S37.
On	Return To On-line Data Mode
P	Set Pulse Dial Default.
Qn	Quiet Results Codes Control; when enabled, result codes are reported to the monitor.
Sn	Establishes S Register n as the last register accessed
Sn-x	Write value x to S Register n.
Sn?	Reports the value of S Register n.
T	Set Tone Dial Default

COMMAND	FUNCTION
Vn	Set Result Code Format to terse or verbose.
Wn	Connect Message Control sets the format of the connect messages.
Xn	Extended results code
Yn	Long space disconnect
Zn	Perform Soft Reset and Restore stored user configuration profile 0 or 1.
&Cn	RLSD (DCD) Option; set DCD signal to indicate presence of carrier or forces DCD signal on at all times.
&Dn	DTR Option; set how modem interprets the DTR signal.
&Fn	Restore factory configuration profile 0 or 1.
&Gn	Select guard tone
&Jn	Telephone jack control
&Kn	Set Flow Control
* &Mn	Asynchronous/synchronous mode selection
&Pn	Select pulse dial make/break ratio
* &Qn	Asynchronous/synchronous mode selection
&Rn	RTS/CTS option sets how the modem controls the CTS signal
&Sn	DSR Override sets how the modem controls the DSR signal
&Tn	Test & diagnostic settings
&V	Display current configuration, stored user profiles and stored telephone numbers
&V1	Display last connection statistics
&Wn	Store current active configuration in one of the two user profiles
&Xn	Select synchronous clock source
&Yn	Designate a default-reset profile. This profile will be active after a hard reset
* &Zn=x	Store phone number; n = 0 to 3 and x = dial string
%E	Enable/disable line quality monitor and autoretrain or fallback/fail forward
%L	Report line signal level
%Q	Report line signal quality
%7	Plug and Play Serial Number
%8	Plug & Play Vendor ID, Prod. No.
\Kn	Break Control sets how the modem responds to a break signal
\Nn	Sets the Operating Mode of the modem: direct, normal, reliable or auto reliable
\Vn	Single Line Connect Message Enable
\An	Select Max MNP Block Size
\Bn	Transmit Break to Remote sets the length of break signal sent to remote modem (in non error correction mode)
* +MS	Select Modulation allows control of the modulation the modem uses to negotiate a connection
* +VDR	Enable/disable distinctive ring
* +GCI	Country Select



COMMAND	FUNCTION
* +A8E	V.8 and V.8bis Operation Controls
%Cn	Enable/Disable Data Compression (MNP5, V42bis or both)
) Mn	Enable Cellular Power Level Adjust (only included for compatibility and performs no function)
@Mn	Initial Cellular Power Level Setting (only included for compatibility and performs no function)
:E	Compromise Equalizer Enable (only included for compatibility and performs no function)
*B	Display Blacklisted Numbers
*D	Display Delayed Numbers
-Kn	MNP Extended Services
#UD	Last Call Status Report
VOICE COMMANDS	
A	Answering in Voice/Audio Mode.
D	Dial command in Voice/Audio Mode.
H	Hang up in Voice/Audio Mode.
Z	Reset from Voice/Audio Mode.
* #BDR	Select baud rate (turn off autobaud). Enable/Disable RPI and DTE Speed
#CID	Enable Caller ID detection and select reporting format.
#CLS	Select data, fax, or voice/audio.
#MDL?	Identify model.
#MFR?	Identify manufacturer.
#REV?	Identify revision level.
#TL	Audio output transmit level.
#VBQ?	Query buffer size.
#VBS	Bits per sample (ADPCM or PCM).
#VBT	Beep tone timer.
#VCI?	Identify compression method (ADPCM).
#VLS	Voice line select (ADPCM or PCM).
#VRA	Ringback goes away timer (originate).
#VRN	Ringback never came timer (originate).
#VRX	Voice Receive Mode (ADPCM or PCM).
#VSD	Enable silence deletion (voice receive, ADPCM).
#VSK	Buffer skid setting.
#VSP	Silence detection period (voice receive, ADPCM).
#VSR	Sampling rate selection (ADPCM or PCM).
#VSS	Silence detection tuner (voice receive, ADPCM).
#VTD	DTMF tone reporting capability.
#VTM	Enable timing mark placement.
#VTS	Generate tone signals.



COMMAND	FUNCTION
#VTX	Voice transmit mode (ADPCM or PCM).
* Caller ID:	
+VCID	Enabling and configuring parameters of Caller ID detection.
SYNCHRONOUS ACCESS MODE:	
* +ES	Enable/Disable Synchronous Access Mode in the client or central site modem
+ESA	Configures the Operation of the Synchronous Access Submode
+ITF	Selects Transmit Flow Control Thresholds
FAX COMMANDS	
*+FCLASS	Select Active Service Class
*+FAA	Auto answer enable
*+FAE	Auto answer enable
*+FTS	Stop transmission and pause
*+FRS	Wait for silence
*+FTM	Transmit data with <mod> carrier
*+FRM	Receive data with <mod> carrier
*+FTH	Transmit HDLC data with <mod> carrier
*+FRH	Receive HDLC data with <mod> carrier
*+FAR	Adaptive reception control
*+FCL	Carrier loss timeout
*+FDD	Double escape character replacement control
*+FIT	DTE inactivity timeout
*+FPR	Fixed DTE Rate
*+FMI?	Report manufacturer ID
*+FMM?	Report model ID
*+FMR?	Report revision ID
*+FLO	Flow Control



2.5 S Register Summary

Note: The following tables only summarize the supported S-registers. A description for each S-register may be found in the online help system of the VT-MODEM Setup Wizard

REGISTER	FUNCTION	RANGE	UNITS	DEFAULT
S0	Number of rings required before modem auto answers	0-255	rings	0
S1	Ring counter increments each time a ring is detected	0-255	rings	0
S2	Escape character	0-255	ASCII	43
S3	Carriage return character	0-127	ASCII	13
S4	Line feed character	0-127	ASCII	10
S5	Backspace character	0-255	ASCII	8
S6	Maximum time to wait after going off-hook to dial when blind dialing	2-255	sec	2
S7	Maximum time to wait for carrier after dialing before hanging up	1-255	sec	50
S8	Pause time for dial delay modifier	0-255	sec	2
S9	Carrier detect response time; duration that carrier must be present for modem to consider it a valid connection	1-255	0.1s	6
S10	Carrier loss disconnect time; carrier must be absent for this time for modem to consider it a lost connection	1-255	0.1s	14
S11	DTMF tone duration	50-255	0.001s	95
S12	Escape prompt delay; this delay must be present after receipt of the last character of the escape sequence (before receipt of any other character) for the escape sequence to be recognized	0-255	0.02s	50
S13	Reserved	-	-	-
S14	General bit mapped options indicates the status of the following options: echo, quiet mode, results codes, tone/pulse and originate/answer	-	-	138(8Ah)
S15	Reserved	-	-	-
S16	Test mode bit mapped options (&T)	-	-	0
S17	Reserved	-	-	-
S20	AutoSync HDLC Addr or BSC Sync Char	0-255	-	0
S21	V24/general bit mapped options indicates the status of the following options: CTS(&Rn), DTR(&Dn), DCD(&Cn), DSR(&Sn), long space disconnect(Yn)	-	-	52(34h)
S22	Speaker/results bit mapped options indicates the status of the following options: speaker control(Ln), volume(Mn), results codes(Xn)	-	-	117(75h)
* S23	General Bit Mapped Options	-	-	58(3Ah)

REGISTER	FUNCTION	RANGE	UNITS	DEFAULT
S24	Sleep inactivity timer sets the length of time that the modem will operate in normal mode without activity on the phone or RS232 port before entering sleep mode	0-255	s	0
S25	Delay to DTR (CT108) off sets time modem ignores DTR signal before taking action specified by &Dn	0-255	s/0.01s	5
S26	RTS-to-CTS (CT105 to CT106) delay if &R0 is set	0-255	0.01s	1
S27	General Bit Mapped Options for sync/async control(&Mn/&Qn), leased line control(&Ln), clock select(&Xn), Bell/CCITT mode(Bn)	-	-	73(49h)
S28	General Bit Mapped Options indicates options for pulse dialing(&Pn), MNP Link negotiation speed(*Hn)	-	-	0
S29	Flash Modifier Time sets the length of time the modem will go on hook if the flash dial modifier(!) is encountered in the dial string	0-255	10 ms	70
S30	Inactivity timer sets the length of time the modem will remain on line if no data is sent or received	0-255	10s	0
S31	General Bit Mapped Options	-	-	194(C2h)
S34-S35	Reserved	-	-	-
S36	LAPM Failure Control used when register S48=128	-	-	7
S38	Delay before forced hang-up (time delay between the receipt of H command to disconnect and the actual disconnect operation)	0-255	s	20
S39	Flow control bit mapped options	-	-	3
S40	General bit mapped options	-	-	104(68h)
S41	General bit mapped options	-	-	195(C3h)
S42-S45	Reserved	-	-	-
S46	Enable/Disable Data Compression	-	-	138
S48	V.42 Negotiation Control	-	-	7
S82	LAPM Break Control	-	-	128(40h)
S86	Call Failure Reason Code; when the No Carrier result code is issued, the reason for the failure is written to this register	0-255	-	-
S91	PSTN transmit attenuation level	0-15	dBm	10
S92	Fax transmit attenuation level	0-15	dBm	10
S95	Result code messages control	-	-	0
S210	V.34 Symbol Rate	0-255		13 (0Dh)

2.6 Maintenance Information

2.6.1 Troubleshooting Tips

2.6.2 VT-MODEM Default LED Indications

All VT-MODEM models have the following LEDs.

LED	DEFAULT INDICATION
Carrier Detect	This LED will come ON once a phone line connection has been established, and will remain on for as long as the connection is maintained.
Data Terminal Ready	This LED should be ON at all times.
Receive Data	This LED will come ON whenever data is received through the phone line.
Transmit Data	This LED will come ON whenever the modem sends characters out the phone line.
Power LED	<p>Normal Indication (All models): This LED will be ON when power is applied to the modem.</p> <p>Additional States (VT-MODEM-2 only): A “Slow” blink indicates an invalid configuration or that the “Block COM Port Until Connected” feature is enabled. A “Fast” blink indicates that a self-dial is in process or that the modem is in “Configure Self-dialing Parameters” mode.</p>

Note: The RD and TD LEDs indicate the flow of characters in and out of the phone line interface of the VT-MODEM, and are not directly connected to the RS232 port (all models) or RS422 / RS485 port (VT-MODEM-3).

2.6.3 Reconnecting Serial Cables

It is important to cycle (remove and then reapply) DC power to a VT-MODEM each time the RS232 or RS422/RS485 cable is disconnected and then reconnected. The serial port of the modem may not function properly if power is not cycled.

2.6.4 Resetting the VT-MODEM (all models)

If it ever becomes necessary to completely reset the modem including both user profiles to the basic factory default settings, the following command can be issued:

```
AT&F&W&W1 [CR]
```

This command string will load the factory defaults into the active configuration (&F) and then save those settings into both user profile 0 (&W) and user profile 1 (&W1).

Note that after the modem is reset completely to the factory defaults, it will no longer be set to auto-answer, which is often necessary for the modem to work when connected to a remote device. Use the VT-MODEM Setup Wizard to adjust these settings appropriately.

Service and Support Information

3.1 Service Information

We sincerely hope that you never experience a problem with any Red Lion product. If you do need service, call Red Lion at 1-877-432-9908 for Technical Support. A trained specialist will help you quickly determine the source of the problem. Many problems are easily resolved with a single phone call. If it is necessary to return a unit to us, an RO (Repair Order) can be obtained on the [Red Lion website](#).

Red Lion tracks the flow of returned material with our RO system to ensure speedy service. You must include this RO number on the outside of the box so that your return can be processed immediately.

Be sure to have your original purchase order number and date purchased available.

We suggest that you give us a repair purchase order number in case the repair is not covered under our warranty. You will not be billed if the repair is covered under warranty.

Please supply us with as many details about the problem as you can. The information you supply will be written on the RO form and supplied to the repair department before your unit arrives. This helps us to provide you with the best service, in the fastest manner. Repairs are completed as soon as possible. If you need a quicker turnaround, ship the unit to us by air freight. We give priority service to equipment that arrives by overnight delivery.

We apologize for any inconvenience that the need for repair may cause you. We hope that our rapid service meets your needs. If you have any suggestions to help us improve our service, please give us a call. We appreciate your ideas and will respond to them.

For Your Convenience:

Please fill in the following and keep this manual with your Red Lion system for future reference:

P.O. #: _____ Date Purchased: _____

Purchased From: _____

3.2 Product Support

Technical Support:

Inside US: +1 877 432-9908
Outside US: +1 717 767-6511
E-mail: support@redlion.net

Customer Service:

Inside US: +1 877 432-9908
Outside US: +1 717 767-6511
E-mail: customer.service@redlion.net



Statement of Limited Warranty

(a) Red Lion Controls Inc.(the “Company”) warrants that all Products shall be free from defects in material and workmanship under normal use for the period of time provided in “Statement of Warranty Periods” (available at www.redlion.net) current at the time of shipment of the Products (the “Warranty Period”). **EXCEPT FOR THE ABOVE-STATED WARRANTY, COMPANY MAKES NO WARRANTY WHATSOEVER WITH RESPECT TO THE PRODUCTS, INCLUDING ANY (A) WARRANTY OF MERCHANTABILITY; (B) WARRANTY OF FITNESS FOR A PARTICULAR PURPOSE; OR (C) WARRANTY AGAINST INFRINGEMENT OF INTELLECTUAL PROPERTY RIGHTS OF A THIRD PARTY; WHETHER EXPRESS OR IMPLIED BY LAW, COURSE OF DEALING, COURSE OF PERFORMANCE, USAGE OF TRADE OR OTHERWISE.** Customer shall be responsible for determining that a Product is suitable for Customer’s use and that such use complies with any applicable local, state or federal law.

(b) The Company shall not be liable for a breach of the warranty set forth in paragraph (a) if (i) the defect is a result of Customer’s failure to store, install, commission or maintain the Product according to specifications; (ii) Customer alters or repairs such Product without the prior written consent of Company.

(c) Subject to paragraph (b), with respect to any such Product during the Warranty Period, Company shall, in its sole discretion, either (i) repair or replace the Product; or (ii) credit or refund the price of Product provided that, if Company so requests, Customer shall, at Company’s expense, return such Product to Company.

(d) **THE REMEDIES SET FORTH IN PARAGRAPH (c) SHALL BE THE CUSTOMER’S SOLE AND EXCLUSIVE REMEDY AND COMPANY’S ENTIRE LIABILITY FOR ANY BREACH OF THE LIMITED WARRANTY SET FORTH IN PARAGRAPH (a).**

