

# KOMATSU®

## WA470-6

**HORSEPOWER**

**Gross: 204 kW** 273 HP @ 2000 rpm

**Net: 203 kW** 272 HP @ 2000 rpm

**BUCKET CAPACITY**

**3.6–5.2 m<sup>3</sup>** 4.7–6.8 yd<sup>3</sup>

**ecot3**

**WA  
470**

**WHEEL LOADER**



Photo may include optional equipment.

# WALK-AROUND

## ***High Productivity & Low Fuel Consumption***

- High performance SAA6D125E-5 engine
- Low fuel consumption
- Dual-mode engine power select system
- Large-capacity torque converter
- Automatic transmission with shift timing select system
- Lock-up Torque Converter (optional)
- Variable displacement piston pump & CLSS

See pages 4 and 5.

## ***Excellent Operator Environment***

- Automatic transmission with ECMV
- Electronic controlled transmission lever
- Variable transmission cut-off system
- Telescopic / tilt steering column
- Fingertip control levers
- Low-noise designed cab
- Pillar-less large ROPS/FOPS integrated cab
- Easy entry/exit, rear-hinged door

See pages 8 and 9.



## ***Harmony with Environment***

- EPA Tier 3 and EU Stage 3A emissions certified
- Low exterior noise
- Low fuel consumption

### ***Increased Reliability***

- Reliable Komatsu designed and manufactured components
- Sturdy main frame
- Maintenance-free, fully hydraulic, wet disc service and parking brakes
- Hydraulic hoses use flat face O-ring seals
- Cation electrodeposition process is used to apply primer paint
- Powder coating process is used to apply main structure paint
- Sealed DT connectors for electrical connections

See page 6.

### **HORSEPOWER**

**Gross: 204 kW 273 HP @ 2000 rpm**

**Net: 203 kW 272 HP @ 2000 rpm**

### **BUCKET CAPACITY**

**3.6–5.2 m<sup>3</sup> 4.7-6.8 yd<sup>3</sup>**



Photo may include optional equipment.

### ***Easy Maintenance***

- “EMMS” (Equipment Management Monitoring System)
- Easy access, gull-wing type engine side doors
- Automatic Reversible Fan (optional)

See page 7.

# HIGH PRODUCTIVITY AND LOW FUEL CONSUMPTION



## High Performance SAA6D125E-5 Engine

Electronic Heavy Duty Common Rail fuel injection system provides optimum combustion of fuel. This system also provides fast throttle response to match the machine's powerful tractive effort and fast hydraulic response.

**Net: 203 kW 272 HP**

## Low Emission Engine

This engine is EPA Tier 3 and EU Stage 3A emissions certified, without sacrificing power or machine productivity.

## Low Fuel Consumption

The fuel consumption is reduced greatly because of the low-noise, high-torque engine and the large-capacity torque converter with maximum efficiency in the low-speed range.

## Dual-Mode Engine Power Select System

This wheel loader offers two selectable operating modes—E and P. The operator can adjust the machine's performance with the selection switch.

- **E Mode:** This mode provides maximum fuel efficiency for general loading.
- **P Mode:** This mode provides maximum power output for hard digging operation or hill climb.



Dual mode engine power selection switch



Eco indicator

The eco indicator will help an operator to promote energy saving.

## Large-capacity Torque Converter

Newly designed drive train has a large-capacity torque converter for optimal efficiency. The WA470-6 has plenty of acceleration without the need for full throttle and it can achieve high travel speeds, even on grades or steep ramps leading to feed hoppers. This significantly assists productivity and also delivers great value for load-and-carry operations.

## Automatic Transmission with Mode Select System

This operator controlled system allows the operator to select manual shifting or two levels of automatic shifting (low, and high). Auto L mode is for fuel saving operation with the gear shift timing set at lower speeds than Auto H mode.



Shift mode selection switch

Therefore Auto L mode keeps the engine in a relatively low rpm range for fuel conservation while yielding adequate tractive force by depressing the accelerator pedal.

## Lock-up Torque Converter (optional)

The Komatsu designed lock-up torque converter provides increased production efficiency, reduced cycle times and optimum fuel savings in load & carry or hill-climb operations. The operator can engage the system from 2nd to 4th gear. This optional feature allows the operator to activate the system on/off with a switch located on the right-side control panel.

## Variable Displacement Piston Pump & CLSS

New design variable displacement piston pump combined with the Closed-center Load Sensing System delivers hydraulic flow just as the job requires preventing wasted hydraulic pressure. Minimized waste loss contributes to better fuel economy.

- **New Variable Displacement Piston Pump:** The pump delivers only necessary amounts minimizing waste loss.

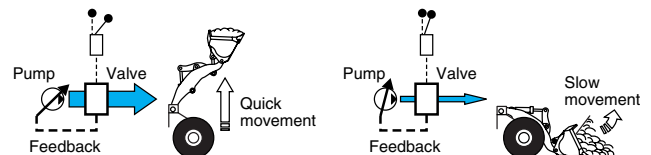

- **Fixed Displacement Piston Pump:** The pump delivers the maximum amount at any time and the unused flow is disposed.

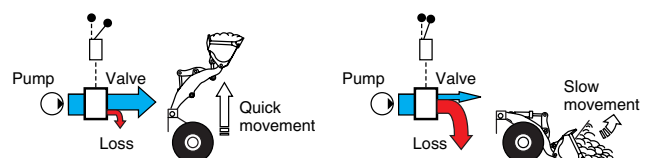



### Maximum Dumping Clearance and Reach

The long lift arms provide high dumping clearances and maximum dumping reach. The operator can even level loads on the body of a dump truck easily and efficiently.

**Dumping Clearance: 3185 mm 10'5"**

**Dumping Reach: 1235 mm 4'1"**

(4.2 m<sup>3</sup> 5.5 yd<sup>3</sup> bucket with B.O.C.)



## INCREASED RELIABILITY

### Komatsu Components

Komatsu manufactures the engine, torque converter, transmission, hydraulic units, electric parts, on this wheel loader. Komatsu loaders are manufactured with an integrated production system under a strict quality control system.

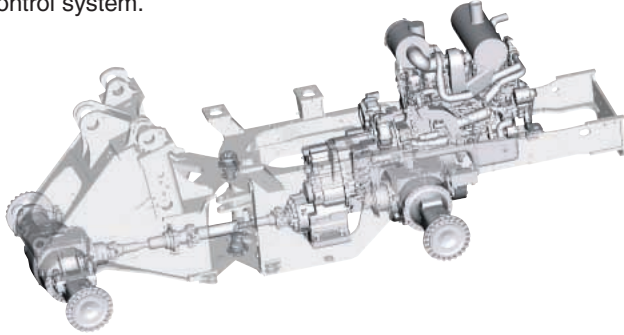

### Wet Multi-disc Brakes and Fully Hydraulic Braking System

mean lower maintenance costs and higher reliability. Wet disc brakes are fully sealed. Contaminants are kept out, reducing wear and maintenance. Brakes require no adjustments for wear, meaning even lower maintenance. The new parking brake is also an adjustment-free, wet multi-disc for high reliability and long life.

Added reliability is designed into the braking system by the use of two independent hydraulic circuits. Provides hydraulic backup should one of the circuits fail.

Fully hydraulic brakes mean no air system to bleed, or the condensation of water in the system that can lead to contamination, corrosion, and freezing.

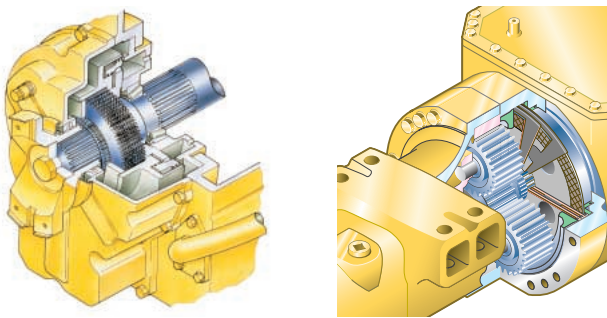

### High-rigidity Frames and Loader Linkage

The front and rear frames and the loader linkage have more torsional rigidity to secure resistance against increased stress due to the use of a larger bucket.

Frame and loader linkage are designed to accommodate actual working loads, and simulated computer testing proves its strength.

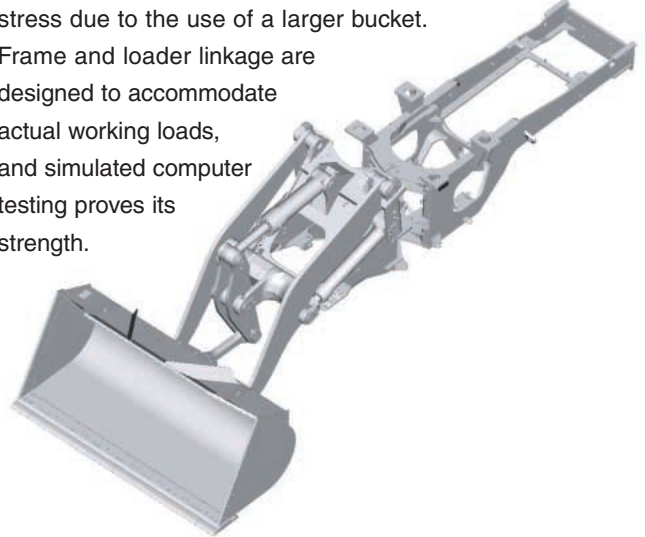

### Flat Face-to-face O-ring Seals

Flat face-to-face O-ring seals are used to securely seal hydraulic hose connections and to prevent oil leakage.

In addition, buffer rings are installed to the head side of the all-hydraulic cylinders to lower the load on the rod seals and maximize the reliability.

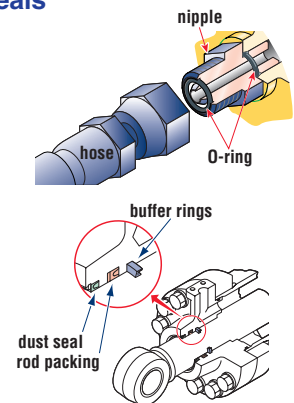

### Cation Electrodeposition Primer Paint/ Powder Coating Final Paint

Cation electrodeposition paint is applied as a primer paint and powder coating is applied as topcoat to the exterior sheet metal parts. This process results in a beautiful rust-free machine, even in the most severe environments. Some external parts are made of plastic providing long life and high impact resistance.

### Sealed DT Connectors

Main harnesses and controller connectors are equipped with sealed DT connectors providing high reliability, water resistance and dust resistance.



# EASY MAINTENANCE



Photo may include optional equipment.

## EMMS (Equipment Management Monitoring System)

Monitor is mounted in front of the operator for easy viewing, allowing the operator to easily check gauges and warning lights.



A specially designed two-spoke steering wheel allows the operator to easily see the instrument panel.

### Maintenance Control and Troubleshooting Functions

- **Action code display function:** If abnormality occurs, the monitor displays action details on the character display at the bottom center of the monitor.
- **Monitor function:** Controller monitors engine oil level, pressure, coolant temperature, air cleaner clogging, etc. If controller finds abnormalities, the error is displayed on LCD.
- **Replacement time notice function:** Monitor informs replacement time of oil and filters on LCD when replacement intervals are reached.
- **Trouble data memory function:** Monitor stores abnormalities for effective troubleshooting.

## Gull-wing Type Engine Side Doors Open Wide

The operator can open and close each gull-wing type engine side door easily with the assistance of a gas spring to perform daily service checks from the ground.



## Ease of Radiator Cleaning

If the machine is operating in adverse conditions, the operator can reverse the hydraulic cooling fan from inside the cab by turning on a switch on the control panel.

## Automatic Reversible Fan (optional)

The engine fan is driven hydraulically. It can be operated in reverse automatically. When switch is automatic position. The fan revolves in reverse for 2minutes every 2 hours intermittently. (Default setting)

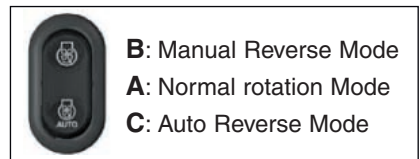

- B:** Manual Reverse Mode
- A:** Normal rotation Mode
- C:** Auto Reverse Mode

# OPERATOR ENVIRONMENT

## Easy Operation

### Automatic Transmission with ECMV

Automatic transmission with ECMV automatically selects the proper gear speed based on travel speed, engine speed, and other travel conditions. The ECMV (Electronically Controlled Modulation Valve) system engages the clutch smoothly to prevent lags and shocks when shifting. This system provides efficient machine operation and a comfortable ride.

- **Kick-down switch:**

Consider this valuable feature for added productivity. With the touch of a finger, the kick-down switch

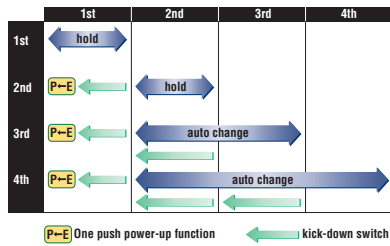

automatically downshifts from second to first when beginning the digging cycle. It automatically upshifts from first to second when the direction control lever is placed in reverse. This results in increased rim pull for better bucket penetration and reduced cycle times for higher productivity.

- **One push power-up function:** The kick-down switch also functions as a power-up switch in first gear. The first time the kick-down switch is depressed it functions as a kick-down switch and gear speed is reduced. When the machine is in E operation mode and first gear, pressing the kick-down switch a second time changes the operation mode to P allowing increased power for heavy digging operation. The operation mode returns to E when machine gear speed changes or direction changes to reverse.

- **Hold switch:** Auto shift is selected and if the operator turns on this switch when the lever is at the 3rd or 4th gear speed position, the transmission is fixed to that gear speed.

### Electronically Controlled Transmission Lever



#### Easy shifting and directional changes

with Komatsu two-lever electronic shifting. Change direction or shift gears with a touch of the fingers without removing the

shifting hand from the steering wheel. Solid state electronics and conveniently located direction and gear shift controls make this possible. Automatic shifts in ranges two through four keep production high and manual shifting at a minimum.

### Variable Transmission Cut-off System

The operator can continuously adjust the transmission cut-off pressure desired for the left brake pedal using switch located on the right-side control panel. The operator can improve the working performance by setting the cut-off pressure properly depending on working condition.

- High cut-off pressure for digging operations.
- Low cut-off pressure for truck-loading operations.



- 1: Cut-off ON/OFF switch
- 2: Cut-off adjustment switch
- 3: Fan reverse ON/OFF switch
- 4: Boom control
- 5: Bucket control





### Fingertip Work Equipment Control Levers with Large Size Arm Rest

New PPC control levers are used for the work equipment. The operator can easily operate the work equipment with fingertip control, reducing operator fatigue and increasing controllability. The PPC control lever column can be slid



forward or rearward and the large size arm rest can be adjusted up or down to provide the operator with a variety of comfortable operating positions.

### Telescopic/Tilt Steering Column

The operator can tilt and telescope the steering column to provide a comfortable working position.



## Comfortable Operation

### Low-noise Design

Noise at operator's ear noise level : 72 dB(A)

Dynamic noise level (outside): 112 dB(A)

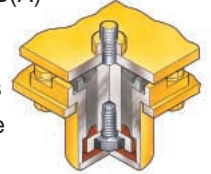

The large cab is mounted with Komatsu's unique ROPS/FOPS viscous mounts. The low-noise engine, hydraulically driven fan, and hydraulic pumps are mounted with rubber cushions, and the cab sealing is improved to provide a quiet, low-vibration, dustproof with pressurizing, and comfortable operating environment. Also, exterior noise is lowest in this class.

### Pillar-less Large Cab



A wide pillar-less flat glass provides excellent front visibility. The wiper arm covers a large area to provide great visibility even on rainy days.

The cab area is the largest in its class providing maximum space for the operator. Increased seat slide adjustment to backward by introducing front mounted air conditioner unit.

### Rear-hinged Full Open Cab Door

The cab door hinges are installed to the rear side of the cab providing a large opening angle for the operator to enter and exit. The steps are designed like a staircase, so that the operator can get on and off the cab easily.

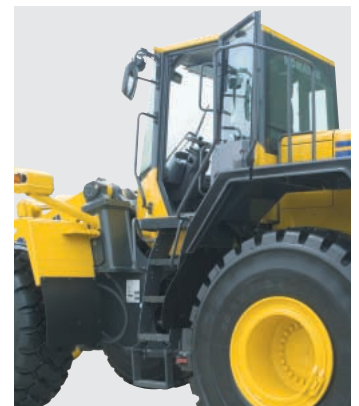

# SPECIFICATIONS



## ENGINE

Model .....Komatsu SAA6D125E-5  
 Type .....Water-cooled, 4-cycle  
 Aspiration .....Turbocharged, aftercooled, cooled EGR  
 Number of cylinders .....6  
 Bore x stroke .....125 mm x 150 mm 4.9" x 5.9"  
 Piston displacement .....11.04 ltr 674 in<sup>3</sup>  
 Governor .....all-speed, electronic  
 Horsepower  
 SAE J1995 .....Gross **204 kW** 273 HP  
 ISO 9249/SAE J1349\* .....Net **203 kW** 272 HP  
 Rated rpm .....2000 rpm  
 Fan drive method for radiator cooling .....Hydraulic  
 Fuel system .....Direct injection  
 Lubrication system:  
 Method .....Gear pump, force-lubrication  
 Filter .....Full-flow type  
 Air cleaner .....Dry type with double elements and  
 dust evacuator, plus dust indicator

\*Net horsepower at the maximum speed of radiator cooling fan is 191 kW 256 HP.

EPA Tier 3 and EU Stage 3A emissions certified.



## TRANSMISSION

Torque converter:  
 Type .....3-element, single-stage, single-phase  
 Transmission:  
 Type .....Full-powershift, countershaft type  
 Travel speed: **km/h** mph  
 Measured with 23.5-25 tires

	1st		2nd		3rd		4th	
Forward	7.0	4.3	12.2	7.6	21.3	13.2	33.7	20.9
Reverse	7.3	4.5	12.6	7.8	21.9	13.6	34.7	21.6

Measured with 26.5-25 tires

	1st		2nd		3rd		4th	
Forward	7.6	4.7	13.1	8.1	22.9	14.2	36.2	22.5
Reverse	7.9	4.9	13.5	8.4	23.6	14.7	37.3	23.2



## AXLES AND FINAL DRIVES

Drive system .....Four-wheel drive  
 Front .....Fixed, semi-floating  
 Rear .....Center-pin support, semi-floating,  
 26° total oscillation  
 Reduction gear .....Spiral bevel gear  
 Differential gear .....Conventional type  
 Final reduction gear .....Planetary gear, single reduction



## BRAKES

Service brakes .....Hydraulically actuated,  
 wet disc brakes actuate on four wheels  
 Parking brake .....Wet disc brake  
 Emergency brake .....Parking brake is commonly used



## STEERING SYSTEM

Type .....Articulated type, full-hydraulic power steering  
 Steering angle .....35° each direction (40° end stop)  
 Minimum turning radius at  
 the center of outside tire .....6630 mm 21'9"



## HYDRAULIC SYSTEM

Steering system:  
 Hydraulic pump .....Piston pump  
 Capacity .....195 ltr/min 51.5 U.S. gal/min at rated rpm  
 Relief valve setting .....24.5 MPa 250 kgf/cm<sup>2</sup> 3,555 psi  
 Hydraulic cylinders:  
 Type .....Double-acting, piston type  
 Number of cylinders .....2  
 Bore x stroke .....90 mm x 441 mm 3.5" x 17.3"

Loader control:  
 Hydraulic pump .....Piston pump  
 Capacity .....260 ltr/min 68.7 U.S. gal/min at rated rpm  
 Relief valve setting .....34.3 MPa 350 kgf/cm<sup>2</sup> 4,980 psi  
 Hydraulic cylinders:  
 Type .....Double-acting, piston type  
 Number of cylinders—bore x stroke:  
 Lift cylinder .....2- 140 mm x 764 mm 5.5" x 30.0"  
 Bucket cylinder .....1- 160 mm x 575 mm 6.3" x 22.6"  
 Control valve .....2-spool type  
 Control positions:  
 Boom .....Raise, hold, lower, and float  
 Bucket .....Tilt-back, hold, and dump  
 Hydraulic cycle time (rated load in bucket)  
 Raise .....5.4 sec  
 Dump .....1.6 sec  
 Lower (Empty) .....3.7 sec



## SERVICE REFILL CAPACITIES

Cooling system .....61 ltr 16.1 U.S. gal  
 Fuel tank .....413 ltr 109.1 U.S. gal  
 Engine .....38 ltr 10.0 U.S. gal  
 Hydraulic system .....173 ltr 45.7 U.S. gal  
 Axle front .....60 ltr 15.9 U.S. gal  
 rear .....56 ltr 14.8 U.S. gal  
 Torque converter and transmission .....65 ltr 17.2 U.S. gal



## BUCKET SELECTION GUIDE

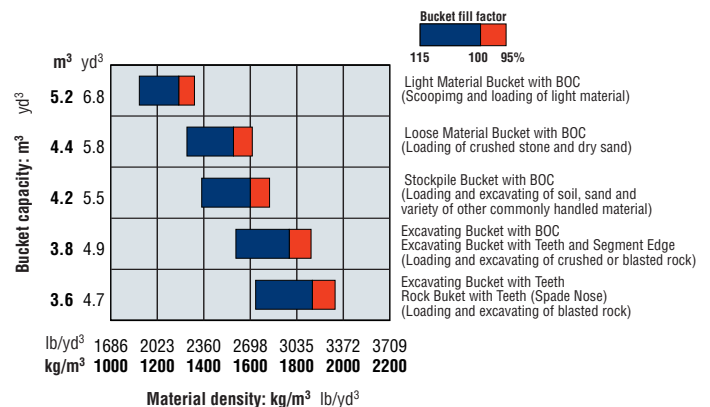



**DIMENSIONS**

Measured with 26.5-25-16PR (L-3) tires

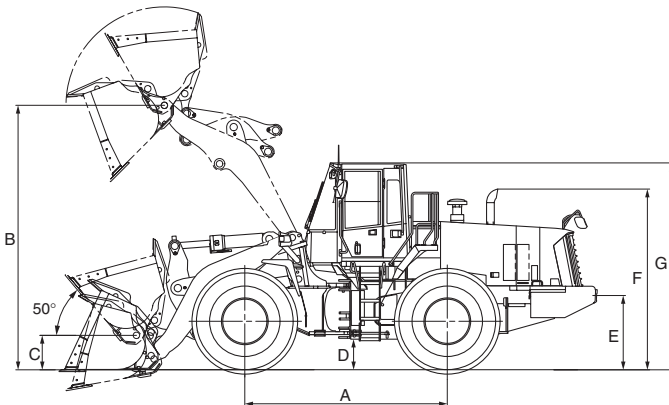

Tread	2300 mm	7'7"
Width over tires	3010 mm	9'11"
A Wheelbase	3450 mm	11'4"
B Hinge pin height, max. height	4360 mm	14'4"
C Hinge pin height, carry position	585 mm	1'11"
D Ground clearance	525 mm	1'9"
E Hitch height	1240 mm	4'1"
F Overall height, top of the stack	3080 mm	10'1"
G Overall height, ROPS cab	3500 mm	11'6"

	General Purpose Buckets					Rock Bucket (Spade nose)	Loose Material Bucket	Light Material Bucket
	Stockpile		Excavating					
	Bolt-on Cutting edges	Teeth	Bolt-on Cutting edges	Teeth and Segments	Teeth			
Bucket capacity: heaped	4.2 m <sup>3</sup>	3.9 m <sup>3</sup>	3.8 m <sup>3</sup>	3.8 m <sup>3</sup>	3.6 m <sup>3</sup>	3.6 m <sup>3</sup>	4.4 m <sup>3</sup>	5.2 m <sup>3</sup>
	5.5 yd <sup>3</sup>	5.1 yd <sup>3</sup>	5.0 yd <sup>3</sup>	5.0 yd <sup>3</sup>	4.7 yd <sup>3</sup>	4.7 yd <sup>3</sup>	5.8 yd <sup>3</sup>	6.8 yd <sup>3</sup>
struck	3.5 m <sup>3</sup>	3.3 m <sup>3</sup>	3.2 m <sup>3</sup>	3.2 m <sup>3</sup>	3.1 m <sup>3</sup>	3.1 m <sup>3</sup>	3.9 m <sup>3</sup>	4.5 m <sup>3</sup>
	4.6 yd <sup>3</sup>	4.3 yd <sup>3</sup>	4.2 yd <sup>3</sup>	4.2 yd <sup>3</sup>	4.1 yd <sup>3</sup>	4.1 yd <sup>3</sup>	5.1 yd <sup>3</sup>	5.9 yd <sup>3</sup>
Bucket width	3170 mm	3190 mm	3170 mm	3190 mm	3190 mm	3170 mm	3170 mm	3170 mm
	10'5"	10'6"	10'5"	10'6"	10'6"	10'5"	10'5"	10'5"
Bucket weight	2050 kg	1970 kg	2150 kg	2200 kg	2070 kg	2165 kg	2110 kg	2185 kg
	4,519 lb	4,343 lb	4,740 lb	4,850 lb	4,564 lb	4,773 lb	4,652 lb	4,817 lb
Dumping clearance, max. height and 45° dump angle*	3185 mm	3060 mm	3235 mm	3110 mm	3110 mm	2975 mm	3055 mm	3035 mm
	10'5"	10'0"	10'7"	10'2"	10'2"	9'9"	10'0"	9'11"
Reach at max. height and 45° dump angle*	1235 mm	1335 mm	1185 mm	1285 mm	1285 mm	1435 mm	1365 mm	1385 mm
	4'1"	4'5"	3'11"	4'3"	4'3"	4'8"	4'6"	4'7"
Reach at 2130 mm (7') clearance and 45° dump angle	1935 mm	1975 mm	1905 mm	1950 mm	1950 mm	2035 mm	2010 mm	2020 mm
	6'4"	6'6"	6'3"	6'5"	6'5"	6'8"	6'7"	6'8"
Reach with arm horizontal and bucket level	2755 mm	2910 mm	2685 mm	2840 mm	2840 mm	3040 mm	2940 mm	2965 mm
	9'0"	9'7"	8'10"	9'4"	9'4"	10'0"	9'8"	9'9"
Operating height (fully raised)	5960 mm	5960 mm	5875 mm	5875 mm	5875 mm	5875 mm	5960 mm	6185 mm
	19'7"	19'7"	19'3"	19'3"	19'3"	19'3"	19'7"	20'4"
Overall length	8825 mm	8980 mm	8755 mm	8910 mm	8910 mm	9210 mm	9010 mm	9035 mm
	28'11"	29'6"	28'9"	29'3"	29'3"	29'11"	29'7"	29'8"
Loader clearance circle (35°) (bucket at carry, outside corner of bucket)	15280 mm	15380 mm	15240 mm	15340 mm	15340 mm	15280 mm	15370 mm	15380 mm
	50'2"	50'6"	50'0"	50'4"	50'4"	50'2"	50'5"	50'6"
Digging depth: 0°	80 mm	100 mm	80 mm	100 mm	100 mm	85 mm	80 mm	80 mm
	3.1"	3.9"	3.1"	3.9"	3.9"	3.3"	3.1"	3.1"
10°	315 mm	360 mm	305 mm	350 mm	350 mm	370 mm	345 mm	350 mm
	1'0"	1'2"	1'0"	1'2"	1'2"	1'3"	1'2"	1'2"
Static tipping load: straight	18295 kg	18370 kg	18205 kg	18160 kg	18275 kg	18190 kg	18240 kg	18175 kg
	40,330 lb	40,500 lb	40,130 lb	40,040 lb	40,290 lb	40,100 lb	40,210 lb	40,070 lb
40° full turn	15720 kg	15795 kg	15630 kg	15585 kg	15705 kg	15615 kg	15665 kg	15600 kg
	34,660 lb	34,820 lb	34,460 lb	34,360 lb	34,620 lb	34,420 lb	34,530 lb	34,390 lb
Breakout force	192 kN	207 kN	203 kN	209 kN	220 kN	190 kN	168 kN	165 kN
	19600 kgf	21120 kgf	20710 kgf	21330 kgf	22450 kgf	19390 kgf	17140 kgf	16840 kgf
	43,160 lb	46,560 lb	45,660 lb	47,020 lb	49,490 lb	42,750 lb	37,790 lb	37,130 lb
Operating weight	22960 kg	22880 kg	23060 kg	23110 kg	22980 kg	23075 kg	23020 kg	23095 kg
	50,620 lb	50,440 lb	50,840 lb	50,950 lb	50,660 lb	50,870 lb	50,750 lb	50,910 lb

\* At the end of tooth or B.O.C.

All dimensions, weights, and performance values based on SAE J732c and J742b standards.

Static tipping load and operating weight shown include lubricant, coolant, full fuel tank, ROPS cab, and operator. Machine stability and operating weight affected by counterweight, tire size, and other attachments.

Apply the following weight changes to operating weight and static tipping load.



## WEIGHT CHANGES

Tires or attachments	Operating weight		Tipping load straight		Tipping load full turn		Width over tires		Ground clearance		Change in vertical dimensions	
	kg	lb	kg	lb	kg	lb	mm	ft in	mm	ft in	mm	ft in
23.5-25-20PR(L-3)	-305	-672	-240	-529	-210	-463	2920	9'7"	460	1'6"	-65	-3"
23.5-25-20PR(L-2)	-615	-1,355	-480	-1,058	-420	-926	2920	9'7"	460	1'6"	-65	-3"
26.5-25-16PR(L-3)	0	0	0	0	0	0	3010	9'11"	525	1'9"	0	0
26.5-25-20PR(L-4)	+425	+937	+330	+728	+290	+639	3010	9'11"	525	1'9"	0	0
Install additional counterweight	+400	+880	+1070	+2,358	+930	+2,050						



## STANDARD EQUIPMENT

- 2-spool valve for boom and bucket controls
- Alternator, 50 A
- Auto shift transmission with mode select system
- Back-up alarm
- Back-up lamp
- Batteries, **136 Ah/12 V** x 2
- Counterweight
- Directional signal
- Engine, Komatsu SAA6D125E-5 diesel
- Engine shut-off system, electric
- Hard water area arrangement (corrosion resister)
- Hydraulic-driven fan with reverse rotation
- Lift cylinders and bucket cylinder
- Main monitor panel with EMMS (Equipment Management Monitoring System)
- PPC fingertip control, two levers
- Radiator mask, lattice type
- Rearview mirror for cab
- Rear window washer and wiper
- ROPS/FOPS cab
- Seat belt
- Seat, suspension type with reclining
- Service brakes, wet disc type
- Starting motor, **7.5 kW/24 V**
- Steering wheel, tiltable, telescopic
- Sun visor
- Tires (26.5-25-16PR tubeless) and rims
- Transmission, 4 forward and 4 reverse



## OPTIONAL EQUIPMENT

- 12V converter
- 3-spool valve
- Additional counterweight
- Air conditioner
- AM/FM radio
- AM/FM stereo radio cassette
- Batteries, **140 Ah/12V** x 2
- Bucket teeth (bolt-on type)
- Bucket teeth (tip type)
- Cutting edge (bolt-on type)
- ECSS (Electronically Controlled Suspension System)
- Emergency steering (SAE)
- Engine pre-cleaner with extension
- Fire extinguisher
- Floor mat
- Front fender
- High lift boom
- Joystick steering
- Limited slip differential (F&R)
- Load meter, new type
- Lock-up clutch torque converter
- Ordinary spare parts
- Power train guard
- Seat, air suspension with automatic weight adjustment
- Segment edges
- Tool kit
- Vandalism protection kit

www.Komatsu.com

Printed in Japan 201306 IP.SIN

# KOMATSU®

CEN00133-05

Materials and specifications are subject to change without notice  
**KOMATSU** is a trademark of Komatsu Ltd. Japan