

**WACKER**

CREATING TOMORROW'S SOLUTIONS

HEALTHCARE | MEDICAL TECHNOLOGY

# SILICONES FOR MEDICAL TECHNOLOGY

SILPURAN®

ELASTOSIL®

# HEALTH. CARE. WACKER.



We care. And that's why we keep researching and developing medical solutions that improve quality of life. In applications such as medical devices, orthotics, prosthetics and medical silicone adhesives, you will feel the difference with our innovative silicones. Our experienced WACKER team knows how to find the right solution to the challenge of your specific product.

# WACKER SILICONE RUBBER COMPOUNDS – ANSWERS TO THE MEDICAL QUESTIONS OF TOMORROW

Regardless of the challenges the future holds, SILPURAN® and ELASTOSIL® offer you future-proof solutions that satisfy the highest standards.

The average age of the population is increasing steadily. At the same time, more and more people are gaining access to modern healthcare, resulting in increasingly strict legal requirements for medical products and services. As a result, the healthcare industry faces ever-increasing demands with regard to the safety and efficiency of its solutions. WACKER has responded to this development with silicone products from its SILPURAN® and ELASTOSIL® lines: future-proof silicone elastomers for the most exacting standards.

As a global market leader for silicone production, WACKER's strength lies both in its unique expertise and pio-

neering research, and in its integrated raw-materials system. That means customers can place their confidence in future-proof solutions that meet the highest German quality standards.

Much more than just two products: SILPURAN® and ELASTOSIL® always stand for the best service available, ensuring your success. Our teams of experts are always at the ready to help you exploit the virtually unlimited flexibility and innovative strength of these products so that they best meet your needs. The resulting customized solutions will help secure lasting success for your business.

SILPURAN® and ELASTOSIL® are available as solid or liquid rubber compounds (HTV or LSR, respectively) and as room-temperature-curing products (RTV-1 and RTV-2).

## Interesting Facts About Silicones

Silicones are modern synthetic materials, whose versatile performance is due to their chemical structure and the many different ways they can be modified.

Thanks to the high energy of the Si-O bond, silicones do an excellent job of resisting the elements. Silicones stand for chemical resistance, thermal stability and outstanding mechanical properties.

- The term “silicone” was coined by F. S. Kipping (1863-1949)
- Silicones consist of a polymer backbone built of alternating silicon and oxygen atoms

- In nature, silicon occurs exclusively in the form of silicon dioxide and silicates
- Silicon is the second most abundant element in the earth's crust (26 percent by weight)
- The energy of a Si-O bond is significantly greater than that of a C-C bond
- The thermal and oxidative stability of silicones is higher than that of most organic plastics and rubber
- Silicones are highly resistant to UV,  $\beta$  and  $\gamma$  radiation

# AS VERSATILE AS MODERN MEDICINE



Their special property profile makes ELASTOSIL® and SILPURAN® silicone elastomers ideal for medical applications. Just three of the many reasons for using these pure materials are that they can be sterilized and offer excellent chemical and physical resistance with no need for additional stabilizers.

Extrudable solid silicone rubber compounds are extremely tear resistant, highly elastic and remarkably resilient at the same time. They are used in numerous pharmaceutical and medical technology tubing applications, such as drainage, peristalsis, breathing and feeding tubes, urinary catheters and tubes for fluid transfer.

Suitable for use in injection and compression molding, SILPURAN® and ELASTOSIL® solid silicone rubber compounds have excellent mechanical

properties, are very durable, serve as good elastic sealing materials and are soft and pleasing to the touch.

Applications range from seals, valves, septa, filters and membranes (such as those in syringe seals or membranes for needle-free injection systems), to respirators and respiratory bellows, handles for equipment and instruments or mats for sterilization trays.

ELASTOSIL® and SILPURAN® liquid silicone rubber enable the economical production of injection molded parts in large scale. Such parts are e.g. used as seals, bellows or membranes and in needle-free valves.

The high level of transparency means they do not restrict the coloring possibilities for your products in any way.

# ELASTOSIL® AND SILPURAN® FOR MEDICAL TECHNOLOGY

## Medically Relevant Properties

The whole SILPURAN® product line as well as many ELSTOSIL® products offer a compelling property profile to meet medical-technology needs:

- Available in a broad range of hardnesses (Shore A)
- Excellent heat resistance as well as chemical and physical resistance with no additional stabilizers
- Highly transparent and good for pigmenting in a broad range of color shades
- Good resistance to UV radiation and X-rays
- Certified biocompatibility (USP<88> class VI and selected tests of ISO 10993)
- Easy to sterilize according to various methods

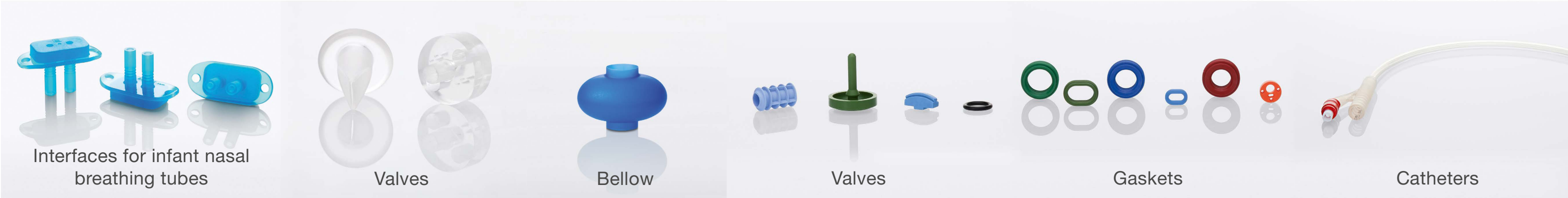

## Resistance in Standard Sterilization Procedures

All potential hazards must be ruled out for medical products, which is why manufacturers implement various sterilization procedures based on heat (dry heat/steam), chemical substances (ethylene oxide) or radiation ( $\gamma$ ,  $\beta$  radiation). Single-use articles are usually sterilized in their packaging using  $\gamma$ / $\beta$  radiation, or ethylene oxide. Medical products intended for repeated use in settings such as hospitals are generally steam-sterilized.

Ideally, product properties should not be influenced by these procedures.

Mechanical properties are not influenced by ethylene-oxide sterilization, see Fig. 1. Very slight changes in mechanical properties occur during steam sterilization at 134 °C and up to 500 cycles (Fig. 2).

The use of ionizing radiation may result in changes to the polymer network.

Series of tests have shown that sterilization procedures using  $\gamma$ / $\beta$  radiation make soft materials (5 to 50 shore A) moderately more brittle and influence other mechanical properties as well. Only minor changes occur with harder materials (Fig. 3). However, deterioration of mechanical properties is not critical for most applications: application specifications are usually not compromised and the functionality of the end product remains intact.

## Durability of SILPURAN® When Subjected to Various Sterilization Procedures

**Fig. 1: Sterilization of SILPURAN® 6000/60 using ethylene oxide (ETO)\***

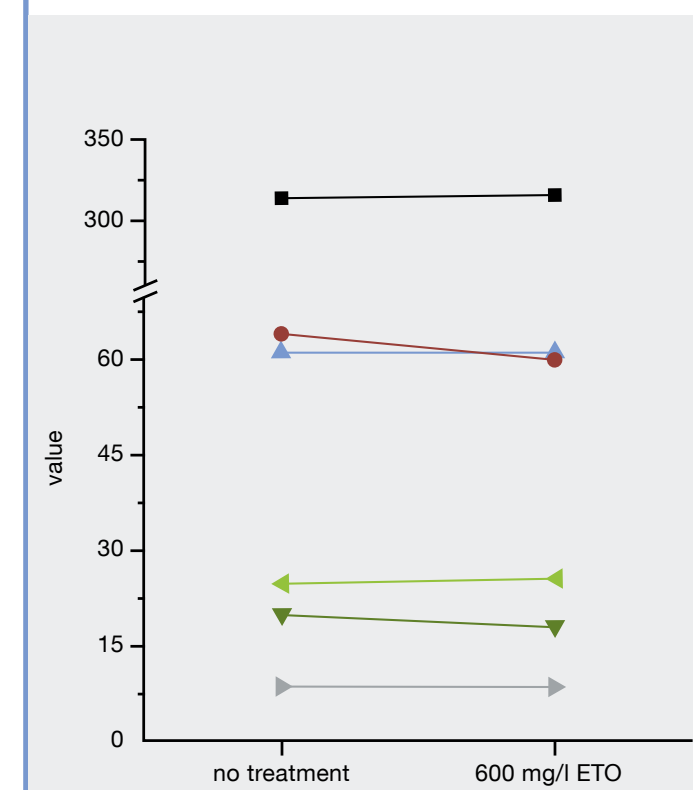

\* according to DIN EN ISO 11135: 1h, 54 °C, 600 mg/L ETO

**Fig. 2: Sterilization of SILPURAN® 6000/60 using steam\*\***

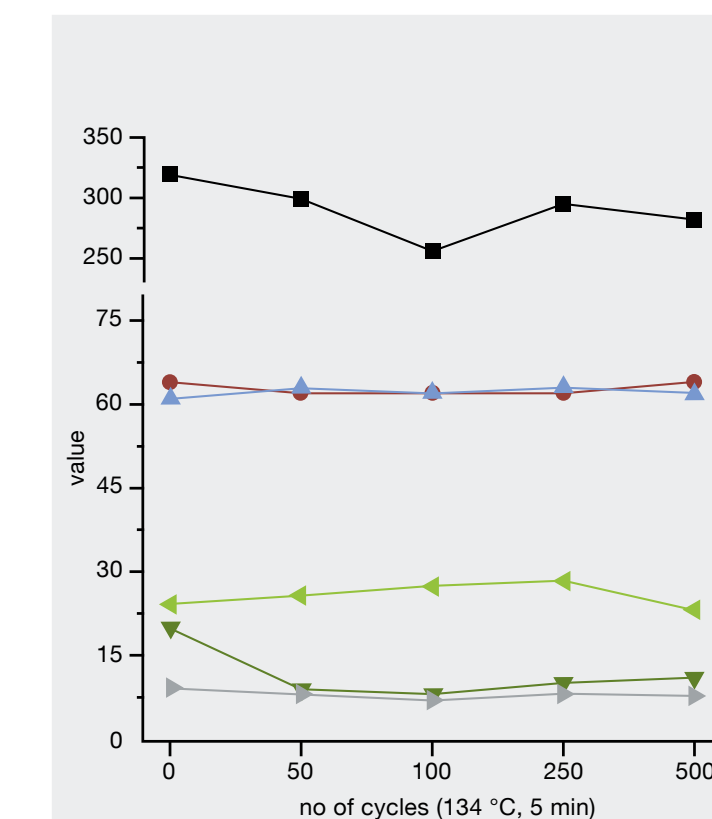

\*\* according to DIN EN ISO 17665 – aging test specified in DIN EN 868-8

**Fig. 3: Sterilization of SILPURAN® 6000/60 using  $\gamma$  radiation\*\*\***

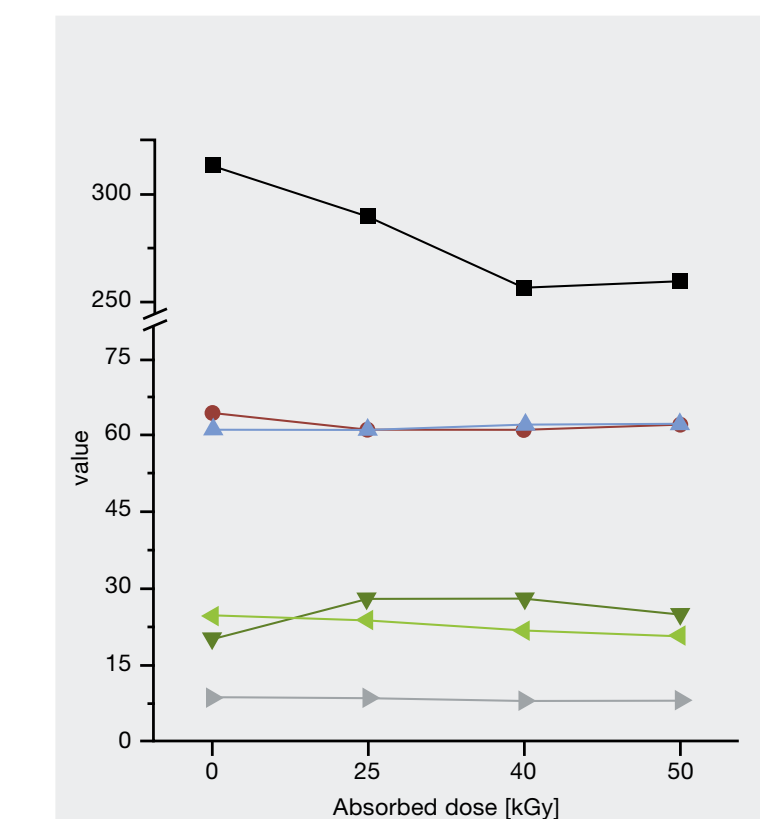

\*\*\* according to DIN EN ISO 11137-2, 2007

- Elongation at break [%]; DIN 53504 S1
- Rebound resilience [%]; DIN 53512
- ▲ Hardness Shore A; DIN 53505
- ▼ Compression set [%] (22 h/175 °C); DIN ISO 815 B
- ◀ Tear strength [N/mm]; ASTM D 624 B
- ▶ Tensile strength [N/mm<sup>2</sup>]; DIN 53504-S1

# SILPURAN® AND ELASTOSIL® FOR A VARIETY OF APPLICATIONS



Duckbill valves

Tube extrusion

Highly transparent molded parts

SILPURAN® silicone elastomers from WACKER are ideal for use in the complex and highly sensitive field of medical technology.

Extrudable SILPURAN®/ELASTOSIL® solid silicone rubber grades are used in numerous tubes in the pharmaceutical and medical industries, such as drainage, peristalsis, breathing and feeding

tubes, urinary catheters and tubes for fluid transfer. SILPURAN®/ELASTOSIL® liquid and solid silicone rubber products are injection or compression molded to produce seals, valves, septa, filters and membranes.

Other applications include respirators, respiratory bellows, instrument handles and mats for sterilization trays.

# SILPURAN® AND ELASTOSIL®

## FOR A VARIETY OF APPLICATIONS

Product Name	Properties	Typical Applications
SILPURAN® 4200	1-part condensation-curing silicone adhesive (tin-free)	Bonding cured silicone parts, highly elastic bonding between silicone and textiles
SILPURAN® 6000	2-part liquid silicone rubber	Seals, valves, connectors, bellows
SILPURAN® 6400	2-part liquid silicone rubber, high tear resistance	Seals, valves, bellows, masks
SILPURAN® 6600	2-part liquid silicone rubber, low coefficient of dynamic friction	Seals, valves
SILPURAN® 6610	2-part liquid silicone rubber, non-healing	Slotted membranes, needle-free valves
SILPURAN® 6700	2-part liquid silicone rubber, self-adhesive	Seals, valves, membranes, bellows
SILPURAN® 6740	2-part liquid silicone rubber, self-adhesive, high tear resistance	Seals, valves, membranes, masks
SILPURAN® 6760	2-part liquid silicone rubber, self-adhesive, low coefficient of dynamic friction	Seals, valves
SILPURAN® 8020	2-part, platinum-curing solid silicone rubber for molding	Molding, e.g. highly transparent molded parts
SILPURAN® 8030	2-part, platinum-curing solid silicone rubber for extrusion	Extrusion, e.g. highly transparent catheters and tubes
SILPURAN® 8060	Peroxide-curing solid silicone rubber for molding and extrusion	Extrusion and molding, e.g. seals, tubing
SILPURAN® AUX 8250 RO SILPURAN® AUX 8251 RO	Barium sulfate batch for HTV compounds	X-ray opaque tubing
SILPURAN® 8461	Peroxide-curing solid silicone rubber for extrusion, high tear resistance	Extrusion, e.g. tear-resistant tubing
SILPURAN® 8630	2-part, platinum-curing solid silicone rubber for extrusion, low coefficient of dynamic friction	Extrusion, e.g. catheters and tubing with low coefficients of dynamic friction

Further products and specific product characteristics can be found in the tables below and in our technical data sheets.













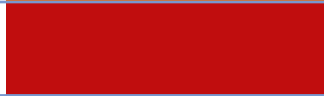

# ADD COLOR TO YOUR MEDICAL TECHNOLOGY PRODUCTS

Add color to your applications with our color master batches for the medical technology market. Select tests described in ISO 10993 and USP Class VI were used for verifying biocompatibility of a large number of base colors. You can cover a great deal of the color space by using or blending these colors.

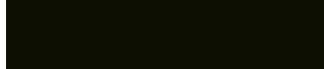

# ADD COLOR TO YOUR MEDICAL TECHNOLOGY PRODUCTS

Biocompatible Pigment Pastes for Liquid Silicone Rubber ELASTOSIL® FL Color Pastes <sup>(1)</sup>								
Color	Name	Similar RAL <sup>(2)</sup>	Affix	BfR <sup>(4),(6)</sup>	FDA <sup>(3),(5),(6)</sup>	ISO 10993 <sup>(7)</sup>	USP Class VI <sup>(8)</sup>	Color
EL FL	Yellow	RAL 1016		x	x <sup>(9)</sup>	x	x	
EL FL	Yellow	RAL 1026	F	x	x <sup>(10)</sup>	x	x	
EL FL	Orange	RAL 2004	F	x	x <sup>(9)</sup>	x	x	
EL FL	Red	RAL 3000	F	x	x <sup>(10)</sup>	x	x	
EL FL	Red	RAL 3013		x	x		x	
EL FL	Red	RAL 3020		x	x <sup>(9)</sup>	x	x	
EL FL	Red-violet	RAL 4002		x	x <sup>(11)</sup>	x	x	
EL FL	Ultramarine blue	RAL 5002		x	x	x	x	
EL FL	Blue	RAL 5010		x	x	x	x	
EL FL	Blue	RAL 5022		x	x	x	x	
EL FL	Helio-green	RAL 6004		x	x	x	x	
EL FL	Green	RAL 6010		x	x	x	x	
EL FL	White	RAL 9010		x	x	x	x	
EL FL	Black	RAL 9005	F	x	x	x	x	
EL FL	Deep black	RAL 9011		x	x	x	x	

- (1) For questions regarding the biocompatibility of our PT pigment pastes for solid silicone rubber, please contact our technical service department.
- (2) The RAL numbers in the table are only a guide.
- (3) An important aspect of meeting the requirements stipulated in the Code of Federal Regulations (CFR), Title 21, Sec. 177.2600 “Rubber articles intended for repeated use” is precise compliance with concentration limits and limitations on the conditions of use in conjunction with Sec. 178.3297 “Colorants for Polymers.” Information on how these regulations pertain to individual pigment pastes can be found in our product compliance sheets or in separate food contact statements for the pigment paste in question. Our technical service personnel will be happy to assist you.
- (4) BfR recommendation “XV. Silicone“ (BfR = Bundesinstitut für Risikobewertung) (German Institute for Risk Assessment)
- (5) FDA 21 CFR Sec. 177.2600 “Rubber articles intended for repeated use (FDA = Food and Drug Administration)
- (6) Conformance with BfR and FDA requirements may in certain circumstances depend on compliance with the specified concentration limits. We will be glad to assist you.
- (7) Cytotoxicity, pyrogenicity, sensitizing LLNA, further tests on request
- (8) Systemic/intracutaneous toxicity, implantation test (5 days)
- (9) Please observe the conditions of use (B-H) defined for temperature and duration in table 2 under Title 21, CFR Sec. 176.170.
- (10) Please observe the conditions of use (C-H) defined for temperature and duration in table 2 under Title 21, CFR Sec. 176.170.
- (11) Please observe the conditions of use (A-H) defined for temperature and duration in table 2 under Title 21, CFR Sec. 176.170.

# MANUFACTURING PROCESSES FOR HTV / LSR RUBBER

SILPURAN® and ELASTOSIL® HTV/LSR\* can be processed using various methods, such as extrusion, coextrusion, compression molding, transfer molding or injection molding. The two main processes are described as follows.

Schematic diagram of an extruder with crosshead die

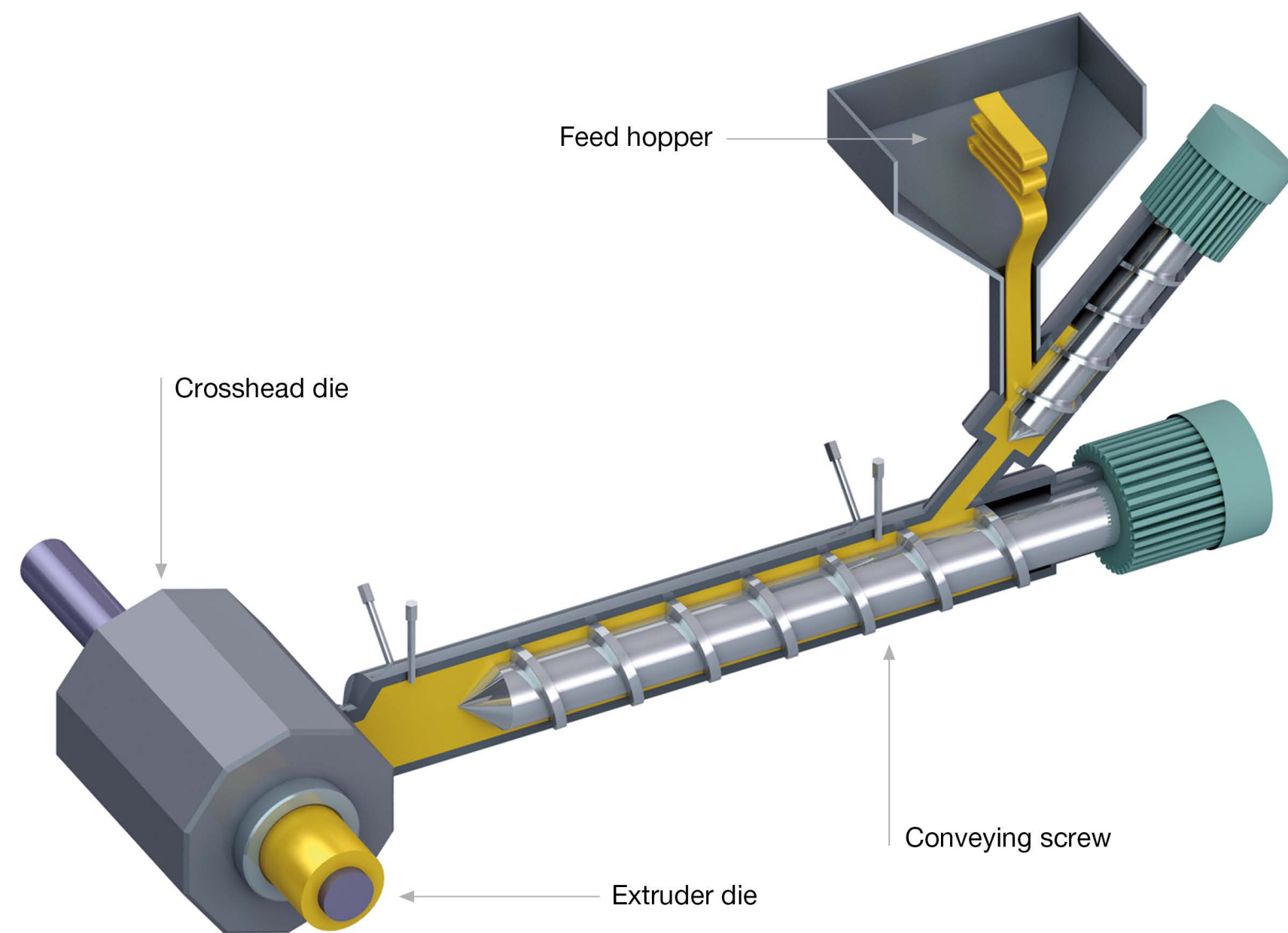

## 1. Extrusion

Extrusion is a continuous manufacturing process in which silicone rubber is forced through a die and then vulcanized. The die is responsible for giving the extruded material its shape. The necessary pressure is produced via a conveying screw, in which the material is homogenized, compacted and degassed. One example of products made this way is tubing for the medical and pharmaceutical industries.

\*HTV (= high-temperature-vulcanizing solid silicone rubber)/LSR (= liquid silicone rubber)

# MANUFACTURING PROCESSES FOR HTV / LSR RUBBER

Schematic diagram of injection molding with metering unit and mixing station

## 2. Injection Molding

Injection molding is currently the most popular and efficient method for processing large quantities of silicones meeting strict demands for consistently high product quality. Liquid and solid grades of SILPURAN®/ ELASTOSIL® silicone rubber can each be used in the production of seals, membranes and valves – the process is fully automatic.

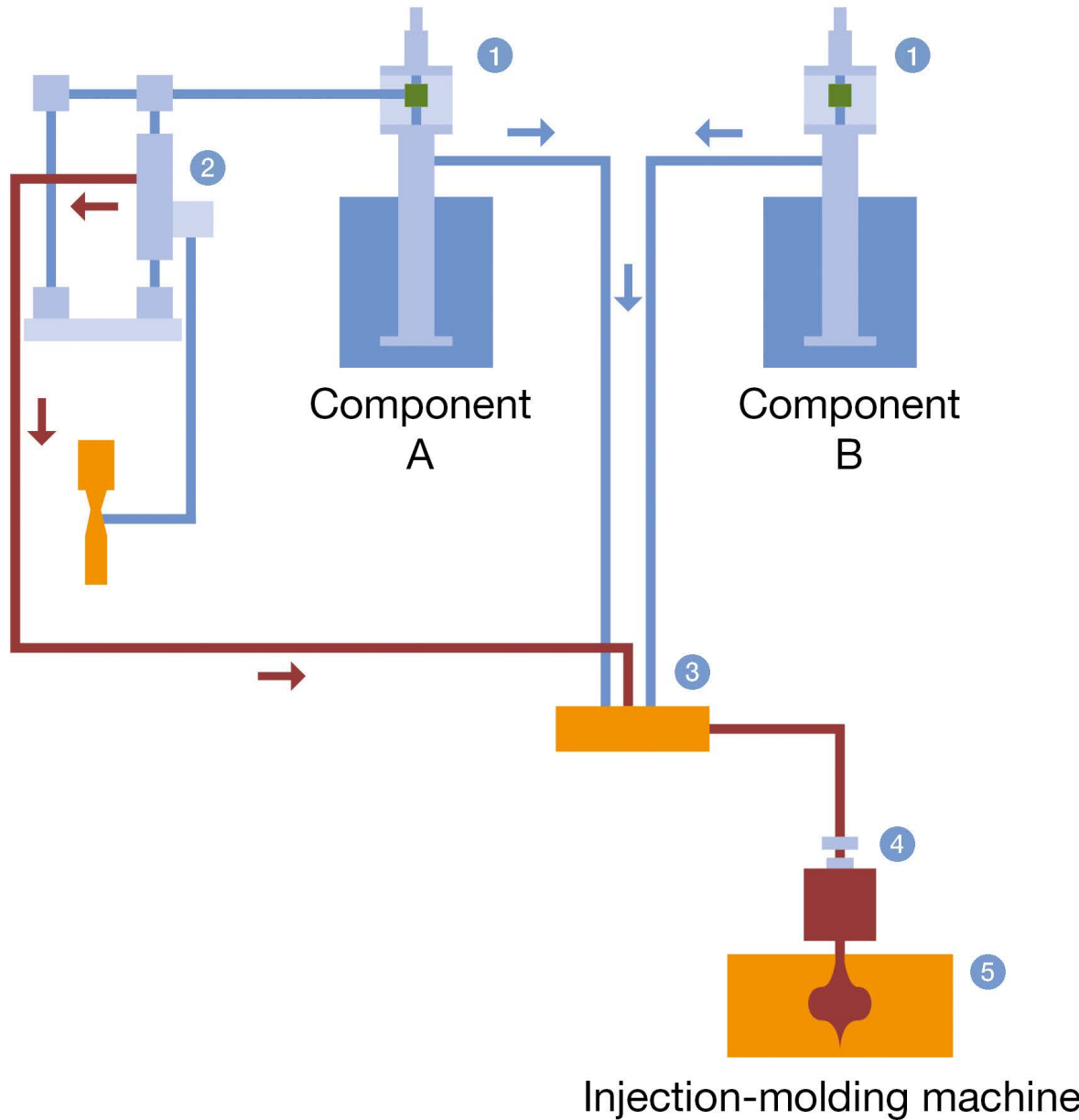

- ① Metering unit for the A and B components of the liquid silicone rubber
- ② Metering unit for color / additives
- ③ Mixing station
- ④ Metering cylinder
- ⑤ Heated injection mold with injection-molded part

# A SAFE BET FOR FUTURE SUCCESS

## Progress Rooted in Tradition

As early as 1947, WACKER became the first European company to venture into research in the field of silicones. This was the beginning of a success story that established WACKER as a European pioneer in silicone chemistry, and made it into one of the world's leading silicone manufacturers.

## Future-Proof Quality Right From the Start

WACKER's internal raw materials network ensures the future availability of raw materials, guaranteeing the finest quality and maximizing traceability back to the original source. This provides the ideal basis for further processing in accordance with stringent quality criteria.

## Investing in Pioneering Solutions

Investment in research and development far exceeding the global

chemical-industry average paves the way for cutting-edge innovations, ensuring that SILPURAN® and ELASTOSIL® always fulfill the ever-increasing demands of industry.

## Keeping Ahead of Challenges with Confidence

SILPURAN® as well as many grades of the ELASTOSIL® family are tested for biocompatibility and comply with current standards for modern medical technology. (See info box on the right: "Certified Safe")

## Safety Features for the Challenges Facing You in the Future

In addition to their extraordinary purity, compelling properties of SILPURAN® and ELASTOSIL® also include excellent tolerability and utter reliability. These silicones are steam-sterilizable, resistant to heat and radiation, highly flexible and available

across a very broad range of Shore hardness values. Moreover, silicones do not contain any phthalates, other organic plasticizers, latex, plant proteins, organic stabilizers or animal-based materials.

## Reliable Application Characteristics

- Biocompatibility
- Biodurability: low surface tension, thermal stability, chemical stability, excellent mechanical properties
- Good resistance to a large number of solvents and chemicals
- Sterilizable for single and repeated use (sterilizable with steam, ethylene oxide, electron beams and  $\gamma$ -rays)
- Good weathering, UV and aging resistance
- Highly transparent
- Silicones do not support microbial growth

Please note that the WACKER SILICONES HEALTH CARE POLICY limits the use of WACKER silicones for certain medical applications. More information on this topic can be found on our website [www.wacker.com](http://www.wacker.com).

## Certified Safe

- The SILPURAN® product line as well as many grades of the ELASTOSIL® family have been tested for biocompatibility according to selected ISO 10993 and USP Class VI tests
- Numerous SILPURAN® and ELASTOSIL® LSR/HTV grades comply with the requirements of the BfR (German Institute for Risk Assessment, XV Silicones, Section III, Silicone Elastomers) and the FDA CFR 21 §. 177.2600 "Rubber articles intended for repeated use", making them suitable for food contact

# SILPURAN® HIGH PURITY TO MEET THE HEALTHCARE NEEDS



WACKER's SILPURAN® product line was developed to meet the needs of the healthcare industry<sup>1</sup>.

SILPURAN® products contain defined ingredients only and do not contain organic plasticizers.

SILPURAN® products provide biocompatibility based on certified compliance according to selected ISO 10993 and USP Class VI tests.

All products are produced according to the WACKER CLEAN OPERATIONS standard to meet the quality and cleanliness needs of healthcare applications.

## Key features of WACKER CLEAN OPERATIONS

- Selected mixers, 50 µm filtration
- Air-controlled filling environment
- Trained, qualified employees
- Documentation and tracking

The WACKER CLEAN OPERATIONS standard has been implemented at several WACKER production sites.

<sup>1</sup> Limited to the WACKER healthcare policy

# SILPURAN® / ELASTOSIL® – LIQUID SILICONE RUBBER

Product	Properties	Product Description	Typical Applications	Hard-ness Shore A	Tensile Strength (DIN 53 504-S1) [N/mm <sup>2</sup> ]	Elongation at Break (DIN 53 504-S1) [%]	Tear Resistance (ASTM D 624 B) [N/mm]	USP Class VI <sup>(1)</sup>	ISO 10993 <sup>(2)</sup>	BfR <sup>(3)</sup>	FDA <sup>(4)</sup>
SILPURAN® 6000	High mechanical strength	<ul style="list-style-type: none"> <li>Readily pigmentable LSR with short curing times (1:1 A/B system)</li> <li>Produced in accordance with the WACKER CLEAN OPERATIONS Standard</li> </ul>	<ul style="list-style-type: none"> <li>Medical/pharmaceutical applications</li> <li>Seals, connectors, valves, bellows, etc.</li> </ul>	05	2.5	700	6	x	x	x	
				10	4.2	740	12	x	x	x	
				20	8.0	850	21	x	x	x	x
				30	8.6	650	25	x	x	x	x
				40	9.6	600	29	x	x	x	x
				50	10.0	480	30	x	x	x	x
				60	10.0	350	27	x	x	x	x
SILPURAN® 6400	High tear resistance	<ul style="list-style-type: none"> <li>Readily pigmentable LSR with short curing times (1:1 A/B system)</li> <li>Produced in accordance with the WACKER CLEAN OPERATIONS Standard</li> </ul>	<ul style="list-style-type: none"> <li>Medical/pharmaceutical applications</li> <li>For molded parts subjected to significant mechanical stress (masks, seals, bellows, etc.)</li> </ul>	40	9.2	630	35	x	x	x	x
				50	9.1	450	47	x	x	x	x
				60	9.5	430	51	x	x	x	x
SILPURAN® 6600	Low coefficient of friction	<ul style="list-style-type: none"> <li>Readily pigmentable LSR with short curing times (1:1 A/B system)</li> <li>Produced in accordance with the WACKER CLEAN OPERATIONS Standard</li> </ul>	<ul style="list-style-type: none"> <li>Medical/pharmaceutical applications</li> <li>Low coefficient of dynamic friction for easy assembly (seals, valves, etc) and easy function</li> </ul>	40	9.4	550	35	x	x	x	x
				50	8.9	440	31	x	x	x	x
				60	9.0	310	26	x	x	x	x

These figures are only intended as a guide and should not be used in preparing specifications. Please contact us regarding our products' conformity to the European Pharmacopoeia, section 3.1.9 "Silicone elastomers for closures and tubing" Please contact your technical service manager to see whether ELASTOSIL® products are suitable for your projects and applications.

(1) Systemic/intracutaneous toxicity, implantation test (5 days)

(2) Cytotoxicity, sensitization LLNA, pyrogenicity, additional tests upon request

(3) BfR recommendation "XV. Silicone" (BfR = Bundesinstitut für Risikobewertung) (German Institute for Risk Assessment)

(4) FDA 21 CFR § 177.2600 "Rubber articles intended for repeated use" (FDA = Food and Drug Administration)

# SILPURAN® / ELASTOSIL® – LIQUID SILICONE RUBBER

Product	Properties	Product Description	Typical Applications	Hardness Shore A	Tensile Strength (DIN 53 504-S1) [N/mm <sup>2</sup> ]	Elongation at Break (DIN 53 504-S1) [%]	Tear Resistance (ASTM D 624 B) [N/mm]	USP Class VI <sup>(1)</sup>	ISO 10993 <sup>(2)</sup>	BfR <sup>(3)</sup>	FDA <sup>(4)</sup>
SILPURAN® 6610	Reduced healing	<ul style="list-style-type: none"> <li>LSR (white) with short curing times (1:1 A/B system)</li> <li>Produced in accordance with the WACKER CLEAN OPERATIONS Standard</li> </ul>	<ul style="list-style-type: none"> <li>Needle-free valves, slotted membranes</li> <li>Significantly reduced tendency toward free-radical-induced healing of slits during <math>\gamma</math> sterilization or electron radiation (<math>\leq 75</math> kGy)</li> </ul>	40	7.2	550	32	x	x	x	x
				50	8.0	440	31	x	x	x	x
				60	7.0	310	26	x	x	x	x
SILPURAN® 6700	Primer-free self-adhesion on many substrates	<ul style="list-style-type: none"> <li>Readily pigmentable LSR with short curing times (1:1 A/B system)</li> <li>Produced in accordance with the WACKER CLEAN OPERATIONS Standard</li> </ul>	<ul style="list-style-type: none"> <li>Medical/pharmaceutical applications</li> <li>Self-adhesion for 2-part injection molding</li> </ul>	40	8.5	640	23	x	x	x	x
				50	8.5	590	24	x	x	x	x
				60	8.2	490	26	x	x	x	x
SILPURAN® 6740	Primer-free self-adhesion on many sub- strates, high tear resistance	<ul style="list-style-type: none"> <li>Readily pigmentable LSR with short curing times (1:1 A/B system)</li> <li>Produced in accordance with the WACKER CLEAN OPERATIONS Standard</li> </ul>	<ul style="list-style-type: none"> <li>Medical/pharmaceutical applications</li> <li>Self-adhesion for 2-part injection molding</li> </ul>	40	9.2	710	25	x	x	x	x

These figures are only intended as a guide and should not be used in preparing specifications. Please contact us regarding our products' conformity to the European Pharmacopoeia, section 3.1.9 "Silicone elastomers for closures and tubing" Please contact your technical service manager to see whether ELASTOSIL® products are suitable for your projects and applications.

(1) Systemic/intracutaneous toxicity, implantation test (5 days)

(2) Cytotoxicity, sensitization LLNA, pyrogenicity, additional tests upon request

(3) BfR recommendation "XV. Silicone" (BfR = Bundesinstitut für Risikobewertung) (German Institute for Risk Assessment)

(4) FDA 21 CFR § 177.2600 "Rubber articles intended for repeated use" (FDA = Food and Drug Administration)



# SILPURAN® / ELASTOSIL® – LIQUID SILICONE RUBBER

Product	Properties	Product Description	Typical Applications	Hardness Shore A	Tensile Strength (DIN 53 504-S1) [N/mm <sup>2</sup> ]	Elongation at Break (DIN 53 504-S1) [%]	Tear Resistance (ASTM D 624 B) [N/mm]	USP Class VI <sup>(1)</sup>	ISO 10993 <sup>(2)</sup>	BfR <sup>(3)</sup>	FDA <sup>(4)</sup>
SILPURAN® 6760	Primer-free self-adhesion many of sub- strates, low coefficient of friction	<ul style="list-style-type: none"> <li>Readily pigmentable LSR with short curing times (1:1 A/B system)</li> <li>Produced in accordance with the WACKER CLEAN OPERATIONS Standard</li> </ul>	<ul style="list-style-type: none"> <li>Medical/pharmaceutical applications</li> <li>Self-adhesion for 2-part injection molding</li> </ul>	50	8.4	600	27	x	x	x	x
ELASTOSIL® LR 34004	X-ray opaque	<ul style="list-style-type: none"> <li>LSR (white) (1:1 A/B system)</li> <li>X-ray opaque</li> </ul>	<ul style="list-style-type: none"> <li>X-ray opaque injection molded parts</li> </ul>	50	7.8	450	26	x	x	x	x
ELASTOSIL® LR 5040	Low vola- tiles content, even without post-curing	<ul style="list-style-type: none"> <li>Readily pigmentable LSR with short curing times (1:1 A/B system)</li> <li>Low volatiles content and good mechanical properties, even without post-curing</li> </ul>	<ul style="list-style-type: none"> <li>Cost-effective, large-scale production of injection-molded parts</li> </ul>	20	7.9	890	33	x	x	x	x
				30	9.2	760	32	x	x	x	x
				40	9.0	580	38	x	x	x	x
				45	9.0	580	38	x	x	x	x
				50	9.5	490	42	x	x	x	x
				60	9.0	380	50	x	x	x	x
				70	9.5	370	36	x	x	x	x

These figures are only intended as a guide and should not be used in preparing specifications. Please contact us regarding our products' conformity to the European Pharmacopoeia, section 3.1.9 "Silicone elastomers for closures and tubing" Please contact your technical service manager to see whether ELASTOSIL® products are suitable for your projects and applications.

(1) Systemic/intracutaneous toxicity, implantation test (5 days)

(2) Cytotoxicity, sensitization LLNA, pyrogenicity, additional tests upon request

(3) BfR recommendation "XV. Silicone" (BfR = Bundesinstitut für Risikobewertung) (German Institute for Risk Assessment)

(4) FDA 21 CFR § 177.2600 "Rubber articles intended for repeated use" (FDA = Food and Drug Administration)

# SILPURAN® – PLATINUM-CURING SOLID SILICONE RUBBER

Product	Properties	Product Description	Typical Applications	Hardness, Shore A	Measured with a Crosslinker	Tensile Strength (DIN 53 504-S1) [N/mm <sup>2</sup> ]	Elongation at Break (DIN 53 504-S1) [%]	Tear Strength (ASTM D624 B) [N/mm]	USP Class VI <sup>(1)</sup>	ISO 10993 <sup>(2)</sup>	BfR <sup>(3)</sup>	FDA <sup>(4)</sup>
SILPURAN® 8020	Very good mechanical properties	<ul style="list-style-type: none"> <li>Platinum-curing, two-part solid silicone rubber for molding (100:1.5 base/SILPURAN® Crosslinker M)</li> <li>Readily pigmentable</li> <li>Produced in accordance with the WACKER CLEAN OPERATIONS Standard</li> </ul>	<ul style="list-style-type: none"> <li>Medical/pharmaceutical injection-molding applications</li> <li>Highly transparent, durable parts, etc.</li> <li>Compression molding, transfer molding or injection molding</li> </ul>	40	M <sup>(7)</sup>	11.1	820	34	x	x	x	x
				50	M	11.2	760	35	x	x	x	x
				60	M	11.2	670	31	x	x	x	x
				70	M	10.4	650	37	x	x	x	x
SILPURAN® 8030	High tear resistance	<ul style="list-style-type: none"> <li>Platinum-curing, two-part solid silicone rubber for extrusion (100:1.5 base/SILPURAN® Crosslinker X)</li> <li>Readily pigmentable</li> <li>Produced in accordance with the WACKER CLEAN OPERATIONS Standard</li> </ul>	<ul style="list-style-type: none"> <li>Medical/pharmaceutical extrusion applications</li> <li>Highly transparent, durable tubes and catheters, etc.</li> </ul>	40	X <sup>(8)</sup>	9.7	810	30	x	x	x	x
				50	X	10.5	850	35	x	x	x	x
				60	X	10.7	710	39	x	x	x	x
				70	X	9.7	650	41	x	x	x	x

These figures are only intended as a guide and should not be used in preparing specifications. Please contact us regarding our products' conformity to the European Pharmacopoeia, section 3.1.9 "Silicone elastomers for closures and tubing" Please contact your technical service manager to see whether ELASTOSIL® products are suitable for your projects and applications.

(1) Systemic/intracutaneous toxicity, implantation test (5 days)

(2) Cytotoxicity, sensitization LLNA, pyrogenicity, additional tests upon request

(3) BfR recommendation "XV. Silicone" (BfR = Bundesinstitut für Risikobewertung) (German Institute for Risk Assessment)

(4) FDA 21 CFR § 177.2600 "Rubber articles intended for repeated use" (FDA = Food and Drug Administration)

# SILPURAN® – PLATINUM-CURING SOLID SILICONE RUBBER

Product	Properties	Product Description	Typical Applications	Hardness, Shore A	Measured with a Crosslinker	Tensile Strength (DIN 53 504-S1) [N/mm <sup>2</sup> ]	Elongation at Break (DIN 53 504-S1) [%]	Tear Strength (ASTM D624 B) [N/mm]	USP Class VI <sup>(1)</sup>	ISO 10993 <sup>(2)</sup>	BfR <sup>(3)</sup>	FDA <sup>(4)</sup>
SILPURAN® 8630	Low coefficient of dynamic friction; coefficient of friction is up to 70% lower than that of SILPURAN® 8030.	<ul style="list-style-type: none"> <li>Platinum-curing, two-part solid silicone rubber for extrusion (100:1.5 base/SILPURAN® Crosslinker X)</li> <li>Readily pigmentable</li> <li>Produced in accordance with the WACKER CLEAN OPERATIONS Standard</li> </ul>	<ul style="list-style-type: none"> <li>Medical/pharmaceutical extrusion applications</li> <li>Catheters, tubing, etc. with low coefficients of dynamic friction</li> </ul>	60	X	8.0	510	41	x	x	x	x
SILPURAN® AUX 8251 RO		<ul style="list-style-type: none"> <li>Barium sulfate batch (71%)</li> <li>Produced in accordance with the WACKER CLEAN OPERATIONS Standard</li> </ul>	<ul style="list-style-type: none"> <li>X-ray opaque additive for platinum-curing silicone rubber compounds</li> </ul>						x	x	x	x

These figures are only intended as a guide and should not be used in preparing specifications. Please contact us regarding our products' conformity to the European Pharmacopoeia, section 3.1.9 "Silicone elastomers for closures and tubing" Please contact your technical service manager to see whether ELASTOSIL® products are suitable for your projects and applications.

(1) Systemic/intracutaneous toxicity, implantation test (5 days)

(2) Cytotoxicity, sensitization LLNA, pyrogenicity, additional tests upon request

(3) BfR recommendation "XV. Silicone" (BfR = Bundesinstitut für Risikobewertung) (German Institute for Risk Assessment)

(4) FDA 21 CFR § 177.2600 "Rubber articles intended for repeated use" (FDA = Food and Drug Administration)

# SILPURAN® – PEROXIDE-CURING SOLID SILICONE RUBBER

Product	Properties	Product Description	Typical Applications	Hardness, Shore A	Measured with a Crosslinker	Tensile strength (DIN 53 504-S1) [N/mm <sup>2</sup> ]	Elongation at Break (DIN 53 504-S1) [%]	Tear Strength (ASTM D624 B) [N/mm]	USP Class VI <sup>(1)</sup>	ISO 10993 <sup>(2)</sup>	BfR <sup>(3)</sup>	FDA <sup>(4)</sup>
SILPURAN® 8060	Highly flexible, highly transparent, good mechanical properties	<ul style="list-style-type: none"> <li>• Peroxide-curing, two-part solid silicone rubber (base + crosslinker)</li> <li>• Readily pigmentable</li> <li>• Produced in accordance with the WACKER CLEAN OPERATIONS Standard</li> </ul>	<ul style="list-style-type: none"> <li>• Medical/pharmaceutical extrusion and injection molding applications</li> <li>• Seals, tubing, etc.</li> </ul>	40	E <sup>(5)</sup>	9.3	560	23	x	x	x	x
				40	C1 <sup>(6)</sup>	11.4	780	29	x	x	x	x
				50	E	11.0	520	25	x	x	x	x
				50	C1	12.0	640	28	x	x	x	x
				60	E	11.0	470	25	x	x	x	x
				60	C1	10.6	510	26	x	x	x	x
				70	E	11.6	480	29	x	x	x	x
				70	C1	11.0	520	31	x	x	x	x
SILPURAN® 8461	Highly tear resistant, highly transparent	<ul style="list-style-type: none"> <li>• Peroxide-curing, two-part solid silicone rubber (base + crosslinker)</li> <li>• Readily pigmentable</li> <li>• Produced in accordance with the WACKER CLEAN OPERATIONS Standard</li> </ul>	<ul style="list-style-type: none"> <li>• Medical/pharmaceutical extrusion applications</li> <li>• Tear-resistant tubing, etc.</li> <li>• High extrusion rates possible</li> </ul>	60	E	10.5	480	33	x	x	x	x
SILPURAN® AUX 8250 RO		<ul style="list-style-type: none"> <li>• Barium sulfate batch (75%)</li> <li>• Produced in accordance with the WACKER CLEAN OPERATIONS Standard</li> </ul>	<ul style="list-style-type: none"> <li>• X-ray opaque additive for peroxide-curing silicone rubber compounds</li> </ul>						x	x	x	x

These figures are only intended as a guide and should not be used in preparing specifications. Please contact us regarding our products' conformity to the European Pharmacopoeia, section 3.1.9 "Silicone elastomers for closures and tubing" Please contact your technical service manager to see whether ELASTOSIL® products are suitable for your projects and applications.

(1) Systemic/intracutaneous toxicity, implantation test (5 days)  
 (2) Cytotoxicity, sensitization LLNA, pyrogenicity, additional tests upon request  
 (3) BfR recommendation "XV. Silicone" (BfR = Bundesinstitut für Risikobewertung) (German Institute for Risk Assessment)  
 (4) FDA 21 CFR § 177.2600 "Rubber articles intended for repeated use" (FDA = Food and Drug Administration)  
 (5) ELASTOSIL® AUX Crosslinker E (6) ELASTOSIL® AUX Crosslinker C1 (7) SILPURAN® Crosslinker M (8) SILPURAN® Crosslinker X

# PERFECT SERVICE – GLOBALLY CONNECTED, LOCALLY AVAILABLE

## Innovation Through Dialog

Individual services play a decisive role in the healthcare industry. Hardly any other field is as dynamic or innovative. Your market success is determined by the support of a competent and experienced partner who assists you through each phase of product development.

You can tap into the full potential of WACKER's silicone rubber compounds by consulting us on anything from materials development, to tests, pilot series and registration – all in accordance with the latest regulations. All around the world, we support you with our highly experienced specialists, state-of-the-art research labs and application expertise. SILPURAN® and ELASTOSIL® are top-quality, extraordinarily flexible products. A broad range of these products can be customized to meet your individual requirements.

Speak with a WACKER sales manager about how you plan to use SILPURAN® and ELASTOSIL®. These individuals are well acquainted with standard production processes. They also have a profound technical understanding of your requirements, and know how best to incorporate these requirements into the properties of our silicone elastomers. Innovative and custom solutions thrive on dialog between experts.

## Applications Labs

Our technical service engineers will work closely with you and tackle specific questions from actual practice. Worldwide, we offer assistance by finding the optimum product for your specific requirements and by supporting your product development from material selection through to industrial production. Because the labs' primary focus is on medical technology, they possess outstanding expertise in this field.

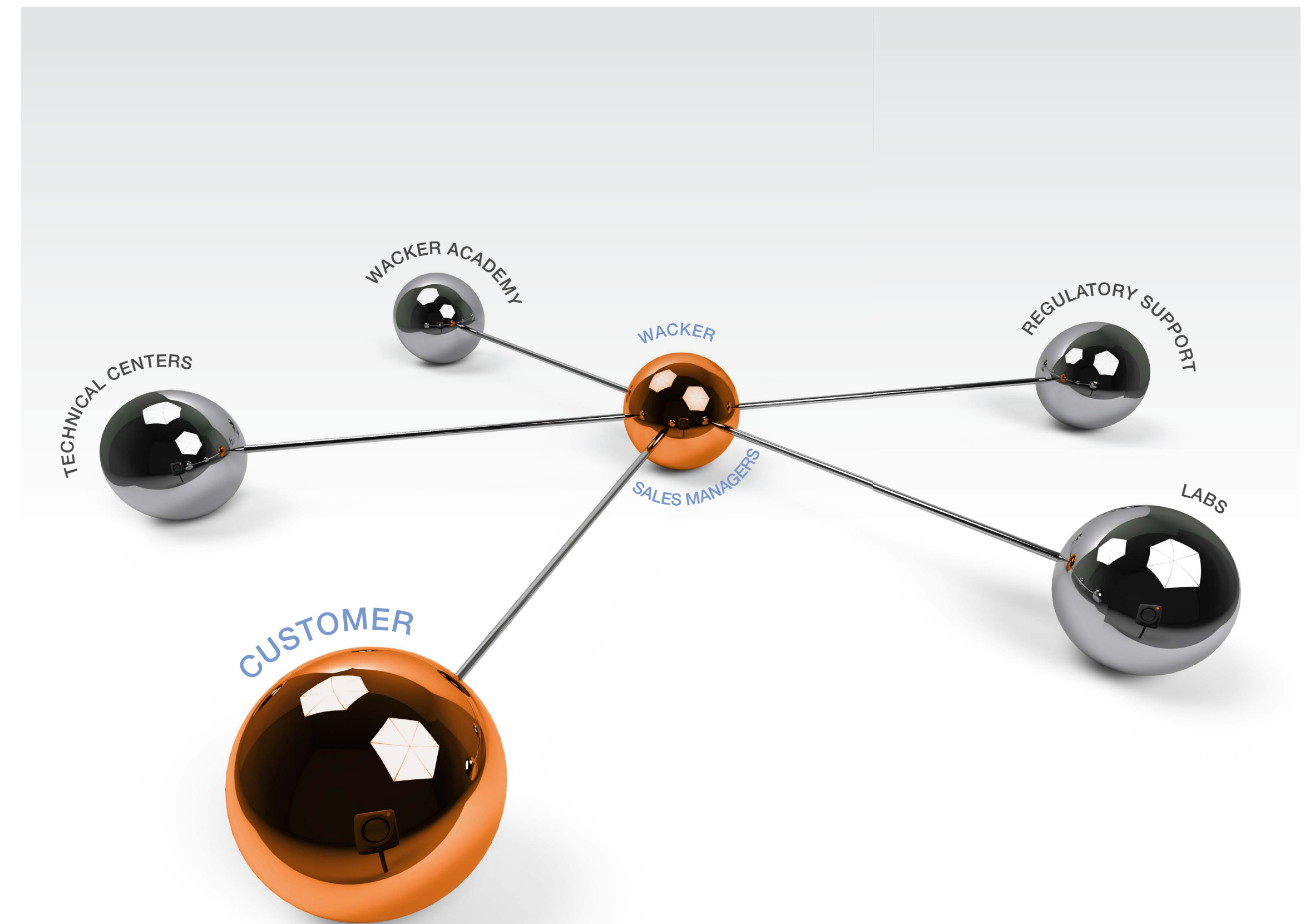

## Technical Centers

We maintain technical centers in all key regions to proactively assist you in any technical matters, from adjusting formulations, to meeting individual requirements, to testing the properties of rubber compounds and cured material. Our technical centers are equipped to perform all relevant analyses, lab tests and trials for you according to international and local standards and regulations.

Besides our local experts, you can also draw on our international knowledge network based on over 50 years of market experience. For example, our pilot plant in Burghausen forms the interface between product and applications expertise. It is equipped with a lab and test facilities, as well as production systems (extrusion and injection molding) for HTV and LSR silicone rubber, and 2-component composite materials.

At our pilot plant, we put our product lines through a range of practical tests as part of their development, testing, modification and optimization. At the same time, we offer extensive advice at every step in the supply chain, and put our pilot plant and all the necessary tools at your disposal. We can also offer on-site consultation at your production plant.

## The WACKER ACADEMY

To transfer its own expertise and market experience, WACKER has founded a unique institution, the WACKER ACADEMY. Here, at a number of sites worldwide, you can take advantage of a versatile, industry-specific seminar program. To access the current program, please go to: [www.wacker.com/wacker-academy](http://www.wacker.com/wacker-academy)

## Regulatory Support

To ensure product safety, we of course offer you regulatory support. Our experts will respond to your questions about environmental, health and regulatory matters such as the following:

- Suitability for contact with food products (e.g. BfR, FDA)
- Pharmaceutical and medical applications (e.g. European Pharmacopeia and US Pharmacopeia)
- National and international directives and regulations (e.g. the KTW Guideline, EU-RoHS, REACH)
- Specific customer requirements (e.g. banned substance and substances avoidance lists)
- Toxicology and ecotoxicology
- Risk analysis

## Infoline

- We have set up an information hotline so that you can start talking with us quickly and easily. For all questions concerning WACKER silicones and related products and services, just call us or email us. You will be redirected to a specialist who can answer your questions.
- **Europe and the Middle East**
- Infoline Germany  
**0800-6279-800**
- Infoline International  
**+49 89 6279-1741**
- Email: [info.silicones@wacker.com](mailto:info.silicones@wacker.com)
- **NAFTA Region –  
Canada, Mexico and the USA**
- Infoline **+1 888-922-5374  
(+1 888-WACKER 4 U)**
- Email: [info.usa@wacker.com](mailto:info.usa@wacker.com)

# CREATING TOMORROW'S SOLUTIONS

## A Diverse Array of Products For Growing Markets

Our product portfolio ranges from silicones, binders and polymeric additives to bioengineered pharmaceutical actives. In addition, we offer hyperpure silicon for semiconductors and solar applications.

## Innovations That Improve The Quality of Life

As a technology leader focusing on sustainability, WACKER promotes products and ideas that offer considerable value-added potential to ensure that current and future generations enjoy a better quality of life, based on energy efficiency and protection of the climate and environment.

## Global Knowledge For Local Markets

When you work with WACKER, you have 100 years of chemical expertise at your disposal, with access to the research findings and best practices of our experts throughout the world. Our knowledge base consists of a network of 23 technical centers, 14 training centers and our basic research center.

**And most importantly: we are there. Worldwide. Wherever and whenever you need us.**

**Our local specialists know your markets and speak your language. By working with them, you will find innovative solutions that win over your customers and make you more competitive.**

### Follow us:

Find us on LinkedIn, YouTube and Twitter. We'll keep you up to date on the latest issues.



All figures are based on fiscal 2020.



## Silicones and Polymers

3,200 specialty products from organic and inorganic chemistry



## Global Market Leader

In dispersions and dispersible polymer powders based on vinyl acetate-ethylene (VAE), in building-protection silicones and in the production of cyclodextrin and cystein.



## Globally Active

- Sites worldwide
- Headquartered in Munich
- 26 production sites in Europe, Asia and the Americas
- 23 technical centers
- 14 WACKER ACADEMY training centers
- 52 sales offices



**Employees: 14,300**



## Total Sales

€4.69 billion



**WACKER**

**Wacker Chemie AG**

Hanns-Seidel-Platz 4  
81737 Munich, Germany  
[www.wacker.com/contact](http://www.wacker.com/contact)

[www.wacker.com](http://www.wacker.com)

Follow us on:   

ELASTOSIL® is a registered trademark of Wacker Chemie AG.

SILPURAN® is a registered trademark of Wacker Chemie AG.

The data presented in this medium are in accordance with the present state of our knowledge but do not absolve the user from carefully checking all supplies immediately on receipt. We reserve the right to alter product constants within the scope of technical progress or new developments. The recommendations made in this medium should be checked by preliminary trials because of conditions during processing over which we have no control, especially where other companies' raw materials are also being used. The information provided by us does not absolve the user from the obligation of investigating the possibility of infringement of third parties' rights and, if necessary, clarifying the position. Recommendations for use do not constitute a warranty, either express or implied, of the fitness or suitability of the product for a particular purpose.