

S6081 June
WASSCE 2008
TECHNICAL
DRAWING 1
2 $\frac{1}{2}$ hours

Name:.....

Index Number:.....

THE WEST AFRICAN EXAMINATIONS COUNCIL
West African Senior School Certificate Examination

June 2008

TECHNICAL DRAWING 1

2 $\frac{1}{2}$ hours

Do not open this booklet until you are told to do so. While you are waiting, write your name and index number in the spaces provided at the top right-hand corner of this booklet and thereafter, read the following instructions carefully. This paper consists of two sections, A and B, answer Section A on your objective test answer sheet, and section B on the drawing paper provided. Section A will last for 1 hour after which the answer sheet will be collected. Do not start Section B until you are told to do so.

Section B will last for 1 $\frac{1}{2}$ hours.

SECTION A
OBJECTIVE TEST
[40 marks]

1 hour

- Use HB pencil throughout.
- If you have got a blank answer sheet, complete its top section as follows.
 - In the space marked *Name*, write in capital letters your **surname** followed by your **other names**.
 - In the spaces marked *Examination*, *Year*, *Subject* and *Paper*, write 'WASSCE', '2008 JUNE', 'TECHNICAL DRAWING' and '1', respectively.
 - In the box marked *Index Number*, write your **index number** vertically in the spaces on the left-hand side. There are numbered spaces in line with each digit. Shade carefully the space with the same number as each digit.
 - In the box marked *Paper Code*, write the digits 60812 in the spaces on the left-hand side. Shade the corresponding numbered spaces in the same way as for your index number.
 - In the box marked *Sex*, shade the space marked M if you are **male**, or F if you are **female**.
- If you have got a pre-printed answer sheet, check that the details are correctly printed, as described in 2 above. In the boxes marked *Index Number*, *Paper Code* and *Sex*, reshade each of the shaded spaces.
- An example is given below. This is for a male candidate whose name is **Chukwuma Adekunle CIROMA**, whose index number is 4251102068 and who is offering **Technical Drawing 1**.

THE WEST AFRICAN EXAMINATIONS COUNCIL

PRINT IN BLOCK LETTERS

Name: CIROMA CHUKWUMA ADEKUNLE Examination: WASSCE Year: 2008 JUNE
Surname Other Names

Subject: TECHNICAL DRAWING Paper: 1

INDEX NUMBER	
4	0 1 2 3 4 5 6 7 8 9
2	0 1 2 3 4 5 6 7 8 9
5	0 1 2 3 4 5 6 7 8 9
1	0 1 2 3 4 5 6 7 8 9
1	0 1 2 3 4 5 6 7 8 9
0	0 1 2 3 4 5 6 7 8 9
2	0 1 2 3 4 5 6 7 8 9
0	0 1 2 3 4 5 6 7 8 9
6	0 1 2 3 4 5 6 7 8 9
8	0 1 2 3 4 5 6 7 8 9

PAPER CODE	
6	0 1 2 3 4 5 6 7 8 9
0	0 1 2 3 4 5 6 7 8 9
8	0 1 2 3 4 5 6 7 8 9
1	0 1 2 3 4 5 6 7 8 9
1	0 1 2 3 4 5 6 7 8 9
2	0 1 2 3 4 5 6 7 8 9

SEX
Indicate your sex by shading the space marked M (for Male) or F (for Female) in this box: M F
<input type="checkbox"/> <input type="checkbox"/>

- INSTRUCTIONS TO CANDIDATES
- Use grade HB pencil throughout.
 - Answer each question by choosing one letter and shading it like this: [A] [B] [C]
 - Erase completely any answers you wish to change.
 - Leave extra spaces blank if the answer spaces provided are more than you need.
 - Do not make any markings across the heavy black marks at the right-hand edge of your answer sheet.

For Supervisors only.
If candidate is absent shade this space:

Answer forty questions in all: all the questions in Part 1 and ten questions only from either Part IIA or Part IIB.

Each question is followed by four options lettered A to D. Find out the correct option for each question and shade in pencil on your answer sheet, the answer space which bears the same letter as the option you have chosen. Give only one answer to each question. An example is given below.

The part of a building immediately above a window frame is the

- A. wall plate.
- B. king post.
- C. lintel.
- D. wall

The correct answer is lintel which is lettered C and therefore answer space C would be shaded.

[A] [B] [C] [D]

Think carefully before you shade the answer spaces; erase completely any answer(s) you wish to change.

Do all rough work on this question paper.

PART 1

Answer all the questions in this part.

1. Which of the following shows a centre line?



A



B



C



D

2. Which of the following shows the curve of interpenetration of two unequal cylinders?

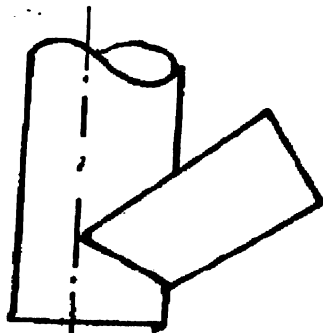

A

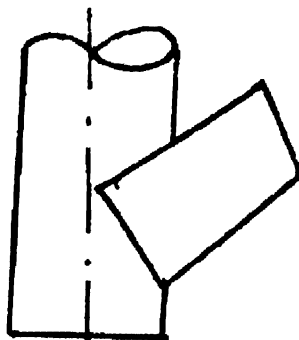

B

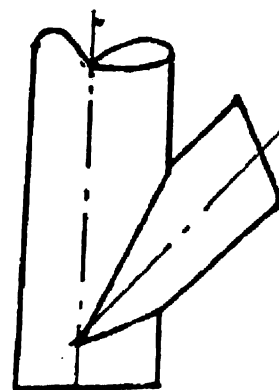

C

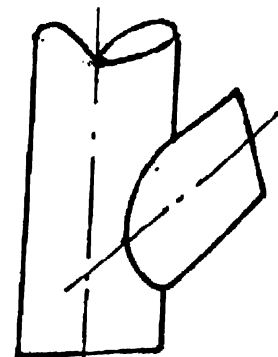

D

3. How many faces has a solid hexagonal pyramid?

- A. 4
- B. 5
- C. 6
- D. 7

3

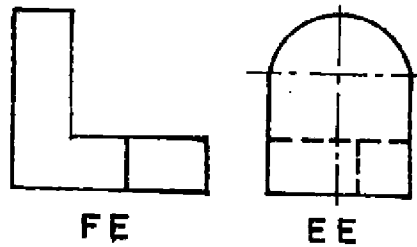

4. Which of the following is the correct pictorial drawing of the bracket shown above?

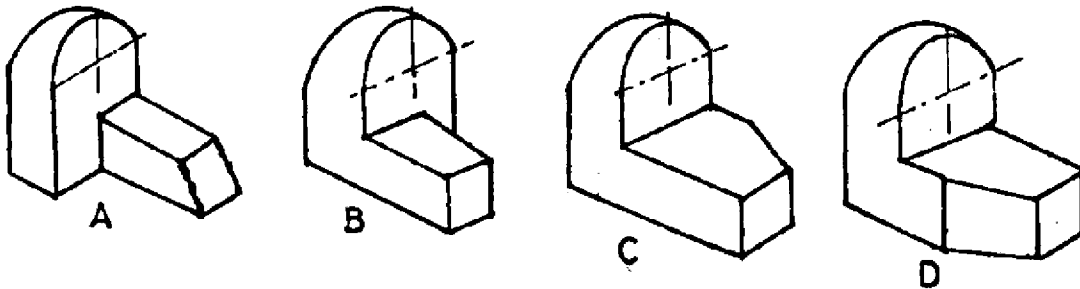

5. Which of the following is **not** a type of orthographic projection?

- A. First angle.
- B. Third angle.
- C. Isometric
- D. Auxiliary

6. The figure below shows isometric axes **OP**, **OQ** and **OR**. What is the value of angle θ ?

- A. 15°
- B. 25°
- C. 30°
- D. 45°

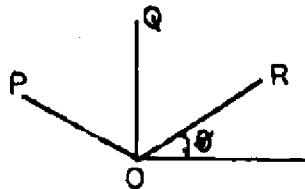

7. The figure below shows the beginning of the construction of a/an

- A. cylinder.
- B. truncated cone.
- C. regular polygon.
- D. ellipse.

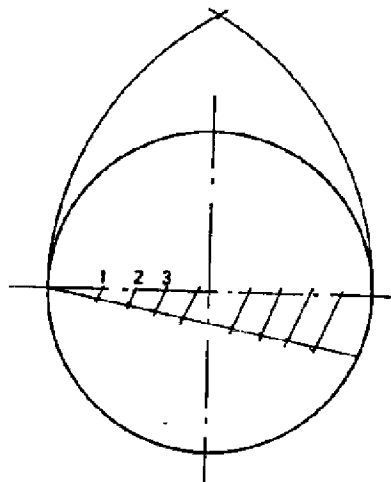

4

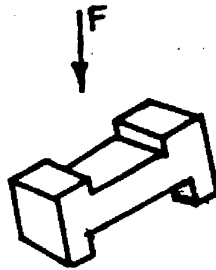

8. The plan of the figure above in the direction of arrow F is



A



B



C



D

9. Which of the following is required to construct the polygon below?

- A. Distance across flats
- B. Distance across corners
- C. Internal angle
- D. Length of one side

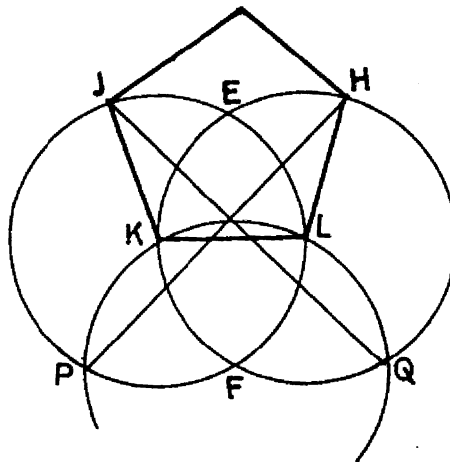

10. Which of the following drawing instruments is used to reproduce shapes?

- A. Compass
- B. Template
- C. Divider
- D. Protractor

11. Which of the following curves has eccentricity greater than one?

- A. T
- B. S
- C. V
- D. U

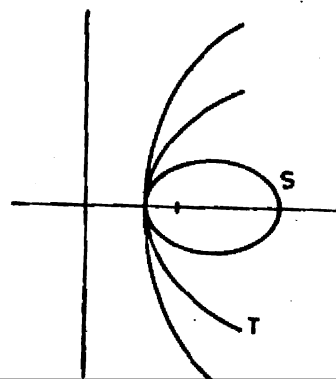

12. If the crank **OK** in the diagram below moves anticlockwise the link **KP** will

- A. rotate at **Q**
- B. slide towards **K**
- C. slide towards **P**
- D. remain stationary

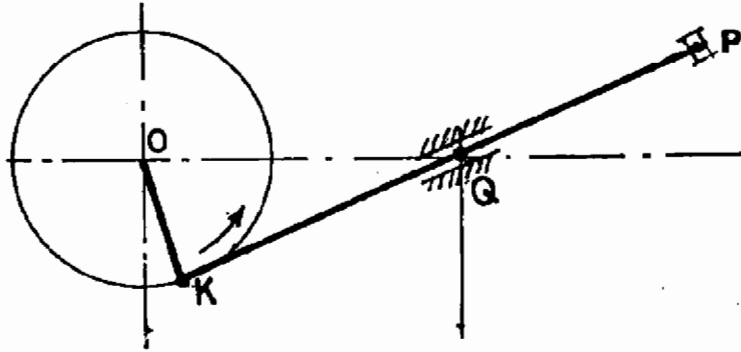

13. Which of the following is an example of a frustum?

- A. Water bucket
- B. Electric bulb
- C. Lantern
- D. Fluorescent tube

14. The development of a closed square prism will have

- A. 4 rectangles and 4 squares.
- B. 2 squares and 2 rectangles.
- C. 4 rectangles and 2 squares.
- D. 4 squares and 2 rectangles.

15. If a length of 1 metre on land is represented by 2 cm on a drawing, what is the ratio of the scale used?

- A. 1:20
- B. 1:40
- C. 1:50
- D. 1:100

16. Which of the following has eight triangular faces?

- A. Octahedron
- B. Tetrahedron
- C. Hexahedron
- D. Decahedron

17. What type of section is suitable for showing the cross-section of a long bar?

- A. Removed
- B. Half
- C. Offset
- D. Revolved

18. Which of the following is the true shape of the section S-S above if the object is spherical?

- A. Circle
- B. Ellipse
- C. Triangle
- D. Sphere

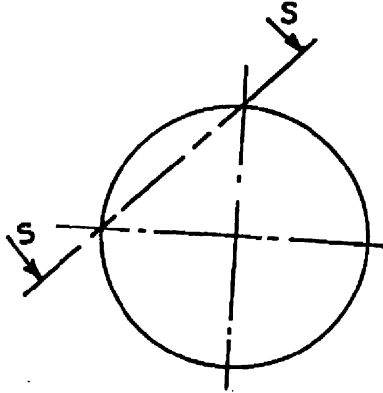

19. A conic section whose eccentricity is $\frac{4}{3}$ is a/an

- A. hyperbola.
- B. parabola.
- C. sphere.
- D. circle.

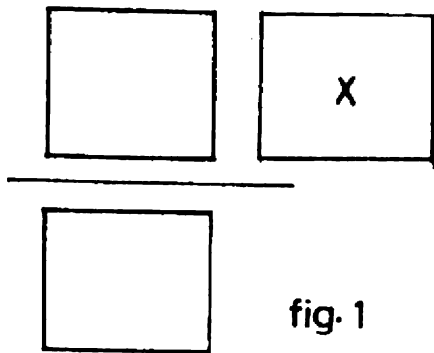

fig. 1

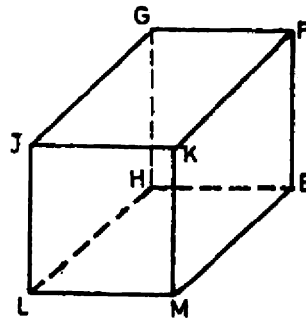
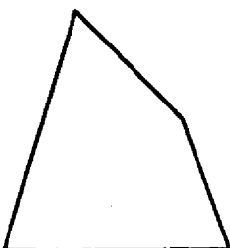

fig. 2

20. If the rectangular tank in figure 2 above is projected in first angle, the view X in figure 1 represents surface

- A. JKML
- B. GHEF
- C. GFKJ
- D. EFKM

21. Which of the following polygons has one of its internal angles more than 180° ?



A

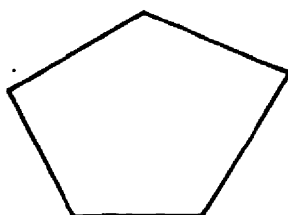

B

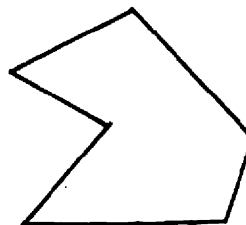

C

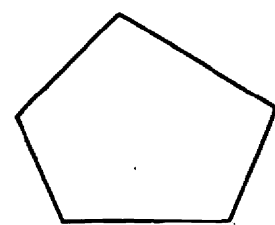

D

22. Which of the following is a circumscribed circle?

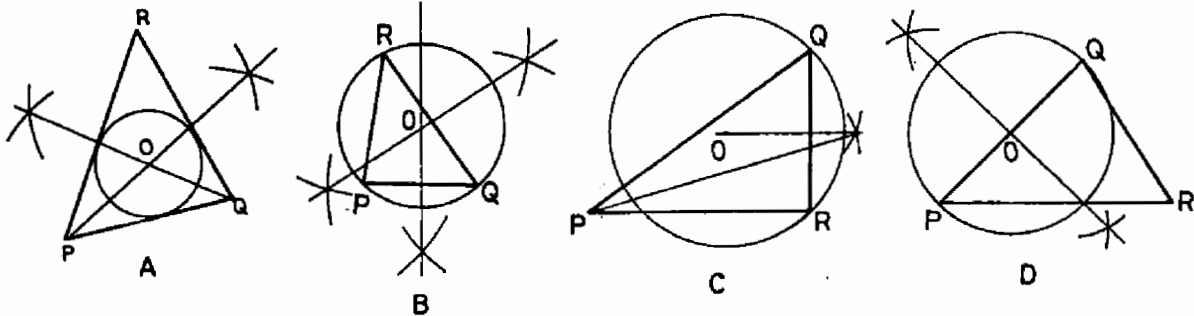

23. If a right cone is truncated by a cutting plane which is perpendicular to its axis, then the true shape of the cut surface is a/an

- A. ellipse.
- B. circle.
- C. semi-circle.
- D. parabola.

24. The figure below shows a trough. It comprises

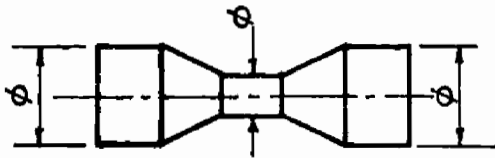

- A. two truncated cones and three truncated cylinders.
- B. two truncated cones and three cylinders.
- C. two cones and three cylinders.
- D. three cones and three cylinders.

25. Which of the following plane figures is not represented in the figure below?

- A. Trapezium
- B. Square.
- C. Rhombus
- D. Rectangle

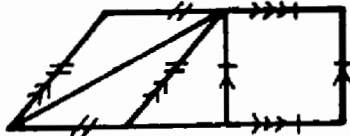

26. The point where a line penetrates a plane is called the

- A. incident.
- B. trace.
- C. axis.
- D. directrix

27. Which of the following is not a type of scale?
- Scale of chords
 - Plain scale
 - Diagonal scale
 - Parallel scale
28. The head lamp of a car is constructed by applying the principle of
- hyperbola.
 - parabola.
 - involute.
 - cycloid.
29. The construction below cannot be used to

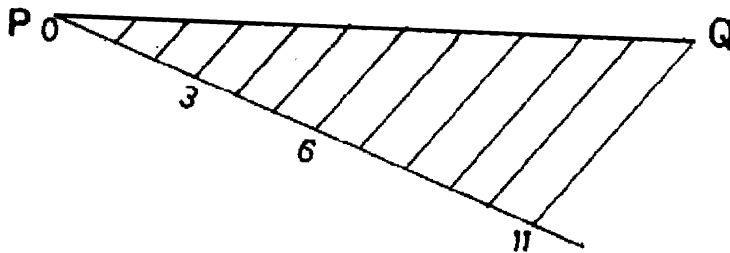

- determine the mid-point of line PQ.
- divide line PQ into eleven equal parts.
- construct a triangle whose sides are in ratio 3:5:3
- construct a triangle whose perimeter is equal to line PQ.

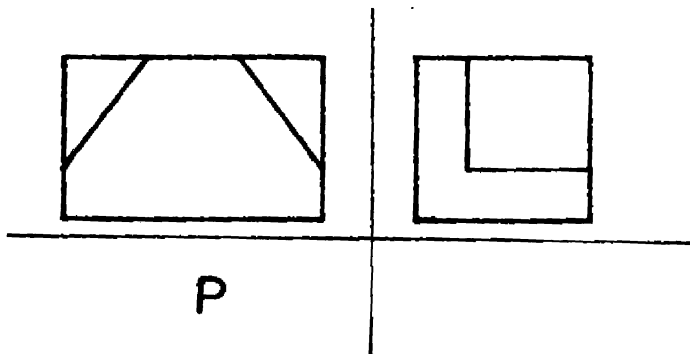

30. The figure above shows a box in orthographic view. The correct view in the position P is

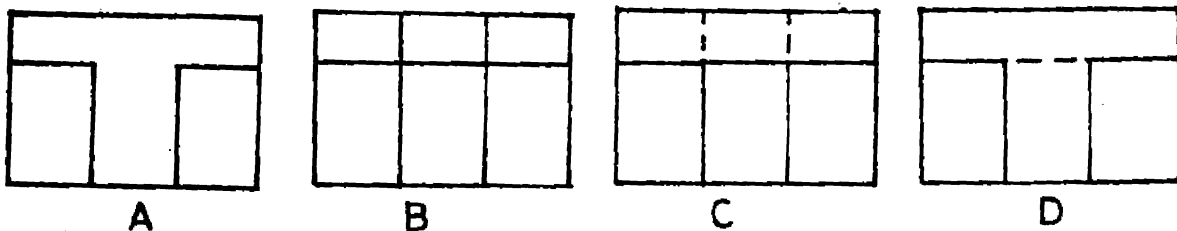

PART II A
BUILDING DRAWING (Optional)

31. The figure below shows part of a section through a roof and wall. The part labelled S is called

- A. purlin.
- B. reinforced concrete.
- C. wallplate.
- D. lintel.

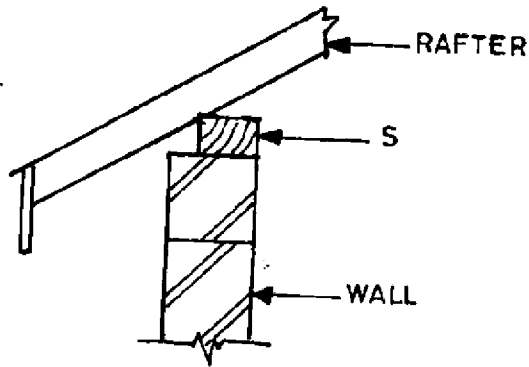

Use the figure below to answer questions 32 and 33.

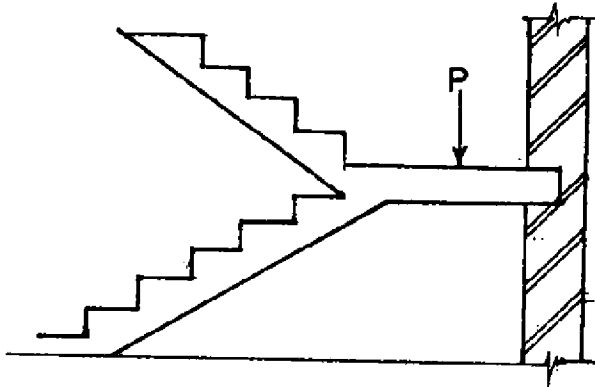

32. The part labelled P is the
- A. going.
 - B. thread.
 - C. landing.
 - D. flight.
33. How many flights are in the stair case?
- A. Six
 - B. Five
 - C. Four
 - D. Two
34. Which of the following is not a type of door?
- A. Raft
 - B. Brazen
 - C. Battern
 - D. Ledged

35. The material symbol shown below represents

- A. wood
- B. brick
- C. concrete
- D. glass

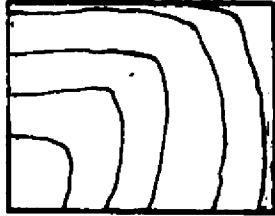

36. In the double casement window shown below the stile is labelled

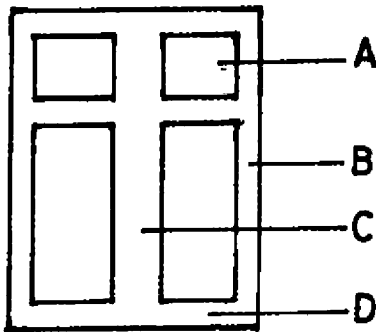

37. Which of the following is not a member of a roof?

- A. Queen post
- B. Jamb
- C. Purlin
- D. Wallplate

38. In the staircase shown below identify the part labelled X.

- A. Riser
- B. Flight.
- C. Going
- D. Landing

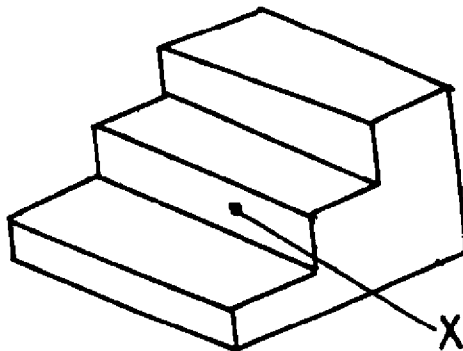

39. Soffit is a member of a

- A. foundation.
- B. roof.
- C. floor.
- D. wall.

How to get WAEC Technical Drawing Past Questions

To get the complete and more recent copy of the WAEC Technical Drawing TD Past Questions booklet for Objective Test, Essay, Building Construction/Practical Drawing.

Take Note of the following step

1. **MAKE A CALL.**
Call or Whatsapp us on 08051311885 for account number to make payment and how to received your PDF Copy
2. **MODE OF PAYMENT.**
Mobile Transfer, POS or Direct Bank Deposit.
3. **AFTER PAYMENT.**
Send us the following
Depositor Name:
Name of Product Paid for:
Valid email address.
4. **DELIVERY ASSURANCE.**
We will deliver the past question to you, 10 minutes after confirmation of payment to the email address you will send to us.

WHAT OTHERS ARE DOWNLOADING

[WAEC Past Questions](#)

[NECO Past Questions](#)

[Primary School Past Questions](#)

[Junior Secondary School Past Questions](#)

[Senior Secondary School Past Questions](#)

[Lesson Note](#)

[Nigeria Scheme of Work](#)