

## SOME IMPORTANT BOOKS ON PHYSICS

Brij Lal & Subrahmanyam  
**HEAT & THERMODYNAMICS**  
**PROPERTIES OF MATTER**  
**ATOMIC AND NUCLEAR PHYSICS**  
**NUMERICAL PROBLEMS IN PHYSICS**  
**A TEXTBOOK OF OPTICS**  
**THERMAL AND STATISTICAL PHYSICS**  
**NUMERICAL NEXAMPLES INPHYSICS**  
K.K. Tiwari  
**ELECTRICITY AND MAGETISM WITH**  
**ELECTRONICS**  
D.N. Vasudeva  
**FUNDAMENTALS OF MAGNETISM ABND**  
**ELECTRICITY**  
D. Chattopadhyay & P.C. Rakshit  
**QUANTUM MECHANICS, STATISTICAL**  
**MECHANICS AND SOLID STATE**  
**PHYSICH**  
M.K. Bagde & S.P. Singh  
**QUANTUM MECHANICS**  
R. Murugesan  
**MODERN PHYSICS**  
**SOLVED PROBLEMS IN MODERN**  
**PHYSICS**  
**ELECTRICITY AND MAGNETISM**  
**PROPERTIES OF MATTER**  
**OPTICS AND SPECTROSOCPY**  
D.S. Mathour  
**ELEMENTS OF PROPERTIES OF MATTER**  
**MECHANICS**  
B.L. Theraja  
**BASIC ELECTRICS (Solid State)**  
**ELECTRICAL TECHNOLOGY (Vol. IV)**  
**ELECTRONIC DEVICES & CIRCUIT**  
V.K. Mehta  
**PRINCIPLES OF ELECTRINICS**  
Ashok K. Ganguli  
**A TEXTBOOK OF WAVES AND**  
**OSCILLATIOPNS**  
P.N. Arora & M.C. Arora  
**CHAND'S DICTIONARY OF PHYSICS**  
A.S. Vasudeva  
**MODERN ENGINEERING PHYSICS**  
**CONCEPTS OF MODERN ENGINEERING**  
**PHYSICS**

Y.R. Waghmare  
**INTRODUCTORY QUANTUM MECHANICS**  
S.N. gHOSHAL  
**ATOMIC AND NUCLEAR PHYSICS**  
**VOLUME I & II**  
D.N. Vasudeva  
**FUNDAMENTAL OF MANAGETISM**  
**& ELECTRICITY**  
K.C. Lal & S.I. Ahmed  
**A TEXTBOOK OF MODERN PHYSICS**  
C.L. Arora  
**B.Sc. PHYSICS-- VOLUME I, II & III**  
(Refereshor Course)  
B.Sc. PRACTICAL PHYSICS  
**SIMPLIFIED COURSE IN B.S.C. PHYSICS**  
(In Three Volumes)  
D.C. Sarker  
**BASIC RADIO ELECTRONICS**  
**MICROWAVE PROPAGATION AND**  
**TECHNIQUES**  
S.K. Sarker  
**OPTICAL FIBERS & FIBRE OPTICAL**  
**COMMUNICAITON SYSTEMS**  
R.K. Puri & v.k. Babbar  
**SOLID STATE PHYSICS & ELECTRONICS**  
Hamam Singh  
**B.Sc. PRACTICAL PHYSICS**  
P.G. Kshirsager & M.N. Avadhanulu  
**A TEXTBOOK OF ENGINEERING PHYSICS**  
M.C. Jain  
**OBJECTIVE PHYSICS**  
**PHYSICS FOR IIT-JEE**  
M.N. Avadhanulu & n.k. Bhagdiker  
**NUMERICAL EXAMPLES IN ENGINEERING**  
**PHYSICS**  
S.G. Pimpale  
**THEORY OF SPACE, TIME AND**  
**GRAVITATION**  
K.C. Jain  
**NUMERICAL PROBLEM IN PHYSICS**  
S.K. Sarker  
**OPERATINAL AMPLIFIERS AND THEIR**  
**APPLICATIONS**  
Kamal Singh  
**ELEMENT OF STATISTICAL MECHANICS**  
Prakash Manikpure  
**A TEXTBOOK OF APPLIED PHYSCIS FOR**  
**POLYTECHNICS**  
S.P. Singh & M.K. Bagde  
**A TEXTBOOK OF FIRST YEAR PHYSICS**

ISBN 81-219-0467-6



9 788121 904674

Rs. 110.00

16 056 E

# A TEXTBOOK OF OPTICS

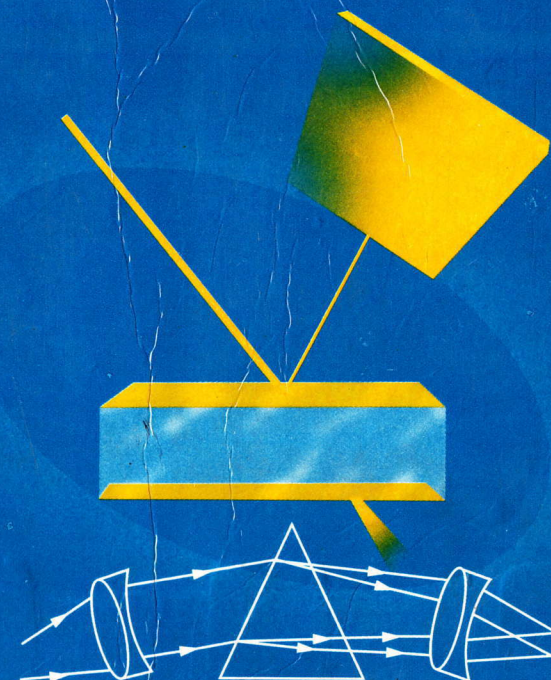

N. SUBRAHMANYAM  
BRIJ LAL

**S. CHAND & COMPANY LTD.**

7361, RAMNAGAR, NEW DELHI-110055

Visit us at: <http://www.schandgroup.com>  
Write to us: [schandco@iasdi01.vsnl.net.in](mailto:schandco@iasdi01.vsnl.net.in)

12. A 100 candle power lamp hangs 2 metres vertically above the centre of a circular table of 2 metres diameter. Determine the intensity of illumination at a point on the edge of the table. (Delhi 1989)

[Ans. 17.88 lumens/sq metre]

13. Two lamps of 100 CP and 25 CP are placed one metre apart. At what points on the line passing through them is the illumination due to each of them the same? (Madras 1993)

[Ans. (i) 66.67 cm from 100 CP lamp in between the line joining the two sources (ii) 1 metre from 25 CP lamp and 2 metres from 100 CP lamp]

14. Write short notes on :

(i) Flicker photometer

(Mysore 1991)

(ii) Lummer-Brodhum photometer.

## NATURE OF LIGHT

### 7.1 NEWTON'S CORPUSCULAR THEORY

The branch of optics that deals with the production, emission and propagation of light, its nature and the study of the phenomena of interference, diffraction and polarisation is called physical optics. The basic principles regarding the nature of light were formulated in the latter half of the seventeenth century. Until about this time, the general belief was that light consisted of a stream of particles called corpuscles. These corpuscles were given out by a light source (an electric lamp, a candle, sun etc.) and they travelled in straight lines with large velocities. The originator of the **emission or corpuscular theory** was Sir Isaac Newton. According to this theory, a luminous body continuously emits tiny, light and elastic particles called corpuscles in all directions. These particles or corpuscles are so small that they can readily travel through the interstices of the particles of matter with the velocity of light and they possess the property of reflection from a polished surface or transmission through a transparent medium. When these particles fall on the retina of the eye, they produce the sensation of vision. On the basis of this theory, phenomena like rectilinear propagation, reflection and refraction could be accounted for, satisfactorily. Since the particles are emitted with high speed from a luminous body, they, in the absence of other forces, travel in straight lines according to Newton's second law of motion. This explains rectilinear propagation of light.

### 7.2 REFLECTION OF LIGHT ON CORPUSCULAR THEORY

Let  $SS'$  be a reflecting surface and  $IM$  the path of a light corpuscle approaching the surface  $SS'$ . When the corpuscle comes within a very small distance from the surface (indicated by the dotted line  $AB$ ) it, according to the theory, begins to experience a force of repulsion due to the surface (Fig. 7.1).

The velocity  $v$  of the corpuscle at  $M$  can be resolved into two components  $x$  and  $y$  parallel and perpendicular to the reflecting surface. The force of repulsion acts perpendicular to the surface  $SS'$  and consequently the component  $y$  decreases up to  $O$  and becomes zero at  $O$  the point of incidence on the surface  $SS'$ . Beyond  $O$ , the perpendicular component of the velocity increases up to  $N$ . Its magnitude will be again  $y$  at  $N$  but in the opposite direction. The parallel component  $x$  remains the same throughout. Thus at  $N$ , the corpuscle again possesses two components of velocity  $x$  and  $y$  and the resultant direction of the corpuscle is along  $NR$ . The velocity of the corpuscle will be  $v$ . Between the surfaces  $AB$  and  $SS'$ , the path of the corpuscle is convex to the reflecting surface. Beyond the point  $N$ , the particle moves unaffected by the presence of the surface  $SS'$ .

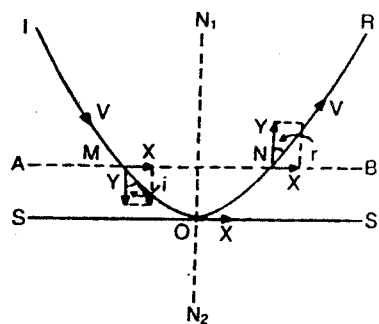

Fig. 7.1

$$x = v \sin i = v \sin r, \quad \therefore i = r$$

Further, the angles between the incident and the reflected paths of the corpuscles with the normals at  $M$  and  $N$  are equal. Also, the incident and the reflected path of the corpuscle and the normal lie in the same plane viz. the plane of the paper.

### 7.3 REFRACTION OF LIGHT ON CORPUSCULAR THEORY

Newton assumed that when a light corpuscle comes within a very small limiting distance from the refracting surface, it begins to experience a force of attraction towards the surface. Consequently the component of the velocity perpendicular to the surface increases gradually from  $AB$  to  $A'B'$ .  $SS'$  is the surface separating the two media (Fig. 7.2).  $IM$  is the incident path of the corpuscle travelling in the first medium with a velocity  $v$  and incident at an angle  $i$ .  $AB$  to  $A'B'$  is a narrow region within which the corpuscle experiences a force of attraction.  $NR$  is the refracted path of the corpuscle. Let  $v \sin i$  and  $v \cos i$  be the components of the velocity of the corpuscle at  $M$  parallel and perpendicular to the surface. The velocity parallel to the surface increases by an amount which is independent of the angle of incidence, but which is different for different materials. Let  $v$  and  $v'$  be the velocity of the corpuscle in the two media and  $r$  the angle of refraction in the second medium.

As the parallel component of the velocity remains the same,

$$v \sin i = v' \sin r$$

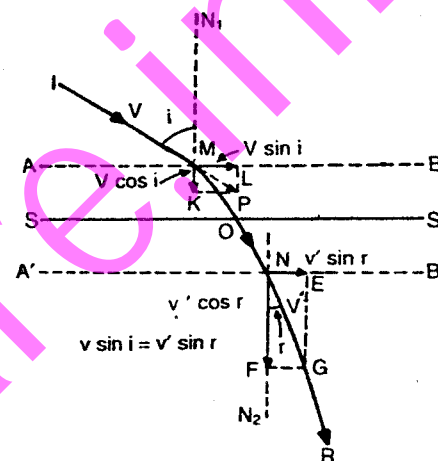

Fig. 7.2

$$\frac{\sin i}{\sin r} = \frac{v'}{v}$$

or

$$\begin{aligned} &= \frac{\text{velocity of light in the second medium}}{\text{velocity of light in the first medium}} \\ &= {}_1\mu_2 \quad (\text{refractive index of the second} \\ &\quad \text{medium with reference to the} \\ &\quad \text{the first medium}) \end{aligned}$$

Thus, the sine of the angle of incidence bears a constant ratio to the sine of the angle of refraction. This is the well known Snell's law of refraction. If  $i > r$ , then  $v' > v$ , i.e., the velocity of light in a denser medium like water or glass is greater than that in a rarer medium such as air.

But the results of Foucault and Michelson on the velocity of light show that the velocity of light in a denser medium is less than that in a rarer medium. Newton's corpuscular theory is thus untenable. This is not the only ground on which Newton's theory is invalid. In the year 1800, Young discovered the phenomenon of interference of light. He experimentally demonstrated that under certain conditions, light when added to light produces darkness. The phenomena belonging to this class cannot be explained, if following Newton, it is supposed that light consists of material particles. Two corpuscles coming together cannot destroy each other.

Another case considered by Newton was that of simultaneous reflection and refraction. To explain this he assumed that the particles had fits

so that some were in a state favourable to reflection and others were in a condition suitable for transmission. No explanation of interference, diffraction and polarization was attempted because very little was known about these phenomena at the time of Newton. Further, the corpuscular theory has not given any plausible explanation about the origin of the force of repulsion or attraction in a direction normal to the surface.

#### 7.4 ORIGIN OF WAVE THEORY

The test and completeness of any theory consists in its ability to explain the known experimental facts, with minimum number of hypotheses. From this point of view, the corpuscular theory is above all prejudices and with its help rectilinear propagation, reflection and refraction could be explained.

By about the middle of the seventeenth century, while the corpuscular theory was accepted, the idea that light might be some sort of wave motion had begun to gain ground. In 1679, Christian Huygens proposed the wave theory of light. According to this, a luminous body is a source of disturbance in a hypothetical medium called ether. This medium pervades all space. The disturbance from the source is propagated in the form of waves through space and the energy is distributed equally, in all directions. When these waves carrying energy are incident on the eye, the optic nerves are excited and the sensation of vision is produced. These vibrations in the hypothetical ether medium according to Huygens are similar to those produced in solids and liquids. They are of a mechanical nature. The hypothetical ether medium is attributed the property of transmitting elastic waves, which we perceive as light. Huygens assumed these waves to be longitudinal, in which the vibration of the particles is parallel to the direction of propagation of the wave.

Assuming that energy is transmitted in the form of waves, Huygens could satisfactorily explain reflection, refraction and double refraction noticed in crystals like quartz or calcite. However, the phenomenon of polarization discovered by him could not be explained. It was difficult to conceive unsymmetrical behaviour of longitudinal waves about the axis of propagation. Rectilinear propagation of light also could not be explained on the basis of wave theory, which otherwise seems to be obvious according to corpuscular theory. The difficulties mentioned above were overcome, when Fresnel and Young suggested that light waves are transverse and not longitudinal as suggested by Huygens. In a transverse wave, the vibrations of the ether particles take place in a direction perpendicular to the direction of propagation. Fresnel could also explain successfully the rectilinear propagation of light by combining the effect of all the secondary waves starting from the different points of a primary wave front.

#### 7.5 WAVE MOTION

Before proceeding to study the various optical phenomena on the basis of Huygens wave theory, the characteristics of simple harmonic motion (the simplest form of wave motion) and the composition or superposition of two or more simple harmonic motions are discussed. The propagation of a simple harmonic wave through a medium can be transverse or longitudinal. In a transverse wave, the particles of the medium vibrate perpendicular to the direction of propagation and in a longitudinal wave, the particles of the medium vibrate parallel to the direction of propagation. When a stone is dropped on the surface of still water, transverse waves are produced. Propagation of sound through atmospheric air is in the form of longitudinal waves. When a wave is propagated through a medium, the particles of the medium are displaced from their mean positions of rest and restoring forces come into play. These restoring forces are due to the elasticity of the medium, gravity and surface tension. Due to the periodic motion of the particles of the medium, a wave motion is produced. At any instant, the contour of all the particles of the medium constitutes a wave.

Let  $P$  be a particle moving on the circumference of a circle of radius  $a$  with a uniform velocity  $v$  (Fig. 7.3). Let  $\omega$  be the uniform angular velocity of the particle ( $v = a\omega$ ). The circle along which  $P$  moves is called the circle of reference. As the particle  $P$  moves round the circle continuously with uniform velocity, the foot of the perpendicular  $M$ , vibrates along the diameter  $YY'$  or  $(XX')$ . If the motion of  $P$  is uniform, then the motion of  $M$  is periodic *i.e.*, it takes the same time to vibrate once between the points  $Y$  and  $Y'$ . At any instant, the distance of  $M$  from the centre  $O$  of the circle is called the displacement. If the particle moves from  $X$  to  $P$  in time  $t$ , then  $\angle POX = \angle MPO = \theta = \omega t$ .

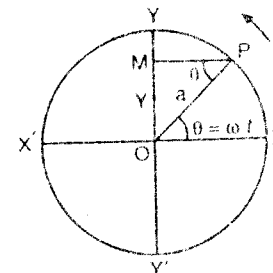

Fig. 7.3

From the  $\Delta MPO$ ,

$$\sin \theta = \sin \omega t = \frac{OM}{a}$$

or

$$OM = y = a \sin \omega t$$

$OM$  is called the displacement of the vibrating particle. The displacement of a vibrating particle at any instant can be defined as its distance from the mean position of rest. The maximum displacement of a vibrating particle is called its amplitude.

$$\therefore \text{Displacement} = y = a \sin \omega t \quad \dots (1)$$

$$\frac{x^2}{a^2} + \frac{y^2}{b^2} - \frac{2xy}{ab} = 0$$

or 
$$\frac{x}{a} - \frac{y}{b} = 0$$

or 
$$y = \left(\frac{b}{a}\right)x \quad \dots(v)$$

This represents the equation of a straight line  $BD$  (Fig. 7.9) i.e., the particle vibrates simple harmonically along the line  $DB$ .

(ii) If  $\alpha = \pi$ ;  $\sin \alpha = 0$ ;

$$\cos \alpha = -1$$

$$\therefore \frac{x^2}{a^2} + \frac{y^2}{b^2} + \frac{2xy}{ab} = 0$$

$$\left(\frac{x}{a} + \frac{y}{b}\right) = 0$$

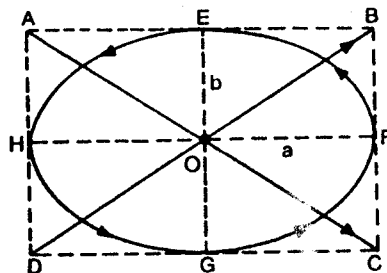

Fig. 7.9

$$y = -\left(\frac{b}{a}\right)x \quad \dots(vi)$$

This represents equation of a straight line  $AC$  (Fig. 7.9).

(iii) If  $\alpha = \frac{\pi}{2}$  or  $\frac{3\pi}{2}$ ;  $\sin \alpha = 1$ ;

$$\cos \alpha = 0$$

$$\therefore \frac{x^2}{a^2} + \frac{y^2}{b^2} = 1$$

This represents the equation of an ellipse  $EHGF$  (Fig. 7.9) with  $a$  and  $b$  as the semi-major and semi-minor axes.

(iv) If  $\alpha = \frac{\pi}{2}$  or  $\frac{3\pi}{2}$

$$a = b$$

and

$$\frac{x^2}{a^2} + \frac{y^2}{b^2} = 1$$

then

$$x^2 + y^2 = a^2$$

or

This represents the equation of a circle of radius  $a$  (Fig. 7.10).

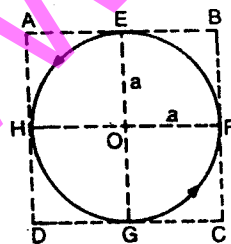

Fig. 7.10

(a) If  $\alpha = \frac{\pi}{4}$  or  $\frac{7\pi}{4}$  the resultant vibration is an oblique ellipse

$KLMN$  as shown in Fig. 7.11 (i)

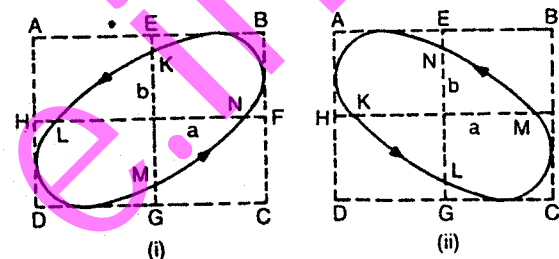

Fig. 7.11

On the other hand if  $\alpha = \frac{3\pi}{4}$  or  $\frac{5\pi}{4}$ , the resultant vibration is again an oblique ellipse  $KLMN$  is shown in Fig. 7.11 (ii). The cycle of changes is repeated after every time period.

### 7.12 HUYGENS PRINCIPLE

According to Huygens, a source of light sends out waves in all directions, through a hypothetical medium called ether. In Fig. 7.12 (i),  $S$

is a source of light sending light energy in the form of waves in all directions. After any given interval of time ( $t$ ), all the particles of the medium on the surface  $XY$  will be vibrating in phase. Thus,  $XY$  is a portion of the sphere of radius  $vt$  and centre  $S$ .  $v$  is the velocity of propagation of the wave.  $XY$  is called the primary wavefront. A wavefront can be defined as the locus of all the points of the medium which are vibrating in phase and are also displaced at the

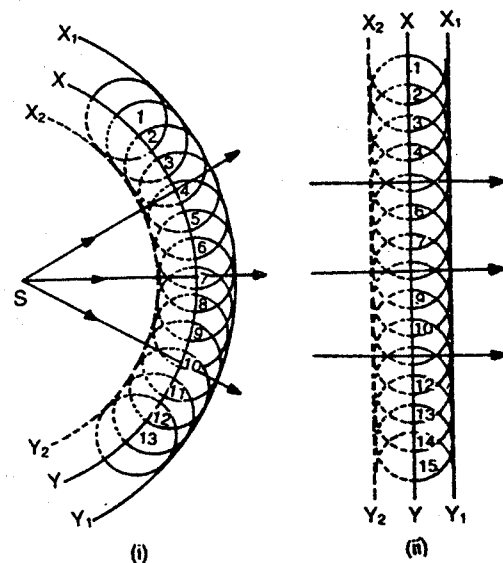

Fig. 7.12

same time. If the distance of the source is small [Fig. 7.12 (i)] the wavefront is spherical. When the source is at a large distance, then any small portion of the wavefront can be considered plane [Fig. 7.12 (ii)]. Thus rays of light diverging from or converging to a point give rise to a spherical wavefront and a parallel beam of light gives rise to a plane wave front

According to Huygens principle, all points on the primary wavefront (1, 2, 3 etc., Fig. 7.12) are sources of secondary disturbance. These secondary waves travel through space with the same velocity as the original wave and the envelope of all the secondary wavelets after any given interval of time gives rise to the secondary wavefront. In Fig. 7.12 (i),  $XY$  is the primary spherical wavefront and in Fig. 7.12 (ii)  $XY$  is the primary plane wavefront. After an interval of time  $t$ , the secondary waves travel a distance  $vt$ . With the points 1, 2, 3 etc. as centres, draw spheres of radii  $vt$ . The surfaces  $X_1Y_1$  and  $X_2Y_2$  refer to the secondary wavefront.  $X_1Y_1$  is the forward wavefront and  $X_2Y_2$  is the backward wavefront. But according to Huygens principle, the secondary wavefront is confined only to the forward wavefront  $X_1Y_1$  and not the backward wavefront  $X_2Y_2$ . However, no explanation to the absence of backward wavefront was given by Huygens.

### 7.13 REFLECTION OF A PLANE WAVE FRONT AT A PLANE SURFACE

Let  $XY$  be a plane reflecting surface and  $AMB$  the incident plane wavefront. All the particles on  $AB$  will be vibrating in phase. Let  $i$  be the angle of incidence (Fig. 7.13).

In the time the disturbance at  $A$  reaches  $C$ , the secondary waves from the point  $B$  must have travelled a distance  $BD$  equal to  $AC$ . With the point  $B$  as centre and radius equal to  $AC$  construct a sphere. From the point  $C$ , draw tangents  $CD$  and  $CD'$ . Then  $BD = BD'$ .

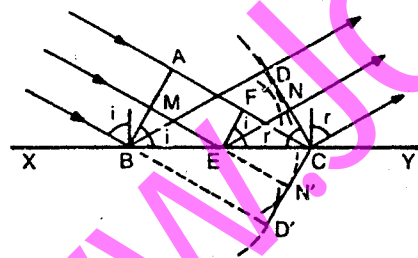

Fig. 7.13

In the  $\Delta$ s  $BAC$  and  $BDC$

$BC$  is common

$$BD = AC$$

and

$$\angle BAC = \angle BDC = 90^\circ$$

$\therefore$  The two triangles are congruent,

$$\therefore \angle ABC = i = \angle BCD = r.$$

$$\therefore i = r$$

Thus, the angle of incidence is equal to the angle of reflection. Hence,  $CD$  forms the reflected plane wavefront. It can be shown that all the points on  $CD$  form the reflected plane wavefront. In the time the disturbance from  $F$  reaches the point  $C$ , the secondary waves from  $E$  must have travelled a distance  $EN = FC$ . With  $E$  as centre and radius  $FC$  draw a sphere and draw tangents  $CN$  and  $CN'$  to the sphere. It can be shown that the triangles  $EFC$  and  $ENC$  are congruent.

$$AC = AF + FC$$

But  $AF = ME$

and  $FC = EN$

$$\therefore AC = ME + EN$$

Thus, all the secondary waves from different points on  $AB$  reach the corresponding points on  $CD$  at the same time. Therefore,  $CD$  forms the reflected plane wavefront and also the angle of incidence is equal to the angle of reflection.

### 7.14 REFLECTION OF A PLANE WAVEFRONT AT A SPHERICAL SURFACE

Let  $APB$  be a convex reflecting surface and  $QPR$  the incident plane wavefront (Fig. 7.14). By the time the disturbance at  $Q$  and  $R$  reaches the points  $A$  and  $B$  on the reflecting surface, the secondary waves from  $P$  must have travelled a distance  $PK$  back into the same medium such that  $QA = RB = PL = PK$ .

Then  $AKB$  forms the reflected spherical wavefront whose centre of curvature is  $F$ . Similarly, the secondary waves corresponding to the points lying on the incident wavefront  $QPR$  will reach the surface  $AKB$  in the same time after reflection.  $F$  is called the focus of the spherical mirror  $APB$ .  $PF$  is the focal length of the mirror.

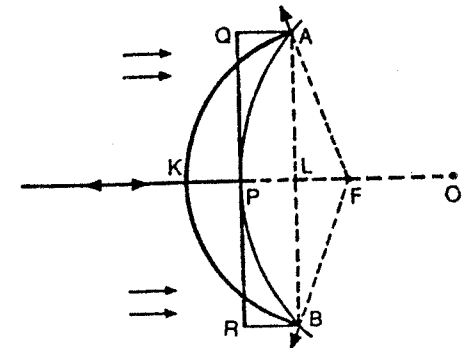
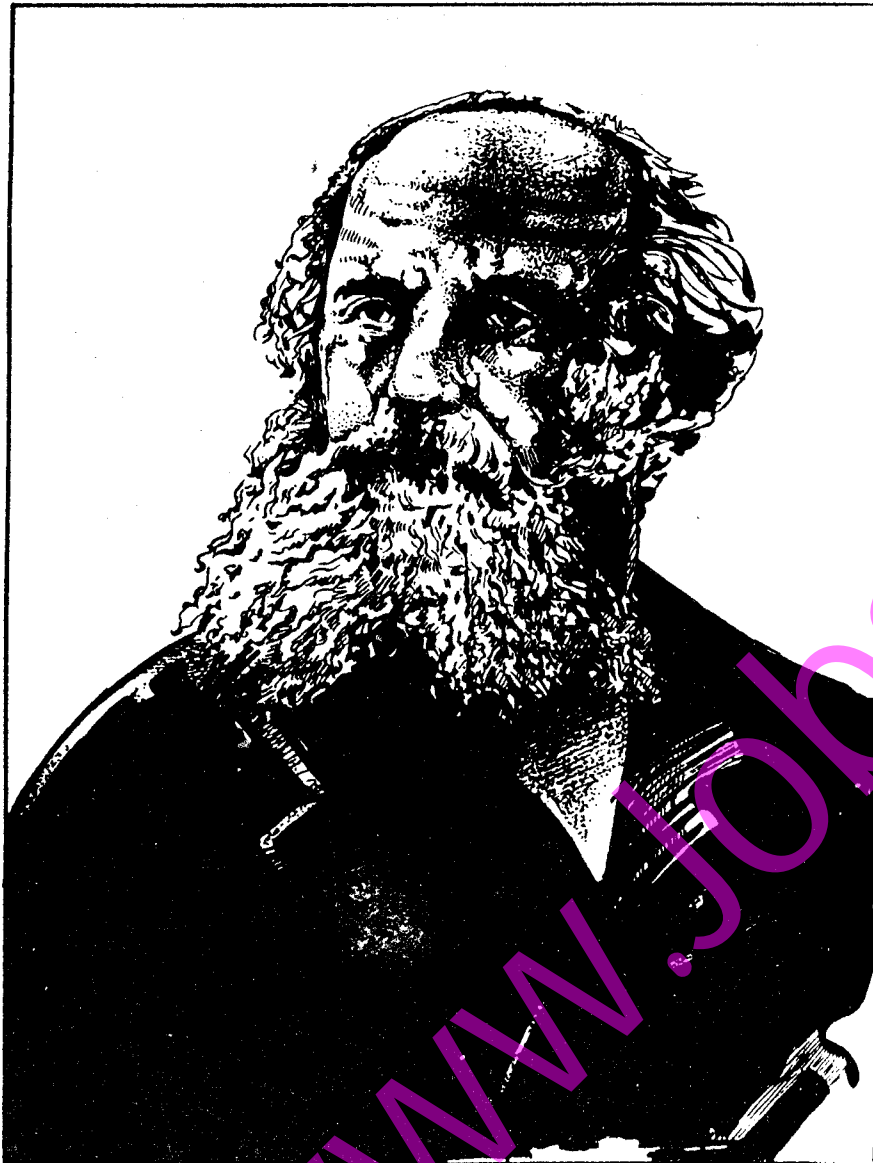

Fig. 7.14

In Fig. 7.14,  $APB$  is a small arc of a circle of radius  $PO = R$  and  $ALB$  is a chord.  $PL$  is called the sagitta of the arc. From geometry,

$$AL^2 = PL(2R - PL)$$

$$= 2R.PL - PL^2$$



**JAMES CLERK MAXWELL (1831-1879)**

He did fundamental work in colour vision and colour photography. He is well known for the discovery of the Electromagnetic Theory of Light

$$\therefore \mu AC = LP + \mu PQ + QN$$

$$\text{But, } AC = KM \text{ (approximately)}$$

$$\therefore \mu KM = LP + \mu PQ + QN$$

$$\mu [KP + PQ + QM] = LP + \mu PQ + QN$$

$$\text{or } \mu [KP + QM] = (KP - KL) + (QM + MN) \quad \dots(i)$$

$$\text{Here } AL = CM = h \text{ (approximately)}$$

$$\therefore KP = \frac{h^2}{2R_1}; \quad QM = \frac{h^2}{2R_2}$$

$$KL = \frac{h^2}{2u} \text{ and } MN = \frac{h^2}{2v}$$

Substituting these values in equation (i)

$$\mu \left[ \frac{h^2}{2R_1} + \frac{h^2}{2R_2} \right] = \frac{h^2}{2R_1} - \frac{h^2}{2u} + \frac{h^2}{2R_2} + \frac{h^2}{2v}$$

$$\mu \left[ \frac{1}{R_1} + \frac{1}{R_2} \right] = \left( \frac{1}{R_1} + \frac{1}{R_2} \right) + \left( \frac{1}{v} - \frac{1}{u} \right)$$

$$\text{or } \frac{1}{v} - \frac{1}{u} = (\mu - 1) \left[ \frac{1}{R_1} + \frac{1}{R_2} \right]$$

According to the convention of signs,  $u$  is  $-ve$ ,  $v$  is  $-ve$ ,  $R_1$  is  $-ve$  and  $R_2$  is  $+ve$

$$\therefore -\frac{1}{v} + \frac{1}{u} = (\mu - 1) \left( -\frac{1}{R_1} + \frac{1}{R_2} \right)$$

$$\text{or } \frac{1}{v} - \frac{1}{u} = (\mu - 1) \left( \frac{1}{R_1} - \frac{1}{R_2} \right) \quad \dots(ii)$$

$$\text{If } u = \infty, v = f$$

$$\therefore \frac{1}{f} = (\mu - 1) \left( \frac{1}{R_1} - \frac{1}{R_2} \right) \quad \dots(iii)$$

## 7.22 NATURE OF LIGHT

(i) **Corpuscular theory.** Rectilinear propagation of light is a natural deduction on the basis of corpuscular theory. This theory can also explain reflection and refraction, though the theory does not clearly envisage why, how and when the force of attraction or repulsion is experienced perpendicular to the reflecting or refracting surface by a corpuscle. Newton assumed that the corpuscles possess fits which allow them easy reflection at one stage and easy transmission at the other. According to Newton's

corpuscular theory the velocity of light in a denser medium is higher than the velocity in a rarer medium. But the experimental results of Foucault and Michelson show that the velocity of light in a rarer medium is higher than that in a denser medium. Interference could not be explained on the basis of corpuscular theory because two material particles cannot cancel one another's effect. The phenomenon of diffraction *viz.*, bending of light round corners or illumination of geometrical shadow cannot be conceived according to corpuscular theory, because a corpuscle travelling at high speed will not be deviated from its straight line path. Certain crystals like quartz, calcite etc. exhibit the phenomenon of double refraction. Explanation of this has not been possible with the corpuscle concept. The unsymmetrical behaviour of light about the axis of propagation (*viz.* polarization of light) cannot be accounted for by the corpuscular theory.

(ii) **Wave theory.** Huygens wave theory could explain satisfactorily the phenomena of reflection and refraction. Applying the principle of secondary wave points, rectilinear propagation of light can be correlated. The phenomenon of interference can also be understood considering that light energy is propagated in the form of waves. Two wave trains of equal frequency and amplitude and differing in phase can annul one another's effect and produce darkness. Similar to sound waves, bending of waves round obstacles is possible, thus enabling the understanding of the phenomenon of diffraction. Double refraction can also be explained on the basis of wave theory. According to Huygens, propagation of light is in the form of longitudinal waves. But in the case of longitudinal waves, one cannot expect the unsymmetrical behaviour of a beam of light about the axis of propagation. This difficulty was overcome when Fresnel suggested that the light waves are transverse and not longitudinal. On the basis of this concept, the phenomenon of polarization can also be understood. Finally, on the basis of wave theory it can be shown mathematically, that the velocity of light in a rarer medium is higher than the velocity of light in a denser medium. This is in accordance with the experimental results on the velocity of light.

(iii) **Conclusion.** The controversy between the corpuscular theory and the wave theory existed till about the end of the eighteenth century. At one time the corpuscular theory held the ground and at another time the wave theory was accepted, the discovery of the phenomenon of interference by Thomas Young in 1800, the experimental results of Foucault and Michelson on the velocity on light in different media and the revolutionary hypothesis of Fresnel in 1816 that the vibration of the ether particles is transverse and not longitudinal gave, in a way, a solid ground to the wave theory.

The next important advance in the nature of light was due to the work of Clerk Maxwell. Maxwell's electromagnetic theory of light lends support to Huygens wave theory whereas quantum theory strengthens the

particle concept. It is very interesting to note, that light is regarded as a wave motion at one time and as a particle phenomenon at another time.

### EXERCISES VII

1. What is Huygens principle in regard to the conception of light waves? Using Huygens conception show that  $\mu$  is equal to the ratio of wave velocities in the two media.
2. Obtain an expression for refraction of a spherical wave at a spherical surface.
3. State Huygens principle for the propagation of light. Using the same, deduce the formula connecting object and image distances with the constants of a thin lens.
4. Explain how the phenomena of reflection and refraction of light are accounted for on the wave theory and point out the physical significance of refractive index. (Mysore 1991)
5. What is a wavefront? How is it produced? Derive the lens formula for a thin lens on the basis of the wave theory of light.
6. Write a short note on the wave theory of light. How is refraction explained on this theory? (Delhi 1992)
7. Explain Huygens principle. Derive the refraction formula for a thin lens on the basis of wave theory. (Agra 1992)
8. Write a short discussion on the nature of light. Deduce with the help of Huygens wave theory of light, an expression for the focal length of a thin lens in terms of the radii of curvature of its two surfaces and the refractive index of the material of which it is made. (Rajasthan 1991)
9. Write short notes on :
  - (i) Wave theory of light. (Punjab 1985)
  - (ii) Huygens principle. [Delhi (Hons.) 1993]
  - (iii) Newton's corpuscular theory.
10. Show how the wave theory and the corpuscular theory of light account for (a) refraction and (b) total internal reflection of light. How was the issue decided in favour of the wave theory? (Rajasthan 1990)
11. Discuss the nature of light. How do you explain the phenomenon of reflection, refraction and rectilinear propagation of light on the basis of wave theory? (Mysore 1990 ; Rajasthan 1986)
12. Write an essay on the nature of light. (Agra 1986)
13. What is Huygens principle? Obtain the laws of reflection and refraction on the basis of wave theory of light. (Gorakhpur 1987)



14. Apply Huygens principle to derive the relation

$$\frac{1}{f} = (\mu - 1) \left( \frac{1}{R_1} - \frac{1}{R_2} \right)$$

for a thin lens.

(Mysore 1990)

15. State and explain Huygens principle of secondary waves. Apply this principle for explaining the simultaneous reflection and refraction of a plane light wave from a plane surface of separation of two optical media.

[Delhi 1984 ; Delhi (Hons.) 1984]

16. Explain Huygens principle of wave propagation and apply it to prove the laws of reflection of a plane wave at a plane surface.

[Delhi B.Sc.(Hons.) 1991]

17. State the principle of superposition. Give the mathematical theory of interference between two waves of amplitude  $a_1$  and  $a_2$  with phase difference  $\phi$ . Discuss some typical cases.

[Rajasthan 1985]

18. Deduce the laws of reflection with the help of Huygens theory of secondary wavelets.

(Rajasthan 1985)

19. What is Huygens principle ? How would you explain the phenomenon of reflection and refraction of plane waves at plane surfaces on the basis of wave nature of light ?

[Delhi (Sub.) 1986]

20. State and explain Huygens principle of secondary waves.

(Delhi 1988)

21. State and explain Huygens principle of secondary waves.

[Delhi ; 1992]

## INTERFERENCE

### 8.1 INTRODUCTION

The phenomenon of interference of light has proved the validity of the wave theory of light. Thomas Young successfully demonstrated his experiment on interference of light in 1802. When two or more wave trains act simultaneously on any particle in a medium, the displacement

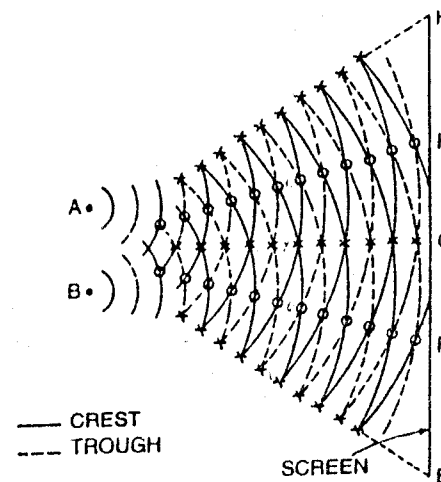

Fig. 8.1

of the particle at any instant is due to the superposition of all the wave trains. Also, after the superposition, at the region of cross over, the wave trains emerge as if they have not interfered at all. Each wave train retains its individual characteristics. Each wave train behaves as if others are absent. This principle was explained by Huygens in 1678.

The phenomenon of interference of light is due to the superposition of two trains within the region of cross over. Let us consider the waves produced on the surface of water. In Fig. 8.1 points  $A$  and  $B$  are the two sources which produce waves of equal amplitude and constant phase difference. Waves spread out on the surface of water which are circular in shape. At any instant, the particle will be under the action of the displacement due to both the waves. The points shown by circles in the diagram will have minimum displacement because the crest of one wave falls on the trough of the other and the resultant displacement is zero. The points shown by crosses in the diagram will have maximum displacement because, either the crest of one will combine with the crest of the other or the trough of one will combine with the trough of the other. In such a case, the amplitude of the displacement is twice the amplitude of either of the waves. Therefore, at these points the waves reinforce with each other. As the intensity (energy) is directly proportional to the square of the amplitude ( $I \propto A^2$ ) the intensity at these points is four times the intensity due to one wave. It should be remembered that there is no loss of energy due to interference. The energy is only transferred from the points of minimum displacement to the points of maximum displacement.

## 8.2 YOUNG'S EXPERIMENT

In the year 1802, Young demonstrated the experiment on the interference of light. He allowed sunlight to fall on a pinhole  $S$  and then at some distance away on two pinholes  $A$  and  $B$  (Fig. 8.2).

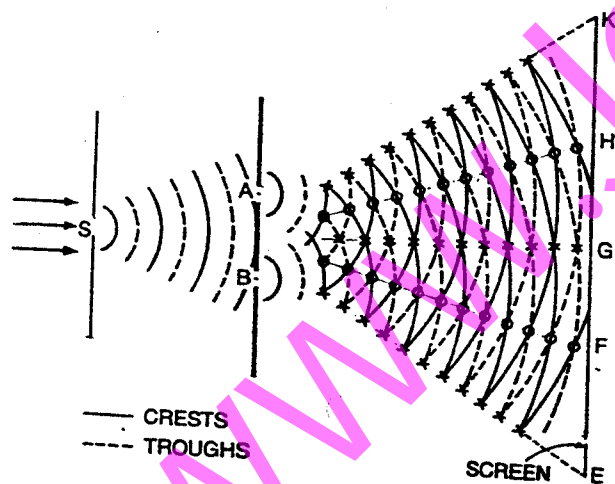

Fig. 8.2

$A$  and  $B$  are equidistant from  $S$  and are close to each other. Spherical waves spread out from  $S$ . Spherical waves also spread out from  $A$  and  $B$ . These waves are of the same amplitude and wavelength. On the screen interference bands are produced which are alternatively dark and bright. The points such as  $E$  are bright because the crest due to one wave coincides with the crest due to the other and therefore they reinforce with each other. The points such as  $F$  are dark because the crest of one falls on the trough of the other and they neutralize the effect of each other. Points, similar to  $E$ , where the trough of one falls on the trough of the other, are also bright because the two waves reinforce.

It is not possible to show interference due to two independent sources of light, because a large number of difficulties are involved. The two sources may emit light waves of largely different amplitude and wavelength and the phase difference between the two may change with time.

## 8.3 COHERENT SOURCES

Two sources are said to be coherent if they emit light waves of the same frequency, nearly the same amplitude and are always in phase with each other. It means that the two sources must emit radiations of the same colour (wavelength). In actual practice it is not possible to have two independent sources which are coherent. But for experimental purposes, two virtual sources formed from a single source can act as coherent sources. Methods have been devised where (i) interference of light takes place between the waves from the real source and a virtual source (ii) interference of light takes place between waves from two sources formed due to a single source. In all such cases, the two sources will act, as if they are perfectly similar in all respects.

Since the wavelength of light waves is extremely small (of the order of  $10^{-5}$  cm), the two sources must be narrow and must also be close to each other. Maximum intensity is observed at a point where the phase difference between the two waves reaching the point is a whole number multiple of  $2\pi$  or the path difference between the two waves is a whole number multiple of wavelength. For minimum intensity at a point, the phase difference between the two waves reaching the point should be an odd number multiple of  $\pi$  or the path difference between the two waves should be an odd number multiple of half wavelength.

## 8.4 PHASE DIFFERENCE AND PATH DIFFERENCE

If the path difference between the two waves is  $\lambda$ , the phase difference =  $2\pi$ .

Suppose for a path difference  $x$ , the phase difference is  $\delta$

For a path difference  $\lambda$ , the phase difference =  $2\pi$

∴ For a path difference  $x$ , the phase difference =  $\frac{2\pi x}{\lambda}$

$$\text{Phase difference } \delta = \frac{2\pi x}{\lambda} = \frac{2\pi}{\lambda} \times (\text{path difference})$$

### ANALYTICAL TREATMENT OF INTERFERENCE

Consider a monochromatic source of light  $S$  emitting waves of wavelength  $\lambda$  and two narrow pinholes  $A$  and  $B$  (Fig. 8.3).  $A$  and  $B$  are equidistant from  $S$  and act as two virtual coherent sources. Let  $a$  be the amplitude of the waves. The phase difference between the two waves reaching the point  $P$ , at any instant, is  $\delta$ .

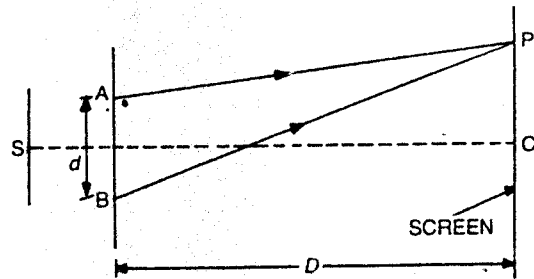

Fig. 8.3

If  $y_1$  and  $y_2$  are the displacements

$$y_1 = a \sin \omega t$$

$$y_2 = a \sin (\omega t + \delta)$$

$$\therefore y = y_1 + y_2 = a \sin \omega t + a \sin (\omega t + \delta)$$

$$y = a \sin \omega t + a \sin \omega t \cos \delta + a \cos \omega t \sin \delta$$

$$= a \sin \omega t (1 + \cos \delta) + a \cos \omega t \sin \delta.$$

$$\text{Taking } a(1 + \cos \delta) = R \cos \theta \quad \dots(i)$$

$$\text{and } a \sin \delta = R \sin \theta \quad \dots(ii)$$

$$y = R \sin \omega t \cos \theta + R \cos \omega t \sin \theta$$

$$y = R \sin (\omega t + \theta) \quad \dots(iii)$$

which represents the equation of simple harmonic vibration of amplitude  $R$ .

Squaring (i) and (ii) and adding,

$$R^2 \sin^2 \theta + R^2 \cos^2 \theta = a^2 \sin^2 \delta + a^2 (1 + \cos \delta)^2$$

$$\text{or } R^2 = a^2 \sin^2 \delta + a^2 (1 + \cos^2 \delta + 2 \cos \delta)$$

$$R^2 = a^2 \sin^2 \delta + a^2 + a^2 \cos^2 \delta + 2 a^2 \cos \delta$$

$$= 2a^2 + 2a^2 \cos \delta = 2a^2 (1 + \cos \delta)$$

$$R^2 = 2a^2 \cdot 2 \cos^2 \frac{\delta}{2} = 4a^2 \cos^2 \frac{\delta}{2}$$

The intensity at a point is given by the square of the amplitude

$$\therefore I = R^2$$

$$\text{or } I = 4a^2 \cos^2 \frac{\delta}{2} \quad \dots(iv)$$

**Special cases :** (i) When the phase difference  $\delta = 0, 2\pi, 2(2\pi), \dots, n(2\pi)$ , or the path difference  $x = 0, \lambda, 2\lambda, \dots, n\lambda$ .

$$I = 4a^2$$

Intensity is maximum when the phase difference is a whole number multiple of  $2\pi$  or the path difference is a whole number multiple of wavelength.

(ii) When the phase difference,  $\delta = \pi, 3\pi, \dots, (2n + 1)\pi$ , or the path difference  $x = \frac{\lambda}{2}, \frac{3\lambda}{2}, \frac{5\lambda}{2}, \dots, (2n + 1)\frac{\lambda}{2}$ ,

$$I = 0$$

Intensity is minimum when the path difference is an odd number multiple of half wavelength.

**Energy distribution.** From equation (iv), it is found that the intensity at bright points is  $4a^2$  and at dark points it is zero. According to

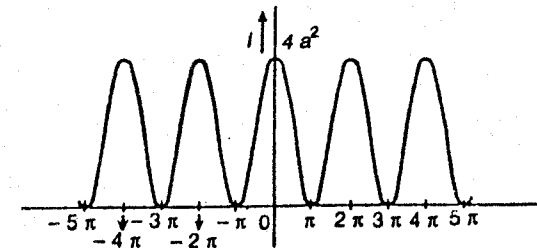

Fig. 8.4

the law of conservation of energy, the energy cannot be destroyed. Here also the energy is not destroyed but only transferred from the points of minimum intensity to the points of maximum intensity. For, at bright

points, the intensity due to the two waves should be  $2a^2$  but actually it is  $4a^2$ . As shown in Fig. 8.4 the intensity varies from 0 to  $4a^2$ , and the average is still  $2a^2$ . It is equal to the uniform intensity  $2a^2$  which will be present in the absence of the interference phenomenon due to the two waves. Therefore, the formation of interference fringes is in accordance with the law of conservation of energy.

### 8.6 THEORY OF INTERFERENCE FRINGES

Consider a narrow monochromatic source  $S$  and two pinholes  $A$  and  $B$ , equidistant from  $S$ .  $A$  and  $B$  act as two coherent sources separated by a distance  $d$ . Let a screen be placed at a distance  $D$  from the coherent

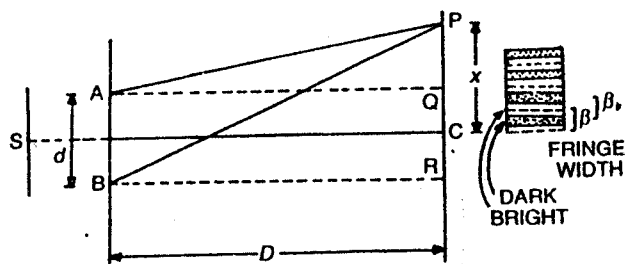

Fig. 8.5

sources. The point  $C$  on the screen is equidistant from  $A$  and  $B$ . Therefore, the path difference between the two waves is zero. Thus, the point  $C$  has maximum intensity.

Consider a point  $P$  at a distance  $x$  from  $C$ . The waves reach at the point  $P$  from  $A$  and  $B$ .

$$\text{Here, } PQ = x - \frac{d}{2}, \quad PR = x + \frac{d}{2}$$

$$(BP)^2 - (AP)^2 = \left[ D^2 + \left( x + \frac{d}{2} \right)^2 \right] - \left[ D^2 + \left( x - \frac{d}{2} \right)^2 \right]$$

$$(BP)^2 - (AP)^2 = 2xd$$

$$BP - AP = \frac{2xd}{BP + AP}$$

$$\text{But } BP = AP = D \quad (\text{approximately})$$

$$\therefore \text{ Path difference} = BP - AP = \frac{2xd}{2D} = \frac{xd}{D} \quad \dots(i)$$

$$\text{Phase difference} = \frac{2\pi}{\lambda} \left( \frac{xd}{D} \right) \quad \dots(ii)$$

(i) **Bright fringes.** If the path difference is a whole number multiple of wavelength  $\lambda$ , the point  $P$  is bright.

$$\therefore \frac{xd}{D} = n\lambda$$

$$\text{where } n = 0, 1, 2, 3, \dots$$

$$\text{or } x = \frac{n\lambda D}{d} \quad \dots(iii)$$

This equation gives the distances of the bright fringes from the point  $C$ . At  $C$ , the path difference is zero and a bright fringe is formed.

$$\begin{aligned} \text{When } n = 1, \quad x_1 &= \frac{\lambda D}{d} \\ n = 2, \quad x_2 &= \frac{2\lambda D}{d} \\ n = 3, \quad x_3 &= \frac{3\lambda D}{d} \\ x_n &= \frac{n\lambda D}{d} \end{aligned}$$

Therefore the distance between any two consecutive bright fringes

$$x_2 - x_1 = \frac{2\lambda D}{d} - \frac{\lambda D}{d} = \frac{\lambda D}{d} \quad \dots(iv)$$

(ii) **Dark fringes.** If the path difference is an odd number multiple of half wavelength, the point  $P$  is dark.

$$\frac{xd}{D} = (2n+1) \frac{\lambda}{2} \quad \text{where } n = 0, 1, 2, 3, \dots$$

$$\text{or } x = \frac{(2n+1)\lambda D}{2d} \quad \dots(v)$$

This equation gives the distances of the dark fringes from the point  $C$ .

$$\text{When, } n = 0, \quad x_0 = \frac{\lambda D}{2d}$$

$$n = 1, \quad x_1 = \frac{3\lambda D}{2d}$$

$$n = 2, \quad x_2 = \frac{5\lambda D}{2d}$$

$$\text{and } x_n = \frac{(2n+1)\lambda D}{2d}$$

The distance between any two consecutive dark fringes,

$$x_2 - x_1 = \frac{5\lambda D}{2d} - \frac{3\lambda D}{2d} = \frac{\lambda D}{d} \quad \dots(vi)$$

The distance between any two consecutive bright or dark fringes is known as fringe width. Therefore, alternately bright and dark parallel fringes are formed. The fringes are formed on both sides of  $C$ . Moreover, from equations (v) and (vi), it is clear that the width of the bright fringe is equal to the width of the dark fringe. All the fringes are equal in width and are independent of the order of the fringe. The breadth of a bright or a dark fringe is, however, equal to half the fringe width and is equal to  $\frac{\lambda D}{2d}$ . The fringe width  $\beta = \frac{\lambda D}{d}$ .

Therefore, (i) the width of the fringe is directly proportional to the wavelength of light,  $\beta \propto \lambda$ . (ii) The width of the fringe is directly proportional to the distance of the screen from the two sources,  $\beta \propto D$ . (iii) the width of the fringe is inversely proportional to the distance between the two sources,  $\beta \propto \frac{1}{d}$ . Thus, the width of the fringe increases (a) with increase in wavelength (b) with increase in the distance  $D$  and (c) by bringing the two sources  $A$  and  $B$  close to each other.

**Example 8.1.** Green light of wavelength  $5100 \text{ \AA}$  from a narrow slit is incident on a double slit. If the overall separation of 10 fringes on a screen 200 cm away is 2 cm. find the slit separation.

[Delhi B.Sc. (Hons.)]

$$\beta = \frac{\lambda D}{d}$$

Here

$$\lambda = 5100 \times 10^{-8} \text{ cm}, \quad d = ?$$

$$D = 200 \text{ cm}$$

$$10\beta = 2 \text{ cm}$$

or

$$\beta = 0.2 \text{ cm}$$

$$d = \frac{\lambda D}{\beta}$$

$$d = \frac{5100 \times 10^{-8} \times 200}{0.2}$$

$$d = 0.051 \text{ cm}$$

**Example 8.2.** Two coherent sources are 0.18 mm apart and the fringes are observed on a screen 80 cm away. It is found that with a certain monochromatic source of light, the fourth bright fringe is situated at a distance of 10.8 mm from the central fringe. Calculate the wavelength of light.

$$\text{Here, } D = 80 \text{ cm}, \quad d = 0.18 \text{ mm} = 0.018 \text{ cm}$$

$$n = 4, \quad x = 10.8 \text{ mm} = 1.08 \text{ cm}, \quad \lambda = ?$$

$$x = \frac{n\lambda D}{d}$$

$$\text{or } \lambda = \frac{xd}{nD} = \frac{1.08 \times 0.018}{4 \times 80} = 6075 \times 10^{-8} \text{ cm} \\ = 6075 \text{ \AA}$$

**Example 8.3.** In Young's double slit experiment the separation of the slits is 1.9 mm and the fringe spacing is 0.31 mm at a distance of 1 metre from the slits. Calculate the wavelength of light.

Here

$$\beta = 0.31 \text{ mm} = 0.031 \text{ cm}$$

$$d = 1.9 \text{ mm} = 0.19 \text{ cm}$$

$$D = 1 \text{ m} = 100 \text{ cm}$$

$$\beta = \frac{\lambda D}{d}$$

$$\text{or } \lambda = \frac{\beta d}{D}$$

$$\lambda = \frac{0.031 \times 0.19}{100}$$

$$\lambda = 5890 \times 10^{-8} \text{ cm} = 5890 \text{ \AA}$$

**Example 8.4.** Two straight and narrow parallel slits 1 mm apart are illuminated by monochromatic light. Fringes formed on the screen held at a distance of 100 cm from the slits are 0.50 mm apart. What is the wavelength of light? [Delhi 1977]

Here

$$\beta = 0.50 \text{ mm} = 0.05 \text{ cm}$$

$$d = 1 \text{ mm} = 0.1 \text{ cm}$$

$$D = 100 \text{ cm}$$

$$\beta = \frac{\lambda D}{d}$$

or

$$\lambda = \frac{\beta d}{D}$$

$$\lambda = \frac{0.05 \times 0.1}{100}$$

$$\lambda = 5 \times 10^{-5} \text{ cm}$$

$$\lambda = 5000 \text{ \AA}$$

**Example 8.5.** A Young's double slit experiment is arranged such that the distance between the centers of the two slits is  $d$  and the source slit, emitting light of wavelength  $\lambda$ , is placed at a distance  $x$  from the double slit. If now the source slit is gradually opened up, for what width will the fringes first disappear? [Delhi (Hons) 1992]

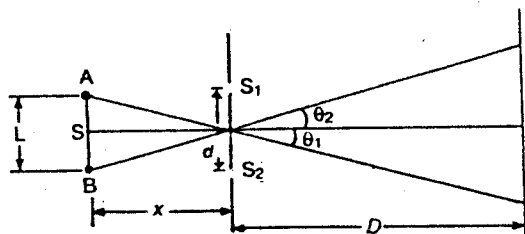

Fig. 8.6

A and B are two extreme points of the source S separated by distance  $L$ .

Here  $\theta_1 = -\left(\frac{L}{2x}\right)$  when  $x \gg L$

$$\theta_2 = \left(\frac{L}{2x}\right)$$

The fringe pattern first disappears when the central maximum of one pattern overlaps on the first minimum of the second pattern. The first minimum occurs at a distance given by

$$y = \pm \frac{\lambda D}{2d}$$

Also  $\frac{y}{D} = \theta = \pm \frac{\lambda}{2d}$

For source A, these minima occur at an angle

$$\theta_1 \pm \frac{\lambda}{2d}$$

The fringe width is very large when  $d$  is very small. As  $d$  increases, the first minimum of  $S_1$  moves towards the zeroth maximum of  $S_2$ . These two meet when  $d = d_0$ .

Here  $\theta_2 = \theta_1 + \frac{\lambda}{2d_0}$

or  $\frac{L}{2x} = -\frac{L}{2x} + \frac{\lambda}{2d_0}$

$$d_0 = \left(\frac{\lambda x}{2L}\right)$$

$$\therefore L = \left[\frac{\lambda x}{2d_0}\right]$$

**Example 8.6.** A light source emits light of two wavelengths  $\lambda_1 = 4300 \text{ \AA}$  and  $\lambda_2 = 5100 \text{ \AA}$ . The source is used in a double slit interference experiment. The distance between the sources and the screen is 1.5 m and the distance between the slits is 0.025 mm. Calculate the separation between the third order bright fringes due to these two wavelengths.

Here

$$D = 1.5 \text{ m}$$

$$d = 0.025 \text{ mm} = 25 \times 10^{-6} \text{ m}$$

$$\lambda_1 = 4300 \text{ \AA} = 4.3 \times 10^{-7} \text{ m}$$

$$\lambda_2 = 5100 \text{ \AA} = 5.1 \times 10^{-7} \text{ m}$$

$$n = 3$$

$$x_1 = \frac{n \lambda_1 D}{d}$$

$$x_2 = \frac{n \lambda_2 D}{d}$$

$$x_2 - x_1 = \left(\frac{n \lambda_2 D}{d}\right) - \left(\frac{n \lambda_1 D}{d}\right)$$

$$= \frac{nD}{d} [\lambda_2 - \lambda_1]$$

$$= \left(\frac{3 \times 1.5}{25 \times 10^{-6}}\right) [5.1 \times 10^{-7} - 4.3 \times 10^{-7}]$$

$$= 0.0144 \text{ m}$$

$$= 1.44 \text{ cm}$$

Hence, the separation between the two fringes is 1.44 cm.

**Example 8.7.** Two coherent sources of monochromatic light of wavelength  $6000 \text{ \AA}$  produce an interference pattern on a screen kept at a distance of 1 m from them. The distance between two consecutive bright fringes on the screen is 0.5 mm. Find the distance between the two coherent sources. [IAS]

Here

$$\lambda = 6000 \text{ \AA} = 6 \times 10^{-7} \text{ m}$$

$$D = 1 \text{ m}$$

$$\beta = 0.5 \text{ mm} = 5 \times 10^{-4} \text{ m}$$

$$d = ?$$

$$\beta = \frac{\lambda D}{d}$$

$$d = \frac{\lambda D}{\beta}$$

$$d = \frac{6 \times 10^{-7} \times 1}{5 \times 10^{-4}}$$

$$d = 1.2 \times 10^{-3} \text{ m}$$

$$d = 1.2 \text{ mm}$$

**Example 8.8.** Light of wavelength  $5500 \text{ \AA}$  from a narrow slit is incident on a double slit. The overall separation of 5 fringes on a screen  $200 \text{ cm}$  away is  $1 \text{ cm}$ , calculate (a) the slit separation and (b) the fringe width.

Here

$$x = \frac{n \lambda D}{d}$$

$$n = 5$$

$$D = 200 \text{ cm} = 2 \text{ m}$$

$$\lambda = 5500 \text{ \AA} = 5.5 \times 10^{-7} \text{ m}$$

$$x = 1 \text{ cm} = 10^{-2} \text{ m}$$

$$d = ?$$

$$(a) \quad d = \frac{n \lambda D}{x}$$

$$d = \frac{5 \times 5.5 \times 10^{-7} \times 2}{10^{-2}}$$

$$d = 5.5 \times 10^{-4} \text{ m}$$

$$d = 0.055 \text{ cm}$$

$$(b) \quad \beta = \frac{x}{n}$$

$$\beta = \frac{1}{5} \text{ cm}$$

$$\beta = 0.2 \text{ cm}$$

## 8.7 FRESNEL'S MIRRORS

Fresnel produced the interference fringes by using two plane mirrors  $M_1$  and  $M_2$  arranged at an angle of nearly  $180^\circ$  so that their surfaces are nearly (not exactly) coplanar (Fig. 8.7).

A monochromatic source of light  $S$  is used. The pencil of light from  $S$  incident on the two mirrors, after reflection appears to come from two virtual sources  $A$  and  $B$  at some distance  $d$  apart. Therefore,  $A$  and  $B$  act

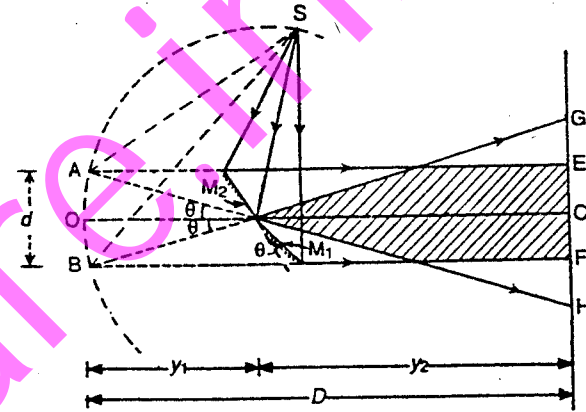

Fig. 8.7

as two virtual coherent sources and interference fringes are obtained on the screen. These fringes are of equal width and are alternately dark and bright.

**Theory.**  $A$  and  $B$  are two coherent sources at a distance  $d$  apart. The screen is at a distance  $D$  from the virtual sources. The two reflected beams from the mirrors  $M_1$  and  $M_2$  overlap between  $E$  and  $F$  (shown as shaded in the diagram) and interference fringes are formed.

(For complete theory read Article 8.6)

$$\text{Here, } D = Y_1 + Y_2$$

$$\text{Fringe width } \beta = \frac{\lambda D}{d}$$

A point on the screen will be at the centre of a bright fringe, if its distance from  $C$  is  $\frac{n \lambda D}{d}$  where  $n = 0, 1, 2, 3$  etc, and it will be at the centre of a dark fringe, if its distance from  $C$  is

$$\frac{(2n+1) \lambda D}{2d}$$

where  $n = 0, 1, 2, 3, \dots$  etc.

For the fringes to be formed, the following conditions must be satisfied. The two mirrors  $M_1$  and  $M_2$  should be made from optically flat glass and silvered on the front surfaces. No reflection should take place from

the back of the mirrors. The polishing should extend up to the line of intersection of the two mirrors and the line of intersection must be parallel to the line source (slit).

The distance between the two virtual sources  $A$  and  $B$  can be calculated as follows. Suppose the distance between the points of intersection of the mirrors and the source  $S$  is  $y_1$ .

$\theta$  is known. The angle of separation between  $A$  and  $B$  is  $2\theta$ .

$$\therefore d = 2\theta y_1$$

When white light is used the central fringe  $C$  is white whereas the other fringes on both sides of  $C$  are coloured because the fringe width ( $\beta$ ) depends upon the wavelength. Only the first few coloured fringes are observed and the other fringes overlap. Therefore, the number of fringes seen in the field of view with a monochromatic source of light are more, than with white light.

### 8.8 FRESNEL'S BIPRISM

Fresnel used a biprism to show interference phenomenon. The biprism  $abc$  consists of two acute angled prisms placed base to base. Actually, it is constructed as a single prism of obtuse angle of about  $179^\circ$  (Fig. 8.7A). The acute angle  $\alpha$  on both sides is about  $30'$ . The prism is placed with its refracting edge parallel to the line source  $S$  (slit) such that  $Sa$  is normal to the face  $bc$  of the prism. When light falls from  $S$  on the lower portion of the biprism it is bent upwards and appears to come from

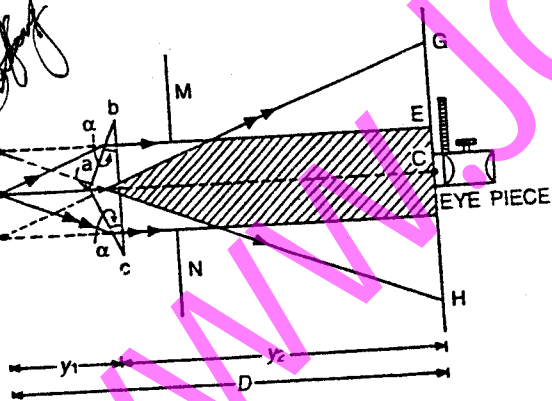

Fig. 8.7A

the virtual source  $B$ . Similarly light falling from  $S$  on the upper portion of the prism is bent downwards and appears to come from the virtual source  $A$ . Therefore  $A$  and  $B$  act as two coherent sources. Suppose the distance between  $A$  and  $B = d$ . If a screen is placed at  $C$ , interference

fringes of equal width are produced between  $E$  and  $F$  but beyond  $E$  and  $F$  fringes of large width are produced which are due to diffraction.  $MN$  is a stop to limit the rays. To observe the fringes, the screen can be replaced by an eye-piece or a low power microscope and fringes are seen in the field of view. If the point  $C$  is at the principal focus of the eyepiece, the fringes are observed in the field of view.

**Theory.** For complete theory refer to Article 8.6. The point  $C$  is equidistant from  $A$  and  $B$ . Therefore, it has maximum intensity. On both sides of  $C$ , alternately bright and dark fringes are produced. The width of the bright fringe or dark fringe,  $\beta = \frac{\lambda D}{d}$ . Moreover, any point on the screen will be at the centre of a bright fringe if its distance from  $C$  is  $\beta = \frac{n\lambda D}{d}$ , where  $n = 0, 1, 2, 3$  etc. The point will be at the centre of a dark fringe if its distance from  $C$  is

$$\frac{(2n+1)\lambda D}{2d}$$

where  $n = 0, 1, 2, 3$  etc.

**Determination of wavelength of light.** Fresnel's biprism can be used to determine the wavelength of a given source of monochromatic light.

A fine vertical slit  $S$  is adjusted just close to a source of light and the refracting edge is also set parallel to the slit  $S$  such that  $bc$  is horizontal

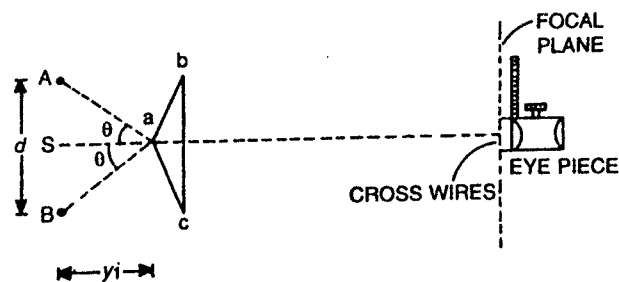

Fig. 8.8

(Fig. 8.8). They are adjusted on an optical bench. A micrometer eyepiece is placed on the optical bench at some distance from the prism to view the fringes in its focal plane (at its cross wires).

Suppose the distance between the source and the eyepiece =  $D$  and the distance between the two virtual sources  $A$  and  $B = d$ . The eyepiece is moved horizontally (perpendicular to the length of the bench) to determine the fringe width. Suppose, for crossing 20 bright fringes from the field of view, the eyepiece has moved through a distance  $l$ .



Then the fringe width,  $\beta = \frac{l}{20}$

But the fringe width  $\beta = \frac{\lambda D}{d}$

$$\therefore \lambda = \frac{\beta d}{D} \quad \dots(i)$$

In equation (i)  $\beta$  and  $D$  are known. If  $d$  is also known,  $\lambda$  can be calculated.

**Determination of the distance between the two virtual sources ( $d$ ).**  
For this purpose, we make use of the displacement method. A convex lens is placed between the biprism and the eyepiece in such a position, that the images of the virtual sources  $A$  and  $B$  are seen in the field of view of the eyepiece. Suppose the lens is in the position  $L_1$  (Fig. 8.9). Measure the distance between the images of  $A$  and  $B$  as seen in the eyepiece. Let it be  $d_1$ .

In this case,

$$\frac{d_1}{d} = \frac{v}{u} = \frac{n}{m} \quad \dots(ii)$$

Now move the lens towards the eyepiece and bring it to some other position  $L_2$ , so that again the images of  $A$  and  $B$  are seen clearly in the

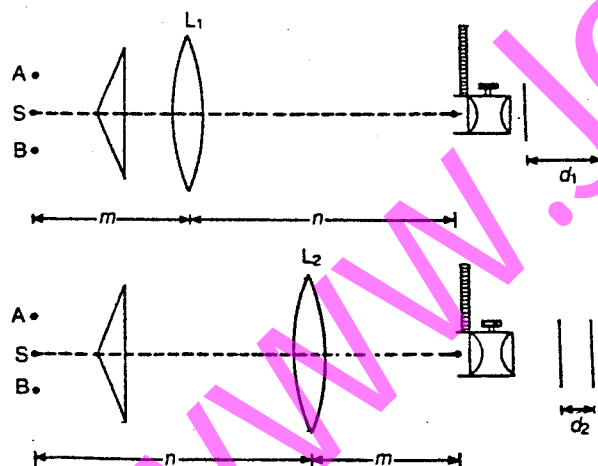

Fig. 8.9

field of view of the eyepiece. Measure the distance between the two images in this case also. Let it be equal to  $d_2$ .

Here,  $v = m$  and  $u = n$ ,

$$\therefore \frac{d_2}{d} = \frac{v}{u} = \frac{m}{n} \quad \dots(iii)$$

From equations (ii) and (iii),

$$\frac{d_1 d_2}{d^2} = 1$$

or

$$d = \sqrt{d_1 d_2}$$

Here  $d_1$  will be greater than  $d_2$  and  $d$  is the geometrical mean of  $d_1$  and  $d_2$ . Therefore  $d$  can be calculated. Substituting the value of  $d$ ,  $\beta$  and  $D$  in equation (i), the wavelength of the given monochromatic light can be determined.

The second method to find  $d$  is to measure accurately the refracting angle  $\alpha$ . As the angle is small, the deviation produced  $\theta = (\mu - 1)\alpha$ . Therefore the total angle between  $Aa$  and  $Ba$  is  $2\theta = 2(\mu - 1)\alpha$ . If the distance between the prism and the slit  $S$  is  $y_1$ , then  $d = 2(\mu - 1)\alpha y_1$ .

Therefore  $d$  can be calculated.

## 8.9 FRINGES WITH WHITE LIGHT USING A BIPRISM

When white light is used, the centre of the fringe at  $C$  is white while the fringes on both sides of  $C$  are coloured because the fringe width ( $\beta$ ) depends upon wavelength. Moreover, the fringes obtained in the case of a biprism using white light are different from the fringes obtained with Fresnel's mirrors. In a biprism, the two coherent virtual sources are produced by refraction and the distance between the two sources depends upon the refractive index, which in turn depends upon the wavelength of light. Therefore, for blue light the distance between the two apparent sources is different to that with red light. The distance of the  $n$ th fringe from the centre (with monochromatic light)

$$x = \frac{n \lambda D}{d}, \quad \text{where } d = (2\mu - 1)\alpha y_1$$

$$\therefore x = \frac{n \lambda D}{2(\mu - 1)\alpha y_1}$$

Therefore for blue and red rays, the  $n$ th fringe will be,

$$x_b = \frac{n \lambda_b D}{2(\mu_b - 1)\alpha y_1} \quad \dots(i)$$

$$x_r = \frac{n \lambda_r D}{2(\mu_r - 1)\alpha y_1} \quad \dots(ii)$$

**Example 8.9.** A biprism is placed 5 cm from a slit illuminated by sodium light ( $\lambda = 5890 \text{ \AA}$ ). The width of the fringes obtained on a screen 75 cm from the biprism is  $9.424 \times 10^{-2}$  cm. What is the distance between the two coherent sources? (Nagpur 1984)

Here  $\lambda = 5890 \times 10^{-8}$  cm  
 $d = ?$ ,  $\beta = 9.424 \times 10^{-2}$  cm  
 $D = 5 + 75 = 80$  cm  
 $\beta = \frac{\lambda D}{d}$   
 or  $d = \frac{5890 \times 10^{-8} \times 80}{9.424 \times 10^{-2}}$   
 or  $d = 0.05$  cm

**Example 8.10.** The inclined faces of a glass prism ( $\mu = 1.5$ ) make an angle of  $1^\circ$  with the base of the prism. The slit is 10 cm from the biprism and is illuminated by light of  $\lambda = 5900 \text{ \AA}$ . Find the fringe width observed at a distance of 1 m from the biprism.

[Delhi B.Sc.(Hons.) 1991]

$\beta = \frac{\lambda D}{d}$   
 $d = 2(\mu - 1) \alpha y_1$   
 Here  $\mu = 1.5$   
 $\alpha = 1^\circ = \frac{\pi}{180}$  radian  
 $y_1 = 10$  cm;  $y_2 = 100$  cm  
 $D = y_1 + y_2 = 10 + 100 = 110$  cm  
 $\lambda = 5900 \times 10^{-8}$  cm.  
 $\beta = ?$   
 $\therefore \beta = \frac{5900 \times 10^{-8} \times 110 \times 180 \times 7}{2(1.5 - 1) \times 22 \times 10}$   
 $= 0.037$  cm

**Example 8.11.** In a biprism experiment with sodium light, bands of width 0.0195 cm are observed at 100 cm from the slit. On introducing a convex lens 30 cm away from the slit, two images of the slit are seen

0.7 cm apart, at 100 cm distance from the slit. Calculate the wave length of sodium light. (Rajasthan, 1985)

$\beta = \frac{\lambda D}{d}$   
 or  $\lambda = \frac{\beta d}{D}$   
 Here  $\beta = 0.0195$  cm  
 $D = 100$  cm.  
 For a convex lens  
 $\frac{1}{O} = \frac{v}{u}$ ,  $u + v = 100$  cm  
 $u = 30$  cm  
 or  $\frac{0.7}{O} = \frac{70}{30}$  cm  
 or  $O = 0.30$  cm  
 i.e. Distance between the two coherent sources,  
 $d = O = 0.30$  cm  
 $\therefore \lambda = \frac{0.0195 \times 0.30}{100} = 5850 \times 10^{-8}$  cm  
 or  $\lambda = 5850 \text{ \AA}$

**Example 8.12.** Interference fringes are observed with a biprism of refracting angle  $1^\circ$  and refractive index 1.5 on a screen 80 cm away from it. If the distance between the source and the biprism is 20 cm, calculate the fringe width when the wavelength of light used is (i) 6900  $\text{\AA}$  and (ii) 5890  $\text{\AA}$  (Kanpur, 1986)

$\beta = \frac{\lambda D}{d}$   
 $d = 2(\mu - 1) \alpha y_1$   
 Here  $\mu = 1.5$   
 $\alpha = 1^\circ = \frac{\pi}{180}$  radian  
 $y_1 = 20$  cm;  $y_2 = 80$  cm  
 $D = y_1 + y_2 = 20 + 80 = 100$  cm

$$(i) \quad \lambda = 6900 \text{ \AA} \quad \text{or} \quad 6900 \times 10^{-8} \text{ cm}$$

$$\therefore \quad \beta = \frac{\lambda D}{2(\mu - 1) \alpha y_1}$$

$$\beta = \frac{6900 \times 10^{-8} \times 100 \times 180 \times 7}{2(1.5 - 1) \times 22 \times 20}$$

$$\beta = 0.01976 \text{ cm}$$

$$(ii) \quad \lambda = 5890 \text{ \AA}$$

$$\text{or} \quad x = 5890 \times 10^{-8} \text{ cm}$$

$$\beta = \frac{\lambda D}{2(\mu - 1) \alpha y_1}$$

$$\text{or} \quad \beta = \frac{5890 \times 10^{-8} \times 100 \times 180 \times 7}{2(1.5 - 1) \times 22 \times 20}$$

$$\text{or} \quad \beta = 0.01687 \text{ cm}$$

**Example 8.13.** A biprism is placed at a distance of 5 cm in front of a narrow slit, illuminated by sodium light ( $\lambda = 5890 \times 10^{-8}$  cm) and the distance between the virtual sources is found to be 0.05 cm. Find the width of the fringes observed in an eyepiece placed at a distance of 75 cm from the biprism. (Mysore 1981)

$$\text{Here} \quad \lambda = 5890 \times 10^{-8} \text{ cm}, \quad d = 0.05 \text{ cm}$$

$$D = 5 + 75 = 80 \text{ cm}$$

Width of the fringe

$$\beta = \frac{\lambda D}{d} = \frac{5890 \times 10^{-8} \times 80}{0.05}$$

$$\beta = 9.424 \times 10^{-8} \text{ cm}$$

**Example 8.14.** In a biprism experiment the eyepiece was placed at a distance of 120 cm from the source. The distance between the two virtual sources was found to be 0.075 cm. Find the wavelength of light of the source if the eyepiece has to be moved through a distance 1.888 cm for 20 fringes to cross the field of view.

$$\text{Here,} \quad n = 20$$

$$l = 1.888 \text{ cm}$$

$$\therefore \text{ Fringe width} \quad \beta = \frac{l}{n} = \frac{1.888}{20} \text{ cm}$$

$$d = 0.075 \text{ cm}, \quad D = 120 \text{ cm}$$

$$\lambda = \frac{\beta d}{D} = \frac{1.888}{20} \times \frac{0.075}{120} = 5900 \times 10^{-8} \text{ cm}$$

$$= 5900 \text{ \AA}$$

**Example 8.15.** In an experiment with Fresnel's biprism, fringes for light of wavelength  $5 \times 10^{-5}$  cm are observed 0.2 mm apart at a distance of 175 cm from the prism. The prism is made of glass of refractive index 1.50 and it is at a distance of 25 cm from the illuminated slit. Calculate the angle at the vertex of the biprism.

$$\text{Here} \quad y_1 = 25 \text{ cm}, \quad y_2 = 175 \text{ cm}$$

$$\beta = 0.2 \text{ mm} = 0.02 \text{ cm}$$

$$\lambda = 5 \times 10^{-5} \text{ cm}$$

$$\mu = 1.50$$

$$\alpha = ?$$

$$d = 2(\mu - 1) \alpha \cdot y_1 \quad \dots(i)$$

$$\text{But} \quad \beta = \frac{\lambda D}{d}$$

$$\text{or} \quad d = \frac{\lambda D}{\beta} \quad \dots(ii)$$

From equations (i) and (ii)

$$\frac{\lambda D}{\beta} = 2(\mu - 1) \alpha \cdot y_1$$

$$\text{Also} \quad D = y_1 + y_2$$

$$\therefore \quad \frac{\lambda (y_1 + y_2)}{\beta} = 2(\mu - 1) \alpha \cdot y_1$$

$$\text{or} \quad \alpha = \frac{\lambda (y_1 + y_2)}{2\beta (\mu - 1) y_1} = \frac{5 \times 10^{-5} (25 + 175)}{2 \times 0.02 (1.5 - 1) 25}$$

$$= 0.02 \text{ radian}$$

$$\text{The vertex angle } \theta = (\pi - 2\alpha) \text{ radian} = (\pi - 0.04) \text{ radian}$$

$$\theta = 177^\circ 42'$$

**Example 8.16.** Calculate the separation between the coherent sources formed by a biprism whose inclined faces make angles of 1 degree with its base. The slit source is 20 cm away from the biprism and  $\mu$  of the biprism material = 1.5.

$$d = 2(\mu - 1) \alpha y_1$$

Here

$$\mu = 1.5, \quad \alpha = 1^\circ = \frac{\pi}{180} \text{ radian}$$

$$y_1 = 20 \text{ cm}$$

$$d = \frac{2(1.5 - 1) \pi \times 20}{180} = \frac{2 \times 0.5 \times 22 \times 20}{7 \times 180}$$

$$= 0.35 \text{ cm}$$

**Example 8.17.** Calculate the separation between the coherent sources formed by a biprism whose inclined faces make angles of  $2^\circ$  with its base, the slit source being 10 cm away from the biprism ( $\mu = 1.50$ ). (Delhi 1974, 1977)

$$d = 2(\mu - 1) \alpha y_1$$

Here

$$\mu = 1.50$$

$$\alpha = 2^\circ = \frac{2 \times \pi}{180} = \frac{\pi}{90} \text{ radian}$$

$$y_1 = 10 \text{ cm}$$

$$d = \frac{2(1.5 - 1) \times 10}{90} = \frac{2 \times 0.5 \times \pi \times 10}{90}$$

$$= 0.35 \text{ cm}$$

**Example 8.18.** In a biprism experiment, the eye-piece is placed at a distance of 1.2 m from the source. The distance between the virtual sources was found to be  $7.5 \times 10^{-4}$  m. Find the wavelength of light, if the eye-piece is to be moved transversely through a distance of 1.888 cm for 20 fringes. (Delhi 1985)

$$\beta = \frac{\lambda D}{d}; \quad \beta = \frac{l}{n}$$

$$\frac{l}{n} = \frac{\lambda D}{d}$$

$$\lambda = \frac{ld}{nD}$$

$$l = 1.888 \text{ cm} = 0.01888 \text{ m}$$

$$d = 7.5 \times 10^{-4} \text{ m}$$

$$n = 2.0$$

$$D = 1.2 \text{ m}$$

$$\lambda = \frac{0.01888 \times 7.5 \times 10^{-4}}{20 \times 1.2}$$

$$= 5900 \times 10^{-10} \text{ m}$$

$$= 5900 \text{ \AA}$$

**Example 8.19.** The inclined faces of a biprism of refractive index 1.50 make angle of  $2^\circ$  with the base. A slit illuminated by a monochromatic light is placed at a distance of 10 cm from the biprism. If the distance between two dark fringes observed at a distance of 1 cm from the prism is 0.18 mm, find the wavelength of light used.

[Delhi (Hons) 1991]

Here,

$$\beta = \frac{\lambda D}{d} \quad \therefore \quad \lambda = \frac{\beta d}{D}$$

$$\beta = 0.18 \text{ mm} = 0.18 \times 10^{-3} \text{ m}$$

$$d = 2(\mu - 1) \alpha y_1$$

$$m = 1.5$$

$$\alpha = 2^\circ = \frac{2 \times \pi}{180} = \frac{\pi}{90} \text{ radian}$$

$$y_1 = 10 \text{ cm} = 0.1 \text{ m}; \quad y_2 = 1 \text{ m}$$

$$D = y_1 + y_2 = 0.1 + 1 = 1.1 \text{ m}$$

$$\lambda = ?$$

$$d = \frac{2(1.5 - 1) \pi \times 0.1}{90} = 3.49 \times 10^{-3}$$

$$\lambda = \frac{\beta d}{D}$$

$$\lambda = \frac{0.18 \times 10^{-3} \times 3.49 \times 10^{-3}}{1.1} = 5.711 \times 10^{-7} \text{ m}$$

$$\lambda = 5711 \text{ \AA}$$

### 8.10 DETERMINATION OF THE THICKNESS OF A THIN SHEET OF TRANSPARENT MATERIAL

The biprism experiment can be used to determine the thickness of a given thin sheet of transparent material e.g., glass or mica.

of  $V$  and  $R$ . Interference occurs between the beams from  $V R$  and those from  $V' R'$ . The violet fringes are produced by  $V$  and  $V'$  while the red fringes are produced by  $R$  and  $R'$ .

Suppose,  $VV' = d_1$  and  $RR' = d_2$

If  $\frac{\lambda}{d_1} = \frac{\lambda}{d_2}$ , the fringe width  $\beta$  will be the same and interference

fringes due to different colours will overlap and white achromatic fringes are produced in the field of view. The white and dark fringes are seen through the eyepiece or can be produced on the screen.

Instead of a diffraction grating, a prism of small angle can also be used.

### 8.15 INTERFERENCE IN THIN FILMS

Newton and Hooke observed and developed the interference phenomenon due to multiple reflections from the surface of thin transparent materials. Everyone is familiar with the beautiful colours produced by a thin film of oil on the surface of water and also by the thin film of a soap bubble. Hooke observed such colours in thin films of mica and similar thin transparent plates. Newton was able to show the interference rings when a convex lens was placed on a plane glass-plate. Young was able to explain the phenomenon on the basis of interference between light reflected from the top and the bottom surface of a thin film. It has been observed that interference in the case of thin films takes place due to (1) reflected light and (2) transmitted light.

### 8.16 INTERFERENCE DUE TO REFLECTED LIGHT (THIN FILMS)

Consider a transparent film of thickness  $t$  and refractive index  $\mu$ . A ray  $SA$  incident on the upper surface of the film is partly reflected along  $AT$  and partly refracted along  $AB$ . At  $B$  part of it is reflected along  $BC$  and finally emerges out along  $CQ$ . The difference in path between the two rays  $AT$  and  $CQ$  can be calculated. Draw  $CN$  normal to  $AT$  and  $AM$  normal to  $BC$ . The angle of incidence is  $i$  and the angle of refraction is  $r$ . Also produce  $CB$  to meet  $AE$  produced at  $P$ . Here  $\angle APC = r$  (Fig. 8.15).

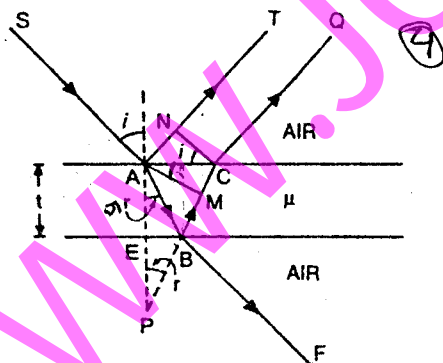

Fig. 8.15

The optical path difference

$$x = \mu(AB + BC) - AN$$

Here,  $\mu = \frac{\sin i}{\sin r} = \frac{AN}{CM}$

$\therefore AN = \mu \cdot CM$

$$x = \mu(AB + BC) - \mu \cdot CM$$

$\therefore x = \mu(AB + BC - CM) = \mu(PC - CM)$   
 $= \mu \cdot PM$

In the  $\triangle APM$ ,

$$\cos r = \frac{PM}{AP}$$

or  $PM = AP \cdot \cos r = (AE + EP) \cos r$   
 $= 2t \cos r$

( $\because AE = EP = t$ )

$\therefore x = \mu \cdot PM = 2\mu t \cos r$  ... (i)

This equation (i), in the case of reflected light does not represent the correct path difference but only the apparent. It has been established on the basis of electromagnetic theory that, when light is reflected from the surface of an optically denser medium (air-medium interface) a phase change  $\pi$  equivalent to a path difference  $\frac{\lambda}{2}$  occurs.

Therefore, the correct path difference in this case,

$$x = 2\mu t \cos r - \frac{\lambda}{2}$$
 ... (ii)

(1) If the path difference  $x = n\lambda$  where  $n = 0, 1, 2, 3, 4$  etc., constructive interference takes place and the film appears bright.

$$\therefore 2\mu t \cos r - \frac{\lambda}{2} = n\lambda$$

or  $2\mu t \cos r = (2n + 1) \frac{\lambda}{2}$  ... (iii)

(2) If the path difference  $x = (2n + 1) \frac{\lambda}{2}$  where  $n = 0, 1, 2$  etc., destructive interference takes place and the film appears dark.

$$\therefore 2\mu t \cos r - \frac{\lambda}{2} = (2n + 1) \frac{\lambda}{2}$$

or  $2\mu t \cos r = (n + 1) \lambda$  ... (iv)

Here  $n$  is an integer only, therefore  $(n + 1)$  can also be taken as  $n$ .

$$2\mu t \cos r = n\lambda \quad \dots(v)$$

where

$$n = 0, 1, 2, 3, 4, \dots \text{etc.}$$

It should be remembered that the interference pattern will not be perfect because the intensities of the rays AT and CQ will not be the same and their amplitudes are different. The amplitudes will depend on the amount of light reflected and transmitted through the films. It has been found that for normal incidence, about 4% of the incident light is reflected and 96% is transmitted. Therefore, the intensity never vanishes completely and perfectly dark fringes will not be observed for the rays AT and CQ alone. But in the case of multiple reflection, the intensity of the minima will be zero.

Consider reflected rays 1, 2, 3 etc. as shown in Fig. 8.16. The amplitude of the incident ray is  $a$ . Let  $r$  be the reflection coefficient,  $t$  the transmission coefficient from rarer to denser medium and  $t'$  the transmission coefficient from denser to rarer medium.

The amplitudes of the reflected rays are:  $ar, atrt', atr^2t', atr^3t' \dots$  etc. The ray 1 is reflected at the surface of a denser medium. It undergoes a phase change  $\pi$ . The rays 2, 3, 4 etc. are all in phase but out of phase with ray 1 by  $\pi$ .

The resultant amplitude of 2, 3, 4 etc. is given by

$$A = atrt' + atr^2t' + atr^3t' + \dots$$

$$A = att'r [1 + r^2 + r^4 + \dots]$$

As  $r$  is less than 1, the terms inside the brackets form a geometric series.

$$A = att'r \left[ \frac{1}{1-r^2} \right] = \left[ \frac{att'r}{1-r^2} \right]$$

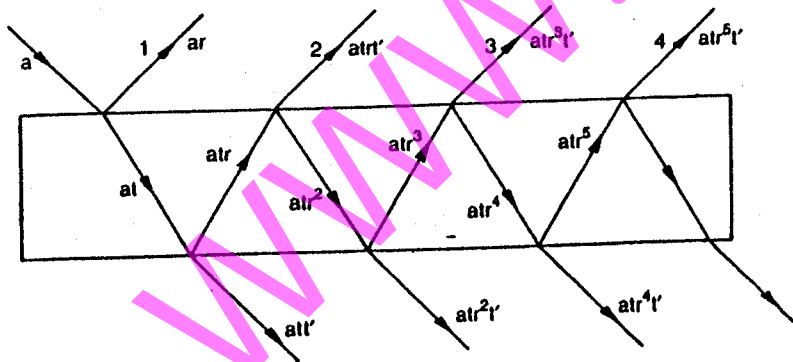

Fig. 8.16

According to the principle of reversibility,

$$tt' = 1 - r^2$$

$$\therefore A = \frac{a(1-r^2)r}{(1-r^2)} = ar$$

Thus, the resultant amplitude of 2, 3, 4...etc. is equal in magnitude of the amplitude of ray 1 but out of phase with it. Therefore the minima of the reflected system will be of zero intensity.

### 8.17 INTERFERENCE DUE TO TRANSMITTED LIGHT (THIN FILMS)

Consider a thin transparent film of thickness  $t$  and refractive index  $\mu$ . A ray SA after refraction goes along AB. At B it is partly reflected along BC and partly refracted along BR. The ray BC after reflection at C, finally emerges along DQ. Here at B and C reflection takes place at the rarer medium (medium-air interface). Therefore, no phase change occurs. Draw BM normal to CD and DN normal to BR. The optical path difference between DQ and BR is given by,

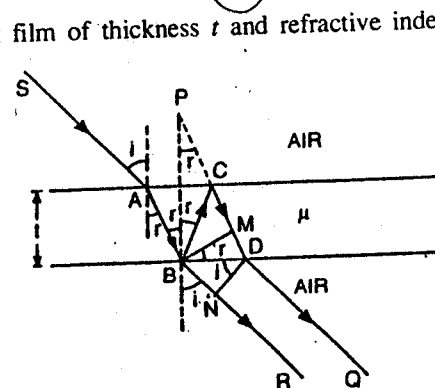

Fig. 8.17.

$$x = \mu(BC + CD) - BN$$

Also

$$\mu = \frac{\sin i}{\sin r} = \frac{BN}{MD} \text{ or } BN = \mu MD$$

In Fig. 8.17,

$$\angle BPC = r \text{ and } CP = BC = CD$$

$$\therefore BC + CD = PD$$

$$\therefore x = \mu(PD) - \mu(MD) = \mu(PD - MD) = \mu PM$$

$$\text{In the } \triangle BPM, \cos r = \frac{PM}{BP} \text{ or } PM = BP \cos r$$

But,

$$BP = 2t$$

$\therefore$

$$PM = 2t \cos r$$

$\therefore$

$$x = \mu PM = 2\mu t \cos r \quad \dots(i)$$

(i) For bright fringes, the path difference  $x = n\lambda$

$$\therefore 2\mu t \cos r = n\lambda \quad \dots(ii)$$

where  $n = 0, 1, 2, 3, \dots$  etc.

(ii) For dark fringes, the path difference  $x = (2n+1)\frac{\lambda}{2}$

$$\therefore 2\mu t \cos r = \frac{(2n+1)\lambda}{2}$$

where  $n = 0, 1, 2, 3, \dots$  etc.

In the case of transmitted light, the interference fringes obtained are less distinct because the difference in amplitude between  $BR$  and  $DQ$  is very large. However, when the angle of incidence is nearly  $45^\circ$ , the fringes are more distinct.

### 8.18 INTENSITIES OF MAXIMA AND MINIMA IN THE INTERFERENCE PATTERN OF REFLECTED AND TRANSMITTED BEAMS IN THIN FILMS

The intensity of the transmitted beam is given by (vide theory of Fabry-Perot Interferometer)

$$I_t = \frac{I_0}{1 + \frac{4r^2}{(1-r^2)^2} \sin^2 \frac{\delta}{2}}$$

Here  $\delta$  is the phase difference,  $r^2$  is the reflection coefficient and  $I_0$  is the maximum intensity.

For values of  $\delta = \pi, 3\pi, 5\pi$  etc.

$$\sin^2 \frac{\delta}{2} = 1$$

For  $r^2 = 0.04$  [i.e. Reflectance of 4%]

$$I_t = \frac{I_0}{1 + \frac{4 \times 0.04}{(1-0.04)^2}}$$

$$I_t = 0.8521 I_0$$

Taking

$$I_0 = 1$$

$$I_t = 85.21\%$$

and

$$I_r = 100 - 85.21 = 14.79\%$$

(1) In the reflected system, the intensity of the interference maxima will be 14.79% of the incident intensity and the intensity of the minima will be zero (Fig. 8.18).

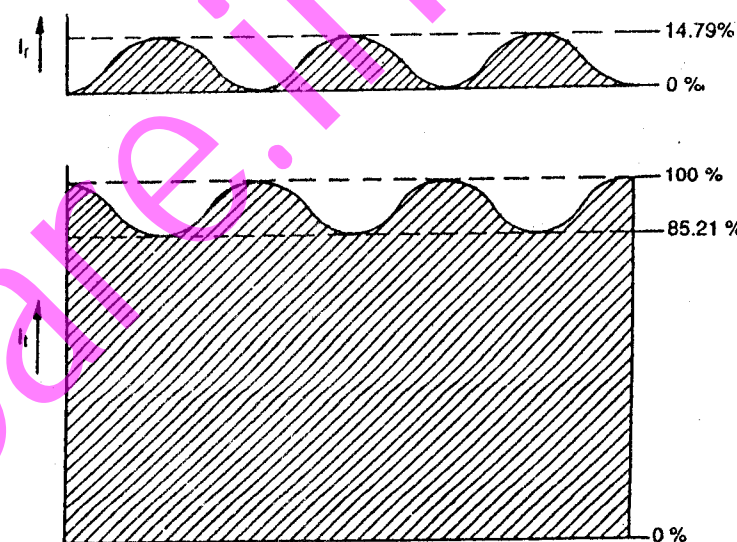

Fig. 8.18

(2) In the transmitted system, the intensity of the maxima will be 100% and intensity of the minima will be 85.21%. It means the visibility of the fringes is much higher in the reflected system than in the transmitted system. Thus the fringes are more sharp in reflected light.

### 8.19 COLOURS OF THIN FILMS

When white light is incident on a thin film, the light which comes from any point from it will not include the colour whose wavelength satisfies the equation  $2\mu t \cos r = n\lambda$ , in the reflected system. Therefore, the film will appear coloured and the colour will depend upon the thickness and the angle of inclination. If  $r$  and  $t$  are constant, the colour will be uniform. In the case of oil on water, different colours are seen because  $r$  and  $t$  vary. This is clear from the following solved example.

**Example 8.29.** A parallel beam of light ( $\lambda = 5890 \times 10^{-8}$  cm) is incident on a thin glass plate ( $\mu = 1.5$ ) such that the angle of refraction into the plate is  $60^\circ$ . Calculate the smallest thickness of the glass plate which will appear dark by reflection. (Punjab 1973)

## 8.20 NECESSITY OF A BROAD SOURCE

Interference fringes obtained in the case of Fresnel's biprism, inclined mirrors and Lloyd's single mirror were produced by two coherent sources. The source used is narrow. These fringes can be obtained on the screen or can be viewed with an eyepiece. In the case of interference in thin films, the narrow source limits the visibility of the film.

Consider a thin film and a narrow source of light at  $S$  (Fig. 8.19). The ray 1 produces interference fringes because 3 and 4 reach the eye whereas the ray 2 meets the surface at some different angle and is reflected along 5 and 6. Here, 5 and 6 do not reach the eye. Similarly we can take other rays incident at different angles on the film surface which do not reach the eye. Therefore, the portion  $A$  of the film is visible and not the rest.

If an extended source of light is used (Fig. 8.20), the ray 1 after reflection from the upper and the lower surface of the film emerges as

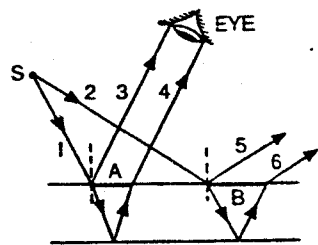

Fig. 8.19.

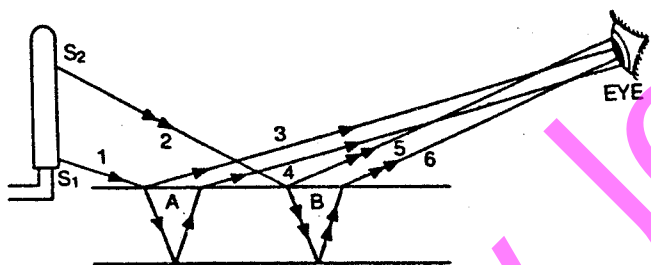

Fig. 8.20

3 and 4 which reach the eye. Also ray 2 from some other point of the source after reflection from the upper and the lower surfaces of the film emerges as 5 and 6 which also reach the eye. Therefore, in the case of such a source of light, the rays incident at different angles on the film are accommodated by the eye and the field of view is large. Due to this reason, to observe interference phenomenon in thin films, a broad source of light is required. With a broad source of light, rays of light are incident at different angles and the reflected parallel beams reach the eye or the microscope objective. Each such ray of light has its origin at a different point on the source.

## 8.21 FRINGES PRODUCED BY A WEDGE SHAPED THIN FILM

Consider two plane surfaces  $OA$  and  $OB$  inclined at an angle  $\theta$  and enclosing a wedge shaped air film. The thickness of the air film increases from  $O$  to  $A$  (Fig. 8.21). When the air film is viewed with reflected monochromatic light, a system of equidistant interference fringes are observed which are parallel to the line of intersection of the two surfaces. The interfering rays do not enter the eye parallel to each other but they appear to diverge from a point near the film. The effect is best observed when the angle of incidence is small.

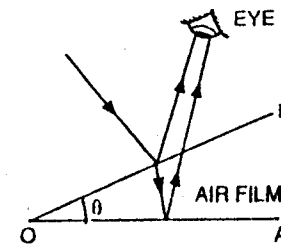

Fig. 8.21.

Suppose the  $n$ th bright fringe occurs at  $P_n$  (Fig. 8.22). The thickness of the air film at  $P_n = P_n Q_n$ . As the angle of incidence is small,  $\cos r = 1$

Applying the relation for a bright fringe,

$$2\mu t \cos r = (2n+1) \frac{\lambda}{2}$$

Here, for air  $\mu = 1$  and  $\cos r = 1$

$$\text{and } t = P_n Q_n$$

$$\therefore 2P_n Q_n = (2n+1) \frac{\lambda}{2} \quad \dots(i)$$

The next bright fringe  $(n+1)$  will occur at  $P_{n+1}$ , such that

$$2P_{n+1} Q_{n+1} = [2(n+1)+1] \frac{\lambda}{2}$$

$$\text{or } 2P_{n+1} Q_{n+1} = (2n+3) \frac{\lambda}{2} \quad \dots(ii)$$

Subtracting (i) from (ii)

$$P_{n+1} Q_{n+1} - P_n Q_n = \frac{\lambda}{2} \quad \dots(iii)$$

Thus the next bright fringe will occur at the point where the thickness of the air film increases by  $\frac{\lambda}{2}$ . Suppose the  $(n+m)$ th bright

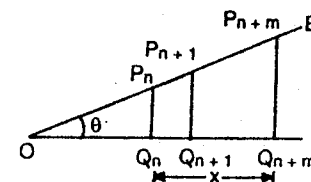

Fig 8.22



fringe is at  $P_{n+m}$ . Then, there will be  $m$  bright fringes between  $P_n$  and  $P_{n+m}$  such that

$$P_{n+m} Q_{n+m} - P_n Q_n = \frac{m\lambda}{2} \quad \dots(iv)$$

If the distance  $Q_n Q_{n+m} = x$

$$\theta = \frac{P_{n+m} Q_{n+m} - P_n Q_n}{Q_n Q_{n+m}} = \frac{\frac{m\lambda}{2}}{x} = \frac{m\lambda}{2x} \quad \dots(v)$$

or  $x = \frac{m\lambda}{2\theta} \quad \dots(vi)$

Therefore, the angle of inclination between  $OA$  and  $OB$  can be known. Here,  $x$  is the distance corresponding to  $m$  fringes. The fringe width

$$\beta = \frac{x}{m} = \frac{\lambda}{2\theta} \quad \dots(vii)$$

## 8.22 TESTING THE PLANENESS OF SURFACES

If the two surfaces  $OA$  and  $OB$  are perfectly plane, the air-film gradually varies in thickness from  $O$  to  $A$ . The fringes are of equal thickness because each fringe is the locus of the points at which the thickness of the film has a constant value (Fig. 8.23).

This is an important application of the phenomenon of interference. If the fringes are not of equal thickness it means the surfaces are not plane. The standard method is to take an optically plane surface  $OA$  and the surface to be tested  $OB$ . The fringes are observed in the field of view and if they are of equal thickness the surface  $OB$  is plane. If not, the surface  $OB$  is not plane. The surface  $OB$  is polished and the process is repeated. When the fringes observed are of equal width, it means that the surface  $OB$  is plane.

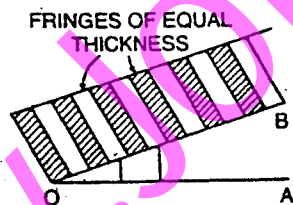

Fig. 8.23.

**Example 8.36.** Two glass plates enclose a wedge shaped air film, touching at one edge and are separated by a wire of 0.05 mm diameter at a distance of 15 cm from the edge. Calculate the fringe width. Monochromatic light of  $\lambda = 6,000 \text{ \AA}$  from a broad source falls normally on the film. (Rajasthan 1989)

$$x = 15 \text{ cm}, \quad \lambda = 6000 \text{ \AA} = 6000 \times 10^{-8} \text{ cm}$$

$$AB = 0.005 \text{ cm}$$

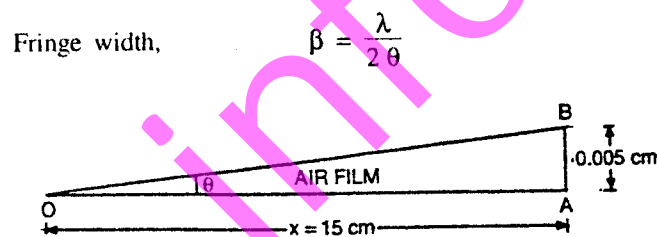

Fig. 8.24

$$\theta = \frac{AB}{OA} = \frac{0.005}{15}$$

$$\beta = \frac{\lambda}{2\theta} = \frac{6000 \times 10^{-8} \times 15}{2 \times 0.005} = 0.09 \text{ cm}$$

**Example 8.37.** Light of wavelength  $6000 \text{ \AA}$  falls normally on a thin wedge shaped film of refractive index 1.4, forming fringes that are 2 mm apart. Find the angle of the wedge. [Delhi (Hons.) 1986]

$$\beta = \frac{\lambda}{2\theta\mu} \quad \theta = \frac{\lambda}{2\mu\beta}$$

Here

$$\lambda = 6000 \text{ \AA} = 6000 \times 10^{-8} \text{ cm}$$

$$\mu = 1.4 ; \quad \beta = 2 \text{ mm} = 0.2 \text{ cm}$$

$$\therefore \theta = \frac{6000 \times 10^{-8}}{2 \times 1.4 \times 0.2}$$

$$\theta = 1.07 \times 10^{-4} \text{ radian}$$

**Example 8.38.** A glass wedge of angle 0.01 radian is illuminated by monochromatic light of wavelength  $6000 \text{ \AA}$  falling normally on it. At what distance from the edge of the wedge, will the 10th fringe be observed by reflected light. (Punjab 1984)

Here

$$\theta = 0.01 \text{ radian}, \quad n = 10,$$

$$\lambda = 6000 \times 10^{-8} \text{ cm}$$

$$2t = n\lambda$$

But

$$\theta = \frac{t}{x}$$

or

$$t = \theta x$$

$\therefore$

$$2\theta x = n\lambda$$

$$\lambda = 6 \times 10^{-5} \text{ cm} ; \mu = 1.33$$

$$\theta = \frac{\lambda m}{2\mu x} = \frac{6 \times 10^{-5} \times 11}{2 \times 1.33 \times 12}$$

$$= 2.0625 \times 10^{-5} \text{ radian.}$$

(ii)  $t = x\theta$

$$x = 12 \text{ cm}$$

$$\theta = 2.0625 \times 10^{-5} \text{ radian.}$$

$$\therefore t = 2.475 \times 10^{-4} \text{ cm.}$$

**Example 8.44.** A beam of monochromatic light of wavelength  $5.82 \times 10^{-7} \text{ m}$  falls normally on a glass wedge with the wedge angle of 20 seconds of an arc. If the refractive index of glass is 1.5, find the number of dark interference fringes per cm of the wedge length. (IAS, 1987)

$$\theta = 20 \text{ seconds of an arc}$$

$$= \frac{20 \times \pi}{60 \times 60 \times 180} \text{ radian}$$

$$\lambda = 5.82 \times 10^{-7} \text{ m} ; \mu = 1.5$$

$$\beta = \frac{\lambda}{2\theta\mu} = \frac{5.82 \times 10^{-7} \times 60 \times 60 \times 180}{2 \times 20 \times \pi \times 1.5}$$

$$= 2 \times 10^{-3} \text{ m} = 0.2 \text{ cm}$$

$$\text{Number of fringes per cm} = \frac{1}{0.2} = 5 \text{ per cm}$$

**Example 8.45.** Two pieces of plane glass are placed together with a piece of paper between the two at one edge. Find the angle in seconds, of the wedge shaped air film between the plates, if on viewing the film normally with monochromatic light (blue) of wavelength  $4800 \text{ \AA}$  there are 18 bands per cm. (Delhi, 1992)

Fringe width,

$$\beta = \frac{1}{18} \text{ cm} = \frac{1}{1800} \text{ m}$$

$$\beta = \frac{\lambda}{2\theta} \therefore \theta = \frac{\lambda}{2\beta}$$

Here  $\lambda = 4800 \text{ \AA} = 4.8 \times 10^{-7} \text{ m}$

Linear circuit analysis  
Di Carlo

$$\theta = \frac{4.8 \times 10^{-7} \times 1800}{2 \times 1}$$

$$= 4.32 \times 10^{-4} \text{ radian}$$

$$\theta = \frac{4.32 \times 10^{-4} \times 180 \times 60 \times 60}{3.14} \text{ sec. of an arc}$$

$$= 89 \text{ seconds of an arc}$$

### 8.23 NEWTON'S RINGS

When a plano-convex lens of long focal length is placed on a plane glass plate, a thin film of air is enclosed between the lower surface of the lens and the upper surface of the plate. The thickness of the air film is very small at the point of contact and gradually increases from the centre

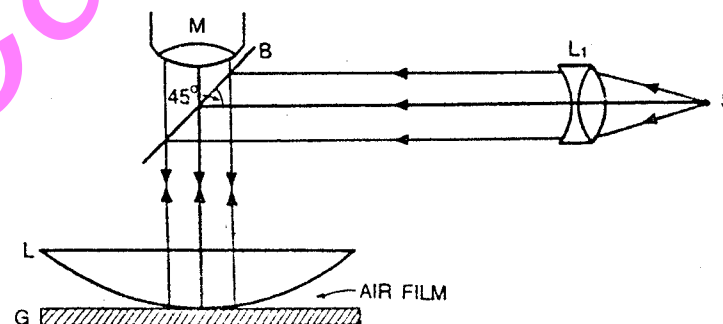

Fig. 8.25

outwards. The fringes produced with monochromatic light are circular. The fringes are concentric circles, uniform in thickness and with the point of contact as the centre. When viewed with white light, the fringes are coloured. With monochromatic light, bright and dark circular fringes are produced in the air film.

$S$  is a source of monochromatic light at the focus of the lens  $L_1$  (Fig. 8.25). A horizontal beam of light falls on the glass plate  $B$  at  $45^\circ$ . The glass plate  $B$  reflects a part of the incident light towards the air film enclosed by the lens  $L$  and the plane glass plate  $G$ . The reflected beam from the air film is viewed with a microscope. Interference takes place and dark and bright circular fringes are produced. This is due to the interference between the light reflected from the lower surface of the lens and the upper surface of the glass plate  $G$ .

**Theory. (i) Newton's rings by reflected light.** Suppose the radius of curvature of the lens is  $R$  and the air film is of thickness  $t$  at a distance of  $OQ = r$ , from the point of contact  $O$ .

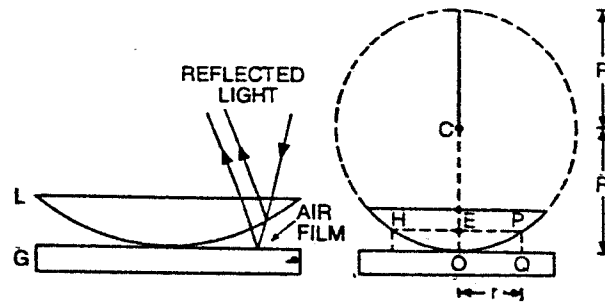

Fig. 8.26

Here, interference is due to reflected light. Therefore, for the bright rings

$$2\mu t \cos \theta = (2n-1) \frac{\lambda}{2} \quad \dots(i)$$

where  $n = 1, 2, 3 \dots$  etc.

Here,  $\theta$  is small, therefore  $\cos \theta = 1$

For air,  $\mu = 1$

$$2t = (2n-1) \frac{\lambda}{2} \quad \dots(ii)$$

For the dark rings,

$$2\mu t \cos \theta = n\lambda$$

or  $2t = n\lambda$

where  $n = 0, 1, 2, 3 \dots$  etc.  $\dots(iii)$

In Fig. 8.26,

$$EP \times HE = OE \times (2R - OE)$$

But  $EP = HE = r$ ,  $OE = PQ = t$

and  $2R - t = 2R$  (approximately)

$$r^2 = 2Rt$$

or  $t = \frac{r^2}{2R}$

Substituting the value of  $t$  in equations (ii) and (iii),

For bright rings

$$r^2 = \frac{(2n-1) \lambda R}{2} \quad \dots(iv)$$

$$r = \sqrt{\frac{(2n-1) \lambda R}{2}} \quad \dots(v)$$

For dark rings,

$$r^2 = n \lambda R \quad \dots(vi)$$

$$r = \sqrt{n \lambda R} \quad \dots(vii)$$

When  $n = 0$ , the radius of the dark ring is zero and the radius of the bright ring is  $\sqrt{\frac{\lambda R}{2}}$ . Therefore, the centre is dark. Alternately dark and bright rings are produced (Fig. 8.27).

**Result.** The radius of the dark ring is proportional to (i)  $\sqrt{n}$  (ii)  $\sqrt{\lambda}$  and (iii)  $\sqrt{R}$ . Similarly the radius of the bright ring is proportional to

$$(i) \sqrt{\frac{2n-1}{2}} \quad (ii) \sqrt{\lambda} \quad \text{and} \quad (iii) \sqrt{R}.$$

If  $D$  is the diameter of the dark ring,

$$D = 2r = 2\sqrt{n \lambda R} \quad \dots(viii)$$

For the central dark ring

$$n = 0$$

$$D = 2\sqrt{0 \lambda R} = 0$$

This corresponds to the centre of the Newton's rings. While counting the order of the dark rings 1, 2, 3, etc. the central ring is not counted.

Therefore for the first dark ring,

$$n = 1$$

$$D_1 = 2\sqrt{\lambda R}$$

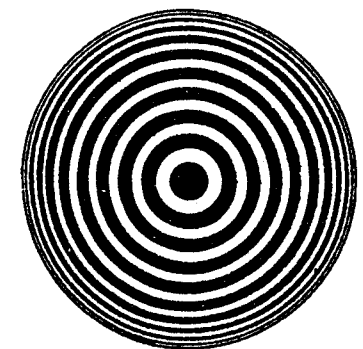

Fig. 8.27.

For the second dark ring,  $n = 2$ ,

$$D_2 = 2\sqrt{2\lambda R}$$

and for the  $n$ th dark ring,

$$D_n = 2\sqrt{n\lambda R}$$

Take the case of 16th and 9th rings,

$$D_{16} = 2\sqrt{16\lambda R} = 8\sqrt{\lambda R},$$

$$D_9 = 2\sqrt{9\lambda R} = 6\sqrt{\lambda R}$$

The difference in diameters between the 16th and the 9th rings,

$$D_{16} - D_9 = 8\sqrt{\lambda R} - 6\sqrt{\lambda R} = 2\sqrt{\lambda R}$$

Similarly the difference in the diameters between the fourth and first rings,

$$D_4 - D_1 = 2\sqrt{4\lambda R} - 2\sqrt{\lambda R} = 2\sqrt{\lambda R}$$

Therefore, the fringe width decreases with the order of the fringe and the fringes got closer with increase in their order.

For bright rings,

$$r^2 = \frac{(2n-1)\lambda R}{2} \quad \dots(ix)$$

or 
$$D^2 = 2(2n-1)\lambda R \quad \dots(x)$$

$$r_n = \sqrt{\frac{(2n-1)\lambda R}{2}} \quad \dots(xi)$$

In equation (ix), substituting  $n = 1, 2, 3$  (number of the ring) the radii of the first, second, third etc., bright rings can be obtained directly.

(ii) **Newton's rings by transmitted light.** In the case of transmitted light (Fig. 8.28), the interference fringes are produced such that for bright rings,

$$2\mu t \cos \theta = n\lambda \quad \dots(xii)$$

and for dark rings

$$2\mu r \cos \theta = (2n-1)\frac{\lambda}{2} \quad \dots(xiii)$$

Here, for air

$$\mu = 1,$$

and  $\cos \theta = 1$

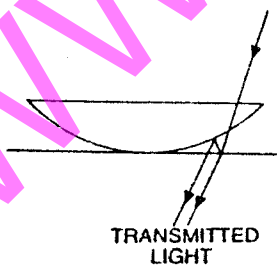

Fig. 8.28

For bright rings,

$$2t = n\lambda$$

and for dark rings  $2t = (2n-1)\frac{\lambda}{2}$

Taking the value of  $t = \frac{r^2}{2R}$ , where  $r$  is the radius of the ring and  $R$  the radius of curvature of the lower surface of the lens, the radius for the bright and dark rings can be calculated.

For bright rings,

$$r^2 = n\lambda R \quad \dots(xiv)$$

For dark rings,

$$r^2 = \frac{(2n-1)\lambda R}{2} \quad \dots(xv)$$

where  $n = 1, 2, 3, \dots$  etc.

When,  $n = 0$ , for bright rings

$$r = 0.$$

Therefore, in the case of Newton's rings due to transmitted light, the central ring is bright (Fig. 8.29) i.e., just opposite to the ring pattern due to reflected light.

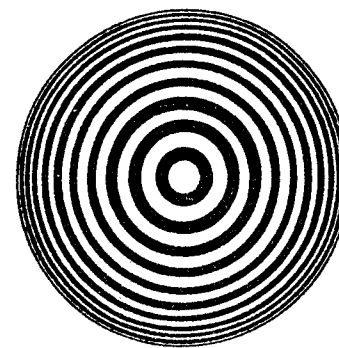

Fig. 8.29.

**Example 8.46.** A thin equiconvex lens of focal length 4 metres and refractive index 1.50 rests on and in contact with an optical flat, and using light of wavelength 5460 Å, Newton's rings are viewed normally by reflection. What is the diameter of the 5th bright ring?

The diameter of the  $n$ th bright ring is given by

$$D_n = \sqrt{2(2n-1)\lambda R}$$

Here  $n = 5$ ,  $\lambda = 5460 \times 10^{-8}$  cm

$$f = 400 \text{ cm}, \mu = 1.50$$

$$\frac{1}{f} = (\mu - 1) \left( \frac{1}{R_1} - \frac{1}{R_2} \right)$$

Here  $R_1 = R$ ,  $R_2 = -R$

$$\therefore \frac{1}{f} = (\mu - 1) \left( \frac{2}{R} \right)$$

$$\frac{1}{400} = (1.50 - 1) \left( \frac{2}{R} \right)$$

$$R = 400 \text{ cm}$$

$$D_n = \sqrt{2 \times (2 \times 5 - 1) \times 5460 \times 10^{-8} \times 400}$$

$$D_n = 0.627 \text{ cm}$$

### 8.24 DETERMINATION OF THE WAVELENGTH OF SODIUM LIGHT USING NEWTON'S RINGS

The arrangement used is shown in Fig. 8.25.  $S$  is a source of sodium light. A parallel beam of light from the lens  $L_1$  is reflected by the glass plate  $B$  inclined at an angle of  $45^\circ$  to the horizontal.  $L$  is a plano-convex lens of large focal length. Newton's rings are viewed through  $B$  by the travelling microscope  $M$  focussed on the air film. Circular bright and dark rings are seen with the centre dark. With the help of a travelling microscope, measure the diameter of the  $n$ th dark ring.

Suppose, the diameter of the  $n$ th ring =  $D_n$

$$r_n^2 = n\lambda R$$

But, 
$$r_n = \frac{D_n}{2}$$

$$\therefore \frac{(D_n)^2}{4} = n\lambda R$$

or 
$$D_n^2 = 4n\lambda R \quad \dots(i)$$

Measure the diameter of the  $n+m$ th dark ring.

Let it be  $D_{n+m}$

$$\therefore \frac{(D_{n+m})^2}{4} = (n+m)\lambda R$$

or 
$$(D_{n+m})^2 = 4(n+m)\lambda R \quad \dots(ii)$$

Subtracting (i) from (ii)

$$(D_{n+m})^2 - (D_n)^2 = 4m\lambda R$$

$$\text{or } \lambda = \frac{(D_{n+m})^2 - (D_n)^2}{4mR} \quad \dots(iii)$$

Hence,  $\lambda$  can be calculated. Suppose the diameters of the 5th ring and the 15th ring are determined. Then,  $m = 15 - 5 = 10$ .

$$\therefore \lambda = \frac{(D_{15})^2 - (D_5)^2}{4 \times 10R} \quad \dots(iv)$$

The radius of curvature of the lower surface of the lens is determined with the help of a spherometer but more accurately it is determined by

Boy's method. Hence the wavelength of a given monochromatic source of light can be determined.

**Example 8.47.** A plano-convex lens of radius 300 cm is placed on an optically flat glass plate and is illuminated by monochromatic light. The diameter of the 8th dark ring in the transmitted system is 0.72 cm. Calculate the wavelength of light used.

[Delhi B.Sc.(Hons) 1986]

For the transmitted system,

$$r^2 = \frac{(2n-1)\lambda R}{2}$$

Here  $n = 8, \quad D = 0.72 \text{ cm}, \quad r = 0.36 \text{ cm}$

$$R = 300 \text{ cm}, \quad \lambda = ?$$

$$\lambda = \frac{2r^2}{(2n-1)R} = \frac{2 \times (0.36)^2}{(2 \times 8 - 1) \times 300}$$

$$= 5760 \times 10^{-8} \text{ cm}$$

$$\lambda = 5760 \text{ \AA}$$

**Example 8.48.** In a Newton's rings experiment the diameter of the 15th ring was found to be 0.590 cm and that of the 5th ring was 0.336 cm. If the radius of the plano-convex lens is 100 cm, calculate the wavelength of light used.

Here  $D_5 = 0.336 \text{ cm}, \quad D_{15} = 0.590 \text{ cm}.$

$$R = 100 \text{ cm}; \quad m = 10,$$

$$\lambda = \frac{(D_{n+m})^2 - (D_n)^2}{4mR} = \frac{D_{15}^2 - D_5^2}{4 \times 10 \times R}$$

$$\lambda = \frac{(0.590)^2 - (0.336)^2}{4 \times 10 \times 100} = 5880 \times 10^{-8} \text{ cm}$$

$$\lambda = 5880 \text{ \AA}$$

**Example 8.49.** In a Newton's rings experiment, the diameter of the 5th ring was 0.336 cm and the diameter of the 15th ring was 0.590 cm. Find the radius of curvature of the plano-convex lens, if the wavelength of light used is 5890 \AA.

Here  $D_5 = 0.336 \text{ cm}, \quad D_{15} = 0.590 \text{ cm},$

and  $m = 10, \quad \lambda = 5890 \times 10^{-8} \text{ cm}, \quad R = ?$

$$R = \frac{(D_{n+m})^2 - (D_n)^2}{4m\lambda} = \frac{D_{15}^2 - D_5^2}{4 \times 10 \times \lambda}$$

$$R = \frac{(0.590)^2 - (0.336)^2}{4 \times 10 \times 5890 \times 10^{-8}}$$

$$= 99.82 \text{ cm}$$

**Example 8.50.** In a Newton's rings experiment, find the radius of curvature of the lens surface in contact with the glass plate when with a light of wavelength  $5890 \times 10^{-8}$  cm, the diameter of the third dark ring is 3.2 mm. The light is falling at such an angle that it passes through the air film at an angle of zero degree to the normal.

[Rajasthan, 1987]

For dark rings

$$r^2 = n\lambda R ; \quad R = \frac{r^2}{n\lambda}$$

Here  $r = \frac{3.2}{2} \text{ mm} = 1.6 \text{ mm} = 0.16 \text{ cm}$

$$n = 3 ; \quad \lambda = 5890 \times 10^{-8} \text{ cm}$$

$$\therefore R = \frac{(0.16)^2}{3 \times 5890 \times 10^{-8}}$$

$$R = 144.9 \text{ cm}$$

### 8.25 REFRACTIVE INDEX OF A LIQUID USING NEWTON'S RINGS

The experiment is performed when there is an air film between the plano-convex lens and the optically plane glass plate. These are kept in a metal container C. The diameter of the  $n$  th and the  $(n+m)$  th dark rings are determined with the help of a travelling microscope (Fig. 8.30).

$$\text{For air, } (D'_{n+m})^2 = 4(n+m)\lambda R ; \quad D_n^2 = 4n\lambda R$$

$$D_{n+m}^2 - D_n^2 = 4m\lambda R \quad \dots(i)$$

The liquid is poured in the container C without disturbing the arrangement. The air film between the lower surface of the lens and the upper surface of the plate is replaced by the liquid. The diameters of the  $n$  th ring and the  $(n+m)$  th ring are determined.

For the liquid,  $2\mu t \cos\theta = n\lambda$  for dark rings

$$\text{or } 2\mu t = n\lambda. \quad \text{But, } t = \frac{r^2}{2R}$$

$$\text{or } \frac{2\mu r^2}{2R} = n\lambda$$

$$\text{or } r^2 = \frac{n\lambda R}{\mu}. \quad \text{But } r = \frac{D}{2} ; \quad D^2 = \frac{4n\lambda R}{\mu}$$

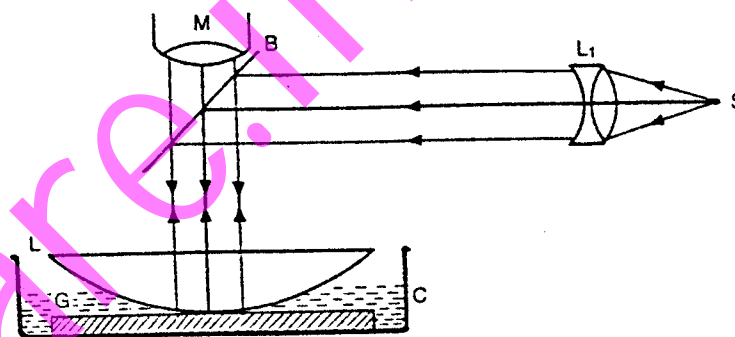

Fig. 8.30

If  $D'_n$  is the diameter of the  $n$  th ring and  $D'_{n+m}$  is the diameter of the  $(n+m)$  th ring

$$\text{then, } (D'_{n+m})^2 = \frac{4(n+m)\lambda R}{\mu} ; \quad (D'_n)^2 = \frac{4n\lambda R}{\mu}$$

$$\text{or } (D'_{n+m})^2 - (D'_n)^2 = \frac{4m\lambda R}{\mu} \quad \dots(ii)$$

$$\text{or } \mu = \frac{4m\lambda R}{(D'_{n+m})^2 - (D'_n)^2} \quad \dots(iii)$$

If  $m, \lambda, R, D'_{n+m}$  and  $D'_n$  are known  $\mu$  can be calculated. If  $\lambda$  is not known, then divide (iii) By (i)

$$\mu = \frac{(D'_{n+m})^2 - (D'_n)^2}{(D'_{n+m})^2 - (D'_n)^2} \quad \dots(iv)$$

**Graphical method.** The diameters of the dark rings are determined for various orders, varying from the  $n$  th ring to the  $(n+m)$  th ring, first with air as the medium and then with the liquid. A graph is plotted between  $D_{n+m}^2$  along the y-axis and  $m$  along the x-axis, where

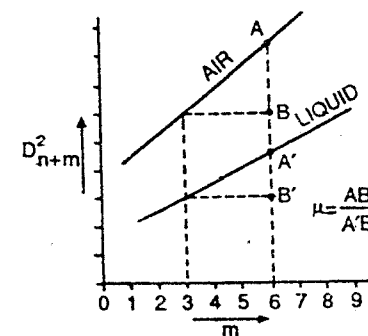

Fig. 8.31

$m = 0, 1, 2, 3, \dots$  etc. The ratio of the slopes of the two lines (air and liquid), gives the refractive index of the liquid.

$$\mu = \frac{AB}{A'B'}$$

**Example 8.51.** In a Newton's rings experiment the diameter of the 10 th ring changes from 1.40 cm to 1.27 cm when a liquid is introduced between the lens and the plate. Calculate the refractive index of the liquid.

(Nagpur 1985)

$$\text{For liquid medium } D_1^2 = \frac{4n\lambda R}{\mu} \quad \dots(i)$$

$$\text{For air medium } D_2^2 = 4n\lambda R \quad \dots(ii)$$

Dividing (ii) by (i)

$$\mu = \left( \frac{D_2}{D_1} \right)^2$$

$$\text{Here } D_1 = 1.27 \text{ cm, } D_2 = 1.40 \text{ cm}$$

$$\therefore \mu = \left( \frac{1.40}{1.27} \right)^2 = 1.215$$

**Example 8.52.** In a Newton's rings arrangement, if a drop of water ( $\mu = 4/3$ ) be placed in between the lens and the plate, the diameter of the 10 th ring is found to be 0.6 cm. Obtain the radius of curvature of the face of the lens in contact with the plate. The wavelength of light used is 6000 Å.

(Delhi 1983)

$$D_n^2 = \frac{4n\lambda R}{\mu} \quad \text{or} \quad R = \frac{\mu D_n^2}{4n\lambda}$$

$$\text{Here } \mu = \frac{4}{3}, D_n = 0.6 \text{ cm}$$

$$n = 10, \lambda = 6000 \text{ Å} = 6 \times 10^{-5} \text{ cm}$$

$$R = ?$$

$$R = \frac{4 \times (0.6)^2}{3 \times 4 \times 10 \times 6 \times 10^{-5}}$$

$$= 200 \text{ cm}$$

**Example 8.53.** Newton's rings are formed by reflected light of wavelength 5895 Å with a liquid between the plane and curved surfaces. If the diameter of the 5 th bright ring is 3 mm and the radius of curvature of the curved surface is 100 cm, calculate the refractive index of the liquid.

(Gorakhpur 1986)

Here, for the  $n$  th bright ring,

$$\mu = \frac{(2n-1)\lambda R}{2r^2}$$

$$\text{Here } n = 5, \lambda = 5895 \times 10^{-8} \text{ cm, } R = 100 \text{ cm, } r = \frac{3}{2} \text{ mm} = 0.15 \text{ cm}$$

$$\mu = ?$$

$$\mu = \frac{(2 \times 5 - 1) \times 5895 \times 10^{-8} \times 100}{2(0.15)^2}$$

$$\mu = 1.179$$

**Example 8.54.** In a Newton's rings experiment the diameter of the 15 th ring was found to be 0.590 cm and that of the 5 th ring was 0.336 cm. If the radius of the plano-convex lens is 100 cm, calculate the wavelength of light used.

(Delhi ; 1984)

$$\text{Here } D_5 = 0.336 \text{ cm} = 3.36 \times 10^{-3} \text{ m}$$

$$D_{15} = 0.590 \text{ cm} = 5.90 \times 10^{-3} \text{ m}$$

$$R = 100 \text{ cm} = 1 \text{ m, } \lambda = ?$$

$$\lambda = \frac{(D_{n+m})^2 - D_n^2}{4mR} = \frac{D_{15}^2 - D_5^2}{4 \times 10 \times R}$$

$$\lambda = \frac{(5.9 \times 10^{-3})^2 - (3.36 \times 10^{-3})^2}{4 \times 10 \times 1}$$

$$= 5.880 \times 10^{-7} \text{ m}$$

$$\lambda = 5880 \text{ Å}$$

**Example 8.55.** In a Newton's rings experiment the diameter of the 12 th ring changes from 1.50 cm to 1.35 cm when a liquid is introduced between the lens and the plate. Calculate the refractive index of the liquid.

(Delhi 1990)

For liquid medium

$$D_1^2 = \frac{4n\lambda R}{\mu} \quad \dots(i)$$

For air medium

$$D_2^2 = 4n\lambda R \quad \dots(ii)$$

Dividing (ii) by (i)

$$\mu = \left( \frac{D_2}{D_1} \right)^2$$

Here

$$D_1 = 1.35 \text{ cm}$$

$$D_2 = 1.50 \text{ cm}$$

$$\mu = \left( \frac{1.50}{1.35} \right)^2$$

$$\mu = 1.235$$

**Example 8.56.** Newton's rings are observed in reflected light of  $\lambda = 5.9 \times 10^{-5}$  cm. The diameter of the 10th dark ring is 0.5 cm. Find the radius of curvature of the lens and the thickness of the air film.

(Delhi, 1991)

(i) Here.

$$r^2 = n \lambda R$$

$$\lambda = 5.9 \times 10^{-5} \text{ cm} = 5.9 \times 10^{-7} \text{ m}$$

$$n = 10$$

$$\therefore R = \frac{(2.5 \times 10^{-3})^2}{10 \times 5.9 \times 10^{-7}}$$

$$R = 1.059 \text{ m}$$

(ii) Thickness of the air film =  $t$

$$2t = n\lambda$$

$$t = \frac{n\lambda}{2}$$

$$= \frac{10 \times 5.9 \times 10^{-7}}{2}$$

$$t = 2.95 \times 10^{-6} \text{ m}$$

## 8.26 NEWTON'S RINGS FORMED BY TWO CURVED SURFACES

Consider two curved surfaces of radii of curvature  $R_1$  and  $R_2$  in contact at the point  $O$ . A thin air film is enclosed between the two surfaces (Fig. 8.32). The dark and bright rings are formed and can be viewed with a travelling microscope. Suppose the radius of the  $n$ th dark ring =  $r$ . The thickness of the air film at  $P$ , is

$$PQ = PT - QT$$

From geometry,

$$PT = \frac{r^2}{2R_1}$$

and

$$QT = \frac{r^2}{2R_2}$$

$$\therefore PQ = \frac{r^2}{2R_1} - \frac{r^2}{2R_2}$$

But  $PQ = t$

For reflected light,

$$2\mu t \cos \theta = n\lambda, \text{ for dark rings.}$$

Here, for air

$$\mu = 1$$

$$\cos \theta = 1$$

$$2t = n\lambda$$

or

$$2 \left( \frac{r^2}{2R_1} - \frac{r^2}{2R_2} \right) = n\lambda$$

$$r^2 \left[ \frac{1}{R_1} - \frac{1}{R_2} \right] = n\lambda \quad \dots(i)$$

where

$$n = 0, 1, 2, 3 \dots \text{etc.}$$

For bright rings,

$$2\mu t \cos \theta = \frac{(2n+1)\lambda}{2}$$

Taking

$$\mu = 1$$

and

$$\cos \theta = 1$$

$$2t = \frac{(2n+1)\lambda}{2}$$

or

$$r^2 \left( \frac{1}{R_1} - \frac{1}{R_2} \right) = \frac{(2n+1)\lambda}{2} \quad \dots(ii)$$

where  $n = 0, 1, 2, 3 \dots \text{etc.}$

For the 10th bright ring, the value of  $n = 10 - 1 = 9$

$\therefore$  For  $n$ th bright ring,

$$r_n^2 \left( \frac{1}{R_1} - \frac{1}{R_2} \right) = \left[ \frac{[2(n-1)+1]\lambda}{2} \right] = \frac{(2n-1)\lambda}{2} \quad \dots(iii)$$

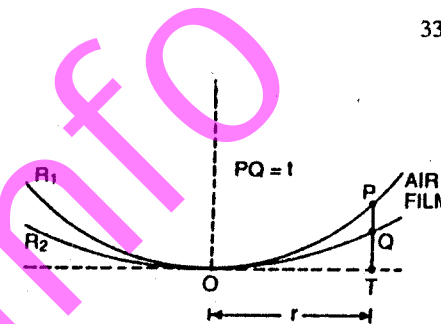

Fig. 8.32.



(b) What do you mean by the term coefficient of finesse ?

(c) Prove that the fringes obtained with Fabry Perot interferometer are sharper than those obtained with Michelson interferometer.

[Delhi (Hons), 1992]

96. (a) Distinguish between spatial and temporal coherence.

(b) What are coherence length and coherence time ? Why is it impossible to observe interference between light waves emitted by independent sources ?

[Delhi (Hons), 1992]

97. Give a complete description of Michelson's interferometer. Discuss how the wavelength of monochromatic radiation can be determined in the laboratory with the help of this interferometer. [Osmania, 1992]

98. Discuss briefly the various methods for obtaining coherent sources of light in the laboratory. [Osmania, 1992]

99. Show that the distance between the two virtual coherent sources in Fresnel's biprism arrangement is  $2d(n-1)\theta$  where  $d$  is the distance between the source and the biprism,  $\theta$  is the angle of the biprism and  $n$  is the refractive index of the material of the biprism. [Osmania, 1992]

## DIFFRACTION

### 9.1 INTRODUCTION

It is a matter of common experience that the path of light entering a dark room through a hole in the window illuminated by sunlight is straight. Similarly, if an opaque obstacle is placed in the path of light, a sharp shadow is cast on the screen, indicating thereby that light travels in straight lines. Rectilinear propagation of light can be easily explained on the basis of Newton's corpuscular theory. But it has been observed that when a beam of light passes through a small opening (a small circular hole or a narrow slit) it spreads to some extent into the region of the geometrical shadow also. If light energy is propagated in the form of waves, then similar to sound waves, one would expect bending of a beam of light round the edges of an opaque obstacle or illumination of the geometrical shadow.

Each progressive wave, according to Huygens wave theory produces secondary waves, the envelope of which forms the secondary wavefront. In Fig. 9.1 (a),  $S$  is a source of monochromatic light and  $MN$  is a small aperture.  $XY$  is the screen placed in the path of light.  $AB$  is the illuminated portion of the screen and above  $A$  and below  $B$  is the region of the geometrical shadow. Considering  $MN$  as the primary wavefront, according to Huygens' construction, if secondary wavefronts are drawn, one would expect encroachment of light in the geometrical shadow. Thus, the shadows formed by small obstacles are not sharp. This bending of light round the edges of an obstacle or the encroachment of light within the geometrical shadow is called diffraction. Similarly, if an opaque obstacle  $MN$  is placed in the path of light [Fig. 9.1 (b)], there should be illumination in the geometrical shadow region  $AB$  also. But the illumination in the geometrical shadow of an obstacle is not commonly observed because the light sources are not point sources and secondly the obstacles used are of very large size compared to the wavelength of light. If a shadow of an obstacle is cast by an extended source, say a frosted electric bulb, light from every point on the surface of the bulb forms its own diffraction pattern (bright

and dark diffraction bands) and these overlap such that no single pattern can be identified. The term diffraction is referred to such problems in which one considers the resultant effect produced by a limited portion of a wavefront.

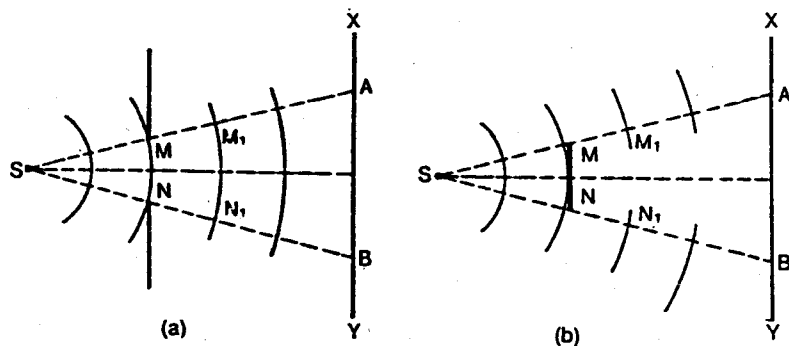

Fig. 9.1

Diffraction phenomena are part of our common experience. The luminous border that surrounds the profile of a mountain just before the sun rises behind it, the light streaks that one sees while looking at a strong source of light with half shut eyes and the coloured spectra (arranged in the form of a cross) that one sees while viewing a distant source of light through a fine piece of cloth are all examples of diffraction effects.

Augustin Jean Fresnel in 1815, combined in a striking manner Huygens wavelets with the principle of interference and could satisfactorily explain the bending of light round obstacles and also the rectilinear propagation of light.

## 9.2 FRESNEL'S ASSUMPTIONS

According to Fresnel, the resultant effect at an external point due to a wavefront will depend on the factors discussed below :-

In Fig. 9.2,  $S$  is a point source of monochromatic light and  $MN$  is a small aperture.  $XY$  is the screen and  $SO$  is perpendicular to  $XY$ .  $MCN$  is the incident spherical wavefront due to the point source  $S$ . To obtain the resultant effect at a point  $P$  on the screen, Fresnel assumed that (1) a wavefront can be divided into a large number of strips or zones called Fresnel's zones of small area and the resultant effect at any point will depend on the combined effect of all the secondary waves emanating from the various zones ; (2) the effect at a point due to any particular zone will depend on the distance of the point from the zone ; (3) the effect at  $P$  will also depend on the obliquity of the point with reference to the zone under consideration, e.g. due to the part of the wavefront at  $C$ , the

effect will be maximum at  $O$  and decreases with increasing obliquity., It is maximum in a direction radially outwards from  $C$  as it decreases in the opposite direction. The effect at a point due to the obliquity factor is proportional to  $(1 + \cos \theta)$  where  $\angle PCO = \theta$ . Considering an elementary wavefront at  $C$ , the effect is maximum at  $O$  because  $\theta = 0$  and  $\cos \theta = 1$ . Similarly, in a direction tangential to the primary wavefront at  $C$  (along  $CQ$ ) the resultant effect is one half of that along

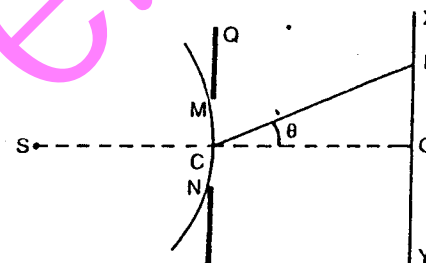

Fig. 9.2

$CO$  because  $\theta = 90^\circ$  and  $\cos 90 = 0$ . In this direction  $CS$ , the resultant effect is zero since  $\theta = 180^\circ$  and  $\cos 180 = -1$  and  $1 + \cos 180 = 1 - 1 = 0$ . This property of the secondary waves eliminates one of the difficulties experienced with the simpler form of Huygens principle viz., that if the secondary waves spread out in all directions from each point on the primary wavefront, they should give a wave travelling forward as well as backward. as the amplitude at the rear of the wave is zero there will evidently be no back wave.

## 9.3 RECTILINEAR PROPAGATION OF LIGHT

$ABCD$  is a plane wavefront perpendicular to the plane of the paper

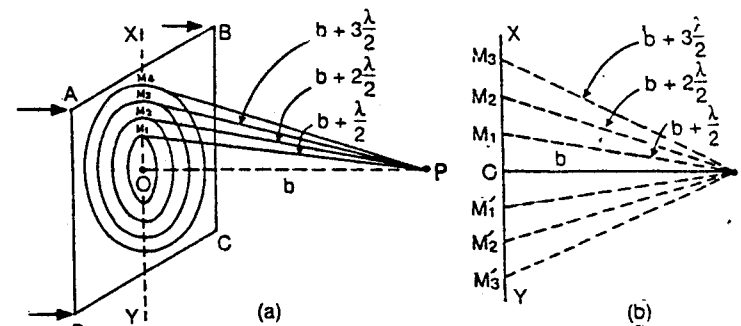

Fig. 9.3

$$\therefore f_1 = \frac{r_1^2}{\lambda} \quad \dots(i)$$

$$f_2 = \frac{r_1^2}{3\lambda} \quad \dots(ii)$$

Also  $\frac{1}{v} - \frac{1}{u} = \frac{1}{f}$

$$\therefore \frac{1}{v_1} - \frac{1}{u} = \frac{1}{f_1}$$

$$\frac{1}{v_2} - \frac{1}{u} = \frac{1}{f_2}$$

Here  $v_1 = 0.3 \text{ m}$  and  $v_2 = 0.6 \text{ m}$

$$\frac{1}{0.3} - \frac{1}{u} = \frac{\lambda}{r_1^2} \quad \dots(iii)$$

$$\frac{1}{0.06} - \frac{1}{u} = \frac{3\lambda}{r_1^2} \quad \dots(iv)$$

Multiplying equation (iii) by 3 and equating with (iv),

$$\frac{1}{0.1} - \frac{3}{u} = \frac{1}{0.06} - \frac{1}{u}$$

$$u = -0.3 \text{ m} \quad \dots(v)$$

Negative sign shows that the point source is to the left of the zone plate and its distance is 0.3 m.

Substituting the value of  $u$  and  $\lambda$  in equation (iii)

$$\frac{1}{0.3} + \frac{1}{0.3} = \frac{5 \times 10^{-7}}{r_1^2}$$

$$r_1 = 2.74 \times 10^{-4} \text{ m} \quad \dots(vi)$$

From equation (i)

$$f_1 = \frac{(2.74 \times 10^{-4})^2}{5 \times 10^{-7}} = 0.15 \text{ m}$$

**Example 9.6.** A zone plate is made by arranging the radii of the circles which define the zones such that they are the same as the radii of newton's rings formed between a plane surface and the surface having radius of curvature 200 cm. Find the principal focal length of the zone plate. [Delhi (Hons) 1992]

For Newton's rings,

radius of the  $n$ th ring,

$$r_n = \sqrt{n\lambda R}$$

$$r_1 = \sqrt{\lambda R}$$

...(i)

For a zone plate, the principal focal length

$$f_1 = \frac{r_1^2}{\lambda}$$

...(ii)

From (i) and (ii)

$$f_1 = \frac{\lambda R}{\lambda} = R$$

But

$$R = 200 \text{ cm} = 2 \text{ m}$$

$$f_1 = 2 \text{ m}$$

## 9.7 FRESNEL AND FRAUNHOFER DIFFRACTION

Diffraction phenomena can conveniently be divided into two groups viz, (i) Fresnel diffraction phenomena and (ii) Fraunhofer diffraction phenomena. In the Fresnel class of diffraction, the source or the screen or both are at finite distances from the aperture or obstacle causing diffraction. In this case, the effect at a specific point on the screen due to the exposed incident wavefront is considered and no modification is made by lenses and mirrors. In such a case, the phenomenon observed on the screen is called Fresnel diffraction pattern. In the Fraunhofer class of diffraction phenomena, the source and the screen on which the pattern is observed are at infinite distances from the aperture or the obstacle causing diffraction. Fraunhofer diffraction pattern can be easily observed in practice. The incoming light is rendered parallel with a lens and the diffracted beam is focussed on the screen with another lens. Observation of Fresnel diffraction phenomena do not require any lenses. Theoretical treatment of Fraunhofer diffraction phenomena is simpler. Fresnel class of diffraction phenomena are treated first in this chapter.

## 9.8 DIFFRACTION AT A CIRCULAR APERTURE

Let  $AB$  be a small aperture (say a pin hole) and  $S$  is a point source of monochromatic light.  $XY$  is a screen perpendicular to the plane of the paper and  $P$  is a point on the screen.  $SP$  is perpendicular to the screen.  $O$  is the centre of the aperture and  $r$  is the radius of the aperture. Let the distance of the source from the aperture be  $a$  ( $SO = a$ ) and the distance of the screen from the aperture be  $b$  ( $OP = b$ ).  $P_1OQ_1$  is the incident spherical wavefront and with reference to the point  $P$ ,  $O$  is the pole of

in the region of the geometrical shadow. The intensity distribution due to Fresnel's diffraction at a straight edge is given in Fig. 9.17 on page 429.

### 9.22 FRAUNHOFER DIFFRACTION AT A SINGLE SLIT

To obtain a Fraunhofer diffraction pattern, the incident wavefront must be plane and the diffracted light is collected on the screen with the help of a lens. Thus, the source of light should either be at a large distance from the slit or a collimating lens must be used.

In Fig. 9.33,  $S$  is a narrow slit perpendicular to the plane of the paper and illuminated by monochromatic light.  $L_1$  is the collimating lens and  $AB$  is a slit of width  $a$ .  $XY$  is the incident spherical wavefront. The light passing through the slit  $AB$  is incident on the lens  $L_2$  and the final refracted beam is observed on the screen  $MN$ . The screen is perpendicular to the

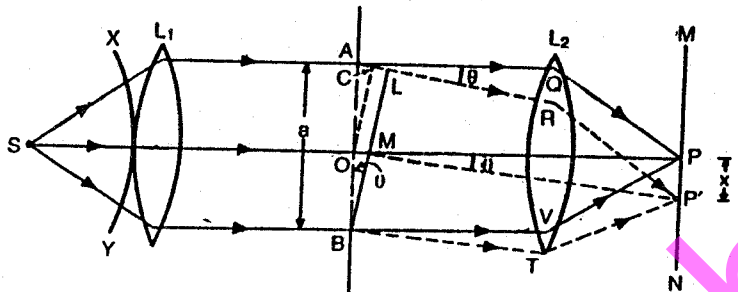

Fig. 9.33

plane of the paper. The line  $SP$  is perpendicular to the screen.  $L_1$  and  $L_2$  are achromatic lenses.

A plane wavefront is incident on the slit  $AB$  and each point on this wavefront is a source of secondary disturbance. The secondary waves travelling in the direction parallel to  $OP$  viz.  $AQ$  and  $BV$  come to focus at  $P$  and a bright central image is observed. The secondary waves from points equidistant from  $O$  and situated in the upper and lower halves  $OA$  and  $OB$  of the wavefront travel the same distance in reaching  $P$  and hence the path difference is zero. The secondary waves reinforce one another and  $P$  will be a point of maximum intensity.

Now, consider the secondary waves travelling in the direction  $AR$ , inclined at an angle  $\theta$  to the direction  $OP$ . All the secondary wave travelling in this direction reach the point  $P'$  on the screen. The point  $P'$  will be of maximum or minimum intensity depending on the path difference between the secondary waves originating from the corresponding points of the wavefront. Draw  $OC$  and  $BL$  perpendicular to  $AR$ .

Then, in the  $\triangle ABL$

$$\sin \theta = \frac{AL}{AB} = \frac{AL}{a}$$

or

$$AL = a \sin \theta$$

where  $a$  is the width of the slit and  $AL$  is the path difference between the secondary waves originating from  $A$  and  $B$ . If this path difference is equal to  $\lambda$  the wavelength of light used, then  $P'$  will be a point of minimum intensity. The whole wavefront can be considered to be of two halves  $OA$  and  $OB$  and if the path difference between the secondary waves from  $A$  and  $B$  is  $\lambda$ , then the path difference between the secondary waves from  $A$  and  $O$  will be  $\frac{\lambda}{2}$ . Similarly for every point in the upper half  $OA$ , there is a corresponding point in the lower half  $OB$ , and the path difference between the secondary waves from these points is  $\frac{\lambda}{2}$ . Thus, destructive interference takes place and the point  $P'$  will be of minimum intensity. If the direction of the secondary waves is such that  $AL = 2\lambda$ , then also the point where they meet the screen will be of minimum intensity. This is so, because the secondary waves from the corresponding points of the lower half, differ in path by  $\frac{\lambda}{2}$  and this again gives the position of minimum intensity. In general

$$a \sin \theta_n = n \lambda$$

$$\sin \theta_n = \frac{n \lambda}{a}$$

where  $\theta_n$  gives the direction of the  $n$ th minimum. Here  $n$  is an integer.

If, however, the path difference is odd multiples of  $\frac{\lambda}{2}$ , the directions of the secondary maxima can be obtained. In this case,

$$a \sin \theta_n = (2n + 1) \frac{\lambda}{2}$$

or

$$\sin \theta_n = \frac{(2n + 1) \lambda}{2a}$$

where

$$n = 1, 2, 3 \text{ etc.}$$

Thus, the diffraction pattern due to a single slit consists of a central bright maximum at  $P$  followed by secondary maxima and minima on both the sides. The intensity distribution on the screen is given in Fig. 9.34.

$P$  corresponds to the position of the central bright maximum and the points on the screen for which the path difference between the points  $A$  and  $B$

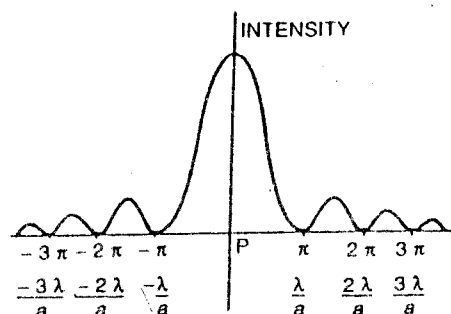

Fig. 9.34

is  $\lambda$ ,  $2\lambda$  etc., correspond to the positions of secondary minima. The secondary maxima are of much less intensity. The intensity falls off rapidly from the point  $P$  outwards.

If the lens  $L_2$  is very near the slit or the screen is far away from the lens  $L_2$ , then

$$\sin \theta = \frac{x}{f} \quad \dots(i)$$

where  $f$  is the focal length of the lens  $L_2$ .

$$\text{But, } \sin \theta = \frac{\lambda}{a} \quad \dots(ii)$$

$$\therefore \frac{x}{f} = \frac{\lambda}{a}$$

$$\text{or } x = \frac{f\lambda}{a}$$

where  $x$  is the distance of the secondary minimum from the point  $P$ . Thus, the width of the central maximum =  $2x$ .

$$\text{or } 2x = \frac{2f\lambda}{a} \quad \dots(iii)$$

The width of the central maximum is proportional to  $\lambda$ , the wavelength of light. With red light (longer wavelength), the width of the central maximum is more than with violet light (shorter wavelength). With a narrow slit, the width of the central maximum is more. The diffraction pattern consists of alternate bright and dark bands with monochromatic light. With white light, the central maximum is white and the rest of the diffraction

bands are coloured. From equation (ii), if the width  $a$  of the slit is large,  $\sin \theta$  is small and hence  $\theta$  is small. The maxima and minima are very close to the central maximum at  $P$ . But with a narrow slit,  $a$  is small and hence  $\theta$  is large. This results a distinct diffraction maxima and minima on both the sides of  $P$ .

**Example 9.9.** Find the half angular width of the central bright maximum in the Fraunhofer diffraction pattern of a slit of width  $12 \times 10^{-5}$  cm when the slit is illuminated by monochromatic light of wavelength  $6000 \text{ \AA}$ .

$$\text{Here } \sin \theta = \frac{\lambda}{a}$$

where  $\theta$  is half angular width of the central maximum.

$$a = 12 \times 10^{-5} \text{ cm}, \lambda = 6000 \text{ \AA} = 6 \times 10^{-5} \text{ cm.}$$

$$\therefore \sin \theta = \frac{\lambda}{a} = \frac{6 \times 10^{-5}}{12 \times 10^{-5}} = 0.50$$

$$\text{or } \theta = 30^\circ$$

**Example 9.10.** In Fraunhofer diffraction due to a narrow slit a screen is placed 2 m away from the lens to obtain the pattern. If the slit width is 0.2 mm and the first minima lie 5 mm on either side of the central maximum, find the wavelength of light. [Delhi (Sub) 1977]

In the case of Fraunhofer diffraction at a narrow rectangular aperture,

$$a \sin \theta = n \lambda$$

$$n = 1$$

$$\therefore a \sin \theta = \lambda$$

$$\sin \theta = \frac{x}{D}$$

$$\therefore \frac{ax}{D} = \lambda$$

$$\lambda = \frac{ax}{D}$$

Here

$$a = 0.2 \text{ mm} = 0.02 \text{ cm}$$

$$x = 5 \text{ mm} = 0.5 \text{ cm}$$

$$D = 2 \text{ m} = 200 \text{ cm}$$

$$\therefore \lambda = \frac{0.02 \times 0.5}{200}$$

$$\lambda = 5 \times 10^{-5} \text{ cm}$$

$$\lambda = 5000 \text{ \AA}$$

at an angle  $\theta$  from the point  $B$  upwards, the path difference changes and hence the phase difference also increases. Let  $\alpha$  be the phase difference between the secondary waves from the points  $B$  and  $A$  of the slit (Fig. 9.27). As the wavefront is divided into a large number of strips, the resultant amplitude due to all the individual small strips can be obtained by the vector polygon method. Here, the amplitudes are small and the phase difference increases by infinitesimally small amounts from strip to strip. Thus, the vibration polygon coincides with the circular arc  $OM$  (Fig. 9.35).  $OP$  gives the direction of the initial vector and  $NM$  the direction of the final vector due to the secondary waves from  $A$ .  $K$  is the centre of the circular arc.

$$\angle MNP = 2\alpha$$

$$\therefore \angle OKM = 2\alpha$$

In the  $\Delta OKL$

$$\sin \alpha = \frac{OL}{r}; OL = r \sin \alpha$$

where  $r$  is the radius of the circular arc

$$\therefore \text{Chord } OM = 2 OL = 2r \sin \alpha \quad \dots (i)$$

The length of the arc  $OM$  is proportional to the width of the slit

$$\therefore \text{Length of the arc } OM = Ka$$

where  $K$  is a constant and  $a$  is the width of the slit.

$$\text{Also, } 2\alpha = \frac{\text{Arc } OM}{\text{radius}} = \frac{Ka}{r}$$

$$\text{or } 2r = \frac{Ka}{\alpha} \quad \dots (ii)$$

Substituting this value of  $2r$  in equation (i)

$$\text{Chord } OM = \frac{Ka}{\alpha} \sin \alpha$$

But,  $OM = A$  where  $A$  is the amplitude of the resultant.

$$\therefore A = (Ka) \frac{\sin \alpha}{\alpha}$$

$$A = A_0 \frac{\sin \alpha}{\alpha} \quad \dots (iii)$$

Thus, the resultant amplitude of vibration at a point on the screen is given by  $A_0 \frac{\sin \alpha}{\alpha}$  and the intensity  $I$  at the point is given by

$$I = A^2 = A_0^2 \frac{\sin^2 \alpha}{\alpha^2} = I_0 \left( \frac{\sin \alpha}{\alpha} \right)^2 \quad \dots (iv)$$

The intensity at any point on the screen is proportional to  $\left( \frac{\sin \alpha}{\alpha} \right)^2$ . A phase difference of  $2\pi$  corresponds to a path difference of  $\lambda$ . Therefore a phase difference of  $2\alpha$  is given by

$$2\alpha = \frac{2\pi}{\lambda} \cdot a \sin \theta \quad \dots (iv)$$

where  $a \sin \theta$  is the path difference between the secondary waves from  $A$  and  $B$  (Fig. 9.35).

$$\alpha = \frac{\pi}{\lambda} \cdot a \sin \theta \quad \dots (v)$$

Thus, the value of  $\alpha$  depends on the angle of diffraction  $\theta$ . The value of  $\frac{\sin^2 \alpha}{\alpha^2}$  for different values of  $\theta$  gives the intensity at the point under consideration. Fig. 9.34 represents the intensity distribution. It is a graph of  $\frac{\sin^2 \alpha}{\alpha^2}$  (along the  $Y$ -axis), as a function of  $\alpha$  or  $\sin \theta$  (along the  $X$ -axis).

#### 9.24 FRAUNHOFER DIFFRACTION AT A SINGLE SLIT (CALCULUS METHOD)

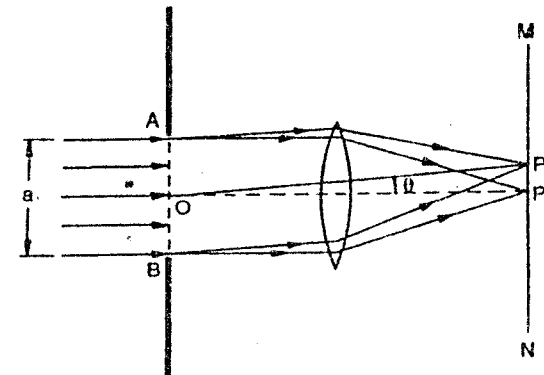

Fig. 9.36

Let a monochromatic parallel beam of light be incident on the slit  $AB$  of width  $a$ . The secondary waves travelling in the same direction as

the incident light come to focus at the point  $P$ . The secondary waves travelling at an angle  $\theta$  come to focus at  $P'$  (Fig. 9.36).

Consider the screen to be at a distance  $r$  from the slit. The centre of the slit  $O$  is the origin of coordinates. Consider a small element  $dz$  of the wavefront with coordinates  $(o, z)$ . The coordinates of the point  $P'$  are  $(x_0, z_0)$  [Fig. 9.37]. The distance of the element from the point  $P'$  is  $\rho$ .

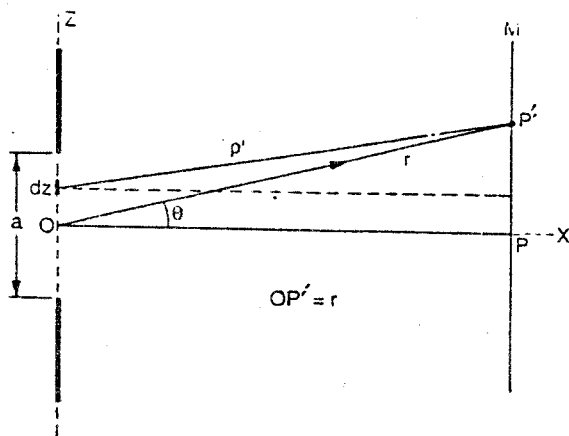

Fig. 9.37

The displacement at the point  $P'$  due to the element  $dz$  at any instant is given by,

$$dy = K dz \sin 2\pi \left( \frac{t}{T} - \frac{\rho}{\lambda} \right) \quad \dots(i)$$

The resultant displacement at  $P'$  due to the whole wavefront,

$$y = K \int_{-\frac{a}{2}}^{+\frac{a}{2}} \sin 2\pi \left( \frac{t}{T} - \frac{\rho}{\lambda} \right) dz \quad \dots(ii)$$

Also  $\rho^2 = x_0^2 + (z_0 - z)^2 \quad \dots(iii)$

$$r^2 = x_0^2 + z_0^2$$

$$x_0^2 = r^2 - z_0^2$$

Substituting the value of  $x_0^2$  in equation (iii)

$$\rho^2 = r^2 - z_0^2 + (z_0 - z)^2$$

$$\rho^2 = r^2 \left[ 1 - \frac{2zz_0}{r^2} + \frac{z^2}{r^2} \right] \quad \dots(iv)$$

In the case of Fraunhofer diffraction, the screen is at a very large distance from the slit, therefore  $r \gg z$  and  $\frac{z^2}{r^2}$  is negligible.

$$\therefore \rho^2 = r^2 \left[ 1 - \frac{2zz_0}{r^2} \right]$$

$$\rho = r \left[ 1 - \frac{zz_0}{r^2} \right]$$

$$\rho = r - \frac{zz_0}{r}$$

But,  $\frac{z_0}{r} = \sin \theta$

$$\therefore \rho = r - z \sin \theta \quad \dots(v)$$

Substituting this value of  $\rho$  in equation (ii)

$$y = K \int_{-\frac{a}{2}}^{+\frac{a}{2}} \sin \left[ 2\pi \left( \frac{t}{T} - \frac{r}{\lambda} + \frac{z \sin \theta}{\lambda} \right) \right] dz$$

$$y = -\frac{K\lambda}{2\pi \sin \theta} \left[ \cos 2\pi \left( \frac{t}{T} - \frac{r}{\lambda} + \frac{a \sin \theta}{2\lambda} \right) - \cos 2\pi \left( \frac{t}{T} - \frac{r}{\lambda} - \frac{a \sin \theta}{2\lambda} \right) \right]$$

$$y = -\frac{K\lambda}{2\pi \sin \theta} \left[ 2 \sin 2\pi \left( \frac{t}{T} - \frac{r}{\lambda} \right) \sin 2\pi \left( -\frac{a \sin \theta}{2\lambda} \right) \right]$$

$$y = \frac{K\lambda}{\pi \sin \theta} \left[ \sin 2\pi \left( \frac{t}{T} - \frac{r}{\lambda} \right) \sin \left( \frac{\pi a \sin \theta}{\lambda} \right) \right]$$

Let  $\frac{\pi a \sin \theta}{\lambda} = \alpha$

$$\therefore y = Ka \left( \frac{\sin \alpha}{\alpha} \right) \sin 2\pi \left( \frac{t}{T} - \frac{r}{\lambda} \right) \quad \dots(vi)$$

The amplitude at  $P'$  is

$$Ka \left( \frac{\sin \alpha}{\alpha} \right) \text{ and the intensity at } P',$$

$$I' = K^2 a^2 \left( \frac{\sin^2 \alpha}{\alpha^2} \right)$$

$$I' = I_0 \left( \frac{\sin^2 \alpha}{\alpha^2} \right) \quad \dots(vii)$$

Here  $I_0 = K^2 a^2$  and is the value of the intensity at  $P$ , for  $\alpha = 0$

$$\frac{\sin \alpha}{\alpha} = 1$$

$$\alpha \rightarrow 0$$

(i) **Central Maximum.** For the point  $P$  on the screen (Fig. 9.27).

$$\theta = 0;$$

and hence  $\alpha = 0;$

The value of  $\frac{\sin \alpha}{\alpha}$  when  $\alpha \rightarrow 0$  is equal to 1. Hence, the intensity

$$\text{at } P = I_0 \left( \frac{\sin \alpha}{\alpha} \right)^2 = I_0 \text{ which is maximum.}$$

(ii) **Secondary Maxima.** The directions of secondary maxima are given by the equation

$$\sin \theta_n = \frac{(2n+1)\lambda}{2a}$$

Substituting this value of  $\theta_n$  in equation (v) (page 457)

$$\alpha = \frac{\pi}{\lambda} \cdot \frac{a(2n+1)\lambda}{2a} = \frac{(2n+1)\pi}{2} \quad \dots(viii)$$

Substituting  $n = 1, 2, 3$  etc. in equation (viii), the values of  $\alpha$  are given by

$$\alpha = \frac{3\pi}{2}, \frac{5\pi}{2}, \frac{7\pi}{2} \text{ etc.}$$

(a) For the first secondary maximum

$$\alpha = \frac{3\pi}{2}$$

and 
$$I = I_0 \left( \frac{\sin \alpha}{\alpha} \right)^2$$

$$= I_0 \left[ \frac{\sin \frac{3\pi}{2}}{\frac{3\pi}{2}} \right]^2 = I_0 \left[ \frac{-1}{\frac{3\pi}{2}} \right]^2 = \frac{4I_0}{9\pi^2}$$

$$= \frac{I_0}{22}$$

(b) For the secondary maximum,

$$\alpha = \frac{5\pi}{2}$$

and 
$$I = I_0 \left( \frac{\sin \alpha}{\alpha} \right)^2$$

$$= I_0 \left[ \frac{\sin \frac{5\pi}{2}}{\frac{5\pi}{2}} \right]^2 = \left[ \frac{1}{\frac{5\pi}{2}} \right]^2 = \frac{4I_0}{25\pi^2}$$

$$= \frac{I_0}{61}$$

Thus, the secondary maxima are of decreasing intensity and the directions of these maxima are obtained from the equation given above.

The intensity at  $P'$  is given by

$$I' = I_0 \left( \frac{\sin^2 \alpha}{\alpha^2} \right)$$



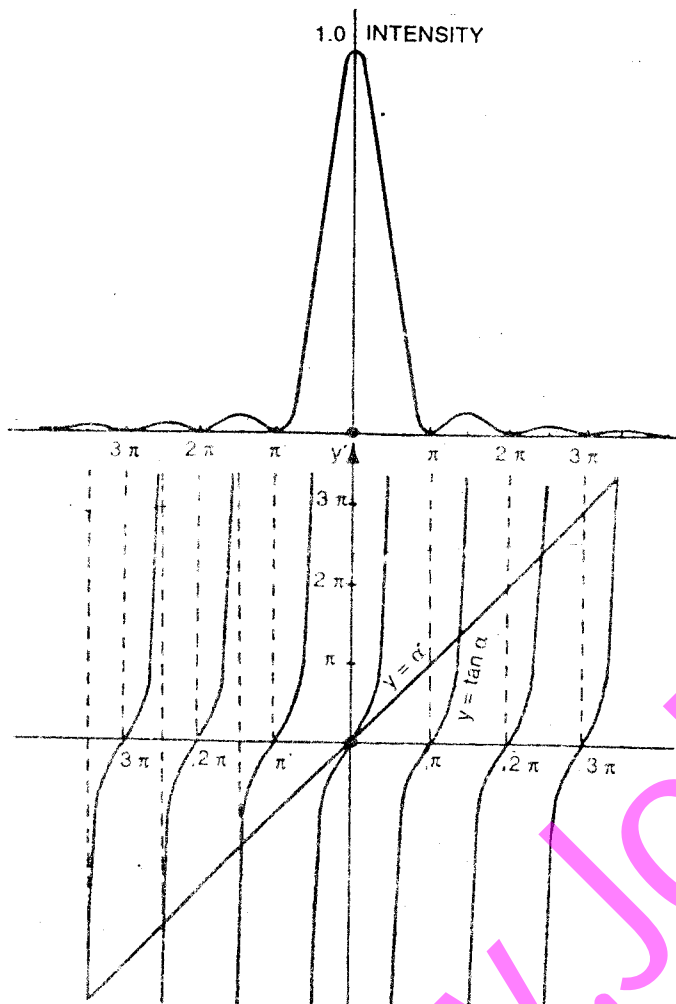

Fig. 9.38

$$dI' = I_0 \left[ \frac{\alpha^2 2 \sin \alpha \cos \alpha - (\sin^2 \alpha) 2\alpha}{\alpha^4} \right] d\alpha$$

For  $I'$  to be maximum

$$\frac{dI'}{d\alpha} = 0$$

$$\therefore \alpha^2 (2 \sin \alpha \cos \alpha) - (\sin^2 \alpha) 2\alpha = 0$$

$$\tan \alpha = \alpha$$

If graphs are plotted for  $y = \alpha$  and  $y = \tan \alpha$  it will be found that the secondary maxima are not exactly midway between two minima. The positions of the secondary maxima are slightly towards the central maximum (Fig. 9.38).

(iii) **Secondary Minima.** The directions of the secondary minima are given by the equation

$$a \sin \theta = n \lambda$$

Substituting the value of  $a \sin \theta$  in equation (v), (page 457)

$$\alpha = \frac{\pi}{\lambda} n \lambda = n\pi \quad (ix)$$

Substituting  $n = 1, 2, 3$  etc. in equation (ix),

$$\alpha = \pi, 2\pi, 3\pi \text{ etc.}$$

When these values of  $\alpha$  are substituted in the equation for the intensity viz.

$$I = I_0 \left( \frac{\sin \alpha}{\alpha} \right)^2; \quad I = 0$$

In Fig. 9.34, the positions of the secondary minima are shown for the values of

$$\alpha = \pi, 2\pi, 3\pi \text{ etc.}$$

$\frac{\lambda}{a}, \frac{2\lambda}{a}, \frac{3\lambda}{a}$  etc. refer to the values of  $\sin \theta$  for these positions.

### 9.25 FRAUNHOFER DIFFRACTION AT A CIRCULAR APERTURE

In Fig. 9.39,  $AB$  is a circular aperture of diameter  $d$ .  $C$  is the centre

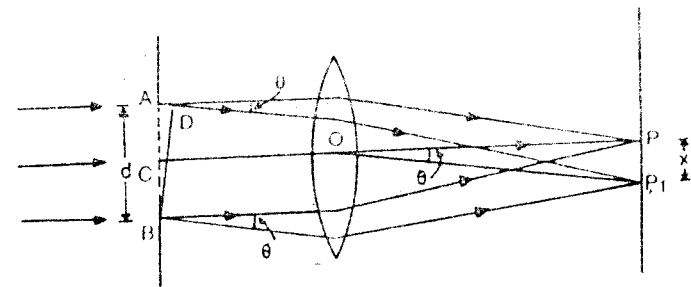

Fig. 9.39

of the aperture and  $P$  is a point on the screen.  $CP$  is perpendicular to the screen. The screen is perpendicular to the plane of the paper. A plane wavefront is incident on the circular aperture. The secondary waves travelling in the direction  $CO$  come to focus at  $P$ . Therefore,  $P$  corresponds to the position of the central maximum. Here, all the secondary waves emanating from points equidistant from  $O$  travel the same distance before reaching  $P$  and hence they all reinforce one another. Now consider the secondary waves travelling in a direction inclined at an angle  $\theta$  with the direction  $CP$ . All these secondary waves meet at  $P_1$  on the screen. Let the distance  $PP_1$  be  $x$ . The path difference between the secondary waves emanating from the points  $B$  and  $A$  (extremities of a diameter) is  $AD$ .

From the  $\triangle ABD$ ,

$$AD = d \sin \theta$$

Arguing as in Article 9.22, the point  $P_1$  will be of minimum intensity if this path difference is equal to integral multiples of  $\lambda$  i.e.,

$$d \sin \theta_n = n\lambda \quad \dots(i)$$

The point  $P_1$  will be of maximum intensity if the path difference is equal to odd multiples of  $\frac{\lambda}{2}$  i.e.,

$$d \sin \theta_n = \frac{(2n+1)\lambda}{2} \quad \dots(ii)$$

If  $P_1$  is a point of minimum intensity, then all the points at the same distance from  $P$  as  $P_1$  and lying on a circle of radius  $x$  will be of minimum intensity. Thus, the diffraction pattern due to a circular aperture consists of a central bright disc called the Airy's disc, surrounded by alternate dark and bright concentric rings called the Airy's rings. The intensity of the dark rings is zero and that of the bright rings decreases gradually outwards from  $P$ .

Further, if the collecting lens is very near the slit or when the screen is at a large distance from the lens,

$$\sin \theta = \theta = \frac{x}{f} \quad \dots(iii)$$

Also, for the first secondary minimum,

$$d \sin \theta = \lambda$$

$$\sin \theta = \theta = \frac{\lambda}{d} \quad \dots(iv)$$

From equations (iii) and (iv)

$$\frac{x}{f} = \frac{\lambda}{d}$$

or

$$x = \frac{f\lambda}{d} \quad \dots(v)$$

where  $x$  is the radius of the Airy's disc. But actually, the radius of the first dark ring is slightly more than that given by equation (v). According to Airy, it is given by

$$x = \frac{1.22 f\lambda}{d} \quad \dots(vi)$$

The discussion of the intensity distribution of the bright and dark rings is similar to the one given for a rectangular slit. With increase in the diameter of the aperture, the radius of the central bright ring decreases.

**Example 9.16.** In Fraunhofer diffraction pattern due to a single slit, the screen is at a distance of 100 cm from the slit and the slit is illuminated by monochromatic light of wavelength 5893 Å. The width of the slit is 0.1 mm. Calculate the separation between the central maximum and the first secondary minimum. (Mysore)

For a rectangular slit,

$$x = \frac{f\lambda}{d}$$

Here

$$f = 100 \text{ cm}, \lambda = 5893 \text{ Å}$$

$$= 5893 \times 10^{-8} \text{ cm},$$

$$d = 0.1 \text{ mm} = 0.01 \text{ cm}, x = ?$$

$$\therefore x = \frac{100 \times 5893 \times 10^{-8}}{0.01} = 0.5893 \text{ cm}$$

## 9.26 FRAUNHOFER DIFFRACTION AT DOUBLE SLIT

In Fig. 9.40,  $AB$  and  $CD$  are two rectangular slits parallel to one another and perpendicular to the plane of the paper. The width of each slit is  $a$  and the width of the opaque portion is  $b$ .  $L$  is a collecting lens and  $MN$  is a screen perpendicular to the plane of the paper.  $P$  is a point on the screen such that  $OP$  is perpendicular to the screen. Let a plane wavefront be incident on the surface of  $XY$ . All the secondary waves travelling in a direction parallel to  $OP$  come to focus at  $P$ . Therefore,  $P$  corresponds to the position of the central bright maximum.

## POLARIZATION

### 10.1 INTRODUCTION

Experiments on interference and diffraction have shown that light is a form of wave motion. These effects do not tell us about the type of wave motion *i.e.*, whether the light waves are longitudinal or transverse, or whether the vibrations are linear, circular or torsional. The phenomenon of polarization has helped to establish beyond doubt that light waves are transverse waves.

### 10.2 POLARIZATION OF TRANSVERSE WAVES

Let a rope  $AB$  be passed through two parallel slits  $S_1$  and  $S_2$ . The rope is attached to a fixed point at  $B$  [Fig. 10.1(a)]. Hold the end  $A$  and

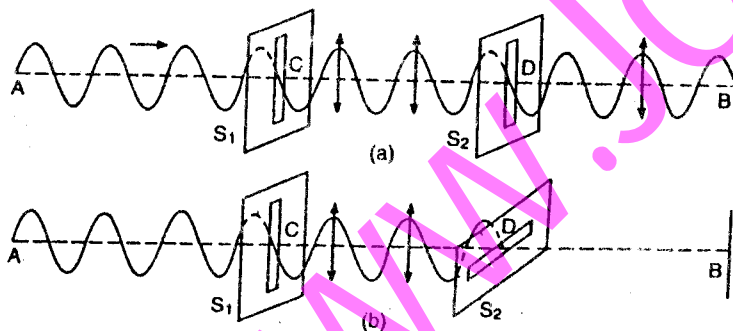

Fig. 10.1

move the rope up and down perpendicular to  $AB$ . A wave emerges along  $CD$  and it is due to transverse vibrations parallel to the slit  $S_1$ . The slit  $S_2$  allows the wave to pass through it when it is parallel to  $S_1$ . It is observed that the slit  $S_2$  does not allow the wave to pass through it when it is at right angles to the slit  $S_1$  [Fig. 10.1(b)].

If the end  $A$  is moved in a circular manner, the rope will show circular motion up to the slit  $S_1$ . Beyond  $S_1$ , it will show only linear vibrations parallel to the slit  $S_1$ , because the slit  $S_1$  will stop the other components. If  $S_1$  and  $S_2$  are at right angles to each other the rope will not show any vibration beyond  $S_2$ .

If longitudinal waves are set up by moving the rope forward and backward along the string, the waves will pass through  $S_1$  and  $S_2$  irrespective of their position.

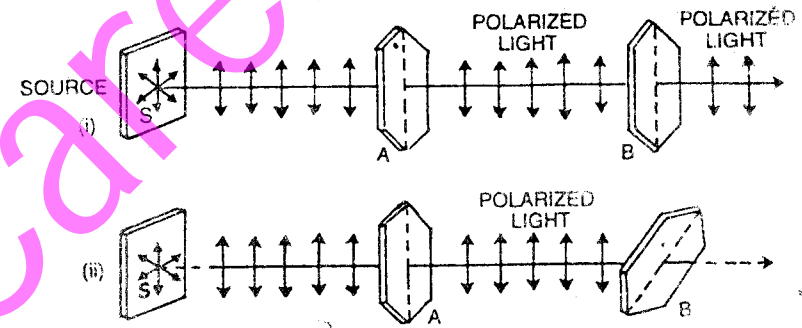

Fig. 10.2

A similar phenomenon has been observed in light when it passes through a tourmaline crystal.

Let light from a source  $S$  fall on a tourmaline crystal  $A$  which is cut parallel to its axis (Fig. 10.2). The crystal  $A$  will act as the slit  $S_1$ . The light is slightly coloured due to the natural colour of the crystal. On rotating the crystal  $A$ , no remarkable change is noticed. Now place the crystal  $B$  parallel to  $A$ .

(1) Rotate both the crystals together so that their axes are always parallel. No change is observed in the light coming out of  $B$  [Fig. 10.2 (i)].

(2) Keep the crystal  $A$  fixed and rotate the crystal  $B$ . The light transmitted through  $B$  becomes dimmer and dimmer. When  $B$  is at right angles to  $A$ , no light emerges out of  $B$  [Fig. 10.2 (ii)].

If the crystal  $B$  is further rotated, the intensity of light coming out of it gradually increases and is maximum again when the two crystals are parallel.

This experiment shows conclusively that light is not propagated as longitudinal or compressional waves. If we consider the propagation of light as a longitudinal wave motion then no extinction of light should occur when the crystal  $B$  is rotated.

It is clear that after passing through the crystal *A*, the light waves vibrate only in one direction. Therefore light coming out of the crystal *A* is said to be **polarized** because it has acquired the property of **one sidedness** with regard to the direction of the rays.

This experiment proves that light waves are transverse waves, otherwise light coming out of *B* could never be extinguished by simply rotating the crystal *B*.

### 10.3 PLANE OF POLARIZATION

When ordinary light is passed through a tourmaline crystal, the light is polarized and vibrations are confined to only one direction perpendicular to the direction of propagation of light. This is plane polarized light and

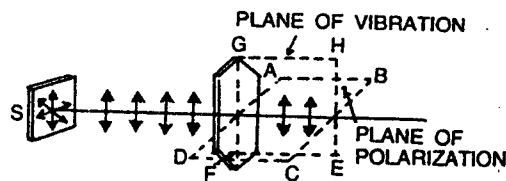

Fig. 10.3

it has acquired the property of one sidedness. The plane of polarization is that plane in which no vibrations occur. The plane *ABCD* in Fig. 10.3 is the plane of polarization. The vibrations occur at right angles to the plane of polarization and the plane in which vibrations occur is known as plane of vibration. The plane *EFGH* in Fig. 10.3 is the plane of vibration.

Ordinary light from a source has very large number of wavelengths.

Moreover, the vibrations may be linear, circular or elliptical. From our idea of wave motion, circular or elliptical vibrations consist of two linear vibrations at right angles to each other and having

a phase difference of  $\frac{\pi}{2}$ .

Therefore any vibration can be resolved into two component vibrations at right angles to each other. As light waves are transverse waves the vibrations can be resolved into two planes *xx'* and *yy'*

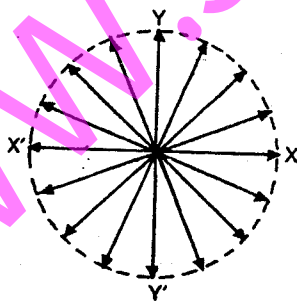

Fig. 10.4

at right angles to each other and also perpendicular to the direction of propagation of light (Fig. 10.4).

In Fig. 10.5(i), the vibrations of the particles are represented parallel (arrow heads) and perpendicular to the plane of the paper (dots).

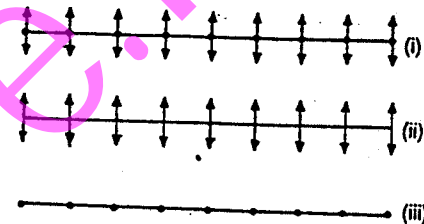

Fig. 10.5

In Fig. (10.3) (ii) the vibrations are shown only parallel to the plane of the paper. In Fig. (10.5) (iii) the vibrations are represented only perpendicular to the plane of the paper.

### 10.4 POLARIZATION BY REFLECTION

Polarization of light by reflection from the surface of glass was discovered by Malus in 1808. He found that polarized light is obtained when ordinary light is reflected by a plane sheet of glass. Consider the light incident along the path *AB* on the glass surface (Fig. 10.6). Light is

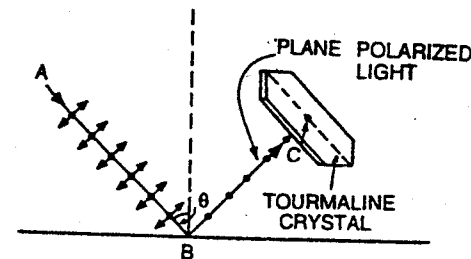

Fig. 10.6

reflected along *BC*. In the path of *BC*, place a tourmaline crystal and rotate it slowly. It will be observed that light is completely extinguished only at one particular angle of incidence. This angle of incidence is equal to  $57.5^\circ$  for a glass surface and is known as the polarizing angle. Similarly polarized light by reflection can be produced from water surface also.

The production of polarized light by glass is explained as follows. The vibrations of the incident light can be resolved into components parallel to the glass surface and perpendicular to the glass surface. Light due to the components parallel to the glass surface is reflected whereas light due to the components perpendicular to the glass surface is transmitted.

Thus, the light reflected by glass is plane polarized and can be detected by a tourmaline crystal.

The polarized light has been analysed by using another mirror by Biot.

### 10.5 BIOTS POLARISCOPE

It consists of two glass plates  $M_1$  and  $M_2$  (Fig. 10.7). The glass plates are painted black on their back surfaces so as to avoid any reflection and this also helps in absorbing refracted light. A beam of unpolarized light  $AB$  is incident at an angle of about  $57.5^\circ$  on the first glass surface at  $B$  and is reflected along  $BC$  (Fig. 10.8). This light is again reflected at  $57.5^\circ$  by the second glass plate  $M_2$  placed parallel to the first. The glass plate  $M_1$  is known as the polarizer and  $M_2$  as the analyser.

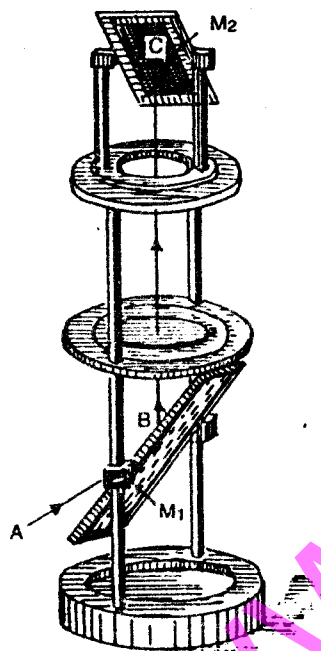

Fig. 10.7

The above experiment proves that when light is incident at an angle of  $57.5^\circ$  on a glass surface, the reflected light consists of waves in which

When the upper plate  $M_2$  is rotated about  $BC$ , the intensity of the reflected beam along  $CD$  decreases and becomes zero for  $90^\circ$  rotation of  $M_2$ . Remember, the rotation of the plate  $M_2$  about  $BC$ , keeps the angle of incidence constant and it does not change with the rotation of  $M_2$ . Thus we find that light travelling along  $BC$  is plane polarized.

When the mirror  $M_2$  is rotated further it is found that the intensity of  $CD$  becomes maximum at  $180^\circ$ , minimum at  $270^\circ$  and again maximum at  $360^\circ$ .

the displacements are confined to a certain direction at right angles to the ray and we get polarized light by reflection.

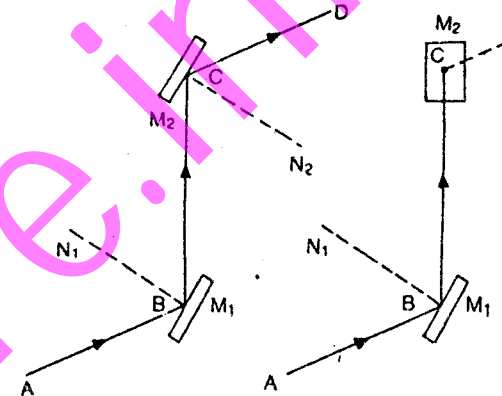

Fig. 10.8

### 10.6 BREWSTER'S LAW

In 1811, Brewster performed a number of experiments to study the polarization of light by reflection at the surfaces of different media.

He found that ordinary light is completely polarized in the plane of incidence when it gets reflected from a transparent medium at a particular angle known as the **angle of polarization**.

He was able to prove that the tangent of the angle of polarization is numerically equal to the refractive index of the medium. Moreover, the reflected and the refracted rays are perpendicular to each other.

Suppose, unpolarized light is incident at an angle equal to the polarizing angle on the glass surface. It is reflected along  $BC$  and refracted along  $BD$  (Fig. 10.9).

From Snell's law

$$\mu = \frac{\sin i}{\sin r} \quad \dots(i)$$

From Brewster's law

$$\mu = \tan i = \frac{\sin i}{\cos i} \quad \dots(ii)$$

Comparing (i) and (ii)

$$\cos i = \sin r = \cos \left( \frac{\pi}{2} - r \right)$$

$$\therefore i = \frac{\pi}{2} - r, \text{ or } i + r = \frac{\pi}{2}$$

As  $i + r = \frac{\pi}{2}$ ,  $\angle CBD$  is also equal to  $\frac{\pi}{2}$ . Therefore, the reflected and the refracted rays are at right angles to each other.

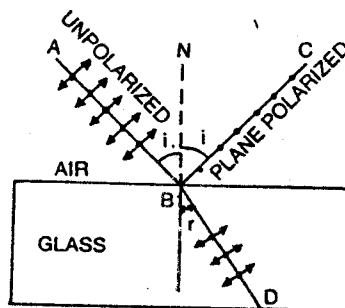

Fig. 10.9

From Brewster's law, it is clear that for crown glass of refractive index 1.52, the value of  $i$  is given by

$$i = \tan^{-1}(1.52) \text{ or } i = 56.7^\circ$$

However,  $57^\circ$  is an approximate value for the polarizing angle for ordinary glass. For a refractive index of 1.7 the polarising angle is about  $59.5^\circ$  i.e., the polarizing angle is not widely different for different glasses.

As the refractive index of a substance varies with the wavelength of the incident light, the polarizing angle will be different for light of different wavelengths. Therefore, polarization will be complete only for light of a particular wavelength at a time i.e., for monochromatic light.

It is clear that the light vibrating in the plane of incidence is not reflected along  $BC$  [Fig. 10.9]. In the reflected beam the vibrations along  $BC$  cannot be observed, whereas vibrations at right angles to the plane of incidence can contribute for the resultant intensity. Thus, we get plane polarized light along  $BC$ . The refracted ray will have both the vibrations (i) in the plane of incidence and (ii) at right angles to the plane of incidence. But it is richer in vibrations in the plane of incidence. Hence it is partially plane-polarized.

### 10.7 BREWSTER WINDOW

One of the important applications of Brewster's law and Brewster's angle is in the design of a glass window that enables 100% transmission of light. Such a type of window is used in lasers and it is called a **Brewster window**,

When an ordinary beam of light is incident normally on a glass window, about 8% of light is lost by reflection on its two surfaces and about 92% intensity is transmitted. In the case of a gas laser filled with mirrors outside the windows, light travels through the window about a hundred times. In this way the intensity of the final beam is about  $3 \times 10^{-4}$  because  $(0.92)^{100} \approx 3 \times 10^{-4}$ . It means the transmitted beam has practically no intensity.

To overcome this difficulty, the window is tilted so that the light beam is incident at Brewster's angle. After about hundred transmissions, the final beam will be plane polarized.

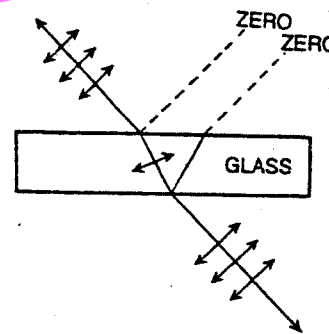

Fig. 10.10

The light component vibrating at right angles to the plane of incidence is reflected. After about 100 reflections at the Brewster window, the transmitted beam will have 50% of the intensity of the incident beam and it will be completely plane polarized. The net effect of this type of arrangement is that half the amount of light intensity has been discarded and the other half is completely retained. Brewster's windows are used in gas lasers.

### 10.8 POLARIZATION BY REFRACTION

It is found that at a single glass surface or any similar transparent medium, only a small fraction of the incident light is reflected.

For glass ( $\mu = 1.5$ ) at the polarizing angle, 100% of the light vibrating parallel to the plane of incidence is transmitted whereas for the perpendicular vibrations only 85% is transmitted and 15% is reflected. Therefore, if we use a **pile of plates** and the beam of ordinary light is incident at the polarizing angle on the pile of plates, some of the vibrations perpendicular to the plane of incidence are reflected by the first plate and the rest are transmitted through it. When this beam of light is reflected by the second plate, again some of the vibrations perpendicular to the

plane of incidence are reflected by it and the rest are transmitted. The process continues and when the beam has traversed about 15 or 20 plates, the transmitted light is completely free from the vibrations at right angles to the plane of incidence and is having vibrations only in the plane of incidence. Thus, we get plane-polarized light by refraction with the help of a pile of plates, the vibrations being in the plane of incidence as shown in Fig. 10.11.

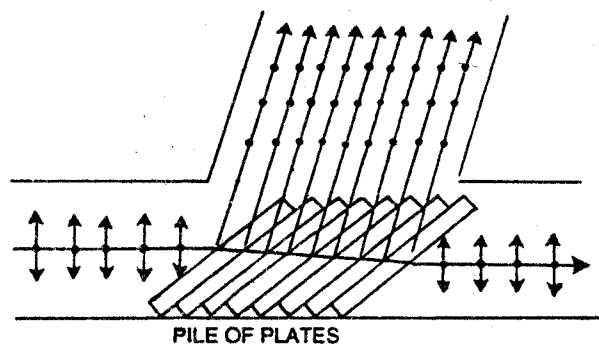

Fig. 10.11

The pile of plates consists of number of glass plates (microscope cover slips) and are supported in a tube of suitable size and are inclined at an angle of  $32.5^\circ$  to the axis of the tube. A beam of monochromatic light is allowed to fall on the pile of plates at the polarizing angle. The transmitted light is polarized perpendicular to the plane of incidence and can be examined by a similar pile of plates which works as an analyser.

**Note.** (i) If light is polarized perpendicular to the plane of incidence, it means vibrations are in the plane of incidence.

(ii) If light is polarized in the plane of incidence, it means vibrations are perpendicular to the plane of incidence.

### 10.9 MALUS LAW

When a beam of light, polarized by reflection at one plane surface is allowed to fall on the second plane surface at the polarizing angle the intensity of the twice reflected beam varies with the angle between the planes of the two surfaces. In the Biot's polariscope it was found that the intensity of the twice reflected beam is maximum when the two planes are parallel and zero when the two planes are at right angles to each other. The same is also true for the twice transmitted beam from the polarizer

and analyser. The law of Malus states that the intensity of the polarized light transmitted through the analyser varies as the square of the cosine of the angle between the plane of transmission of the analyser and the plane of the polarizer. In the case of the Biot's polariscope this angle is between the two reflecting planes.

The proof of the law is based on the fact that any polarized vibration may be resolved into two rectangular components : (i) parallel to the plane of transmission of the analyser (ii) at right angles to it.

Let  $OP = a$  be the amplitude of the vibrations transmitted or reflected by the polarizer and  $\theta$  is the angle between the planes of the polarizer and the analyser (Fig. 10.12).

- Resolve  $OP$  into two components,
- (i)  $a \cos \theta$  along  $OA$  and
- (ii)  $a \sin \theta$  along  $OB$ .

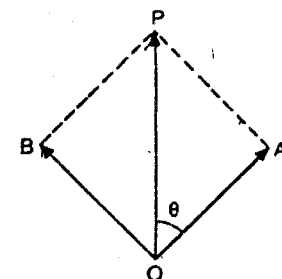

Fig. 10.12

Only the  $a \cos \theta$  component is transmitted through the analyser.

$\therefore$  Intensity of the transmitted light through the analyser

$$E_1 = (a \cos \theta)^2 = a^2 \cos^2 \theta.$$

But  $E = a^2$

where  $E$  is the intensity of incident polarized light

$$\therefore E_1 = E \cos^2 \theta, \text{ and } E_1 \propto \cos^2 \theta$$

When  $\theta = 0$  i.e., the two planes are parallel

$$E_1 = E, \text{ because } \cos 0 = 1$$

When  $\theta = \frac{\pi}{2}$  the two planes are at right angles to each other

$$\therefore E_1 = E \left( \cos \frac{\pi}{2} \right)^2 = 0.$$

**Example 10.1** If the plane of vibration of the incident beam makes an angle of  $30^\circ$  with the optic axis, compare the intensities of extraordinary and ordinary light.

Intensity of the extraordinary ray

$$I_E = A^2 \cos^2 \theta$$

Intensity of the ordinary ray

$$I_o = A^2 \sin^2 \theta$$

$$\frac{I_E}{I_o} = \frac{A^2 \cos^2 \theta}{A^2 \sin^2 \theta} = \frac{\cos^2 \theta}{\sin^2 \theta}$$

Here  $\theta = 30^\circ$

$$\therefore E = \frac{I_E}{I_o} = 3$$

### 10.10 DOUBLE REFRACTION

Erasmus Bartholinus discovered, in 1669, that when a ray of light is refracted by a crystal of calcite it gives two refracted rays. This phenomenon is called **double refraction**. Calcite or Iceland spar is crystallised calcium carbonate ( $\text{CaCO}_3$ ) and was found in large quantities in Iceland as very large transparent crystals. Due to this reason calcite is also known as Iceland spar. It crystallises in many forms and can be reduced by cleavage or breakage into a rhombohedron, bounded by six parallelograms with angles equal to  $102^\circ$  and  $78^\circ$  (more accurately  $101^\circ 55'$  and  $78^\circ 5'$ ).

✓ **Optic Axis.** At two opposite corners  $A$  and  $H$ , of the rhombohedron all the angles of the faces are obtuse [Fig. 10.13 (a)]. These corners  $A$  and  $H$  are known as the blunt corners of the crystal. A line drawn through  $A$  making equal angles with each of the three edges gives the direction of the optic axis. In fact any line parallel to this line is also an optic axis. Therefore, optic axis is not a line but it is a direction. Moreover, it is not defined by joining the two blunt corners. Only in a special case, when the three edges of the crystal are equal, the line joining the two blunt corners  $A$  and  $H$  coincides with the crystallographic axis of the crystal and it gives the direction of the optic axis [Fig. 10.13 (b)]. If a ray of light is incident along the optic axis or in a direction parallel to the optic axis, then

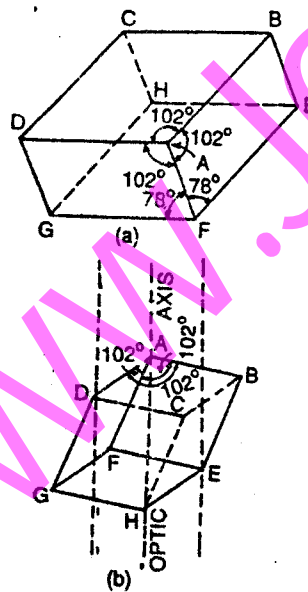

Fig. 10.13

it will not split into two rays. Thus, the phenomenon of double refraction is absent when light is allowed to enter the crystal along the optic axis.

The phenomenon of double refraction can be shown with the help of the following experiment :

Mark an ink dot on a piece of paper. Place a calcite crystal over this dot on the paper. Two images will be observed. Now rotate the crystal

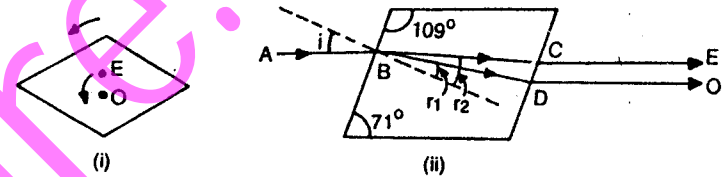

Fig. 10.14

slowly as shown in Fig. 10.14 (i). Place your eye vertically above the crystal. It is found that one image remains stationary and the second image rotates with the rotation of the crystal. The stationary image is known as the ordinary image while the second one is known as the extraordinary image.

When a ray of light  $AB$  is incident on the calcite crystal making an angle of incidence  $= i$ , it is refracted along two paths inside the crystal, (i) along  $BC$  making an angle of refraction  $= r_2$  and (ii) along  $BD$  making an angle of refraction  $= r_1$ . These two rays emerge out along  $DO$  and  $CE$  which are parallel [Fig. 10.14 (ii)].

The ordinary ray has a refractive index  $\mu_o = \frac{\sin i}{\sin r_1}$  and the extraordinary ray has a refractive index  $\mu_e = \frac{\sin i}{\sin r_2}$ . It is found that the ordinary

ray obeys the laws of refraction and its refractive index is constant. In the case of the extraordinary ray, its refractive index varies with the angle of incidence and it is not fixed.

In the case of calcite  $\mu_o > \mu_e$  because  $r_1$  is less than  $r_2$  [Fig. 10.14 (ii)]. Therefore the **velocity of light for the ordinary ray inside the crystal will be less** compared to the velocity of light for the extraordinary ray. In calcite, the extraordinary ray travels faster as compared to the ordinary ray. Moreover, the velocity of the extraordinary ray is different in different directions because its refractive index varies with the angle of incidence.



It has been found that both the rays are plane polarized. The vibrations of the ordinary ray are perpendicular to the principal section of the crystal while the vibrations of the extraordinary ray are in the plane of the principal section of the crystal. Thus, the two rays are **plane polarised**, their vibrations being at right angles to each other.

**Special Cases.** (1) It should be remembered that a ray of light is not split up into ordinary and extraordinary components when it is incident on calcite parallel to its optic axis. In this case, the ordinary and the extraordinary rays travel along the same direction with the same velocity.

(2) When a ray of light is incident perpendicular to the optic axis on the calcite crystal, the ray of light is not split up into ordinary and extraordinary components. It means that the ordinary and the extraordinary rays travel in the same direction but with **different velocities**.

### 10.11 PRINCIPAL SECTION OF THE CRYSTAL

A plane which contains the optic axis and is perpendicular to the opposite faces of the crystal is called the **principal section** of the crystal. As a crystal has six faces, therefore, for every point there are three principal sections. A principal section always cuts the surface of a calcite crystal in a parallelogram with angles  $109^\circ$  and  $71^\circ$ .

### 10.12 PRINCIPAL PLANE

A plane in the crystal drawn through the optic axis and the ordinary ray is defined as the principal plane of the ordinary ray. Similarly, a plane in the crystal drawn through the optic axis and the extraordinary ray is defined as the principal plane of the extraordinary ray. In general, the two planes do not coincide. In a particular case, when the plane of incidence is a principal section then the principal section of the crystal and the principal planes of the ordinary and the extraordinary rays coincide.

### 10.13 NICOL PRISM

It is an optical device used for producing and analysing plane polarized light. It was invented by William Nicol, in 1828, who was an expert in cutting and polishing gems and crystals. We have discussed that when a beam of light is transmitted through a calcite crystal, it breaks up into two rays : (1) the ordinary ray which has its vibrations perpendicular to the principal section of the crystal and (2) the extraordinary ray which has its vibrations parallel to the principal section.

The **nicol prism** is made in such a way that it eliminates one of the two rays by **total internal reflection**. It is generally found that the ordinary ray is eliminated and, only the extraordinary ray is transmitted through the prism.

A calcite crystal whose length is three times its breadth is taken. Let  $A'BCDEFG'H$  represent such a crystal having  $A'$  and  $G'$  as its blunt corners and  $A'CG'E$  is one of the principal sections with  $\angle A'CG' = 70^\circ$ .

The faces  $A'BCD$  and  $EFG'H$  are ground in such a way that the angle  $\angle ACG$  becomes  $= 68^\circ$  instead of  $71^\circ$ . The crystal is then cut along the plane  $AKGL$  as shown in Fig. 10.15. The two cut surfaces are grounded and polished optically flat and then cemented together by Canada balsam whose refractive index lies between the refractive indices for the ordinary and the extraordinary rays for calcite.

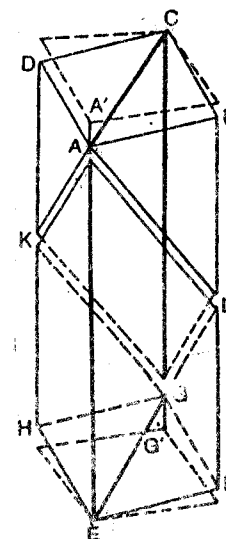

Fig. 10.15

Refractive index for the ordinary

$$\mu_o = 1.658$$

Refractive index for Canada balsam

$$\mu_b = 1.55$$

Refractive index for the extraordinary  $\mu_e = 1.486$

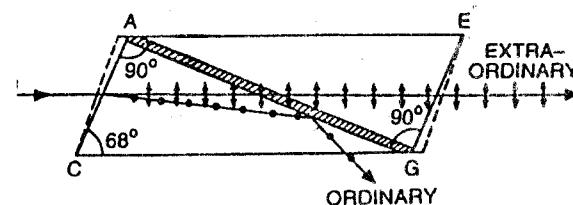

Fig. 10.16

In Fig. 10.16, the section  $ACGE$  of the crystal is shown. The diagonal  $AC$  represents the Canada balsam layer in the plane  $ALGK$  of Fig. 10.15.

It is clear that Canada balsam acts as a rarer medium for an ordinary ray and it acts as a denser medium for the extraordinary ray. Therefore, when the ordinary ray passes from a portion of the crystal into the layer of Canada balsam it passes from a denser to a rarer medium. When the angle of incidence is greater than the critical angle, the ray is totally internally reflected and is not transmitted. The extraordinary ray is not

affected and is therefore transmitted through the prism. The working of the prism is clear from the following cases :-

(1) Refractive index for ordinary ray with respect to Canada balsam

$$= \mu = \frac{1.658}{1.550}$$

$$\therefore \sin \theta = \frac{1}{\mu} = \frac{1.550}{1.658}$$

$$\therefore \theta = 69^\circ$$

If the angle of incidence for the ordinary ray is more than the critical angle, it is totally internally reflected and only the extraordinary ray passes through the nicol prism. Therefore, a ray of unpolarized light on passing through the nicol prism in this position becomes plane-polarized.

(2) If the angle of incidence is less than the critical angle for the ordinary ray, it is not reflected and is transmitted through the prism. In this position both the ordinary and the extraordinary rays are transmitted through the prism.

(3) The extraordinary ray also has a limit beyond which it is totally internally reflected by the Canada balsam surface. The refractive index for the extraordinary ray = 1.486 when the extraordinary ray is travelling at right angles to the direction of the optic axis. If the extraordinary ray travels along the optic axis, its refractive index is the same as that of the ordinary ray and it is equal to 1.658. Therefore, depending upon the direction of propagation of the extraordinary ray  $\mu_e$  lies between 1.486 and 1.658. Therefore for a particular case  $\mu_e$  may be more than 1.55 and the angle of incidence will be more than the critical angle. Then, the extraordinary ray will also be totally internally reflected at the Canada balsam layer. The sides of the nicol prism are coated with black paint to absorb the ordinary rays that are reflected towards the sides by the Canada balsam layer.

#### ✓ 10.14 NICOL PRISM AS AN ANALYSER

Nicol prism can be used for the production and detection of plane-polarizer light.

When two nicol prisms  $P_1$  and  $P_2$  are placed adjacent to each other as shown in Fig. 10.17 (i), one of them acts as a polarizer and the other acts as an analyser. Fig. 10.17 (i) shows the position of two parallel nicols and only the extraordinary ray passes through both the prisms.

If the second prism  $P_2$  is gradually rotated, the intensity of the extraordinary ray decreases in accordance with Malus Law and when

the two prisms are crossed [i.e., when they are at right angles to each other, Fig. 10.16 (ii)], then no light comes out of the second prism  $P_2$ . It means that light coming out of  $P_1$  is plane polarized. When the polarized extraordinary ray enters the prism  $P_2$  in this positions it acts as

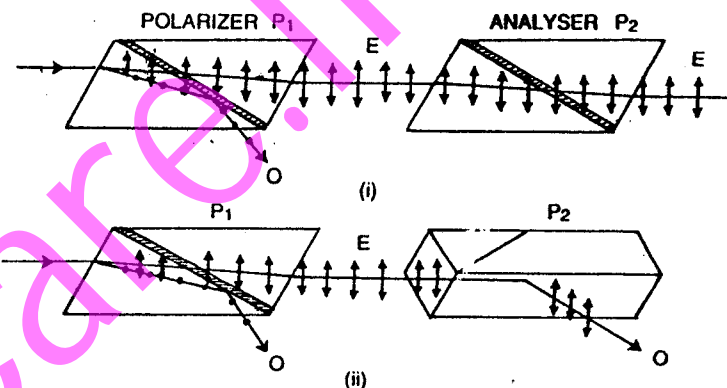

Fig. 10.17

an ordinary ray and is totally internally reflected by the Canada balsam layer and so no light comes out of  $P_2$ . Therefore, the prism  $P_1$  produces plane-polarized light and the prism  $P_2$  detects it.

Hence  $P_1$  and  $P_2$  are called the polarizer and the analyser respectively. The combination of  $P_1$  and  $P_2$  is called a polariscope.

#### ✓ 10.15 HUYGENS EXPLANATION OF DOUBLE REFRACTION IN UNIAXIAL CRYSTALS

Huygens explained the phenomenon of double refraction with the help of his principle of secondary wavelets. A point source of light in a double refracting medium is the origin of two wavefronts. For the ordinary ray, for which the velocity of light is the same in all directions the wavefront is spherical. For the extraordinary ray, the velocity varies with the direction and the wavefront is an ellipsoid of revolution. **The velocities of the ordinary and the extraordinary rays are the same along the optic axis.**

Consider a point source of light  $S$  in a calcite crystal [Fig. 10.18 (a)]. The sphere is the wave surface for the ordinary ray and the ellipsoid is the wave surface for the extraordinary ray. The ordinary wave surface lies within the extraordinary wave surface. Such crystals are known as **negative crystals**. For crystals like quartz, which are known as positive crystals,

the extraordinary wave surface lies within the ordinary wave surface [Fig. 10.18 (b)].

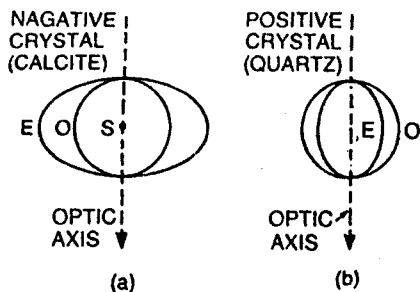

Fig. 10.18

(1) For the **negative uniaxial** crystals,  $\mu_o > \mu_e$ . The velocity of the extraordinary ray varies as the radius vector of the ellipsoid. It is least and equal to the velocity of the ordinary ray along the optic axis but it is maximum at right angles to the direction of the optic axis.

(2) For the **positive uniaxial** crystals  $\mu_e > \mu_o$ . The velocity of the extraordinary ray is least in a direction at right angles to the optic axis. It is maximum and is equal to the velocity of the ordinary ray along the optic axis. Hence, from Huygens' theory, the wavefronts or surfaces in uniaxial crystals are a sphere and an ellipsoid and there are two points where these two wavefronts touch each other. The direction of the line joining these two points (Where the sphere and the ellipsoid touch each other) is the optic axis.

### 10.16 OPTIC AXIS IN THE PLANE OF INCIDENCE AND INCLINED TO THE CRYSTAL SURFACE

(a) **Oblique incidence.**  $AB$  is the incident plane wavefront of the rays falling obliquely on the surface  $MN$  of the negative crystal. The crystal is cut so that the optic axis is in the plane of incidence and is in the direction shown in Fig. 10.19.  $O_1$  is the spherical secondary wavefront for the ordinary ray and  $E_1$  is the ellipsoidal secondary wavefront for the extraordinary ray.  $CP$  is the tangent meeting the spherical wavefront at  $P$  and  $CQ$  is the tangent meeting the ellipsoidal wavefront at  $Q$ .

According to Huygens' construction, by the time the incident wave reaches from  $B$  to  $C$ , the ordinary ray travels the distance  $AP$  and the extraordinary ray travels the distance  $AQ$ . Suppose, the velocity of light

in air is  $V_a$  and the velocities of light for the ordinary ray along  $AP$  and the extraordinary ray along  $AQ$  are  $V_o$  and  $V_e$  respectively. In this case,

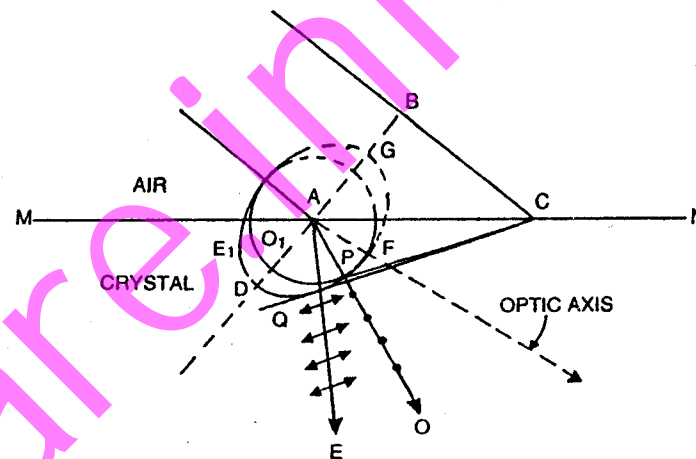

Fig. 10.19

$$\frac{BC}{V_a} = \frac{AP}{V_o} = \frac{AQ}{V_e} \quad \dots(i)$$

$$\text{Therefore } AP = \frac{BC \cdot V_o}{V_a} = \frac{BC}{\mu_o} \quad \dots(ii)$$

$$\text{and } AQ = \frac{BC \cdot V_e}{V_a} = \frac{BC}{\mu_e} \quad \dots(iii)$$

Here,  $\mu_o$  and  $\mu_e$  are the refractive indices for the ordinary and the extraordinary rays along  $AP$  and  $AQ$  respectively. In Fig. 10.19,  $CP$  and  $CQ$  are the ordinary and the extraordinary refracted plane wavefronts respectively in the crystal. Therefore, the ordinary and the extraordinary rays travel with different velocities along different direction. Here, the semi-major axis of the ellipsoid is  $\frac{BC}{\mu_e}$  and the semi-minor axis is  $\frac{BC}{\mu_o}$ , where  $\mu_e$  is the principal refractive index for the extraordinary ray and

$$\mu_e < \mu_e < \mu_o$$

Note. The direction  $AE$  of the extraordinary ray is not perpendicular to the tangent  $CQ$ , whereas the direction  $AO$  of the ordinary ray is perpendicular to the tangent  $CP$ .

and as glass windows in trains and aeroplanes. In aeroplanes, one of the polaroids is fixed while the other can be rotated to control the amount of light coming inside.

### 10.30 FRESNEL'S RHOMB

Fresnel constructed a rhomb of glass whose angles are  $54^\circ$  and  $126^\circ$  as shown in Fig. 10.38, based upon the fact that a phase difference of  $\frac{\pi}{4}$  is introduced between the component vibrations (parallel and perpendicular to the plane of incidence) when light is totally internally reflected back at glass-air interface when the angle of incidence is  $54^\circ$ .

A ray of light enters normally at one end of the rhomb and is totally internally reflected at the point  $B$  along  $BC$ . The angle of incidence at  $B$  is  $54^\circ$ , which is more than the critical angle of glass. Let the incident light be plane polarized and let the vibrations make an angle of  $45^\circ$  with the plane of incidence. Its components (i) parallel to the plane of incidence and (ii) perpendicular to the plane of incidence are equal. These components after reflection at the point  $B$  undergo a phase difference of  $\frac{\pi}{4}$  or a path difference of  $\frac{\lambda}{8}$ . A further phase difference of  $\frac{\pi}{4}$  or a path difference of  $\frac{\lambda}{8}$  is introduced between the components when the ray  $BC$  is totally internally reflected back along  $CD$ . Therefore the final emergent ray  $DE$  has two components, vibrating at right angles to each other and they have a path difference of  $\frac{\lambda}{4}$ . Therefore, the emergent light  $DE$  is circularly polarized. Fresnel's rhomb works similar to a quarter wave plate.

If the light entering the Fresnel's rhomb is circularly polarized, a further path difference of  $\frac{\lambda}{4}$  is introduced between the component vibrations.

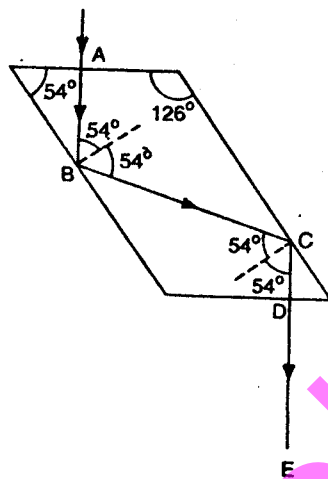

Fig. 10.39

The total path difference between the component vibrations is  $\frac{\lambda}{2}$ . Therefore the emergent light is plane polarised and its vibrations make an angle of  $45^\circ$  with the plane of incidence.

When an elliptically polarized light is passed through a Fresnel's rhomb, a further path difference of  $\frac{\lambda}{4}$  is introduced between the component vibrations (parallel and perpendicular to the plane of incidence). The total path difference between the component vibrations is  $\frac{\lambda}{2}$  and the emergent light is plane polarized.

Thus, Fresnel's rhomb behaves just similar to a quarter wave plate. A quarter wave plate is used only for light of a particular wavelength, whereas a Fresnel's rhomb can be used for light of all wavelengths.

### 10.31 OPTICAL ACTIVITY

When a polarizer and an analyser are crossed, no light emerges out of the analyser [Fig. 10.40 (i)]. When a quartz plate cut with its faces

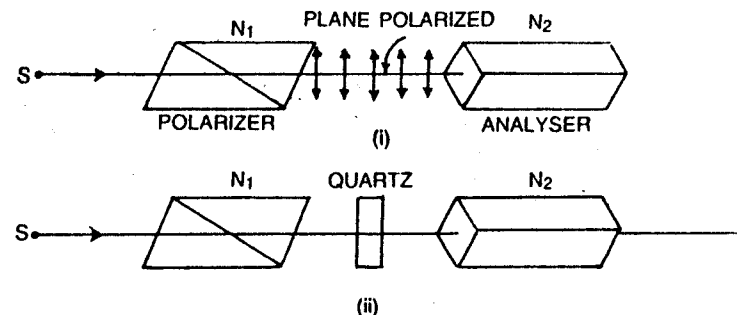

Fig. 10.40

parallel to the optic axis is introduced between  $N_1$  and  $N_2$  such that light falls normally upon the quartz plate, the light emerges out of  $N_2$  [Fig. 10.40 (ii)].

The quartz plate turns the plane of vibration. The plane polarized light enters the quartz plate and its plane of vibration is gradually rotated as shown in Fig. 10.41.

The amount of rotation through which the plane of vibration is turned depends upon the thickness of the quartz plate and the wavelength of light. The action of turning the plane of vibration occurs inside the body of the plate and not on its surface. This phenomenon or the property of rotating the plane of vibration by certain crystals or substances is known as optical

**activity** and the substance is known as an optically active substance. It has been found that calcite does not produce any change in the plane of vibration of the plane polarised light. Therefore, it is not optically active.

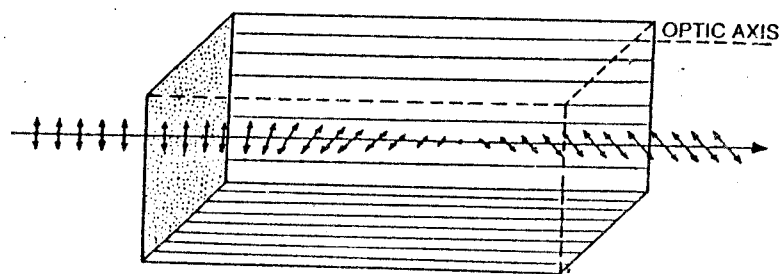

Fig. 10.41

Substances like sugar crystals, sugar solution, turpentine, sodium chlorate and cinnabar are optically active. Some of the substances rotate the plane of vibration to the right and they are called **dextro-rotatory** or **right handed**. Right handed rotation means that when the observer is looking towards light travelling towards him, the plane of vibration is rotated in a clockwise direction. The substances that rotate the plane of vibration to the left (anti-clockwise from the point of view of the observer) are known as **laevo-rotatory** or **left-handed**.

It has been found that some quartz crystals are dextro-rotatory while others are laevorotatory. One is the mirror image of the other in their orientation. The rotation of the plane of vibration in a solution depends upon the concentration of the optically active substance in the solution. This helps in finding the amount of cane sugar present in a sample of sugar solution.

### 10.32 FRESNEL'S EXPLANATION OF ROTATION

A linearly polarized light can be considered as a resultant of two circularly polarized vibrations rotating in opposite directions, with the same angular velocity. Fresnel assumed that a plane polarized light on entering a crystal along the optic axis is resolved into two circularly polarized vibrations rotating in opposite directions with the same angular velocity or frequency.

In a crystal like calcite, the two circularly polarized vibrations travel with the same angular velocity.

In Fig. 10.42,  $OL$  is the circularly polarised vector rotating in the anti-clockwise direction and  $OR$  is the circularly polarized vector rotating in the clockwise direction. The resultant vector of  $OR$  and  $OL$  is  $OA$ . According to Fresnel, when linearly polarised light enters a crystal of calcite along the optic axis, the circularly polarized vibrations, rotating in opposite directions, have the same velocity. The resultant vibration will be along  $AB$ . Thus, crystals like calcite do not rotate the plane of vibration.

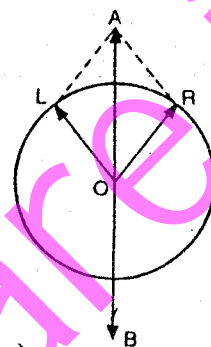

Fig. 10.42

In the case of quartz, the linearly polarized light, on entering the crystal is resolved into two circularly polarized vibrations rotating in opposite directions. In the case of a right-handed optically active crystal, the clockwise rotation travels faster while in a left-handed optically active crystal the anti-clockwise rotation travels faster.

Considering a right-handed quartz crystal (Fig. 10.43) the clockwise component travels a greater angle  $\delta$  than the anticlockwise component when they emerge out of the crystal. The resultant of these two vectors  $OR$  and  $OL$  is along  $OA'$ . Therefore, the resultant vibrations are along  $A'B'$ . Before entering the crystal, the plane of vibration is along  $AB$  and after emerging out of the crystal it is along  $A'B'$ . Therefore, the plane of vibration has rotated through an angle  $\frac{\delta}{2}$ . The angle, through which the plane of vibration is rotated, depends upon the thickness of the crystal.

#### Analytical Treatment for Calcite.

Circularly polarised light is the resultant of two rectangular components having a phase difference of  $\frac{\pi}{2}$ .

For clockwise circular vibrations,

$$x_1 = a \cos \omega t$$

$$x_2 = a \sin \omega t$$

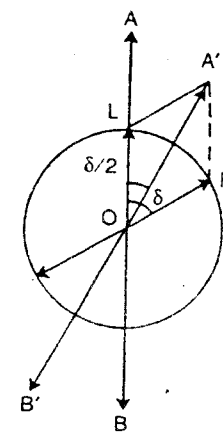

Fig. 10.43

## Polarimeter :

Liquids containing an optically active substance e.g. Sugar solution rotate the plane of the linearly polarized light. The angle through which the plane of polarization is rotated by the optically active substance is determined with the help of a polarimeter.

---

FOR MORE VISIT

FOR MORE VISIT

[www.euelibrary.com](http://www.euelibrary.com)

We are Digital