



WARDROBE ACCESSORIES

A BEAUTIFUL COMBINATION OF DESIGN AND FUNCTION

Your wardrobe should adjust to the way you stock your clothes and arrange your shoes or bags. For the perfect wardrobe organising experience, from planning to use, Häfele brings to you a whole New Range of Wardrobe Accessories which will appeal to your individual taste and use. These accurately tailored products allow for an instant and clear overview of all your treasured belongings; all you need is a quick reach into the different storage boxes and shelves to find what you are looking for right away.

Häfele's New Wardrobe Accessories offer effective utilization of wardrobe space, soft & silent closing and efficient internal cabinet systems. They are available for standard wardrobe widths of 600 and 900 mm letting you create your own personal wardrobe system according to the space available to you.

The new additions consist of Storage Boxes, Baskets, Trouser Pull-outs, Shoe & Storage Racks and other accessories. All the organisers and accessories are designed to provide you maximum versatility and functionality making your life easier.



5 YEARS
Warranty

PRODUCT SPECIFICATIONS

STORAGE BOX

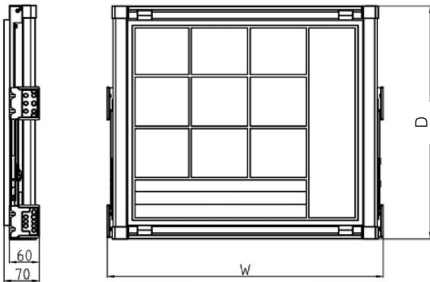

- > Material : Aluminium (Frame), Wood (Base), Felt (Storage Box Interior), Steel (Runners)
- > Finish : Black (Frame), Biscuit Brown (Storage Box Interior)
- > Weight Bearing Capacity : 30 kg
- > Runners : Soft Closing
- > Width Adjustment : 50 mm (25 mm on either side) [Note 1]

- > 1 x Set of Runners
- > 1 x Storage Box
- > 1 x Aluminium Frame
- > Fixing Screws
- > Installation Manual

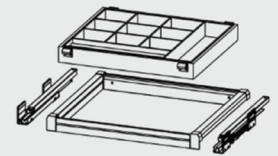

External Cabinet Width	Dimension (WxDxH)	Article No.
600 mm	564 x 475 x 80 mm	807.95.301
900 mm	864 x 475 x 80 mm	807.95.304

LEATHER STORAGE BOX

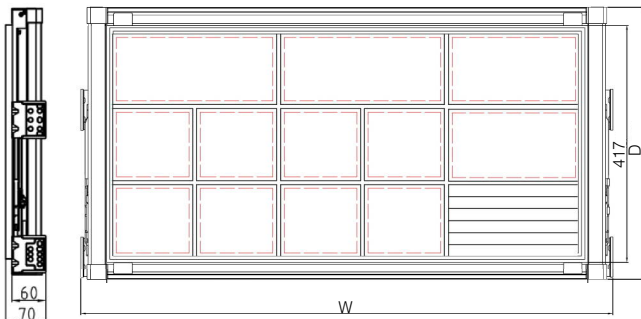

- > Material : Aluminium (Frame), Wood (Base), Leather (Storage Box Interior), Steel (Runners)
- > Finish : Black (Frame), Peanut Brown (Storage Box Interior)
- > Weight Bearing Capacity : 30 kg
- > Runners : Soft Closing
- > Width Adjustment : 50 mm (25 mm on either side) [Note 1]

- > 1 x Set of Runners
- > 1 x Leather Storage Box
- > 1 x Aluminium Frame
- > Fixing Screws
- > Installation Manual

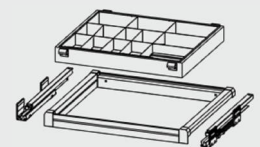

External Cabinet Width	Dimension (WxDxH)	Article No.
600 mm	564 x 475 x 80 mm	807.96.331
900 mm	864 x 475 x 80 mm	807.96.334

Note 1: The runner to runner width of the Aluminium Frame (that comes along with the BOM Kit) is adjustable from 564 / 864 mm (for standard external cabinet width of 600 / 900 mm respectively, considering cabinet side thickness as 18 mm) to 614 / 914 mm (if the width of the cabinet is more than 600 / 900 mm respectively). The total adjustable width is therefore 50 mm (614-564 / 914-864). The frame width can be extended by pulling it from both the sides.

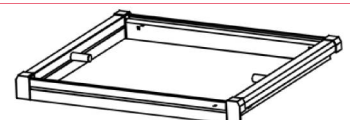

PRODUCT SPECIFICATIONS

SEMI-OPEN STORAGE BOX

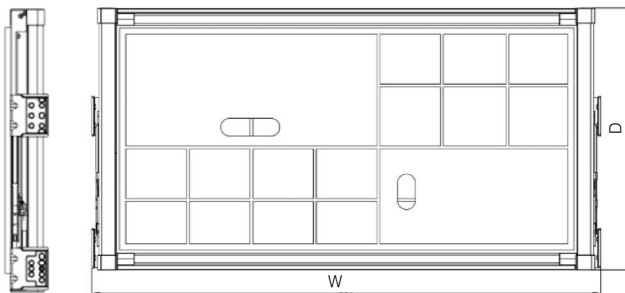

- > Material : Aluminium (Frame), Wood (Storage Box), Steel (Runners)
- > Finish: Black (Frame), Beige (Storage Box Interior)
- > Weight Bearing Capacity: 30 kg
- > Runners : Soft Closing
- > Width Adjustment : 50 mm (25 mm on either side) [Note 1]

External Cabinet Width	Dimension (WxDxH)	Article No.
900 mm	864 x 475 x 80 mm	807.96.344

- > 1 x Set of Runners
- > 1 x Semi-open Storage Box
- > 1 x Aluminium Frame
- > Fixing Screws
- > Installation Manual

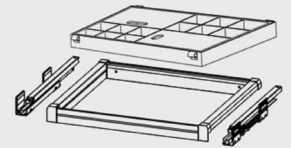

METAL BOX

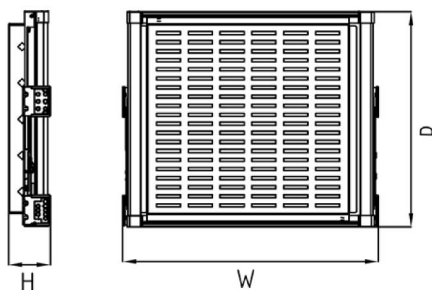

- > Material : Aluminium (Frame), Perforated Steel (Metal Box), Steel (Runners)
- > Finish: Black
- > Weight Bearing Capacity: 30 kg
- > Runners : Soft Closing
- > Width Adjustment : 50 mm (25 mm on either side) [Note 1]

External Cabinet Width	Dimension (WxDxH)	Article No.
600 mm	564 x 475 x 150 mm	807.95.351
900 mm	864 x 475 x 150 mm	807.95.354

- > 1 x Set of Runners
- > 1 x Metal Box
- > 1 x Aluminium Frame
- > Fixing Screws
- > Installation Manual

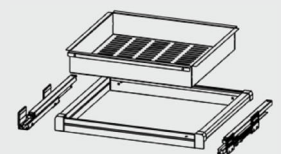

Note 1: The runner to runner width of the Aluminium Frame (that comes along with the BOM Kit) is adjustable from 564 / 864 mm (for standard external cabinet width of 600 / 900 mm respectively, considering cabinet side thickness as 18 mm) to 614 / 914 mm (if the width of the cabinet is more than 600 / 900 mm respectively). The total adjustable width is therefore 50 mm (614-564 / 914-864). The frame width can be extended by pulling it from both the sides.

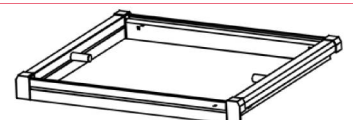

PRODUCT SPECIFICATIONS

PVC RATTAN BASKET

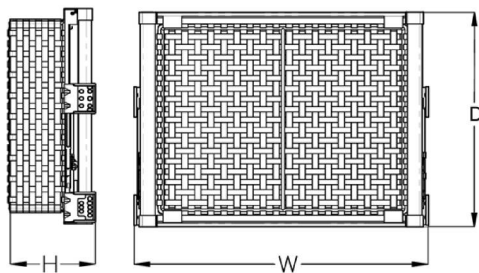

- > Material : Aluminium (Frame), PVC Rattan (Basket), Steel (Runners)
- > Finish : Black (Frame), Wheat Brown (Basket)
- > Weight Bearing Capacity : 30 kg
- > Runners : Soft Closing
- > Width Adjustment : 50 mm (25 mm on either side) [Note 1]

- > 1 x Set of Runners
- > 1 x PVC Rattan Basket
- > 1 x Aluminium Frame
- > Fixing Screws
- > Installation Manual

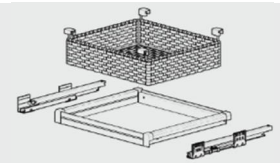

External Cabinet Width	Dimension (WxDxH)	Article No.
600 mm	564 x 475 x 170 mm	807.96.351
900 mm	864 x 475 x 170 mm	807.96.354

TROUSER PULL-OUT

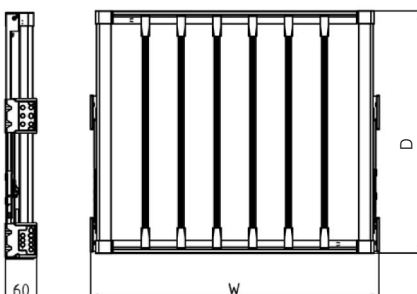

- > Material : Aluminium (Frame), Steel (Runners), Aluminium with Anti-skid Rubber Coating (Braces)
- > Finish : Black
- > Weight Bearing Capacity : 30 kg
- > Runners : Soft Closing
- > Width Adjustment : 50 mm (25 mm on either side) [Note 1]
- > Position of Braces : Adjustable

- > 1 x Set of Runners
- > 6 (807.95.321)/ 9 (807.95.324) x Braces
- > 1 x Aluminium Frame
- > Fixing Screws
- > Installation Manual

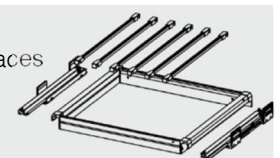

External Cabinet Width	Dimension (WxDxH)	Article No.
600 mm	564 x 475 x 60 mm	807.95.321
900 mm	864 x 475 x 60 mm	807.95.324

Note 1: The runner to runner width of the Aluminium Frame (that comes along with the BOM Kit) is adjustable from 564 / 864 mm (for standard external cabinet width of 600 / 900 mm respectively, considering cabinet side thickness as 18 mm) to 614 / 914 mm (if the width of the cabinet is more than 600 / 900 mm respectively). The total adjustable width is therefore 50 mm (614-564 / 914-864). The frame width can be extended by pulling it from both the sides.

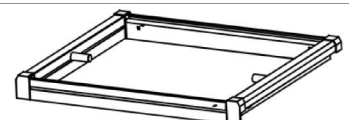

PRODUCT SPECIFICATIONS

MULTI-FUNCTION TROUSER PULLOUT

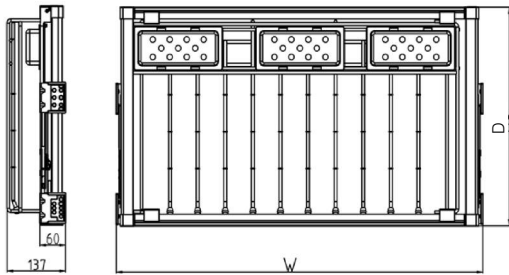

- > Material : Aluminium (Frame), Steel (Runners), Plastic (Trays), Aluminium with Anti-skid Rubber Coating (Braces)
- > Finish : Black
- > Weight Bearing Capacity : 30 kg
- > Runners : Soft Closing
- > Width Adjustment : 50 mm (25 mm on either side) [Note 1]
- > Position of Braces : Fixed

External Cabinet Width	Dimension (WxDxH)	Article No.
600 mm	564 × 475 × 140 mm	807.95.311
900 mm	864 × 475 × 140 mm	807.96.314

- > 1 × Set of Runners
- > 6 (807.95.311)/ 9 (807.96.314) × Braces
- > 2 (807.95.311)/ 3 (807.96.314) × Trays
- > 1 × Aluminium Frame
- > Fixing Screws
- > Installation Manual

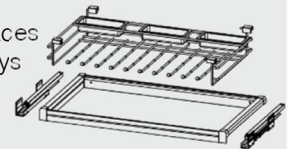

SHOERACK PULL-OUT

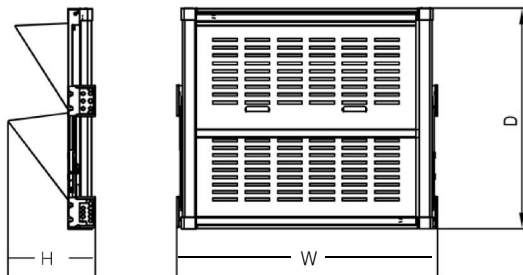

- > Material : Aluminium (Frame), Steel (Runners), Perforated Steel (Shoe Holder)
- > Finish : Black
- > Weight Bearing Capacity : 30 kg
- > Runners : Soft Closing
- > Width Adjustment : 50 mm (25 mm on either side) [Note 1]

External Cabinet Width	Dimension (WxDxH)	Article No.
600 mm	564 × 475 × 180 mm	807.95.361
900 mm	864 × 475 × 180 mm	807.95.364

- > 1 × Set of Runners
- > 1 × Shoe Holder
- > 1 × Aluminium Frame
- > Fixing Screws
- > Installation Manual

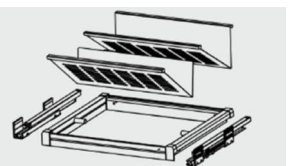

Note 1: The runner to runner width of the Aluminium Frame (that comes along with the BOM Kit) is adjustable from 564 / 864 mm (for standard external cabinet width of 600 / 900 mm respectively, considering cabinet side thickness as 18 mm) to 614 / 914 mm (if the width of the cabinet is more than 600 / 900 mm respectively). The total adjustable width is therefore 50 mm (614-564 / 914-864). The frame width can be extended by pulling it from both the sides.

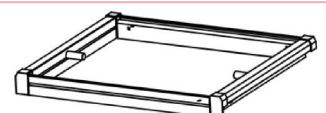

PRODUCT SPECIFICATIONS

ROTATING SHOE RACK

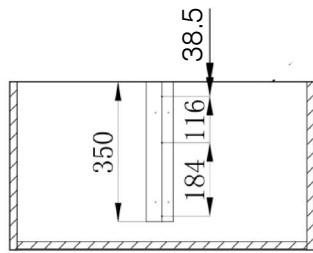
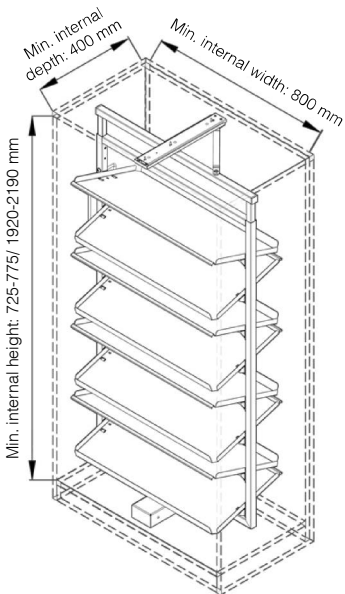

Top of the shoe rack

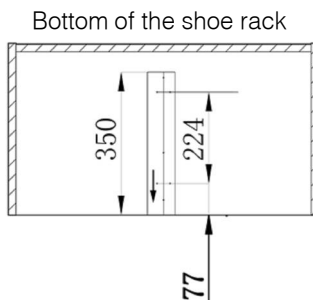

Bottom of the shoe rack

- > Material : Aluminium (Frame), Steel (Runners and Panels)
- > Finish: Black
- > Weight Bearing Capacity: 4 kg per panel
- > Soft Opening and Closing
- > Rotation : 180° on both sides

- > 1 x Rotary Shoe Rack Main Frame
- > 1 x Adjustable Frame
- > 4 (807.95.322) / 12 (807.95.323) x Panels
- > 4 (807.95.322) / 12 (807.95.323) x Bracket Pairs
- > 2 x Handles
- > 1 x Lower and Upper Rail Set
- > Fixing Screws
- > Installation Manual

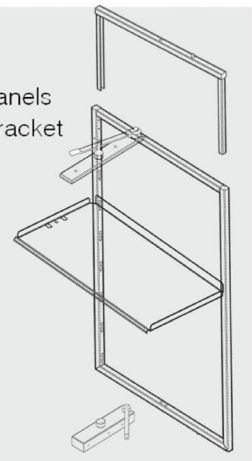

Internal Cabinet Height	Dimension (WxDxH)	Article No.
725-775 mm	700 x 340 x 725-775 mm	807.95.322
1920-2190 mm	700 x 340 x 1920-2190 mm	807.95.323

The images are intended for representation purposes only. Number of shelves may vary with respect to the height of the rotating shoe rack.

PRODUCT SPECIFICATIONS

SIDE STORAGE RACK

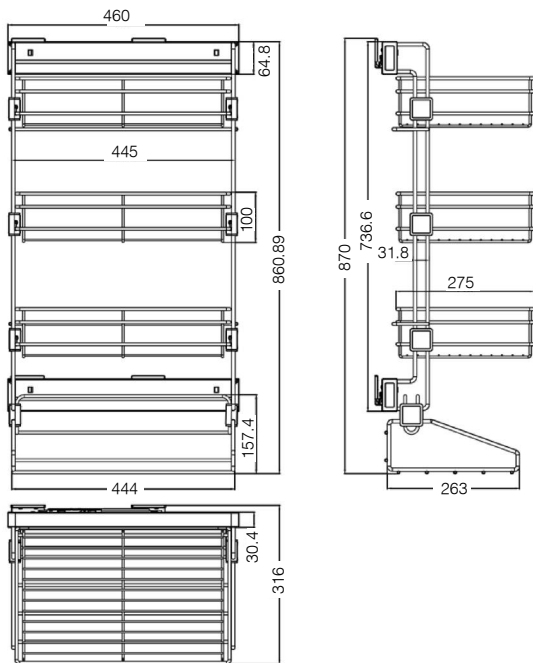

- > Material : Aluminium (Frame), Steel (Runner, Basket, Shelf)
- > Finish: Black
- > Weight Bearing Capacity: 30 kg
- > Runners : Soft Closing
- > Minimum Cabinet Depth : 500 mm

- > 1 x Runner Pair
 - > 3 x Baskets, 1 x Shelf
 - > 1 x Aluminium Frame
 - > Fixing Screws
 - > Installation Manual
-

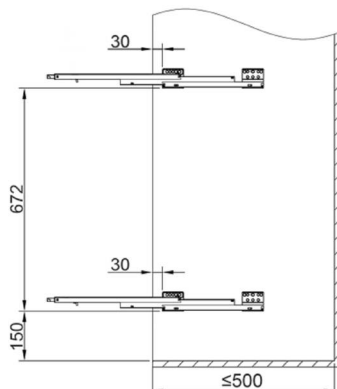

Minimum External Cabinet Dimension (WxD)	Dimension (WxDxH)	Installation	Article No.
400 x 500 mm	316 x 460 x 870 mm	Right	807.95.381
400 x 500 mm	316 x 460 x 870 mm	Left	807.95.380

PRODUCT SPECIFICATIONS

WARDROBE LIFT

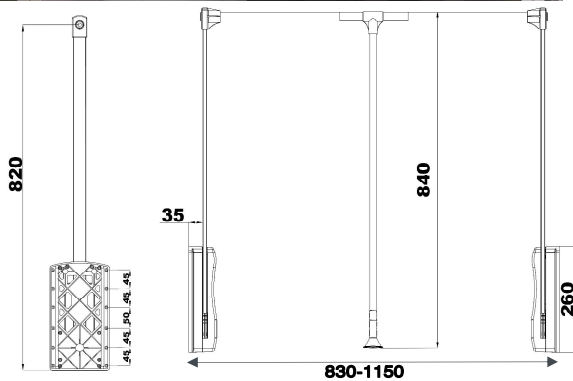

- > Material : Aluminium (Strap Pipe & Arms), Plastic (Side Cover Cap and Pull Handle)
- > Finish : Black
- > Weight Bearing Capacity : 8-10 kg.
- > Mounting : Attached to either sides of the wardrobe with screws
- > Integrated Silent Closing Mechanism
- > The Adjustable Strap Pipe can be extended from 830 mm up to a width of 1150 mm owing to its telescopic structure

- > 2 x Covers
- > 1 x Pull Handle
- > 1 x Adjustable Strap Pipe
- > 2 x Arms
- > 2 x End Connectors
- > Fixing Screws
- > Installation Manual

Minimum Internal Cabinet Width	Dimension (W)	Article No.
830 mm	830-1150 mm	805.11.354

OVAL CLOTH HANGER RAIL

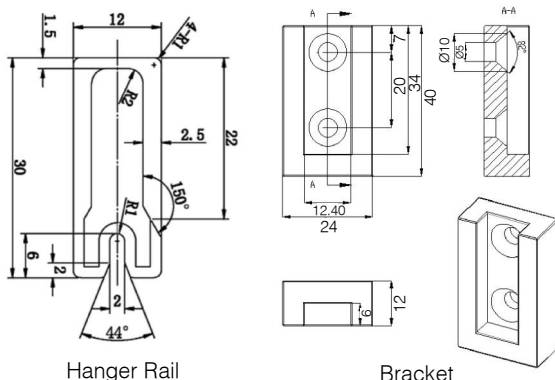

- > Material : Aluminium with Anti-skid Rubber Coating (Rail)
- > Finish : Black
- > Weight Bearing Capacity : 10 Kg

- > 1 x Hanger Rail
- > 2 x Brackets

Description	Dimension (W)	Article No.
Hanger Rail	3000 mm	804.21.303
Side Bracket	--	804.21.390

PRODUCT SPECIFICATIONS

TOP MOUNTED HANGER



- > Material: Steel
- > Finish : Black
- > Weight Bearing Capacity : 10 kg.
- > Integrated Soft Closing Mechanism
- > Hook Points : 9

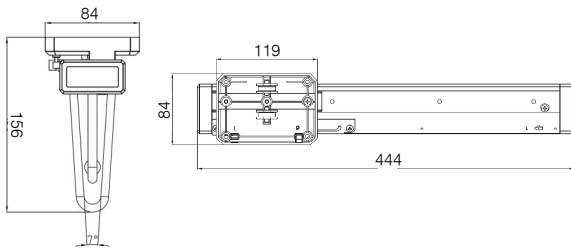

- > 1 × Hanger and Fixing Bracket
- > Fixing Screws
- > Installation Manual

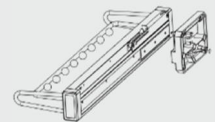

Dimension (W × D × H)	Article No.
84 × 444 × 156 mm	805.00.350

SIDE MOUNTED TIE RACK



- > Material: Steel
- > Finish : Black
- > Weight Bearing Capacity : 10 kg.
- > Integrated Soft Closing Mechanism
- > Hanging points : 9

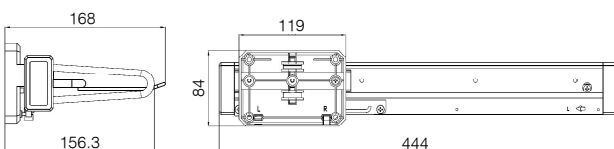

- > 1 × Tie Rack and Bracket
- > Fixing Screws
- > Installation Manual



Dimension (W × D × H)	Article No.
168 × 444 × 85 mm	807.96.310

ORDERING INFORMATION

Article Number	Description
Storage Box	
807.95.301	External Cabinet Width 600 mm
807.95.304	External Cabinet Width 900 mm
Leather Storage Box	
807.96.331	External Cabinet Width 600 mm
807.96.334	External Cabinet Width 900 mm
Semi-open Storage Box	
807.96.344	External Cabinet Width 900 mm
PVC Rattan Basket	
807.96.351	External Cabinet Width 600 mm
807.96.354	External Cabinet Width 900 mm
Metal Box	
807.95.351	External Cabinet Width 600 mm
807.95.354	External Cabinet Width 900 mm
Trouser Pull-out	
807.95.321	External Cabinet Width 600 mm
807.95.324	External Cabinet Width 900 mm
Multi-function Trouser Pull-out	
807.95.311	External Cabinet Width 600 mm
807.95.314	External Cabinet Width 900 mm
Shoe Rack Pull-out	
807.95.361	External Cabinet Width 600 mm
807.95.364	External Cabinet Width 900 mm
Rotating Shoe Rack	
807.95.322	Internal Cabinet Height 725-775 mm
807.95.323	Internal Cabinet Height 1920-2190 mm
Side Storage Rack	
807.95.381	Right Hand Side Opening Width : 400 mm, Depth : 500 mm
807.95.380	Left Hand Side Opening, Width : 400 mm, Depth : 500 mm
Other Accessories	
805.11.354	Wardrobe Lift
804.21.303	Oval Cloth Hanger Rail
804.21.390	Side Bracket for Oval Cloth Hanger Rail
805.00.350	Top Mounted Hanger
807.96.310	Side Mounted Tie Rack

HÄFELE

Häfele India Private Limited

Office No. 3, Building "A", BETA, I Think
Techno Campus, Off J.V.L.R, Opp.
Kanjurmarg East, Mumbai – 400 042.
Phone: 022 6142 6100 | **Fax:** 022 6702 0531.

New Delhi | Kolkata | Cochin | Chennai |
Hyderabad | Bangalore | Mumbai | Pune |
Ahmedabad | Srilanka | Bangladesh | Nepal |
Bhutan | Maldives

Toll Free Customer Care No.: 1800 266 6667
Customer Care WhatsApp No.: +91 9769111122
SMS HAFELE to 56070
info@hafeleindia.com
customercare@hafeleindia.com

