

# SLURRY PUMPS

## ASSEMBLY, OPERATING AND MAINTENANCE INSTRUCTIONS



### PART 2A

## SERIES 'A' SLURRY PUMPS TYPE 'AH' AND 'M'

Information in this publication is subject to change without notice.  
This publication may not be reproduced in whole or in part by any process, electronic or otherwise,  
without the specific written consent of Hebei Tobee Pump Co., Limited

Copyright © Hebei Tobee Pump Co., Limited

## SAFETY INFORMATION

The following safety information relating to pump operation and maintenance should be carefully observed, and correct procedures followed, to avoid injuries to personnel, and damage to equipment. All statutory requirements relating to this equipment must be complied with at all times.

**DO NOT APPLY HEAT TO THE IMPELLER HUB OR INLET EYE** TO ASSIST IMPELLER REMOVAL. APPLICATION OF HEAT MAY RESULT IN SHATTERING OF THE IMPELLER , RESULTING IN INJURY OR EQUIPMENT DAMAGE.

**DO NOT OPERATE THE PUMP FOR AN EXTENDED TIME WITH ZERO OR VERY LOW FLOWRATE.** FAILURE TO OBSERVE THIS WARNING COULD RESULT IN OVERHEATING OF THE PUMP, AND VAPORISATION OF THE PUMPED FLUID, WITH GENERATION OF VERY HIGH PRESSURES. SERIOUS INJURY TO PERSONNEL, OR DAMAGE TO EQUIPMENT MAY RESULT FROM SUCH ACTION.

**CHECK DRIVE MOTOR ROTATION PRIOR TO FITTING OF DRIVE BELTS OR COUPLINGS.** INCORRECT MOTOR ROTATION MAY CAUSE PERSONNEL INJURY OR EQUIPMENT DAMAGE.

**DO NOT FEED VERY HOT OR VERY COLD FLUID INTO A PUMP AT AMBIENT TEMPERATURE.** THERMAL SHOCK MAY RESULT IN FRACTURE OF PUMP WET-END PARTS.

**A WARMAN PUMP MUST BE REGARDED AS BOTH AN ITEM OF ROTATING MACHINERY, AND A PRESSURE VESSEL.** ALL RELEVANT SAFETY PRECAUTIONS AND PROCEDURES FOR SUCH EQUIPMENT SHOULD BE OBSERVED DURING PUMP INSTALLATION, OPERATION AND MAINTENANCE.

**WHERE AUXILIARY EQUIPMENT IS ASSOCIATED WITH A PUMP** (eg MOTORS, DRIVE BELTS, DRIVE COUPLINGS, SPEED REDUCERS, VARIABLE SPEED DRIVES, ETC), ALL RELEVANT INSTRUCTION MANUALS SHOULD BE CONSULTED, AND RECOMMENDED PROCEDURES IMPLEMENTED, DURING INSTALLATION, OPERATION AND MAINTENANCE OF THE PUMP SYSTEM.

**CONTENTS - PART 2A**

	Page
1. INTRODUCTION .....	2 - 1
2. APPLICATION AND FEATURES OF WARMAN SERIES 'A' TYPE 'AH' AND 'M' SLURRY PUMPS .....	2 - 1
3. IDENTIFICATION OF PARTS .....	2 - 1
4. BEARING ASSEMBLY - ASSEMBLY AND MAINTENANCE .....	2 - 2
5. LUBRICATION - BEARING ASSEMBLY AND CENTRIFUGAL SEAL .....	2 - 2
6. PUMP ASSEMBLY INSTRUCTIONS .....	2 - 3
6.1 Frame Assembly .....	2 - 3
6.1.1 Fitting Bearing Assembly to Base .....	2 - 3
6.1.2 Fitting Frame Plate and Cover Plate Bolts .....	2 - 4
6.2 Seal Assembly .....	2 - 6
6.2.1 Gland Seal Assembly .....	2 - 6
6.2.2 Centrifugal Seal Assembly .....	2 - 12
6.2.3 Super Seal Assembly .....	2 - 19
6.2.4 Dyna Seal Assembly .....	2 - 22
6.2.5 Mechanical Seal Assembly .....	2 - 24
6.3 Pump Casing Assembly .....	2 - 25
6.3.1 Elastomer Liners - 2 Piece Type AH Pump Sizes 1.5/1, 2/1.5, 3/2, 4/3 .....	2 - 26
6.3.2 Elastomer Liners - 3 Piece Type AH Pump Sizes 6/4, 8/6, 10/8, 12/10, and 10/8 M .....	2 - 28
6.3.3 Elastomer Liners - 4 Piece Type AH Pump Sizes 14/12, 16/14, 20/18, 10/8 F-R, 12/10 F-R, and 12/10 M .....	2 - 31
6.3.4 Metal Liners - 2 Piece Type AH Pump Sizes 1.5/1, 2/1.5, 3/2, 4/3 .....	2 - 34
6.3.5 Metal Liners - 3 Piece Pump Sizes 6/4 AH and larger .....	2 - 37
6.3.6 Miscellaneous Fittings .....	2 - 41
6.4 Impeller Adjustment .....	2 - 42
7. DISMANTLING PUMP AND REMOVAL OF IMPELLER .....	2 - 44
APPENDIX A - WARMAN BASIC PART NUMBERS .....	2 - 45
APPENDIX B - BOLT TIGHTENING PROCEDURE .....	2 - 47
APPENDIX C - GLAND SEALING WATER FLOWRATE .....	2 - 49

## 1. INTRODUCTION

This publication, **Part 2A**, forms part of a set which together comprise the Assembly, Operating, and Maintenance Instruction Manual for Warman Pumps, Type AH and M. Other publications in the set comprise the following:

**Part 1:** Assembly, Operating and Maintenance Instructions – General Instructions for all Types of Warman Pumps.

**Part:** **3A, 3B, or 3C** – One of these publications, depending on the type of Bearing Assembly fitted, viz. Standard, High Capacity, or Oil Filled.

**Part 4A:** Impeller Release Collar (if applicable)

## 2. APPLICATION AND FEATURES OF SERIES 'A' TYPE 'AH' AND 'M' SLURRY PUMPS

These pumps are of heavy-duty construction, designed for continuous pumping of highly abrasive and corrosive slurries. They feature a wide choice of replaceable abrasion resistant metal or moulded elastomer casing liners and Impellers, which are all interchangeable within a common casing assembly.

The pumps may be fitted with a range of seal types depending on the particular requirements, comprising the Warman centrifugal seal, Warman SuperSeal, a water flushed packed gland seal, and the Warman Dyna Seal. Third party mechanical seals may also be fitted where special sealing requirements favour this type of seal.

If problems are experienced during pump operation, reference should be made to the Fault Detection Chart in Appendix A of Part 1 of the Instruction Manual. If operating problems are not rectified by following instructions in the Chart, assistance should be sought from the nearest C.H. Warman Pump Group office, or its local representative.

Important design features of this range of Warman Slurry Pumps include:

- Cartridge type Bearing Assembly
- Split-tapered Impeller Release Collar on large pumps
- Heavy duty screw thread Impeller attachment
- Through-bolt design throughout
- Easily replaceable Shaft Sleeve
- Replaceable casing liners
- Minimum number of casing bolts

## 3. IDENTIFICATION OF PARTS

Each Warman pump part has a unique name and a three-digit Basic Part Number. Parts with the same name have the same Basic Part Number, regardless of pump size. For example, the Expeller of every Warman pump has the Basic Part Number 028.

Additional letters and numbers are added before and after the Basic Part Number to further define a component part of a particular pump, as described in Part 1 of the Assembly, Operating, and Maintenance Instruction Manual. This expanded marking is identified as the Part Number, and represents a unique identification for each component part. The Part Number is normally cast or otherwise prominently marked on each part.

For example, Part Number D3017 identifies the Cover Plate Liner to fit the casing of the 4/3D-AH Warman Pump.

Refer to the Component Diagram of the appropriate size of Warman Pump for complete identification and description of component parts. Part names and Basic Part Numbers are used in assembly instructions throughout this instruction manual. Warman Basic Part Numbers are listed in Appendix A of this publication.

In all communications with the C.H. Warman Pump Group, or its representatives, and particularly when ordering spare parts, it is recommended that the correct component names and Part Numbers be used at all times to avoid supply of incorrect parts. The pump serial number should also be quoted if any doubt exists as to part identification.

#### **4. BEARING ASSEMBLY – ASSEMBLY AND MAINTENANCE**

The Bearing Assembly is assembled and maintained as described in the separate publication, Part 3A, 3B, or 3C, of the Instruction Manual, depending on the type fitted, as indicated in Section 1.

#### **5. LUBRICATION – BEARING ASSEMBLY AND CENTRIFUGAL SEAL**

It is recommended that grease used for lubricating both the rolling bearings, and the packed gland of the centrifugal seal, should have the following characteristics:

Lithium soap base grease with EP additives and oxidation inhibitors.

N.L.G.I. Consistency No:	2
Drop Point :	> 170° C
Work penetration 25°C A.S.T.M.:	265 – 295

**RECOMMENDED GREASE:**      **SHELL ALVANIA EP GREASE 2, CASTROL EPL2,**  
or equivalent

For detailed description of lubrication requirements for the rolling bearings, refer to the separate publication, Part 3 of the Instruction Manual as listed in Section 1, for the particular Bearing Assembly fitted to the pump.

The static seal chamber of centrifugally sealed pumps should be lubricated sparingly but regularly by means of the grease nipple fitted to the Expeller Ring. Several shots from a grease gun per 12 hours running time, based on mid range pump size, are recommended to form an adequate seal at the packing rings.

## 6. PUMP ASSEMBLY INSTRUCTIONS

Reference to a Component Diagram for the particular pump being assembled will be of assistance in following the instructions outlined in the following sections.

It should be noted that intake and discharge flanges on 10/8F-M, 10/8F-R, 12/10F-M, and 12/10F-R pumps are provided with 12 bolt holes in each flange. This is to provide for both 4 and 8 bolt flanges that are specified in different pump sizes, for which the Cover and Frame Plates are common to both sizes. The Type 'M' pumps, ie 10/8F-M and 12/10F-M, provide for 8 bolts in the intake and discharge flanges, whereas the Type 'R' pumps, ie 10/8F-R, and 12/10F-R, provide for 4 bolts in both flanges, located in the "off-centreline" positions. Type 'M' and 'R' pumps of the same size use common parts for the Cover and Frame Plates.

All parts dismantled during pump overhaul should be inspected to assess suitability for re-use, and identification of new parts should be checked.

Parts suitable for re-use should be cleaned and painted. Matching faces should be free of rust, dirt, and burrs, and have a coating of anti-seize compound applied prior to assembly.

Small fasteners should preferably be replaced, and all threads coated with graphite grease before assembly.

Replacement of all elastomer seals is recommended at major overhauls, as these materials tend to deteriorate with use. Exposure to direct and continuous sunlight will accelerate material degradation.

### 6.1 FRAME ASSEMBLY

#### 6.1.1 Fitting Bearing Assembly to Base

##### - Refer Figs 1 and 13

- (i) Insert ADJUSTING SCREW (001) in BASE (003) from end face. Fix to Base by fitting one nut and fully tighten. Fit two additional nuts separated by two flat washers. These nuts should be loose on Adjusting Screw and spaced well apart.
- (ii) Apply anti-seize compound to semi-circular machined surfaces (Bearing Housing support cradle) in Base.
- (iii) Lower BEARING ASSEMBLY (005) into Base. Approximately match machined surfaces of the Bearing Housing with those in Base. Ensure that the Bearing Housing lug has fitted over the Adjusting Screw mounted in the Base, and that it fits between the nuts and washers.
- (iv) Fit HEX HEAD BOLTS through Base from below. Mount CLAMP WASHER (011) on each bolt (domed side up) and screw on nuts. Fully tighten Bolts on side 'A', i.e. on left hand side of Base as viewed from the Impeller end (refer Figs 1 and 13). Clamp Bolts on the other side (i.e. Side 'B') should not be tightened at this stage. Leave finger tight only, to maintain alignment but allow axial movement of the Bearing Assembly.

- (v) Apply anti-seize compound to SHAFT (073) protruding from LABYRINTH (062) at Impeller end. This will assist fitting and removal of shaft components, and prevent damage to Shaft surfaces by moisture.
- (vi) Fit two pieces of timber, or an appropriate assembly cradle, to underside of Base to prevent the pump from tipping forward during assembly of casing, as shown in Fig 2. Ensure that the Base is at a sufficient height above the floor to enable casing components to be assembled.

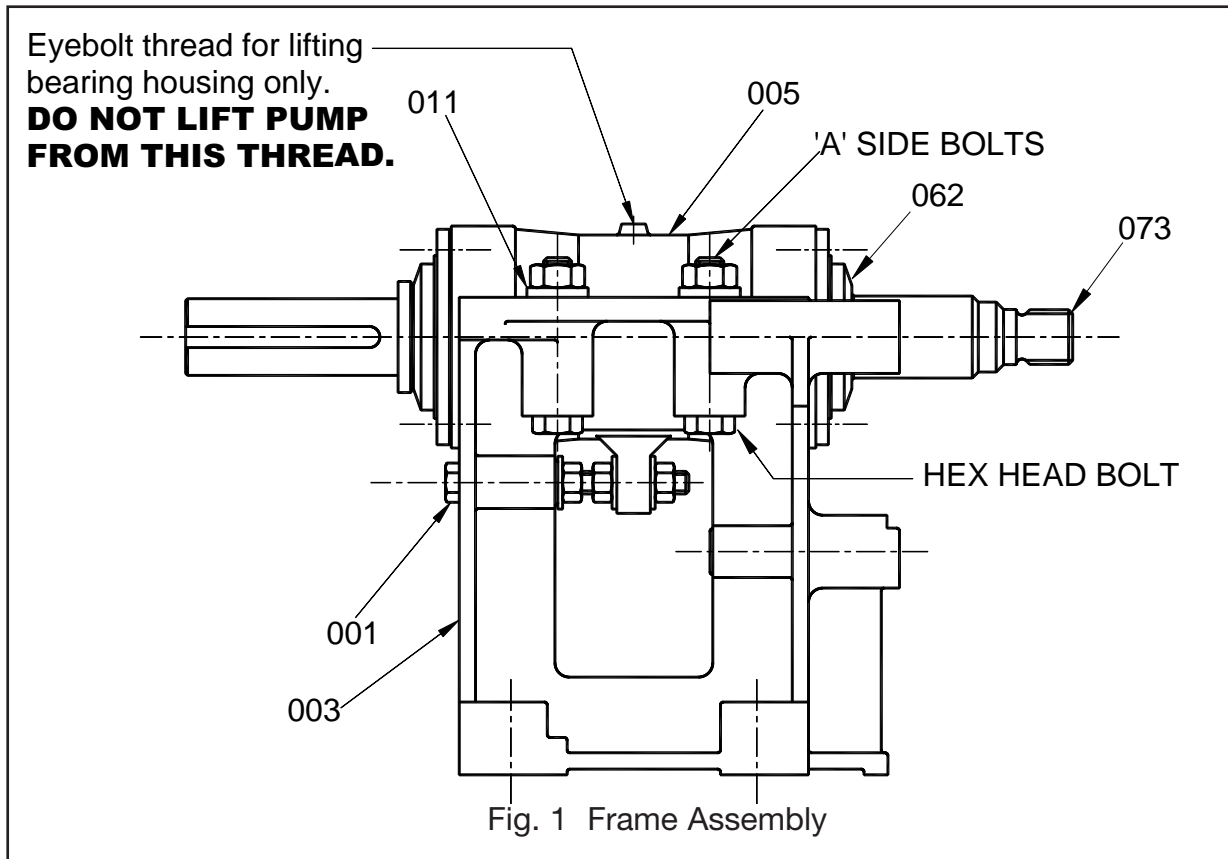

### 6.1.2 Fitting Frame Plate and Cover Plate Bolts

– Refer Fig 2

- (i) Fit FRAME PLATE (032) to Base, ensuring that the Frame Plate locating spigot engages with the corresponding Base recess. Before fitting Frame Plate, apply anti-seize compound to the recess to assist future dismantling. On large pumps, Frame Plates are provided with radially tapped holes for eyebolts to assist lifting.

- (ii) Insert FRAME PLATE STUDS (039) or FRAME PLATE BOLTS (034), depending on pump size. Fit nuts and fully tighten.  
In some pumps the Frame Plate is bolted externally using studs. Some other pumps use bolts which are inserted from within the Frame Plate.  
The Frame Plate can be rotated to provide eight alternative angular discharge positions, except for B Frame pumps, and the 3/2C-AH pump, where only 4 positions are provided.
- (iii) (a) **Rubber Lined Pumps** – Fit COVER PLATE BOLTS (015) through Frame Plate lugs, screw on nuts, and torque all bolts evenly to values shown in Table 1, and in accordance with the tightening sequence indicated in Fig B of Appendix B. If a torque wrench, or equivalent device is not available, bolts should be tightened in accordance with the procedure described in Appendix B.

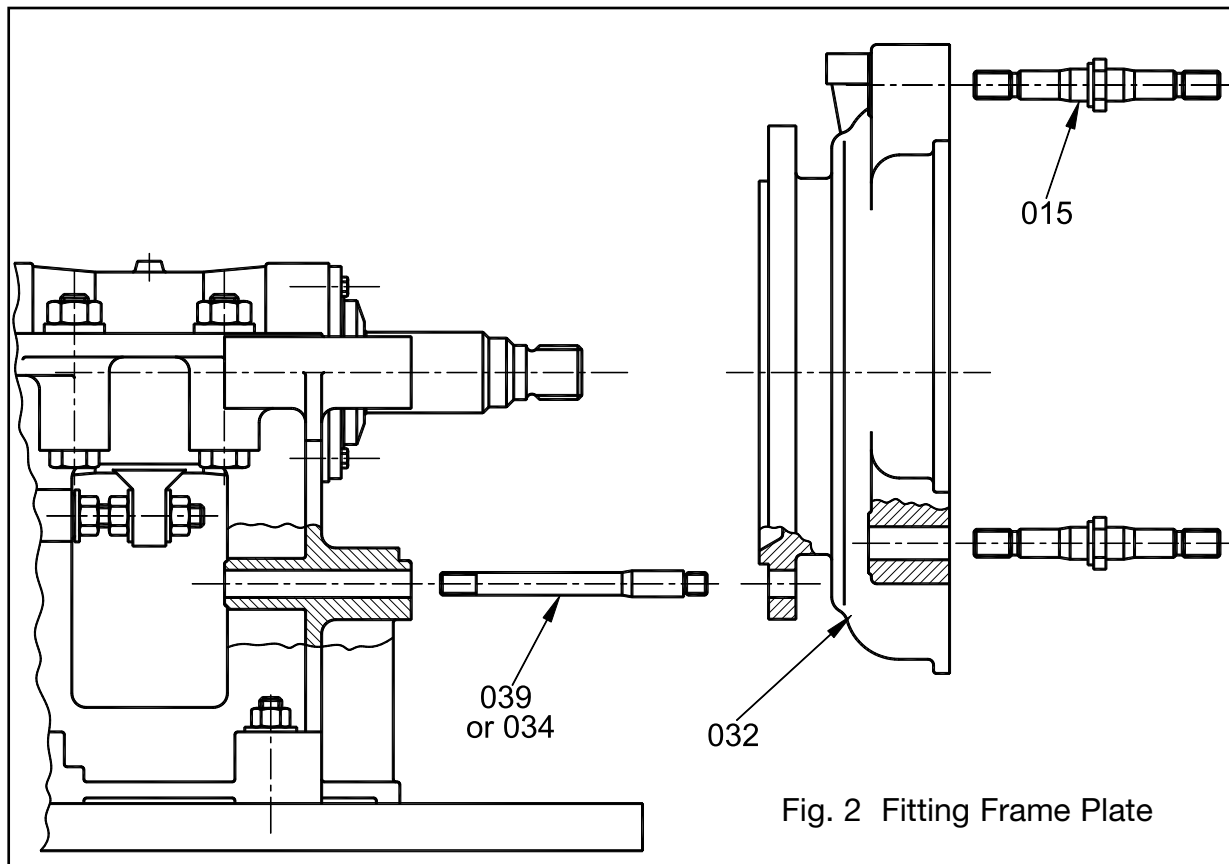

- (b) **Metal Lined Pumps** – Fit through Frame Plate lugs, only those COVER PLATE BOLTS (015) that will **NOT** engage lugs on outside of metal VOLUTE LINER (110) (check Volute Liner for positions of lugs), attach nuts, and torque all bolts evenly, and in accordance with the tightening sequence indicated in Fig B of Appendix B, to values shown in Table 1, or as described in Appendix B, if a torque wrench is not available.



**NOTE:** On some pumps, Cover Plate Bolts are fitted with *KEEPER PLATES (081)* that engage lugs on the outside of the Volute Liners. This applies to the 6/4 AH, 8/6 AH, 10/8 M, and 12/10 M pumps. These Cover Plate Bolts will be fitted later in the assembly.

**TABLE 1**  
**TIGHTENING TORQUE FOR**  
**COVER PLATE BOLTS**

<b>PUMP SIZE</b>	<b>MINIMUM TORQUE (N m)</b>
1.5/1 AH	50
2/1.5 AH	50
3/2 AH	50
4/3 AH	110
6/4 AH	220
8/6 AH	220
10/8 AH	570
12/10 AH	570
14/12 AH	950
16/14 AH	1500
20/18 AH	1500
10/8 M	220
10/8F-R	220
12/10 M	220
12/10F-R	220

## 6.2 SEAL ASSEMBLY

### 6.2.1 GLAND SEAL ASSEMBLY

- **Fitting Stuffing Box, Lantern Restrictor, (or Neck and Lantern Rings), Packing, Gland Assembly, Shaft Sleeve, Shaft Sleeve O- Rings and Shaft Spacer**
- **Refer Figs 3 and 8**

Alternative Stuffing Box assemblies, which may be used depending on the particular pump application, are shown in Fig 4. Gland Sealing Water flowrate may be minimized by using a close-fitting LANTERN RESTRICTOR (118-1), as shown in Fig 4b, or the gland assembly shown in Fig 4c.

It is important that supply pressure and quality of Gland Sealing Water be provided in accordance with recommendations, as described in Section 5.3 of Part 1 of the Assembly, Operating, and Maintenance Instruction Manual.

Minimum recommended flowrate of Gland Sealing Water to be provided for each pump size, and gland assembly as defined in Fig 4, is shown in Appendix C. These flowrates include a nominal provision for Shaft Sleeve wear, which increases clearance at the Lantern Restrictor. Shaft Sleeve wear reduces flushing velocity of the sealing water, and corresponding sealing effectiveness against entry of solid particles to the packing chamber.

Alternative procedures are described below for assembling the seal components, which differ according to pump Frame size. Either method may be used according to individual preference.

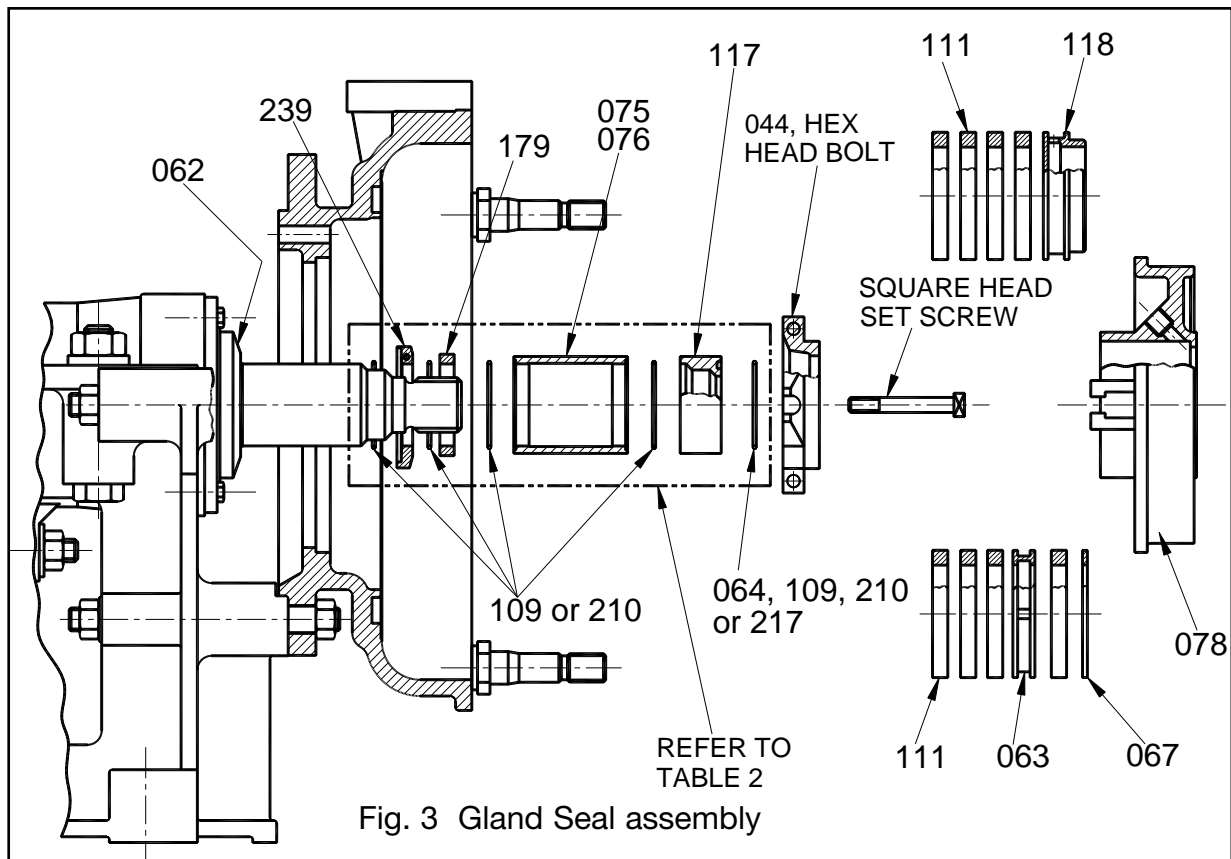

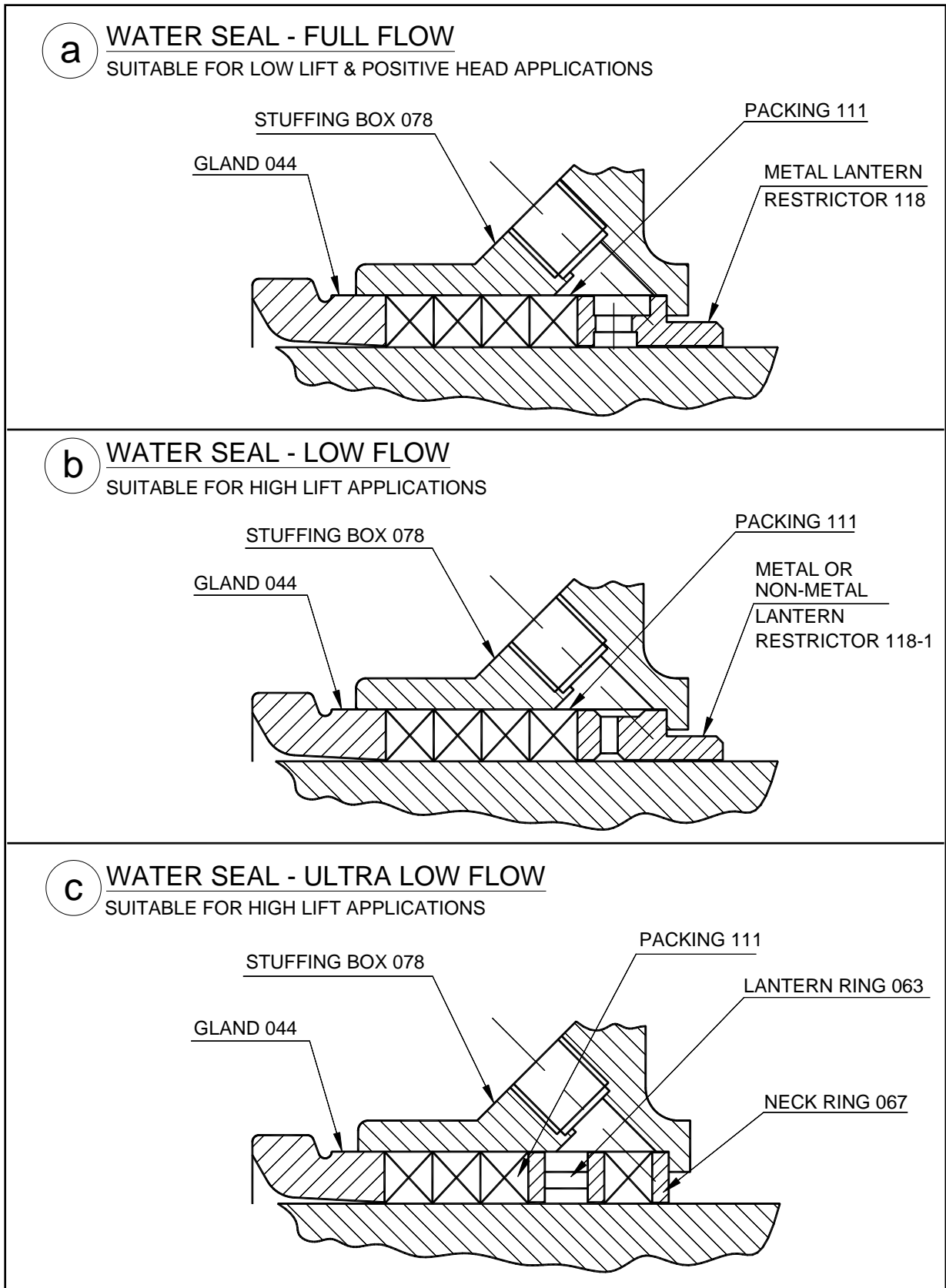

Fig. 4 Alternative Gland arrangements for Stuffing Boxes

**TABLE 2**  
**GLAND SEAL – ORDER OF ASSEMBLY OF COMPONENTS ON SHAFT**

FRAME	PUMP	SHAFT COMPONENTS (in order from Labyrinth to Impeller)
B C	1.5/1B-AH 2/1.5B-AH 3/2C-AH	109 Shaft O-Ring 075 Shaft Sleeve 109 Shaft O-Ring 117 Shaft Spacer 217 Impeller O-Ring
C D E	4/3C-AH 4/3D-AH 10/8E-M & 12/10E-M 6/4E-AH 8/6E-AH	109 Shaft O-Ring 075 Shaft Sleeve 109 Shaft O-Ring 117 Shaft Spacer 064 Impeller O-Ring
D F G	6/4D-AH 8/6F-AH 10/8F-M & 12/10F-M 10/8G-AH & 12/10G-AH 14/12G-AH	109 Shaft O-Ring 075 Shaft Sleeve 109 Shaft O-Ring 117 Shaft Spacer 109 Shaft O-Ring
F	10/8F-AH 12/10F-AH 14/12F-AH	109 Shaft O-Ring 239 Impeller Release Collar 109 Shaft O-Ring 075 Shaft Sleeve FAM117 Shaft Spacer G109 Shaft O-Ring G117 Shaft Spacer G109 Shaft O-Ring
G	16/14G-AH	109 Shaft O-Ring 076 Shaft Sleeve (long) 109 Shaft O-Ring
G	20/18G-AH	109 Shaft O-Ring 239 Impeller Release Collar 109 Shaft O-Ring 076 Shaft Sleeve (long) 109 Shaft O-Ring
H	16/14H-AH	109 Shaft O-Ring 239 Impeller Release Collar 109 Shaft O-Ring 075 Shaft Sleeve 109 Shaft O-Ring 117 Shaft Spacer 064 Impeller O-Ring

Figure 3 shows the relative position of Impeller Release Collar, Shaft Spacer, Shaft Sleeve, O -Rings, etc, on the Shaft. The specific arrangement of these components on the Shaft may vary according to pump size. Table 2 lists the components assembled onto the Shaft, in the order in which they are fitted, commencing at the LABYRINTH (062) at the Impeller-end of the Bearing Assembly. Pumps having similar arrangements of parts are grouped together in the Table.

Generally, pumps having High Capacity Frames (CC, DD, etc) will have the same shaft components as those having Standard Frames ( C, D, E, etc).

### 6.2.1.1 Frames: B, C, D, E, F, CC, DD, EE, FF

Assemble components for Gland Seal Assembly as described below.

- (i) Place STUFFING BOX (078) flat on bench, gland side up.
- (ii) Place LANTERN RESTRICTOR (118) (large diameter up) in gland recess, to rest on retaining lip.  
A NECK RING (067) is fitted in place of the Lantern Restrictor in some applications, as shown in Fig 4c.
- (iii) Stand SHAFT SLEEVE (075, or 076) on end, and slide through Lantern Restrictor.
- (iv) Fit the following items in turn:
  - (a) Fit first PACKING RING (111) of required length to fill the Stuffing Box annulus.
  - (b) Fit remaining Packing Rings (stagger joints) to almost completely fill the Stuffing Box chamber. Flatten each one separately.  
**NOTE** – *When a NECK RING (067) is used, fit LANTERN RING (063) after first Packing Ring, and press down to compress packing. Fit remaining Packing Rings, taking care to stagger joints.*
- (v) Fit GLAND ASSEMBLY (044) over Shaft Sleeve, engage bore of Stuffing Box, and press down to compress Packing Rings. Fit SQUARE HEAD SET SCREWS to recesses in Stuffing Box, engaging holes in Gland Assembly, fit washers and nuts, and tighten just sufficiently to hold Shaft Sleeve (final adjustment will be made when test running pump). A cable tie may be used to secure bolts in position.
- (vi) Determine which components fit between LABYRINTH (062) and SHAFT SLEEVE (075 or 076), from the pump Components Diagram, or from Table 2, for the particular pump being assembled. Fit these components to the Shaft. Refer to Part 4A of the Instruction Manual for details of fitting the IMPELLER RELEASE COLLAR (239), if required.
- (vii) Apply anti-seize compound to Stuffing Box location recess in Frame Plate to assist future removal of Stuffing Box.

Fit the assembled Stuffing Box to Frame Plate, engaging Shaft Sleeve with Shaft, and tapping into position in Frame Plate with a mallet. Locate Stuffing Box with Gland Seal Water connection at the top. LIFTING PLATE (310) should be used in fitting the assembled Stuffing Box to the Frame Plate on pump frames G and larger, as shown in Fig 8.

If the Shaft Sleeve remains forward of its correct position, it should be pushed back until it is firmly in contact with other items assembled on the Shaft. Ensure that any Shaft O-Rings are correctly positioned in grooves.

(viii) Fit remaining O-Rings and Shaft Spacers as indicated in Table 2.

**NOTE:**

(a) *Apply heavy grease to the O-Ring groove to assist in holding the O-Ring which seals against the back face of the Impeller.*

(b) *All O-Rings will be compressed and fully contained within their respective grooves when the Impeller is screwed on to the Shaft.*

(ix) Apply anti-seize compound liberally to Shaft thread.

#### **6.2.1.2 Frames: G, GG, H**

Assemble components for Gland Seal Assembly as described below.

(i) Determine which components fit between the LABYRINTH (062) and IMPELLER, from the pump Components Diagram, or from Table 2, for the particular pump being assembled, and fit these components to the Shaft. Refer to Part 4A of the Instruction Manual for details of fitting the IMPELLER RELEASE COLLAR (239), if required.

**NOTE:**

(a) *Apply heavy grease to the O-Ring groove to assist in holding the O-Ring which seals against the back face of the Impeller.*

(b) *All O-Rings will be compressed and fully contained within their respective grooves when the Impeller is screwed on to the Shaft.*

(ii) Place LANTERN RESTRICTOR (118) (small diameter towards Impeller end) over Shaft Sleeve, and push against Bearing Housing. In some applications, a NECK RING (067), and LANTERN RING (063) are fitted in place of the Lantern Restrictor, as shown in Fig 4c.

(iii) Attach LIFTING PLATE (310) to STUFFING BOX (078), using the 3 jacking screws provided, and ensure that the Gland Seal Water connection in Stuffing Box is in line with the Lifting Beam (see Fig 8).

(iv) Apply anti-seize compound to Stuffing Box location recess in Frame Plate to assist future removal of Stuffing Box. Using a hoist, lift Stuffing Box with Lifting Plate, and insert in Frame Plate, tapping into position with a mallet.

- (v) Assemble all Gland parts in Stuffing Box in the following manner, after all other parts of pump have been assembled.
- (a) Slide LANTERN RESTRICTOR (118) or NECK RING (067) inside Stuffing Box against retaining lip.
  - (b) Fit first PACKING RING (111) of required length to fill the Stuffing Box annulus, and push against the Neck Ring or Lantern Restrictor.
  - (c) Slide LANTERN RING (063) and press to flatten first Packing Ring. When a Lantern Restrictor is used, the Lantern Ring is omitted.
  - (d) Fit remaining Packing Rings (stagger joints) to almost completely fill the Stuffing Box chamber. Flatten each one separately.
  - (e) Dismantle GLAND ASSEMBLY (044) by removing two the clamp bolts. Re-assemble Gland Assembly over Shaft Sleeve, with Gland spigot towards Stuffing Box, re-fit clamp bolts and fully tighten. Fit Gland Assembly into Stuffing Box, and push down to compress Packing Rings. Fit SQUARE HEAD SET SCREWS to recesses in Stuffing Box, engaging holes in Gland Assembly, and tighten sufficiently to remove slack (final adjustment will be made when test running pump). A cable tie may be used to secure bolts in position.
- (vi) Apply anti-seize compound liberally to Shaft thread.

### 6.2.2 CENTRIFUGAL SEAL ASSEMBLY

- **Fitting Expeller Ring, Neck Ring, Lantern Ring, Packing, Gland Assembly, Shaft Sleeve, Shaft Sleeve O-Rings, and Expeller**
- **Refer Figs 5, 6, and 8**

Either metal, or elastomer moulded or lined EXPELLER RINGS (029) may be fitted to the pump. The gland of metal or elastomer lined Expeller Rings is normally fitted with packing, whereas moulded elastomer Expeller Rings should be fitted with lip seals only. Moulded elastomer Expeller Rings are not suitable for use with packing, as lubrication is not provided, and the elastomer inhibits dissipation of heat generated by the packing.

Alternative assembly methods are described below for the centrifugal seal depending upon pump and frame size. The method used in a particular case may be varied according to individual requirements.

Figs 5 and 6 show typical assemblies of shaft components, indicating the relative position of parts on the pump Shaft, which varies according to pump size. Table 2 lists shaft components for a **gland sealed pump** in the order in which are fitted to the Shaft, commencing at the end face of the LABYRINTH (062) on the pump end of the Bearing Assembly. Pumps with similar sets of Shaft components are grouped together in the Table. Generally, in **centrifugally sealed pumps**, the same sets of

component parts apply as for **gland sealed pumps**, except for substituting the EXPELLER (028) for the SHAFT SPACER (117). Exceptions to the general case are listed in Table 3.

High Capacity Frames (CC, DD, etc) generally have the same sets of shaft components as Standard Frames (C, D, etc)

**TABLE 3**

**CENTRIFUGAL SEAL – ORDER OF ASSEMBLY OF COMPONENTS ON SHAFT**  
**(Special cases only – for other pumps refer to Table 2,**  
**and replace 117 Shaft Spacer with 028 Expeller)**

FRAME	PUMP	SHAFT COMPONENTS (in order from Labyrinth to Impeller)
D F	6/4D-AH 8/6F-AH	109 Shaft O-Ring 075 Shaft Sleeve 109 Shaft O-Ring 028 Expeller 064 Impeller O-Ring or 109 Shaft O-Ring
C	4/3C-AH	109 Shaft O-Ring 075 Shaft Sleeve 109 Shaft O-Ring CAM117E Shaft Spacer 109 Shaft Spacer O-Ring D028 Expeller 064 Impeller O-Ring
E	8/6E-AH 10/8E-M 12/10E-M	109 Shaft O-Ring 075 Shaft Sleeve 109 Shaft O-Ring EAM117E Shaft Spacer F109 Shaft Spacer O-Ring F028 Expeller 109 Shaft O-Ring
G	16/14G-AH 20/18G-AH	109 Shaft O-Ring 239 Impeller Release Collar 109 Shaft O-Ring 075 Shaft Sleeve 109 Shaft O-Ring 028 Expeller 109 Shaft O-Ring



### 6.2.2.1 Metal/Polyurethane Lined Expeller Ring (029) - refer Fig 5

The following instructions describe the procedure to pack the gland of the metal or elastomer lined Expeller Ring, which differs according to the pump frame size.

#### (a) Frames: B, C, D, E, F, CC, DD, EE, and FF

- (i) Place EXPELLER RING (029) flat on bench, gland side up.
- (ii) Place NECK RING (067) in gland recess, to rest on retaining lip.
- (iii) Stand SHAFT SLEEVE (075) on end, and slide through Neck Ring.

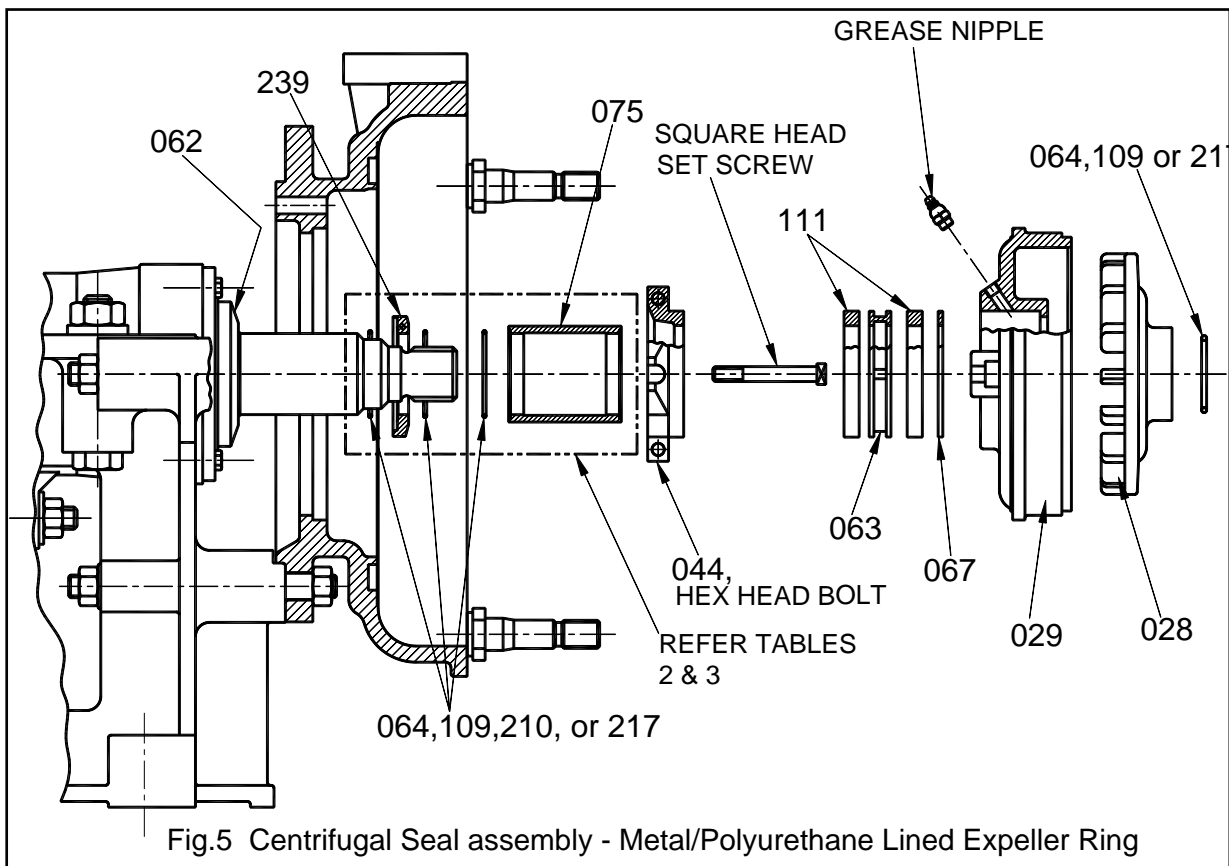

- (iv) Assemble the following items in turn:
  - (1) Fit first PACKING RING (111) of required length to fill the packing annulus.
  - (2) Fit LANTERN RING (063), and press down to flatten first packing ring.
  - (3) Fit remaining Packing Ring.

(v) Fit GLAND ASSEMBLY (044) over Shaft Sleeve, engage bore of Expeller Ring, and press down to compress Packing Rings. Fit SQUARE HEAD SET SCREWS to recesses in Expeller Ring, engaging holes in Gland Assembly, fit washers and nuts, and tighten just sufficiently to hold Shaft Sleeve (final adjustment will be made when test running pump). A cable tie may be used to secure bolts in position.

(vi) Determine which components fit between the LABYRINTH (062) and the SHAFT SLEEVE (075), from the pump Components Diagram, or from Tables 2 and 3 for the particular pump being assembled. Fit these components to the Shaft. Refer to Part 4A of the Instruction Manual for details of fitting the IMPELLER RELEASE COLLAR (239), if required.

(vii) Apply anti-seize compound to Expeller Ring location recess in Frame Plate to assist future removal of Expeller Ring. Fit the assembled Expeller Ring to the Frame Plate, and tap into position with a mallet. Locate Expeller Ring with the grease inlet connection at the top. LIFTING PLATE (310) may be used in fitting the assembled Expeller Ring to the Frame Plate on the larger pump sizes, as shown in Fig 8. If the Shaft Sleeve remains forward of its correct position, it should be pushed back until it is firmly in contact with other items assembled on the Shaft. Ensure that any Shaft O-Rings are correctly positioned in grooves.

(viii) Assemble remaining O-Rings and Shaft Spacers, which fit between SHAFT SLEEVE (075) and EXPELLER (028), as indicated in Tables 2 and 3.

(ix) Fit EXPELLER (028) to Shaft, and move into contact with end of Shaft Sleeve, compressing assembled parts.

(x) Fit O-Ring (109 or 064) to groove in Expeller.

**NOTE:**

(1) *Apply heavy grease to the O-Ring groove to hold the O-Ring which seals against the back face of the Impeller.*

(2) *All O-Rings will be compressed and fully contained within their grooves when the Impeller is screwed to the Shaft.*

(xi) Apply anti-seize compound liberally to Shaft thread.

(xii) Assemble gland lubricating parts, as follows, only when the pump assembly is otherwise complete.

Fit GREASE NIPPLE to Expeller Ring. Apply grease to Nipple with grease gun, to charge Lantern Ring cavity.

If requested, an optional GREASE CUP may be fitted in lieu of the Grease Nipple.

Fit GREASE CUP ADAPTOR (138) and GREASE CUP to Expeller Ring. Fill Grease Cup with recommended grease, and screw down to charge Lantern Ring cavity. Re-fill Grease Cup with grease.

**(b) Frames G, GG, and H**

(i) Determine which components fit between the LABYRINTH (062) and EXPELLER (028), from the pump Components Diagram, or from Tables 2 and 3, for the particular pump being assembled. Fit these components to the Shaft. Refer to Part 4A of the Instruction Manual for details of fitting the IMPELLER RELEASE COLLAR (239), if required.

(ii) Assemble LANTERN RING (063) followed by NECK RING (067) on Shaft Sleeve, and push against Bearing Assembly.

(iii) Fit EXPELLER RING (029) to EXPELLER RING LIFTING BEAM (310), using the three jacking screws, as shown in Fig 8. Ensure that grease inlet on Expeller Ring is in line with the Lifting Beam.

(iv) Apply anti-seize compound to Expeller Ring location recess in Frame Plate to assist future removal of Expeller Ring. Lift Expeller Ring, assembled to Lifting Beam, using a hoist, and fit to Frame Plate, tapping into position with a mallet.

(v) Assemble gland parts in Expeller Ring as described below, when all other pump assembly is complete.

(1) Slide NECK RING (067) along Shaft Sleeve into Expeller Ring gland recess, to rest on retaining lip.

(2) Fit first PACKING RING (111) of required length to fill the packing annulus, and push against Neck Ring..

(3) Slide LANTERN RING (063) on Shaft Sleeve, and press down to flatten first packing ring.

(4) Fit remaining Packing Ring.

(5) Dismantle GLAND ASSEMBLY (044) by removing the two clamp bolts. Re-assemble Gland Assembly over Shaft Sleeve, with Gland spigot towards Expeller Ring, re-fit clamp bolts and fully tighten. Fit Gland Assembly into Expeller Ring packing chamber, and push down to compress Packing Rings. Fit SQUARE HEAD SET SCREWS to recesses in Expeller Ring, engaging holes in Gland Assembly, and tighten sufficiently to remove slack (final adjustment will be made when test running pump). A cable tie may be used to secure bolts in position.

(6) Assemble gland lubricating parts, as follows, only when the pump assembly is otherwise complete.  
Fit GREASE NIPPLE to Expeller Ring. Apply grease to Nipple with grease gun, to charge Lantern Ring cavity.  
If requested, an optional GREASE CUP may be fitted in lieu of the Grease Nipple.

Fit GREASE CUP ADAPTOR (138) and GREASE CUP to Expeller Ring. Fill Grease Cup with recommended grease, and screw down to charge Lantern Ring cavity. Re-fill Grease Cup with grease.

(vi) Assemble SHAFT O-RING (109) between SHAFT SLEEVE (075) and EXPELLER (028), as indicated in Tables 2 and 3.

(vii) Fit EXPELLER (028) to Shaft, and move into contact with end of Shaft Sleeve, compressing assembled parts.

(viii) Fit O-Ring (109 or 064) to groove in Expeller.

**NOTE:**

(1) Apply heavy grease to the Expeller O-Ring groove to hold the O-Ring which seals against the back face of the Impeller.

(2) All O-Rings will be compressed and fully contained within their grooves when the Impeller is screwed to the Shaft.

(ix) Apply anti-seize compound liberally to Shaft thread.

**6.2.2.2 Moulded Elastomer Expeller Ring (029R) - refer Fig 6**

The following instructions describe the procedure to assemble the Centrifugal Seal, incorporating a moulded elastomer Expeller Ring. The procedure varies according to pump size.

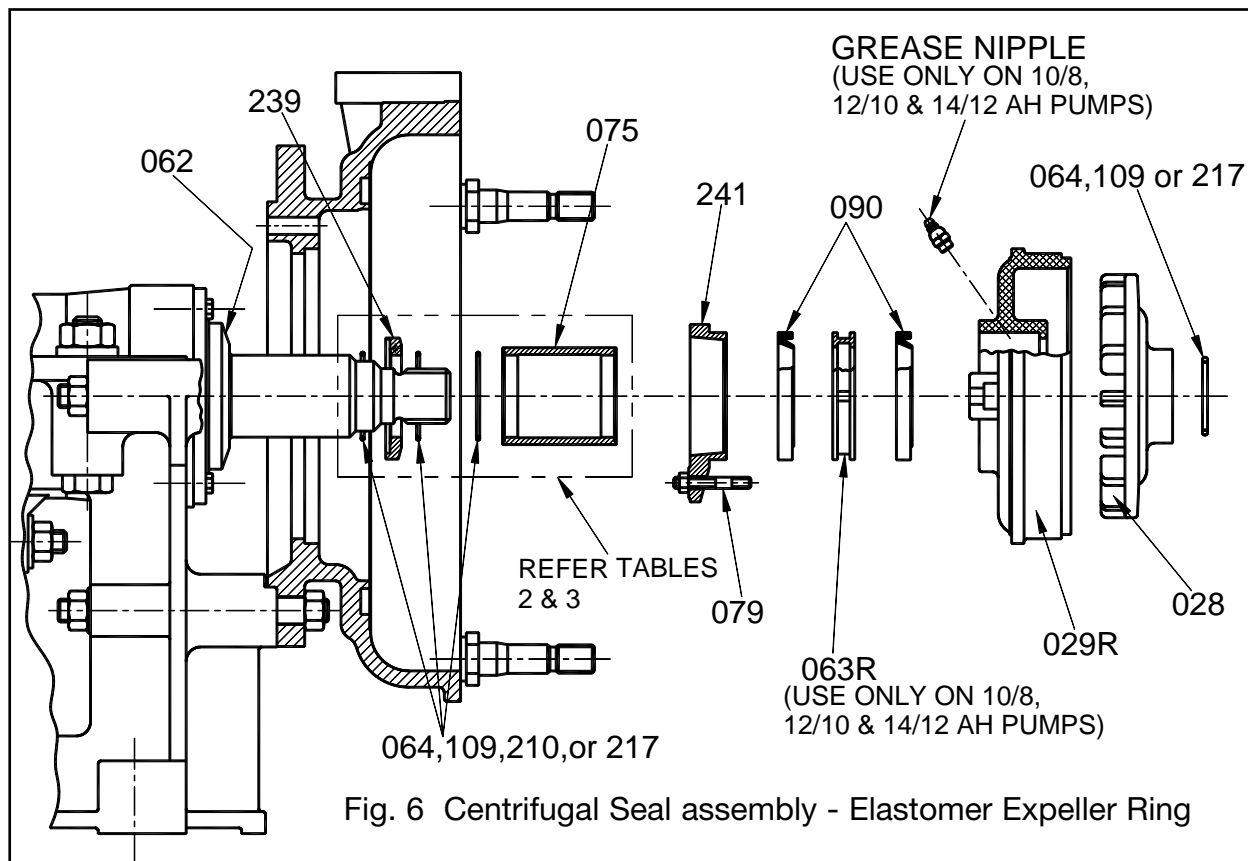

**(a) Pump Sizes 1.5/1 AH, 2/1.5 AH, 3/2 AH, and 4/3 AH**

Expeller Ring Studs or Lipseal Glands are not required with these pump sizes. Only two seals are required, and these are retained by recessed grooves moulded into the Expeller Ring.

- (i) Place EXPELLER RING (029R) flat on bench, 'wet' side up, and fit two LIPSEALS (090) into the bore of the Expeller Ring. Use liquid soap or rubber lubricant to assist fitting if required.

***Continue assembly from item (c) below.***

**(b) Other Pump Sizes**

- (i) Place EXPELLER RING (029R) flat on bench, 'wet' side down.
- (ii) Fit two Expeller Ring STUDS in tapped holes in Expeller Ring, and fully tighten.
- (iii) Fit two LIPSEALS (090) against retaining lip in gland recess, with Seal lips pointing towards Impeller, so that fluid pressure activates the Seals. Apply liquid soap or rubber lubricant to the periphery of the Seals to assist fitting if required. Note that LANTERN RING (063R) is only required in pump sizes 10/8, 12/10, and 14/12 AH.
- (iv) Engage LIP SEAL GLAND (241) in Expeller Ring gland recess, fit nuts to studs, and fully tighten. Gland adjustment is not required.

**(c) All Pump Sizes**

- (i) Determine which components fit between the LABYRINTH (062) and the SHAFT SLEEVE (075), from the pump Components Diagram, or from Tables 2 and 3 for the particular pump being assembled. Fit these components to the Shaft. Refer to Part 4A of the Instruction Manual for details of fitting the IMPELLER RELEASE COLLAR (239), if required.
- (ii) Apply anti-seize compound to Expeller Ring location recess in Frame Plate to assist future removal of Expeller Ring. Fit the assembled Expeller Ring over the Shaft Sleeve, into the Frame Plate, and tap into position with a mallet. Locate the Expeller Ring with Studs on horizontal plane. If the Shaft Sleeve remains forward of its correct position, it should be pushed back until it is firmly in contact with other items assembled on the Shaft. Ensure that any Shaft O-Rings are correctly positioned in grooves.
- (iii) Assemble SHAFT O-RING (109) between SHAFT SLEEVE (075) and EXPELLER (028), as indicated in Tables 2 and 3.
- (iv) Fit EXPELLER (028) to Shaft, and move into contact with end of Shaft Sleeve, compressing assembled parts.

- (v) Fit O-Ring (109 or 064) to groove in Expeller.

**NOTE:**

(1) *Apply heavy grease to the Expeller O-Ring groove to hold the O-Ring, which seals against the back face of the Impeller.*

(2) *All O-Rings will be compressed and fully contained within their grooves when the Impeller is screwed to the Shaft.*

- (vi) Apply anti-seize compound liberally to Shaft thread.

### 6.2.3 SUPERSEAL ASSEMBLY

- **Fitting Expeller Ring, Lantern Ring, Packing, Gland Assembly, Shaft Sleeve, Shaft Sleeve O-Rings, and Expeller**
- **Refer Figs 5 and 8**

Fig 5 is an exploded diagram of the Centrifugal Seal assembly. This also corresponds closely with the SuperSeal assembly, with differences in profiles of the Expeller and Expeller Rings, and the provision of a Neck Ring (067), which is not required with the SuperSeal.

Fig 5 shows a typical assembly of shaft components, indicating the relative position of parts on the pump Shaft, which varies according to pump size. Table 2 lists shaft components for a **gland sealed pump** in the order in which are fitted to the Shaft, commencing at the end face of the LABYRINTH (062) on the pump end of the Bearing Assembly. Pumps with similar sets of Shaft components are grouped together in the Table. Generally, in **SuperSealed pumps**, the same sets of component parts apply as for **gland sealed pumps**, except for substituting the EXPELLER (028) for the SHAFT SPACER (117). Exceptions to the general case are listed in Table 3.

High Capacity Frames (CC, DD, etc) generally have the same sets of shaft components as Standard Frames (C, D, etc)

Alternative assembly methods are described below for the SuperSeal depending upon pump and frame size. The method used in a particular case may be varied according to individual requirements.

#### 6.2.3.1 Metal/Polyurethane Lined Expeller Ring (029) - refer Fig 5

The following instructions describe the procedure to pack the gland of the metal Expeller Ring, which differs according to the pump frame size.

**(a) Frames: B, C, D, E, F, CC, DD, EE, and FF**

- (i) Place EXPELLER RING (029) flat on bench, gland side up.
- (ii) Stand SHAFT SLEEVE (075) on end, and slide through bore of Expeller Ring. Note that a separate NECK RING (067), as used in the Centrifugal Seal Assembly and indicated in Fig 5, is not required in the SuperSeal Assembly.

- (iii) Assemble the following items in turn:
- (1) Fit first PACKING RING (111) of required length to fill the packing annulus, and push against shoulder of Expeller Ring.
  - (2) Fit LANTERN RING (063), and press down to flatten first packing ring.
  - (3) Fit remaining Packing Ring.
- (iv) Fit GLAND ASSEMBLY (044) over Shaft Sleeve, engage bore of Expeller Ring, and press down to compress Packing Rings. Fit SQUARE HEAD SET SCREWS to recesses in Expeller Ring, engaging holes in Gland Assembly, fit washers and nuts, and tighten just sufficiently to hold Shaft Sleeve (final adjustment will be made when test running pump). A cable tie may be used to secure bolts in position.
- (v) Determine which components fit between the LABYRINTH (062) and the SHAFT SLEEVE (075), from the pump Components Diagram, or from Tables 2 and 3 for the particular pump being assembled. Fit these components to the Shaft. Refer to Part 4A of the Instruction Manual for details of fitting the IMPELLER RELEASE COLLAR (239), if required.
- (vi) Apply anti-seize compound to Expeller Ring location recess in Frame Plate to assist future removal of Expeller Ring. Fit the assembled Expeller Ring to the Frame Plate, and tap into position with a mallet. Locate Expeller Ring with the grease inlet connection at the top. LIFTING PLATE (310) may be used in fitting the assembled Expeller Ring to the Frame Plate on the larger pump sizes, as shown in Fig 8. If the Shaft Sleeve remains forward of its correct position, it should be pushed back until it is firmly in contact with other items assembled on the Shaft. Ensure that any Shaft O-Rings are correctly positioned in grooves.
- (vii) Assemble remaining O-Rings and Shaft Spacers, which fit between SHAFT SLEEVE (075) and EXPELLER (028), as indicated in Tables 2 and 3.
- (viii) Fit EXPELLER (028) to Shaft, and move into contact with end of Shaft Sleeve, compressing assembled parts.
- (ix) Fit O-Ring (109 or 064) to groove in Expeller.
- NOTE:**
- (1) *Apply heavy grease to the O-Ring groove to hold the O-Ring which seals against the back face of the Impeller.*
  - (2) *All O-Rings will be compressed and fully contained within their grooves when the Impeller is screwed to the Shaft.*
- (x) Apply anti-seize compound liberally to Shaft thread.

- (xi) Assemble gland lubricating parts, as follows, only when the pump assembly is otherwise complete.  
Fit GREASE NIPPLE to Expeller Ring. Apply grease to Nipple with grease gun, to charge Lantern Ring cavity.  
If requested, an optional GREASE CUP may be fitted in lieu of the Grease Nipple.  
Fit GREASE CUP ADAPTOR (138) and GREASE CUP to Expeller Ring. Fill Grease Cup with recommended grease, and screw down to charge Lantern Ring cavity. Re-fill Grease Cup with grease.

**(b) Frames G, GG, and H**

- (i) Determine which components fit between the LABYRINTH (062) and EXPELLER (028), from the pump Components Diagram, or from Tables 2 and 3, for the particular pump being assembled. Fit these components to the Shaft. Refer to Part 4A of the Instruction Manual for details of fitting the IMPELLER RELEASE COLLAR (239), if required.
- (ii) Assemble LANTERN RING (063) on Shaft Sleeve, and push against Bearing Assembly. Note that a separate NECK RING (067), as used in the Centrifugal Seal Assembly and indicated in Fig 5, is not required in the SuperSeal Assembly.
- (iii) Fit EXPELLER RING (029) to EXPELLER RING LIFTING BEAM (310), using the three jacking screws, as shown in Fig 8. Ensure that grease inlet on Expeller Ring is in line with the Lifting Beam.
- (iv) Apply anti-seize compound to Expeller Ring location recess in Frame Plate to assist future removal of Expeller Ring. Lift Expeller Ring, assembled to Lifting Beam, using a hoist, and fit to Frame Plate, tapping into position with a mallet.
- (v) Assemble gland parts in Expeller Ring as described below, when all other pump assembly is complete.
- (1) Fit first PACKING RING (111) of required length to fill the packing annulus, and push against shoulder of Expeller Ring.
  - (2) Slide LANTERN RING (063) on Shaft Sleeve, and press down to flatten first packing ring.
  - (3) Fit remaining Packing Ring.
  - (4) Dismantle GLAND ASSEMBLY (044) by removing the two clamp bolts. Re-assemble Gland Assembly over Shaft Sleeve, with Gland spigot towards Expeller Ring, re-fit clamp bolts and fully tighten. Fit Gland Assembly into Expeller Ring packing chamber, and push down to compress Packing Rings. Fit SQUARE HEAD SET SCREWS to



recesses in Expeller Ring, engaging holes in Gland Assembly, and tighten sufficiently to remove slack (final adjustment will be made when test running pump). A cable tie may be used to secure bolts in position.

(5) Assemble gland lubricating parts, as follows, only when the pump assembly is otherwise complete.

Fit GREASE NIPPLE to Expeller Ring. Apply grease to Nipple with grease gun, to charge Lantern Ring cavity.

If requested, an optional GREASE CUP may be fitted in lieu of the Grease Nipple.

Fit GREASE CUP ADAPTOR (138) and GREASE CUP to Expeller Ring.

Fill Grease Cup with recommended grease, and screw down to charge Lantern Ring cavity. Re-fill Grease Cup with grease.

(vi) Assemble SHAFT O-RING (109) between SHAFT SLEEVE (075) and EXPELLER (028), as indicated in Tables 2 and 3.

(vii) Fit EXPELLER (028) to Shaft, and move into contact with end of Shaft Sleeve, compressing assembled parts.

(viii) Fit O-Ring (109 or 064) to groove in Expeller.

**NOTE:**

(1) *Apply heavy grease to the Expeller O-Ring groove to hold the O-Ring which seals against the back face of the Impeller.*

(2) *All O-Rings will be compressed and fully contained within their grooves when the Impeller is screwed to the Shaft.*

(ix) Apply anti-seize compound liberally to Shaft thread.

#### 6.2.4 DYNA SEAL ASSEMBLY

- **Fitting Expeller Ring, Shaft Sleeve, Shaft Sleeve O-Rings, Dyna Seal and Expeller**
- **Refer Figs 7 and 8**

Fig 7 shows a typical assembly of shaft components, indicating the relative position of parts on the pump Shaft, which varies according to pump size. Table 2 lists shaft components for a **gland sealed pump** which are fitted to the Shaft in order of assembly, commencing at the end face of the LABYRINTH (062) on the pump end of the Bearing Assembly. Pumps with similar sets of Shaft components are grouped together in the Table. Generally, in **Dyna Sealed pumps**, the same sets of component parts apply as for **gland sealed pumps**, except for substituting the EXPELLER (028) for the SHAFT SPACER (117). Exceptions to the general case are listed in Table 3.

High Capacity Frames (CC, DD, etc) generally have the same sets of shaft components as Standard Frames (C, D, etc).

The following instructions describe the procedure to assemble the Dyna Seal to all applicable pump frame sizes, viz. B, C, D, E, F, G, CC, DD, EE, and FF, GG.

- (i) Determine which components fit between the LABYRINTH (062) and the EXPELLER (028), from the pump Components Diagram, or from Tables 2 and 3 for the particular pump being assembled. Fit these components to the Shaft. Refer to Part 4A of the Instruction Manual for details of fitting the IMPELLER RELEASE COLLAR (239), if required.

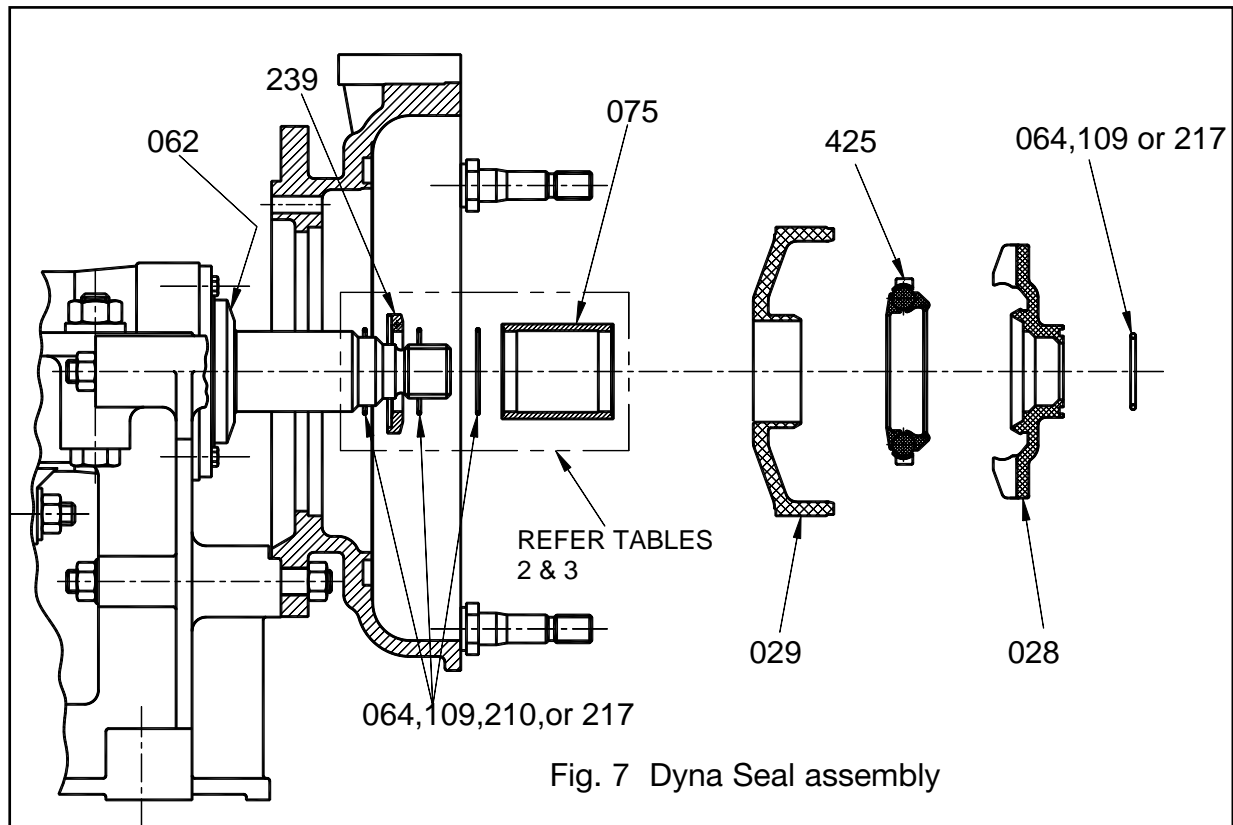

- (ii) Apply anti-seize compound to Expeller Ring location recess in Frame Plate to assist future removal of Expeller Ring. Fit EXPPELLER RING (029) to the Frame Plate, and tap into position with a mallet. LIFTING PLATE (310) may be used in fitting the assembled Expeller Ring to the Frame Plate on the larger pump sizes, as shown in Fig 8. If the Shaft Sleeve remains forward of its correct position, it should be pushed back until it is firmly in contact with other items assembled on the Shaft. Ensure that all Shaft O-Rings are correctly positioned in grooves.

- (iii) Place EXPPELLER (028) flat on bench, with vanes up. Place DYNASEAL (425) loosely in centre of Expeller, with part number markings up. Apply liquid soap or rubber lubricant to lower sealing land surface of Dyna Seal. Adjust angular position of Dyna Seal so that drive lugs projecting from periphery of Seal fit between Expeller vanes. Apply downward pressure on Dyna Seal to expand lower sealing land over matching conical surface of Expeller, and engage sealing land in locating recess in Expeller. If necessary apply load unevenly, at one point on Seal periphery, to locally engage sealing land in recess, and progress around seal to complete engagement.

- (iv) Ensure that the Shaft Sleeve O-Ring at the end of the Shaft Sleeve is positioned in its locating groove.
- (v) Apply liquid soap or rubber lubricant to inner conical sleeve surface of Expeller Ring. Place EXPELLER (028) on Shaft, and carefully apply axial force to back face of Expeller to expand Dyna Seal lip over Expeller Ring sleeve as the Expeller moves along the Shaft into contact with the end of the Shaft Sleeve.

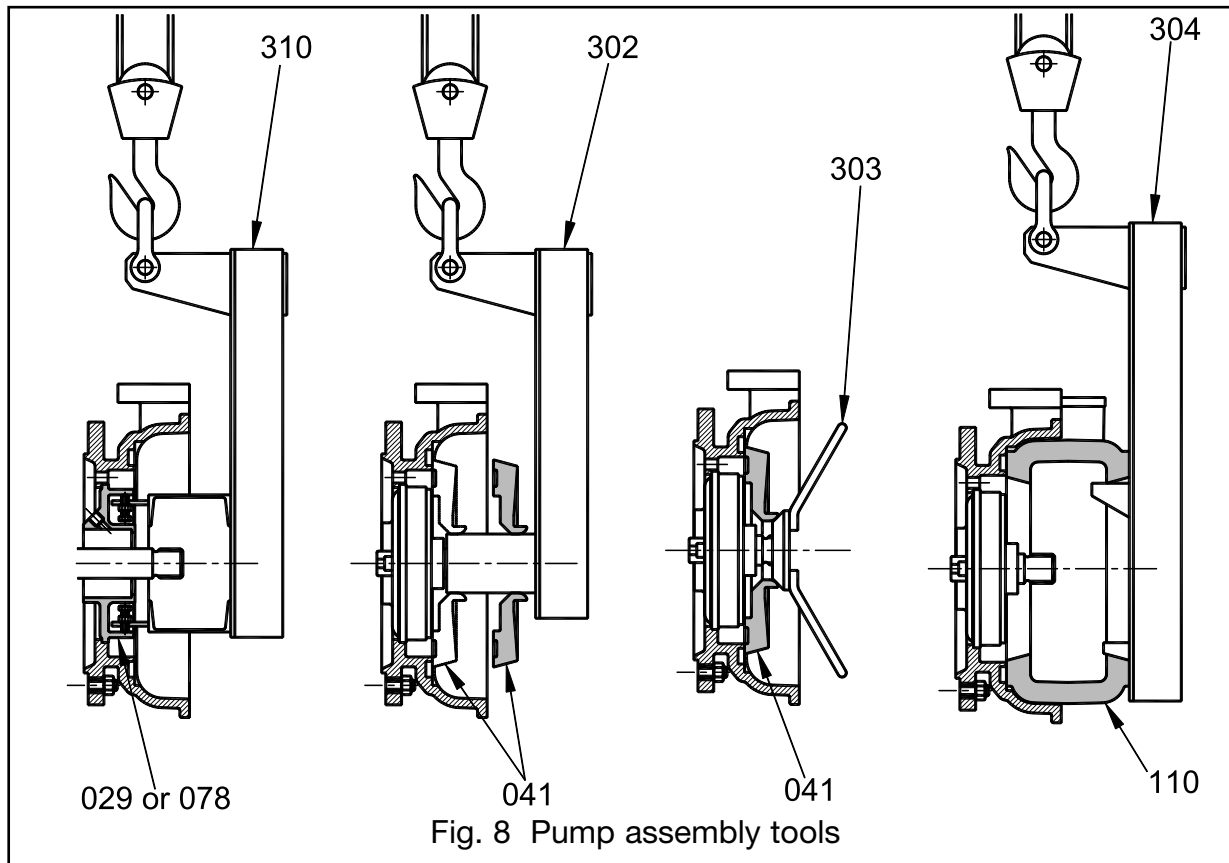

- (vi) Fit O-Ring (109 or 064) to groove in exposed face of Expeller.

**NOTE:**

- (1) Apply heavy grease to the O-Ring groove to hold the O-Ring which seals against the back face of the Impeller.
- (2) All O-Rings will be compressed and fully contained within their grooves when the Impeller is screwed to the Shaft.

- (vii) Apply anti-seize compound liberally to Shaft thread.

**6.2.5 MECHANICAL SEAL ASSEMBLY**

Adaptor kits are available for fitting a number of third party mechanical seals to Warman Pumps. When fitting these seals, reference should be made to supplementary instructions for the particular seal being installed. Further details of third party Mechanical Seals, for which adaptor kits are available, may be obtained from the C.H. Warman Pump Group.

**6.3 PUMP CASING ASSEMBLY**

Table 4 lists the type of pump casing liner configurations for the full range of pump sizes, for both Metal and Elastomer liners, and indicates the relevant section reference for assembly instructions. Liner fit-up is independent of FRAME size. Metal and Elastomer liners may be fitted interchangeably, and a mix of Metal and Elastomer liners is also possible. In these cases reference should be made to the relevant sections indicated in Table 4 for the particular liner combinations used.

**TABLE 4  
PUMP CASING ASSEMBLY**

PUMP	ELASTOMER LINERS			METAL LINERS	
	TWO PIECE Sect 6.3.1	THREE PIECE Sect 6.3.2	FOUR PIECE Sect 6.3.3	TWO PIECE Sect 6.3.4	THREE PIECE Sect 6.3.5
1.5/1 AH	•			•	
2/1.5 AH	•			•	
3/2 AH	•			•	
4/3 AH	•			•	
6/4 AH		•			•
8/6 AH		•			•
10/8 AH		•			•
12/10 AH		•			•
14/12 AH			•		•
16/14 AH			•		•
20/18 AH			•		•
10/8 M		•			•
10/8 F-R			•		
12/10 M			•		•
12/10 F-R			•		

NOTE: • indicates Standard Liner fit-up, and is independent of Frame size.

### 6.3.1 ELASTOMER LINERS - TWO PIECE

- Fitting Frame Plate Liner, Impeller, Cover Plate Liner, and Cover Plate
- Refer Fig 9

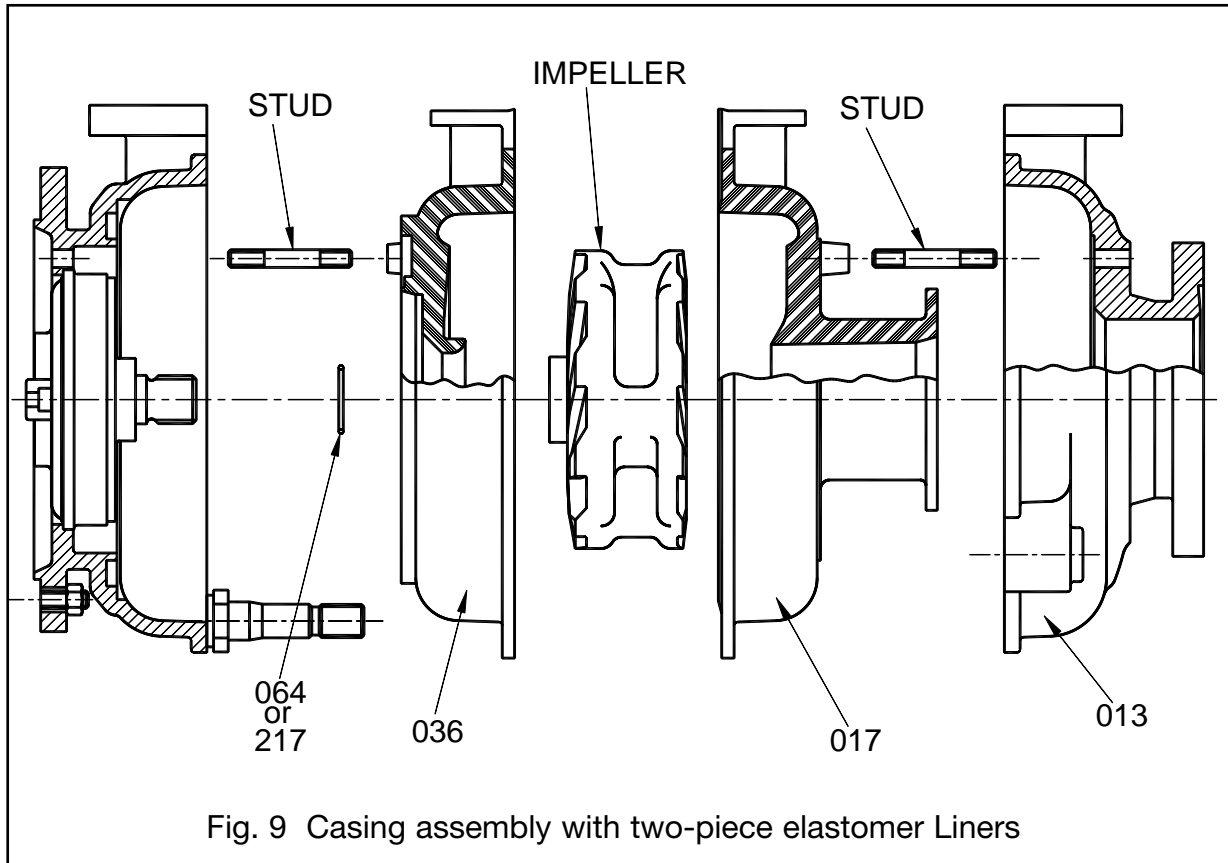

Fig. 9 Casing assembly with two-piece elastomer Liners

Pumps at the small end of the range have only two elastomer casing liners, comprising the Cover Plate Liner and Frame Plate Liner. In larger pumps, one or both of these liners are divided into two separate liners. Pumps having Two-Piece elastomer liners comprise **sizes 1.5/1 AH, 2/1.5 AH, 3/2 AH, and 4/3 AH**. The pump casing assembly, with Two-Piece elastomer liners, is described below.

- (i) Fit FRAME PLATE LINER (036) as described below:
  - (a) Fit and tighten STUDS to tapped bosses in Frame Plate Liner. If Studs are not square to the face of the Liner, screw a nut on the thread, and adjust by tapping lightly with a hammer.
  - (b) Lift Liner in position, lining up Studs with corresponding holes, and push into Frame Plate. Fit Nuts to Studs, and tighten finger tight plus half a turn (max).

- (ii) Select the appropriate IMPELLER required for the pump assembly, and fit as follows:
  - (a) Place Impeller (thread up) on a flat surface, apply anti-seize compound to thread, and screw Impeller to Shaft.
  - (b) Fit SHAFT KEY (070) in Shaft keyway, and bolt SHAFT WRENCH (306) to Shaft, over key. While restraining Shaft with Wrench, and turning Impeller with a bar between vanes, firmly screw Impeller to Shaft, but do not overtighten. Ensure that the various O-Rings on the Shaft are not damaged, and are covered by adjacent parts
- (iii) Fit COVER PLATE LINER (017), and COVER PLATE (013), as described below.
  - (a) Fit and tighten STUDS to tapped bosses in Cover Plate Liners (3/2 AH and 4/3 AH pumps only). If Studs are not square to the face of the Liner, screw a nut on the thread, and adjust by tapping lightly with a hammer.
  - (b) Place Cover Plate Liner on a flat surface, intake flange up. Liberally apply liquid soap or rubber lubricant to the intake flange and intake surface of the Cover Plate.
  - (c) Place Cover Plate over Cover Plate Liner, lining up Studs with corresponding holes (3/2 AH, 4/3 AH pumps only)), and push Cover Plate down until it engages firmly with the Liner. Place a small tyre lever, or similar, between intake surface and Liner, and lever flange out of Cover Plate intake. Fit Nuts to Studs, and tighten finger tight plus half a turn (max).
  - (d) Lift Cover Plate, with Liner fitted, and align holes with COVER PLATE BOLTS (015) assembled in the Frame Plate. Fit Nuts to Cover Plate Bolts, and tighten evenly, and in accordance with the tightening sequence indicated in Fig B of Appendix B, ensuring that Cover Plate lugs engage firmly with shoulders on Cover Plate Bolts.
- (iv) Complete the assembly of gland parts in the Stuffing Box or Expeller Ring, as described in Section 6.2 (Seal Assembly).
- (v) The pump is now ready for fitting of Joint Rings (refer 6.3.6) and Impeller adjustment (refer 6.4).

### 6.3.2 ELASTOMER LINERS - THREE PIECE

- Fitting Frame Plate Liner, Impeller, Throatbush, Cover Plate Liner, and Cover Plate
- Refer Figs 8, 10 and 13

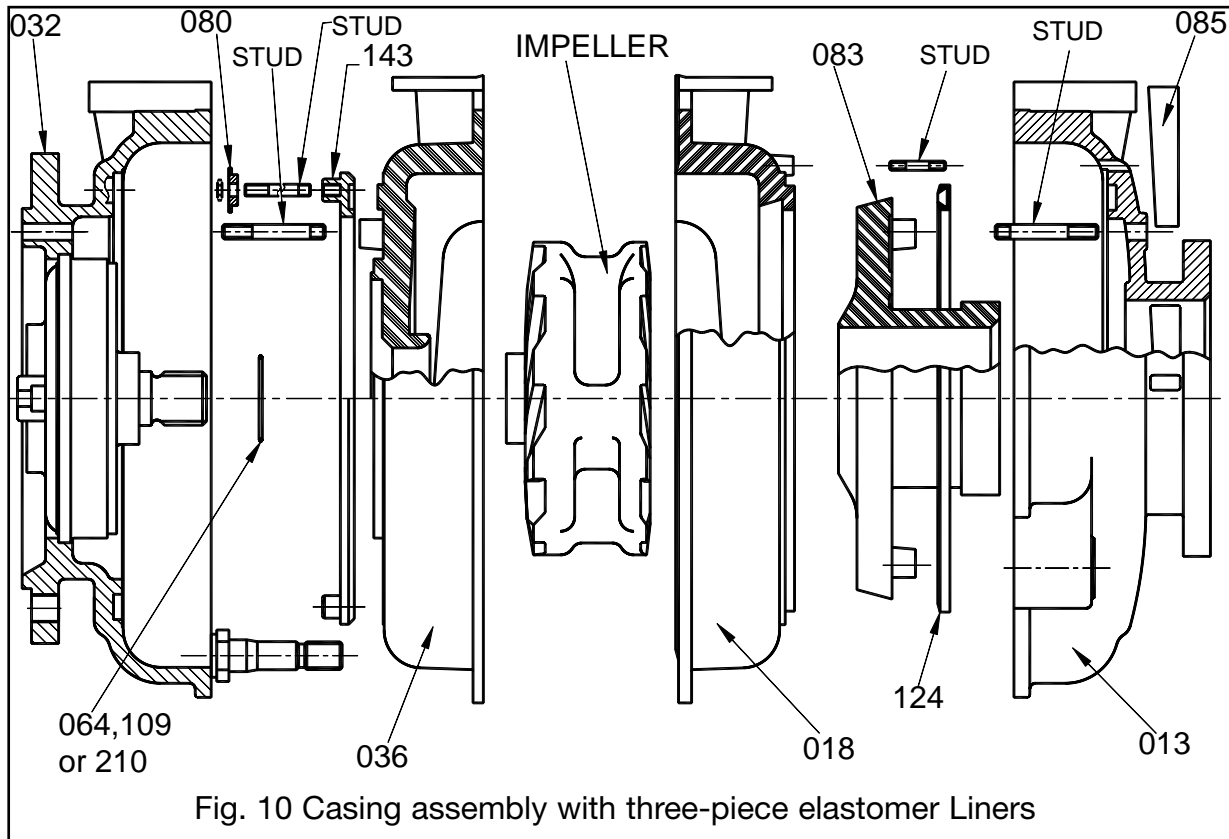

Intermediate size pumps are fitted with three elastomer casing liners, comprising Frame Plate Liner, Cover Plate Liner, and Throatbush. Pumps having Three-Piece elastomer liners comprise **sizes 6/4 AH, 8/6 AH, 10/8 AH, 12/10 AH, and 10/8 M**. The pump casing assembly, with Three-Piece elastomer liners, is described below.

**(i) For 10/8F-M pump only, fit SEAL HOLDER (143) as follows:**

Fit and tighten STUDS to tapped bosses on Seal Holder.

Lift Seal Holder, and position about Shaft axis with Studs adjacent FRAME PLATE (032), and aligned with holes in annular recess.

Push Seal Holder to engage outer diameter with corresponding diameter of annular recess in Frame Plate, with Studs engaging holes in recess.

Fit STEPPED WASHERS (080) to Studs, screw on nuts, and tighten uniformly.

**(ii) Fit FRAME PLATE LINER (036) as follows:**

- (a) Fit and tighten STUDS to tapped bosses in Frame Plate Liners. If Studs are not square to the face of the Liner, screw a nut on the thread, and adjust by tapping lightly with a hammer.

- (b) Lift Liner in position, lining up Studs with corresponding holes, and push into Frame Plate. Fit Nuts to Studs, and hand tighten sufficiently to hold Liner in its fitted position in Frame Plate.
  - (c) Restrain Shaft with wrench, and fit LOCATING NUT (303) on Shaft thread, as shown in Fig 8. Manually adjust the radial position of the Frame Plate Liner so that its inner diameter is approximately concentric with the conical surface of the Locating Nut. Tighten all Studs or Bolts on Frame Plate Liner finger tight plus half a turn (max), and remove Locating Nut.
- (iii) Fit IMPELLER as described below.
- (a) Fit SHAFT KEY (070) in Shaft keyway, and bolt SHAFT WRENCH (306) to Shaft, over key. Ensure that HEX HEAD BOLTS on Side 'B' of Base (refer Fig 13) are sufficiently tight to hold Bearing Assembly horizontal, but not lock it.
  - (b) Select IMPELLER, and apply anti-seize compound to thread. Lift Impeller with hoist, supported on a rope, and screw to Shaft.
  - (c) While restraining Shaft with Wrench, turn Impeller with a bar between vanes, and firmly screw Impeller to Shaft. Ensure that the various O-Rings on the Shaft are not damaged, and are covered by adjacent parts
- (iv) Fit COVER PLATE LINER (018), and THROATBUSH (083), as described below.

**(a) 6/4 AH, 8/6 AH, 10/8 AH, and 10/8 M Pumps only.**

In these pumps the LINER SEAL (124) is an integral part of the COVER PLATE LINER (018). Proceed with assembly as described below.

- (1) Place COVER PLATE LINER (018) on a flat surface, peripheral sealing flange down, and position a timber spacer, of sufficient height to finish flush or slightly above the Liner, in the centre of the Liner. Place the THROATBUSH (083), intake end upward, on the timber spacer.
- (2) Liberally apply liquid soap or rubber lubricant to the tapered periphery of the Throatbush, and the inner sealing lip of the Liner.
- (3) Lift Liner and tilt to engage lip seal over one third of the Throatbush periphery. Insert a small tyre lever, or similar, with rounded edges, between Throatbush and Liner, and lift seal lip to engage upper surface of Throatbush. Ensure that the seal lip is uniformly engaged.

**This operation should be carried out carefully to avoid damaging seal lip.**

Continue assembly instructions at Section (iv) (a) (5), below.



- (4) **For 10/8 AH pump only**, fit STUDS to tapped bosses in Throatbush.
- (5) **For all pumps, comprising 6/4 AH, 8/6 AH, 10/8 AH, 12/10 AH, and 10/8 M pumps**, lift COVER PLATE (013), intake flange upwards, and place over Throatbush and Liner, taking care to engage Studs in corresponding holes in Cover Plate, where applicable.
- (6) **For 6/4 AH, 8/6 AH, and 10/8 M pumps only**, insert COTTERS (085) through slots in neck of Cover Plate, and tap carefully and evenly until Throatbush is held firmly in Cover Plate.
- (7) **For 10/8 AH pump only**, screw Nuts to Studs in Throatbush, and tighten finger tight plus half a turn (max).

**(b) 12/10 AH Pump only.**

- (1) Place COVER PLATE (013) on suitable supports on a flat surface, intake flange down, to keep flange about 25mm above surface.
  - (2) Fit VOLUTE LINER SEAL (124) to groove in Cover Plate, mounted flat face in, using contact cement adhesive if required.
  - (3) Fit STUDS to tapped holes in THROATBUSH (083), align Studs with holes in Cover Plate, and lower Throatbush into place in Cover Plate. Fit Nuts to Studs, and hand tighten.
  - (4) Fit and tighten STUDS to tapped bosses in Cover Plate Liner. Fit Liner in Cover Plate, ensuring that Studs are engaged with corresponding holes in Cover Plate. Fit Nuts to Studs and tighten finger tight plus half a turn (max).
  - (5) Tighten Throatbush Studs finger tight plus half a turn (max).
- (v) Fit COVER PLATE (013).  
Lift Cover Plate, with Throatbush and Cover Plate Liner fitted, and align holes with COVER PLATE BOLTS (015) assembled in the Frame Plate. Note that large Cover Plates are provided with radially tapped holes for eyebolts, to assist lifting. Fit Nuts to Cover Plate Bolts, and tighten evenly, and in accordance with the tightening sequence indicated in Fig B of Appendix B, ensuring that Cover Plate lugs engage firmly with shoulders on Cover Plate Bolts.
- (vi) Complete the assembly of gland parts in the Stuffing Box or Expeller Ring, as described in Section 6.2 (Seal Assembly).
- (vii) The pump is now ready for fitting of Joint Rings (refer 6.3.6) and Impeller adjustment (refer 6.4).

### 6.3.3 ELASTOMER LINERS - FOUR PIECE

- Fitting Liner Seals, Frame Plate Liner Insert, Frame Plate Liner, Impeller, Throatbush, Cover Plate Liner, and Cover Plate.
- Refer Figs 8, 11 and 13.

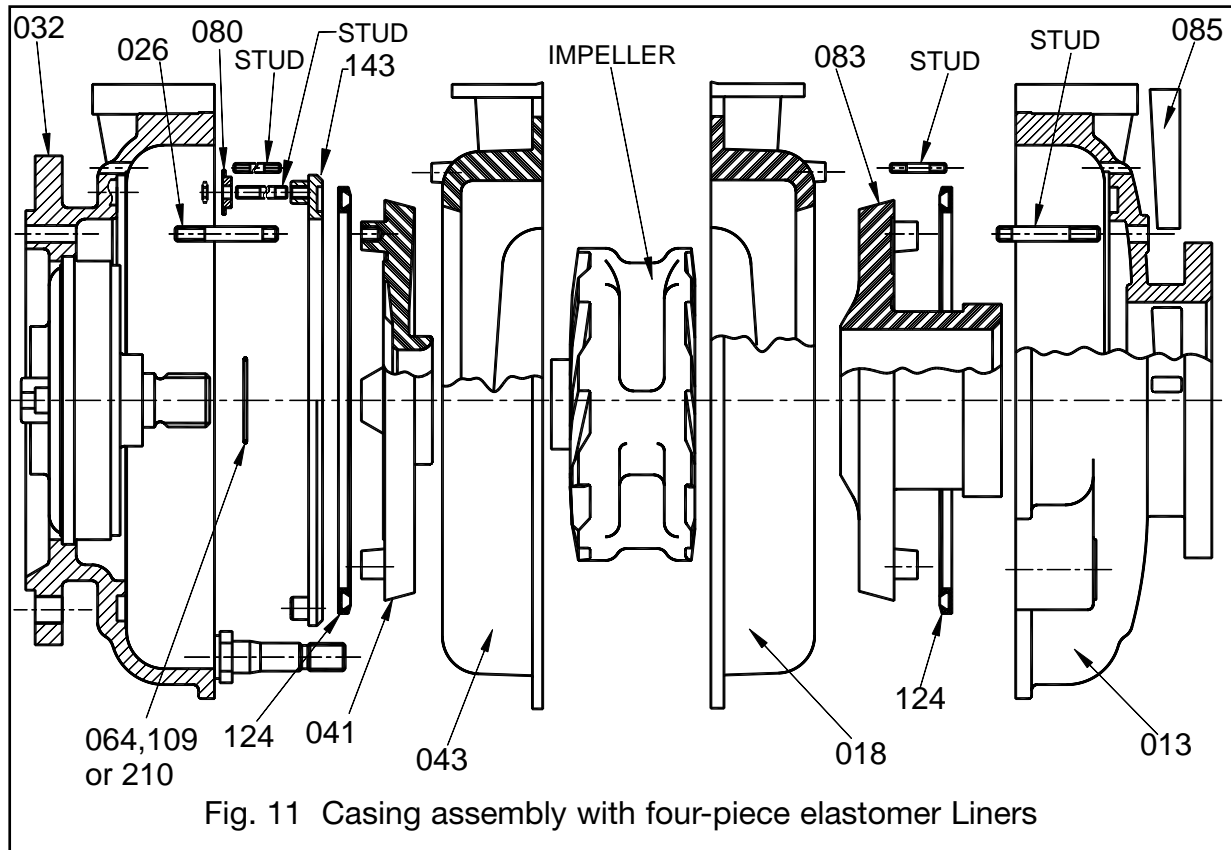

Fig. 11 Casing assembly with four-piece elastomer Liners

The larger size pumps are fitted with four elastomer casing liners, comprising Frame Plate Liner Insert, Frame Plate Liner, Cover Plate Liner, and Throatbush. Pumps having Four-Piece elastomer liners comprise **sizes 10/8F-R, 12/10F-R, 12/10 M, 14/12 AH, 16/14 AH, and 20/18 AH**. The pump casing assembly, with Four-Piece elastomer liners, is described below.

- (i) **For 10/8F-R pump only**, fit SEAL HOLDER (143) as follows:  
Fit and tighten STUDS to tapped bosses on Seal Holder.  
Lift Seal Holder, and position about Shaft axis with Studs adjacent FRAME PLATE (032), and aligned with holes in annular recess.  
Push Seal Holder to engage outer diameter with corresponding diameter of annular recess in Frame Plate, with Studs engaging holes in recess.  
Fit STEPPED WASHERS (080) to Studs, screw on nuts, and tighten uniformly.
- (ii) Fit VOLUTE LINER SEAL (124), FRAME PLATE LINER INSERT (041), and FRAME PLATE LINER (043) as follows:
  - (a) **14/12 AH, 16/14 AH, and 20/18 AH pumps only.**

- (1) Fit VOLUTE LINER SEAL (124) to groove in Frame Plate, mounted flat face in, using contact cement adhesive if required.
- (2) Fit and tighten STUDS to tapped bosses in FRAME PLATE LINER INSERT (041). If Studs are not square to face of Insert, screw a nut on thread, and adjust by tapping lightly with a hammer.
- (3) Suspend LIFTING TUBE (302) from a hoist (refer Fig 8). Stand Frame Plate Liner Insert on edge, and engage Lifting Tube in bore of Insert. Lift Tube with Insert attached, and slide tube over Shaft thread. Align Studs with holes, and push Insert against Frame Plate. Loosely fit nuts to Studs, and remove Lifting Tube.
- (4) Fit and tighten STUDS to tapped bosses in FRAME PLATE LINER (043).
- (5) Lift Frame Plate Liner with hoist, and place in position with Studs aligned with holes in Frame Plate. Push Liner onto Frame Plate to engage Studs with holes, and fit nuts.

**(b) 10/8F-R, 12/10F-R, and 12/10 M pumps only.**

- (1) Lift FRAME PLATE LINER (043) with hoist, and fit to Frame Plate. Apply liquid soap or rubber lubricant to inner surface Liner which engages with Frame Plate Liner Insert.
- (2) Fit and tighten STUDS to tapped bosses in FRAME PLATE LINER INSERT (041). If Studs are not square to the face of the Insert, screw a nut on the thread, and adjust by tapping lightly with a hammer.
- (3) Lift FRAME PLATE LINER INSERT (041) with hoist, and place in position with Studs aligned with holes in Frame Plate. Push Insert onto Frame Plate Liner to engage Studs with holes, and fit nuts finger tight only.

**(iii) Fit IMPELLER as follows:**

- (a) Fit SHAFT KEY (070) to Shaft keyway, and bolt SHAFT WRENCH (306) to Shaft, over key. Ensure that HEX HEAD BOLTS on Side 'B' of Base (refer Fig 13) are sufficiently tight to hold Bearing Assembly horizontal, but not clamp it.
- (b) Restrain Shaft with Wrench, and fit LOCATING NUT (303) on Shaft thread, as shown in Fig 8. The conical face will locate the Frame Plate Liner Insert in its correct radial position. Tighten all Studs (Frame Plate Liner Insert Studs, and/or Frame Plate Liner Studs), finger tight plus half a turn (max), and remove Locating Nut.
- (c) Select IMPELLER, and apply anti-seize compound to thread. Lift Impeller with hoist, supported on a rope, and screw to Shaft. While restraining Impeller, turn Shaft with Wrench to engage Impeller and Shaft

threads. Tighten Impeller on Shaft by placing bar between Impeller vanes, and firmly screw Impeller to Shaft.

Ensure that the various O-Rings on the Shaft are not damaged, and are covered by adjacent parts

(iv) Fit COVER PLATE LINER (018) and THROATBUSH (083) to COVER PLATE (013) as described below.

**(a) 14/12 AH, 16/14 AH, and 20/18 AH pumps only.**

- (1) Place COVER PLATE (013) on suitable supports on a flat surface, intake flange down, to keep flange about 25mm above surface.
- (2) Fit LINER SEAL (124) to groove in Cover Plate, mounted flat face in, using contact cement adhesive if required.
- (3) Fit STUDS to tapped holes in THROATBUSH (083), align Studs with holes in Cover Plate, and lower Throatbush into place in Cover Plate. Fit Nuts to Studs, and hand tighten.
- (4) Fit and tighten STUDS to tapped bosses in Cover Plate Liner. Fit Liner in Cover Plate, ensuring that Studs are aligned with corresponding holes in Cover Plate. Fit Nuts to Studs and tighten finger tight plus half a turn (max).
- (5) Tighten Throatbush STUDS finger tight plus half a turn (max).

**(b) 10/8F-R, 12/10F-R, and 12/10 M pumps only.**

- (1) Place COVER PLATE (013) on suitable supports on a flat surface, intake flange down, to keep flange about 25mm above surface.
- (2) Fit COVER PLATE LINER (018) to COVER PLATE (013), and apply liquid soap or rubber lubricant to recess in Liner which engages with Throatbush.
- (3) Lower THROATBUSH (083) into Cover Plate, and push down firmly to engage with Cover Plate Liner.
- (4) Insert COTTERS (085) through slots in neck of Cover Plate, and tap carefully and evenly until the Throatbush is held firmly in the Cover Plate.

(v) Fit COVER PLATE (013).

Lift Cover Plate, with Throatbush and Cover Plate Liner fitted, and align holes with Cover Plate Bolts (015) assembled in the Frame Plate.

Note that large Cover Plates are provided with radially tapped holes for eye bolts, to assist lifting.

Fit Nuts to Cover Plate Bolts, and tighten evenly, and in accordance with the tightening sequence indicated in Fig B of Appendix B, ensuring that Cover Plate lugs engage firmly with shoulders on Cover Plate Bolts.

(vi) Complete the assembly of gland parts in the Stuffing Box or Expeller Ring, as described in Section 6.2 (Seal Assembly).

(vii) The pump is now ready for fitting of Joint Rings (refer 6.3.6) and Impeller adjustment (refer 6.4).

### 6.3.4 METAL LINERS - TWO PIECE

- Fitting Seal Rings, Frame Plate Liner Insert, Volute Liner Seals, Volute Liner, Impeller and Cover Plate
- Refer Figs 8, 12, and 13

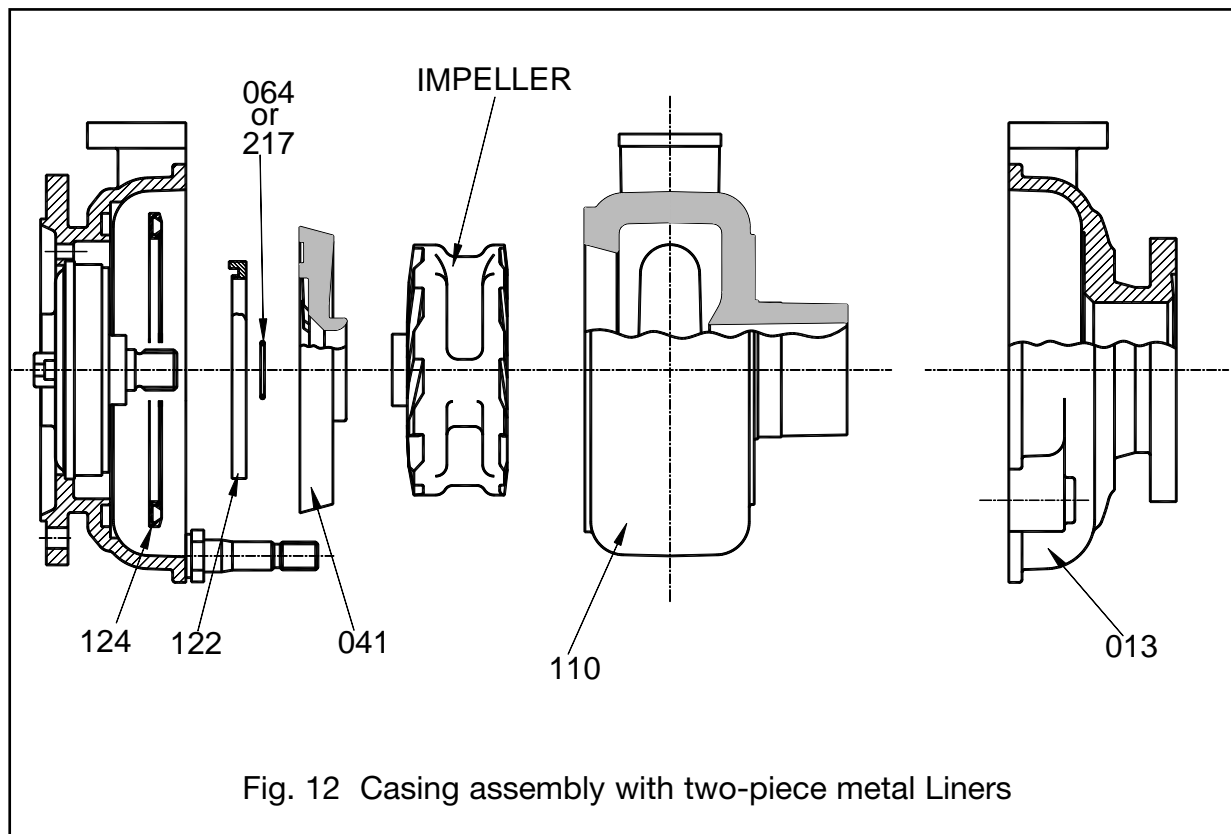

Fig. 12 Casing assembly with two-piece metal Liners

In Two Piece metal lined pumps, a separate Throatbush is not provided, this part being combined with the Volute Liner as a single composite liner. This applies **to pump sizes 1.5/1 AH, 2/1.5 AH, 3/2 AH, and 4/3 AH**. The pump casing assembly, with Two-Piece metal liners, is described below.

(i) Fit 'C'-section SEAL RING (122) to periphery of Stuffing Box or Expeller Ring, preferably using contact cement adhesive. Apply adhesive to compression face of Seal Ring in about 4 to 6 points only to avoid undue restraint of Seal during compression.

- (ii) Fit VOLUTE LINER SEAL (124 or 125), which is one of two types:
- (a) O-Ring Type: VOLUTE FRAME SEAL (125).  
- **Pump sizes 1.5/1 AH, 2/1.5 AH, and 3/2 AH.** This Seal is fitted at a later stage (refer to (iii)(a)(5) below)
- (b) 'C'-Section Type: VOLUTE LINER SEAL (124) - **4/3 AH Pump.**  
Fit to groove in the Frame Plate, mounted flat face in, using contact cement adhesive if required.

(iii) Fit FRAME PLATE LINER INSERT (041) and IMPELLER.  
The Frame Plate Liner Insert is clamped in position by engagement of its conical periphery with a corresponding conical surface on the VOLUTE LINER (110). Radial alignment of the Insert is provided by engagement of a spigot on the Insert with a recess in the Frame Plate (**1.5/1 AH, 2/1.5 AH, and 3/2 AH pumps**). In the 4/3 AH pump, radial alignment of the Insert is provided only by engagement with the Volute Liner.

**(a) 1/5/1 AH, 2/1.5 AH, and 3/2 AH Pumps only.**

- (1) Place IMPELLER (thread up) on a flat surface, and apply anti-seize compound to thread.

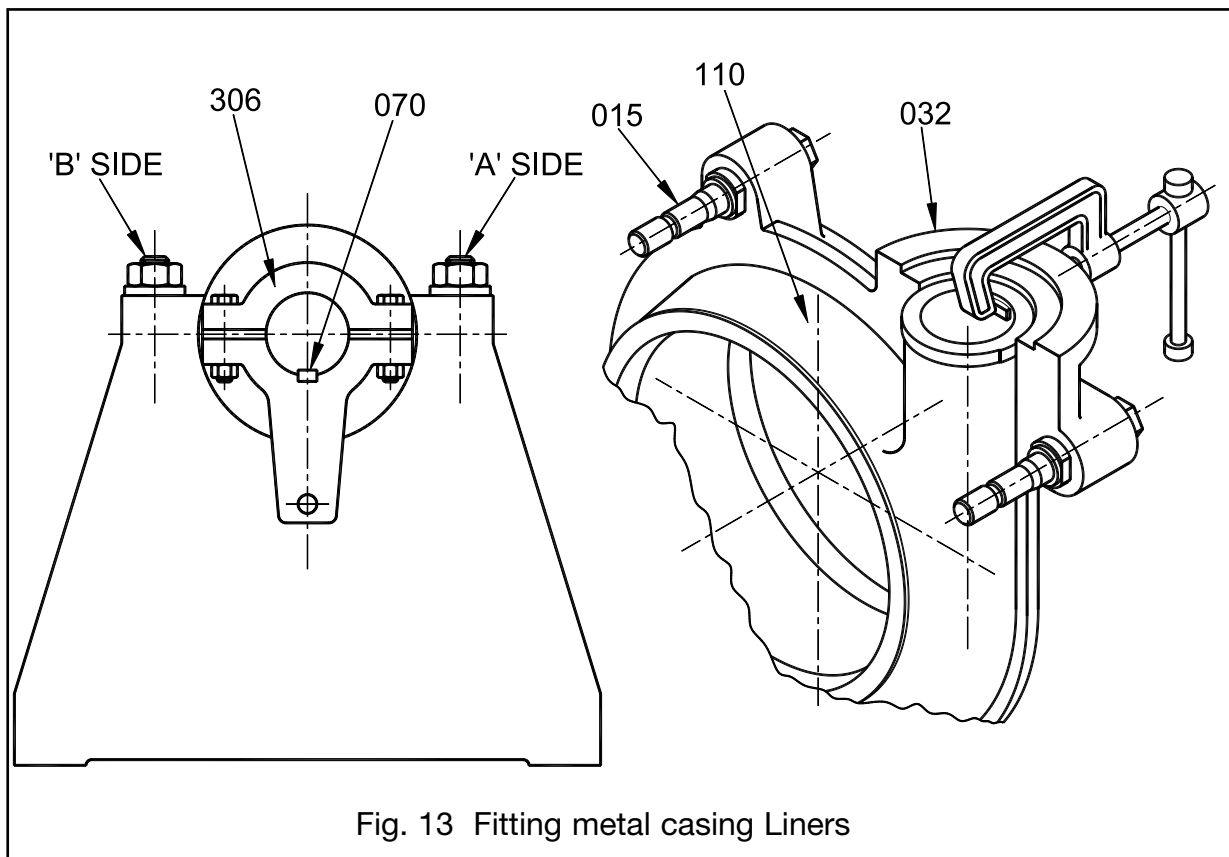

- (2) Place FRAME PLATE LINER INSERT (041) over Impeller boss, with Insert vanes away from Impeller, and screw Impeller to Shaft. Ensure that the various Seals are not displaced, and that the spigot on the back face of the Frame Plate Liner Insert engages with the Frame Plate bore.
- (3) Fit SHAFT KEY (070) in Shaft keyway, and bolt SHAFT WRENCH (306) to Shaft, over key. While restraining Shaft with Wrench and turning Impeller with a bar between vanes, firmly screw Impeller to Shaft, but do not overtighten.
- (4) Ensure that HEX HEAD BOLTS on Side 'B' of Base (refer Fig 13) are sufficiently tight to hold Bearing Assembly horizontal, but not lock it. Move Bearing Assembly back by adjusting nut on Adjusting Screw (001) to temporarily clamp Frame Plate Liner Insert in its correct position.
- (5) Fit O-Ring type VOLUTE FRAME SEAL (125) over periphery of Frame Plate Liner Insert, and adjacent Frame Plate.

**(b) 4/3 AH Pump only.**

- (1) Place IMPELLER (thread up) on a flat surface, and apply anti-seize compound to thread.
- (2) Place FRAME PLATE LINER INSERT (041) over Impeller boss, with Insert vanes away from Impeller, and screw Impeller to Shaft. Ensure that the various Seals are not displaced.
- (3) Fit SHAFT KEY (070) in Shaft keyway, and bolt SHAFT WRENCH (306) to Shaft, over key. While restraining Shaft with Wrench and turning Impeller with a bar between vanes, firmly screw Impeller to Shaft, but do not overtighten.
- (4) Ensure that HEX HEAD BOLTS on Side 'B' of Base (refer Fig 13) are sufficiently tight to hold Bearing Assembly horizontal, but not lock it. Move Bearing Assembly back by adjusting nut on Adjusting Screw (001) to temporarily clamp Frame Plate Liner Insert in its correct position.

**(c) 1/5/1 AH, 2/1.5 AH, 3/2 AH, and 4/3 AH Pumps.**

- (iv) Fit VOLUTE LINER (110) - Place Volute Liner around Impeller, and move back towards Frame Plate until the conical bore engages with the matching periphery of the Frame Plate Liner Insert. Ensure that the Volute Liner Seal (O-Ring) has not been displaced. Fit a G clamp to temporarily clamp the Volute Liner discharge nozzle to the flange of the Frame Plate, as shown in Fig 13.

**ENSURE THAT THE VOLUTE LINER IS FIRMLY CLAMPED DURING ASSEMBLY TO PREVENT INJURY TO PERSONNEL.**

(v) Lift COVER PLATE (013) over Volute Liner and align bolt holes with Cover Plate Bolts fitted to Frame Plate. Fit nuts to Cover Plate Bolts, and leave loose. Remove G clamp supporting Volute Liner, and tighten Cover Plate bolts evenly to torque values not less than indicated in Table 1, and in accordance with the tightening sequence indicated in Fig B of Appendix B, ensuring that Cover Plate lugs engage fully with shoulders on Cover Plate Bolts. If a torque wrench, or equivalent device is not available, bolts should be tightened in accordance with the procedure and sequence as described and indicated in Appendix B.

(vi) Complete the assembly of gland parts in the Stuffing Box or Expeller Ring, as described in Section 6.2 (Seal Assembly).

(vii) The pump is now ready for fitting of Joint Rings (refer 6.3.6) and Impeller adjustment (refer 6.4).

### 6.3.5 METAL LINERS - THREE PIECE

- Fitting Seal Ring, Frame Plate Liner Insert, Volute Liner Seals, Volute Liner, Impeller, Throatbush, and Cover Plate
- Refer Figs 8, 13, and 14

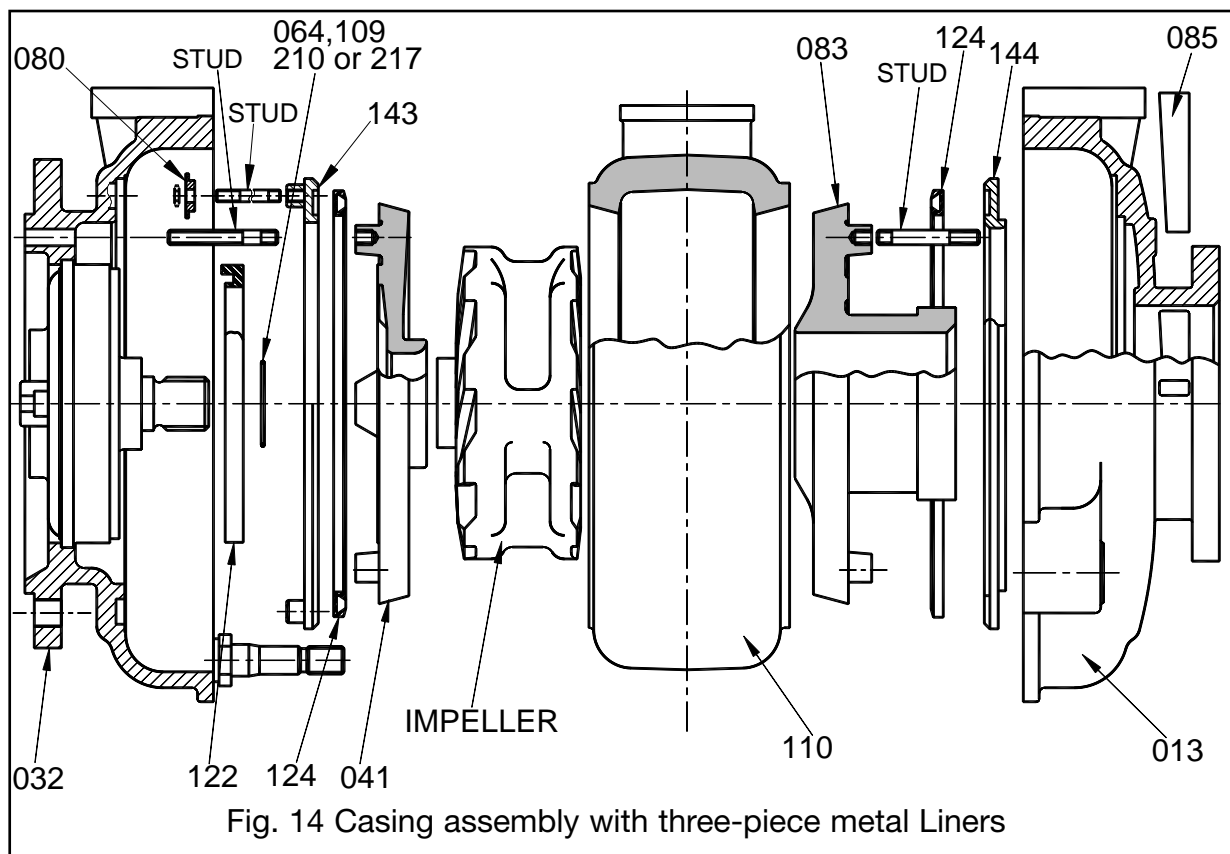

In Three Piece metal lined pumps, a separate Throatbush is provided, independent of the Volute Liner. This applies to pump sizes **6/4 AH and larger**.



(i) Fit SEAL RING (122) to Stuffing Box or Expeller Ring. The Seal Ring may be one of two types:

(a) 'C' Section Seal Ring: **Pump sizes 6/4 AH and 8/6 AH.**

Fit 'C'-section SEAL RING (122) to periphery of Stuffing Box or Expeller Ring, preferably using contact cement adhesive. Apply adhesive to compression face of Seal Ring in about 4 to 6 points only to avoid undue restraint of Seal during compression.

(b) O-Ring Type Seal Ring: **Pump sizes above 8/6 AH.**

Fit Seal to groove on the compression face on the periphery of the Stuffing Box or Expeller Ring.

(ii) **For 10/8F-M, 12/10E-M, and 12/10F-M pumps only,** fit SEAL HOLDER (143) as follows:

Fit and tighten STUDS to tapped bosses on Seal Holder.

Lift Seal Holder, and position about Shaft axis with Studs adjacent FRAME PLATE (032), and aligned with holes in annular recess.

Push Seal Holder to engage outer diameter with corresponding diameter of annular recess in Frame Plate, with Studs engaging holes in recess.

Fit STEPPED WASHERS (080) to Studs, screw on nuts, and tighten uniformly.

(iii) Fit VOLUTE LINER SEAL (124). This is a 'C'-Section pressure activated Seal. Fit to groove in the Frame Plate, or Seal Holder if applicable, mounted flat face in, using contact cement adhesive if required.

(iv) Fit FRAME PLATE LINER INSERT (041) and IMPELLER.

The Frame Plate Liner Insert is fixed to the Frame Plate by means of Studs.

(a) Firmly fasten STUDS in tapped holes on Frame Plate Liner Insert.

(b) Suspend LIFTING TUBE (302) from a hoist (refer Fig 8). Stand Frame Plate Liner Insert on edge, and engage Lifting Tube in bore of Insert. Lift Tube with Insert attached, and slide tube over Shaft thread. Align Studs with holes, and push Insert against Frame Plate. Ensure that the Seals (122 and 124) have not been displaced. Fit nuts to Studs, and leave loose. Remove Lifting Tube.

(c) Fit SHAFT KEY (070) in Shaft keyway, and bolt SHAFT WRENCH (306) to Shaft, over key. Ensure that HEX HEAD BOLTS on Side 'B' of Base (refer Fig 13) are sufficiently tight to hold Bearing Assembly horizontal, but not lock it.

Restrain Shaft with Wrench, and fit LOCATING NUT (303) on Shaft thread, as shown in Fig 8. The conical face will locate the Frame Plate Liner Insert in its correct radial position. Fully tighten all Studs on Insert, and remove Locating Nut.

- (d) Ensure that O-Ring (109 or 064) at end of the Expeller or Shaft Spacer is positioned in its locating groove.
- (e) Select IMPELLER, and apply anti-seize compound to thread. Lift Impeller with hoist, supported on a rope, and screw to Shaft. While restraining Impeller, turn Shaft with Wrench to engage Impeller and Shaft threads. Tighten Impeller on Shaft, with bar between Impeller vanes, by flogging Shaft Wrench. Ensure that the various O-Rings on the Shaft are not damaged, and are covered by adjacent parts.
- (v) Fit VOLUTE LINER (110) to Frame Plate as described below.
  - (a) Lift VOLUTE LINER (110) using VOLUTE LIFTING BEAM (304) and hoist, as shown in Fig 8. Place Volute Liner around Impeller, and move back towards Frame Plate until the conical bore engages with the matching periphery of the Frame Plate Liner Insert. Check that the Volute Frame Seal has not displaced.
  - (b) Fit a G clamp to temporarily clamp the Volute Liner discharge nozzle to the flange of the Frame Plate, as shown in Fig 13.

**ENSURE THAT THE VOLUTE LINER IS FIRMLY CLAMPED DURING ASSEMBLY TO PREVENT INJURY TO PERSONNEL.**

- (c) Lugs are provided around the Volute Liner periphery in large pumps. These lugs are positioned to engage some Cover Plate Bolts provided with special slots or KEEPER PLATES (081). These Cover Plate Bolts were described in Section 6.1.2.

**Fit these COVER PLATE BOLTS (015) to the Frame Plate to support the Volute Liner during subsequent pump assembly stages.**

Ensure that for each Bolt with a slot, the slot engages the Volute lug before tightening. For Bolts with Keeper Plates, slide the Keeper Plate over the Cover Plate Bolt on to the spigot diameter on the bolt centre section, and push Bolts through Frame Plate such that the Keeper Plate is closest to the Frame Plate, bends away from it, and engages the lug on the Volute Liner.

- (vi) **For 12/10E-M and 12/10F-M pumps only** - fit SEAL HOLDER (143) as follows:  
Lift Seal Holder, and position about Shaft axis with flat face adjacent COVER PLATE (013).  
Push Seal Holder to engage inner spigot diameter with corresponding recess in Cover Plate.
- (vii) Fit THROATBUSH (083) to COVER PLATE (013).
  - (a) Place COVER PLATE (013) on suitable supports on a flat surface, intake flange down, to keep flange about 25mm above surface.

- (b) Fit VOLUTE LINER SEAL (124) to groove in Cover Plate, or Seal Holder if applicable, mounted flat face in, using contact cement adhesive if required.
  - (c) If applicable, fit STUDS to tapped holes in THROATBUSH (083) and leave finger tight at this stage **(for 12/10 AH pumps and larger)**.
  - (d) Lower THROATBUSH (083) into Cover Plate.
  - (e) If applicable, insert COTTERS (085) through slots in neck of Cover Plate, and tap carefully and evenly until the Throatbush is held firmly in the Cover Plate **(for 6/4 AH to 10/8 AH, 10/8 M and 12/10 M pump sizes only)**. Do not fix Cotters firmly at this stage.
- (viii) Lift COVER PLATE (013) with hoist, place over Volute Liner, and align bolt holes with Cover Plate Bolts fitted to Frame Plate. Fit nuts to Cover Plate Bolts, and leave loose. Remove G clamp supporting Volute Liner, and tighten Cover Plate bolts evenly to torque values not less than indicated in Table 1, and in accordance with the tightening sequence indicated in Fig B of Appendix B, ensuring that Cover Plate lugs engage fully with shoulders on Cover Plate Bolts. If a torque wrench, or equivalent device is not available, bolts should be tightened in accordance with the procedure and sequence as described and indicated in Appendix B.
- (ix) Fully tighten all Throatbush Cotters and Studs.
  - (x) Complete the assembly of gland parts in the Stuffing Box or Expeller Ring, as described in Section 6.2 (Seal Assembly).
  - (xi) The pump is now ready for fitting of Joint Rings (refer 6.3.6) and Impeller adjustment (refer 6.4).

### 6.3.6 MISCELLANEOUS FITTINGS

- Refer Fig 15

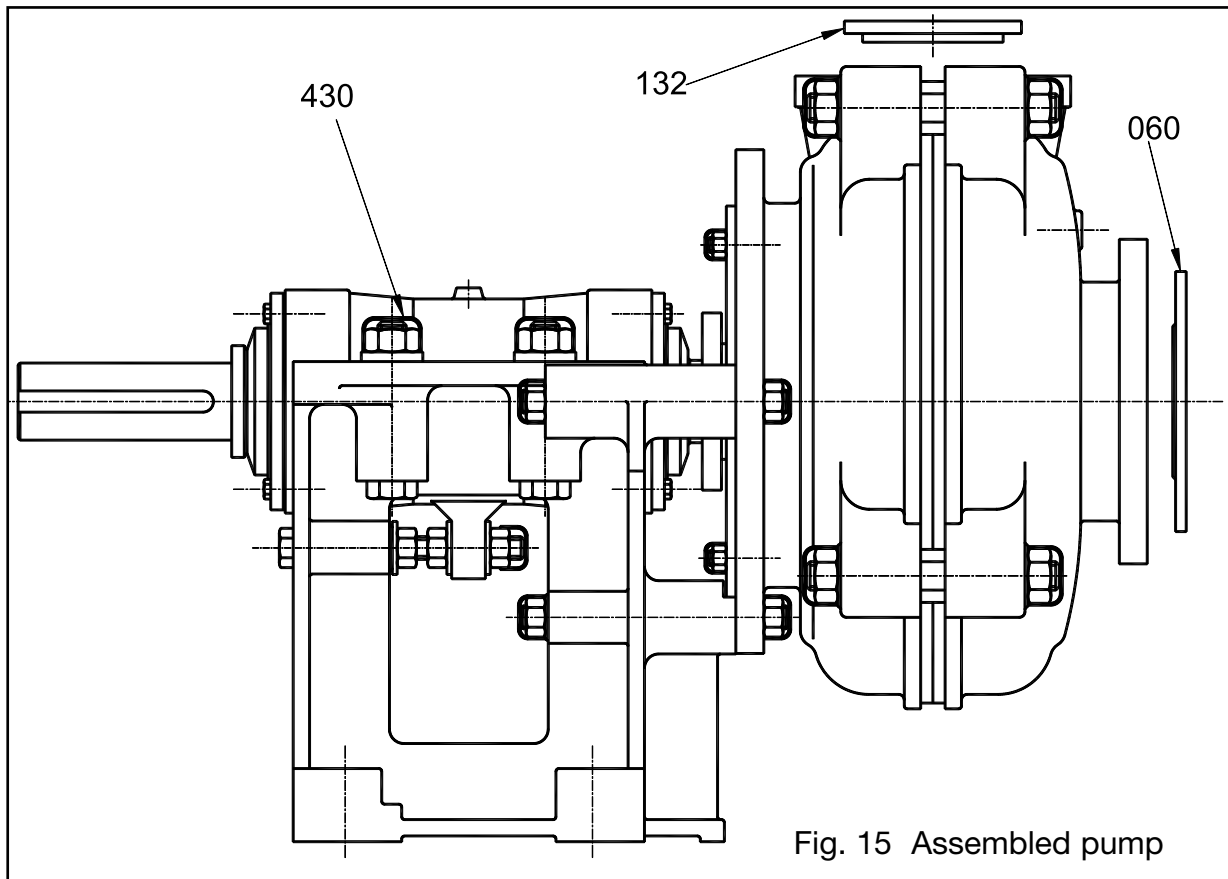

Fig. 15 Assembled pump

The pump assembly is now substantially complete, and requires only fitting of miscellaneous external components.

- (i) The INTAKE JOINT RING (060) and DISCHARGE JOINT RING (132) are supplied loose with pumps requiring these items. Fit Intake Joint Ring and Discharge Joint Ring as shown in Fig 15, using contact cement adhesive to provide support during fitting of intake and discharge pipework.
- (ii) Fit piping from Drip Tray in BASE (003), if fitted, to convey leakage from gland seal.
- (iii) Fit elastomer NUT COVERS (430) to all external nuts to prevent fouling of threads with slurry.

## 6.4 IMPELLER ADJUSTMENT

- Refer Figs 13 and 16.

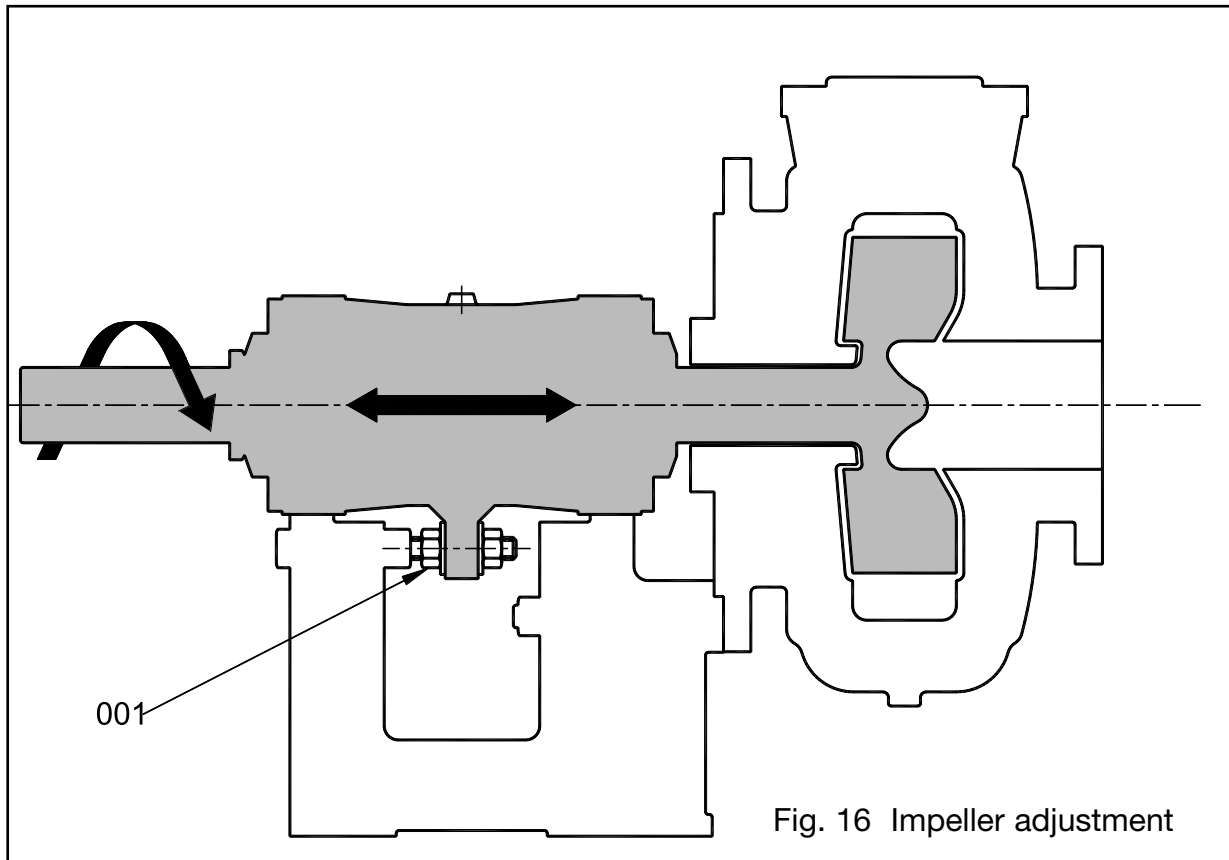

Fig. 16 Impeller adjustment

### (a) Initial Adjustment

With a Gland Seal assembly fitted, both Rubber and Metal Lined Pumps should be adjusted to operate with the Impeller having minimum axial clearance with the front casing liner (Throatbush or Cover Plate Liner). This is most important with High Efficiency Impellers.

Adjustment of Impeller front-end clearance is carried out as follows:

- Rotate the Shaft clockwise (as viewed from the drive end) by hand, and move the Bearing Assembly forward (towards the pump intake) by adjusting the rear nut on the ADJUSTING SCREW (001) until the Impeller rubs on the front Liner.
- Unscrew the rear nut by one sixth of a turn, and move the Bearing Assembly back by adjustment of the front nut on the Adjusting Screw until the lug on the Bearing Assembly contacts the rear nut. Fully tighten the front nut to secure the Bearing Assembly in position.

- (iii) Ensure that the Shaft can now rotate freely without contact of the Impeller with the front Liner. If contact occurs, repeat step (ii).

**NOTE:** *After each Impeller adjustment is completed, the BEARING HOUSING CLAMP BOLTS must be tightened to torque values indicated in Table 5, below. If a torque wrench, or equivalent device is not available, bolts should be tightened in accordance with the procedure as described in Appendix B.*

With a Centrifugal Seal or SuperSeal assembly fitted, the pump should be adjusted to operate with the Impeller having approximately equal axial clearance with the front and rear casing liners.

With a Dyna Seal assembly fitted, the pump should be adjusted to operate with the Impeller having minimum axial clearance with the rear casing liner.

If leakage occurs from the Centrifugal, SuperSeal or Dyna Seals during pump operation, the Impeller should be adjusted rearwards to minimise axial clearance between the Impeller and rear casing liner. If seal leakage persists after Impeller adjustment, this indicates that the intake pressure is excessive for the Impeller fitted. Leakage may be prevented by fitting of an alternative Impeller having improved intake pressure sealing characteristics. This may require fitting of a differential Impeller.

#### **(b) Periodic Adjustment**

Periodic adjustment of Impeller clearance over its operating life is an important factor in maximising wear life of both Impeller and front Liner. Extensive field experience has shown that an increase in wear life of up to 50 percent can be achieved by regular Impeller adjustment, compared with pumps not subject to initial or ongoing adjustment. Regular Impeller adjustment has shown an increase in wear life of typically 20 percent compared with pumps subjected only to initial adjustment.

The recommended procedure for periodic Impeller adjustment is as follows:

- (i) At initial pump assembly, adjust Impeller to “just clear” the Throatbush or front Liner, as described in (a).
- (ii) After 50 to 100 hours of pump operation, re-adjust Impeller front-end clearance.
- (iii) Re-adjust Impeller front-end clearance a further two or three times at regular intervals over its wear life. This may coincide with regular pump maintenance intervals, typically 500 hours.

**NOTE:** *After each Impeller adjustment is completed, the BEARING HOUSING CLAMP BOLTS must be tightened to torque values indicated in Table 5, below. If a torque wrench, or equivalent device is not available, bolts should be tightened in accordance with the procedure as described in Appendix B.*

**TABLE 5  
TIGHTENING TORQUE  
FOR BEARING HOUSING CLAMP BOLTS**

Frame Size	Minimum Torque (N m)
A & B	10
C & D	45
E & F	185
G	325
H	1500

## 7. DISMANTLING PUMP AND REMOVAL OF IMPELLER

The procedure for dismantling the pump is generally the reverse of that described for pump assembly, with the exception of Impeller removal on large pumps.

Access to the IMPELLER requires removal of the COVER PLATE (013), THROATBUSH (083), COVER PLATE LINER (017, 018) (elastomer lined casing), and VOLUTE LINER (110) (metal lined casing). These parts may be withdrawn after removal of nuts on the COVER PLATE BOLTS (015).

Impellers are fitted to Shafts with a right hand screw thread attachment on all Warman pumps. Impeller removal generally involves applying an impulsive torque loading to the Impeller, while separately restraining the Shaft from rotation. IMPELLER RELEASE COLLARS (239) are fitted to Shafts of large pumps to assist Impeller removal. The Impeller Release Collar is first removed, to relieve compressive loading on the Impeller hub, allowing the Impeller to be readily unscrewed from the Shaft.

Instructions for using IMPELLER RELEASE COLLARS (239) are presented in Warman Manual Part 4A, Impeller Release Collar.

## APPENDIX A

## WARMAN BASIC PART NUMBERS

WARMAN BASIC PART No.	STANDARD WARMAN MATERIAL CODE	PART NAME
001	E62	Adjusting Screw
003	G01	Base
005	-	Bearing Assembly
011	E62	Clamp Washer
013	D20	Cover Plate
015	E62	Cover Plate Bolt
017	R26A	Cover Plate Liner
018	R26A	Cover Plate Liner (Half)
024	E62	End Cover
028	G01	Expeller
029	G01	Expeller Ring
029R	R08A	Expeller Ring (Rubber)
032	D20	Frame Plate
034	E62	Frame Plate Bolt
036	R26A	Frame Plate Liner
039	E63	Frame Plate Stud
041	A05A, R26A	Frame Plate Liner Insert
043	R26A	Frame Plate Liner (Half)
044	K24	Gland Assembly
060	R08A	Intake Joint
062	D70	Labyrinth
063	K31	Lantern Ring
064	S18	Impeller O-Ring
067	E62	Neck Ring
070	E05	Shaft Key
073	E05	Shaft
075	D20	Shaft Sleeve
076	D20	Shaft Sleeve (Long)
078	G01	Stuffing Box
081	E02	Keeper Plate
083	A05A, R26A	Throatbush
085	E02	Cotter
090	S10	Lip Seal
109	S18	Shaft O-Ring



## APPENDIX A

## WARMAN BASIC PART NUMBERS (Cont.)

WARMAN BASIC PART No.	STANDARD WARMAN MATERIAL CODE	PART NAME
110	A05A	Volute Liner
111	Q05	Packing
117	E62	Shaft Spacer
118	K31	Lantern Restrictor
118-1	K24	Lantern Restrictor (Low Flow))
122	R11A	Expeller Ring/Stuffing Box Seal
124	R08A	Volute Liner Seal
125	R08A	Volute Frame Seal
132	R08A	Discharge Joint Ring
138	E62	Grease Cup Adaptor
179	C23	Shaft Sleeve Spacer
210	S46	Shaft O-Ring
217	S18	Impeller O-Ring
239	C23	Impeller Release Collar
241	K24	Lip Seal Gland
302	E02	Lifting Tube
303	E02	Locating Nut
304	E02	Volute Lifting Beam
306	E02	Shaft Wrench
310	E02	Stuffing Box/Expeller Ring Lifting Beam
425	R08A	Dyna Seal
430	U14	Nut Covers
-	-	Grease Cup
-	-	Grease Nipple
-	-	Hex Head Bolt
-	-	Square Head Set Screw
-	-	Stud

**NOTE** – Refer to Appendix B of Part 1 of the Instruction Manual for details of Warman Material Codes.

**APPENDIX B****ALTERNATIVE BOLT TIGHTENING PROCEDURE**

In situations where a torque wrench or equivalent device is not available, bolts should be tightened in accordance with the following procedure, described as the “Turn-of-the-nut method”, which is consistent with SABS Standard SABS 094 -1982.

Bring the parts of the joint into full contact by tightening sufficient bolts to achieve a “snug-tight” condition. The “snug-tight” condition is described to be 10% of the bolt’s full tension or yield tension. This is achieved to reasonable accuracy and repeatability by the full effort of an average man (approximately 70kg) using a standard podger spanner, or by a few impacts from an impact wrench, after initial slackness in the nut has been taken up.

Make corresponding permanent marks on the nut and the protruding thread of the bolt, from which subsequent rotation of the nut or bolt can be measured.

Then using the appropriate turns in Table B, turn the bolts/nuts, according to the tightening sequence shown in Figure B, if appropriate, to achieve 70% of yield tension in the bolts.

**TABLE B**

<b>Bolt Size (mm)</b>	<b>Shank Length Between Load Faces Of Bolt and Nut (mm)</b>	<b>Final Torsional Displacement Between Bolt and Nut (turns)</b>
M16 – M22	<120	0.5
	>120	0.75
M24 – M36	<160	0.5
	>160	0.75
M38 – M64	<200	0.5
	>200	0.75

**APPENDIX B**

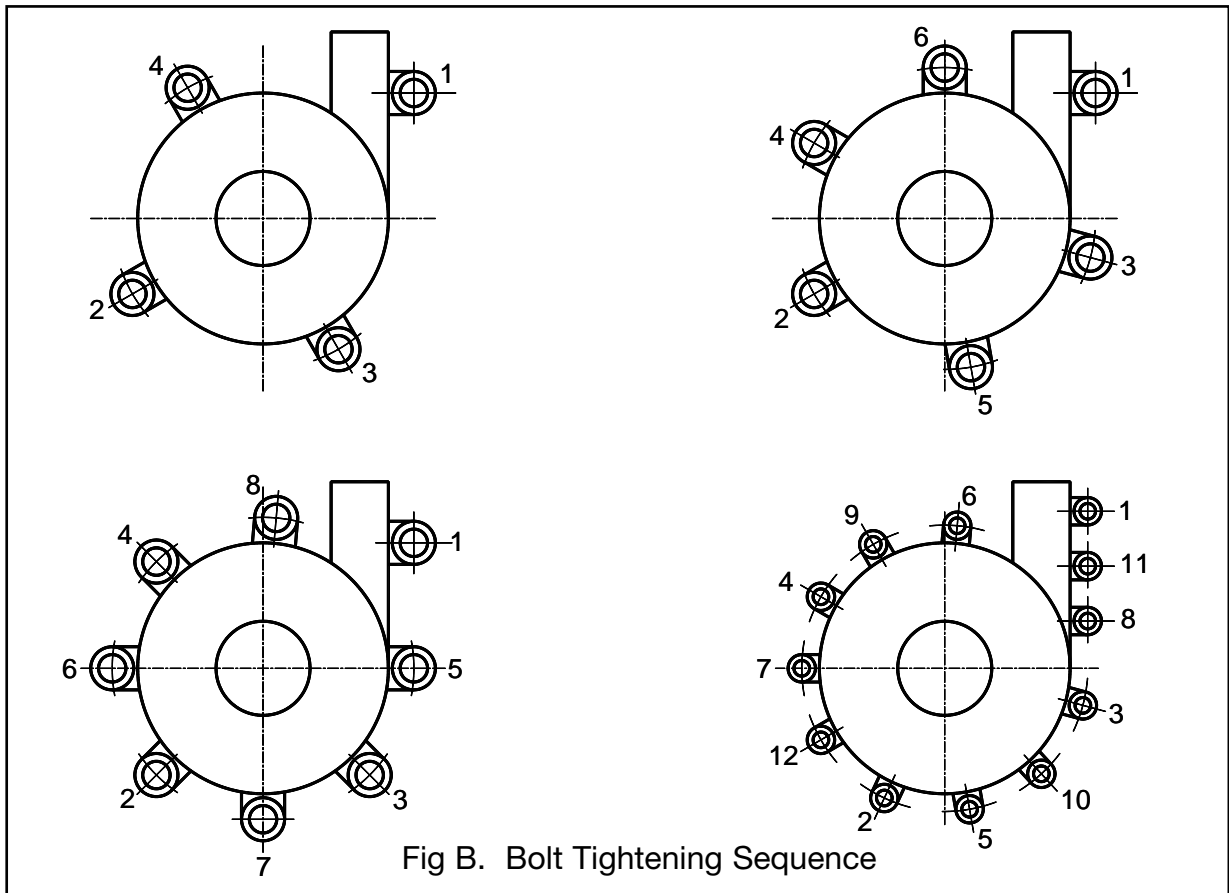

## APPENDIX C

### GLAND SEALING WATER FLOWRATE

Alternative Stuffing Box gland packing configurations may be used depending on the particular pump application, as shown in Fig 4, with each one having different gland sealing water flowrates.

Fig 4(a) shows the Full Flow Water Seal arrangement, with a metal Lantern Restrictor, being suitable for positive intake head and small suction lifts. This seal arrangement has maximum gland sealing water consumption.

The Low Flow Water Seal arrangement shown in Fig 4(b) has a close fitting Lantern Restrictor, and is suitable for high suction lift applications. Gland sealing water flowrates for this sealing option are about thirty percent of that shown in Fig 4(a).

The Ultra Low Flow Water Seal arrangement shown in Fig 4(c) has a ring of packing between the Lantern Ring and the pump casing interior to limit gland sealing water flowrate to a very small value, typically about one percent of that shown in Fig 4(a). This type of sealing arrangement is used where only very small quantities of gland water addition to the pumped fluid can be tolerated, eg in alumina process pumping applications.

Recommended values of gland sealing water flowrates to be provided are shown in Table C. These flowrates include a provision for wear, which progressively reduces the velocity of sealing water issuing from Stuffing Box chamber into the pump casing, and the corresponding effectiveness of excluding solid particles from the packed gland.

**TABLE C**  
**GLAND SEALING WATER FLOWRATE**

Pump Size	Flowrate - L/min		
	Full Flow	Low Flow	Ultra Low Flow
1.5/1B-AH	18	6	0.3
2/1.5B-AH	18	6	0.3
3/2C-AH	36	11	0.45
4/3C-AH	36	11	0.45
4/3D-AH	54	15	0.75
6/4D-AH	54	15	0.75
6/4E-AH	72	21	0.75
8/6E-AH	72	21	0.75
10/10E-L	72	21	0.75
10/8E-M	72	21	0.75
12/10E-M	72	21	0.75
8/6F-AH	90	23	1.5
10/8F-AH	135	40	1.5
10/8F-M, 200F-M	90	23	1.5
12/10F-AH	135	40	1.5
12/10F-M, 250F-L	90	23	1.5
12/12F-AH	135	40	1.5
14/12F-AH	135	40	1.5
10/8G-AH	135	40	1.5
12/10G-AH	135	40	1.5
12/12G-AH	135	40	1.5
14/12G-AH	135	40	1.5
16/14G-AH	135	40	1.5
20/18G-AH	155	45	1.8
16/14H-AH	197	55	2.3
20/18H-AH	180	50	2.1

**NOTE** - Refer to Fig 4 for alternative gland arrangements corresponding with FULL FLOW, LOW FLOW, and ULTRA LOW FLOW Stuffing Box configurations.