

ASSEMBLY

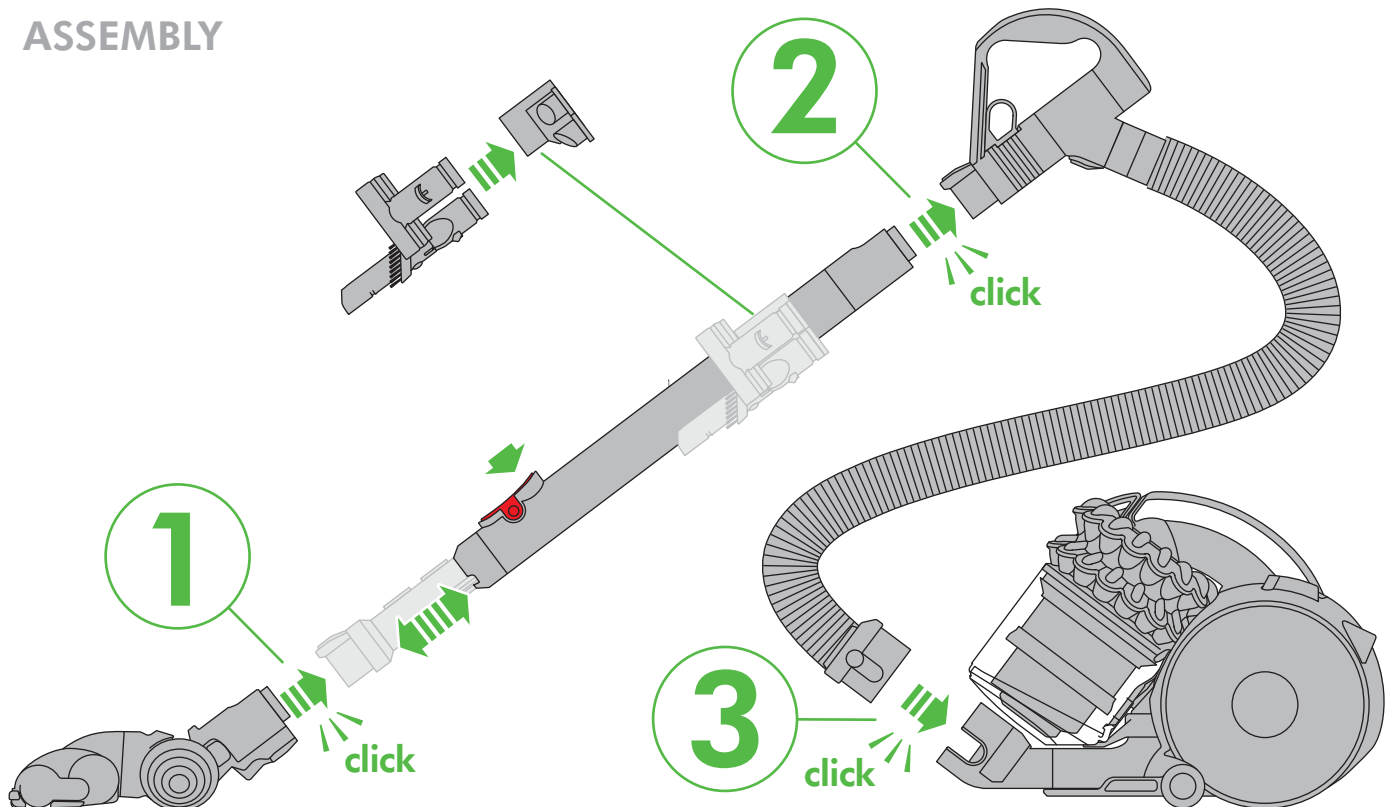

**WASH FILTERS**  
Wash filters with cold water regularly or as required.

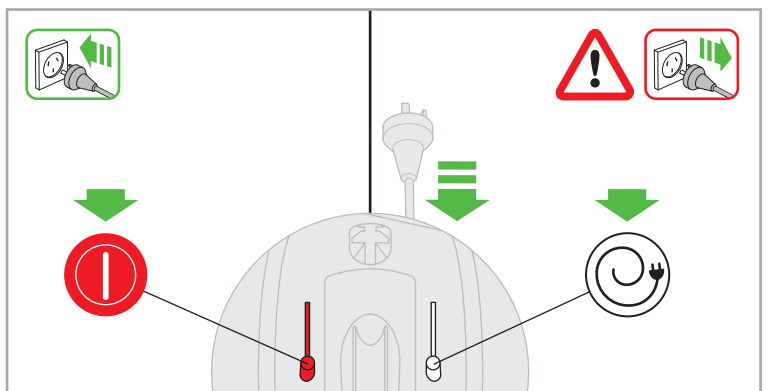

**REGISTER  
YOUR DYSON  
2 YEAR  
GUARANTEE  
TODAY**

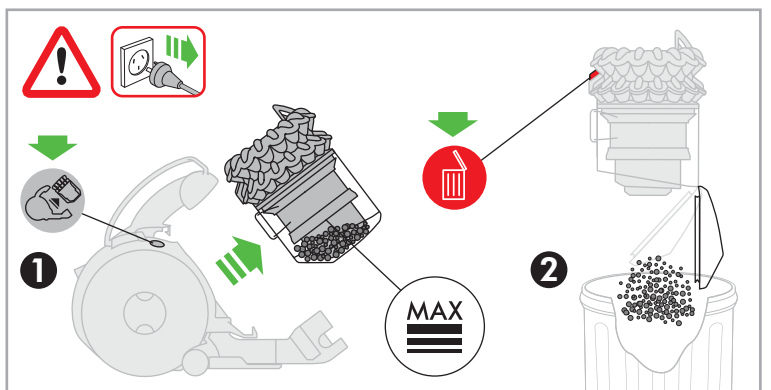

## DYSON CUSTOMER CARE

THANK YOU FOR CHOOSING TO BUY A DYSON APPLIANCE

Your Dyson appliance will be covered for parts and labour for 2 years from the date of purchase, as detailed in the terms of the Dyson guarantee on page 9 of this Dyson Operating Manual.

If you have a query about your Dyson appliance, call the Dyson Customer Care Helpline quoting your serial number and details of where and when you bought the appliance.

Your serial number can be found on your rating plate which is on the base of the appliance.

Most queries can be solved over the phone by one of our Dyson Customer Care Helpline staff (details below).

Visit our website to register your Dyson full parts and labour guarantee online.

AU: [www.dyson.com.au/register](http://www.dyson.com.au/register)

NZ: [www.dyson.co.nz/register](http://www.dyson.co.nz/register)

Note your serial number for future reference



This illustration is for example purposes only.

## 3 EASY WAYS TO REGISTER YOUR DYSON 2 YEAR GUARANTEE

### REGISTER ONLINE

Visit our website to register your Dyson full parts and labour guarantee online.

AU: [www.dyson.com.au/register](http://www.dyson.com.au/register)  
NZ: [www.dyson.co.nz/register](http://www.dyson.co.nz/register)

### REGISTER BY PHONE

Call our dedicated Helpline.

AU 1800 239 766  
NZ 0800 397 667

### REGISTER BY MAIL

Complete and return the form to Dyson in the envelope supplied

## IMPORTANT SAFETY INSTRUCTIONS

**BEFORE USING THIS APPLIANCE READ ALL INSTRUCTIONS AND CAUTIONARY MARKINGS IN THIS MANUAL AND ON THE APPLIANCE**

When using an electrical appliance, basic precautions should always be followed, including the following:

### WARNING

TO REDUCE THE RISK OF FIRE, ELECTRIC SHOCK, OR INJURY:

1. This Dyson appliance is not intended for use by young children or infirm persons with reduced physical, sensory or reasoning capabilities, or lack of experience and knowledge, unless they have been given supervision or instruction by a responsible person concerning use of the appliance to ensure that they can use it safely.
2. Do not allow to be used as a toy. Close attention is necessary when used by or near young children. Children should be supervised to ensure that they do not play with the appliance.
3. Use only as described in this Dyson Operating Manual. Do not carry out any maintenance other than shown in this Dyson Operating Manual, or advised by the Dyson Customer Care Helpline.
4. Suitable for dry locations only. Do not use outdoors or on wet surfaces.
5. Do not handle any part of the plug or appliance with wet hands.
6. Do not use with a damaged cable or plug. If the supply cable is damaged it must be replaced by Dyson, its service agent or similarly qualified person in order to avoid a hazard.
7. If the appliance is not working as it should, has received a sharp blow, has been dropped, damaged, left outdoors, or dropped into water, do not use and contact the Dyson Customer Care Helpline.
8. Contact the Dyson Customer Care Helpline when service or repair is required. Do not disassemble the appliance as incorrect reassembly may result in an electric shock or fire.
9. Do not stretch the cable or place the cable under strain. Keep the cable away from heated surfaces. Do not close a door on the cable, or pull the cable around sharp edges or corners. Arrange the cable away from traffic areas and where it will not be stepped on or tripped over.
10. Do not unplug by pulling on the cable. To unplug, grasp the plug, not the cable. The use of an extension cable is not recommended.
11. Do not use to pick up water.
12. Do not use to pick up flammable or combustible liquids, such as petrol, or use in areas where they or their vapours may be present.
13. Do not pick up anything that is burning or smoking, such as cigarettes, matches, or hot ashes.
14. Keep hair, loose clothing, fingers, and all parts of the body away from openings and moving parts. Do not point the hose, wand or tools at your eyes or ears or put them in your mouth.
15. Do not put any object into openings. Do not use with any opening blocked; keep free of dust, lint, hair, and anything that may reduce airflow.
16. Use only Dyson recommended accessories and replacement parts.
17. To avoid a tripping hazard rewind the cable when not in use.
18. Do not use without the clear bin and filters in place.
19. Do not leave the appliance when plugged in. Unplug when not in use and before servicing.
20. Do not pull or carry by the cable or use the cable as a handle.
21. Use extra care when cleaning on stairs. Do not work with the appliance above you on the stairs.
22. Turn off all controls before unplugging. Unplug before connecting any tool or accessory.
23. Always extend the cable to the red line but do not stretch or tug the cable.
24. Hold the plug when rewinding onto the cable reel. Do not allow the plug to whip when rewinding.

## READ AND SAVE THESE INSTRUCTIONS

THIS DYSON APPLIANCE IS INTENDED FOR HOUSEHOLD USE ONLY

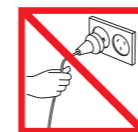

Do not pull on the cable.

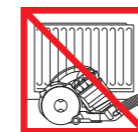

Do not store near heat sources.



Do not use near naked flames.



Do not run over the cable.



Do not pick up water or liquids.



Do not pick up burning objects.



Do not use above you on the stairs.



Do not put hands near the brush bar when the appliance is in use.



# IMPORTANT!

## WASH FILTERS

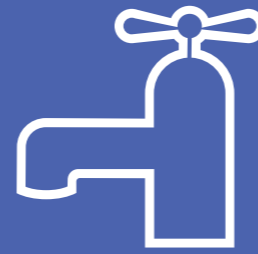

Wash filter with cold water regularly or as required.  
 Register for a filter wash reminder by email:  
 AU: [aucustomer@dyson.com](mailto:aucustomer@dyson.com)  
 NZ: [dyson@averyrobinson.co.nz](mailto:dyson@averyrobinson.co.nz)

**A**

Warning icons: exclamation mark, plug with arrow.

**B**

Warning icons: exclamation mark, plug with arrow.

Cleaning the clear bin

Warning icons: exclamation mark, plug with arrow.

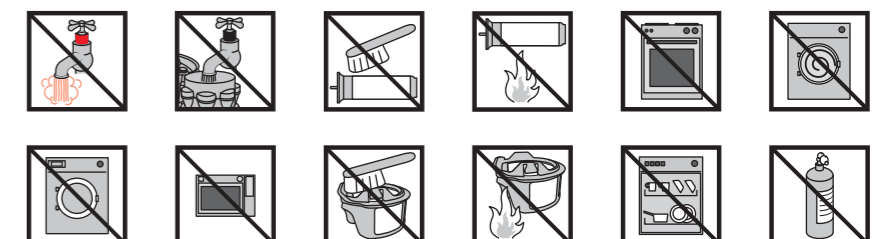

## USING YOUR DYSON APPLIANCE

PLEASE READ THE 'IMPORTANT SAFETY INSTRUCTIONS' IN THIS DYSON OPERATING MANUAL BEFORE PROCEEDING.

## CARRYING THE APPLIANCE

- Carry the appliance by the main handle on the body.
- Do not press the cyclone release button or shake the appliance when carrying or the cyclone could disengage, fall off and cause injury.

## OPERATION

- Always extend the cable fully to the red tape before use.
- Plug the appliance into the mains electricity supply.
- To switch 'ON' or 'OFF' press the red power button, located as shown.
- After use, unplug the appliance, retract the cable safely, and put the appliance away.
- Switch 'OFF' the appliance and unplug before:
  - Adjusting the setting.
  - Changing or using tools.
  - Removing the hose or airway inspection parts.
- To watch a short online video visit:  
[www.dyson.com.au/DC47gettingstarted](http://www.dyson.com.au/DC47gettingstarted)

## BRUSH BAR

- The brush bar will always default to 'ON' (spinning) each time you switch the appliance 'ON'.
- To switch the brush bar 'OFF' (e.g for delicate flooring and delicate rugs) press in the button on the cleaner head.
- To switch the brush bar 'ON', pull out the button on the cleaner head only enough so the brush bar engages.
- Brush bar control can be done only when the appliance is on.
- The brush bar will automatically stop if it becomes obstructed. See 'Brush bar – clearing obstructions' on pages 4 and 9.
- **Before vacuuming your flooring, rugs and carpets, check the manufacturer's recommended cleaning instructions.**
- **Some carpets may fuzz if a rotating brush bar is used when vacuuming. If this happens, we recommend vacuuming in 'hard floor' mode and consulting with the flooring manufacturer.**
- The brush bar on the appliance may damage some carpet types. If you are unsure, turn 'OFF' the brush bar.
- **This product has carbon fibre brushes. Take care if coming into contact with them, as they may cause minor skin irritation. Wash your hands after handling the brushes.**

## LOOKING AFTER YOUR DYSON APPLIANCE

- Do not carry out any maintenance or repair work other than that shown in this Dyson Operating Manual, or advised by the Dyson Customer Care Helpline.
- Only use parts recommended by Dyson. If you do not this could invalidate your Dyson guarantee.
- Store the appliance indoors. Do not use or store it below 0°C. Ensure the appliance is at room temperature before operating.
- Clean the appliance only with a dry cloth. Do not use any lubricants, cleaning agents, polishes or air fresheners on any part of the appliance.
- If used in a garage, always wipe the base plate and ball with a dry cloth after vacuuming to clean off any sand, dirt, or pebbles that could damage delicate floors.

## VACUUMING



### CAUTION:

- Do not use without the clear bin and filters in place.
- Fine dust such as plaster dust or flour should only be vacuumed in very small amounts.
- Do not use the appliance to pick up sharp hard objects, small toys, pins, paper clips, etc. They may damage the appliance.
- When vacuuming, certain carpets may generate small static charges in the clear bin or wand. These are harmless and are not associated with the mains electricity supply. To minimise any effect from this, do not put your hand or insert any object into the clear bin unless you have first emptied it and rinsed it out with cold water. See the 'Cleaning the clear bin' section on pages 6 and 8 of this Dyson Operating Manual.
- Do not work with the appliance above you on the stairs.
- Do not put the appliance on chairs, tables, etc.
- Before vacuuming highly polished floors, such as wood or lino, first check that the underside of the floor tool and its brushes are free from foreign objects that could cause marking.
- Do not push hard with the floor tool when vacuuming, as this may cause damage.
- Do not leave the cleaner head in one place on delicate floors during use.
- On waxed floors the movement of the cleaner head may create an uneven lustre. If this happens, wipe with a damp cloth, polish the area with wax, and wait for it to dry.

## EMPTYING THE CLEAR BIN

- Empty as soon as the dirt reaches the level of the MAX mark – do not overfill.
- Switch 'OFF' and unplug before emptying the clear bin.
- To remove the cyclone and clear bin unit, push the release button to the side of the carrying handle, as shown. The carrying handle will be released.
- Remove the cyclone and clear bin unit.
- To release the dirt, press the red bin release button.
- To minimise dust/allergen contact when emptying, encase the clear bin tightly in a plastic bag and empty.
- Remove the clear bin carefully.
- Seal the bag tightly, dispose as normal.
- Close the clear bin base so it clicks into place and is secure.

- Place the clear bin and cyclone unit into position on the front of the main body of the appliance. The recess in the rim of the base of the clear bin must fit onto the lug on the locator bracket.
- Push the carrying handle down so it clicks into place on the top of the clear bin and cyclone unit. Ensure it is secure.

## CLEANING THE CLEAR BIN

- Remove the cyclone and clear bin unit, and then open the bin base (see 'Emptying the clear bin' above).
- To separate the cyclone unit from the clear bin press the small silver button on the cyclone. Separate the cyclone from the clear bin.
- Clean the clear bin with cold water only.
- Do not use detergents, polishes or air fresheners to clean the clear bin.
- Do not put the clear bin in a dishwasher.
- Do not immerse the whole cyclone in water or pour water into the cyclones.
- Clean the cyclone shroud with a dry cloth or dry brush to remove lint and dust.
- Ensure the clear bin is completely dry before replacing.
- To replace, first close the clear bin base so it clicks into place and is secure.
- Fit the clear bin onto the cyclone. To secure it, first fit the slot on the front rim of the clear bin onto the lug on the front of the cyclone; then push the rear of the clear bin into place so the silver button engages and clicks into place.
- Fit the cyclone and clear bin unit onto the appliance (see 'Emptying the clear bin' above).

## WASHING YOUR FILTERS

- Your appliance has two lifetime washable filters, located as shown on page 6 of this Dyson Operating Manual.
- Check and wash the filters regularly or as required according to instructions to maintain performance.
- Switch 'OFF' and unplug before checking or removing the filters.
- The filters may require more frequent washing if vacuuming fine dust.
- Wash the filters with cold water only. Do not use detergents.
- Do not put the filters in a dishwasher, washing machine, tumble dryer, oven, microwave or near a naked flame.

### Filter A

- To access filter A, first remove the clear bin and cyclone unit (see 'Emptying the clear bin' above). Lift out the filter.
- Wash the filter with cold water only. Hold under a tap and run water through the open end for 10 seconds. Turn upside down and tap out.
- Squeeze filter to remove any excess water.
- Run water over the outside of the filter for 15 seconds.
- Squeeze filter to remove any excess water.
- Stand the filter on its wide, open end to dry completely. Leave to dry completely for 24 hours.
- Replace the filter into the cyclone. Fit the cyclone and clear bin unit onto the appliance (see 'Emptying the clear bin' above).

### Filter B

- To access filter B, turn the central locking dial on the outer cover of the ball anti-clockwise until the cover is released. Lift off the cover.
- To lift out the filter, place your fingers under the two raised tabs. Lift out the filter. Use a constant, firm pressure.
- Filter B should be rinsed in cold water only, inside and outside, and tapped out until the water runs clean, then tapped out again to ensure all excess water is removed. (Tap on the plastic rim, not the filter material.) Leave to dry completely for 24 hours.
- It is normal for the filter in the ball to turn grey in colour.
- To refit filter B:
  - Slide the filter back into the ball.
  - Push the filter in until the tabs engage – you will hear a click when they do.
- Refit the outer cover of the ball.
- When refitting the outer cover of the ball, keep turning the central locking dial clockwise. When it starts to click it is locked.

**IMPORTANT:** After washing please leave for at least 24 hours to dry completely before refitting.

- To watch a short online video visit:  
[www.dyson.com.au/DC47filterwash](http://www.dyson.com.au/DC47filterwash)

## LOOKING FOR BLOCKAGES

- Switch 'OFF' and unplug before looking for blockages. Do not operate the wand release catch. Failure to do so could result in personal injury.
- Beware of sharp objects when checking for blockages.
- Refit all parts securely before using.
- To check for blockages in airway on the main body of the appliance, first remove the cyclone and clear bin unit by pushing the release button to the side of the carrying handle, as shown.
- To remove the transparent inlet section, release the latch on the top. Remove the inlet section.
- Inspect for blockages.
- Replace the inlet section. Ensure the latch clicks into place and engages.
- Clearing blockages is not covered by your Dyson guarantee.

## CLEARING BLOCKAGES – THERMAL CUT-OUT

- This appliance is fitted with an automatically resetting thermal cut-out. If any part becomes blocked the appliance may overheat and automatically cut-out.
- Switch 'OFF' and unplug. Leave to cool down for 1-2 hours before checking filter or for blockages.
- Clear any blockage before restarting.
- Clearing blockages is not covered by your Dyson guarantee.
- NOTE: Large items may block the tools or wand inlet. If this happens, do not operate the wand release catch. Switch 'OFF' and unplug. Failure to do so could result in personal injury"

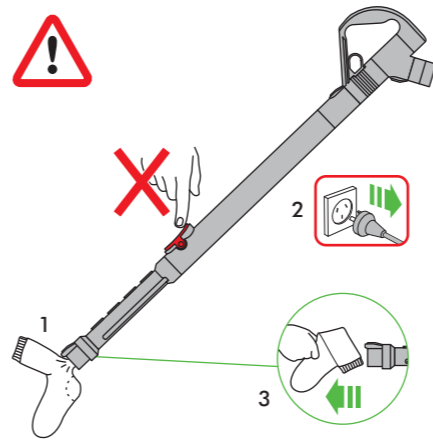

## BRUSH BAR – CLEARING OBSTRUCTIONS

- If your brush bar is obstructed, it may shut 'OFF'. If this happens you will need to remove the brush bar as shown.
- Switch 'OFF' and unplug before proceeding. Failure to do so could result in personal injury.
- Remove the brush bar by using a coin to loosen the fastener marked with a padlock until it clicks, as shown on page 4.
- Beware of sharp objects when clearing obstructions.
- Replace the brush bar and secure it by tightening the fastener until it clicks. Ensure it is fixed firmly before operating.
- **This product has carbon fibre brushes. Take care if coming into contact with them, as they may cause minor skin irritation. Wash your hands after handling the brushes.**
- Clearing brush bar obstructions is not covered by your Dyson guarantee.

## BRUSH BAR – TROUBLESHOOTING

If the brush bar has stopped spinning, follow the instructions above on clearing obstructions. Alternatively, contact the Dyson Customer Care Helpline or visit the Dyson website.

## AUSTRALIAN CONSUMER LAW

The details of the Dyson guarantee are set out below. In addition to your rights under the Dyson guarantee, we also provide the following statement as required by the Australian Consumer Law: In Australia, your Dyson appliance comes with statutory guarantees that cannot be excluded under the Australian Consumer Law. You are entitled to a replacement or refund for a major failure and for compensation for any other reasonably foreseeable loss or damage. You are also entitled to have your Dyson appliance repaired or replaced if it fails to be of acceptable quality and the failure does not amount to a major failure.

## DYSON 2 YEAR GUARANTEE

### TERMS AND CONDITIONS OF YOUR DYSON 2 YEAR GUARANTEE.

- The Dyson guarantee becomes effective from the date of purchase.
- All work will be carried out by Dyson Appliances (Aust) Pty Ltd., Avery Robinson Ltd. (NZ) and their authorised agents.
- Any parts replaced will become the property of Dyson Appliances (Aust) Pty Ltd. or Avery Robinson Ltd. (NZ).
- The Dyson guarantee provides benefits which are additional to and do not affect your statutory rights and remedies as a consumer.
- You must provide proof of (both the original and any subsequent) delivery/purchase before any work can be carried out on your Dyson appliance. Without this proof, any work carried out pursuant to the Dyson guarantee and any associated delivery charges (both to and from us) will be at your cost, subject to your statutory rights and remedies as a consumer. Please keep your receipt or delivery note.

## WHAT IS COVERED

Your Dyson guarantee covers:

- The repair or replacement of your Dyson appliance if your Dyson appliance is found to be defective due to faulty materials, workmanship or function within 2 years of purchase or delivery (if any part is no longer available or out of manufacture, Dyson will replace it with a functional replacement part).
- Use of the appliance in the country of purchase.

## WHAT IS NOT COVERED

Under your Dyson guarantee, Dyson shall not be liable for costs of repair or replacement of a product incurred as a result of:

- Accidental damage, faults caused by negligent use or care, neglect, careless operation or handling of the Dyson appliance which is not in accordance with this Dyson Operating Manual.
- Use of the Dyson appliance for anything other than normal domestic purposes in the country of purchase.
- Use of parts not assembled or installed in accordance with the instructions of Dyson.
- Use of parts and accessories other than those produced or recommended by Dyson.
- Repairs or alterations carried out by parties other than Dyson or its authorised agents.
- Damage from external sources such as transit, weather, electrical outages or power surges.
- Failures caused by circumstances outside Dyson's control.
- Blockages – please refer to pages 4,5,8 and 9 in this Dyson Operating Manual for details on how to unblock your Dyson appliance.
- Normal wear and tear (e.g. fuse, brush bar, etc).
- Industrial use of the Dyson appliance such as vacuuming gyprock dust or builders' dust may void your Dyson guarantee.

If your Dyson guarantee does not apply, you may have statutory rights and remedies available to you as a consumer.

If you are in any doubt as to what is covered by your Dyson guarantee, please call the Dyson Customer Care Helpline (see details on page 10).

## REGISTERING YOUR DYSON GUARANTEE

To help us ensure you receive prompt and efficient service, please register as a Dyson appliance owner. There are three ways to do this:

- Online.  
AU: [www.dyson.com.au/register](http://www.dyson.com.au/register)  
NZ: [www.dyson.co.nz/register](http://www.dyson.co.nz/register)
- By calling the Dyson Customer Care Helpline.
- By completing and returning the enclosed form to us by mail. This will confirm ownership of your Dyson appliance in the event of an insurance loss and enable us to contact you if necessary.

## DYSON CUSTOMER CARE

- If you have a query about your Dyson appliance, call the Dyson Customer Care Helpline quoting your serial number and details of where and when you bought the appliance or contact us via the website.
- Most queries can be solved over the phone by one of our Dyson Customer Care Helpline staff.
- If your Dyson appliance needs a service, call the Dyson Customer Care Helpline so we can discuss the available options.
- Your serial number can be found on your rating plate which is on the base of the appliance.
- To enable us to carry out work on your appliance, please contact the Dyson Customer Care Helpline to obtain a reply paid delivery address in your state (available in Australia only).

If your Dyson appliance is under Dyson guarantee and the repair or replacement is covered, it will be repaired or replaced at no cost. If the repair or replacement is found not to be covered under the Dyson guarantee, the repair or replacement of the Dyson appliance and any associated delivery charges (both to and from us) will be at your cost, subject to your statutory rights and remedies as a consumer.

## ABOUT YOUR PRIVACY

Dyson may use this information for future marketing and research purposes (including sending commercial electronic messages) and may disclose it to third parties for the purposes of providing the services you have requested or to our business partners or professional advisers. If you wish to access your personal information or see our full privacy policy, please contact us at: [aucustomercare@dyson.com](mailto:aucustomercare@dyson.com)

## DISPOSAL INFORMATION

Dyson products are made from high grade recyclable materials. Please dispose of this product responsibly and recycle where possible.

When your Dyson appliance reaches the end of its life, we are responsible for its safe disposal. You can send your old Dyson appliance back to us (at our cost) and we will organise for it to be recycled.\*

\*Please note that not all parts are recyclable. Recycling of parts is subject to the capabilities of 3rd party suppliers. Available in Australia only.

Simply:

1. Box up your old Dyson appliance.
2. Take the package to your local post office and send to the address below:

Dyson We Recycle  
Reply Paid 83215  
Dyson Service Centre  
8-10 Mangrove Lane  
Taren Point, NSW 2229

## PRODUCT INFORMATION

Please note: Small details may vary from those shown.

# IMPORTANT!

## WASH FILTERS



Wash filter with cold water regularly or as required.  
Register for a filter wash reminder by email:  
AU: [aucustomer@dyson.com](mailto:aucustomer@dyson.com)  
NZ: [dyson@averyrobinson.co.nz](mailto:dyson@averyrobinson.co.nz)

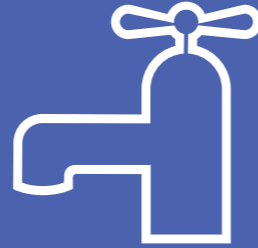

### Dyson Customer Care

Your Dyson appliance will be covered for parts and labour for 2 years from the date of purchase, subject to the terms and the Dyson guarantee.

If you have a query about your Dyson appliance, call the Dyson Customer Care Helpline quoting your serial number and details of where and when you bought the appliance.

Most queries can be solved over the phone by one of our Dyson Customer Care Helpline staff.

#### DYSON CONTACT DETAILS

##### Australia

Website: [www.dyson.com.au](http://www.dyson.com.au)

Email: [aucustomer@dyson.com](mailto:aucustomer@dyson.com)

Dyson Customer Care: 1800 239 766 (Mon-Fri 8:00am to 6:00pm EST, Sat-Sun 8:30am to 4:00pm EST).

Address: Dyson Appliances (Aust) Pty Ltd.,  
PO Box 2835, Taren Point, NSW 2229 Australia.

##### New Zealand

Website: [www.dyson.co.nz](http://www.dyson.co.nz)

Email: [dyson@averyrobinson.co.nz](mailto:dyson@averyrobinson.co.nz)

Dyson Customer Care: 0800 397 667 (Mon-Fri 8:30am to 5:00pm).

Address: Avery Robinson Ltd., Unit F, 151D Marua Road, Ellerslie, Auckland, 1051 New Zealand.

# dyson GUARANTEE FORM

2 year guarantee – plus option to extend to 5 years.

## Section 1: Dyson 2 year guarantee

Please complete Section 1 to register as a Dyson appliance owner, and return it in the envelope provided. Alternatively, register online.

Serial number		
Date of purchase		Country of purchase
<input type="text"/> / <input type="text"/> / <input type="text"/>	AU <input type="checkbox"/> NZ <input type="checkbox"/>	
Store of purchase		
<input type="text"/>		
Did you purchase an extended warranty from the retailer?		
Yes	<input type="checkbox"/>	No <input type="checkbox"/>
If yes, for what additional period?		
1 year	<input type="checkbox"/>	2 years <input type="checkbox"/> 3 years <input type="checkbox"/>
Title	First name	Surname
<input type="text"/>	<input type="text"/>	<input type="text"/>
Address		
<input type="text"/>		
<input type="text"/>		
<input type="text"/>		
Postcode		<input type="text"/>
email	Contact number	
<input type="text"/>	<input type="text"/>	
<b>Privacy Act</b>		
Dyson may use this information for future marketing and research purposes (including sending commercial electronic messages) and may disclose it to third parties for the purposes of providing the services you have requested or to our business partners or professional advisers. If you wish to access your personal information or see our full privacy policy, please contact us at <a href="mailto:aucustomer@dyson.com">aucustomer@dyson.com</a>		
If you wish to receive marketing information by these methods from Dyson please tick this box. <input type="checkbox"/>		

**REGISTER ONLINE**  
Visit our website to register your Dyson full parts and labour guarantee online.

**AU: [www.dyson.com.au/register](http://www.dyson.com.au/register)**  
**NZ: [www.dyson.co.nz/register](http://www.dyson.co.nz/register)**

**REGISTER BY PHONE**  
Call our dedicated Helpline.

**AU 1800 239 766**  
**NZ 0800 397 667**

**REGISTER BY MAIL**  
Complete and return the form to Dyson in the envelope supplied.

## Section 2: Dyson 2+3 year guarantee

Increase your Dyson 2 year guarantee cover to 5 years when you purchase an extended guarantee from Dyson (Australia only). This option is just AU\$89.00. Dyson is committed to providing the best Aftersales Service, which is why we offer the option to extend your Dyson 2 year guarantee to 5 years. The terms of the Dyson 2 year guarantee on page 9 of this Dyson Operating Manual will apply to the Dyson extended guarantee. The Dyson extended guarantee is underwritten by Dyson Appliances (Aust) Pty Ltd. To purchase, just complete the fields below. Send both sections to us, together with your cheque/money order or credit card details, within 2 years of your vacuum cleaner purchase. Offer to purchase the Dyson extended guarantee is only available within 2 years of customers purchasing their vacuum cleaner. Offer not available to customers who have purchased an extended warranty from a retailer. The Dyson extended guarantee provides benefits which are additional to, and do not affect, your statutory rights and remedies as a consumer. If you decide not to extend your Dyson 2 year guarantee, you may have statutory rights and remedies available to you as a consumer.

Cheque/money order made payable to: Dyson Appliances.

Credit card  Mastercard   Visa

Card Number  /  /  /  Expiry Date M/M   Y/Y

**Declaration**

I hereby apply for the Dyson vacuum cleaner extended guarantee in accordance with the terms and conditions of your plan. I confirm the vacuum cleaner is in good working order and used for domestic purposes only and declare that the details on this proposal are true and complete to the best of my knowledge and belief.

Signature  Date  /  /

WARNING Any false statement may render this plan invalid

