

10

ALL-WAVE RADIO

NOVEMBER
1935

Vol. 1



No. 2

15
CENTS
U.S.A.

20 cents
in Canada

METAL



or

GLASS



REVIEW OF 1936 ALL-WAVE RECEIVERS

Reinartz Rotary Beam Aerial
Improved S. W. Station List
New "Long Lines" Oscillator

Professional All-Wave Receiver
Engineers Discuss Broadcasting
The Silver Masterpiece IV

BOUCK - BEAT NOTE - LESTER - GRANGER - SILVER - TUMMONDS - HINDS

ULTRA SHORT AND SHORT WAVE • BROADCAST AND LONG WAVE

From the Publisher to you

PUBLISHED BY
MANSON PUBLICATIONS CORP.

TELEPHONE
STUYVESANT 9-0256

ALL WAVE RADIO
200 FIFTH AVENUE
NEW YORK CITY

NEW YORK
Oct 22
1935

Dear Reader:

Thank you for your wonderful response to our first issue of ALL WAVE RADIO. In hundreds of letters you have told us in glowing terms that our venture is already assured of success.

I want to let you know that our organization does not intend to rest on its laurels, but is already actively engaged in securing and preparing for you editorial material that in every sense of the word will be acknowledged the "tops".

Our aim is to make ALL WAVE RADIO the best magazine in the field. Letters of praise are greatly appreciated but it is your suggestions and criticism that will materially assist us in reaching this goal. So let's have them.

In spite of the fact that our circulation department made every effort to guarantee a complete dis-tribution throughout the United States. To avoid the risk of missing a single issue of this magazine, let me suggest that you mail us your subscription promptly. Of course, this is a saving to you, as the price is \$1.50 per year.

Again my thanks to you for your overwhelming reception of ALL WAVE RADIO.

Cordially,

Clarence Emerson
Clarence Emerson
Publisher

CWE:S

A NATIONAL MONTHLY MAGAZINE
ULTRA SHORT AND SHORT WAVE • BROADCAST AND LONG WAVE

I will send you a Lesson Free



J. E. SMITH, President, National Radio Institute, Washington, D. C.—the man who has directed the training of more men for the Radio industry than any other man in America.

to show how easy it is to learn at home in spare time to fill a

Good Radio Job

Clip and mail the coupon, I'll send you a FREE lesson. I'll show you that Radio is fascinating; that I give you practical money-making information, easy to learn, easy to put into use. See for yourself why many men with less than a grammar school education and no Radio experience are now making good money as Radio Experts. Get the facts about Radio's spare time and full time job opportunities. Mail the coupon now.

Many Radio Experts make \$30, \$50, \$75 a week. Get ready for jobs like these

Broadcasting stations employ engineers, operators, managers, and men for other jobs that pay up to \$5,000 a year. Radio factories employ testers, inspectors, foremen, engineers, servicemen, salesmen, buyers, and pay up to \$6,000 a year. Radio dealers and jobbers employ servicemen, salesmen, buyers, managers, and pay up to \$75 a week. There are many opportunities to have a spare time or full time Radio service business of your own. Radio is picking up. It's a big business—big enough to absorb many more well trained men—and it's growing bigger all the time. Get ready for Radio. Be a Radio Expert. I'll train you at home in spare time.

Many make \$5, \$10, \$15 a week Extra in Spare Time almost at once

Nearly every neighborhood needs a good spare time serviceman. Find out how I help you cash in—how I start sending you Extra Money Job Sheets the day you enroll, for doing Radio repair jobs common in most every neighborhood. How, when you get underway, I send you much more information for servicing sets and for doing other spare time jobs for extra money. My Training is famous as "The Course that Pays for Itself." Many make \$200 to \$1,000 while learning.

Short Wave, Loud Speaker Systems Television, Auto Radio, etc., included

New Radio developments are continually making new opportunities. Loud speaker systems, police, auto and aviation Radio, are recent new uses that have been found for it. Television promises many good jobs soon. Television is leaving the laboratory in an impressive way. One million dollars is being spent on two stations. Television receiving sets are being designed and built. New opportunities—many of them—are right ahead. Get full information about how I train you at home in spare time to be a Radio Expert. My 50-50 method of training—half with printed and well illustrated lessons, half with Radio equipment I furnish as part of my training—gives you broad practical experience—makes learning at home interesting, fascinating, practical.

You must be Satisfied

I make an agreement with you in writing—if you are not entirely satisfied when you finish my Course, with the lesson and instruction service I have given you, every penny you have paid me for tuition will be refunded.

Get a Sample Lesson and my book on Radio's Opportunities

Mail coupon now. I'll send my book "Rich Rewards in Radio" and a FREE lesson at once. Find out about Radio's spare time and full time opportunities; read what others who have taken my Course are doing and making. Read the sample lesson, decide for yourself whether my training is clear, interesting, practical. This offer is open to any ambitious fellow over 16 years old. There is no obligation. Act at once. Mail coupon in an envelope or paste on a 1c postcard.

J. E. SMITH, President
National Radio Institute, Dept. 5MS1
Washington, D. C.



SET SERVICING has paid many N.R.I. men \$5, \$10, \$15 a week extra for their spare time. Full time men make as much as \$30, \$50, \$75 a week.

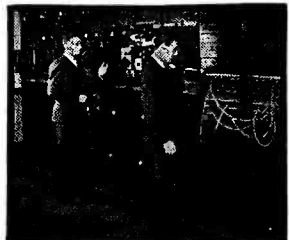

BROADCASTING STATIONS employ many technically trained men for interesting, fascinating jobs paying up to \$100 a week.

GET MY FREE LESSON on Radio Servicing Tips

I'll prove that my training is practical, money-making information, that it is easy to understand—that it is just what you need to master Radio. My sample lesson text, "Radio Receiving Troubles—the Cause and Remedy" covers a long list of Radio receiver troubles in A. C., D. C., battery, universal, auto, T. R. F., super-heterodyne, all-wave, and other types of sets. And a cross reference system gives you the probable cause and a quick way to locate and remedy these set troubles. A special section is devoted to receiver check-up, alignment, balancing, neutralizing and testing. Get this lesson. Free. No obligation. Just mail Coupon.

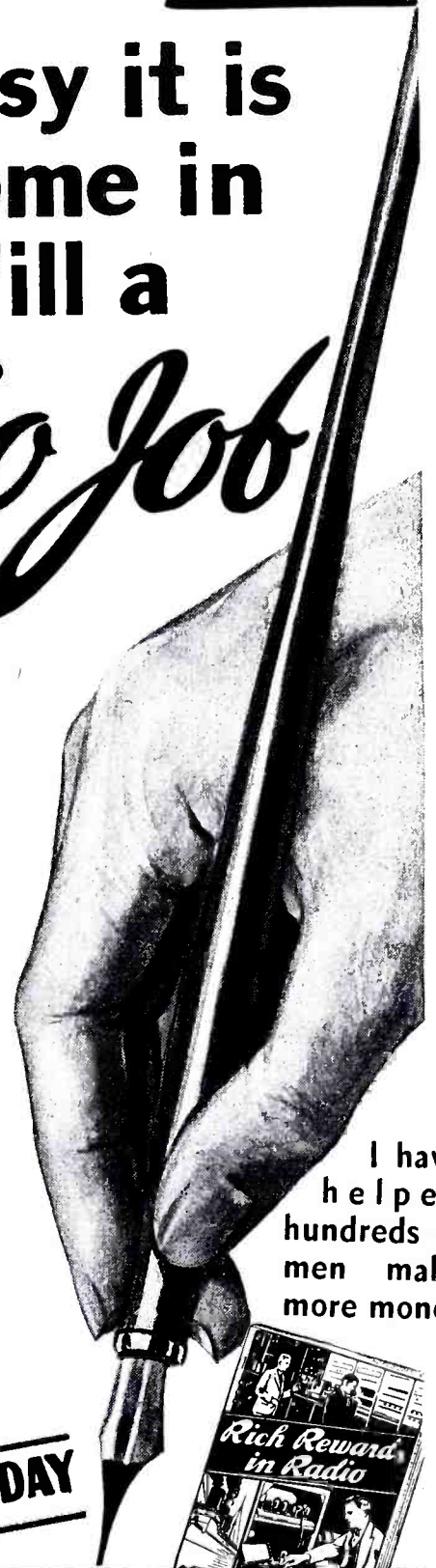

I have helped hundreds of men make more money

MAIL THIS TODAY

Good for **FREE SAMPLE LESSON** and **BOOK on RADIO'S OPPORTUNITIES**

J. E. SMITH, President
National Radio Institute, Dept. 5MS1
Washington, D. C.

I want to take advantage of your offer. Without obligating me, send me your Free Sample Lesson and your book, "Rich Rewards in Radio." (Please print plainly.)

NAME..... AGE.....
ADDRESS.....
CITY..... STATE.....14X1

The Tested Way to BETTER PAY



FROM ALL THE WORLD

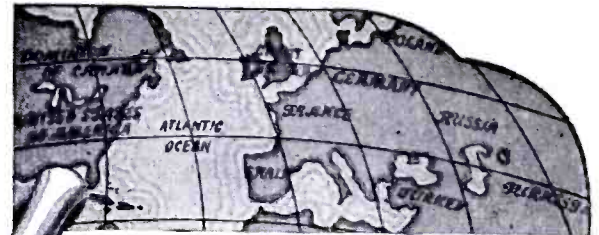
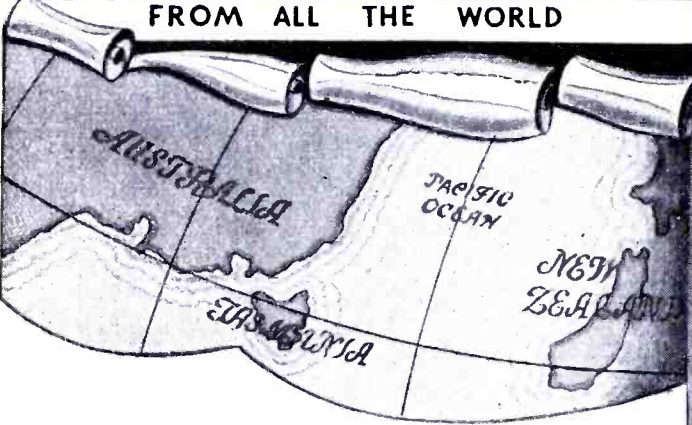

INTO YOUR OWN HOME

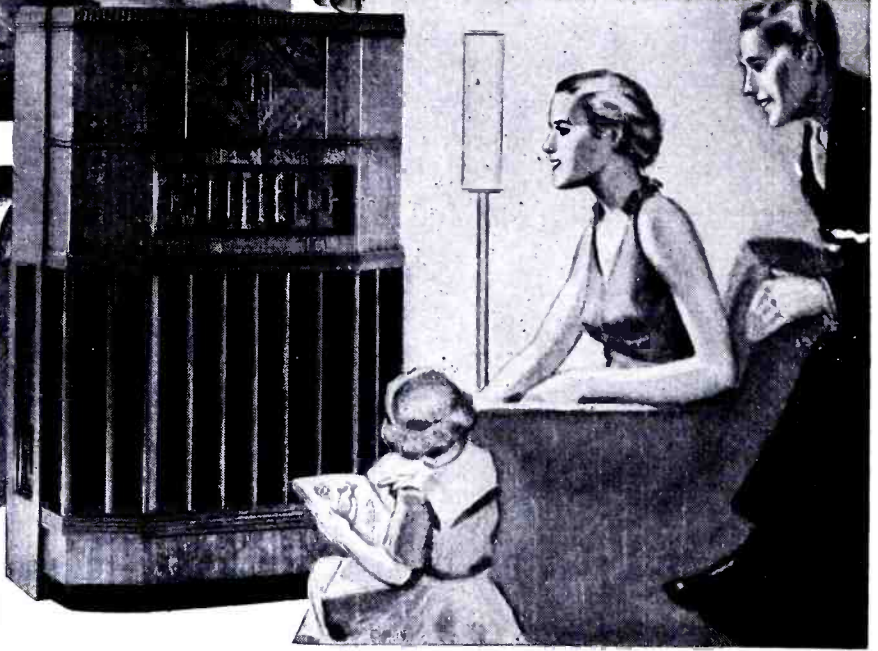

Only the **SCOTT**
Full Range Hi-Fidelity
ALL-WAVE

BRINGS YOU THE FULL BEAUTY OF THE AUSTRALIAN KOOKABURRA'S STARTLING LAUGH

Across the nightfall sky a rush of wings—a sudden laugh, high-pitched, weird, thrilling—laugh of the powerful-throated Kookaburra! Challenging voice of Australia's national bird—regularly from VK2ME Sydney!

In the same breath-taking instant—10,000 miles through the night—you hear this exciting cry with all its inspiring realism—as *only* the magnificent new SCOTT brings it to you!

Australia to Argentina—England to Ecuador—Portugal to Panama—France—Germany—Italy—from *more* foreign stations than can be heard on any other radio—the new SCOTT brings you a tremendous pageant of world programs with a *tone truth*, a *volume strength*, a *diamond clarity* not even approached by any other radio on earth!

50% CLEARER FOREIGN RECEPTION

Highest Useable Sensitivity of any radio at any price—a fact we can prove in an actual comparative test! Six times the undistorted loudspeaker range of the average radio.

The *only* receiver that captures all the glorious beauty of high-fidelity programs for you! Other high-fidelity radios miss half the audible tone range. The *only* receiver which directs the straight-travelling high tones to your ear level *no matter where you sit* in the room.

THE RADIO THE CELEBRITIES OWN

Custombuilt. Fully two years ahead of any receiver sold today. Every SCOTT carries an unqualified guarantee to outperform any radio in the world. Thousands of SCOTTS back this distinguished guar-

antee with world-record-breaking success—finest testimony to superiority that any manufacturer can offer! This is the internationally famous receiver owned by Toscanini, Guy Lombardo, Al Jolson, Eddie Cantor, Rudy Vallee, Walter Winchell, and hundreds of other celebrities.

FIVE YEAR GUARANTEE

Hear the new SCOTT! You will never be satisfied to own any other radio. Sold direct from the laboratories on 30 day home trial anywhere in U.S.A.—for no more than you would pay for an ordinary radio.

Decide right now, without delay, to send coupon! Send it **TODAY**—we will gladly mail you "94 PROOFS" of SCOTT superiority, and the most thrilling story of unequalled distance performance that has ever been recorded.

ENJOY WORLD RECEPTION



WITH THE RADIO THAT HOLDS THE MOST VERIFIED DISTANCE RECORDS

BULLET-DIRECT SELECTIVITY—piercing the most powerful adjacent wave length stations, bringing you world programs you have never heard before. Continuously variable, 2 to 16 K.C.

HIGHER USEABLE SENSITIVITY—less outside noise than any receiver.

SIX TIMES AVERAGE POWER—for VASTER distances. 35 watts strictly Class "A." (Be sure to check this when considering your new radio. Only *high* Class "A" power brings undistorted programs.)

PERFECTED AUTOMATIC VOLUME CONTROL—keeps world programs at even volume.

SHORT WAVE STATION LOCATOR—tells you instantly when you tune in distant station.

DIFFUSION PANELS—directs all musical frequencies equally throughout the room.

TONE DISTRIBUTION—two special additional speakers distribute the glorious straight-travelling higher tones evenly to all listeners.

FULL RANGE HI-FIDELITY—twice the tonal range of any high-fidelity receiver. 25 to 16,000 cycles.

MORE NEW FEATURES OF IMPORTANCE than any receiver, including True Bass Control, Micromatic Dial Calibration, All Tuning Bands, Shadow Tuning, New Highest Efficiency Tubes.

SEND THIS COUPON TODAY—DETAILS FREE

E. H. Scott Radio Laboratories, Inc.
4476 Ravenswood Ave., Dept. 31T5
Chicago, Ill.

Send me complete details on new SCOTT Full Range Hi-Fidelity Allwave, "94 PROOFS" of its superior tone, DX performance, and particulars of the 30 day home trial anywhere in U.S.A.

Name.....

Street.....

City.....State.....

YOU OWE THIS TO YOURSELF

ALL-WAVE RADIO

VOL. 1

NO. 2

CONTENTS FOR NOVEMBER, 1935

W2JBU

Cover Illustration

The Big Question—Which Is It To Be? See Page 61

(Photos courtesy Hygrade-Sylvania Corp.)

Features

BROADCASTING MOVES AHEAD	55	
REVIEW OF 1936 ALL-WAVE RECEIVERS	By G. S. Granger	56
THE LAFAYETTE PROFESSIONAL NINE	By Frank Lester	65
AMATEUR STATION W2CLA	By S. P. McMinn	70
THE MASTERPIECE IV	By McMurdo Silver	75
REINARTZ S. W. ROTARY BEAM AERIAL	By H. A. Tummonds	72
A DOCTOR—AN AMATEUR	By Floyd Miers	78
A LONG-LINES OSCILLATOR	By Ed. Ruth	80
DESIGN OF TRANSFORMERS FOR AMATEURS	81	

Departments

DIAL LIGHT	53	
GLOBE GIRDLING	By J. B. L. Hinds	62
ROSES AND RAZZBERRIES	By Beat Note	69
CHANNEL ECHOES	By Zeh Bouck	85
THE FOOTLOOSE REPORTER—"Spy Chaser"	By G. C. B. R.	82
RADIO PROVING POST: The Bosch Model 575	83	
BACKWASH—The Readers' Forum	84	
IN WRITING FOR VERIES	86	
SHORT-WAVE STATION LIST	88	

Published Monthly by the

CLARENCE W. EMERSON
President

MANSON PUBLICATION CORP.

EDWIN W. LEDERMAN
Treasurer

Yearly subscription rate:
\$1.50 in the United States;
\$2.00 in Canada; \$4.00 in
foreign countries.

200 FIFTH AVENUE
NEW YORK, N. Y.

Application for entry as
second class matter at the
Post Office at New York,
N. Y., under the act of
March 3, 1879, pending.

NOVEMBER, 1935

51

SILVER MASTERPIECE IV

Custom Built

ALL-WAVE
WORLD-WIDE
RECEIVER



**25 NEW
ADVANCED
FEATURES!**

- 19 Tubes, providing twenty-three distinct tube functions.
- Perfected Circuit.
- Unmatched Flexibility of Control.
- Unequaled freedom from noise.
- Selectivity, extreme and variable.
- Unmatched Tone Quality.
- Double High Fidelity.
- 35 Watt Undistorted Output.
- Amplified Automatic Volume Control.
- Airplane Dial with 5 accurately calibrated tuning scales.
- Band Spread Tuning.
- 2 Tuned R.F. Stages on all 5 bands.
- Air Dielectric Trimmer Condensers Throughout.
- No-loss R.F. Inductances.
- All R.F. and I.F. circuits Air Tuned.
- Doubly Amplified Tuning Meter.
- Calibrated Sensitivity Control.
- Complete Circuit Isolation.
- Completely Shielded.
- Public Address and Phonograph Operation.
- No Microphonic Howling.
- Two Matched Speakers.
- Every Part Individually Tested.
- Complete Professional Flexibility.
- One Year Free Service.

AND IN ADDITION . . .
MASTERPIECE IV brings you those important basic features which won for its three predecessors the acclaim of critical users the world over.

MCMURDO SILVER CORP.

Division of G. P. H. Inc.

3370 N. Paulina Street

Chicago, U. S. A.

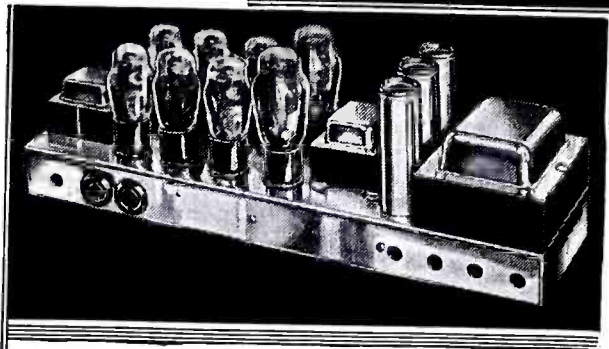

FOR outstanding performance under any and all conditions, the record of the new MASTERPIECE IV has provided the radio sensation of the year. If you haven't tried it, you are missing the greatest thrill you have ever experienced in perfected all-wave reception.

Whether you want to bring in weak short wave stations half way 'round the world, that other receivers will not touch . . .

Whether you really want long-distance broadcast reception, free from set noise, fading, interference . . . great power without distortion . . .

Whether you want tone quality such as you have never heard before . . . lifelike fidelity that makes you feel the actual, living presence of programs right in you own home . . .

Whatever you may ask of any radio receiver, the MASTERPIECE IV can give you faithfully, consistently, day in and day out.

But confident as we are that this champion receiver will be a revelation to you, we do not ask you to take our word for it.

*. . . the finest Radio
of all time!*

We do not even ask you to take the word of discriminating users — engineers, musicians, champion DX tuners, broadcast station executives, radio editors, governments, experienced listeners — who make up the ever-increasing army of enthusiastic MASTERPIECE owners.

What we suggest is that you let MASTERPIECE IV itself prove its superiority in comparison with any all-wave receiver, at any price, with you as the sole judge.

Try it for 10 days in your own home or laboratory, under your own reception conditions. If it fails to meet every test, return it undamaged and your money will be promptly and cheerfully refunded, less only transportation charges.

Mail the coupon Today for a Free copy of the 32-page "Blue Book of Radio," giving complete analytical description and full details of our 10-DAY TRIAL Offer and 5-YEAR GUARANTEE.

---MAIL COUPON FOR FREE BOOK---

McMURDO SILVER CORPORATION
3370 N. Paulina Street, Chicago, U. S. A.
Send Free "Blue Book" giving complete specifications of Silver MASTERPIECE IV, with details of 10-DAY TRIAL Offer.

Name

Address

City State

10-A

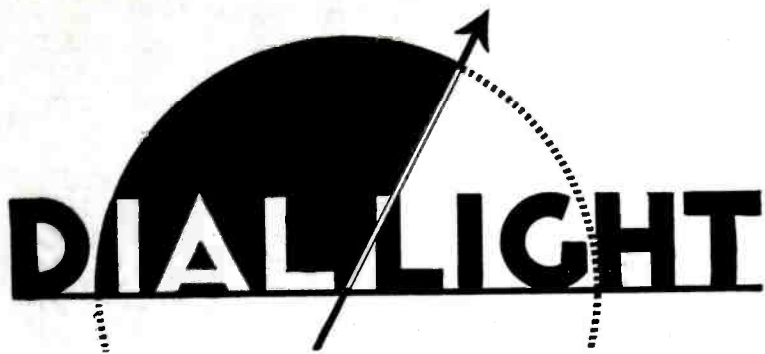

DIAL LIGHT

THE INSTITUTION OF a new publication and the shaping of its policies is much like the art of sculpture—the image is made in the rough, is added to bit by bit, is altered here and there, and finally is a finished work. If the shaper is fortunate, then the result is an achievement in the expression of an ideal.

Like the sculptor, we have caught ourselves repeatedly “standing off” to obtain the perspective of our work . . . have caught ourselves returning to the image to add a bit here or scoop off a bit there, but always with our ears open to the commendations and criticisms from those who stand behind us . . . you, the reader.

And we have learned a great deal in the short time we have been at the task. We have learned, for one thing, that the general policy of the magazine is highly approved; that there are more radio fans than we realized who have felt themselves dealt with unfairly and are seeking only some publication in which they may have implicit faith. In response to this expression, we can only repeat: that so long as this magazine exists, each member of the staff will be mindful of the basic policy.

In the newspaper office, they ask: “Is It News?” We have created a motto similar in character, as a continuous reminder. It is: “Put Yourself In The Reader’s Shoes.”



CRITICISMS HAVE BEEN received, for which we are thankful. The manner in which the station lists were presented was not generally approved. Consequently, they have been completely done over after the manner in which most readers would prefer to have them.

Mr. Martin’s article was so well received that we have commenced the preparation of a similar manuscript dealing with the design and circuits of the manufactured receiver. This will appear in the December issue, and we are sure you will find it enlightening.

We have been asked for the low-down on metal tubes. They are discussed by Mr. Granger in this issue. It is a bit too early to put things down in black and white, but what Mr. Granger has to say about the metal tubes may be taken to imply that, so far, we are quite satisfied with

them. We will have more to say about them after we know more about their life span.



WE HAVE LEARNED that there are innumerable readers of ALL-WAVE RADIO who, if not active in amateur radio, find it of such unending interest that they wish to have some space devoted to it each month.

Judging from letters received, many all-wave listeners use the amateur ’phone bands as their “stamping grounds,” and would like to know more of the amateurs themselves and the stations they operate. Other listeners seem anxious to enter the field, but find it exceedingly difficult to follow the more technical articles dealing with amateur operation and the construction of equipment. Many readers active in the amateur field also express the wish that “Ham” radio be given consideration.

So, we are trying it as an experiment. Read the “Ham Radio” articles in this issue and let us know if you like them.

We are toying with the idea of preparing a complete series of articles on the Story of Amateur Radio—how it started, the ideals supporting it, the operating technique, how one goes about getting into the game and, finally, the details of easily-constructed equipment of the latest type.

How many would welcome such a series?



THE CONSTRUCTIONAL details on a specific type of broadcast receiver will appear in the December issue. Get ready for a shock, because it is unlike anything you’ve ever seen before. No trick circuits, but so logical it will hit you right between the eyes.



WE ARE WORKING on a new system by which we hope to provide comparative data on the characteristics of receivers reviewed in the “Radio Proving Post.”

Receivers being what they are, it is too often the case that listening reports alone only confuse the reader. With this system of reporting, a receiver listing at, say \$70, may appear to be equally as good as a receiver listing at, say, \$200.

One of the difficulties lies in the fact that even a single-tube regenerative receiver is capable of receiving signals from Australia. Therefore, reports on stations received mean little, if anything, unless supported by more comprehensive data.

We hope to have the system in operation by next month.

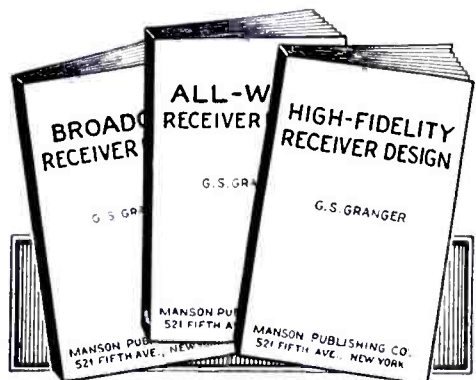

GRANGER TELLS ALL!

CLEAR!

CONCISE!

COMPREHENSIBLE!

FULLY ILLUSTRATED!

**AUTHORITY AND ENGINEER
COMPLETELY COVERS UP-TO-
THE-MINUTE RECEIVER
DESIGN IN THREE
HANDY VOLUMES.**

Explains Circuit Functions
and gives Formulae and
Schematic Diagrams
essential in calcu-
lating Circuit
Values.

*AMATEURS * SERVICE MEN **
*SET BUILDERS * You cannot afford to be*
without this highly informative **GRANGER TRIO**

Printing limited so order your copies today.

**NOW IN USE
IN
20 COUNTRIES**

MANSON PUBLISHING COMPANY
200 Fifth Avenue New York, N. Y.

Gentlemen:

Send me postpaid volumes checked below, for which I enclose \$.....

<input type="checkbox"/> Broadcast Receiver Design.....	50c
<input type="checkbox"/> All-Wave Receiver Design.....	50c
<input type="checkbox"/> High-Fidelity Receiver Design.....	50c
<input type="checkbox"/> Complete Set. Three volumes.....	\$1.00

Name

Address

ALL-WAVE RADIO

FOR NOVEMBER, 1935

BROADCASTING MOVES AHEAD

NEW ADVANCES in radio set design, matching the high-fidelity transmission achieved some time ago; the new metal tubes and further refinements in transmitting equipment, will greatly improve the quality of radio entertainment this season in the opinion of radio's leading technical experts.

Progress In Receiver Design

"Broadcasting has passed from the stage of revolutionary development, to one of continuing improvement," says Edwin K. Cohan, Director of Engineering of the Columbia Broadcasting System. "During the development period transmission improved much more rapidly than reception; sets were not designed to reproduce the full range of sound that could be broadcast, and the highest and lowest frequencies were lost. This accounted for a good deal of the criticism of radio by real lovers of fine music. In the last year or two, however, substantial progress has been made in the receiving end of radio engineering. Recently perfected sets give the same quality formerly heard only in the studio control room, where programs are reproduced at their best, exactly as rendered.

Transmission Improvements

"New transmission improvements have been concerned with coordinating the various engineering elements of broadcasting to make the most of existing knowledge and existing equipment. Individual equipment units such as the microphone, transmitter, or tube, used to be considered solely on their own merits, whether they were good or bad in themselves. Now we think of these factors in the terms of all-over results, how the sounds produced in the studio control room can be brought into the home exactly as they are heard in the control room.

"Saying that a chain is no stronger than its weakest link applies very aptly to broadcasting, starting with the per-

Are the broadcasting stations up-to-date? Are receivers designed to take advantage of wide-range transmissions? How far advanced are the broadcasters? Read what the chief engineers of CBS and NBC have to say about these questions.

former and ending with the listener. Good radio entertainment is dependent on an infinite number of factors, such as studio acoustics, production technique and the coordination of the many engineering elements of transmitting and receiving equipment. A weakness anywhere along the line means imperfection at the listening end. The perfection of all elements in relation to each other has resulted in greater volume range, perspective, clarity and fidelity. The new sets greatly strengthen the whole technique of broadcasting so that a program can now be heard in the home more nearly like the way it is reproduced in the studio control room."

Better Reception

Better reception enables radio's technicians to advance broadcasting quality still further, according to C. W. Horn, Director of Research and Development of the National Broadcasting Company. "The better the receiver," he says, "the more critical it becomes of transmission. Reception improvements enable us to make transmission refinements otherwise impossible. Equipment has been improved all along the line, but the most recent refinements have been largely concerned with better transmitter and antenna design to eliminate operating noise, such as carrier-wave hum, reduce static and other interference, reduce fading, achieve better radiation of the ground

waves from the transmitter, and, in general, increase the service area of the transmitter.

"Another notable improvement enables the transmitter to maintain its assigned frequency with only an infinitesimal possibility of variation. This is of special advantage in matched broadcasting, with more than one station on the same wavelength, as it eliminates beat-notes and other noise noticeable when this type of broadcasting was first practiced. Among the many improvements at the listening end has been a better design of antenna, to eliminate interference in reception."

Transmitters Far Advanced

If transmission had not originally been advanced so far beyond reception, the improvements in set design would have forced the broadcasters to make radical changes. When the National Broadcasting Company moved to its new quarters in Radio City, the company installed equipment so advanced that it would be up-to-date for a long time, to forestall any need for sweeping changes in a relatively short time. At the Columbia Broadcasting System's headquarters in New York, engineers have been busily engaged all summer in completely re-vamping all facilities in accordance with the latest technique of high-fidelity broadcasting. Many individual stations which did not previously modernize their

(Turn to page 93)

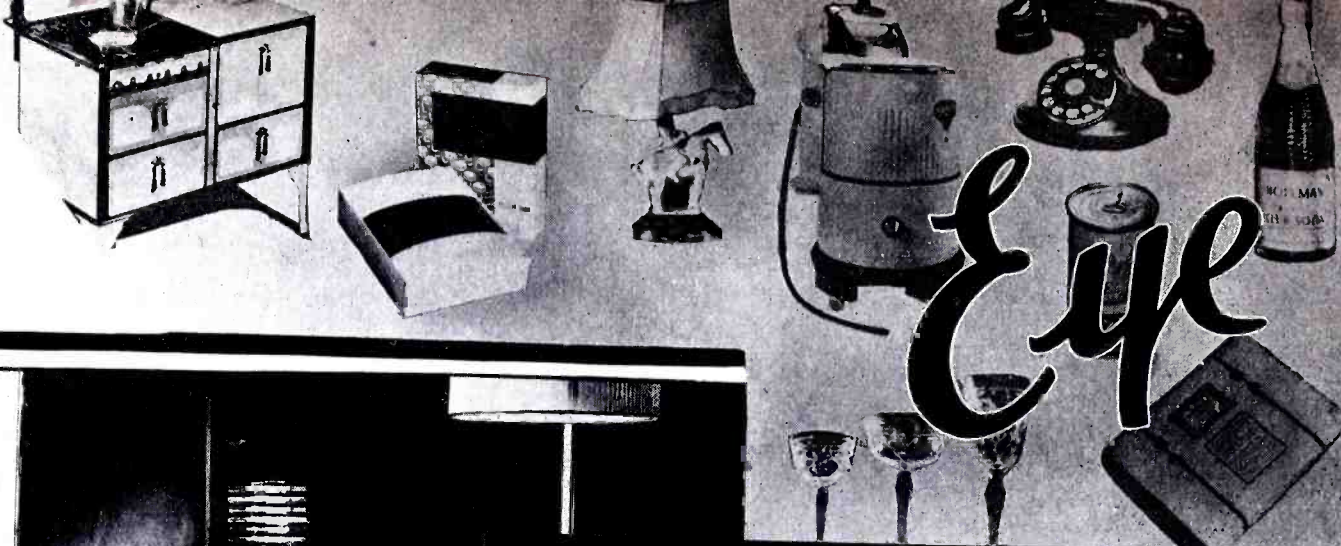

Eye

1936 RADIOS

By G. S. GRANGER

THE TRENDS IN receiver design for this and the coming year have been established. Though some modifications are bound to take place in a few of the present models, manufacturers from A (Air King) to Z (Zenith) have shot the works. All the nice trade secrets were revealed at the recent National Electrical & Radio Exposition, in New York City.

So, the time to buy is now. Prices are up slightly, but these increases are due principally to the inclusion of metal tubes which are more expensive than their glass sisters. Moreover, there is a brisk demand for the 1936 receivers—so much so, in fact, that prices may go even higher than they are at present. For the first time in years manufacturers are finding it difficult to meet orders. In many cases, production is being retarded because the parts manufacturers cannot turn out receiver components fast enough. We'll be surprised, indeed, if there is any "dumping" of receivers in 1936.

Cabinet Design

Eye Appeal?—Sure enough. Cast your eyes over the illustrations on this and the accompanying pages. The trend is "semi-modern," and this fits right in with the trend in the furniture field. The whole country has fallen for this design for the reason, we believe, that the semi-modern design expresses utility, and in doing so is necessarily simple and straightforward. Lines are clean, but not harsh, as they were in the earlier "modern" designs. There are no doo-dads and no "gingerbread" glued on to break lines and otherwise make the cabinet look like grandma's curio cabinet.

The odd thing about this "semi-modern" is that there is nothing modern

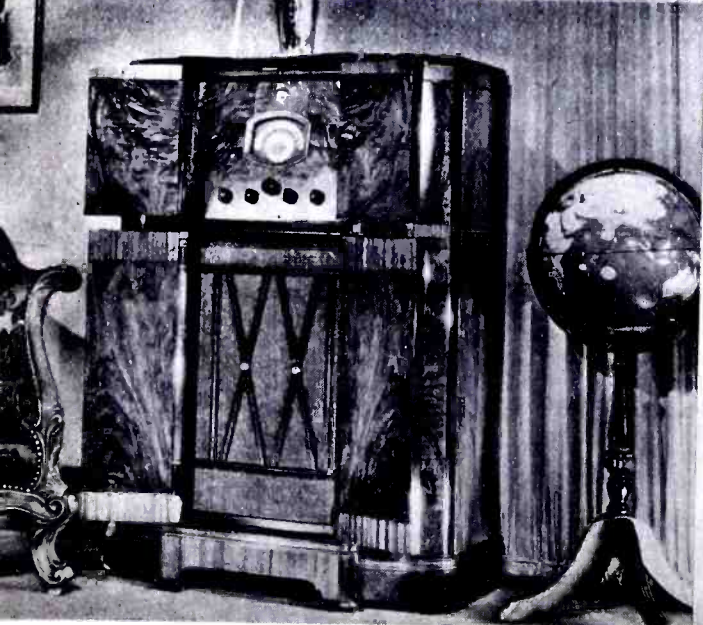
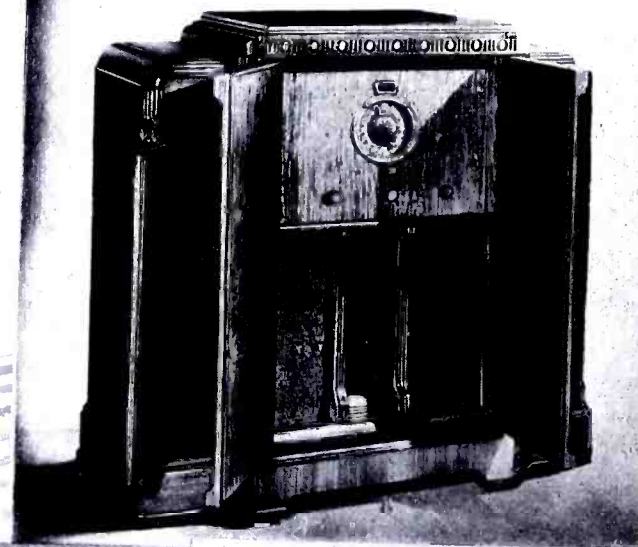
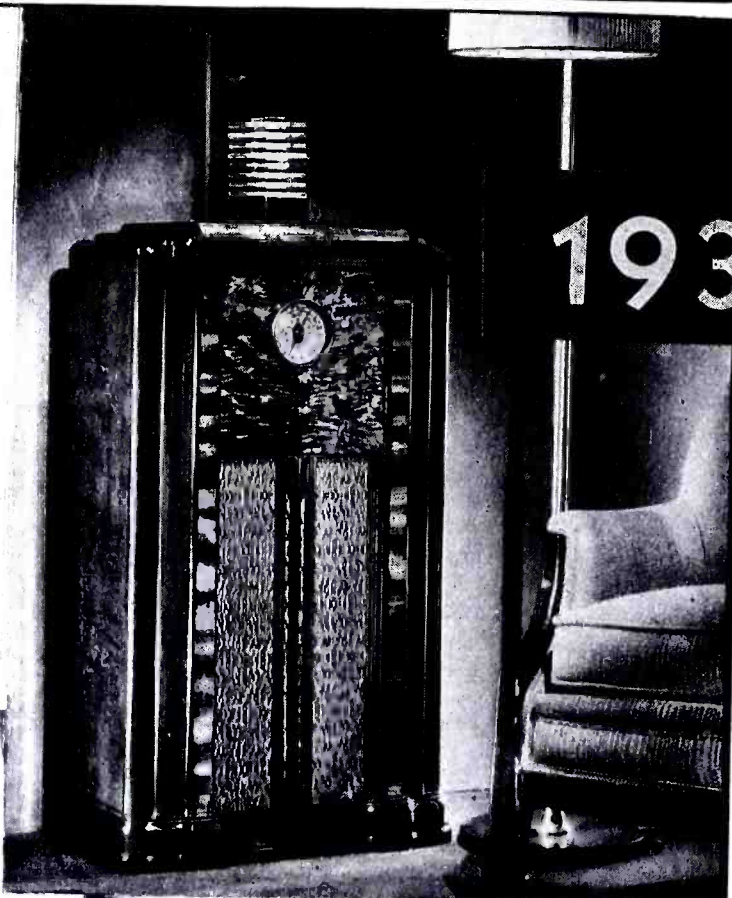

Appeal

HAVE IT

Illustrations Courtesy of RADIO RETAILING

about it. It's a reversion back to the Early American or Colonial, during which "period" furniture was made of maple and mahogany, and was as straightforward as could be. The New Englanders in particular had no use for the dowdy. When they made a table, the only idea they had in mind was that it should have utility—and to hell with the carvings and scrolls that mean nothing to begin with and only complicate the view.

But the radio cabinet is not the only thing—on the face of the cabinet there must be a dial, a loudspeaker opening and various control knobs. Here again, improvements have been made. Rather than attempt to hide dials, the manufacturer has made them larger than ever with the result that they are easier to read and handle. Furthermore, instead of attempting to hide the speaker opening with trick wood carvings so that it would look like a solid, the speaker has been given "breathing space." Here again, utility has been given first consideration. And is cabinet appearance any the worse for this frank manner of design? Not by a long shot! If anything, we would say they are decidedly more pleasing to look at, and certainly easier to live with.

The Chassis

In the meantime, what has happened to the receiver chassis? In what manner does it out-shine the chassis of last year? Considering first the mechanics of chassis construction, you will find upon close examination that most manufacturers have gone in for "floating"—a term and a manner of building borrowed from the auto manufacturer. Floating a radio chassis is as necessary as floating an automobile engine—and it is done for the

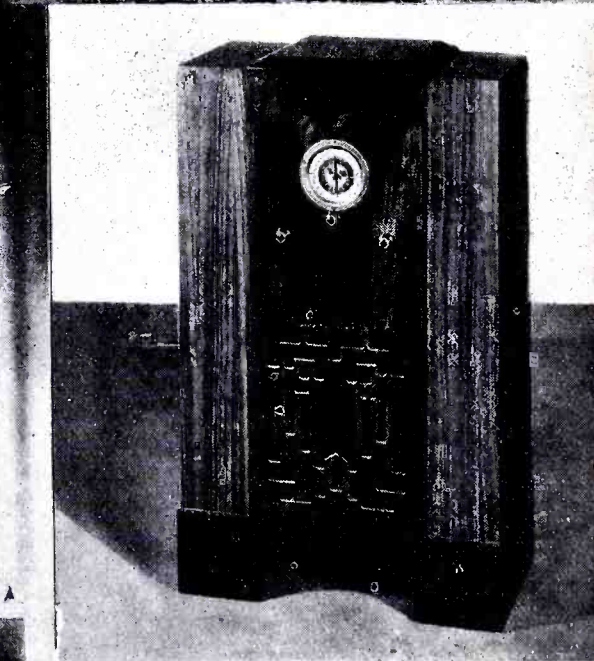
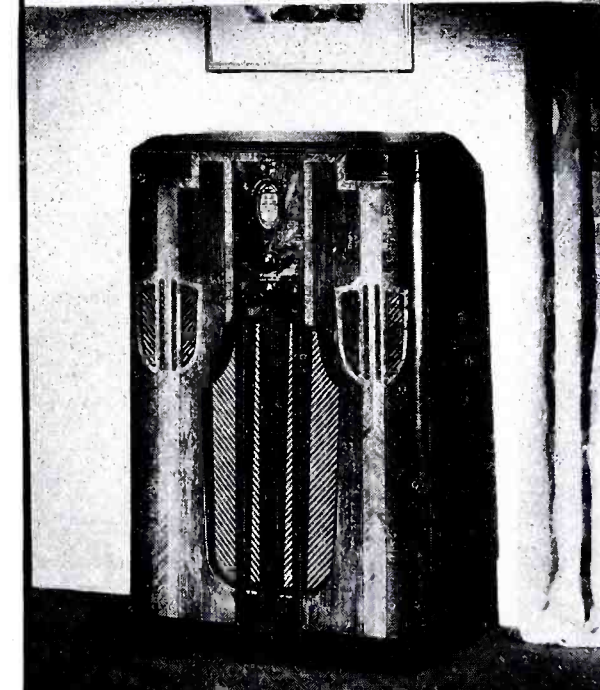
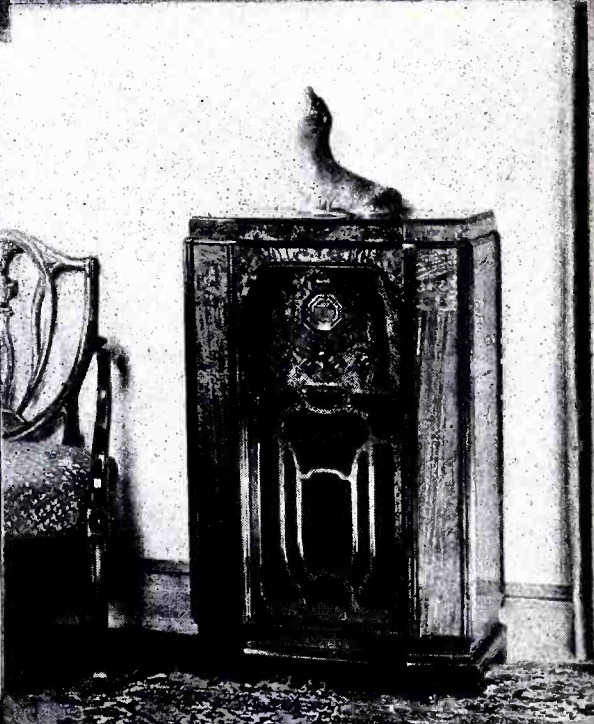
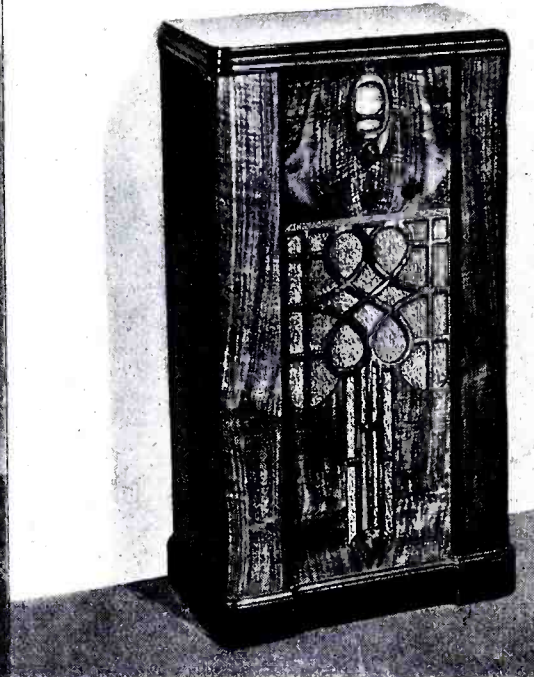
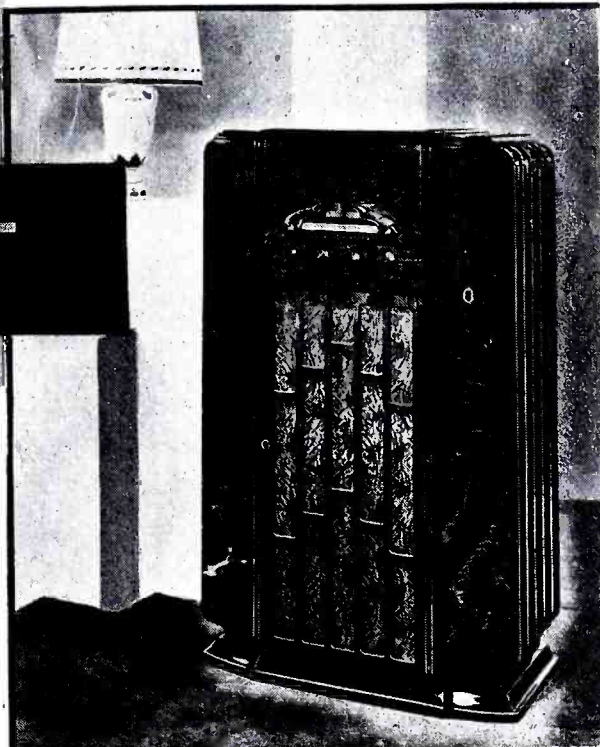

Eye Appeal

1936 RADIOS HAVE IT

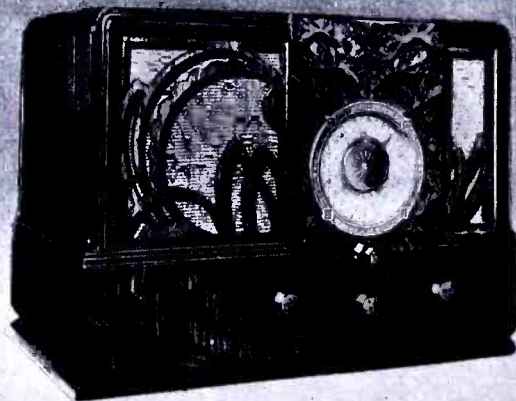
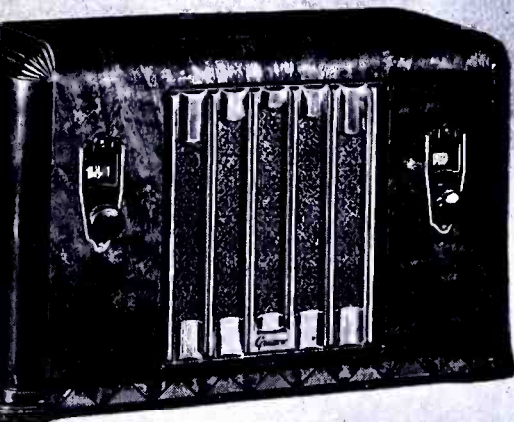
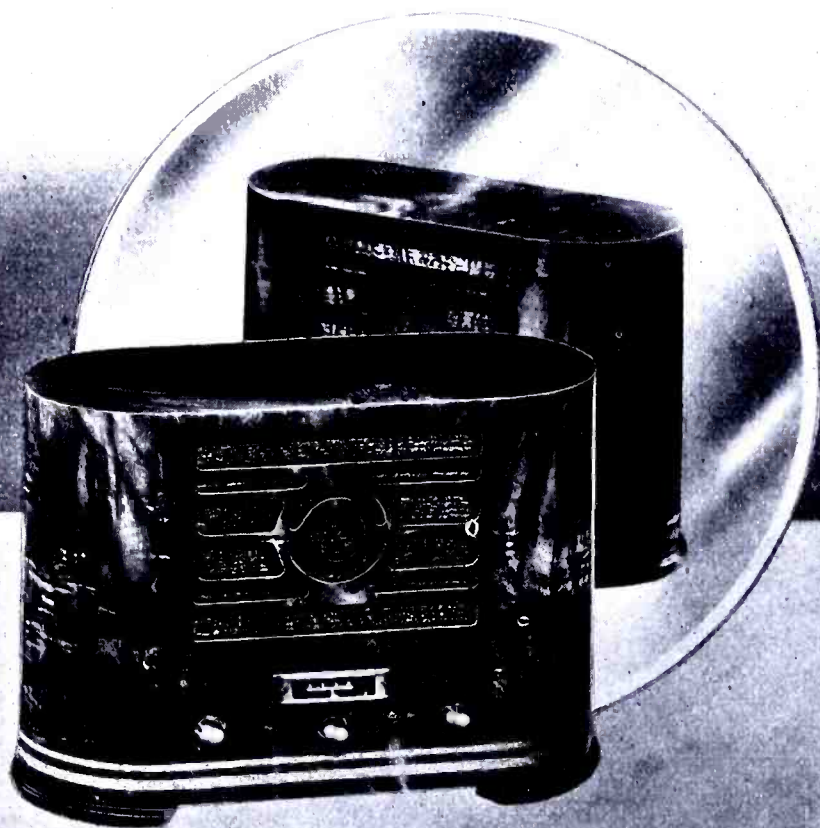
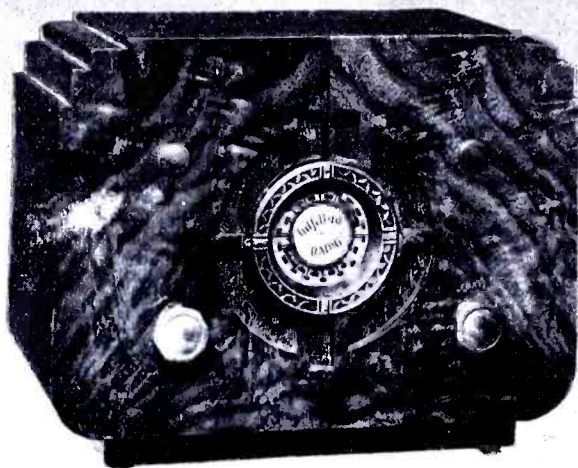
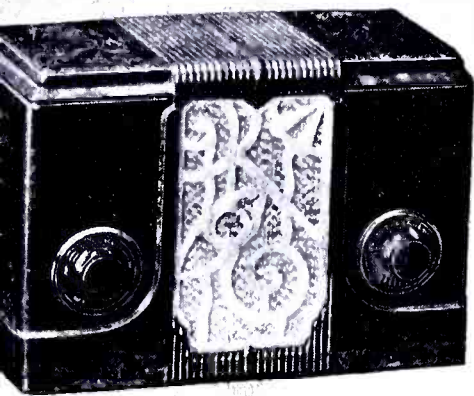

same reason: to defeat vibration. Vibration in a radio receiver is caused by the sound from the loudspeaker, and this can be of sufficient intensity to loosen anchoring screws, alter the electrical adjustment of chassis parts, loosen pilot lights, break soldered connections and set up corresponding electrical vibrations in the receiver tubes of such magnitude as to affect tone quality.

Through the use of blocks of soft rubber, the radio chassis is isolated from the speaker and the cabinet, and the condenser gang from the chassis. Vibrations set up in the speaker and in the wood of the cabinet are absorbed by the rubber and consequently never reach the chassis. Thus the floating of the chassis protects the precise circuit adjustments and at the same time prevents distortion caused by vibration.

Dials

Other mechanical improvements have also been instituted. The new all-wave receiver dials are practically devoid of slippage and backlash, with the result that dial readings are more accurately interpreted. To make tuning in the short-wave bands easier, dial ratios have been increased to as high as 150 to 1, but with the average ratio in the vicinity of 50 or 60 to 1. The latter ratio seems quite satisfactory in the event that there is no backlash and dial readings are clear. The auxiliary or "mechanical band-spread" pointer permits accurate logging even with low-ratio dials, but here again, it is quite important that there be no backlash or lost motion. A few twirls of a dial will determine this. Try 'em out and judge for yourself.

The 1936 sets also have smoother controls. Wave-band selector switches are easier to operate and are more positive in contact. Consequently they are less apt to become noisy, and there is small chance of the knobs working loose. Most of the band switches in the new receivers have additional sets of contacts which operate some form of band-indicating device. These are usually a series of pilot lights, one for each band, which show which band the receiver is set to by the position of the light or by a change in color.

Receiver Circuits

The observer of radio progress may often wonder what possible advancement can be made in receiver design after reviewing a year's crop of sets. It seems to him at times that the design engineer has gone just about as far in one direction as it is possible to go—yet each year a host of new ideas are made known, on top of the fact that, basically, the manufacturer still clings to the standard superheterodyne circuit.

And, again this year, the same basic circuit is found in every receiver, but by

genius and plenty of hard work, the engineer has made it do new things and do the old things in a better way.

Take sensitivity and selectivity, which, though not complementary, go hand-in-hand in receiver design. Sensitivity has not been increased in the modern receiver so much by increases in inherent tube amplification, but by using better components and simplified circuit structure. To begin with, the engineer has tackled seriously the problem of circuit losses brought about by poor or inadequate insulation, by an absence of constant circuit precision, and by the absence of proper isolation between successive stages of amplification. Straight losses have been reduced by using better grades of insulation material in coils and condensers, and by protecting each part from heat and moisture through the use of impregnating compounds. Losses brought on by changes in circuit adjustments have been obviated by the use of air-dielectric con-



One of the 1936 General Electric metal-tube receivers, with the new cylindrical dial scale.

densers, such as the "Permaliner" type used in all the new G. E. sets. Stages have been isolated by increasing the amount of shielding between components and through the use of resistance-capacity filters in each vital tube circuit. Since heat and moisture will alter the electrical values of condensers and coils, these components are not only treated with damp-proofing compounds, but so placed in the chassis that they are well removed from power and rectifier tubes, power transformers and resistors of high-current-carrying capacity, all of which produce plenty of heat.

Central Tuning Units

Special consideration has been given to the input circuits of receivers, for it is at this point that the true sensitivity of a receiver is determined: if input-circuit losses are high, weak signals are intirely lost.

Bosch has reduced the losses in these

circuits by completely redesigning the radio-frequency, mixer and oscillator coil-switching arrangement. The coils used in these stages are fastened directly to the contacts of the wave-band selector switch, with the result that approximately 104 soldered connections are dispensed with, and wire leads simply don't exist. The coils and the switching device form a self-contained unit completely isolated and insulated from the receiver chassis. This "chassis-within-a-chassis" is mounted on rubber pads and, instead of there being a number of individual "ground" or chassis connections which can contribute to noisy operation, there is but one, and this is a flat, braided lead which completes the circuit between the central tuning unit and the main chassis.

Both G. E. and RCA have followed parallel lines in the design of the input stages—G. E. with the "Sentry Box" and RCA with the "Magic Brain." The basic ideas behind these units are the same as in the Bosch "Centr-O-Matic" unit; in each instance sensitivity is boosted where it *should* be boosted, by cutting losses to the limit.

Selectivity has been increased in much the same way—by a reduction in circuit losses, and by the use of at least one stage of tuned radio-frequency amplification in front of the mixer tube, *usable on all wavebands*. For real DX reception, and the absence of station and image interference, an r-f stage on all bands is an absolute necessity.

Selectivity has also been increased in the intermediate-frequency amplifier stages by using transformers having high-Q coils and, in some instances (Fada, and Stromberg as examples) by the use of triple-tuned i-f transformers. In a few instances the Q of the coils has been increased by employing transformers having iron rather than air cores.

Automatic Volume Control

All modern receivers, except some of the midgets, have automatic volume control. The action and effectiveness of this system has been increased in the new sets, and in most instances is so arranged that the *amount* or *extent* of the control action is correctly proportioned for each waveband. In the better receivers this control action has been divorced from the second detector so that one function cannot have an effect on the other. Either a separate tube is used, or the diodes of one tube are used separately.

Amplified automatic volume control is used in many receivers so that the control action will be equally as effective on weak signals as on strong ones. This is highly important in connection with reception in the short-wave bands where extreme fading is the rule rather than the exception.

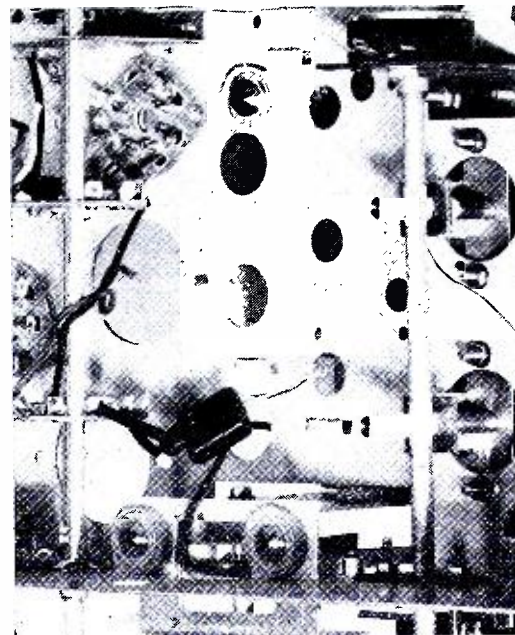

Variable-selectivity control system in a Zenith receiver. Selectivity may be adjusted for "DX" or "High Fidelity."

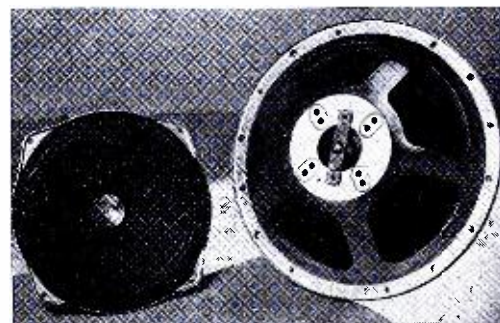

Acoustic Clarifiers used in Philco receivers. These are not loudspeakers, but resonant cones, which eliminate cabinet resonance.

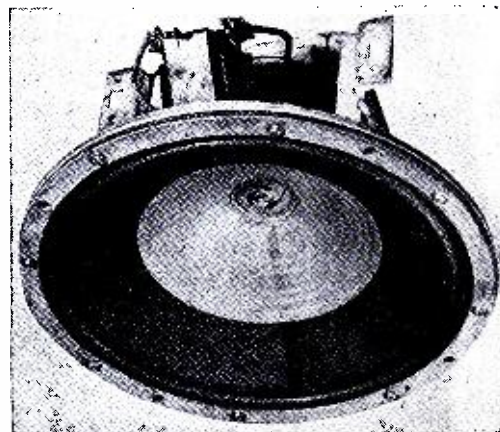

A high-fidelity loudspeaker. This is used in conjunction with the Acoustic Clarifiers, shown above.

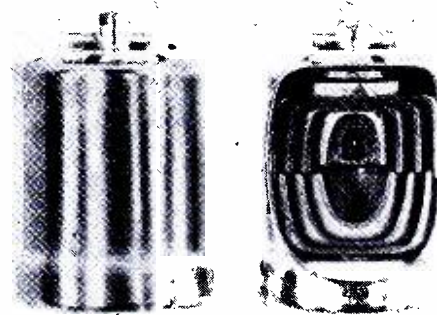

Exterior and interior details of a "Permaliner" (G.E.) This is an air-dielectric trimmer condenser. Advantages: Lower losses, holds adjustment.

Even the CHASSIS are

Different

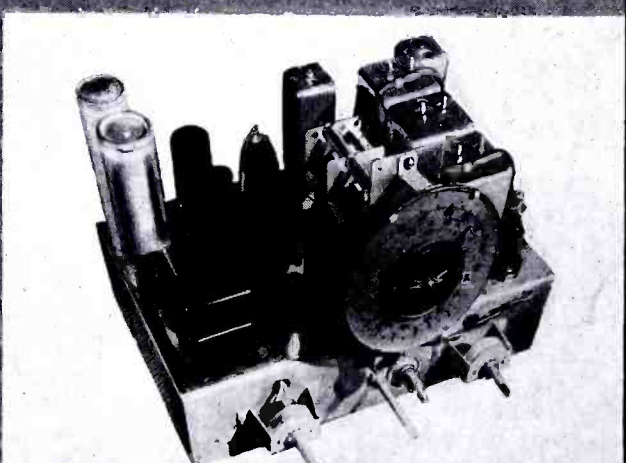
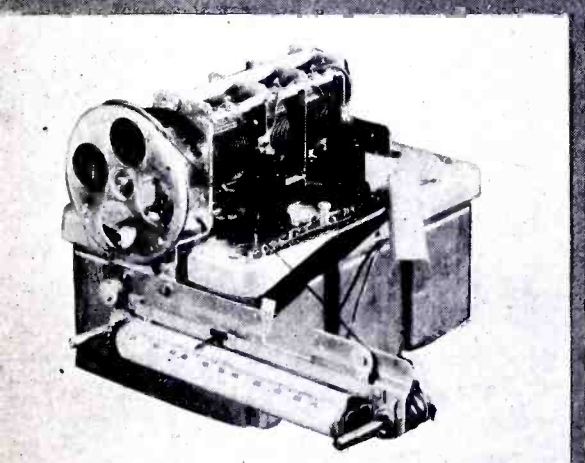
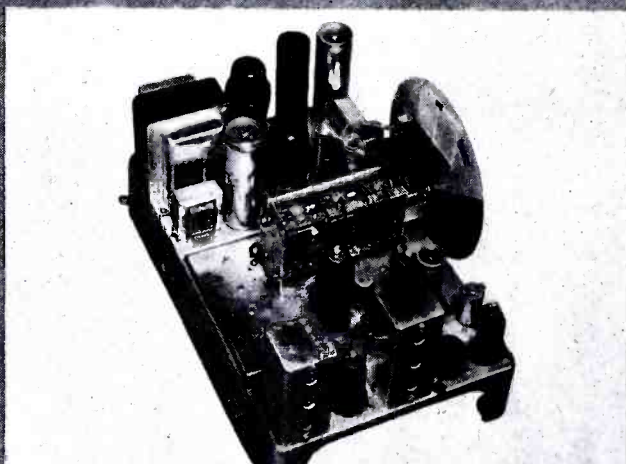
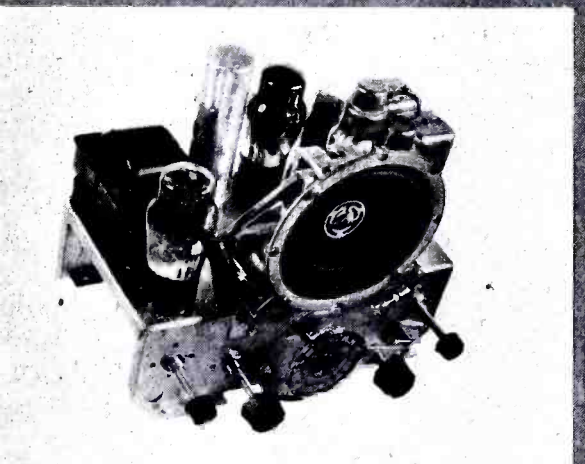
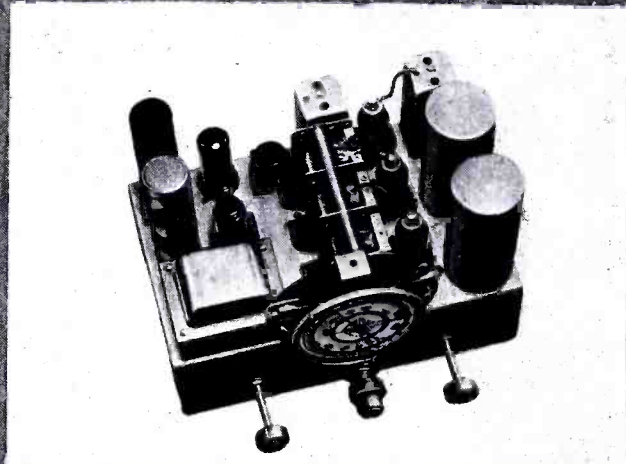
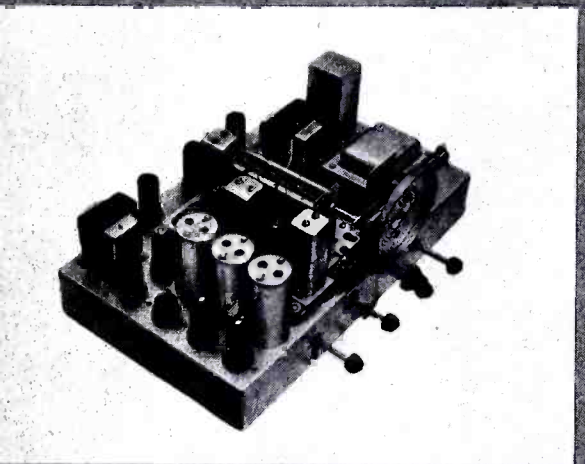
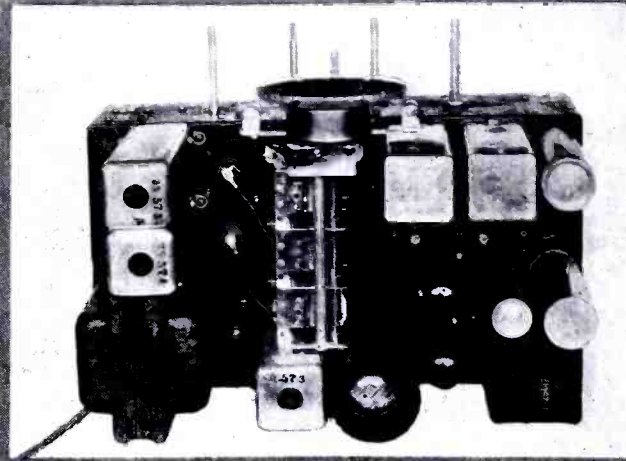
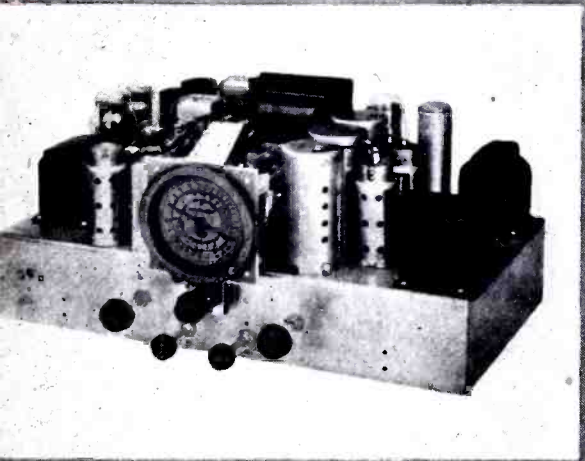

High Fidelity

High fidelity and selectivity simply do not mix. Selectivity is required for DX reception, but the amount of selectivity required to permit inter-station interference defeats tone quality.

In order that all-wave receivers can provide both distant reception without interference, and high-fidelity reception of local broadcast stations when desired, the design engineers have provided the more expensive receivers with "variable-selectivity" i-f amplifiers. The i-f amplifier resonance curve or "band" is contracted to provide maximum selectivity for DX reception, and opened up or expanded for high-fidelity reception. When expanded, the full audio response of the broadcast station is permitted to pass through.

Zenith and Stromberg-Carlson use continuously variable I-F Expanders so that any degree of selectivity may be had. Atwater Kent uses a system controlled by a two-position switch, providing maximum and minimum selectivity. G.E. has one model receiver in which the entire i-f amplifier is cut out of circuit when high-fidelity reception is desired. In this instance the r-f amplifier feeds directly into the detector. Howard uses separate i-f amplifiers for high-fidelity and DX and the tone response is further enhanced through the use of separate audio amplifiers for high and low frequencies.

Audio Amplifiers

There is quite a bit of variety in the audio-frequency amplifiers of modern receivers. Of course, in the smaller receivers using but a single output tube, the pentode is still universally used. But you never can tell what you are going to run into in sets having more than one power tube.

Wells Gardner and Stewart-Warner incline toward the 2A3 Class AB triodes in their larger sets. On the other hand, Stromberg has turned from the 2A3 to the type 42 pentode, but uses the 42's connected as triodes in a Class A Prime circuit. G.E. uses the 6F6 pentodes, as do many of the other manufacturers. In practically every case, however, the pentodes are used in Class AB or A Prime circuits—Class A is practically out of the picture. It is interesting to note, however, that the Zenith "Stratosphere" receiver (\$750, if you're interested) uses two type 42's as drivers for *eight* type 45's in the output! The 45 is still a good tube, and don't you forget it.

ALL WAVE RADIO

Power output is what the manufacturer wants to say it is. Mentioning power outputs—at least *undistorted* power outputs—is as foolish as stating the frequency response of a receiver. Obviously, modern receivers have sufficient audio output to suit most people, and have good tone to boot. But in most cases the statements with regard to output and frequency response should be taken with a grain of salt. It's a harmless pastime with some manufacturers and is no doubt related to the same motive that impels an auto manufacturer to go over-optimistic on the number of miles per gallon you can get out of his cars.

Metal, or Glass, or What?

And now for that burning question. Are the metal tubes better than the glass babies? It's a burning question, all right, and not so easy to answer. But, first, let's see who's using what.

The following manufacturers are using a partial complement of metal tubes in the bulk of their receiver models: Air King, Atwater Kent, Automatic Radio, Capehart, Case, Crosley, Detrola, Emerson, Fada, Garod, General Electric (complete line, all metal), Grunow, Gilfillan, Halson, Howard, International "Kadette" (optional), Midwest (optional), Arvin, Pierce Airo, Pilot, RCA Victor, Remler, Sentinel, Sparton, Stewart-Warner, Stromberg-Carlson, Bosch, Wells Gardner, Westinghouse and Zenith.

Quite a list. Now let's see who isn't using them: Ansley, Autocrat, Fairbanks-Morse, Freed, Galvin, Hammarlund, Lincoln, L'Tatro, Silver, Patterson, Philco and Scott.

Not quite so many in this list, but no reflection on the manufacturers.

Who uses the glass-metal tubes?—that is, the glass tubes with the octal bases? Belmont for one, and with these tubes optional in the International and Midwest receivers.

Will more of the manufacturers take up with the glass-metal tubes? We don't think so. The glass-metal tube is a stop-gap. It was brought out principally to fill in for metal tubes in receivers already produced with the octal-type sockets. Now that tube manufacturers are catching up on production, it is doubtful if the metal-tube shortage will last much longer. As soon as plenty of metal tubes are available, the owner of a set using the glass-metal type can switch over if he wishes. But, since the glass-metal tube has no advantage over the standard glass tube, there is hardly any reason for its continuance and less reason for more manufacturers to take up with it.

The question therefore boils down to the point as to whether set manufacturers sticking to the glass tubes will turn to the

"All - Wave Radio Magazine" — Flashed to New Yorkers from the top of a hotel on Broadway, during the National Electrical & Radio Exposition. The sign was projected on a huge screen, and drew much attention.



metal after the shortage has been taken care of. We believe they will—when, as and if they are satisfied that the metal tube actually has advantages over the glass type. Philco has come out openly and stated that the glass tubes are superior. G.E. and RCA Radiotron are responsible for bringing out the metal tubes, and Philco is responsible for casting suspicion upon them. And, since none of these companies are to be taken lightly, you want to know who's right.

It is too early to provide a definite answer, but this much may be said: Most of the bugs in metal tubes were due to production difficulties which have since been pretty well ironed out. The 5Z4 rectifier was admittedly poor, but we have been advised that this tube has been redesigned. In the meantime, manufacturers have been using the 5Z3 glass rectifier in the metal-tube receivers—and if they should continue to do so until doomsday, it would be no reflection on the regular line of metal tubes. It makes little difference what type of rectifier is used, as the advantages of metal construction are more apt to be apparent in the receiver tubes where improved shielding, sturdier construction and lower capacity between elements really means something. Nevertheless, we wouldn't be surprised if the new 5Z4 turned out to be a superior power rectifier anyhow—but glass or metal, the rectifier tube used in the power supply has only to provide sufficient voltage and current, with good regulation . . . the real work is done by the receiver tubes.

Such tests as we have been able to conduct seem to indicate that the metal tube has a slight edge on the glass tube in the short-wave bands. Both types appear about equal in the broadcast band. It has been our experience that a metal-tube receiver is quieter in operation, a point which has been mentioned in their favor, but not wholly accepted on the face of the assertion.

In comparing metal- and glass-tube receivers, it is unfair to pass judgment on the basis of the number of tubes. Remember that in glass-tube receivers a single multi-purpose tube serves as second detector, automatic volume control and audio-frequency voltage amplifier, whereas in the metal-tube receiver the diode detector and automatic volume control is a *separate* tube. Therefore, a metal-tube receiver has, through necessity, one more tube than an *equivalent* glass-tube receiver.

The present types of metal tubes were purposely made to have characteristics approximately the same as the glass types they replace. Therefore it is unreasonable to expect that the metal tubes should provide far superior results. The point is, it has been demonstrated that the new structural design made possible through the use of metals will yield improved operation in spite of the similarity in characteristics between the glass and metal types. Upon this new structure will be based the tubes of the future—tubes having characteristics unattainable in glass types.

GLOBE GIRDLING

CONDUCTED BY J.B.L.HINDS

WHAT A DIFFERENCE in receivers now as compared with those of the days when we labored to tune in VRY, British Guiana; NRH, Costa Rica; HKA and HKC, Columbia; HRB, Honduras; G5SW, England; F3CID, Indo-China; X26A, Mexico; YV11BMO, Venezuela; CMCI, Cuba.

While these stations, now deleted, have pleasant memories for those who have followed the hobby of DX for some years, other stations have taken their places, and today the advance of short-wave radio finds powerful broadcasting plants in nearly every land transmitting programs of value into our homes, and being received and enjoyed by us through modern all-wave receivers operated from the house line instead of batteries, etc.

"All-Waving"

Today it is about impossible to buy a broadcast set. All manufacturers are building all-wave receivers. Whether some owners of these all-wave receivers do not appreciate the ability of their receivers to bring in distant programs, or are not inclined to find out whether they can or not but simply are content to hear only the local stations, are questions to be answered by the individual alone—but those who follow the DX pastime think that a great many are missing many enjoyable hours by not getting away from their own local stations.

You may, therefore, if you wish sit in your own comfortable chair with your all-wave receiver and listen to consistent reception from every corner of the earth—from stations to the south of us with

their programs of rhythmic native music, fascinating rhumbas, paso dobles or tangoes, which breathe the very spirit of South America, or you may tune in far-away Japan, the "Land of the Rising Sun," where the music and song cannot be mistaken for anything but Japanese. You may listen to the superb programs of England, Holland, Portugal, Germany and France, the marvellous oper-

tion daily from all countries in the world, for there are many conditions to be taken into consideration which make that impossible; but those conditions are being rapidly overcome. With improved receivers and antenna systems and the wonderful advance in broadcasting equipment, in a short space of time we have seen such a marked improvement that nothing seems impossible.

Mr. Hinds received the signals more readily than the Verification Card . . . it is addressed to "Monkess" instead of Yonkers.

atic renditions and music from Italy, keep abreast of the times through the League of Nations stations at Geneva, Switzerland, or twirl the dials and bring the carriers of far-away India, Australia, China, the Fiji Islands, the many transmitters in the Dutch East Indies, or from the heart of Africa.

I will not make the claim however, that you will receive consistent recep-

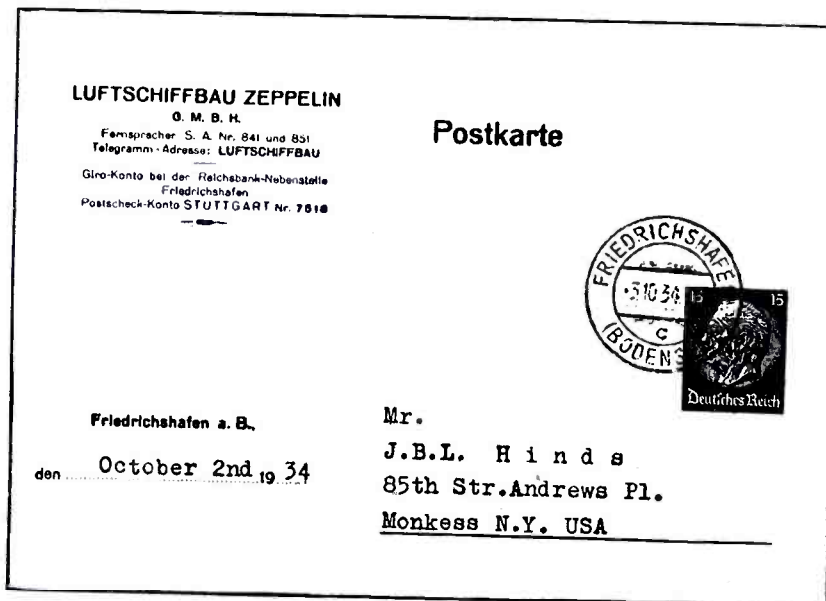

Mr. Hinds in his receiving room, at Yonkers, N. Y.

Station Lists

In revising and compiling the station lists for this issue it will be noted that I have combined the Star Short Wave Broadcasters and Phone and Experimental stations and shown all stations on the air in order by frequency, which I believe will be a beneficial change and materially assist those receiving signals to locate a station more readily. As a great many still calibrate their receivers by wavelength in meters, I am showing the meters for each station in addition to the kilocycles. The information in these tables was carefully prepared and contains only such transmitters that are known to be on the air, being compiled from records of actual contact, operating companies and other reliable available sources.

If one, however, refers to the latest issue of "World Short-Wave Radiophone Transmitters," compiled and issued by the Department of Commerce through the Bureau of Foreign and Domestic Commerce, there will be noted various frequencies assigned which are

not listed in the tables referred to, either due to the fact that they never have been contacted or they are assigned, but not used, frequencies. One should bear in mind that frequencies reported in tables as used at certain periods of the day or night may, of course, be used at other periods than those named.

Many stations such as the Java transmitters, PLE, PMA, PMN, PLP, Italian IRW, IRM, IRG, etc., are classed as phone and are used often in relaying and transmitting programs, as likewise with many classed as experimental stations.

Items of Interest

The popular station EHQ, at Madrid, Spain, is being heard as late as 9:30 P. M. of late, though their schedule for October just received does not show them on the air after 7:30 P. M. at the closing of the International Broadcasting Company's added attraction of EHQ's fine regular program.

ZBW, Hong Kong, China, is coming in quite regularly on 8750 kc or 34.29 meters. Time on the air and address of station are shown in this issue. Their verification card also shows them working on 5410 kc or 55.46 meters, although no reports of reception have been received on the latter frequency.

Information has been received that COC, Havana, Cuba, has been changed to call COCO, and COH, Havana, Cuba, to COCH.

World-Wide Broadcasting Corporation station WIZAL, Boston, advise they will broadcast every Tuesday, Thursday, and Sunday evenings starting October 1st, using 11790 and 6040 kc; power 10,000 watts. They do not say if each program is to be broadcast simultaneously on both frequencies or not, so the same time for each frequency is shown in the tables.

Germany is furnishing verifications for DFC, DFL and other special transmitters, but state they prefer to receive short-wave reports of programs from DJA-B-C-D and E.

A nice one from Java. The border on the card is actually red, not black.

Verification card from VPD Suva, Fiji Island, is headed—"Fiji Islands—The Garden of the Pacific," and states these islands were discovered in 1643 by Tasman and ceded to Great Britain in 1874. There are about 250 islands in the group, total area about 7100 square miles, population about 172,000 of which 4200 are Europeans. Principal exports are sugar, copra, bananas, rubber, cotton and shell. Station operated by Amalgamated Wireless of Australasia, and is being heard regularly on 22.95 meters if you happen to be at your receiver between 12:30 and 1:30 E.S.T. And while you are up, listen for JVH, Nazaki, Japan, between 12 and 1 A. M. on 14,600 kc. Daily overseas broadcasts on this same frequency each Monday and Thursday, 4 to 5 P. M., E.S.T. according to late letter advice. These broadcasts are being heard best on the West Coast but some are hearing the late broadcast in the Eastern states.

OPM, Leopoldville, Belgian Congo, 29.59 meters, broadcast on June 29, July 13 and 28, and August 3, special programs for their National holiday and their exposition held in Leopoldville and has been heard on two or three other dates. The writer was fortunate to hear three of the four broadcasts mentioned

and with fine signal. Late advice would indicate that these special broadcasts have been discontinued.

The time shown on the air for VE9HX, Halifax, is the time of long-wave station CHNS with which VE9HX broadcasts simultaneously when on the air. The latter transmitter has been off the air for a time due to extensive alterations. On Sept. 9th the Maritime Broadcasting Co. advised me they expect to have VE9HX back on the air within a few weeks.

We are still continuing CNR on 23.38 and 37.33 meters as broadcast stations although no one in the East has been hearing them for some time. The writer has written them twice of late with a view to learning the facts, but is unable to learn anything definite; they are simply sending the usual form letter and description of plant, which they have always used in making reply to reports received. I have the subject up at present with authorities in France. These stations were heard with good volume in 1931-1932 and part of 1933.

VE9GW Bowmanville, Canada, has changed its call letters to CRCX.

My good friend J. R. McAllister, of Struthers, Ohio, who builds receivers to bring distance for himself, advises he is again hearing ZTJ Johannesburg, South Africa, between 11:45 P. M. and 12:30 A. M. although signal is disturbed by QRM when W9XF comes on the air. "Mack" is the proud possessor of several bonafide verifications from ZTJ.

ZRO, Rome, Italy, is now on 25.40 meters with afternoon programs. The 31.13-meter band now only carries the American Hour and the South American programs between 6 and 9 P. M.

Verifications

Among the many verifications received of late are interesting ones from ZBW, China; VPD, Fiji Islands; JVN, JVM, JVH, JVT, Japan; PLP, PMC, PMY, Java; SUV, SUT, Africa; OER2, Austria; VP6YB, Barbadoes; PRA8, LSN,

VEREENIGING VAN
VOOR BANDOENG



RADIO - AMATEURS
EN OMSTREKEN.

P. M. Y. Bandoeng, Nillmy-Building.
JAVA, NETHERLANDS INDIES.

We received your useful report on our transmission and thank you very much for it. It checks correctly with the stationlog.

The transmitting-station you heard is located at Bandoeng, Java, in a building, situated in the centre of that city, one of the capitals of the Netherlands Indies.

Our wavelength is 58 meters, power 0,6 kW. Call-signal: PMY.

The Hon. Secretary.

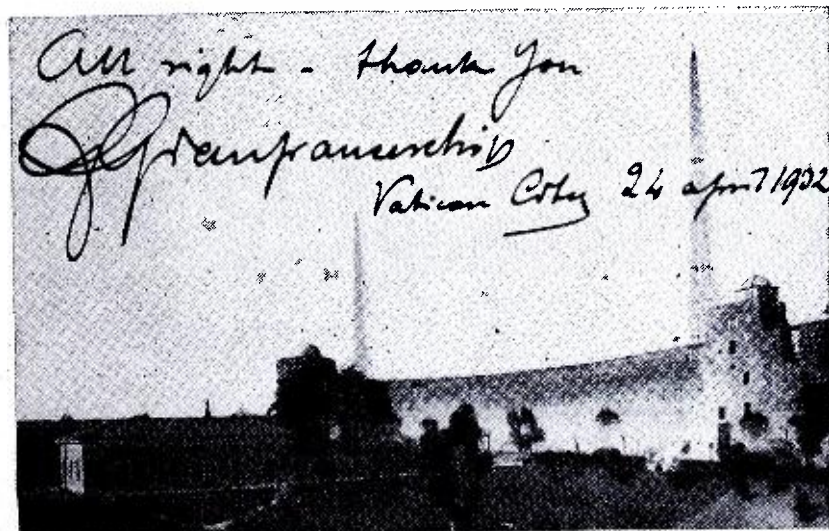

A Vatican "Veri," showing the transmitter.

CEC, HJ5ABE, South America; TIR, TIU, TIRCC, TIPG, Central America; HAT4, CSL, CTIGO, and DGN, Europe; and COCD, CO9WR and CO9JB, Cuba.

An excellent method to preserve your verifications is to place them in scrap books with "Art Corners" so they may be removed and replaced at any time. I have recently cared for mine in this manner in well bound inexpensive books, assigning them in alphabetical order by countries and reserving space by blank sheets between countries. These books come in loose-leaf form and no trouble is therefore experienced in laying them out. An index can be used showing book number, countries assigned to each book, etc., as desired. The different series of postage stamps of each country as taken from the envelopes containing the verifications are posted on the respective page in the book.

New Stations Listed

CO9JQ, Cuba, 8665 kc; ZP10, Paraguay, 8110 kc; CO9WR, Cuba, 11,800 kc; CEC, Chile, 10,670 kc; VPMR, British Guiana, 7080 kc; YV8RB, and YV10RCS, Venezuela, 5880 and 5720 kc respectively; IRG, Eritrea, 14,710 kc, and HB9B, Switzerland, 7118 and 3770 kc,

TFJ, Reykjavik, Iceland, on 12,240 kc, is being heard quite often of late; usually in the morning, testing with England. Letter advice from them states they are usually on the above frequency and transmit occasional musical and other broadcast items and that their transmitter pumps $7\frac{1}{2}$ kw into the aerial and works on a directional aerial towards the East. Their other transmitter is also now testing on 9060 kc. No regular broadcast hours yet assigned.

New Stations Not Listed

New stations reported or heard are as follows: IRJ, Rome, Italy, 14,730 kc, Phone, heard around 6:00 A. M. HJ2ABD, Bucaramanga, Columbia 9570 kc, evenings. PZH, Paramaibo, Suri-

Have you one of these? If you don't know when to listen for Japan, ask Mr. Hinds.

nam, Dutch Guiana, 7140 kc, said to be broadcasting daily until 5 P. M. and 6:40 to 9 P. M. on Mondays and Thursdays. Also a new Mexican with reported call XBJB on about 11,600 kc. The writer heard them testing shortly after midnight on Sept. 15th, with fairly good signal—am requesting that reports be forwarded to P. O. Box 2825 Mexico City. IQA, Rome 14,735 kc, has been heard irregularly of late with musical programs 11 P. M. to midnight. Also reported on voice on other frequencies.

Relay stations VK5WB, Port Adelaide, South Australia, said to be broadcasting experimental broadcasts each Sunday morning between 2 and 3 A. M., E.S.T. 7310 kc. Kookaburra opens each transmission. It is reported that five transmitters have been ordered from Marconi works for Afghanistan to be installed at Kubal, Maimana, Khanabad, Krost and Dujzunga. Kubal transmitter to cover a range of from 15 to 80 meters; output $3\frac{1}{2}$ to $4\frac{1}{2}$ kw and to communicate with Moscow, Tokio, Shanghai, Rio de Janeiro, Capetown and Melbourne. The other transmitters for internal communication and 250 watts each.

The rebroadcast of speech of Emperor Haile Selassie over the NBC network on Friday Sept. 13th was an exceptionally good rebroadcast. The Short-Wave Re-

POST CARD

KOKUSAI-DENWA KAISHA LTD.,

Osaka Bldg., Kojimachiku, Tokyo, Japan.

Tokyo, Oct. 1934

Dear Sir,

Thank you for your kindness of informing us your receiving results of JVM on July 1st, 1934

We are very much obliged to you, if you will kindly let us know your receiving condition of our station in the future,

Your's Sincerely,

Kokusai-Denwa Kaisha, Ltd.,
(International Wireless Telephone Company of Japan, Ltd.)

per. S. Kuramochi

Mr. J.B.I. Hinds
85 St., Andrews Place,
Yonkers, New York,
U.S.A.

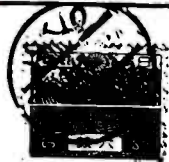

porter (2RC) Hendersonville, N. C., reports direct reception of the s.w. station in Addis Ababa, Ethiopia, transmitting the broadcast mentioned on 18,270 kc and a later broadcast on same date at night. Call letters ETA. The writer heard the rebroadcast but was not fortunate in contacting either frequency on that date. It is said more broadcasts will follow.

A station is being heard and reported as HC2CW, Ondas de Pacifico, Guayaquil, Ecuador, on about 840 kc or 35.69 meters. Some believe it is the same station as HC2AT which has been broadcasting on and around that wavelength, but which was reported by some as closed down, but by others as still being heard. The writer received advice from HC2AT a short time ago that they were shortly to increase their power but no mention of leaving the air. Schedule of HC2AT is therefore still reported in list.

On Wednesday and Saturday of each week between 5 and 7 P. M. E.S.T. a little 50-watt station CT2AJ at Ponta Delgrada S. Mignel, Azore Islands, can be heard broadcasting programs on 4000 kc or 75 meters. Tune to the high-frequency side or end of the 75-meter phone band until you hear no more U. S. amateur phones and then slightly back off the dial. While I have not heard this station, others have a verification.

An official communication from the Swiss Short-Wave Association (USKA) of Bern, Switzerland, announce that short-wave broadcasts are to be radiated the first Monday of each month from several Swiss stations. These programs have been arranged for Oct. 7th, Nov. 4th, Dec. 2nd, Jan. 6th, and Feb. 3rd. Will be broadcast 3:10 to 4:15 P. M. E.S.T. over HB9B, 14,236 kc, with a beam aerial to North America; HB9H, 7005 kc, with uni-directional aerial for Europe, Australia, North and Central Africa, and HB9J, 14,400 kc, to South and Central America. In order to secure a world-wide coverage program will be repeated on same days from 6 to 7

(Turn to page 96)

Another "Veri" from Java . . . as valuable to the owner as a rare stamp.

J. B. I. Hinds

BANDOENG, August 21th, 1934.

Dear Mr Hinds,

Your report on station P L V , 9420 kc/sec, dated June 28th, 1934. checks correctly with the station log.

Thank you.

H. Van der Veen
H. VAN DER VEEN,
Engineer-in-charge,
Java Wireless Stations,
Bandoeng, Java.

WORLD WIDE RADIO

A receiver designed to "step out"—not to provide the best quality and high power output. Compact, completely shielded, no frills — a Greyhound of the Air.

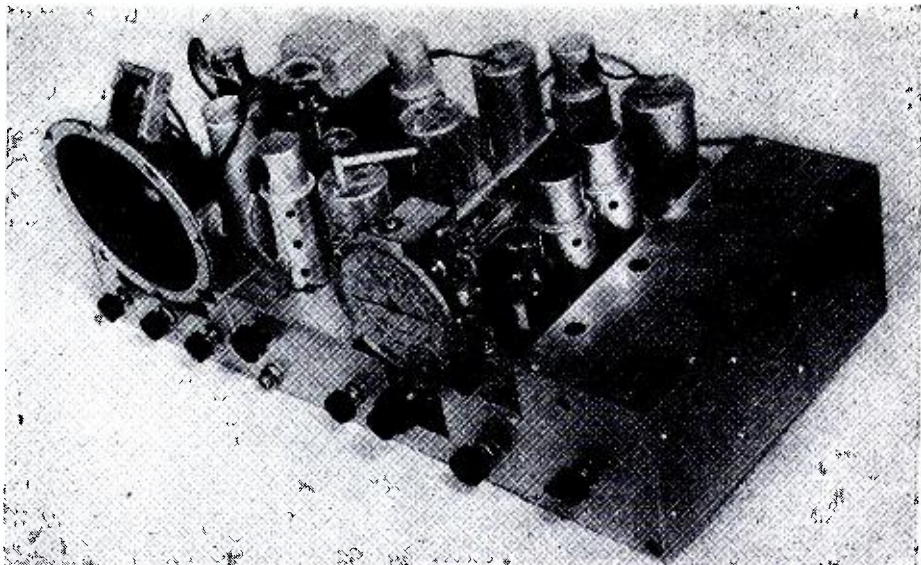

FIG. 3

The Lafayette Professional Nine

A WELL-KNOWN engineer recently purchased a console receiver costing over \$200, for the express purpose of using it for listening in on the short-wave bands. He selected a good receiver, and it must be said in all fairness to the manufacturer, that it worked exceedingly well. However, after using the receiver for some time, this engineer was frank enough to admit that, since he wished a receiver for the short-wave bands only, he could have saved himself quite a bit of money and in the bargain obtained a receiver designed principally for this one class of service, had he given thought to the numerous sets designed for amateur use.

What You Pay For

This is undoubtedly a point which has been given very little consideration by the man who is interested primarily in distance reception on all the usual wave

By FRANK LESTER
WHOLESALE RADIO SERVICE, INC.

bands covered by an all-wave receiver, and only secondarily in what is usually referred to as "tone quality," but upon analysis turns out to mean the capability of a receiver to turn out more power than can be comfortably used in the home for any purpose other than the reproduction of symphony concerts and recorded music.

This is a very interesting point, in that it demonstrates what the manufacturer of any specific type of receiver does with his pennies. If, for example, we take \$60 as a fair price for a table model all-wave receiver having a good sized dynamic speaker and a Class AB push pull output stage, it is apparent that a fair percentage of the cost has gone into the cabinet for one thing, into the dynamic speaker

for another, and also into the power output stage. Now, if "living-room beauty" is of no consequence, fine tone quality of only passing interest, excessive power output of no regular value, but distant reception qualities the prime requirement, it is obvious that if some of the \$60 tied up in the cabinet, the speaker and the power stage, were used instead to provide increased sensitivity and selectivity, the DX man would get more for his money.

Professional Receiver

Undoubtedly there are any number of people who wish to have the features of high sensitivity and selectivity in an all-wave receiver without having to pay an excessive price for it. That is why there is presented here the circuit and constructional details of a moderate priced professional receiver, designed specifically for amateur use, which may be purchased complete or in kit form. The reader will appreciate as we progress with the description of this receiver that it contains features of importance to the DX listener not to be found in the general type of all-wave receiver for home use.

The Circuit

The complete schematic diagram of the Lafayette Professional Nine is shown in Fig. 1. Starting from the upper left of the diagram it will be noted first of all that there are four wave-band positions and that separate sets of coils are used for each band. The coverage is continuous from 9.7 to 560 meters.

There is a stage of tuned-radio-frequency amplification which functions on all four bands. This stage, using a type 6D6 tube, is transformer coupled to a 6C6 type tube which is used only as the first detector or mixer. A type 4I pentode, connected to function as a triode, is used as the high-frequency oscillator.

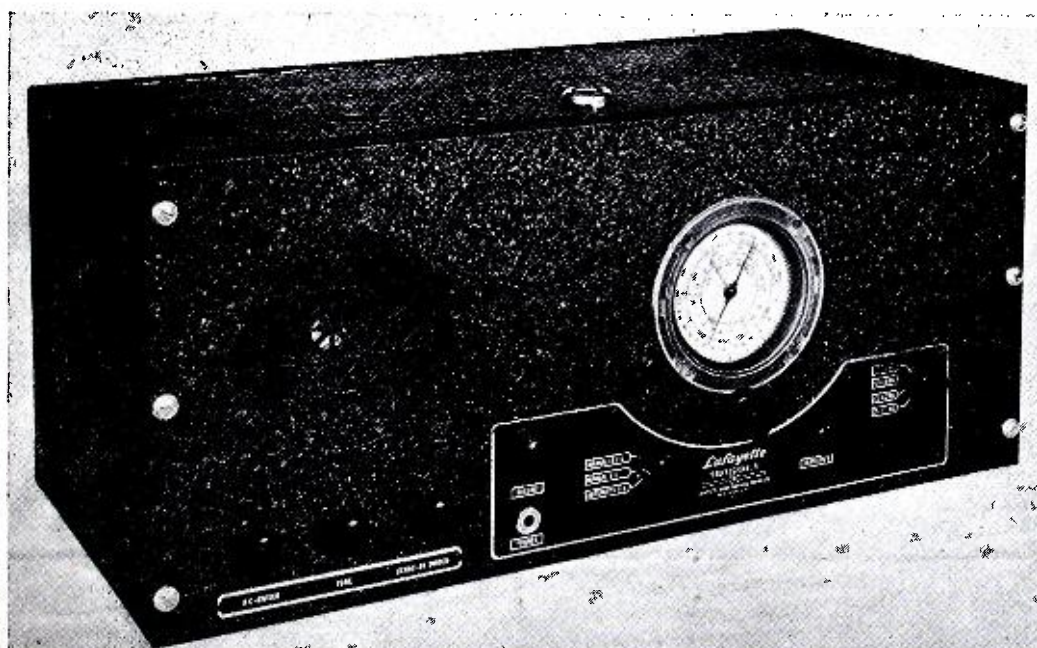

Fig. 2. The Lafayette Professional Nine. Speaker at left, dial at right, controls below—well balanced throughout.

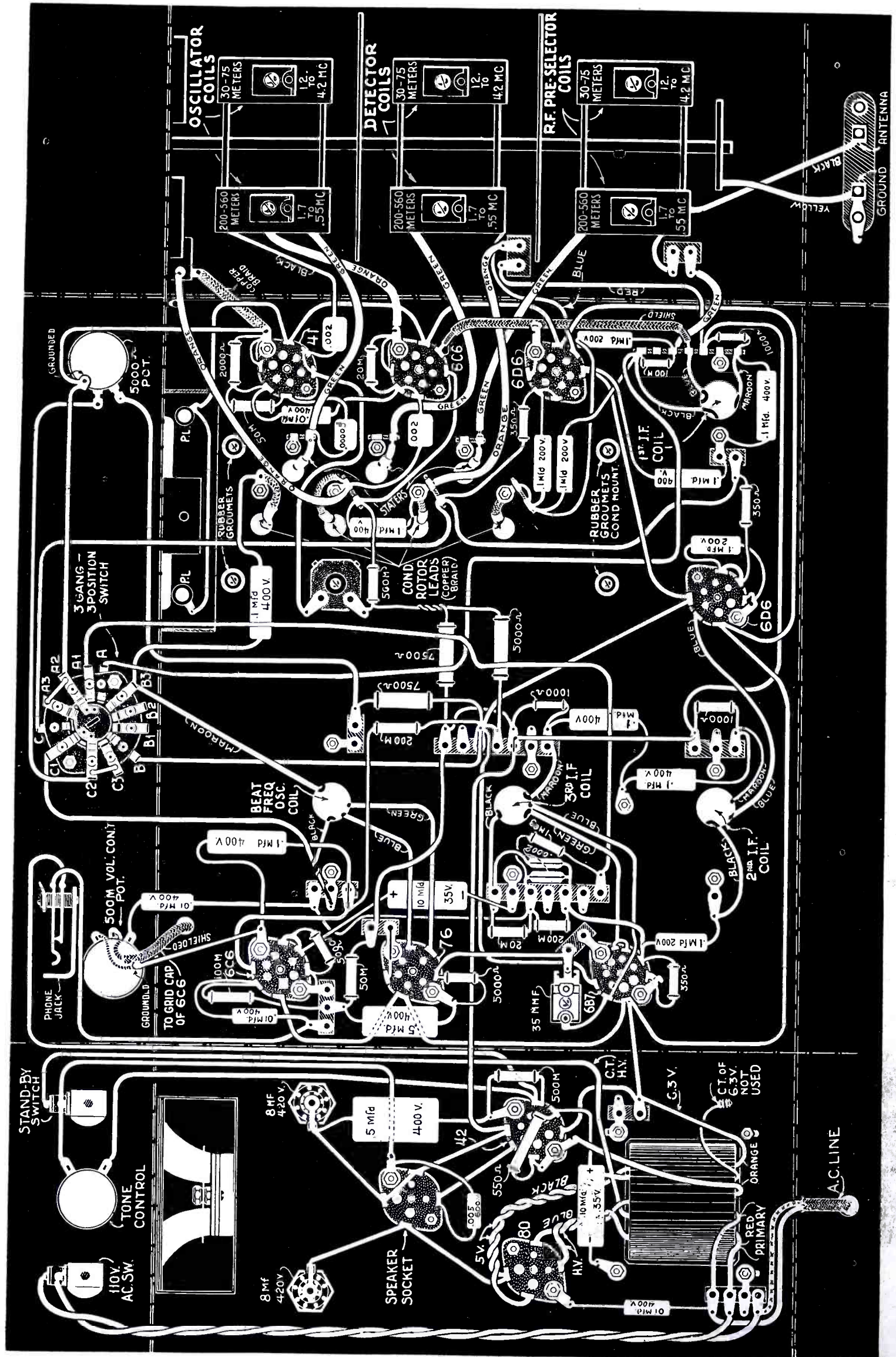

FIG. 4. COMPLETE UNDER-CHASSIS WIRING OF THE LAFAYETTE PROFESSIONAL NINE. TOP AND BOTTOM SHOW WIRING TO COMPONENTS MOUNTED ON CHASSIS WALLS.

Due to the high transconductance of this tube it has a high degree of stability on the shortest wavelengths where many other types of tube fail to function satisfactorily as high-frequency oscillators.

The output of the 6C6 first detector is fed into the first intermediate-frequency amplifier stage, which uses a 6D6 tube. There is a second i-f stage in which is employed the pentode section of the 6B7 tube. The plate circuit of this tube feeds into the primary winding of the third i-f transformer, and the secondary winding of this transformer feeds the diode plates of the 6B7 which are connected in parallel and provide both rectification of the signal and automatic volume control.

There is included in this diode circuit a load resistor across which appears the direct-current component of the rectified signal. This voltage is used to provide automatic control bias on the 6D6 r-f tube and on the 6D6 i-f tube. The audio-frequency component also appears across the load resistor and this is fed through the volume-control potentiometer, the arm of which connects to the control grid of the 6C6 audio frequency voltage amplifier tube.

The 6C6 audio tube is resistance coupled to a type 42 pentode power tube. A phone jack is connected in the plate circuit of the 6C6 a-f tube so that headphones may be used for weak-signal reception. When the phones are plugged into the jack the output of the 6C6 a-f tube is automatically disconnected from the power tube.

A variable-condenser type of tone control is connected in the grid circuit of the type 42 pentode and proves very

handy for reducing background noise and certain forms of inter-station interference.

The type 42 pentode feeds a dynamic speaker the field coil of which is used as the filter choke in the power supply unit which employs a type 80 tube.

It will be noted in the lower part of the diagram that there is a type 76 tube used as a beat-frequency oscillator. This oscillator not only permits the reception of cw code signals but is also valuable as a broadcast-station finder. It will indicate the presence of a modulated or unmodulated carrier by a high-pitched sound when the dial pointer is passed through a station.

Special Control Switch

Now take note of the tandem switch shown in the diagram just below the 6C6 first detector tube. Section A of this switch cuts in and out the automatic volume control action. When the arm of this section is on Point 1, automatic bias control is placed on the r-f and i-f tubes. When the arm of this section is on either Point 2 or 3, the grid-return circuits of these two tubes are grounded as they would normally be with no automatic volume control circuit.

Section B of the switch is inoperative until it reaches Point 3 when it places high voltage on the plate of the beat-frequency oscillator and so places it into operation.

Section C of the switch connects the cathodes of the r-f and i-f tubes to ground when automatic volume control is being used, so that both of these tubes will be supplied with residual bias, developed in each case by a 350-ohm resistor. With

Section C on either Point 2 or 3, the cathodes of the r-f and i-f tubes are connected to ground through a 5000-ohm potentiometer which serves as a manual sensitivity control by varying the bias on these tubes.

Reviewing the function of this tandem switch, composed of Sections A, B and C, it will be seen that with the switch arms on Points 1, automatic bias control is placed on the r-f and i-f tubes and the cathodes of these tubes connected to ground. With the arms on Points 2 the automatic volume control action is cut out and the sensitivity or gain control is thrown into circuit so that the operator may adjust the gain or volume of the receiver manually. With the arms of the switch on Points 3 the sensitivity of the receiver is still controlled by the manual gain or volume control and, in addition, the beat-frequency oscillator is brought into play. Since automatic volume control cannot be effectively used when receiving cw signals, no provision is made to have it thrown into circuit when the beat-frequency oscillator is on.

A front view of the receiver is shown in Fig 2. The controls from left to right are: On-off switch; tone control; standby switch, which cuts off the "B" supply; volume control; automatic volume control switch; tuning control, which operates the double pointers on the airplane dial; the sensitivity or gain control; and, lastly, the four-position wave-band switch.

A view of the chassis is shown in Fig. 3. This is so constructed that if it is found desirable, the left-hand unit containing the speaker, the power amplifier and the power-supply unit, may be taken

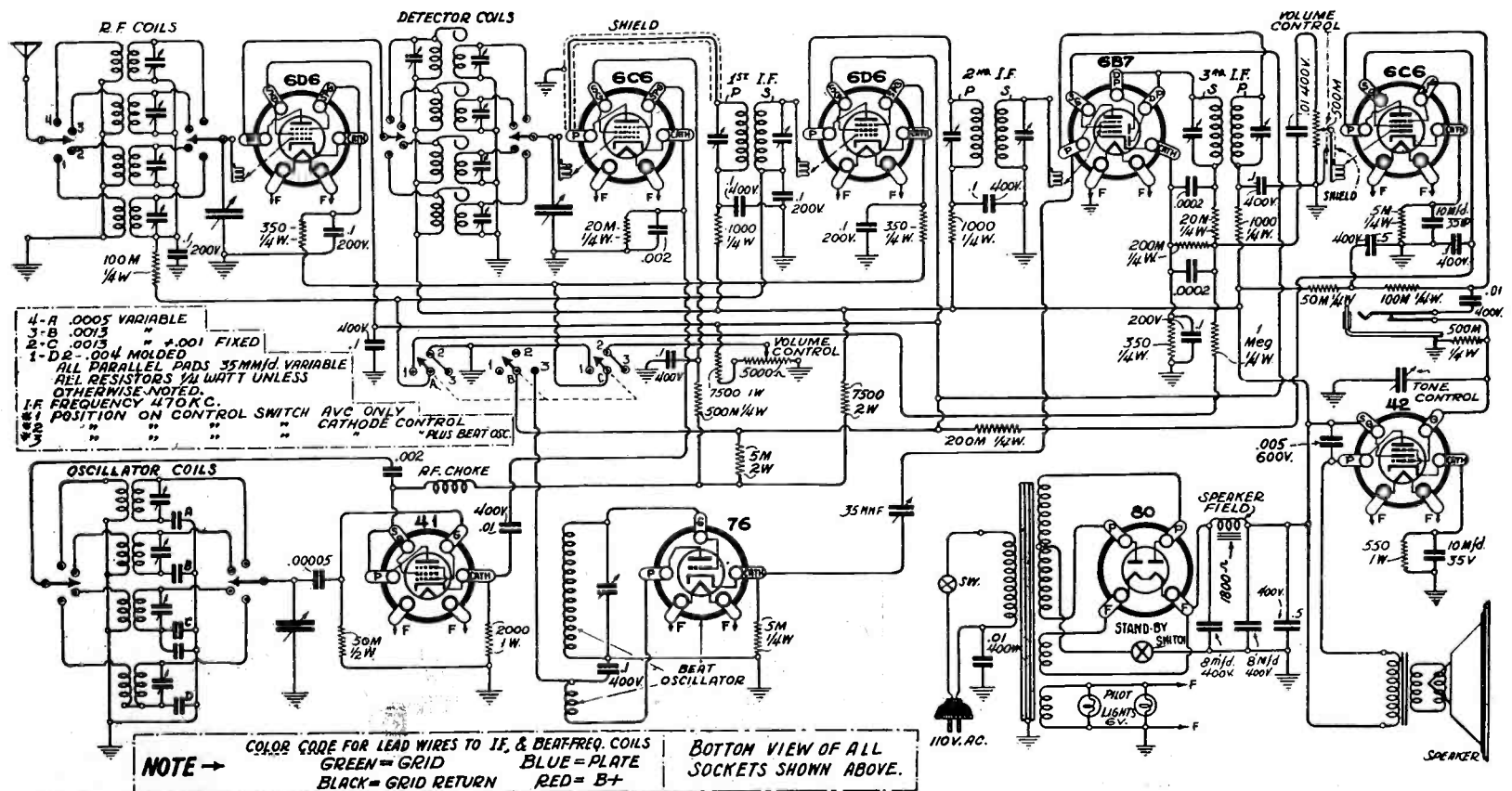

Fig. 1. The schematic diagram of the Lafayette Professional Nine. See text for explanation of tube and circuit functions.

out of the cabinet and mounted some distance away from the receiver proper.

Assembly Procedure

It will be noticed that the chassis is supplied in three separate parts, one part of the chassis incorporating the power supply and output audio stage, and the other part the tuning condenser and dial, along with all of the intermediate frequency stages, and last, the completely assembled, wired and tracked coil switching arrangement. Each of the coil switching arrangements have been carefully tested. It is therefore absolutely imperative that none of the trimmer adjustments are varied, unless one wants to be extremely critical, and after the receiver has been completely wired, make some slight adjustments of the parallel trimmers. Needless to say this procedure should not be attempted unless a calibrated oscillator is available that will cover the wavelength range of this receiver. Great care has been taken in properly tracking and aligning this coil switching unit, and it has been found that if the picture wiring diagram is closely adhered to, absolutely no trimming of the various tuned circuits will be necessary. The intermediate-frequency transformers are also supplied, tuned approximately to the i-f frequency, and therefore it is almost certain that as soon as the receiver is turned on, some signal will be heard, providing, of course, it has been wired correctly. In assembling the chassis, it is advisable to start with the middle section, namely, the one incorporating the tuning condenser. First mount all of the tube sockets, intermediate-frequency transformers, beat-frequency oscillator, etc. When mounting the tube sockets, be sure and include the base of the tube shield on all of the sockets shown in the drawing as shielded. Now, carefully inspect the picture wiring diagram shown in Fig. 4, and next mount all of the small terminal strips in their correct position. Do not mount the variable condenser or dial assembly, until you have completed all of the necessary wiring of this portion of the chassis, or, as a matter of fact, this can be left until the last procedure; or in other words, after the complete receiver has been wired.

Wiring

It will be noticed that one side of the filament or heater is grounded to the chassis on all tubes, with the exception of the 80 rectifier. All tube filament wiring should now be completed and it will be found a good procedure to next wire all grid circuits, then all cathode circuits, and finally, all plate circuits. While wiring this portion of the chassis, it is advisable to mount the avc beat-frequency oscillator, and manual volume control switch, as well as the two volume

controls, when the particular circuit you are wiring calls for some connection to be made to these controls. After you have practically finished the middle section of the chassis, this should be laid aside for a few moments, and the power supply section completely assembled and wired, according to the picture diagram. When this has been completely wired with the possible exception of the two condensers near the joining point of the two chassis, the six screws supplied for bolting the two sections of the chassis together at this point, should be employed for this procedure, and when this is finished, the two condensers mentioned above may be mounted with ease. If you have not already wired in the a-c on and off switch, tone control, and standby switch, these controls should now be wired in, along with the phone jack.

Mounting Variable Condenser and Dial

You are now ready to mount the variable condenser and dial assembly. In the mounting of the variable condenser, it will be found that eight metal washers are provided, in addition to four rubber gromets. The rubber gromet is used on each side of the chassis with a washer each side of it, and the fastening screw through the center. There are four separate ground pigtail connections brought from the variable condenser, and these ground connections should be made to the specified position on the chassis, which will be clearly noted in the picture wiring diagram. The dial should next be mounted, employing the special bracket supplied. This bracket fastens to the top of the variable condenser, which is mounted on one of its sides. The side that the variable condenser is mounted on, is the one farthest away from the shaft. This side may or may not be already equipped with mounting brackets. After the dial has been mounted, the two pilot lights should be connected, one side of each of these pilot lights being grounded to the frame of the dial, and the other

side connected in parallel, and then a wire brought down to the ungrounded filament or heater connection of the 41 oscillator tube.

Mounting and Wiring Coil-Switching Compartment

The coil-switching compartment of the chassis should now be fastened to the wired portion of the chassis, and the leads connected to the points clearly illustrated in the picture wiring diagram. The three green leads starting from the front of the coil switching unit, are the three stator connections to the variable condenser. These three leads are approximately 3 to 4 inches long and should be kept away from the chassis by at least an inch or an inch and a half. The fourth green lead is a short one about 2 inches long, and connects to the terminal strip mounted near the rear of the coil switching arrangement. One side of the 100,000-ohm resistor, which is also mounted on this terminal strip, also connects to this point. The tuning unit will also be found equipped with three orange colored leads, two being long, and one short. The long lead near the front of the panel should be connected to the same point on the chassis, as the second copper pigtail coming from the variable condenser. The other long orange lead coming from the middle coil section should be connected to the same point on the chassis, as the third lead from the variable condenser. The short yellow lead should be connected to the ground lugs, or grounded side of the filament of the 6C6 tube socket, near the coil-switching compartment. These various ground connections are important, and therefore, care should be exercised in trying to get them in the exact place specified above, as well as we have tried to clearly indicate on the picture diagram.

After you have completed all of the wiring it is advisable that you thoroughly check over both the schematic diagram
(Turn to page 95)

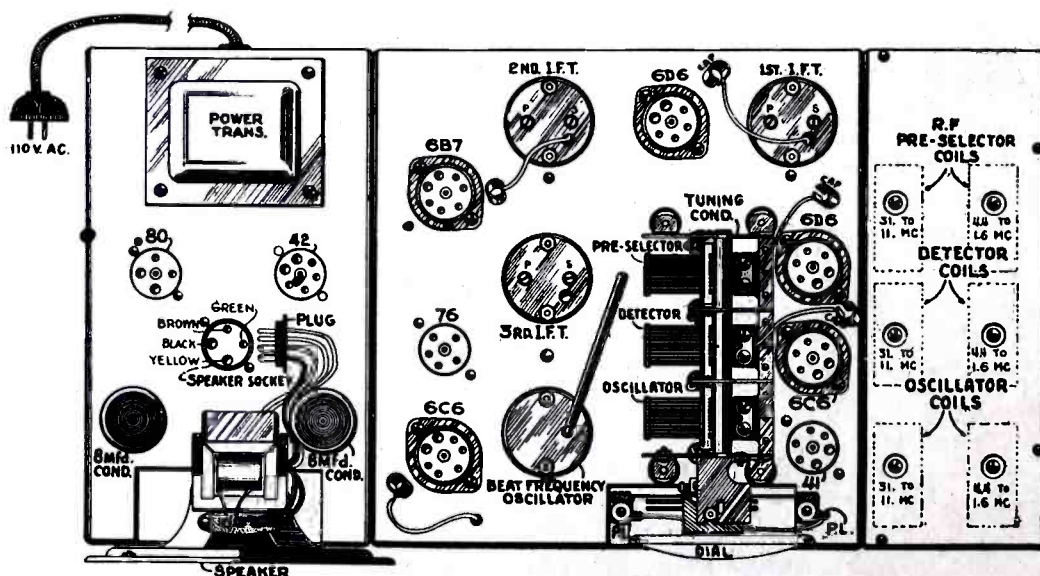

Fig. 5. Respective location for each part on the triple chassis.



By BEAT NOTE

A BOUQUET OF Tube Roses to that dramatizer of radio technicalities, John Mills, who has created for lovers of music the entertaining book "A Fugue in Cycles and Bels," which tells what electricity is doing for music—and to the publishers of the book, our warmest regards for having tickled us no end with the spicy bit of information, framed in their own words, that "the location of one's seat makes a great difference in the music of a violin solo."

◆
 "GIVE BEAT NOTE a shot of corn juice; he's good now, but . . ." (From a letter by Z. A. Ridgeway, San Diego, Calif.)

Never had I left that trophy room without turning my head just a wee bit to catch a last, guarded view of the Bengal Tiger.

Though I had slain her with my own hands, the impression had always remained with me that there was life in the old cat yet. Stuffed as she was, the one good eye she had left would glare and glitter at the most unexpected moments. Yet the vacant socket through which I had once plunged my dagger to the hilt, bore mute (or would one say blank) testimony that the she-devil was as dead as a blown bottle.

It was with no great surprise, then, that one night about half after one, as I felt my way into this darkened chamber, there came to my ears the low, fearsome hiss of the Jungle Cat ready to make its kill—and with no more surprise that I saw cutting through the death-like blackness of that chamber the evil, green gleam of that one, good eye.

My days in Africa taught me never to retreat before the Cat of Cats. So, gripping the neck of the bottle—now completely drained of corn—I slowly advanced until, eye-to-eye with my antagonist, I let loose with all I had . . .

I am told that I was found sprawled on the floor at the foot of my brand new RCA Victor Magic Eye radio; out like a light. Out as well was the Magic Eye, its glass intimately mingled with the remains of what once had been a bottle of good cheer.

◆
 HAVING FOCUSED your attention on the Magic Eye, permit us to make lip noises at the engineers who contrived this cat-like optic, for having completely missed the opportunity of a lifetime.

We offer to RCA—free of charge and minus all incumbrances—the "Elfin Eye" radio-advertising-belttler which, when the serious-minded announcer shovels out the manure, slyly winks at the radio audience.

A ROSE, with aphids clinging thereon, to the McNameene bows to Bowes and the States' bows to Bowes and the Cities' bows to Bowes and Bowes' bows to Bowes which, if stretched end to end would reach back to Bowes anyhow, but compressed somewhat, as they are, manage to eat up a lot of time that might well be devoted to amateurs.

◆
 BEING NEUTRAL OF mind and peaceful of nature—in fact, a complete washout—we find our sleep disturbed by the ramifications of the dark influences that play over man like the rays of a searchlight (some metaphor, eh boss?). Who would imagine, for instance, that the politics behind the Ethiopian imbroglio would so influence a man long identified with radio that he would actually indicate in print his partiality to the Colonizing Force. Yes, sir, as difficult as it is to believe, the Editor of "Radio Today" distinctly referred to our very own Federal Communications Commission as the "Commish." If you don't believe us, cast your eyes on page 8 of the September issue. (*Free Adv.*)

◆
 AND NOW THAT we have your attention on *influences*, let us hasten to record the effects of the Present Administration on the brain cells of our good friend who put to bed the new Wholesale Radio Company's 1936 Catalogue.

Torn between radio and politics, no doubt, our good friend referred with great gusto to the excellent features of the "new deal" on the National HRO Receiver.

◆
 NOT TO BE STOPPED, we continue with a short newspaper item to which was appended a very appropriate observation. Here she be.

Sant Margherita, Italy—Marconi announces imminent perfection of experiments to halt airplanes, warships, and autos with ultra short waves.—*Pittsburgh Press*.

Sounds like the powerful N R ray.—*The New Yorker*.

Which merely goes to show that at least half the nation is preoccupied . . . and it's all because of the dark influences playing upon man like the rays of a searchlight.

A TEA ROSE to "Babs" at W6CIN, Arcadia, California, whose gentle, well modulated voice puts stars in our eyes.

About seven in the evening we turn to the 20-meter band to learn how her crop of lemons is coming along. The last we heard, it's going to be a good one. Hope so. She needs lots of lemons to pay for the juice. No juice, no Babs; no stars in our eyes.

◆
 WE ARE CONCERNED over the omission of an emphatic denouncement from the list of amateur abbreviations. These boys have their 73's and their CUL's and their FB, OM's, and quite a collection of other hyphenated articulations, but nothing that expresses, even in the mildest form, the disgust they must—and we do—feel at times.

With a view to adhering rigidly to the abbreviated forms used by the Ham fraternity, and subject to the approval of the F.C.C., we offer two simple letters, to be appropriately spaced when used, which, we believe, will satisfy the soul of many a harassed amateur if they be sufficiently drawn out. The letters are P—U.

◆
 WE ARE ALL for instituting a course of training for the 'phone-amateurs-who-have-nothing-to-say . . . and say it. As a matter of fact, we are all hopped up over the idea, and have as an object the training of at least one amateur in each district who will read us a story at that critical moment between consciousness and peaceful slumber. Then we can go to bed with the headphones on—a secret desire we have had for some time, like the desire some people have to sleep in the raw.

◆
 PRIOR TO OUR attack of corns, we had slight difficulty with the 6E5 tuning indicator in our RCA set. Being somewhat of a fiddler, we pulled the chassis and learned upon close investigation what appeared to be an oversight on the part of one of the RCA girls—that is, a missing connection.

After adding the wire our reason told us should be present, we replaced the chassis and idly tuned the set to LQE—a way down thar in the Argentine. (This is a code baby, and all he sends is LQE and the frills that go with it.)

Happening to glance at the bare face of the 6E5, we saw what looked very much like a string of hot dogs that had been made without thought to uniformity.

Suddenly it dawned on us that we had made LQE's signals remain motionless. Yes, sir—there was that baby's call just as pretty as a picture. Black magic, you say? Not a bit of it . . . stroboscopy, just stroboscopy.

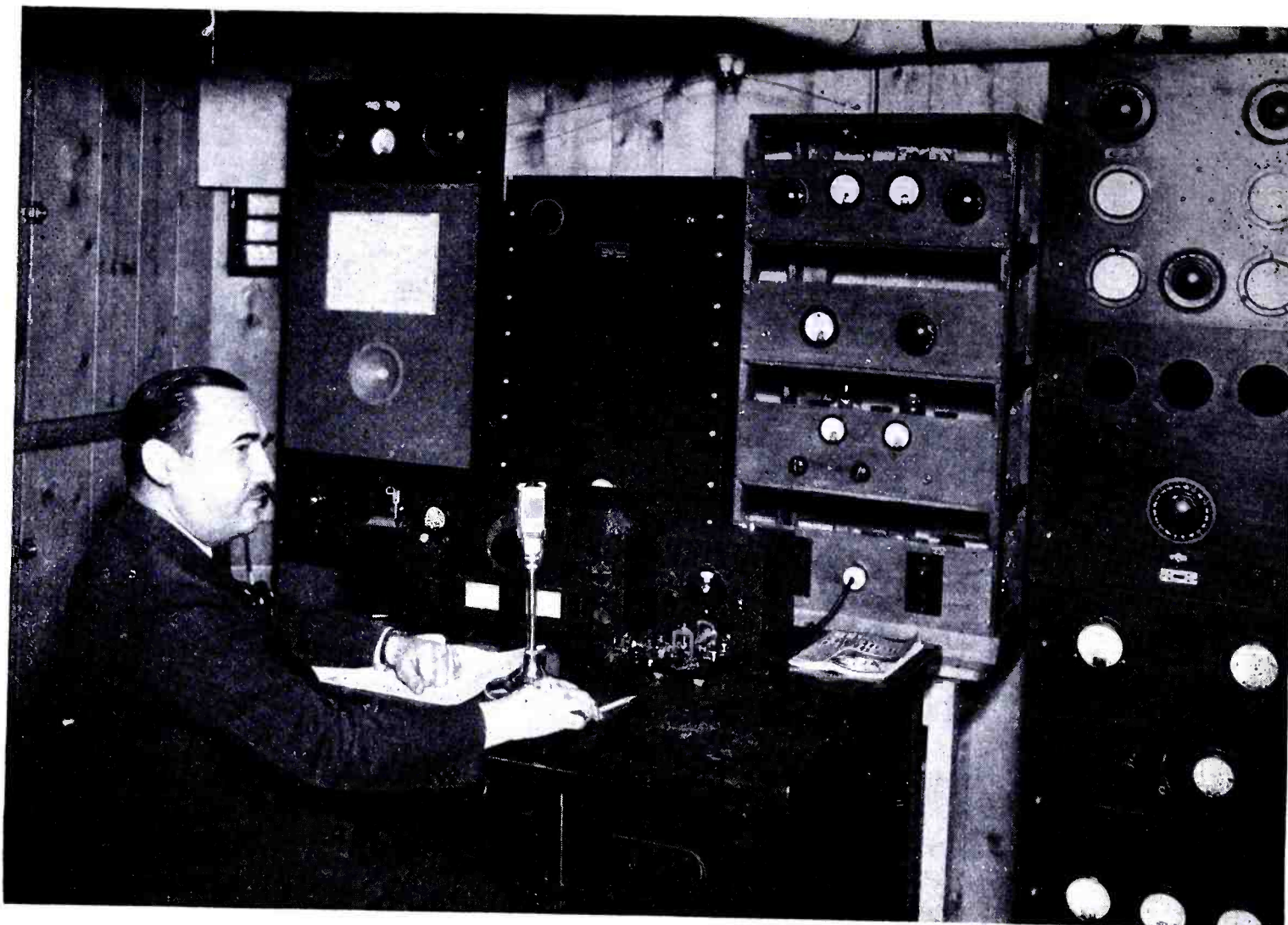

"Doc" Dunn—Amateur Station W2CLA

By S. P. McMINN
W2WD

FEW STATIONS are more complete, certainly none is more one-hundred percent simon-pure amateur, than is W2CLA, owned and operated by Major L. J. Dunn, Ex-Radio Aide to the Chief Signal Officer, U. S. Army, ex-director of the Hudson Division A.R.R.L. organizer and president of the pioneering Garden City Radio Club and bred-in-the-bone experimenter.

"Doc"—the appellation is due to the D.D.S. that follows his name in the phone book—dates his radio activities to the "way back when" days; way back when spark transformers melted the copper in the a-c feed lines; when sync gaps roared and whined; when Gernsbach's gadgets were the pride and joy of more than one budding ham; when coherers gave way to VTI's; when Telefunken tubes began to blossom and then to bloom; when 200 meters meant anything south of WJZ; and when J. H. Bunnell was the only place in New York you could buy a key.

Today the shack holds three complete transmitters and two receivers, not to mention portable equipment for transmitting and receiving and an assortment

of necessary testing instruments including a precision type Lampkin freq-meter.

Doc takes his radio seriously. It is a hobby that he rides hard but it doesn't ride him. Closely confining work makes relief vitally necessary. And he finds that relief in radio, among his radio friends numbered in thousands all over the U. S., in flying and in photography. These other things, though, are a side line. Radio is and always has been his favorite child.

He gets a great kick out of building things and making them work. He may not be entirely orthodox in his adoption of circuits and wiring diagrams, but the adaptation generally gets results, and that's what counts.

The Main Rig

Just now the transmitter that gets the greatest play is the 14-mc rig, which, except for a Collins speech amplifier and modulator, was designed and built in the

shack with the collaboration of Ed Ruth, W2GYL. The circuit is orthodox and in its present final form represents quite a period of experimentation and revision to bring effectiveness and efficiency to the topmost point. The r-f portion starts off with a '47 controlled by either of two crystals slightly different in frequency for quick QSY and selected by the flip of a switch. That tube, operating in the 3500-kc band, feeds an RK-15 doubler which in turn excites an RK-20 pentode that just about kicks the grids out of a pair of Western Electric 304A's in the final push-pull Class C stage. Running normally, the input is in the neighborhood of 240 watts.

The speech amplifier and modulator, as previously mentioned, is a Collins Model 7-C and has sufficient gain for the use of a crystal microphone without additional pre-amplification. The antenna is a Johnson "Q" fed through a Collins-type impedance-matching network and the signals draw a flock of QSL cards from all over Europe every time the rig is turned on.

Two separate power supplies are used and both are Thordarson throughout.

Each is rated at half a kilowatt. One supplies all the power, both B and C, for the r-f lineup, and the other puts the punch in the modulator which terminates in a pair of 203A's.

All control switches are brought to the operating table. In fact, operation of any and all equipment is within reach of the operator's left hand.

Second Transmitter

The second of the three transmitters is the 3500-kc band cw rig used mostly for AARS network communications and for rag chewing when the urge to pound brass over-rides the kick that comes from voice communication. Like the other, this rig starts off with a '47 similarly controlled from one of several crystals and feeding an 865 doubler which excites a pair of 845's in push-pull, with the final stage a pair of good, old 204's that are still going strong after years of hard service that should have entitled them to peace and quietness in the radio graveyard long ago.

Up to the 845's, juice for this rig comes from a Thordarson-powered rectifier rated at half a kilowatt. The plates of the 204's blush generously under the influence of a 1 kilowatt Esco motor-generator, which is completely enclosed and remotely controlled. The antenna is a half-wave Zepp fed through an impedance-matching network.

Ultra-Short-Wave Transmitter

The third transmitter—the one that supplies a great deal, if not most, of the fun—is a long-line 56-mc oscillator with a pair of 801's in it modulated by 46's in Class B. Local communication within a radius of 15 or 20 miles is carried on in this 5-meter band, where duplexing becomes so simple and so attractive. The antenna for that rig also is a Johnson "Q" located in the attic. Much experimentation has been done with beam arrays but space limitations have prevented the results that were hoped for.

Receiving Line-Up

In the receiving line-up a National HRO has the place of honor. The complement of coils permits coverage of the entire spectrum from 30 kc to the lower fringe of the broadcast band. The other receiver is the old reliable National SRR which has outlived any number of experiments to improve reception and has come to be looked upon as a standby. As "Doc" says, "It wears well."

Considerable experimental work has been done on frequencies as high as 112 mc and at one time recently a complete network of five or six stations operated in and around Garden City within a radius of about ten miles. At each station the equipment was similar, consisting of a single 800 in a long-line oscilla-

At the Gala Phonefest held at Thorne Donnelley's (W9PZ) Lake Bluff, Illinois estate, Arthur Lynch is shown addressing the thousand or more phone men who were in attendance. Thorne and his famous pipe are shown in the foreground. Incidentally, this photo was taken by James Millen, vice president and general manager of the National Company.



tor using modulation equipment switched over from the 56-mc rig. Receivers were built around the then new RCA Acorn tube. Excellent results were obtained locally but the small number of 112-mc stations in operation outside of the immediate neighborhood made return to the 56-mc band seem desirable.

Up In The Air

Doc holds a transport pilot's license and gets up into the air a couple of times a week. Frequently he takes one or another member of the Garden City Radio Club with him to carry 56-mc gear in his lap. A great deal of pioneer work has been done between planes and with ground stations at distances up to nearly a hundred miles.

As an organizer Doc's best work will be remembered for what he did for the Hudson Division of the A.R.R.L. But the birth of the Garden City Radio Club,

which has become so well known throughout the length and breadth of Long Island and beyond, will endear him more to those who work most closely with him. The club came into being as the result of thinly veiled threats to wipe the amateur fraternity right off the map of Long Island. Through a misunderstanding of the purposes and achievements of amateur radio the city fathers of Garden City decided after due deliberation that amateur radio was not a desirable thing for a residential community and that there just couldn't be any more of it. Under the leadership of Doctor Dunn, the Garden City Radio Club came into being. A technical committee was organized to offer help, guidance and cooperation with the city authorities and the whole matter was smoothed away to the complete satisfaction of both the amateurs and the graybeards.



The author, S. P. McMinn, pounding brass.

NEW BBC TRANSMITTERS

THE BBC has placed orders with Marconi's Wireless Telegraph Company, Ltd., and the Standard Telephones and Cables, Ltd., for two additional short-wave broadcasting transmitters for the BBC Empire Broadcasting Service. The construction of a new building at Daventry to house the transmitters, together with a greatly extended aerial system, will begin shortly.

THE REINARTZ S. W.

By H. A. TUMMONDS
W8BAH



THE AUTHOR

EVERY NOW AND then when activity on one or another of the ham bands seems to be stagnating, John Reinartz, WIQP, pops up with something so revolutionary and so simple as to make us all wonder why we had not thought of it ourselves.

At the Central Division Hamfest recently held at Cleveland, John told us of a new antenna which seems to have tremendous possibilities. It is more than ordinarily useful in locations where other types of directive antennas are out of the question because of their size. A beam array such as James Millen and Ross Hull have been using in connection with their extraordinary work on five meters between Malden and Hartford would be an inconvenient device to attempt to at-

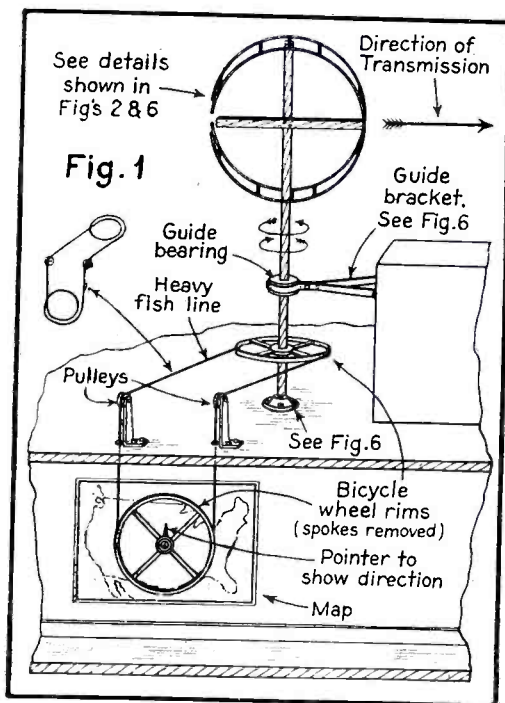

Sketch of a complete Rotary Beam Aerial installation.

IT happens that your Editor attended the Cleveland Convention when Reinartz told about the performance of the antenna, which is so well described by Harry A. Tummonds in the accompanying article.

Later, while attending the Gala Phonofest at W9PZ's Chicago station, he ran into Floyd Miers, W8LN, from Buffalo. The latter had also heard Reinartz describe his antenna and made one up and put it to use. He was most enthusiastic about its performance.

In order to determine the characteristics of this new idea, we arranged to have several of them used in the second district and the results have been remarkable.

John Reinartz claims a gain of 8 for this type of antenna, so that a 40-watt transmitter which would normally deliver about 20 watts to the antenna could be considered to have 160 watts in the antenna in the particular direction in which it is aimed.

We suggest that this antenna, and the long lines oscillator arrangement described in this issue, as being just about ideal for five-meter operation.

A Reinartz Beam Aerial for 2½-meter operation would be less than 17 inches in diameter. We hope to have more to say about it soon.

tach to the top of a flag pole. There would be no trouble in using the antenna we are about to describe, even in such a location.

Directivity

In addition to providing an antenna of very small dimensions, this new scheme concentrates a large portion of the transmitted wave in a desired direction. The same holds true for the antenna when it is being used for reception. Desired stations, therefore, are received with very much greater signal strength, and interference from stations, if from one side or behind the antenna, is reduced materially.

Where a station is to be operated on a fixed frequency, the antenna can be designed for that particular frequency only and it is likely that greater efficiency may be noticed than in the present design. However, for ham operation in the 56-60 megacycle band, Reinartz recommends that the antenna be designed for optimum performance in the middle of the band and that permits tuning up and down from the 58-megacycle position, without serious losses.

Materials Required

The materials necessary for making the antenna, include:

Two 8-foot lengths of soft drawn copper tubing, 3/8 inch in diameter.

One wooden pole, as high as it is desired to extend the antenna above the roof.

One cross arm, approximately 2½ feet long. A cross section of 2 inches x 2 inches is plenty for these sticks.

Eight 6 inch wooden dowels, or square separators, are used to keep the pipes apart and the manner in which they

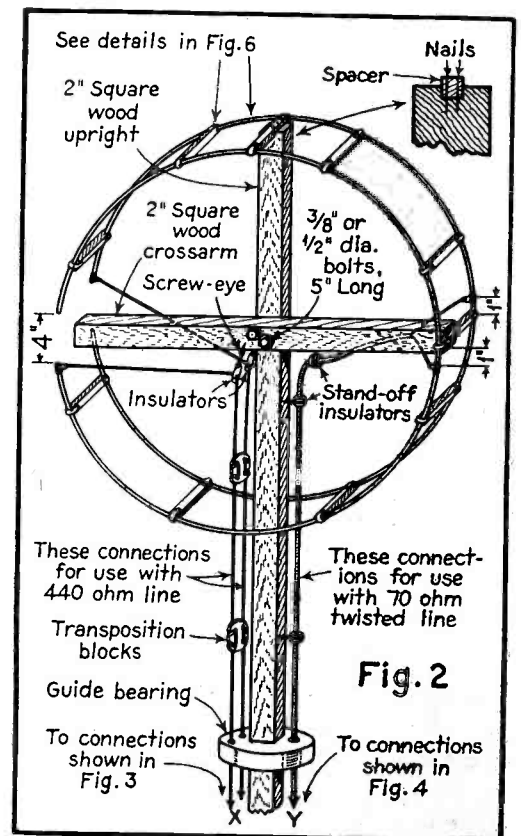

Details of the aerial proper, and how the transmission lines are connected.

are employed is shown in the accompanying drawings. These dowels should be immersed in paraffin, if the antenna is to be out in the open.

Soft drawn copper tubing is recommended for this type of antenna because it is so easy to manipulate and it will retain the position to which it is set. Hard drawn tubing is a bit more difficult to use because it is likely to spring out of shape. Care must be exercised in manipulating the soft drawn tubing to prevent the outside surface becoming dented. The ultimate form of the antenna is illustrated

ROTARY BEAM AERIAL

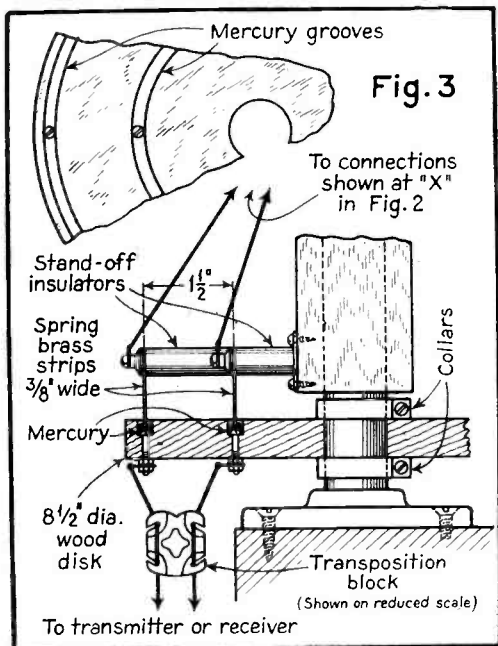

How connections are made between the transmission line and aerial.

in Fig. 1 and it will be seen that the 8-foot lengths have been bent into the form of a circle. This circle has an open mouth of 4 inches.

Forming the Tubing

The easiest way to bend the tubing is to describe a circle, having a 33-inch diameter, on the floor or wall. Then nails may be placed around this circle, about 4 inches apart. The tubing is then bent around these nails. Both pieces of tubing are treated in this same fashion. The two are then joined to the wooden dowels by any convenient method, such as a metal strip wrapped around the tubing, as shown in the accompanying drawings. Where maple dowels are not available,

sticks made of almost any kind of wood, 1/2-inch square, will serve the purpose very satisfactorily, particularly if the outside end is slotted so as to form a fit for the tubing itself. Separators of this kind are very easily made from a long length of 1/2-inch square wood with holes made by a 3/8 inch bit, having their centers 6 inches apart. This long strip is then cut across the holes as shown.

The mast and cross arm are joined by any convenient method and the use of two 4 1/2-inch machine bolts, as illustrated, has been found to work very well.

Next the two pieces of tubing are attached to the separators and the entire assembly is then placed on the mast and cross arm.

Assembly Details

The details for assembling the mast and cross arm are a matter of convenience and personal preference. It may, for instance, be simpler to extend the top of the mast above the loop and use a thirty-six inch cross arm. In this case, the separators may be fastened to the surface of the mast and cross arm. It is suggested that the separators be drilled, before the wood screws are put in place, to prevent splitting. This form of construction makes the slotting of the mast and crossarm unnecessary.

There is less tendency to split wood and the screws may be driven home with greater ease, if the screws are pushed into a cake of common soap before they are used. The soap acts as a lubricant.

Transmission Lines

Almost any form of transmission line can be used between this antenna and the

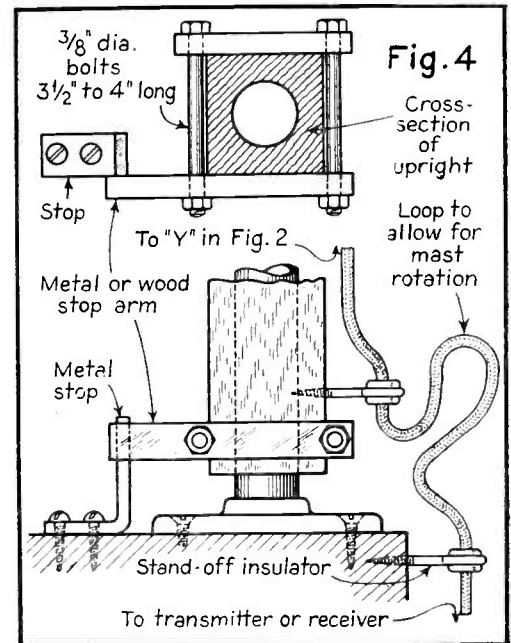

How the base of the aerial is made. Note loop in transmission line.

output circuit of the transmitter. If a 440-ohm line, such as is very readily made by the use of two stranded conductors and transposition blocks—the wires are not transposed in this instance—the connections are made as shown, at the left in Fig. 2. If a low-impedance line, such as a twisted pair, is to be employed, the connections are made as shown at the right in Fig. 2. A very simple method of making the connections between the line and the tubing is to utilize the large size National grid clips and when the correct position on the tubing has been found, these clips may be soldered directly to the tubing itself.

The clips should be put on the tubes, before assembly, if a low-impedance line is employed. It will be seen that the



Winding the loops . . .



The loops are fastened . . .

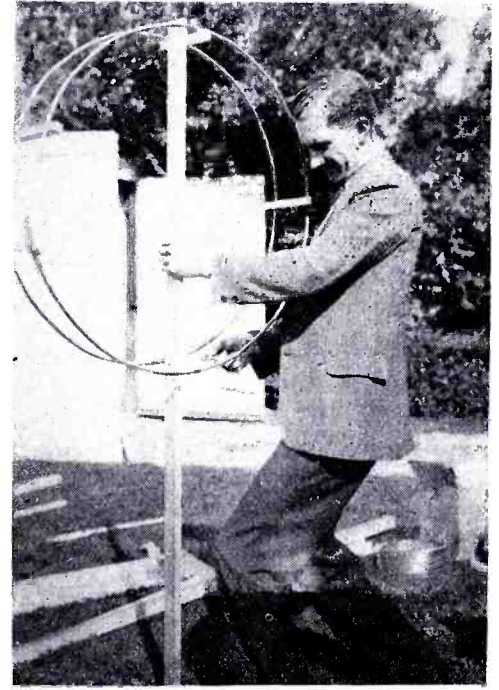

The frame is added.

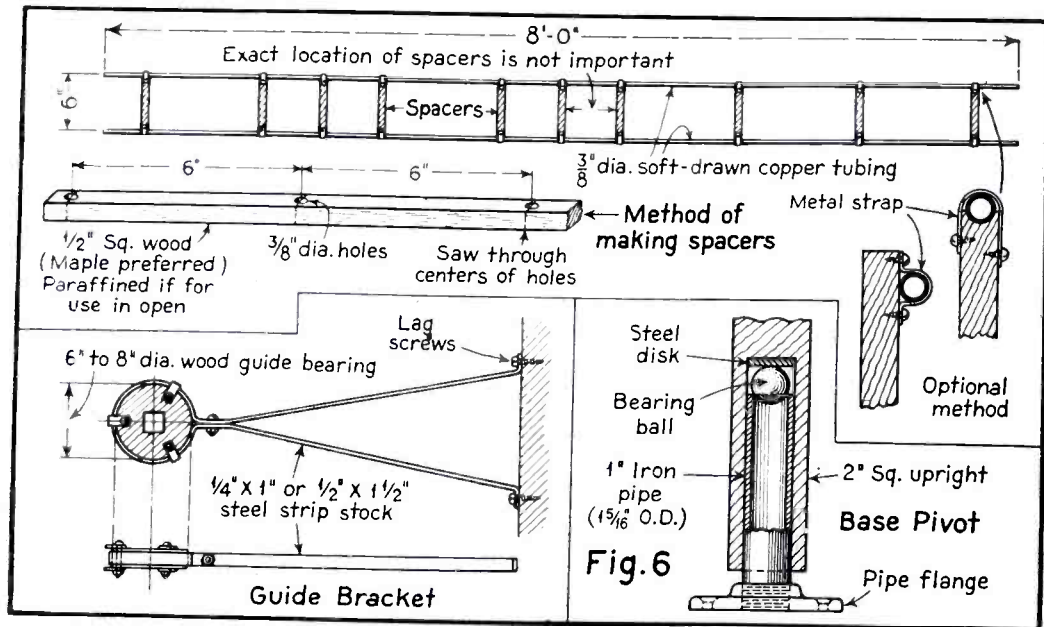

Details of the spacers, guide bracket and base pivot.

transmission line can be run along the cross arm to the mast and then down the mast to any convenient place above the station, where the twisted pair type of line is employed. Precautions for preventing the line becoming twisted are much easier provided than would be the case where the open line is employed.

The simplest form of a rotary antenna may be obtained by drilling a hole in the bottom of the mast and placing the mast itself over a metal pivot. A few suggestions for mounting the mast and supporting it against the side of the building, as well as a simple means for rotation on a pivot, are all covered in the sketches.

"Battling the Ionosphere With Kilowatts"

A NEW APPROACH to the transmission of short-wave radiotelegraph signals over long distances will be tried by RCA this Fall on the completion of a new 200-kilowatt short-wave transmitter now under construction at the company's station at Rocky Point, Long Island.

By means of this tremendous short-wave power, which is 5 to 10 times the intensity usually employed in international communication, it is proposed to "battle the ionosphere with kilowatts" and over-ride certain natural obstacles which to date have limited the signal strength under abnormal conditions.

The Ionosphere

The ionosphere is an electrified region at the earth's outer atmosphere. Short-wave radio signals are reflected back and forth between this region and the earth in their passage around the globe. There are cycles in the daily condition of the ionosphere which make it necessary to use several wavelengths for long-distance radio communication. There are also times of magnetic disturbances, when the turbulent condition of the ionosphere causes absorption and dispersion of the radio signals and consequently re-

Non-Twisting Feeders

Where the high-impedance, spaced line is used, the difficulty of having the line twisted is obviated by the arrangement shown in Fig. 3. In this case, the transmission line which runs parallel to the mast is terminated at two stand-off insulators. These insulators support two fingers which extend into the mercury which is placed in grooves, in a disc, made from a piece of paraffin-treated wood. A hood can be placed above the mercury container, to prevent dust or water accumulating. By this arrangement it will be seen that the antenna can be rotated

duced signal strength at the receiver. It is then that even highly concentrated radio beams become least effective.

What the engineers expect to determine by means of the new 200-kilowatt transmitter is whether the hours of usefulness of one or more of the wavebands used in long-range communication may not be lengthened and the effects of magnetic storms minimized by the use of increased power.

To Transmit on 28 Meters

The new transmitter will be operated at first only on one wavelength, in the neighborhood of 28 meters. This wave has been selected as the trial one which promises the greatest general serviceability. It is expected that when radio signals from this transmitter are hurled against the ionosphere the greater power will cause them to be reflected back even during less favorable hours of operation for that particular wavelength. Present-day commercial radio practice has been brought to a high degree of reliability by directive transmission and the diversity system of reception. This new step by RCA looks toward further conquest of the ether by enabling transmission through severely disturbed periods.

continuously at will, without having any trouble with the feeders.

Where the twisted pair transmission line is employed, this device is unnecessary, but a stop should be provided which will permit full 360 degree rotation of the antenna, but will prevent the transmission line becoming twisted more than a single turn, as shown in Fig. 4.

Direction of Transmission

The direction of transmission with both high and low impedance lines is shown in Fig. 1. An approximate idea of the distribution for such an antenna, when it is in any given position, is shown in Fig. 5.

For all-around five meter activity, it would seem as though Reinartz has really provided something very satisfactory for us, in this antenna system.

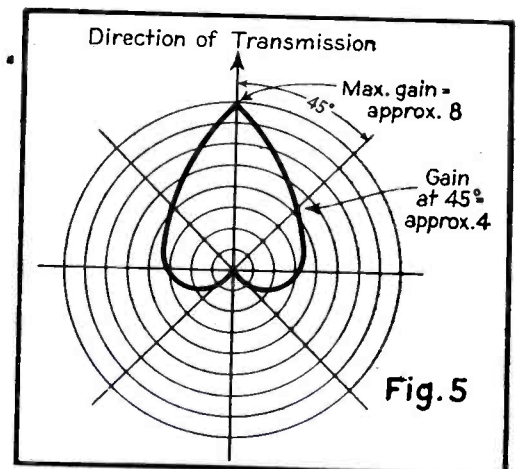

Showing direction of transmission and distribution pattern of Rotary Beam Aerial.

In a word, it is proposed to meet nature in her occasional turbulent moods with the sheer brute force of man-made radio power. And apparatus more powerful than any ever built for this service is being made ready to harness kilowatts to the task.

The new transmitter will be immediately available on completion for commercial use in multiplex radiotelegraph transmission and facsimile transmission. It may ultimately be adapted to the transmission of addressed programs of voice and music to foreign countries.

EARLY TO RISE, LATE TO BED IF YOU WANT CHINA

"AMERICANS WHO want to hear broadcasts from China must get up early or stay up late. The waves of ZBW, Hong Kong, flash across their part of the world in the 'dead of the night.' Recently, at 4:15 A. M., in New York, an announcer on the 8,750-kilocycle channel disclosed that ZBW was relaying a program from Daventry, England, but he did not say whether the broadcast was a direct relay or from a recording." (N. Y. Times).

Nineteen tubes — battleship construction—high fidelity—sixty watts audio peak—control flexibility—9.4 to 568 meters and 732 to 2150 meters—high r-f gain—“deep down” automatic volume control—double speakers . . . The Masterpiece IV. Here it is.

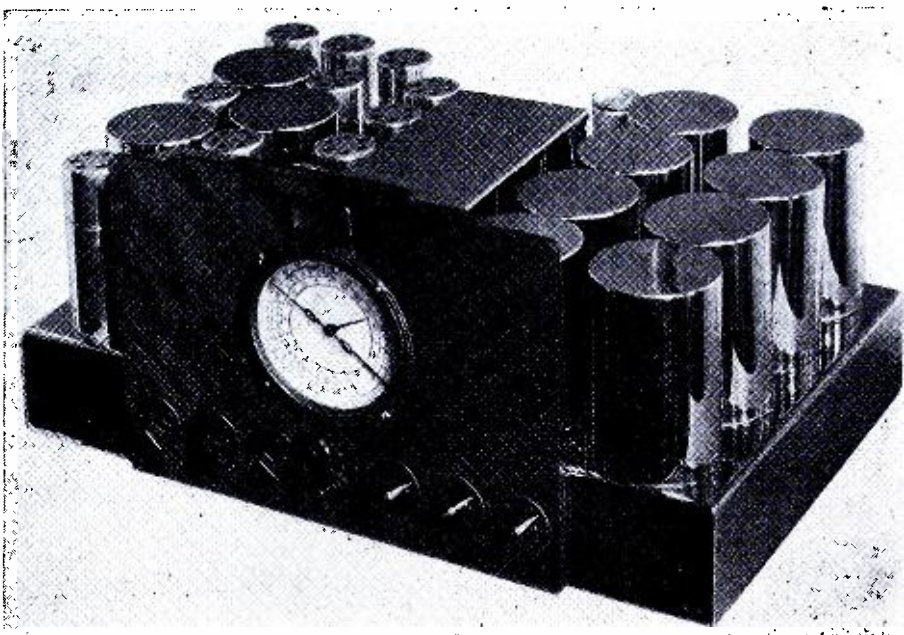

THE MASTERPIECE IV

By **McMURDO SILVER**

IN THE DESIGN of the Masterpiece IV as much careful and exacting attention has been devoted to mechanical perfection as to electrical perfection. Much of this is reflected in the cleanness of the units as a whole, and still more by the ship-shape mechanical work visible beneath the chassis themselves, but much more indeed remains unseen and unheard forever, as it should.

In general, the technique of battleship building has been rigorously followed—rivets used where possible, lock washers, screws and nuts, every single component solidly and firmly fastened to its supports on the chassis—construction capable of withstanding both electrically and mechanically the hardest sort of treatment in shipment and in use, be it in the arctic or in the tropics.

Circuit

There are no trick secrets in the design of the Masterpiece IV, simply tried and proved engineering experience carried out to the *nth* degree. Hence, no hesitation is felt in revealing the circuit diagram, and in describing as far as space permits the salient points.

This circuit shows two 6D6 r-f pentodes used in two tuned r-f amplifier stages preceding the 6D6 first detector, to the suppressor grid of which is connected the 76 signal-frequency oscillator. These four circuits cover a total of five tuning ranges with a single four-gang, 365-mmfd condenser by means of five sets of four separate and distinct tuning inductances each, selected by eight five-position, wave-change switches operated

by a single shaft and knob. All r-f circuits are trimmed and aligned by air dielectric, isolantite insulated condensers.

Following the first detector are the total of three dual air-tuned, 465-kc intermediate-frequency amplifier stages using 6D6 r-f pentodes, with the two-position, two-section switch which cuts out the first two stages for high-fidelity reception, or cuts them in for ultra-selective distance reception.

AVC System

Coupled to the third i-f amplifier is the r-f pentode section of the 6B7 used to provide additional i-f amplification for the avc system, which is in turn coupled to one diode portion of the same tube to develop rectified voltage for automatic volume control, which applied to the control grids of both r-f stages, first detector and two of three r-f stages, provides quintuple automatic volume control. This amplified and rectified avc voltage is further amplified by the triode elements of the 85 tube, for application to the visual tuning meter.

Also coupled, inductively, to the last i-f transformer secondary, is the 76 audio beat oscillator for short-wave station location and cw code reception. This secondary of the third i-f transformer feeds the two diodes of the 85 tube connected in parallel, which functions as second detector. Through the duo-diode i-f filter and load resistor the new rectified audio signal voltage is resistance coupled to the 76 first audio voltage amplifier.

In the plate circuit of this tube is the

headphone jack, and the audio compensating circuits for the dual tone control system. These circuits involve a Clough system tuned push-pull audio transformer for low-frequency boost, the degree of which boost is controlled by varying the resistor (Bass Tone Control) shunting the transformer primary, and a high-frequency tuned circuit and load resistor in the series feed circuit to the 76 plate. The high-frequency compensation rheostat-condenser (Treble Tone Control) shunts the audio transformer secondary, which feeds through a twisted pair in the power cable to the grid of the push-pull Class A triode-connected 42's in the second audio, or power-driver stage, in the amplifier. These in turn couple through the double push-pull transformer on the amplifier to the grids of the four fixed-bias Class A Prime (AB) triode-connected 42's in the power output stage.

Splitting Filter

At this point the splitting filter isolating bass and treble frequencies to the bass and tweeter speakers comes in. It consists of a large output transformer coupling the output stage to the voice coil of the bass speaker, so wound that its distributed capacity is high and provides effective isolation against high frequencies for the bass speaker. Its primary serves as the plate load for the output stage, and across it is connected the series circuit of condenser and primary of the tweeter speaker coupling transformer. This small series condenser, coupled with the carefully worked out im-

pedance relations, effectively and automatically removes the tweeter from circuit on low frequencies but brings it into play from 3,000 cycles up.

Power Supply

The power supply involves a very large and heavy power transformer operating from any 105- to 125-volt, 50- to 60-cycle power line (or through available reducing transformer, from 210- to 250-volt lines) which has three secondaries. One secondary supplies 6.3 volts at 7.5 amperes to the tubes of the tuner and amplifier. A second lights the 5Z3 rectifier filaments, and the third provides high voltage to the 5Z3 plates for rectification and filtration into the final plate and grid voltages for the receiver. This transformer is provided with an electrostatic shield between primary and secondaries to drain off power-line noise and prevent it getting into the receiver circuits.

Two 5Z3 full-wave rectifier tubes are used, connected in parallel, to supply the 250 milliamperes at 388 volts required to operate tuner and amplifier. Thus, each tube is operated at just half its rating, to insure long and trouble-free life, although one would do the work, but with no safety factor whatsoever.

The filter system is choke input, employing one low-resistance choke, and the tweeter and bass speaker fields. The circuit diagram shows a series-pair input condenser, which, however, being of only .25-mfd. capacity (800-volt rating) to eliminate mechanical vibration in the input choke, is too small to function as a starting condenser, so that though diagrammed otherwise, the filter system is actually choke input—absolutely necessary for the well-nigh perfect voltage regulation necessary to powerful audio amplifiers.

Automatic Voltage Regulation

Following this choke is 16-mfd of 475-volt automatically self-healing wet

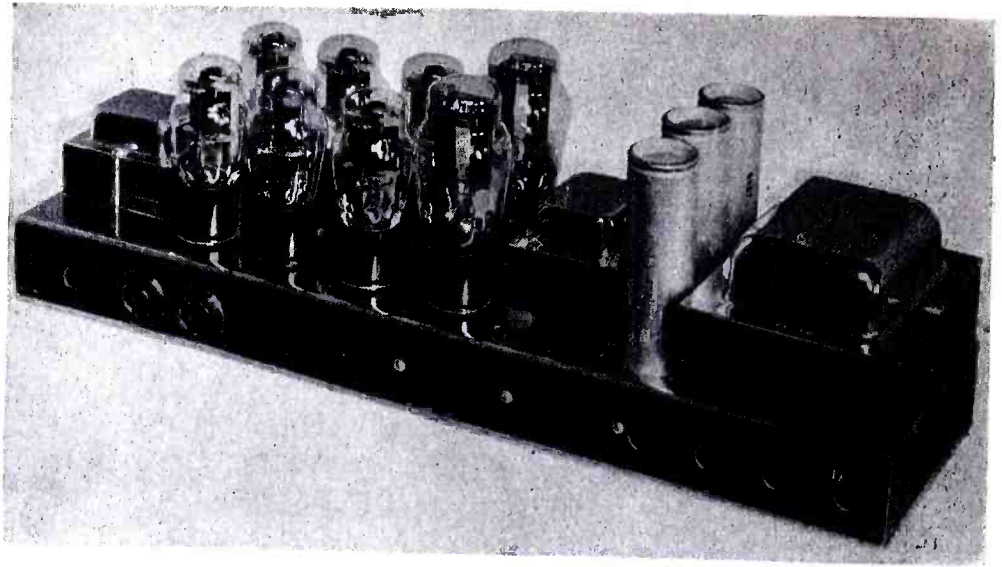

The husky "power" chassis, containing the double-rectifier power-supply unit with special filter system, and the 35-watt Class AB amplifier which drives the dual dynamic speakers shown below.

electrolytic capacity; then 12-mfd of self-regulating filter capacity. After this is the third section of the filter, the bass speaker field obtaining 12 watts excitation, followed by 18-mfd of self-regulating capacity. These two self-regulating and total of three self-healing electrolytic condensers are just another fine point of the design. They temporarily absorb the voltage developed as a result of the quick heating of the 5Z3 rectifier tubes, which develop full voltage before the heater tubes are warmed up enough to absorb it as they do in operation. During this time interval of twenty to thirty seconds, the second two filter condensers act as absorbing resistors, but as soon as operating voltage reaches normal, they cease to draw current and resume their function of pure filter capacity. Thus by this new system, all strain on circuit components during "warming-up" is completely eliminated, while filter condensers being automatically self-healing, remove all possibility of breakdown in service.

Fixed-Bias Output Stage

Substantially fixed bias for the 35-watt Class A Prime output stage is obtained through the voltage drop across a resistor in the negative power supply lead, through which the entire current for the receiver, amplifier and bleeder network is drawn. During peak signal conditions the maximum voltage variation across this resistor due to changing current through it is such a small percentage of the total current flowing through it (and bias voltage developed across it) that the bias voltage variation is negligible, which permits of obtaining 35 to 60 watts of undistorted power output from the power output stage.

Gain Ratios and Inherent Noise

In the perfect radio receiver the final limit of sensitivity should be, but seldom or never is, the limit set only by thermal agitation in the input circuit—the constant movement of the electrons making up a supposedly solid copper wire in the first tuning inductance. The attainment of this connection is almost impossible to superheterodyne receivers because of noise introduced in the first detector-oscillator frequency conversion function. Quantitatively this noise is about 4.0 microvolts for pentagrid converters (2A7—6A7 tubes); about 2.0 microvolts for ordinary separate detector-oscillator tube combinations, and about 1.0 microvolt for suppressor-grid injected oscillator-detector circuits.

From this it is obvious that the inherent circuit noise will be overwhelmingly great in relation to received signal when any attempt is made to receive signals in the range of $\frac{1}{2}$ to 4 microvolts absolute input to the receiver. Equally obvious, any attempt to reach such usable sensitivities by increasing i-f amplification cannot remedy this condition, and will, in fact, only add i-f amplifier noise to already ruinous oscillator-detector

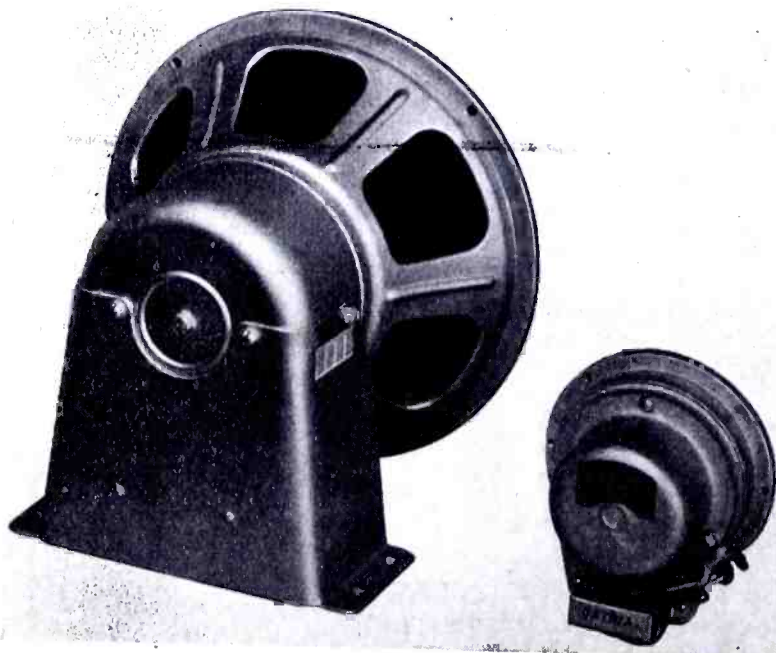

"High-Low"—The giant and the midget: one for bass and one for treble. Together they reproduce a wide range of audio frequency tones.

noise in any attempt to receive very weak signals.

The answer to this problem is the use of plenty of r-f amplification before the first detector in order that the received signal presented to the first detector-oscillator shall be so strong as to swamp out detector-oscillator noise, and to so proportion r-f, i-f and a-f amplification in the whole receiver that no noise will be introduced into its output except that due to thermal agitation in its input circuit, if the receiver be sensitive enough to show this up in its output circuit.

Thus it is seen that the ideal superheterodyne receiver will have high r-f gain, the quietest possible first detector-oscillator system, relatively low i-f gain and relatively high a-f gain, since a-f gain is easy to obtain quietly and in addition prevents overloading of the second detector, provides good AVC action, and plenty of amplification for phonograph or microphone operation when it is desired.

These requirements are met in the Masterpiece IV.

Temperature Isolation

The best electrical design insuring frequency stability and permanent accuracy of dial calibration and other characteristics can be easily ruined by normal tube

and bleeder resistor heating affecting circuit components, particularly the oscillator circuit. The answer is double barrelled—circuit components substantially independent of heating over ordinary ranges, and the elimination of even such normal heating from delicate circuits.

This means that in the ideal receiver all r-f coils should be in individual shields on top of the chassis for good ventilation, and well away from heated tubes or bleeder resistors, with temperature shielding used in addition to air-dielectric trimmers instead of the usual unstable compression mica trimmers in which capacity change is a function of less than the ten-thousandth of an inch plate movement easily caused by even daily temperature changes, not to mention tube and resistor heating, on already strained plates.

In the Masterpiece IV all r-f circuits are located at the right end of the tuner, well away from all tubes, in individual shields having ample ventilation and of such size as to provide high inductance efficiency. Additional temperature isolation shielding is below the chassis which, coupled with ample ventilation, ample separation from heated tubes and bleeder resistors, stable anti-humidity impregnated inductances on heavy micarta in-

ulating forms, and air-trimmer condensers, gives a permanency and stability of dial calibration and overall performance difficult to equal.

I-F Amplifier

As has been pointed out previously, a receiver boasting high i-f gain is to be avoided because high i-f gain is unavoidably synonymous with high inherent circuit noise. In the Masterpiece IV almost the entire i-f gain is obtained in the one stage used for high-fidelity reception. When the additional two i-f stages all cut in, they provide a total gain of only twelve times, but contribute greatly to selectivity.

This is the true function of the i-f amplifier of any superheterodyne, although only now being realized by a few designers—to provide needed selectivity, not noise-producing and hence undesirable excessive amplification. No i-f amplifier of any superheterodyne should ever show more than 20 microvolts sensitivity, and preferably not less than 60 microvolts, if the receiver lays any claim to high sensitivity not vitiated by excessive inherent noise.

The four i-f transformers of the Masterpiece IV each consists of two high-Q, (Turn to page 96)

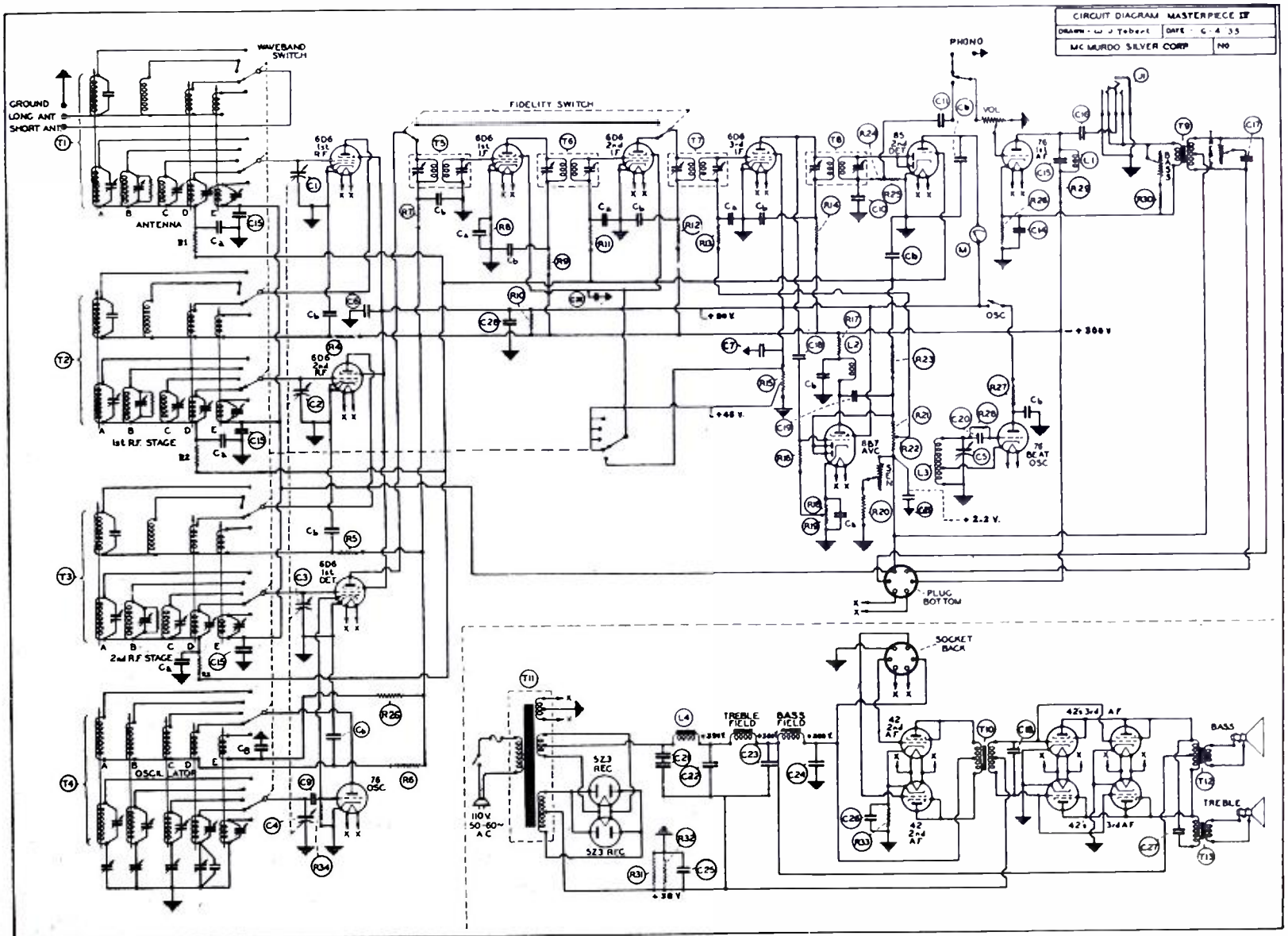

The circuit diagram of The Masterpiece IV—worth a thousand words.

A DOCTOR— AN AMATEUR

Dr. Burton T. Simpson— Station W8CPC

By FLOYD MIERS, W8LN—Buffalo

DR. BURTON T. SIMPSON, W8CPC, is one of the most enthusiastic radio amateurs in the United States. He entered the amateur ranks in 1926 with a modest Hartley transmitter and since that time has kept pace with the advancement of the art. He was one of the first amateurs in his territory to successfully put a crystal-controlled transmitter on the air and was the first amateur in Western New York to obtain an extra first class amateur ticket. At the present time Dr. Simpson has one of the outstanding amateur stations of the country, a photograph of which is shown on this page.

The "Shack"

The "shack" is located in a large bedroom on the second floor of his home with a good sized adjoining closet for a

work shop. There are two transmitters with identical circuits, viz., 802 oscillator, 210 doubler, 210 buffer, a pair of 830's for amplifier, modulated Class C by a pair of 845's. The final linear amplifier consists of four 852's push-pull parallel. One transmitter, using a 160-meter xtal, is used for 40-meter cw and 8-meter fone, and the other, using a 40-meter xtal, is used for 20-meter cw and 20-meter fone. Both transmitters have one kilowatt input on cw and a half-kilowatt on fone. The antenna is a split Hertz, 33-foot flat-top on each side of the center, fed with 45-foot feeders and 40 feet off ground. This type of antenna is used because it works well on the three bands mentioned and also because of limitation of space in the back yard.

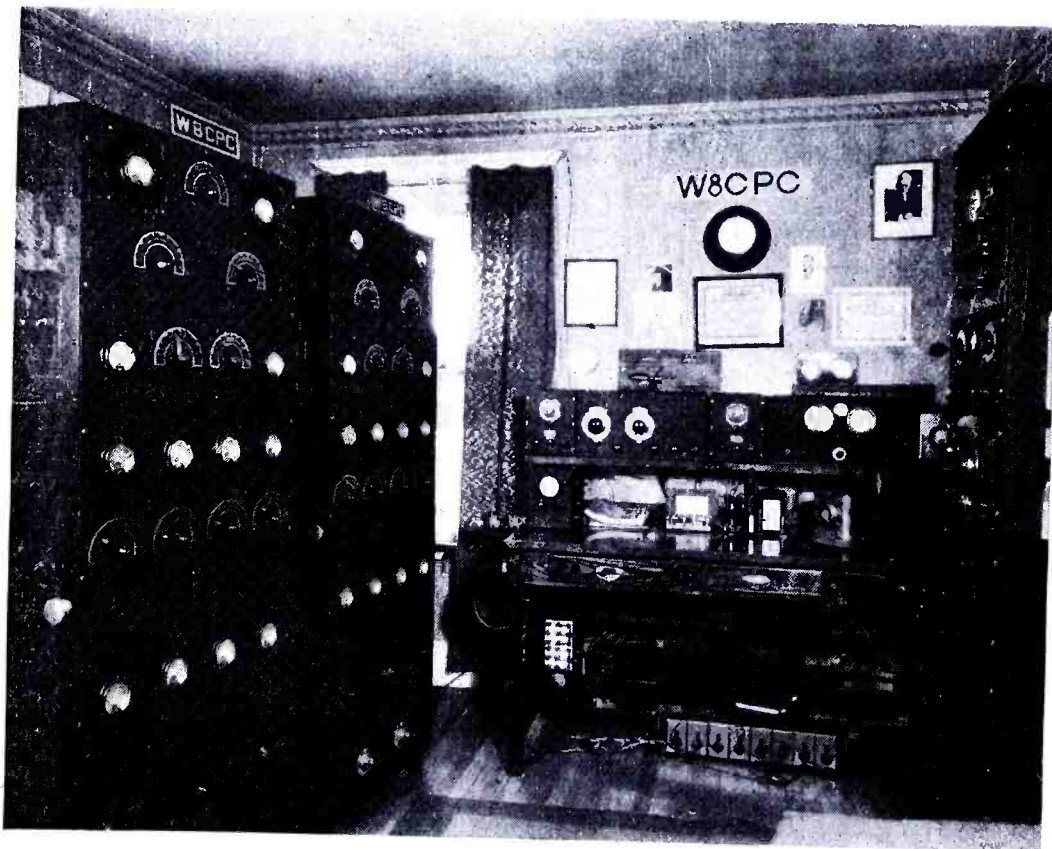

Station W8CPC—Transmitters and receivers galore! One transmitter is used on the 20-meter band only. The other is used on 40 and 160.



Dr. SIMPSON

The Receivers

The receivers used at W8CPC are: a seven-tube home built superheterodyne with a Peak pre-selector, an RME-9 and an HRO. There are three oscillographs: a National, connected with transmitters to check the outgoing signals; an RCA connected with the receiver to check the incoming signals; and a Kaltman and Romander, connected with the audio system. The rack-and-panel job contains a 100-kc xtal bar oscillator in connection with a frequency meter, also the audio amplifier and a mixer system. The mike used at present is a Turner xtal.

In the work shop the five-meter receivers and transmitter are located. The doctor is an enthusiast on the ultra-high-frequencies and is president of the Omega Tau Five Meter Club.

Amateur Radio As Hobby

When the doctor is asked what he thinks of amateur radio as a hobby he becomes serious and will say that it is the finest hobby in existence, but even more than that—it is almost a liberal education.

Dr. Simpson is at present intensely interested in the formation of fone organizations. He has been partially instrumental in the organization of associations in the following ARRL Divisions: Atlantic, Canadian, New England, West Gulf, Delta, Midwest, Central and Dakota, and is at present the president of the Atlantic Division Radiofone Association. When asked the object of forming fone organizations he will say, "To preserve amateur radio."

With the advent of a great group of short-wave listeners, the conduct of the amateur using radiofone is being sharply scrutinized. Ungentlemanly transmissions will not be tolerated. In the past the amateurs have policed themselves.

More recently the government has made some stringent regulations and has established monitoring stations to check and penalize the amateurs who commit any infraction of the rules.

In the preamble of the constitution of every fone organization may be found the following statement, "We, radio amateurs interested in radiotelephone, being desirous of upholding a high standard of this branch of the radio art, do establish this constitution." There is also a code of ethics by which every member agrees to abide. If every amateur would join the fone association and live up to its ideals there would be little to fear about losing our status and much to be gained.

Dr. Simpson not only likes to contact amateurs over the air, but enjoys meeting them personally. Therefore, he is a confirmed attender of hamfests and conventions. To date this year he has attended more than twenty of these functions.

Dr. Simpson's Activities

Perhaps you would like to know something of the doctor's activities aside from amateur radio. Dr. Simpson is the Director of the New York State Institute for the Study of Malignant Diseases. In

plain words, he is the head of one of the largest institutions in the world for the study and treatment of cancer. The Institute has all the modern facilities for research and the largest amount of radium of any single institution in the world. Experiments are being carried on with ultra-high frequencies in the treatment of cancer, so you see that the doctor's knowledge of amateur radio has been of help in his own work.

Dr. Simpson does not confine his attendance to radio conventions but has frequently to attend medical and scientific conventions. He has attended and read papers at several international congresses in Europe and is known throughout the world as an authority on cancer. While the doctor does not practice medicine in Buffalo, he acts as consulting physician to a host of amateurs throughout the United States and Canada, for when an amateur sees in the call book that he is working an M. D., the amateur immediately takes the opportunity to get a little free medical advice! If you should contact W8CPC on the air, ask him to relate some of his amusing experiences along these lines.

The doctor has a favorite remark which he takes every opportunity to express, viz., "There is no such animal as a 'cw' man or 'fone' man—we are all

AMATEURS." If one gets his kick out of cw that's his business; likewise for fone. However, the doctor believes that the fully rounded amateur should take advantage of all the art offers and operate both fone and cw. Another belief the doctor has is that every amateur should be a member of the ARRL. Were it not for this organization there would be no amateur radio today. It is conceded that the FCC recognizes the League as the spokesman for the amateur. As members of the League we can therefore cast our vote and have something to do with the recommendations for the best interest of amateur radio.

Frequency Allocations

The doctor is of the opinion that we are more liable to lose some of our frequencies than we are to gain any. The television group is after our 56-megacycle allocation, and if the broadcast listeners become antagonistic, we may lose more. The Government will not tolerate a nuisance and it therefore behooves every amateur to be meticulous in his operating practices. There has been some dissension in the amateur ranks, but this is a mistake and we should stand united if we wish to keep the finest hobby in the world.

A GOOD STORY

ONE OF THE best after-dinner speakers and story tellers we have heard in many moons was brought to our attention when we were among the "stuffed shirts" at the banquet which terminated the Central Division A.R.R.L. Convention, recently held at Cleveland. We refer to Mr. Bail, Director of the A.R.R.L. for the First District. What's more, he claims that the yarn he told is a true story. As we remember it:

The Radio Inspector for the First District has his headquarters in Boston. The present incumbent is a rather pleasant but retiring gent by the name of Kolster. Brockton is a Massachusetts city, famous, among other things, for its Annual Fair. It is not too far from Boston and Mr. Kolster is reported to have taken himself to the Brockton Fair. Among the exhibits a certain amount of radio equipment was on display and among the radio equipment there was a buzzer hooked up with a key, of the type employed by amateurs for code practice.

Naturally the Radio Inspector gravitated to the radio exhibit and ultimately began toying with the key. A young fellow of some sixteen summers listened to the buzzer for a time and then remarked that he, too, knew the code. Mr. Kolster was pleased and turned the key over to the young man who went about his transmission with great zest. After

batting out quite a little message he signed off with W1VH.

If our memory has tricked us regarding the call, we are sorry. It is unimportant except for the fact that the kid used a two-letter call. Looking at the boy rather quizzically, the R. I. seemed to be of the opinion that he was rather young to be the possessor of such an old call.

On being interrogated, the youngster told Mr. Kolster that he had never taken a license examination and that he had seen a lot of call letters in a call book and had appropriated one for himself which he thought had a rather nice swing.

Further interrogation brought out the information that there was very little chance of his being caught and sent to jail for operating his station without a license; that the Radio Inspector was an old fogey, who spent all his time in Boston and would not be able to catch up with our young friend even if he did get to Brockton.

Mr. Kolster was then reported to have said:

"I don't suppose you have any idea who I am, do you?" The youth agreed that he didn't. After the Federal Badge, on the inside of the R. I's. coat had been displayed, the boy got off some such conversation as this:

"Don't some funny things happen when you least expect them? Here I am telling you all about myself not having a license and you being an old fogey and never getting to Brockton and all that. You know, I never thought about what I was doing. Well, I didn't know who you were and I don't suppose you have an idea who I am, do you?"

Mr. Kolster was taken a bit back by the question and agreed that he did not have any idea who the youth was.

"That's a swell break for me!" said the boy, as he turned on his heel and dashed out of the building.

SEES SHORT-WAVE PROMOTING GOODWILL BETWEEN NATIONS

EXTENDING felicitations to the Radio Fellowship at Beverly Hills, Calif., Secretary of Commerce Daniel C. Roper, declared that the Fellowship has splendid purpose in attempting to create a better understanding between the nations of the world through the medium of radio.

"The education of the people in the use of short-wave broadcasting," Secretary Roper said in a letter to M. H. Ryder, Chairman of the organization, "will provide another means of promoting good-will among the people of the different nations."

A Five-Meter "Long Lines" Oscillator

A newly developed method for using this system. Marked stability and increased efficiency are its features, not to forget the simplicity of the oscillator and its low cost.

By ED. RUTH, W2GYL

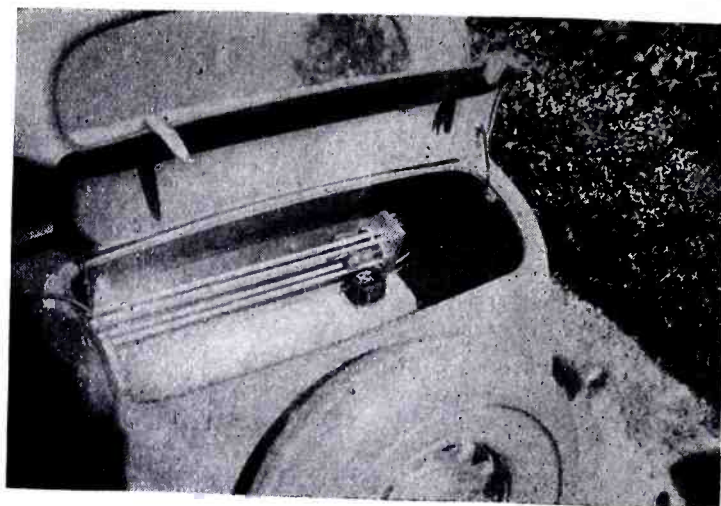

The "Long Lines" oscillator mounted in the baggage compartment of an auto. It has portability plus.

THE ACCOMPANYING drawings illustrate the simplicity as well as the extreme portability of a newly developed method for using the "long lines" oscillator which was introduced to ham radio in its first practical form by George Shuart, W2AMN.

The unit illustrated and described here is actually in use in the station operated at his home, by Arthur H. Lynch, W2DKJ. In this case the oscillator is hung from the picture molding and is several feet away from the remainder of the transmitting equipment. It will be observed that two rather heavy twisted pairs are used to feed the filament current and the plate voltage from the regular power supply.

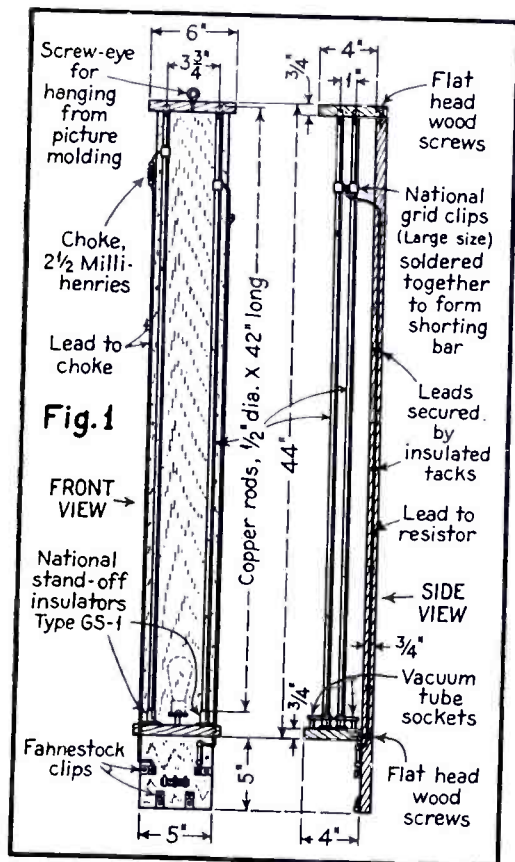

Constructional details of the "long lines" oscillator used at W2DKJ.

Reduces Broadening Effect

The theory of the "long lines" oscillator is now fairly well understood and it is recognized to provide amateurs with a transmitter of marked stability at but a fraction of the cost of a crystal-controlled transmitter. As a matter of fact, it may be constructed at little more expense than the conventional type of circuit. In addition to providing greater efficiency at the transmitter, as far as output power is concerned, this arrangement has the distinct advantage of concentrating the wave from the transmitter, by reducing the broadening effect which is apparent in all frequency-modulated transmitters. This means that many more stations may be operated in a given frequency spectrum without interfering with each other than would be possible if the older forms of modulated oscillator transmitters were employed.

Mechanical Details

The mechanical details given in the accompanying sketches cover a particular type of oscillator for which parts are quite generally available. It will be observed that the four long lines are made up of 1/2 inch, OD copper tubing. The rods in the unit shown here have been silver plated to reduce their high-frequency resistance to a minimum. Each pair is spaced 1 inch apart. If other diameter tubing is employed, the spacing between centers should be twice the outside diameter of the tube. The spacing between the two pair, however, is relatively unimportant. The two pair may be placed as close together as desired, provided sufficient room is left for the locating of the vacuum tubes. The dimensions given are suitable for use with all of the tubes now in general use on five meters.

Insulation

The experienced radio man will recognize that simplicity and economy has been

exercised in the design of this unit, but the efficiency of the unit is maintained at a maximum because of the intelligent application of the most suitable types of insulators in places where they will be effective and the use of ordinary insulating material where losses would not be likely to occur. The four lengths of metal tubing are slipped over the tops of four stand-off insulators. The reason for using high-grade insulators at this point, is because leakage loss would be noticeable under other conditions. It will be observed that the two vacuum-tube sockets are also of the highest grade, being Steatite sockets with guide grooves. To insure perfect continuity of the circuit in this area, heavy copper braid is soldered directly to the contact points on the sockets, as well as directly to the base of all four of the oscillator rods.

Since the upper extremities of the rods are actually cut out of circuit by the shorting bars of the grid and plate cir-

PARTS LIST

- 1—Piece of board, any convenient width, about 48 inches long and 3/4 inch thick.
- 2—Wooden blocks 3/8 inch by 6 inches by 5 inches (approximate).
- 4—Lengths hard-drawn copper tubing, 1/2 inch outside diameter.
- 4—1 inch No. 8 brass, flat-head wood screws.
- 4—Fahnestock clips, any available size.
- 4—National Stand-off insulators, Type GS-1.
- 6—National Grid Grips, Type 12.
- 2—National low loss, Steatite Sockets, with mounting bushings.
- 1—National R-F Choke, Type R-100.
- 1 foot 1/2 inch copper braid.
- 1—10,000-ohm, 10-watt resistor.

cuits, it is not necessary to use more than ordinarily good insulating material and in this case, wood serves the purpose very satisfactorily.

Naturally, all of the wood used in this assembly should be suitably kiln-dried, and if extra protection is desired, it may be painted with hot paraffin.

The simplest form of clip for use in connection with this arrangement seems to be a large size grid clip. Two of these soldered together, form an ideal shorting bar for the grid circuit, and two similarly soldered, form such a bar for the plate circuit. The two clips for the transmission line are, of course, not connected together and they may be soldered directly to the end of the line itself, or the .002 mica isolating condensers may be placed between them and the line.

Coupling

When the type 45 tubes are used in the transmitter, the position of the various units in connection with the oscillator will be as illustrated, for a frequency of approximately 57 megacycles. In this case, the coupling between the transmission

line and the plate circuit, as shown in the photograph, is just about correct for a 440-ohm line, such as is made up by the use of transposition blocks and heavy stranded enamel wire. If a low-impedance line (70 ohms) is employed, the distance between the plate shorting bar and the antenna coupling clips, will be reduced to an inch or less.

Where 801 tubes are used in the oscillator, it will be found that the length of the active portion of the rods in both plate and grid circuits, will be somewhat greater than is shown here for the same frequency.

Duplexing

Another very satisfactory method of employing this oscillator is to locate it within just a few feet of the antenna itself and by so doing, the receiving equipment can be kept well out of the oscillator field, which permits the operator to maintain duplex QSOs with stations very much closer to his own particular frequency than would be possible otherwise. A separate antenna is used for the receiver, in all regular duplex work.

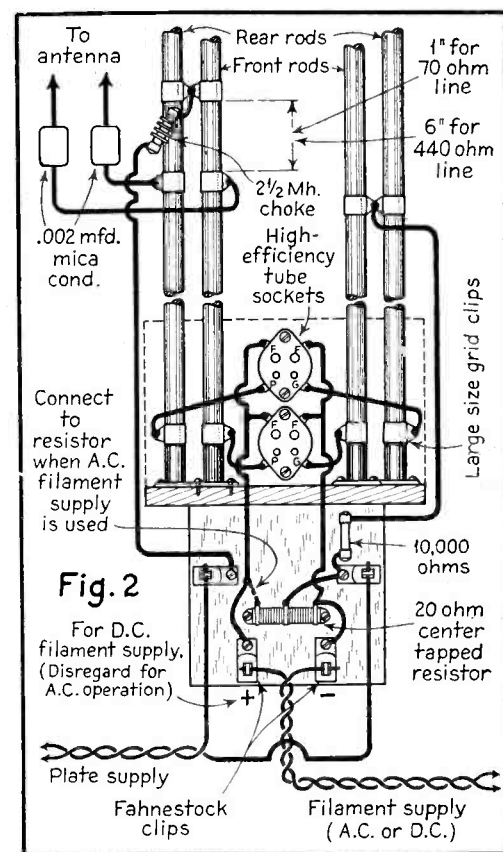

Complete wiring of "long lines" oscillator.

DESIGN OF TRANSFORMERS FOR AMATEURS

AMONG THE MANY requests which the National Bureau of Standards, Washington, D. C., receives for technical information are a considerable number from amateurs who require design data on power transformers for various purposes. It is not practicable to spend the time of the staff working out individual design problems which are not of public interest. For a number of years, such requests have been partially covered by sending a very short typewritten memorandum on general principles of transformer design. The use of this information, however, involved calculations with which many amateurs are not familiar, and left rather too much to the judgment of the individual.

In seeking for means to improve this memorandum, the possibilities of using curves or graphs to reduce computation were considered. By the use of logarithmic and semilogarithmic cross-section paper it has been possible to reduce all of the graphs except one to straight lines, and to reduce the computation to a very small and simple matter. For example, the designer can tell at a glance how much iron and how much copper will be needed for a transformer of any rated output between 1 volt ampere and 10 kilovoltamperes (that is, 1 watt and 10 kilowatts, at unity power factor); how large must be the cross section of the core; how many turns of wire must be used per volt; the sizes of wire; the regulation; the values of the iron loss

and the full-load copper loss; and the efficiency at full load. These labor-saving graphs are the basis of Circular C408 which has just been issued by the Bureau under the title, "Information for the Amateur Designer of Transformers for 25- to 60-Cycle Circuits."

The circular includes definitions of terms used in connection with transformers, and states very briefly the mathematical relations on which the design procedure is based. It gives information on kinds of magnet wire suitable for use in making transformers, and outlines methods of constructing the windings and of forming the core. Special information is given for cases which present unusual difficulties, namely, windings for large currents at a low voltage, windings with low-voltage taps, and transformers to have good regulation with inductive loads at low power factor. Although the method of design is intended primarily for the usual frequency of 60 cycles, it may be readily modified so as to be applicable to 25 cycles and to 50 cycles.

As a result of correspondence between the Bureau and the makers of magnet wire and of transformer steel sheets, it has been possible to include in the circular a list of names and addresses of concerns willing to sell small quantities of material to the amateur constructor. Suggestions are given in the circular as to local sources of wire and of insulating varnish.

Copies of this circular are available from the Superintendent of Documents, Government Printing Office, Washington, D. C., at 5 cents each.



Nelson Case and George Hicks, radio announcers of NBC, after the broadcast of the Army maneuvers near "Hill 300," Sterlingville, N. Y. Note the Army Tanks in the background.

THE FOOTLOOSE REPORTER

SPY CHASER

WITH MESSRS. Mussolini, Laval, Eden and Hitler looking at one another very askance, whilst telling what the others can not do and then going ahead and doing whatever they please, is it any wonder that thoughts of 1914 crop up? We have been told that this next war is to be fought in the air and so when we ran across Ralph Sayres our conversation turned to going on the air, just in case all these European rumors come to pass.

In the world-wide unpleasantness of eighteen years ago, Sayres did his share towards making the world safe for democracy in this country's Navy. Having grown up with Al Grebe and Arthur Lynch, it is small wonder that he should have been a radio operator even before the Germanic Egomanic chose Gott as his Ally and set out to do things to civilization in general. In fact, Ralph had an amateur transmitter when it was no heinous crime to work on whatever wavelength you desired!

So when Mr. Wilson finally decided that we just could not stand it any longer, Sayres enlisted in the branch of the service as a radioman. After some preliminary training he was put on a torpedo boat destroyer and found out that the North Sea in winter is just about as cold as Admiral Byrd says it is down below in Little America. Yes, indeed; the ship he was on ran into a couple of submarines and sent them to depths their designers never intended them to dive . . . sent them there permanently. Then he was assigned to a converted yacht and—but Sayres says that there was not a great deal of excitement in all that . . . it was much more so when one of his shipmates came aboard one night with a pint in each eye and a couple more inside his blouse. This exhilarated gentleman was hungry and so went to the ship's galley, where, being refused food, armed himself with a butcher's knife and a cleaver and ran amok.

Then Sayres was assigned to a converted yacht patrolling the American coast, at the time when German submarines had crossed the Atlantic. When he first went aboard this vessel, he thought that the half-kilowatt outfit was fine and continued to think so until one day his skipper commented on the fact

that whenever the key of the transmitter was held down for an appreciable time it slowed up the ship! This was because the transmitter put such a heavy load on the ship's power plant that there just was not enough current to go around . . . how come, we don't know, but that's the dope.

Later on Sayres was transferred to the Naval Intelligence outfit and it was his job to track down radio stations that were operating without governmental permission and so might be in the hands of spies. He told us that he had on an average of five assignments per day and that the majority of these were nothing more than figments of imagination on the part of over-zealous neighbors.

However, one time the hospital at Lakehurst, N. J., called up and reported that they had been hearing something that sounded like dots and dashes on their telephone and could not account for it. Sayres and his strong-arm squad were rushed out to Lakehurst for an immediate investigation. He arrived in the late afternoon and was told that during certain hours of the day whenever the telephone receiver was removed from its hook and before the operator would ask for the number, these peculiar signals would be heard. This did sound like the work of spies—transmitting at regular times daily. However, nothing untoward was heard that afternoon nor during the night. Next morning a little after ten o'clock, the strange signals commenced. They were intermittent and in neither the Morse nor Continental codes. The office of the telephone company was visited and other lines inspected, but the line to the hospital was the only one on which signals were heard . . . and then only when the line was "open." After listening to the meaningless dots and dashes and trying to put some meaning into them, the idea suddenly came to Sayres that these electrical impulses resembled the intermittent operation of a stock-market ticker! He called the telephone company's office and discovered there was a ticker at a nearby hotel and after a little search found that the lines to the hospital and hotel ran parallel for a short distance and that the electrical impulses of the hotel line were being induced in the hospital's line. Natu-

rally the signals were only present during the time the stock market was open.

The equipment that Sayres carried about consisted of a small, super-sensitive receiver with a loop antenna for locating a transmitter that was operating illegally. On local assignments this apparatus was installed in an automobile and Sayres with his "gang" were liable to be sent out any time of the day or night. Usually the checking-up of the story took but a comparatively few hours, but one job, Sayres told us, took about a month.

Signals, which were unauthorized, were traced to a portion of Long Island that was as wild and desolate, as though it were hundreds of miles from New York. Sayres and his crew sped to the locality and started their search for a house with the usual tell-tale antenna. They fruitlessly inspected every building in the neighborhood and when reporting their negative findings to headquarters were told that the same signals on a different wavelength had been located a few miles north.

Sayres adjusted his receiver to the new frequency, picked up the signals, got the direction and the crew set off. They had traveled a short time, when the station shut down and so left them without a definite destination. They cruised about the place where they thought the station might be, but with no results. Not until the following night were any more signals picked up from this one particular station and then they came from another direction altogether. Sayres then came to the conclusion that the mysterious transmitter was mounted in an automobile, for there was no doubt that the signals were from the same set.

That he was correct in his deduction was evidenced by the fact that for several days, these same signals were traced to many different parts of the Island. The Naval authorities then issued warnings to the police to keep a lookout for a suspicious looking automobile with radio apparatus installed in it. From that time on Sayres' life was made even more miserable, for he and his crew, who were, of course, not dressed in uniforms, were stopped often by the police

(Turn to page 94)

RADIO PROVING POST

THE BOSCH

THE REPORT ON this receiver should prove of special interest. It is the first metal-tube set we have placed on actual test. The results obtained can be applied only to the Bosch Model 575, but at the same time they are some indication as to what may be expected from metal tubes in any well-designed set.

Mechanical

As may be seen from the accompanying illustration, there are four control knobs. From the left, the first knob is on-off switch and volume control. The second knob operates the band-selector switch. The third knob, of the dual-speed type, controls tuning. The fourth knob operates the tone control.

Both volume and tone controls are well graduated and quiet in operation. The band-selector switch is inclined to be stiff, but there appears to be no doubt that good contact is made, which is the important thing.

There are three wave-band positions. Each wave band is provided with a separate scale on the airplane-type dial.

The 540- to 1800-kc scale is black and is marked in both meters and kilocycles. The 1800- to 5800-kc scale is green and is marked only in kilocycles. The 5800- to 18,000-kc scale is red and is marked in kilocycles, with the wavelength in meters spotted for each important band.

The small telephone-switchboard type pilot light just to the left of the band-selector switch changes in color from white, to green, to red, for the successive switch positions. Since the two higher frequency dial scales carry these colors, one can tell immediately to which band the receiver is set for.

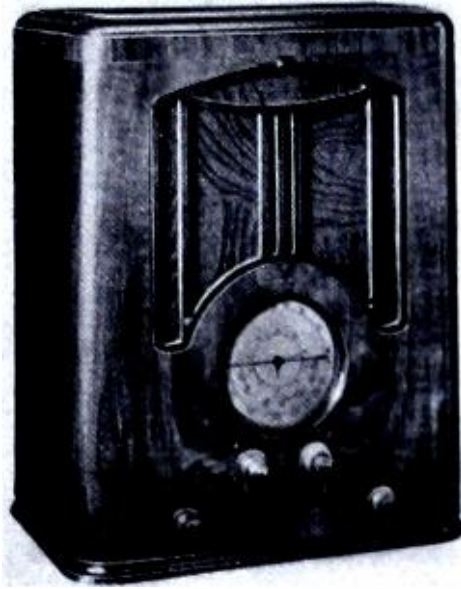

METAL-TUBE SET



Dial calibration is excellent. There is slight backlash in the "second-hand" dial pointer, but not enough to cause inaccuracies in readings.

Electrical

Selectivity in the broadcast band is good, but not excellent. On the whole, it appears to be adequate in all bands.

Sensitivity is better than good, which may account for the apparent slough-off in selectivity at certain frequencies.

MODEL 575

Tests on this receiver were conducted during a week when atmospheric conditions were excessive. However, switching back and forth between a receiver "standard" and the Bosch set, brought out the fact that the latter was the quieter of the two. On one evening it was impossible to use the "standard," the noise was so terrific, whereas the Bosch receiver dug down under and brought up some good signals.

The undistorted audio output of this receiver is given as 2.5 watts, with a maximum output of 3.3 watts. This was not checked, but sounds reasonable.

The Circuit

There is nothing unusual about the circuit of the Model 575. There is a radio-frequency pre-amplifier stage using a 6K7 tube, preceding the mixer-oscillator. This is shown in the block diagram on this page.

The mixer-oscillator tube is a 6A8. The mixer section feeds a single stage intermediate-frequency amplifier using a 6K7 tube. The signal from the i-f amplifier is fed to the 6H6 duo-diode tube.

The diodes of the 6H6 are connected together and serve as second detector and automatic volume control. The direct-current component of the signal in the diode load circuit is used to control the bias (gain) of the 6K7 r-f tube and the 6K7 i-f tube. This is indicated in the diagram. The audio frequency component of the signal in the diode load circuit is passed through the manual volume control to the type 6F5 audio-frequency tube where it is amplified and fed to the 6F6 power pentode tube. The 6F6 tube pumps the signal into the dynamic loudspeaker.

A type 80 rectifier tube is used in the power-supply unit of this receiver. It is not shown in the block diagram.

The feature of the circuit is the "Centr-O-Matic" unit. This is a separately shielded case containing all the antenna, radio-frequency and oscillator coils, as well as the adjusting condensers. These coils are connected directly to the contacts of the band-selector switch—no wire leads at all. According to the manufacturer, 104 soldered connections and 49 leads have been dispensed with.

There is no question that this system reduces circuit losses, and where they

(Turn to page 93)

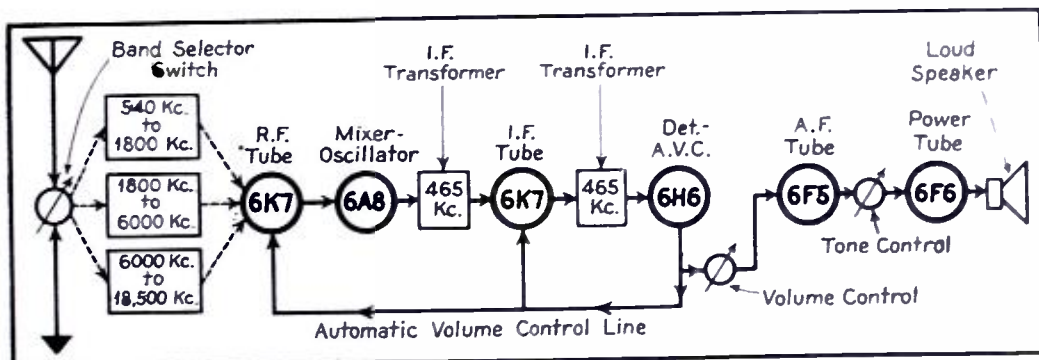

Simplified block diagram of the Bosch Model 575 Metal-Tube Receiver. Complete coil complement is not shown.

BACKWASH

A PAGE GIVEN OVER TO THE EXPRESSIONS AND OPINIONS OF READERS

HAM GAB

Editor, ALL-WAVE RADIO:

The other evening I lit up the filaments of my brand new two-band receiver and got all set to gather in a few earfulls of what was transpiring on the high-frequency bands. And did I? Well, I'll say so.

Naturally I got a kick out of listening to London and Berlin, but, thought I, "the real short-wave stuff is down where the Hams are holding forth," and so there I went. And what did I hear? This:

"Well, old man, your modulation is certainly great tonight. What did you do to your outfit?"

"Old man, if I were you, I'd make certain changes in order to get your modulation a little better. Now I did—blah-blah-blah-blah—to mine and you gotta admit that my modulation is better than it was last week, isn't it?"

"How's my modulation?" Your's is swell."

And so on, ad nauseam.

Now if I might make so bold as to ask a question, is the subject of modulation the only one in which Hams are interested? I fished around for quite awhile and I give you my word, Mr. Editor, that the only thing I heard on amateur phone was a discussion of modulation. Having broadcast in the younger days of radio, I am acquainted with "mike-fright," but it seems to me that after a man has been on the air with his own station as long as some of these men have, that some other topic would come up naturally. Or did I hit upon an evening when all the world and its brother had just changed some part of their setup and was looking for criticism of the results? If this was not the case, why don't you start a discussion that will be of interest to Hams and which would give the non-transmitting radio enthusiast, like myself, some incentive to listen in on the Hams with the idea that something of interest might be picked up.

Good luck to ALL-WAVE RADIO. It's a swell book. Keep it up.

"CONSTANT READER"

We presume that by "Constant Reader" you mean that you have read the first issue again and again. When your copy gets dog-eared, trade it for a new one!

Conversations—Ham or Diplomatic—may be excellent or downright putrid. Possibly you picked a poor night, but one fact is clear, you were not listening in on the 20-meter band. Try it, and give us another report. And, if by chance, the poor conversations were heard on the 75-meter 'phone band, try it again.

But, 20-, 75- or 160-meter bands, keep in mind the fact that Ham transmitters are not broadcast stations run for the entertainment of the public. Since they are experimental bands, it is only natural that numerous references are made to station efficiency and operation.

It would be nice, of course, to find Ham talk less stereotyped. We do not take to the idea of their putting on a show for the listener, but there are possibilities in the idea of amateurs developing a more interesting "party-line" technique.—Ed.

LIKES 5-METER SET

Editor, ALL-WAVE RADIO:

It was with much interest that I read your new magazine, and I wish to congratulate you, especially on your editorial policy.

Of especial interest to me was the 5-meter receiver, and I am pleased to state that yesterday I completed one and the results so far indicate it to be everything you claim.

R. J. HAGERTY, W6JM1,
LOS ANGELES, CALIF.

Thanks for your report. No doubt you will find of interest the two "5-meter" articles in this issue. They serve to round out the receiver article.—Ed.

AN OLD-TIMER RETURNS

Editor, ALL-WAVE RADIO:

Several days ago, I noticed a copy of ALL-WAVE RADIO on a newsstand and bought it. I have read with much interest both your editorial statement of the purposes of the new magazine and also several of the articles. It seems to me that you are on the right track. I have been much disappointed in recent years not to have been able to find a magazine along these lines.

I began my interest in radio in the early days of the KDKA broadcasts and built a receiver with the old 200 and 201 tubes. The early magazines were help-

ful and dependable, but when the radio boom came on, so far as I am concerned they became practically worthless, except of course, QST, which became too technical for me to follow.

In your September issue, I was especially interested in the articles, "Debunking Radio Circuits," "Signals and Noise," and "Some Frequent Questions Asked About Radio Reception."

In some early issue I would like to see instructions for building at a reasonable cost a receiver having an audio-frequency range up to ten or twelve thousand cycles, covering the broadcast band; also a short-wave set, covering the range down to where one who is not a radio expert could count on getting satisfactory results.

ELWYN N. MOSES,
FORT PIERCE, FLA.

Possibly your assertions as to the lack of dependability of some radio publications are unconsciously born out by your request for the details on a receiver with an audio range extending to ten or twelve thousand cycles. We have something of this sort on tap for an early issue, but its limit will be six or seven thousand cycles—possibly the full, permissible eight thousand.

A good short-wave set is described in this issue. Others will follow.—Ed.

FROM A HAM

Editor, ALL-WAVE RADIO:

Congrats on your first issue of ALL-WAVE RADIO. I would say as an amateur that it is FB (fine business). It should grow.

I guess it's quite a problem to know just what to put into the magazine, but I'm sure if enough Fans would help out, it would be an easy task.

A lot of radio mags I read are filled with so much stuff that isn't straight. Maybe I'm different, but I would think that a mag is printed for the benefit of John Q. Public, not the editors.

You are right in not publishing the data on a receiver or transmitter unless it has been tested. I have tried a number of so-called "tested" sets and found myself out dough in the end.

You fellows who are planning to get "tickets," take my advice and don't "boot-leg." There is a lot of this going on in

(Turn to page 96)

CHANNEL ECHOES

BY ZEH BOUCK

IT APPEARS from press reports that foreign writers who express anti-Nazi views are *persona non grata* in Germany. By the time television crawls around the corner, the American fan may see something like this flicker across the screen:

SCENE: A modest *Hotel* on the *Strasse Adolphe*, Berlin. Time: "The immediate future" (about 1956). It is evening as the scanner starts, disclosing one Zeh Bouck, gray and stooped (pronounced in one syllable), and gazing dreamily at a tiny glass of *Wacholderbranntwein*. An imperious knock is heard at the door. Z. B. downs the *Wacholderbranntwein*, chokes, and then calls out in his best high-school German (four years of it—the first term taken eight times).

Z. B.: *Herein!*

The door opens, admitting a Suave Young Man who looks as if he might be selling Fuller Brushes. He clicks his heels and bows.

The Suave Young Man: *Ist Herr Bouck zu Hause?*

Z. B. nodding: I am Herr Bouck.

S. Y. M.: Herr Zeh Bouck?

Z. B. (using the remaining one-third of his vocabulary): *Ja*.

S. Y. M.: Did you on the Saturday of September 1st 1934, Herr Bouck, state in a New York paper that you didn't think much of the Spanish announcer over DJB?

Z. B.: I don't remember. That's a long time and many *Wacholderbranntweine* ago. I may have, though. It sounds logical enough.

S. Y. M.: *Wirklich!* And did you in that same issue that there was entirely too much talk and not enough music on the Zeesen programs state?

Z. B.: That's possible too. Have some *Wacholderbranntwein?* (Z. B. passes the empty glass.)

S. Y. M.: So! And did you not also the same day in that same paper write that the piano melody played as an identifying signal sounded like a cat on the piano walking—except that a cat would not be quite so monotonous?

Z. B.: I don't remember whether I said cat or not.

S. Y. M.: *O, pfui!*

Z. B.: Phooey yourself—

S. Y. M.: *Gottsferdamp!* to you. Herr Bouck, it is my sad duty to tell you that within twenty-four hours you must Germany leave. If you have not in twenty-four hours gone, I shall be forced to send several storm troopers and *Schutzmanne* to escort you to the



ZEH BOUCK
Radio's Severest Critic

frontier. Understand, you are not being expelled from Germany—you are only being requested to leave. *Leben zie woll* (Exit Suave Young Man with a farewell click of his heels.)

Z. B. (at the telephone): Room service, please. Hello—send up enough *Wacholderbranntwein* to last twenty-four hours. *Ja*, twenty-four hours.

THE PROBLEM of congestion and code interference on the short-wave 'phone channels is rapidly assuming proportions which should justify international action. Conditions are such as to make a joke of the existing Madrid agreement—rendering it an agreement to disagree. The 31-meter band is typical of the whole mess.

It was agreed that the channels between 9,500 and 9,600 kilocycles would be allocated to short-wave broadcasting. As virtually all the short-wave stations have an international range, there is room for only ten stations within that band. There are no less than 26 stations that should be operating within this band, and 15 of them are actually radiating between 9.5 and 9.6 mc.

The Madrid agreement stipulates that no country can assign a frequency which will result in interference with the international service of an existing station in another country. Thus new stations are automatically forced out of the agreed 9,500-9,600-kc band, into bands allocated for code transmission. This can be done, because all countries re-

served the right to assign their own frequencies, regardless of the band agreement (which is thereby practically abrogated and nullified), providing they do not interfere with other services.

The United States being possibly the most powerful of the signatories, it is probable that this country alone could bring to bear sufficient influence to promote a new conference. It is about time that the short-wave organizations (including the American Radio Relay League, which has its own bones to pick) got after Congress and started the ball rolling toward Madrid!

EUREKA! We have it. Just thumbing through our copy of the "International Radio Telegraphic Conference Madrid 1932," we experienced a flash that in anyone else would be little short of genius. *Ergo*—an amazingly simple method whereby Congress can be made to take action along the lines suggested in the preceding paragraph.

It was agreed, in old Madrid, that the international distress call for 'phone stations—the SOS of the radiotelephone—would be the French expression, "M'aider." This means, "aid me—help!"—and is pronounced "mayday." It should be sufficient merely to point out this fact to the Senate in order to stimulate the necessary action, which, ultimately, will result in a new international conference where all our woes may be aired and—perhaps—remedied.

However, if it should prove necessary to go into detail, as Will Rogers found out is occasionally the case with Congress, we shall corner those Senators who were responsible for the altered uniforms in the Senate restaurant. The reader will recall that the collars of the waiters had embroidered upon them in red letters, "U. S. S. R.," which obviously stood for United States Senate Restaurant. Unfortunately, the letters also stand for Union of Soviet Socialistic Republics—in other words, Russia! This was immediately pounced upon by nimble-witted Senators as a bit of insidious Red propaganda, perpetrated under the very dome of the Capitol, which must be trampled under foot even if the poor waiters' necks got in the way. Legislative wheels whirred into action (as they never have before nor since) and either the inscription was changed or the waiters now go collarless—we forget which.

(Turn to page 94)

CT1AA	Antonio Augusto de Aguiar, 144, Lisbon, Portugal.	CP5	Radio CP5, Casila 637, La Paz, Bolivia.	LSN-LSL, et al.	Compania Internacional, 143 Defensa, Buenos Aires, Argentina.
CT1CT	Oscar G. Lomelino, Rua Gomez Freire 79-2 D, Lisbon, Portugal.	El Prado	Apartado 98, Riobamba, Ecuador.	LSX	Transradio Internacional, San Martin 329, Buenos Aires, Argentina.
CT1GO	Portugese Radio Club, Parade, Portugal.	HC2AT	Radiodifusora HC2AT, P. O. Box 872, Guayaquil, Ecuador.	OAX4D	Radiodifusora OAX4D, All-American Cables, Inc., (L. N. Anderson, Mgr.) Calle de San Antonio, 677; Casilla 2336, Lima, Peru.
DAF	Hauptfunkstelle Nordeich, Norden-Land, Germany.	HC2ET	Radiodifusora del Telegrafo, Casilla 249, Guayaquil, Ecuador.	OAX4Q	Radiodifusora OAX4Q, Roberto Grelland & Cia., Apartado 1242, Lima, Peru.
DJA, et al.	German Short Wave Station, Broadcasting House, Berlin, Germany.	HC2JSB	Ecuador Radio Station HC2JSB, Juan S. Behr, Prop., Guayaquil, Ecuador.	OCI-OCJ	All-America Cables, Inc., Lima, Peru.
Dutch Phones	Partstaat 29, S'Gravenhage, Holland.	HC2RL	P. O. Box 759, Guayaquil, Ecuador.	PPU-PPQ, et al.	Caixa Postal 500 Rio de Janeiro, Brazil.
EAQ	P. O. Box 951, Madrid, Spain.	HCJB	Casilla 691, Quito, Ecuador.	PRA8	Radio Station PRA8, Radio Club of Pernambuco; "The Voice of North," Pernambuco, Brazil.
EA8AB	Radio Club Tenerife, Alvarez de Lugo 1, Santa Cruz de Tenerife, Canary Islands.	HCK	Radiodifusora HCK, Quito, Ecuador.	PRF5-PSK	Comp. Radio Internacional Do Brazil, P. O. Box 709, Rio de Janeiro, Brazil.
EHY-EDM	Piy Margall 2, Madrid, Spain.	HJA7	Radio HJA7, Cucuta, Colombia.	VP3MR	Radio Station VP3MR, Georgetown, British Guiana.
English Phones	Engineer-in-Chief's Office (Radio Branch) G.P.O. Armour House, London, EC1.	HJ1ABB	Apartado 715, Barranquilla, Colombia.	YV2RC	Apartado Correos 2009, Caracas, Venezuela.
English Ships	Connaught House, 63, Aldwych, London W.C. 2, England.	HJ1ABD	Estacion HJ1ABD, Cartagena, Colombia.	YV3RC	Radiodifusora Venezuela, YV3RC, Caracas, Venezuela.
French Phones	166 Rue de Montmartre, Paris, France.	HJ1ABE	Apartado 31, P. O. Box 252, Cartagena, Colombia.	YV4RC	Estacion S.A.R., Este 10 bis N. 71, Caracas, Venezuela.
G6RX	Rugby Radio Hillmorton, Warwickshire, England.	HJ1ABG	Apartado 816, Barranquilla, Colombia.	YV5RMO	Box 214, Maracaibo, Venezuela.
GSA-GSH, et al.	British Broadcasting Corporation, Broadcasting House, London, W.1, England.	HJ1ABJ	"La Voz de Santa Marta," Radio HJ1ABJ, Santa Marta, Colombia.	YV6RV	"La Voz de Carabobo," Radio YV6RV, Valencia, Venezuela.
HAS-HAT	Director Radio, Hungarian Post, Gyali St. 22, Budapest, Hungary.	HJ2ABA	"La Voz Del Paiz," Tunja, Boyaca, Colombia.	YV8RB	Radiodifusora YV8RB, "La Voz de Lara," Barguisimento, Venezuela.
HB9B	Radio Club, Box 1, Basle, Switzerland.	HJ2ABC	Pompilio Sanchez, Cucuta, Colombia.	YV10RC	Radiodifusora YV10RSC "La Voz del Tachira," San Cristobal, Venezuela.
HBL-HBP et al.	Information Section, League of Nations, Geneva, Switzerland.	HJ3ABD	Colombia Broadcasting, Apartado 509, Bogota, Colombia.	YVQ-YVR	Servicio Radiotelegraphico, Maracay, Venezuela.
HVJ	Radio HVJ, Castine, Pio IV, Vatican City, Vatican, Italy.	HJ3ABF	Apartado 317, Bogota, Colombia.	ZP10	Radio Prieto ZP10, Asuncion, Paraguay.
IAC	Coltano Radio, Piza, Italy.	HJ3ABA	"La Voz de La Victor," Apartado 565, Bogota, Colombia.		
IRM-IRW	Italo Radio, Via Calabria N. 46/48, Rome, Italy.	HJ3ABI	Apartado 513, Bogota, Colombia.		
JKJ1	Ministere Du Commerce, Administrator des Telegraphes, Oslo, Norway.	HJ4ABA	Emisora HJ4ABA, "Ecos de la Montana," Medellin, Colombia.		
OER2	Radio OER2, Vienna, Austria.	HJ4ABB	Radio Manizales, Apartado 175, Manizales, Colombia.		
ORK-ORG	Director de Comunicaciones, Bruxelles, Belgium.	HJ4ABC	Radiodifusora HJ4ABC "La Voz de Pereira," Pereira-Caldas, Colombia.		
OXY	Stateradiofonien Heibersgade 7, Copenhagen, Denmark.	HJ4ABE	Radiodifusora de Medellin, Medellin, Colombia.		
PCJ	Philips Radio PCJ, Eindhoven, Holland.	HJ4ABL	"Ecos de Occidente," P. O. Box 50, Manizales, Colombia.		
PHI	Phillips Radio PHI, Huizen, Holland.	HJ5ABC	"La Voz de Colombia," Radiodifusora HJ5ABC, Cali, Colombia.		
PIIJ.	Radio Station PIIJ, Dr. M. Hellingman, Owner and Operator, Dordrecht, Holland.	HJ5ABD	"La Voz del Valle," Cali, Colombia.		
Pontoise	Minister des Postes, 193 Rue de Grenelle, Paris, France.	HJ5ABE	Radiodifusora HJ5ABE, Cali, Colombia.		
RNE-REN RV59	Radio Centre, Solianka 12, Moscow, U.S.S.R.	HJB	Marconi Telegraph Co., Apartado 1591, Bogota, Colombia.		
		HJN	Ministero de Correos y Telegraph, Bogota, Colombia.		
		HJY	All-America Cables, Inc., Bogota, Colombia.		
		HKE	Observatoria Nacional de San Bartolome, Bogota, Colombia.		
		HKV	Radiodifusora HKV, Radio Dept.—War Ministry, Government of Colombia, Bogota, Colombia.		

SOUTH AMERICA

Call	Address
CEC	CIA Internacional de Radio, Casilla 16-D, Santiago, Chile.

UNITED STATES

Call	Address
Dixon Stations	140 Montgomery St., San Francisco, Cal.
W1XAL	70 Brookline Ave., Boston, Mass.
W1XK	Hotel Statler, Boston, Mass.
W2XAD-W2XAF	General Electric Co., Schenectady, N. Y.
W2XE	485 Madison Ave., New York, N. Y.
W3XAU	1622 Chestnut St., Philadelphia, Pa.
W3XL-W3XAL	30 Rockefeller Plaza, New York, N. Y.
W4XB	Isle of Dreams Broadcasting Corp.; Radio W4XB, Herald Bld., Miami, Florida.
W8XAL	Crosley Radio Corp., Cincinnati, Ohio.
W8XK	William Penn Hotel, Pittsburgh, Pa.
W9XAA	Navy Pier, Chicago, Ill.
W9XF	20 North Wacker Drive, Chicago, Ill.
W9XBS	Radio WVD, 517-Federal Office Bldg., Seattle, Wash.
WVD	

SHORT-WAVE STATION LIST

STAR BROADCASTERS INDICATED BY BOLD TYPE; PHONE (P); EXPERIMENTAL (E).

KC Meters Call	Location	Time	KC Meters Call	Location	Time
21540 13.92 W3XK	Pittsburgh, Pa.	7-9 A.M.	18170 16.51 CGA	Drummondville, Que.	(P) Phones GBB mornings
21530 13.93 GSJ	Daventry, England	6-8:45 A.M.	18135 16.54 PMC	Bandoeng, Java	(P) Phones PCK-PCV early mornings
21500 13.95 NAA	Washington, D. C.	(E) Time signals regularly	18115 16.56 LSY3	Buenos Aires, Arg.	(E) Phones DFB-FTM-GAA-PPU A. M.
21420 14.01 WKK	Lawrenceville, N. J.	(P) Phones LSN-PSA daytime	18040 16.63 GAB	Rugby, England	(P) Phones LSM noon
21160 14.19 LSL	Buenos Aires, Arg.	(P) Phones GAA mornings; DFB and EHY irregular	17980 16.69 KQZ	Bolinas, Calif.	(E) Tests and relays to LSY irreg.
21080 14.23 PSA	Rio de Janeiro, Brazil	(P) Phones WKK-WLK daytime	17940 16.72 WQB	Rocky Point, N. Y.	(E) Tests with LSY mornings
21060 14.25 KWN	Dixon, Calif.	(P) Phones afternoon irregular	17900 16.76 WLL	Rocky Point, N. Y.	(E) Relays to Geneva and Germany mornings
21020 14.29 LSN	Buenos Aires, Arg.	(P) Phones WKK-WLK daily; EHY, FTM irregular	17850 16.81 LSN	Buenos Aires, Arg.	(P) Phones S. A. stations irreg.
20860 14.38 EHY	Madrid, Spain	(P) Phones LSM-PPU-LSY mornings	17830 16.82 PCV	Kootwijk, Holland	(P) Phones PLE early mornings
20860 14.38 EDM	Madrid, Spain	(P) Phones LSM-PPU-LSY mornings	17790 16.86 GSG	Daventry, England	6-8:45 A.M. 9:00 A.M.-12:00 noon
20380 14.72 GAA	Rugby, England	(P) Phones LSL mornings; LSY-LSM-PPU irregular	17780 16.87 W3XAL	Bound Brook, N. J.	9 A.M.-1 P.M. daily except Sunday
20040 14.97 OPL	Leopoldville, Belg.	(P) Congo Africa Tests with ORG mornings	17775 16.88 PHH	Huizen, Holland	Mon. Thurs. Fri. 7:30-9:30 A.M. Sat. & Sunday 7:30-10:00 A.M.
20020 14.99 DHO	Nauen, Germany	(P) Phones PPU-LSM-YVR mornings	17760 16.89 DJE	Zeesen, Germany	7:00-11:30 A.M.
19980 15.02 KAX	Manila, P. I.	(P) Phones KWU evenings	17750 16.91 IAC	Piza, Italy	(P) Phones and Tests to ships A.M.
19820 15.14 WKN	Lawrenceville, N. J.	(P) Phones GAU mornings	17740 16.91 HSP	Bangkok, Siam	(P) Phones DFA-DGH-KAY early mornings
19720 15.21 EAQ	Madrid, Spain	(P) Relays and tests in A.M.	17699 16.95 IAC	Piza, Italy	(P) Phones and tests to ships A.M.
19680 15.24 CEC	Santiago, Chile	(P) Phones OCI-HJY afternoons	17545 17.10 VWY	Poona, India	(P) Phones GAU-GBC-GBU mornings
19600 15.31 LSF	Buenos Aires, Arg.	(P) Phones and tests irregularly	17520 17.12 DFB	Nauen, Germany	(P) Phones PPU-YVR-KAY mornings
19530 15.36 EDR2	Madrid, Spain	(P) Phones LSM-PPU-YVR mornings	17480 17.16 VWY	Poona, India	(P) Phones GAU-GBC-GBU daytime
19530 15.36 EDS	Madrid, Spain	(P) Phones LSM-PPU-YVR mornings	17260 17.37 DAF	Nordenland, Germany	(P) Phones ships mornings
19520 15.37 IRW	Rome, Italy	(P) Phones LSM-PPU mornings	17120 17.52 WOO	Ocean Gate, N. J.	(P) Phones ships daytime
19500 15.40 LSQ	Buenos Aires, Arg.	(P) Phones daytime irregularly	17120 17.52 WOY	Lawrenceville, N. J.	(P) Phones England irreg.
19355 15.50 FTM	St. Assise, France	(P) Phones LSM-PPU-YVR mornings	17080 17.56 GBC	Rugby, England	(P) Phones ships daytime
19345 15.52 PMA	Bandoeng, Java	(P) Phones PCK-PDK early mornings	16305 18.39 PCL	Kootwijk, Holland	(P) Special relays and phones irreg.
19260 15.58 PPU	Rio de Janeiro, Brazil	(P) Phones DFB-EHY-FTM mornings	16300 18.44 WLK	Lawrenceville, N. J.	(P) Phones England irreg.
19235 15.60 DFA	Nauen, Germany	(P) Phones HSP-KAX early mornings	16240 18.47 KGO	Manila, P. I.	(P) Phones JVE-KWU evenings
19220 15.61 WKF	Lawrenceville, N. J.	(P) Phones GAS-GAU mornings	16214 18.50 FZR	Saigon, Indo-China	(P) Phones FTA-FKT early A.M.
19200 15.62 ORG	Brussels, Belgium	(P) Phones OPL mornings	16050 18.69 JVC	Nazaki, Japan	(P) Phones Hong Kong early A.M.; Phones JVE-KGO-PL.E early A.M.
19140 15.68 LSM	Buenos Aires, Arg.	(P) Phones DFB-FTM-GAA-GAB mornings	16030 18.71 KKP	Kankuku, Hawaii	(P) KWU afternoons and evenings
18970 15.81 GAQ	Rugby, England	(P) Phones ZSS mornings	15930 18.83 FYC	Pontoise, France	(P) Phones 9:00 A.M. and irreg.
18960 15.82 WQD	Rocky Point, N. Y.	(E) Tests LSY irregularly	15880 18.89 FTK	St. Assise, France	(P) FZR-FZS-LSM-PPU-YVR mornings
18950 15.83 HBF	Geneva, Switzerland	(E) Phones So. America mornings	15860 18.90 JVD	Nazaki, Japan	(P) Phones Shanghai early A.M.
18910 15.86 JVA	Nazaki, Japan	(P) Phones and tests irregular	15860 18.90 CEC	Santiago, Chile	(P) Phones OCJ mornings
18890 15.88 ZSS	Klipkewvel, So. Africa	(P) Phones GAO-GAU mornings	15810 19.02 LSL	Buenos Aires, Arg.	(P) Phones GAA mornings
18860 15.91 WKM	Rocky Point, N. Y.	(E) Tests and relays irregularly; Phones PCV mornings	15760 19.04 JYT	Kemikawa-Cho, Japan	(E) Tests KKW-KWE-KWU evenings
18830 15.93 PLE	Bandoeng, Java	(P) KWU evenings; music at times	15740 19.06 JIA	Chureki, Japan	(P) Phones Nazaki early A.M.
18740 16.01 PCP	Kootwijk, Holland	(P) Relays and phones mornings irregular	15670 19.15 WAE	Brentwood, N. Y.	(E) Tests afternoons
18680 16.06 OCI	Lima, Peru	(P) Phones CEC-HJY days; WKK-WOP noon	15660 19.16 JVE	Nazaki, Japan	(P) Phones PLE early A. M.; KTO evenings.
18620 16.11 GAU	Rugby, England	(P) Phones VWY-ZSS early A.M.; Lawrenceville, daytime	15625 19.20 OCJ	Lima, Peru	(P) Phones CEC daytime
18480 16.23 HBH	Geneva, Switzerland	(E) Relays to N. Y. mornings irreg.	15620 19.21 JVF	Nazaki, Japan	(P) Phones KWO-KWU after 4 P.M.
18440 16.25 HJY	Bogota, Colombia	(P) Phones CEC-OCI noon; music at times	15595 19.24 DFR	Nauen, Germany	(E) Tests and relays mornings irreg.
18405 16.30 PCK	Kootwijk, Holland	(P) Phones PLE-PMC early A.M.	15430 19.44 KWE	Bolinas, Calif.	(P) Tests JYK-JYT-PL.E evenings
18350 16.35 FZS	Saigon, Indo-China	(P) Phones FTK early mornings	15415 19.46 KWO	Dixon, Calif.	(P) Phones JVF evenings
18340 16.36 WLA	Lawrenceville, N. J.	(P) Phones GAS mornings	15410 19.47 Prado	Riobamba, Ecuador	5:00-7:00 P.M. Sunday
18310 16.38 GAS	Rugby, England	(P) Phones WLA-WMN mornings	15370 19.52 HCS	Budapest, Hungary	Sunday 8-9 A.M.
18295 16.39 YVR	Maracay, Venezuela	(P) Phones DFB-EHY-FTM mornings	15355 19.54 KWU	Dixon, Calif.	(P) Phones Japan, Manila and Java evenings
18250 16.43 FTO	St. Assise, France	(P) Phones LSM-LSY mornings	15330 19.56 W2XAD	Schenectady, N. Y.	2-3 P.M. Weekdays-Sunday 10:30 A.M.-4 P.M.
18200 16.48 GAW	Rugby, England	(P) Relays and phones N. Y. irreg.	15280 19.63 DJQ	Zeesen, Germany	8-11:30 A.M.
18190 16.49 JVB	Nazaki, Japan	(P) Phones Java early mornings	15270 19.64 W2XE	Wayne, N. J.	10 A.M.-5 P.M.
			15260 19.66 CSI	Daventry, England	12:15 P.M.-4 P.M.
			15252 19.67 RIM	Tashkent, U.S.S.R.	(P) Phones RKI early mornings
			15243 19.68	Pontoise, France	6-10 A.M.
			15220 19.71 PCJ	Eindhoven, Holland	Sunday 7:30-10:00 A.M. Tues. 3-6 A.M. Wed. 7-11 A.M.

KC Meters Call	Location	Time	KC Meters Call	Location	Time
15220 19.71 W8KX	Pittsburgh, Pa.	9 A.M.-7 P.M.	12250 24.49 TYB	Paris, France	(P) Phones JVH-XGR and ships irreg.
15200 19.74 DJB	Zeosen, Germany	3:45-7:15 A.M.			
15140 19.82 GSF	Daventry, England	8:00-11:30 A.M.	12240 24.51 TFJ	Reykjavik, Iceland	(P) Phones England days
15121 19.84 HVJ	Vatican City, Vatican	6-8:45 A.M. 9 A.M.-12 noon	12220 24.55 FLJ	Paris, France	(P) Phones ships irreg.
15055 19.92 WNC	Hialeah, Fla.	10:30-10:45 A.M.	12215 24.56 TYA	Paris, France	(P) Algeria, days—"Inverted Speech"
15040 19.95 RKI	Moscow, U.S.S.R.	(P) Phones daytime			
15040 19.95 HIR	Santo Domingo, R. D.	(P) Phones RIM early A.M.	12060 24.88 PDV	Kootwijk, Holland	(P) PLE - PLV - PMC early mornings
14980 20.03 KAY	Manila, P. I.	(P) Phones WNC daytime	12035 24.93 HIBO	Geneva, Switzerland	(E) Relays programs & phones irreg.
14940 20.06 HJB	Bogota, Colombia	(P) Phones DFC-DFD-GCJ early A.M.; KWU evenings	12020 24.95 VIY	Rockbank, Australia	(P) Tests CJA6 early A.M. and evenings
14920 20.11 KOH	Kahuku, Hawaii	(P) Phones WNC-PPI-YVQ days	12010 24.97 CJA6	Drummondville, Que.	(P) Tests VIY early A.M. and evenings
14845 20.19 OCJ2	Lima, Peru	(P) Tests irregularly	12000 25.00 RNE	Moscow, U.S.S.R.	Daily 3-6 P.M. Wed. 6-7 A.M. Sun. 6-7 A.M. 10-11 A.M.
14800 20.27 WQV	Rocky Point, N. Y.	(P) Phones HJY and others daytime			
14710 20.39 IRG	Nassua, Eritrea, Africa	(E) Tests Europe irreg.	11991 25.02 FZS	Saigon, Indo-China	(P) Phones FTA-FTK early A.M.
14690 20.42 PSS	Rio de Janeiro, Brazil	(P) Phones and tests with JVH 5:00 to 7:00 A.M.	11950 25.11 KKQ	Bolinas Calif.	(P) Relays programs to Hawaii eve.
14653 20.47 GBL	Rugby, England	(P) Phones ISL-WLK-WOK daytime	11940 25.13 FTA	St. Assise, France	(P) Phones FZS-FZR early A.M.
14620 20.52 EHY	Madrid, Spain	(P) Phones Nazaki, early A.M.	11935 25.14 YNA	Managua Nicaragua	(P) Cent. and S. A. stations, days
14620 20.52 EDM	Madrid, Spain	(P) Phones LSM mornings irreg.	11885 25.23	Pontoise, France	10:15 A.M.-1:15 P.M. 2-5 P.M.
14600 20.55 JVH	Nazaki, Japan	(P) Phones PPU-PSA-PSE mornings	11870 25.26 W8XK	Pittsburgh, Pa.	5-9 P.M.
14600 20.55 JVH	Nazaki, Japan	(E) Phones DFB-GTJ-PCJ-TYB early mornings and B.C. music	11860 25.29 GSE	Daventry, England	9 A.M.-12 noon
14590 20.56 WMN	Lawrenceville, N. J.	12 A.M.-1 A.M. Daily: 4-5 P.M. Mon. and Tues.	11830 25.36 W2XE	Wayne, N. J.	5-7 P.M.
14550 20.60 HBJ	Geneva, Switzerland	(P) Phones England daytime	11811 25.40 2RO	Rome, Italy	8:15-9 A.M. 9:15-10:15 A.M. 12 noon-1 P.M.-1:45-5 P.M.
14530 20.65 LSN	Buenos Aires, Arg.	(E) Relays to Riverhead daytime	11800 25.42 CO9WR	Sancti-Spiritus, Cuba	4-6:30 P.M. 9-11 P.M.
14485 20.71 TIR	Cartago, Costa Rica	(P) Phones PSF-WLK-WOK irreg.	11790 25.43 W1XAL	Boston, Mass.	Tues. and Thurs. 6-9 P.M. Sunday 5-7 P.M.
14485 20.71 TIU	Cartago, Costa Rica	(P) Phones WNC daytime	11770 25.49 DJD	Zeosen, Germany	12 noon-4:30 P.M.-5:05-10:45 P.M.
14470 20.73 WMF	Lawrenceville, N. J.	(P) Phones WNC daytime	11750 25.53 GSD	Daventry, England	1:15-3:20 A.M. 12:15-4 P.M. 4:15-5:45 P.M. 6:00-8:05 P.M. 10-11:05 P.M.
14440 20.78 GBW	Rugby, England	(P) Phones England daytime	11720 25.60 CJRX	Winnipeg, Manitoba	Week days 7:30 P.M.-12 midnight; Sunday 3-10 P.M.
14200 21.20 W10XFB	The Schooner "Morrissey"	(P) Phones Lawrenceville daytime	11713 25.62	Pontoise, France	3-4 A.M.-6-9 P.M. 10 P.M.-12 A.M.
14100 21.25 HJ5ABE	Medillin, Colombia	(E) Irregular	11710 25.63 HJ4ABA	Medillin, Colombia	11:30 A.M.-1 P.M. 6-10:30 P.M.
13900 21.58 WQP	Rocky Point, N. Y.	11:00 A.M.-12 noon daily ex. Sun. 6:00-10:30 P.M.	11680 25.68 KIO	Kaukuku, Hawaii	(P) Phones Far-East early A.M.
13820 21.70 SUZ	Cairo, Egypt	(E) Test daytime	11670 25.71 PPQ	Rio de Janeiro, Brazil	(P) Phones WCG-WET-LSX evenings
13738 21.82 RIS	Tiflis, U.S.S.R.	(P) Phones DFC-DGU-GBB daytime	11660 25.73 JVL	Nazaki, Japan	(P) Phones Taiwan evenings
13690 21.91 KKZ	Bolinas, Calif.	(P) Tests with Moscow irregular	11570 25.93 HH2T	Port-au-Prince, Haiti	(P) Evenings—irregular
13667 21.98 HJY	Bogota, Colombia	(F) Tests Japan and Java early A.M.; days Honolulu	11538 26.00 XGR	Shanghai, China	(P) Tests irregularly
13610 22.04 JYK	Bogota, Colombia	(P) Phones ECE afternoons	11500 26.09 XAM	Merida, Mexico	(P) Phones XDF-XDM-XDR irreg.
13585 22.08 GBB	Kemikawa-Cho, Japan	(E) Tests irregular A.M.	11495 26.10 VIZ3	Rockbank, Australia	(P) Tests CJA4 early A.M.
13545 22.15 PFG	Rugby, England	(P) Phones CGA3-SUV-SUZ daytime	11405 26.26 CJA4	Drummondville, Que.	(P) Phones VIZ3 early A.M.
13415 22.36 GCJ	Rugby, England	(P) Tests mornings irregular	11385 26.35 HBO	Geneva, Switzerland	(E) Phones and relays irregular
13390 22.40 WMA	Lawrenceville, N. J.	(P) Tests with JVH afternoons	11275 26.61 ZAM	Merida, Mexico	(P) Phones XDR-XDM irregular
13345 22.48 YVQ	Maracay, Venezuela	(P) Phones GAS-GBS-GRU-GBW daily	11000 27.27 ZLT	Wellington, N. Z.	(P) Phones VLZ early mornings
13340 22.49 KBJ	Manila, P. I.	(P) Phones WNC-HJB days	11000 27.27 PLP	Bandoeng, Java	(P) Phones early A.M.; broadcasts 10-10:30 A.M.
13285 22.58 CGA3	Manila, P. I.	(P) Phones nights and early A.M.	10975 27.35 OCI	Lima, Peru	(P) Phones CEC-HJY days
13285 22.58 CGA3	Drummondville, Que.	(P) Phones England days	10975 27.35 OCP	Lima, Peru	(P) Phones HKB early evenings
13180 22.76 DGG	Nauen, Germany	(P) Relays to Riverhead days	10910 27.50 KTR	Manila, P. I.	(P) Phones DFC early A.M. irreg.
13075 22.95 VPD	Nauen, Germany	(P) Phones ships days	10850 27.63 DFL	Nauen, Germany	(P) Relays programs afternoons irreg.
13000 23.08 FYC	Suva, Fiji Islands	(P) Phones HJB-HPF-WNC days	10840 27.68 KWV	Dixon, Calif.	(P) Phones Japan, Manila, Hawaii, mornings
12985 23.11 DFC	Paris, France	Sunday 7:30-9:00 A.M.	10790 27.80 YNA	Managua, Nicaragua	(P) Phones So. America days, irreg.
12865 23.32 IAC	Paris, France	(P) Phones FYB-TYB-FTA irreg.	10770 27.86 GBP	Rugby, England	(P) JYS and XGR irreg.; Phones VLK early A.M. and eve.
12840 23.36 WOO	Piza, Italy	(P) Phones ships and tests Tripoli, irreg.	10740 27.93 JVM	Nazaki, Japan	4-7:30 A.M. irregular
12830 23.37 HJC	Piza, Italy	(P) Phones VWY early A.M.	10675 28.10 WNB	Lawrenceville, N. J.	(P) Phones ZFB daytime
12825 23.38 CNR	Ocean Gate, N. J.	Sun. 11:30 A.M.-1 P.M.; 7:15-8:30 P.M. Tues. to Fri. 7:15-8:30 P.M.	10670 28.12 CEC	Santiago, Chile	(P) Phones HJY-OCI daytime
12825 23.38 CNR	Barranquilla, Colombia	(P) Phones ships irreg. mornings	10670 28.12 CEC	Santiago, Chile	8:30-9:00 P.M. Thurs. and Sun.
12800 23.44 IAC	Rabat, Morocco	(P) Phones 2ME near 6:30 A.M.	10660 28.14 JVN	Nazaki, Japan	(P) Phones JIB early A.M.; Relays JOAK irreg.
12800 23.44 IAC	Rabat, Morocco	(P) Phones JLJ early A.M.	10660 28.14 JVN	Nazaki, Japan	4-7:30 A.M. irregular
12800 23.44 IAC	Piza, Italy	(P) Phones Lawrenceville days			
12780 23.47 GBC	Rugby, England	(P) Phones early A.M.			
12396 24.20 CT1G0	Paredo, Portugal				
12394 24.21 DAF	Nordenland, Germany				
12300 24.39 PLM	Bandoeng, Java				
12295 24.40 ZLU	Willmington, N. Z.				
12290 24.41 GBU	Rugby, England				
12280 24.43 KUV	Manila, P. I.				

KC Meters Call	Location	Time	KC Meters Call	Location	Time
10630 28.22 WED	Rocky Point, N. Y.	Relays program service irreg.	9800 30.59 LSI	Buenos Aires, Arg.	(P) Relays very irreg.
10620 28.25 EHX	Madrid, Spain	(P) Phones CEC and EHZ afternoons	9760 30.74 VLJ	Sydney, Australia	(P) Phones PLV-ZLT early A.M.
10610 28.28 WEA	Rocky Point, N. Y.	(E) Tests Europe irreg.	9760 30.74 VLZ	Sydney, Australia	(P) Phones PLV-ZLT early A.M.
10550 28.44 WOK	Lawrenceville, N. J.	(P) Phones LSN-PSF-PSH-PSK evenings	9750 30.77 WOF	Lawrenceville, N. J.	(P) Phones GCU irreg.
10535 28.48 JIB	Tawian, Japan	(P) Phones JBL-JVN early mornings	9710 30.88 GCA	Rugby, England	(P) Phones LSL afternoons
10520 28.52 VK2ME	Sydney, Australia	(P) Phones early A.M. GBP-HVJ	9700 30.93 LQA	Buenos Aires, Arg.	(P) Tests and relays early evening
10520 28.52 VLK	Sydney, Australia	(P) Phones early A.M. GBP-HVJ	9635 31.13 2RO	Rome, Italy	Mon. Wed. Fri. 6-9:00 A.M.
10440 28.74 DGH	Nauen, Germany	(P) Phones HSG-HSJ-HSP early A.M.	9620 31.17 DGU	Nauen, Germany	(P) Phones SUV A.M. Tests and relays irreg.
10430 28.80 YBG	Medan, Sumatra	(P) Phones PLV-PLP early A.M.	9620 31.17 FZR	Saigon, Indo-China	(P) Phones Paris early A.M.
10420 28.79 XGR	Shanghai, China	(P) Tests GBP-KAY early A.M.	9600 31.25 CT1AA	Lisbon, Portugal	Tues. Thurs. Sat. 4:30-7 P.M.
10420 28.79 PDK	Kootwijk, Holland	(P) Phones PLV A.M. and special programs irreg.	9595 31.27 HBL	Geneva, Switzerland	Saturday 5:30-6:15 P.M.
10410 28.82 KES	Bolinas, Calif.	(P) Phones S. A. and Far East irreg.	9590 31.28 W3XAU	Philadelphia, Pa.	11 A.M.-7 P.M.
10400 28.85 KEZ	Bolinas, Calif.	(P) Phones Hawaii and Far East irreg.	9590 31.28 VK2ME	Sydney, Australia	Sundays { 12:30-2:30 A.M. 4:30-8:30 A.M. 9:30-11:30 A.M.
10380 28.90 WCG	Rocky Point, N. Y.	(E) Special program service irreg.	9590 31.28 HP5J	Panama City, Panama	11:45 A.M.-1 P.M. 7:30-10 P.M.
10375 28.92 JVO	Nazaki, Japan	(P) Manchuria and Dairen early A.M.	9580 31.31 GSC	Daventry, England	4:15-5:45 P.M. 6-8:05 P.M. 10-11:05 P.M.
10370 28.93 EHZ	Madrid, Spain	(P) Phones EHX daytime	9580 31.31 VK3LR	Melbourne, Australia	Mon. Tues. Wed. Thurs. 3:15-7:30 A.M. Fri. 10:30 P.M.-2 A.M. Sat. 5-7:30 A.M.
10350 28.98 LSX	Buenos Aires, Arg.	Near 10 P.M. irregular. 6-7:15 P.M. daily	9570 31.34 LKJ1	Jeloy, Norway	5-8 A.M. 10 A.M.-6 P.M.
10335 29.03 ZFD	Hamilton, Bermuda	(P) Phones afternoons	9570 31.33 WIXK	Boston, Mass.	Week days 6 A.M.-12 midnight Sunday 7 A.M.-12 midnight
10330 29.04 ORK	Brussels, Belgium	(P) Tests New York and Buenos Aires evenings.	9565 31.36 VUY	Bombay, India	11:30 A.M.-12:30 P.M. Wed. & Sat. Sunday 7:30-8:30 A.M.
10310 29.10 PPM	Rio de Janeiro, Brazil	(P) Phones GCA-HJY-PSH afternoons	9560 31.38 DJA	Zeesen, Germany	12:30-2:15 A.M. 8-11:30 A.M. 5:05-9:15 P.M.
10300 29.13 LSQ	Buenos Aires, Arg.	(P) Phones GCA-HJY-PSH afternoons	9540 31.45 DJN	Zeesen, Germany	12:30-2:15 A.M. 3:45-7:15 A.M. 5:05-10:45 P.M.
10300 29.13 LSI	Buenos Aires, Arg.	(E) Phone and pgm. service irreg.	9530 31.48 W2XAF	Schenectady, N. Y.	Week days 6:30 P.M.-12 A.M. Sundays 4:15 P.M.-12 A.M.
10290 29.15 DIQ	Zeesen, Germany	Used irregularly.	9510 31.55 GSB	Daventry, England	1:15-3:20 A.M. 9 A.M.-12 noon 12:15-4 P.M. 4:15-5:45 P.M. 6:00-8:05 P.M.
10290 29.15 DIO	Zeesen, Germany	(P) Phones C. A. and S. Am. daytime	9510 31.55 VK3ME	Melbourne, Australia	Wed. to Sat. Inc. 5-7 A.M.
10290 29.15 HPC	Panama City, Panama	(P) Tests VLJ early A.M.	9501 31.56 PRF5	Rio De Janeiro, Brazil	4:45-5:45 P.M. daily 9-10:45 P.M. irreg.
10260 29.24 PMN	Bandoeng, Java	(P) "Inverted Speech" afternoons	9480 31.65 PLW	Bandoeng, Java	(P) Phones Australia early A.M.
10250 29.27 LSK3	Buenos Aires, Arg.	(P) Phones LSL-WOK evenings; special pgm. service irreg.	9480 31.65 KET	Bolinas, Calif.	(P) Phones WEL evenings & nights
10220 29.35 PSH	Rio de Janeiro, Brazil	(P) Phones RIR-RNE early A.M.	9470 31.68 WET	Rocky Point, N. Y.	(E) Tests LSX-PPM-ZFD evenings
10170 29.50 RIO	Bakou, U.S.S.R.	(P) Phones YVR afternoons	9460 31.71	Tripoli, Africa	(P) Phones Italy mornings.
10169 29.50 HSG	Bankok, Siam	(P) Phones WNB daytime	9430 31.80 YVR	Maracay, Venezuela	(P) Tests mornings
10140 29.59 OPM	Leopoldville, Belg-Congo	(P) Phones WNA evenings	9428 31.81 COCH	Havana, Cuba	10 A.M.-12 noon. 4:00-6:30 P.M. 8:00-10:00 P.M.
10140 29.59 OPM	Leopoldville, Belg-Congo	Occasional Saturdays 3:30-4:10 P.M.	9415 31.86 PLV	Bandoeng, Java	(P) Phones PCV-PCK-PDK-VLZ-KWX and KWV early mornings
10080 29.76 RIR	Tiflis, U.S.S.R.	(P) Phones RIO-RNE early A.M.	9400 31.92 XDR	Mexico City, Mexico	(P) Phones XAM irreg. days
10070 29.79 EHY	Madrid, Spain	(P) Phones YVR afternoons	9330 32.15 CGA4	Drummondville, Que.	(P) Phones GCB-GDB-GBB afternoons
10055 29.84 ZFB	Hamilton, Bermuda	(P) Phones WNA evenings	9280 32.33 GCB	Rugby, England	(P) Phones Canada afternoons
10055 29.84 SUV	Cairo, Egypt	(P) Phones CEC-OCF-PSH-PSK afternoons	9180 32.68 ZSR	Kliphewvel, S. Africa	((P) Phones Rugby afternoons seasonally
10040 29.88 HJA3	Barranquilla, Colombia	(P) Phones DFV-DGU-GCA and GCB daytime	9170 32.72 WNA	Lawrenceville, N. J.	(P) Phones GBS-GCU-GCS afternoons
9990 30.01 KAZ	Manila, P. I.	(P) Tests early evenings irreg.	9147 32.79 YVR	Maracay, Venezuela	(P) Phones EHY afternoons
9966 30.08 IRS	Rome, Italy	(P) Phones JVO-KWX-PLV early A.M.	9120 32.88 HAT4	Budapest, Hungary	6:00-7:00 P.M. Sundays
9950 30.13 GBU	Rugby, England	(P) Tests irregularly	9110 32.93 KUW	Manila, P. I.	(P) Tests and phones early A.M.
9930 30.21 HKB	Bogota, Colombia	(P) Phones WNA evenings	9020 33.26 GCS	Rugby, England	(P) Phones Lawrenceville afternoons
9930 30.21 HJY	Bogota, Colombia	(P) Phones CEC-OCF-PSH-PSK afternoons	9010 33.30 KEJ	Bolinas, Calif.	(P) Relays programs to Hawaii eve.
9890 30.33 LSN	Buenos Aires, Arg.	(P) Phones LSQ afternoons	8975 33.43 VWY	Poona, Ind.	(P) Phones GBC-GBU mornings
9870 30.40 JYS	Kenukawa-Cho, Japan	(P) Phones WOK-WLK evenings and nights	8950 33.52 WEL	Rocky Point, N. Y.	(E) Tests with Europe irreg.
9860 30.43 EAQ	Madrid, Spain	4-7 A.M. irregular	8950 33.52 W2XBJ	Rocky Point, N. Y.	(E) Tests irregularly
9840 30.47 JYS	Kenukawa-Cho, Japan	Saturday 1-3 P.M. Daily 5:15-7 P.M. often to 9:30 P.M.	8900 33.71 ZLS	Wellington, N. Z.	(P) Phones VLZ early mornings
9830 30.50 IRM	Rome, Italy	(E) Tests irregular	8830 33.98 LSD	Buenos Aires, Arg.	(P) Relays to N. Y. early evenings
9810 30.58 DFE	Nauen, Germany	(P) Phones JVP-JZT-LSX-WEL mornings			
9800 30.59 GCW	Rugby, England	(P) Relays and tests afternoons irreg.			
		(P) Phones Lawrenceville eve. and nights			

KC Meters Call	Location	Time	KC Meters Call	Location	Time
8790 34.13 IKV	Bogota, Colombia	(E) Tests early evenings and nights	7280 41.20 HJ1ABD	Cartagena, Colombia	11:15 A.M.-1:15 P.M. Sunday. Weekdays 7:15-9:15 P.M.
8790 34.13 TIR	Cartago, Costa Rica	(P) Phones Central America daytime	7210 41.60 EA8AB	Santa Cruz, Canary Is.	5-7:30 P.M. irregular
8790 34.13 HKV	Bogota, Colombia	6:00-11:00 P.M. irregular	7177 41.80 CR6AA	Labito, Angola, Africa	2:30-4:30 P.M. Wed. & Sat.
8775 34.19 PNI	Makasser, D. E. I.	(P) Phones PLV early mornings	7113 42.13 HB9B	Basle, Switzerland	Mon., Thurs., Fri. 4-6 P.M.
8760 34.35 GCQ	Rugby, England	(P) Phones ZSR afternoons	7100 42.25 HKE	Bogota, Colombia	Monday 6-7 P.M. Tues. and Friday 8-9 P.M.
8750 34.29 ZBW	Hong Kong, China	1:00-10:00 A.M. 11:30 P.M.-1:15 A.M.	7080 42.37 P11J	Dordrecht, Holland	Saturday 10:10-11:10 A.M.
8740 34.35 WXV	Fairbanks, Alaska	(P) Phones WXH nights	7080 42.37 VP3MR	Georgetown, Br. Guiana	Sun 7:45-10:15 A.M. Mon 3:45-4:45 P.M. 6:45-7:45 P.M. Wed. Thurs. Sat. 5-7:45 P.M.
8730 34.36 GCI	Rugby, England	(P) Phones VWY afternoons	6990 42.92 JVS	Nazaki, Japan	(P) Phones China mornings early
8680 34.56 GBC	Rugby, England	(P) Phones ships and New York daily	6935 43.25 WEB	Rocky Point, N. Y.	(E) Relays programs evenings
8665 34.62 C09JQ	Camagney, Cuba	11:30 A.M.-12:30 P.M. 8:00-9:00 P.M.	6905 43.45 GDS	Rugby, England	(P) Phones WOA-WNA-WGN evenings
8650 34.68 WVD	Seattle, Wash.	(P) Tests irregularly	6900 43.48 HI3C	LaRomana, R. D.	Daily 12:15-2 P.M. 6-7:30 P.M. Sat. 12 midnight-2:00 A.M.
8560 35.05 WOO	Ocean Gate, N. J.	(P) Phones ships daytime	6860 43.73 KEL	Bolinas, Calif.	(P) Tests KAZ-PLV early A.M.
8470 35.39 DAF	Nordenland, Germany	(P) Phones ships irregularly	6840 43.86 KEN	Bolinas, Calif.	(P) Used irregularly
8404 35.69 HC2AT	Guayaguil, Ecuador	8:00-11:00 P.M. ex. Sunday	6814 41.12 HHH	San Pedro de Macoris, R.D.	Sunday 3-4 A.M. 12:30-2 P.M. 4-6 P.M. Mon. to Sat. inc. 12:30-2 P.M. 7-9 P.M.
8380 35.80 IAC	Piza, Italy	(P) Phones ships irregularly	6755 44.41 WOA	Lawrenceville, N. J.	(P) Phones GDW-GDS-GCS evenings
8214 36.50 HCJB	Quito, Ecuador	12:30-2:15 P.M. 7:15-11:15 P.M. daily ex. Monday	6750 44.44 JVT	Nazaki, Japan	(P) Phones JOAK irregular; Phones Point Reyes at times
8185 36.65 PSK	Rio de Janerio, Brazil	(P) Phones LSL-WOK evenings and special programs	6750 44.44 JVT	Nazaki, Japan	2:00-8:00 A.M. irregular
8140 36.86 LSC	Buenos Aires, Arg.	(P) Tests evenings and nights irreg.	6740 44.51 WEJ	Rocky Point, N. Y.	(E) Commercial program service evenings
8120 36.95 KTP	Manila, P. I.	(P) Phones KWX-KWV-PLV-JVQ mornings	6733 44.53 WDA	Rocky Point, N. Y.	(E) Tests evenings irreg.
8110 37.00 ZP10	Aseunzion, Paraguay	8:00-10:00 P.M.	6725 44.60 WQO	Rocky Point, N. Y.	(E) Tests evenings irreg.
8035 37.33 CNR	Rabat, Morocco	Sunday 2:00-5:00 P.M.	6720 44.96 YVQ	Maracay, Venezuela	8:00-9:00 P.M. Saturdays
7970 37.64 XGL	Shanghai, China	(P) Tests early mornings	6701 44.71 TIEP	San Jose, Costa Rica	7:00-10:00 P.M. daily
7968 37.65 HSJ	Bankok, Siam	(P) Tests and phones early A.M.	6680 44.91 DGK	Nauen, Germany	(P) Relays to Riverhead evenings irreg.
7960 37.69 VLZ	Sydney, Australia	(P) Phones ZLT early A.M.	6672 44.96 YVQ	Maracay, Venezuela	(P) Phones and relays N. Y. evenings
7920 37.88 GCP	Rugby, England	(P) Phones VLK irreg.	6650 45.11 IAC	Piza, Italy	(P) Phones ships irregularly
7900 37.97 LSL	Buenos Aires, Arg.	(P) Phones PSK-PSH evenings	6635 45.00 HC2RL	Guayaguil, Ecuador	5:45-7:45 P.M. Sunday. 9:15-11:15 P.M. Tuesday
7880 38.05 JYR	Kemikawa-Cho, Japan	(E) Tests and relays irregularly	6620 45.31 Prado	Riobamba, Ecuador	Thursday 9:00-11:15 P.M.
7860 38.17 SUX	Cairo, Egypt	(P) Phones GCB afternoons	6610 45.38 REN	Moscow, U.S.S.R.	1:00-5:00 P.M. irregular
7855 38.19 LQP	Buenos Aires, Arg.	(P) Tests evening irreg.	6590 45.50 HI4D	Santo Domingo, R.D.	12:15-2:00 P.M. 5:00-8:00 P.M. except Sunday
7797 38.47 HBP	Geneva, Switzerland	5:30-6:15 P.M. Saturdays	6550 45.81 TIRCC	San Jose, Costa Rica	Sunday 11:00 A.M.-1:00 P.M. 6:00-7:00 P.M. 8:00-9:00 P.M. Weekdays 6:00-9:00 P.M. and later
7790 38.49 YNA	Managna, Nicaragua	(P) Phones Cent. & So. America daytime	6520 46.01 YV6RV	Valencia, Venezuela	11:30 A.M.-12:30 P.M. 5:30-10:00 P.M. except Sunday
7790 38.49 HC2JSB	Guayaguil, Ecuador	9:15 A.M.-2:15 P.M. 7:15-11:15 P.M.	6503 46.10 HIL	Santo Domingo, R.D.	Mon. to Sat. inc. 12:15-1:45 P.M. Sat. 7:45-9:45 P.M.
7780 38.56 PSZ	Rio de Janerio, Brazil	(P) Tests LSX early evenings	6490 46.30 HJ5ABD	Cali, Colombia	7:00-10:00 P.M. ex. Sunday
7765 38.63 PDM	Kootwijk, Holland	(P) Special relays to Dutch Indies	6447 46.51 HJ1ABB	Barranquilla, Colombia	11:45 A.M.-1:00 P.M. 5:30-10:00 P.M. ex. Sunday
7715 38.89 KEE	Bolinas, Calif.	(P) Relays programs to Hawaii seasonally	6425 46.69 VE9AS	Fredericton, N.B.	Occasional broadcasts — not regular
7669 39.11 TGF	Guatemala City, Guatemala	(P) Phones TIU-HPF daytime	6425 46.69 W9XBS	Chicago, Ill.	Not regular. Usually Tuesday and Thursday 1:00-5:00 P.M.
7626 39.31 RIM	Tashkent, U.S.S.R.	(P) Phones RKI early mornings	6420 46.70 W3XL	Bound Brook, N. J.	No regular schedule maintained
7610 39.42 KWX	Dixon, Calif.	(P) Phones KKH nights; KAZ-KTP-PLV-JVT-JVM mornings	6415 46.77 HJA3	Barranquilla, Colombia	(P) Phones HJA2 evenings
7565 39.66 KWY	Dixon, Calif.	(P) Phones Shanghai, early mornings	6400 46.88 YN1GG	Managua, Nicaragua	Daily 1:00-2:30 P.M. 7:00-10:00 P.M.
7520 39.89 KKH	Kanluku, Hawaii	(P) Tests KEE evenings; Phones KWX-KWV nights	6385 46.99 TI2GP	San Jose, Costa Rica	8:30-11:00 P.M.
7518 39.90 RKI	Moscow, U.S.S.R.	(P) Phones RIM early mornings	6375 47.10 YV4RC	Caracas, Venezuela	4:30-10:30 P.M.
7510 39.95 JVP	Nazaki, Japan	Tests Point Reyes early A.M.	6350 47.39 JZC	Nazaki, Japan	5:00-7:00 A.M. irregular
7470 40.16 JVQ	Nazaki, Japan	(P) Relays and phones early A.M.	6315 47.50 HIZ	Santo Domingo, R.D.	4:45-5:45 P.M. daily. 10:45 P.M.-12:45 A.M. Sat.
7470 40.16 HJP	Bogota, Colombia	(P) Phones HJA3-YVQ early evenings	6235 48.10 OCM	Lima, Peru	(P) Phones afternoons
7445 40.30 HBQ	Geneva, Switzerland	(E) Relays Special B.C. evenings irreg.	6230 48.00 OAX4G	Lima, Peru	7:00-11:30 P.M. ex. Sunday
7430 40.38 ZLR	Wellington, N. Z.	(P) Phones VLJ early mornings	6198 48.40 CT1GO	Parede, Portugal	Sunday 11:30-1:00 P.M. 7:15-8:30 P.M. Tues. to Fri. inc. 7:15-8:30 P.M.
7400 40.54 WEM	Rocky Point, N. Y.	(E) Special relays evenings	6185 48.50 HI1A	Santiago de Caballeros, R.D.	11:45 A.M.-1:45 P.M. 7:45-9:45 P.M. ex. Sunday
7390 40.55 HJ3ABD	Bogota, Colombia	12 noon-2 P.M. 8:00-11:00 P.M.			
7385 40.62 OEK	Wein, Austria	(P) Tests early evenings very irreg.			
7380 40.65 XECR	Mexico City, Mexico	Sundays 6-7 P.M. Occasionally later			
7370 40.71 KEQ	Kankuku, Hawaii	(P) Relays programs evenings			

KC Meters Call	Location	Time	KC Meters Call	Location	Time
6170 48.62 HJ3ABF	Bogota, Colombia	6:00-11:00 P.M. ex. Sunday	6010 49.92 ZHI	Singapore, S.S.	Mon. Wed. Thurs. 5:40-8:10 A.M. Sat. 10:40 P.M.-1:10 A.M.
6165 48.66 YV3RC	Caracas, Venezuela	10:30 A.M.-1:30 P.M. 4:30-10:00 P.M. except Sunday	6010 49.92 COCO	Havana, Cuba	Sun. 8-10 P.M. Weekdays 10:30 A.M.-1:00 P.M. 4-8:00 P.M.
6150 48.78 HJ5ABC	Call, Colombia	Daily 11:00 A.M.-12 noon; 7:00 P.M.-10:00 P.M.	6006 49.95 HJ1ABJ	Santa Marta, Colombia	11 A.M.-1 P.M. 7-9 P.M.
6150 48.78 HJ2ABA	Tunja, Colombia	1:00-2:00 P.M. & 7:00-10:00 P.M.	6005 49.96 VE9DR	Montreal, Que.	Used very irregular
6150 48.78 CJRO	Winnipeg, Manitoba	Weekdays 7:30 P.M.-12 noon. Sundays 3:00-10:00 P.M.	6005 49.96 VE9DN	Montreal, Que.	Used very irregular
6150 48.78 CQ9GC	Santiago, Cuba	12:00 A.M. Sat.-2:00 A.M. Sunday	6000 50.00 XEBT	Mexico City, Mexico	10 A.M.-12 midnight and later at times
6150 48.78 CSL	Lisbon, Portugal	7:30-8:30 A.M. 2:30-7:00 P.M.	5980 50.17 HIX	Santo Domingo, R.D.	Daily 11:40 A.M.-1 P.M. Tues. & Fri. 8:10-10:00 P.M. Sunday 7:15 A.M.-10:30 A.M.
6140 48.86 W3NK	Pittsburgh, Pa.	9:00 P.M.-1:00 AM. daily	5980 50.17 XECW	Mexico City, Mexico	4-4:45 P.M. 10-12 midnight
6130 48.92 ZCE	Kuala Lumpur, S.S.	Sun. Tues. Fri. 6:40-8:10 A.M.	5969 50.26 HVJ	Vatican City, Vatican	2-2:15 P.M.
6130 48.92 COCD	Havana, Cuba	Sunday 12:00-2:00 P.M. 8:00-10:30 P.M. Weekdays 11:30 A.M. 4:00 P.M. 6:00 P.M.-12 A.M.	5960 50.30 YNLF	Managua, Nicaragua	6-11 P.M.
6130 48.92 LKJ1	Jeloy, Norway	10:00 A.M.-6:00 P.M. daily	5930 50.60 HJ4ABE	Medilhn, Colombia	11 A.M.-12 noon. 6-10:30 P.M.
6120 49.02 W2XE	Wayne, N. J.	7:00-10:00 P.M. daily	5900 50.85 HJ2ABC	Cucuta, Colombia	11 A.M.-12 noon. 6:30-9 P.M.
6120 49.02 YDA	Bandoeng, Java	5:30-11:00 P.M. 5:45-6:45 P.M. 10:30 P.M.-1 A.M.	5900 50.85 HCK	Quito, Ecuador	8:00-11:30 P.M.
6115 49.06 HJ1ABE	Cartagena, Colombia	Sun. 10 A.M.-2 P.M. Mon. 7:30-9:30 P.M. Mon. 11:30 P.M.-12:30 A.M. Sat. 6:00-8:00 P.M. Tues. to Fri. inc. 7:30-9:30 P.M.	5890 50.93 TGX (TG2X)	Guatemala City, Guatemala	11 A.M.-2 P.M. 6-10 P.M. irregular
6112 49.08 YV2RC	Caracas, Venezuela	Daily 11:00 A.M.-1:30 P.M. 4:00-9:30 P.M. Sunday 8:30 A.M. to 10:30 P.M.	5880 51.02 YV3RB	Barguisimeto, Venezuela	6-11 P.M.
6110 49.10 HJ4ABB	Manizales, Colombia	11:00 A.M.-1:00 P.M. 5:00-8:00 P.M.	5853 51.20 WOB	Lawrenceville, N. J.	(P) Phones ZFA afternoons
6110 49.10 VUC	Calcutta, India	Daily 9:30 A.M.-11:00 A.M. 5:00-10:00 P.M.	5850 51.28 YV5RMO	Maracaibo, Venezuela	11:30 A.M.-1 P.M. 5:45-10 P.M.
6110 49.10 VE9HX	Halifax, Nova Scotia	11:30 A.M.-2:00 P.M. 6:00 P.M.-1 A.M.	5845 51.30 KRO	Kaukuku, Hawaii	(P) Tests early mornings
6110 49.10 GSL	Daventry, England	12:15-4:00 P.M. 10-11:05 P.M.	5825 51.50 HJA2	Bogota, Colombia	(P) Phones HJA3 afternoons irreg.
6100 49.18 W9XF	Chicago, Illinois	Daily 12:00 M-1:00 A.M. Tues. Thurs. Fri. Sun. 8:00-9:00 P.M.	5820 51.50 TIGPH	San Jose, Costa Rica	7-10 P.M.
6100 49.18 W3XAL	Bound Brook, N. J.	Mon. Wed. Sat. 5:00 P.M.-12:00 A.M.	5800 51.72 KZGT	Manila, P. I.	(P) Tests mornings irregularly
6095 49.22 CRCX	Bowmanville, Ont.	Thurs. Fri. Sat. 7:00-1:00 P.M. Sun. 12 noon-8 P.M.	5790 51.81 JVV	Nazaki, Japan	(P) Phones JZC early mornings
6090 49.26 VE9BJ	St. John, N.B.	5:00-11:00 P.M.	5780 51.90 HJ1J	San Pedro de Macoris, R.D.	3-9:30 P.M.
6090 49.26 ZTJ	Johannesburg, S. Africa	11:45 P.M.-12:30 A.M. 3:30-7:00 A.M. 9 A.M.-4:45 P.M.	5780 51.90 OAX4D	Lima, Peru	9-11:30 P.M. Wed. and Sat.
6080 49.34 W9XAA	Chicago, Ill.	Daily 10:00 A.M.-6:00 P.M.	5750 52.17 XAM	Merida, Mexico	(P) Phones XDR-XDF early evenings
6080 49.34 ZHJ	Penang, S.S.	6:40-8:40 A.M.	5730 52.36 JVV	Nazaki, Japan	(P) Phones JCZ early A.M.
6080 49.34 CP5	LaPaz, Bolivia	7:00-9:00 P.M. daily	5720 52.45 YV1ORCS	Santo Cristobal, Venezuela	8:00-11:00 P.M.
6070 49.42 VE9CS	Vancouver, B.C.	6:00-7:00 P.M. Sunday. 1:45 P.M.-1:00 A.M.	5712 52.54 CFU	Rossland, Canada	(P) Phones CFO and CFN evenings
6070 49.42 HH2S	Port-Au-Prince, Haiti	Evenings—irregular	5670 52.91 DAN	Nordenland, Germany	(P) Phones ships irreg.
6070 49.42 OER2	Vienna, Austria	9:00 A.M.-5:00 P.M. Saturdays until 6:00 P.M.	5435 53.20 LSH	Buenos Aires, Arg.	(P) Relays LR4 and tests evenings
6070 49.42 HJN	Bogota, Colombia	6:00-10:45 P.M.	5400 55.56 HJA7	Cucuta, Colombia	Phones irregularly. Broadcasts music in evening at times
6065 49.45 HJ4ABL	Manizales, Colombia	11:00 A.M.-12 noon Sat. to 5:30. 7:30 P.M.-10:30 P.M.	5400 55.56 HJA7	Cucuta, Colombia	Monday 4-8 P.M.
6060 49.50 W8XAL	Cincinnati, Ohio	5:30 A.M.-7:00 P.M. 10:00 P.M.-1:00 A.M.	5265 57.00 KEC	Bolinas, Calif.	(P) Phones Honolulu irregularly
6060 49.50 W3XAU	Philadelphia, Pa.	7:00 P.M.-10:00 P.M.	5170 58.50 PMY	Bandoeng, Java	(E) Phones and relays programs early mornings
6060 49.50 VQ7LO	Nairobi, Kenya Colony, Africa	5:45-6:15 A.M. 11 A.M.-2 P.M.	5080 59.08 WCN	Lawrenceville, N. J.	(P) Phones GDW evenings seasonally
6060 49.50 OXY	Skamleback, Denmark	1-6:30 P.M. Sunday 11 A.M.-6:30 P.M.	5025 59.76 ZFA	Hamilton, Bermuda	(P) Phones WOB evenings
6050 49.59 GSA	Daventry, England	6-8:05 P.M.	4975 60.30 GBC	Rugby, England	(P) Phones ships afternoon and nights
6043 49.65 HJ1ABC	Barrinquilla, Colombia	12 noon-1 P.M. 6-10:30 P.M.	4905 61.15 CGA8	Drummondville, Que.	(P) Phones GDB-GCB afternoons
6040 49.67 HJ4ABC	Pereira, Colombia	9:30-11 A.M. 7-9 P.M.	4820 62.20 GDW	Rugby, England	(P) Phones WCN-WOA evenings
6040 49.67 PRA8	Pernambuco, Brazil	9:30-11:30 A.M. 2:30-8:30 P.M.	4752 63.13 WOY	Lawrenceville, N. J.	(P) Tests very irregular
6040 49.67 W4XB	Miami, Florida	Weekdays 12-2 P.M. 5:30 P.M.-12 A.M. Sunday 11:30 A.M.-3 P.M. 5 P.M.-12 A.M.	4752 63.13 WOO	Ocean Gate, N. J.	(P) Phones ships irreg.
6040 49.67 W1XAL	Boston, Mass.	Tuesday & Thurs. 6-9:00 P.M. Sundays 5-7:00 P.M.	4600 65.22 HC2ET	Guayaquil, Ecuador	9:15-10:45 P.M. Wed. and Sat.
6030 49.75 HP5B	Panama City, Panama	12 noon-1 P.M. 8-10:35 P.M.	4555 65.95 WDN	Rocky Point, N. Y.	(P) Tests Rome and Berlin evenings
6020 49.83 DJC	Zeesen, Germany	12 noon-4:30 P.M. 9:30-10:45 P.M.	4510 66.52 ZFS	Nassau, Bahamas	(P) Phones WND daily; Tests GYD-ZSV irregular
6020 49.83 CQN	Macao, China	Monday & Friday 3-5:00 A.M.	4348 69.00 CGA9	Drummondville, Que.	(P) Phones ships and Rugby evenings
6012 49.85 HJ3ABH	Bogota, Colombia	11:30 A.M.-2 P.M. 6-11 P.M. Sunday 4-9 P.M.	4320 69.40 GDB	Rugby, England	(P) Phones CGA8 and tests evenings
			4295 69.90 WTDV	St. Thomas, Virgin Is.	(E) Weather reports 2-3 P.M.
			4295 69.90 WTDW	St. Croix, Virgin Is.	(E) Weather reports 2-3 P.M.
			4295 69.90 WTDX	St. John, Virgin Is.	(E) Weather reports 2,3 P.M.
			4272 70.20 WOO	Ocean Gate, N. J.	(P) Phones ships afternoons and eve.
			4272 70.20 WOY	Lawrenceville, N. J.	(P) Tests and phones ships evenings
			4250 70.65 RV15	Khabarovsk, U.S.S.R.	1:30-9:00 A.M.
			3770 79.60 HB9B	Basle, Switzerland	Mon. Thurs. Fri. 4-6 P.M.

BOSCH MODEL 575

(Continued from page 83)

should be reduced—at the input of the receiver. No doubt this unit accounts for the rather good sensitivity of the receiver.

Results of Tests

Atmospherics were too strong to pick up KFI in the broadcast band, but the rest of the country was pretty well accounted for. Stations in Canada and Mexico were also brought in.

All bands were tested for dead spots and image reception. None. The automatic volume control took hold well on most signals and, unlike the AVC systems in some sets, held strong signals within bounds.

On the short-wave bands, Italy and Rio came in, in fine fashion, but London on three bands and Berlin on two bands didn't show up well until later in the week. VK2ME was hauled in with moderate signal strength on a Sunday morning. The 49-meter band brought up almost the entire flock of Central and South-American stations, and also Portugal.

Conditions on the 20-meter amateur band were reported as being rather poor, so we took a fling in that band to see what the Bosch set could do under adverse conditions.

A load of 4's, 5's and 9's were hauled in; also a few 2's and the following 6's and 7's: W6AXT, W6DDA, W6QQG, W7AOF, and W7BCI.

The following foreign amateur phone stations were logged: X1G, X1AG and X1HH, Mexico; CO2SB, CO2AM, 2LL and 8YB, Cuba; HH5PA and HI7G, Haiti and Dominica; VP5PZ, Jamaica; PY1GK, Brazil; TI2RC, Costa Rica; CX2HK, Uruguay, and F8DR, France.

JNB and JNJ—both code stations—were picked up slightly off the 20-meter amateur band.

South Norwalk, Conn. Sept. 15th.

BROADCASTING MOVES AHEAD

(Continued from page 55)

equipment because sets were not capable of reproducing the highest broadcast quality, are now erecting new transmitters, to keep in step with reception advances.

With many brilliant new radio features in prospect and with better listening available, a banner radio season is anticipated. Improved conditions and greater public buying power lead the manufacturers to predict a boom season in radio set sales. Those who replace sets used for several years may expect a surprise when they experience the new perfection of quality which many of the new sets feature.

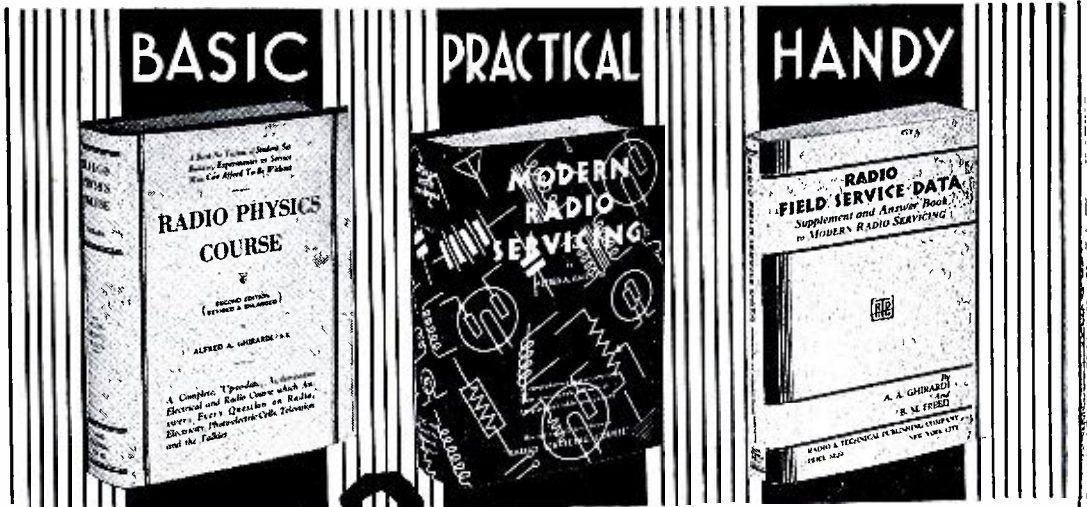

8 solid pounds of radio information

RADIO PHYSICS COURSE

by A. A. Ghirardi
972 pages. Over 500 illustrations. 856 Review Questions. Price \$4.00.

MODERN RADIO SERVICING

by A. A. Ghirardi
1300 pages. 706 illustrations. 723 Review Questions. Price \$4.00.

RADIO FIELD SERVICE DATA

by A. A. Ghirardi and B. M. Freed
240 pages. 41 illustrations. Flexible binding. Price \$1.50.

Introductory Combination Offer
Modern Radio Servicing and Radio Field Service Data
\$5
Only if Purchased Together

SHORT WAVE RADIO HANDBOOK

by Clifford E. Denton
Denton has done it! Into a handy well-illustrated book filled to the brim with data, he has condensed all his years of short wave experience to give you the really important dope that will help you most. The receivers and oscillators described here were built specially for this book. His construction details are truly invaluable. Here are just a few of the many features:
Complete coil-winding data for all size forms and condensers; wire table for both solid and litz; dope on A-F amplifiers; R-F systems; band spreading, superhets, single-signal receivers, electron-coupled oscillators, etc., etc.
More dope on earphones, magnetic speakers, dynamic speakers, baffles and horns, loud-speaker coupling systems, power sensitivity of out-put tubes, detector circuits, antenna circuits, reflex circuits, power supply units, etc.
128 pages. Over 150 illus. \$1.00.

Everything you need to know

1. These three Ghirardi books are so important for you that you should not go another day without seeing them. Together they give in clearly understandable form every particle of radio knowledge and data that you will need for a long time to come. No matter whether you are student, amateur, technician or engineer—if you have any interest in radio these books are the foundation of your library.

2. Ghirardi's RADIO PHYSICS COURSE, now in its 2nd revised edition, has long been the best-selling general text on radio all over the world. It is absolutely complete—everything from fundamental electrical theory right down to the latest applications in television and the talkies.

3. Ghirardi's MODERN RADIO SERVICING, although out only a few months, has called forth so much unsolicited praise from practical service men that we are conservative when we say it is not only the best book in this field, but the only practical book that covers it thoroughly and gives so much essential information. You'll find described here every kind of testing instrument and method—all the latest dope on Cathode-Ray Oscilloscopes, etc. Everything connected with servicing is here—alignment of receivers, elimination of noise and interference, auto radio, etc., etc.—even to a long chapter on how to sell and advertise your service.

4. Ghirardi and Freed's RADIO FIELD SERVICE DATA AND ANSWER BOOK is the Supplement to MODERN RADIO SERVICING to take with you out on your servicing jobs. It has tabulated data of all kinds arranged for immediate reference—trouble symptoms and remedies for over 750 receivers, a complete table of intermediate frequencies for all superhets (2,790 in all!) and 25 other useful tables and charts.

5. You need all three of these books right now. The day you get them you'll be able to do your radio work quicker and better—and to do many things you never could before. They'll put hundreds of new ideas into your head and new money into your pocket! Get your copies now

"The Gadget"

Almost every wide-awake service man in the country has one of Ghirardi and Freed's handy little Trouble-Shooting Gadgets that gives you 275 remedies for every type of symptom. Get yours today and keep it with you all the time. It's only a quarter!



Send Now For FREE Circulars

To Radio & Technical Publishing Co., 45 Astor Place, New York, Dept. AW-11

Please send free circulars mentioned in A L L - W A V E RADIO.

Please send copies of RADIO PHYSICS COURSE, at \$4. each postpaid.

Please send copies of MODERN RADIO SERVICING, at \$4. each postpaid.

Please send copies of RADIO FIELD SERVICE DATA, at \$1.50 each postpaid.

Please send your Combination Offer of the above two books, at \$5. postpaid.

Please send of your Trouble-Shooting "Gadgets" at 25c each postpaid.

Please send copies of Denton's SHORT-WAVE HANDBOOK, at \$1. each, postpaid.

Name

Address

Occupation

Lafayette

PROFESSIONAL "9" Communication Receiver

Now every amateur can afford an up-to-the-minute receiver that incorporates every modern feature which contributes to better performance.

The low price of this remarkable receiver is due solely to the fact that the amateur is required to build part of the job himself thus saving labor cost. Yet, despite the fact that Lafayette engineers have designed a precision instrument, it is nevertheless very simple to assemble. This is because the coil switching assembly comes from the factory already wired and tracked.

Five separate wave bands are provided including the 10 meter band. Thus, not only are amateur broadcasts available but also all other short wave broadcasting bands and the American broadcast band.

The Lafayette Professional "9" tube amateur superheterodyne kit comprises all parts including speaker but less tubes and cabinet. For use on 50-60 cycles, 110-125 volts. Complete instructions and diagrams are furnished. Our low price\$37.75

For kit of 9 matched tubes, add \$4.54; for metal cabinet as illustrated, add \$7.50. If wanted completely wired add \$7.50.



FREE!

1936 Catalog

of 196 pages lists every last minute development in radio. The largest and most all inclusive array of radio merchandise ever offered by one company. Lists all wave and short wave receivers, kits, tubes, parts and accessories as well as X'mitting equipment and public address equipment . . . all at lowest WHOLESALE Prices. Get your copy today.

NOTE THESE FEATURES

- ★ Includes 5 Amateur Bands Within Its Range.
- ★ Stage of Radio Frequency Amplification on ALL Bands.
- ★ Coil-Switch Unit Completely Assembled, Wired, Tracked.
- ★ Beat Frequency Oscillator For C. W. Code Reception.
- ★ Automatic or Manual Volume Control at Will.
- ★ New Oscillator Using Power Pentode Tube.
- ★ Continuous Mechanical Band Spreading Feature.
- ★ Dual Speed Airplane Tuning Dial with Second Hand.
- ★ Complete Detailed Instructions Make it Easy to Build.
- ★ Demountable Power-Speaker Unit.
- ★ Black Crystalline Finished Cabinet Available.

Wholesale Radio Service Co.
100 Sixth Avenue, Dept. AR-115
New York, N. Y.

- I enclose \$.....for order described in attached letter.
- Send me your new 1936 Catalog \$59.
- Name
- Address
- CityState

WHOLESALE RADIO SERVICE CO.
NEW YORK, N.Y.
100 SIXTH AVE.
CHICAGO, ILL. 901 W. JACKSON BLVD.
ATLANTA, GA. 430 W. PEACHTREE ST. N.W.

CHANNEL ECHOES

(Continued from page 85)

It should only be necessary to point out to these Senators that May Day is the first of May—an anniversary of international significance, celebrated in every country of the world by the Communists as their Fourth of July. Congress will immediately sense the sinister workings of the Kremlin, the undercurrent of Stalin's machinations that resulted in this phrase being accorded world-wide publicity—under the very noses of the representatives of non-communicistic nations, at the Madrid conference! A new conference will be instigated. "M'adier" will be changed to something less crimson—such as, "Oh yoo-hoo"—and we shall have cleared up short-wave broadcasting allocations—maybe.

SPY CHASER

(Continued from page 82)

and had to explain who they were and why they had a car full of radio equipment. One over-zealous chief of police refused to take any credence at all in their story. He said he had heard and read about how these smart German spies worked and they could not fool him, no sir.

"How did you get out of that one?" we asked Sayres.

"We didn't," was the reply. "That low-comedy cop absolutely wouldn't believe our credentials. He had been warned about spies with a radio set in their car and now that he caught 'em, he was going to keep them. And he did. He put us in separate cells, took all our papers away from us and refused to let us telephone headquarters. Hours later, he sent one of his cops to bring us before him and from the way he had raved it wouldn't have surprised me a bit to have had him announce that he had decided to have us shot at sunrise.

"Well, when we were lined up before his desk, he started apologizing and we knew that he had come to his senses and called the Navy Yard in New York. We found out later that he had gone around telling all his friends that he had made a big spy haul, and I'll bet he expected some medals for his detective work. But you know, even though I was sure we would get out of there all right, I had a mighty uncomfortable feeling being shoved in the hoosegow the way we were."

"But how about the spies?" we reminded Sayres. "Did you finally catch up with them? And were they really spies?"

"Yes, we got them and they were indeed German spies. They had mounted their transmitter in a small, fast delivery truck with no name on the side

panels. It was as sweet an outfit as I had ever seen and those boys sure did know their stuff, when it came to dodging us. We never found out much about them, but they all spoke perfect English and when once we had them cornered they never put up a bit of a scrap. They came along quietly with us and I heard were sent to an internment camp for the duration of the war."

"Spy hunting certainly doesn't sound as exciting as some novelists would have us believe," we remarked. "Didn't you have any gun-fights or anything like that?"

Sayres shook his head.

"Sorry to disappoint you, but we didn't. Most of the cases I looked up were reported to us because the person had a German name or because some neighbor had a grudge against him or for some other equally simple reason. Of course, as far as we knew any one of the hundreds of cases I investigated might have been a spy and we just couldn't take a chance that it was another false alarm.

"When a country is at war," he went on, "the people as a whole are in a strange state of mind. They are apparently only too ready to believe the worst about a person, and often quite wrongly. I remember one case in particular that was really quite sad. A family, whose son was a radio operator on board a freighter that had been torpedoed by the Germans, had a Dutch name and so was checked up by the Intelligence. I got in on the case through checking up on the son, who was one of the very few that had been saved from the freighter before she sank. The whole family was eventually given a clean bill and the case dropped. However, about ten years later I met that boy, who told me that he and his family had had to move away from that small town in which they had lived for years, because their neighbors refused to have anything to do with them, after they had been investigated.

"Certainly all cruelty in war times isn't confined to the war zone, is it?"

MODERN RADIO SERVICING

By Alfred A. Ghirardi, published by the Radio and Technical Publishing Co., 45 Astor Place, New York City, N. Y., 1300 pages, 706 illustrations, price \$4.00.

Modern Radio Servicing is really a second edition of *Radio Servicing Course*, but a rather large one, for the new edition contains 1300 pages in comparison to 182 pages for the preceding book. In planning this new volume the general style of the first issue was retained, and many additional chapters covering new topics were added.

This book has been divided into four parts. Part I has seventeen chapters de-

voted to the theory and construction of modern radio test equipment. The nine chapters of the second part are given over to the practical servicing of radio receivers. The third section of the book contains six chapters on specialized servicing problems, while the last part deals with vacuum-tube charts.

Part I begins with a four-page introduction and follows it with chapters on the theory of "Milliammeters, Ammeters, and Voltmeters" and "Methods and Instruments for Measuring Resistance." The remaining pages of this section are concerned with ohmmeters, condenser testers, capacity meters, output meters, vacuum-tube voltmeters, tube checkers, voltage-current set analyzers, point-to-point testing, and test oscillators. Data is included on commercial types as well as the types which may be built up by the Service Man.

Chapter titles of Part II are as follows: "Preliminary Tests for Trouble," "Peculiarities of avc and qvc circuits," "Receiver Analysis by Voltage-Current Tests," "Receiver Analysis by Resistance Tests," "Testing Individual Radio Components," "Obscure Troubles Not Revealed by Analyzers," "Aligning and Neutralizing t-r-f Receivers," "Aligning and Neutralizing Superheterodyne Receivers," and "Repairing Individual Radio Components."

The third section covers the installation and servicing of auto-radio and marine receivers, and the servicing of all-wave receivers. The remaining chapters are entitled: "Reducing Electrical Interference," "High-Fidelity Receiver Problems," and "How to Sell Your Service,"

Review questions are given at the end of nearly all the chapters, the total number being 723. Also, a complete, cross-referenced index has been included.

Modern Radio Servicing is a practical text on the theory, construction, and use of modern radio service equipment, and the rapid and systematic methods of radio servicing.

LAFAYETTE NINE

(Continued from page 68)

and the picture layout diagram, in an effort to make absolutely sure that you have everything in its proper place, and properly connected into the circuit. After you are sure that this is the case, the receiver should be air tested, and the intermediate - frequency transformers aligned, using a broadcast signal for this purpose, if a calibrated oscillator is not available. The intermediate frequency employed is 470 kilocycles.

Mounting Chassis

The appearance of the front panel, which is equipped with two brackets will make it quite apparent how the chassis is to be mounted. Of course, it will be nec-

essary to remove all of the knobs from the controls, as well as one washer, and one nut from the headphone jack. It is now only necessary to slide the chassis in between the two brackets, until the holes in the brackets line up with the holes in the bottom of the chassis. The 6/32 screws provided should then be employed to fasten the chassis in this position.

Additional Hints

The grid leads of the first r-f and first detector tubes, are taken from the stator lugs of the variable condenser above the chassis, and at almost the same height as the grid caps of the tubes will be, while the return wiring is taken from the other side of the condenser, from the other stator terminal.

Make all leads as short and direct as possible, with the exception of the leads mentioned in the text, that are to be kept away from the chassis.

The beat-frequency oscillator coupling condenser should be left almost all the way open, or at its minimum capacity setting, until you have the rest of the receiver properly aligned and are obtaining satisfactory performance. Upon throwing the switch to the beat-frequency oscillator position, the BFO tuning lever should be adjusted for maximum hiss or rush, which is usually quite noticeable. If, upon tuning into a cw signal or some other carrier, the beat produced is not loud enough, the coupling condenser may then be adjusted for additional BFO signals.

Do not attempt to wire the receiver from the schematic diagram only, for as mentioned above, the various ground points and the location of several leads is very important, and in view of this, the picture diagram should be adhered to closely.

There are only two shielded leads employed in the entire receiver, one being the audio grid lead to the 6D6 first audio stage, and the other, the plate lead of the first detector.

When mounting the loudspeaker, the speaker should be fastened to the panel first, and then the chassis slid forward towards the panel, until the holes in the brackets and the chassis line up. It is also advisable to mount the dial escutcheon plate along with the loud speaker.

(Results of the tests made on this receiver will appear in the "Radio Proving Post" next month.—Ed.)

SHORT-WAVE UNIVERSITY

SHORT-WAVE listeners with a thirst for education may tune in on a wide variety of courses offered by the International University of the Air, over WIXAL, Boston, (6040 or 11,790 kc) every Tuesday and Thursday, 7:15 to 9:15 P. M., E.S.T.

Amazing New 1936 Super Deluxe METAL TUBE MIDWEST 18-Tube 6-BAND RADIO



Everywhere, radio enthusiasts are praising this amazingly beautiful, bigger, better, more powerful, super selective, 18-tube 6-tuning range radio. This super Midwest will out-perform \$200 to \$300 sets on a point-for-point comparison. Before you buy any radio, write for FREE 40-page 1936 catalog.

30 DAYS FREE TRIAL
TERMS AS LOW AS \$5.00 DOWN
ONLY RADIO COVERING 4 1/2 TO 2400 METERS
PUSH-BUTTON TUNING
ONLY RADIO WITH 6 TUNING RANGES
NEW ACOUSTI-TONE
FULL-SCOPE HIGH FIDELITY
3 ONE-YEAR GUARANTEES

\$59.50 WITH NEW GIANT THEATRE SONIC SPEAKER (LESS TUBE)

80 Advanced 1936 Features
 Scores of marvelous features, many exclusive, explain Midwest super performance and thrilling world-wide all-wave reception... enable Midwest to bring in weak distant foreign stations, with full loud speaker volume, on channels adjacent to locals. Thrill to Full Scope High Fidelity and brilliant concert tone. Every type of broadcast from North and South America, Europe, Asia, Africa and Australia is now yours. Send today V-Front Design for money-saving facts. (Patent Pending)

Deal Direct With Laboratories
 No middleman's profits to pay—you buy at wholesale price direct from laboratories... saving 30% to 50%. Increasing costs mean higher prices soon. Take advantage of Midwest's sensational values. As little as \$5.00 down puts a Midwest in your home on 30 days free trial. You are triply protected with Foreign Reception Guarantee, Parts Guarantee, Money-Back Guarantee!

SAVE UP TO 50%

MAIL COUPON TODAY! FOR FREE 30-DAY TRIAL OFFER and 40-PAGE FOUR-COLOR FREE CATALOG

MIDWEST RADIO CORP., Dept. 128N, Cincinnati, Ohio

Without obligation on my part, send me your new FREE catalog, complete details of your liberal 30-day FREE trial offer, and FREE Miniature Rotating 18-tube Dial. This is NOT an order.

Name.....

Address.....

Town..... State.....

Check if interested in an All-Wave Battery Radio

User-Agents Make Easy Extra Money Check Here for details



FRANKLIN STUDIOS
 offers a complete
Advertising Display Service—Re-style and Coordinate
 your
 Boxes, Cartons, Counter Displays, Car Cards, etc.

FRANKLIN STUDIOS
 135 W. 25th Street
 New York City

BACKWASH

(Continued from page 86)

all the Ham bands, and the F. C. C. is cracking down. Your chances of ever getting a license are slim if you start off by bootlegging.

Would like to communicate with any amateurs working the 40-meter band who would like to help with some traffic with the West Coast and Spain. If you want a good rag chew, listen for me on 7160. I'll be only too glad to have a QSO with you.

ROBERT O. SLEMMER, W3ETE
CUMBERLAND, MD.

How do you like the Ham stuff in this issue? More on the way. Potential Hams—take the advice of 3ETE and don't go on the air without a license. Some people have gained the idea that it isn't necessary to have a license for transmitting on 5 meters. We don't know where this story was started—but just keep in mind that a license is required for any type of radio transmitter. So, keep your nose clean.—Ed.

THE MASTERPIECE IV

(Continued from page 77)

three-section Litz wound coils each tuned by a 100-mmfd air condenser. Both coil and condenser insulation is isolantite. Again large shields 3" in diameter and 4 11/16" high are used to insure no impairment of the efficiency of these very excellent tuned circuits.

High Fidelity

The admission, amplification and final reproduction of the frequency band of 30 to 9000 cycles necessary to full-range, high-fidelity reception seems relatively simple at first glance. Some of the problems are not as simple.

One of the first problems is broadcast stations themselves. Some are good and many are bad. Some modulate up to 10,000 cycles, and some don't go up to 5,000 cycles, but the designer's task is to make them all sound perfect. In the course of design work, when everything in the receiver seems okay, and a local station is tuned in, quality is ragged and poor, so the station is blamed. But a checkback on the station itself, if it should be made, says the station quality is good. So the search for perfection again goes forward, and finally reproduction is obtained for which no excuses of poor station quality need be made.

This explanation is offered because many high-fidelity receivers are being offered with excuses as to poor quality on some stations, or on all stations at some times of the day, which are really excuses for poor receiver reproduction. As a result of most careful design, no such excuses need be made for the Masterpiece IV. It will reproduce without "sta-

tion distortion" the programs of any good station, day or night, network or local origin, with good undistorted quality limited only by the strength of the station (local or semi-distant) and the tone range it may be covering at the time (few network programs go above 5,000 to 6,000 cycles today, and usually only locally originated programs will go up to 9,000 cycles.)

GLOBE GIRDLING

(Continued from page 64)

P. M. E.S.T. over League of Nations station HBL (9505), HBP (7797), HB9B (14,236), and HB9AT (14,290). Correct reports will be verified. Send reports to Secretary of above organization. HRN, Tegucigalpa, Honduras, 5870 or 5875 KC, reported heard around 10 P. M. Signs off with "Good Night Melody."

Quixite Radio Club in late report shows HJ4ABD, Medellin, Colombia, testing out in evening on 6060 KC; 49.50 meters. Also HJ4ABJ, Ecos del Combrima, Ibagne, Colombia, on about 6460 KC, or 46.44 meters.

Mr. Wilfred T. Siddle, Birmingham, Ala., says he is hearing a station on 6040 KC or 49.67 meters with call of HRP1, known as "Ecos de Honduras," around 7:30 P. M. E.S.T. and located at San Pedro Sula, Honduras, and that he has received verification to his report.

One needs a super-selective set to pull them out of the 49-meter band with its additions and continual changes.

Reports From Readers

In conclusion, may I extend a cordial request that my readers send me reports of their own receiving experiences, changes in time schedules, errors noted, etc., with a view to improving this section of ALL WAVE RADIO. It affords me personal pleasure in replying to your letters, exchanging ideas and assisting where I can.

I do not claim to be the foremost authority on the subject of distance reception, yet I believe my long experience in radio receiving, its conditions, and my close touch with the situation in general, will be of assistance in furnishing you the information you desire.

I would much prefer to have you feel that I am one of you and to gain your confidence and esteem by giving you as reliable information as is possible to give at all times. I have made many warm friends in radio in my contact with it and wish not to lose them, for "all the wealth of the world could not buy you a friend or pay you for the loss of one." And friends are not made or retained through misrepresentation or endeavoring to create an impression that you are superior to those with whom you work.

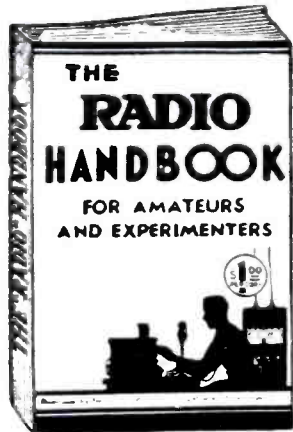

Largest Sale of Any Book
of its Kind in the World

THE "RADIO" HANDBOOK

The Absolute Technical Authority
for the Amateur and Short-
Wave Experimenter

ONLY \$1.00 PER COPY

● Tells how to build any kind of a short-wave or amateur Receiver from a 1-tube to a 12-tube crystal superhet. . . . how to build any kind of a radio-telephone or c.w. transmitter from a 5-watt to a kilowatt. 64 pages of 5-meter radiotelephony data. 48 pages of new data on best antenna systems. Many chapters of the new electron theory of radio and electricity. Tells how to master the radio code, how to get a license. 300 pages. Hundreds of marvelous illustrations. Sent post-paid, anywhere, for only \$1.00 per copy.

ORDER

"RADIO," 422 Pacific Bldg.,
San Francisco, USA.

Here is \$1.00. Send me the new
1936 Edition of the great Handbook by
"RADIO."

Name

Street & Number

City & State

We've made our bow
and



We're glad you liked
our first issue



You'll want to receive
every issue early

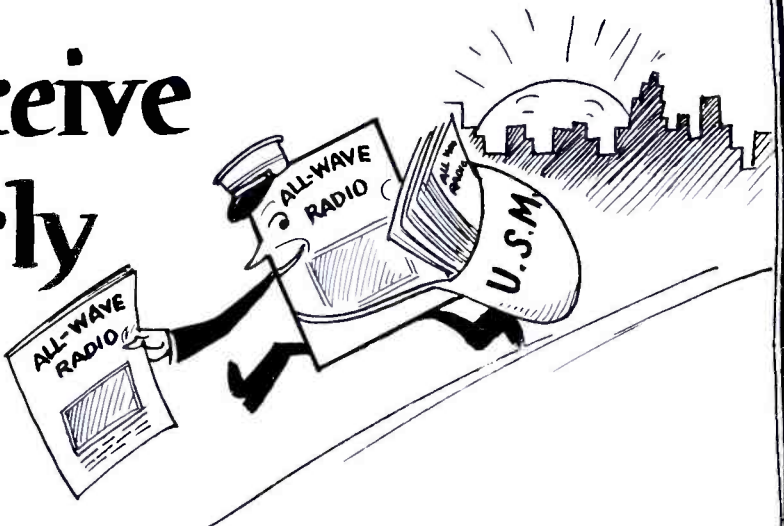

12 MONTHS
Subscription

\$1.50 in U.S.A.
\$2.00 in Canada

ALL-WAVE RADIO

200 FIFTH AVE. NEW YORK CITY

GENTLEMEN: Enclosed please find \$1.50 M.O. CASH CHECK
for 12 Months subscription . .

Don't Let a Poor Aerial Spoil Otherwise Excellent Reception

The BEST Costs No More!

Why Be Satisfied with Imitations?

As a result of LYNCH pioneering in the Aerial Field, many hundreds of thousands of antennas have been sold. But LYNCH HI-FI Antennas still maintain their superiority—technically, mechanically and electrically.

There's a Reason!

Competitors have copied the fundamentals of noise-free aerials, but they cannot duplicate LYNCH PERFORMANCE.

LYNCH HI-FI Antennas are *Patented* and *Guaranteed*.

NOISE-REDUCING TWINS

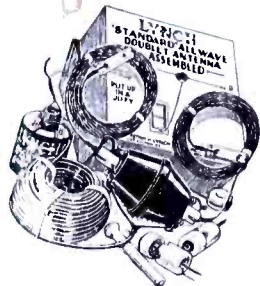

LYNCH HI-FI ASSEMBLED ANTENNA

All ready to hang. Saves 90% of installation time. Any novice can install it—quickly, easily, correctly. Makes every set perform better on ALL waves. Results are **\$6.75** List
amazing.

**The ONLY Two Companion Devices
For Reducing Noise on ALL Waves!**

LYNCH FILTERADIO

Cuts out objectionable noise from the light line, consumes no current. Makes interference from circuit breakers, motor generators, etc., practically negligible.

Easy to install; simple to adjust. One type serves all purposes. **\$5.00** List

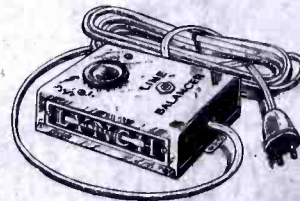

[A 40% discount is allowed to members of the I. S. W. C.]
[If local jobber or dealer cannot supply you, order direct.]

ARTHUR H. LYNCH, Inc., Dept. A.W., 227 Fulton St., New York, N. Y.
PIONEER OF NOISE-REDUCING AERIALS