



Welded Steel Pipe

Design Manual
2007 Edition

**Merits, Design Standards,
Technical Data and References**

In cooperation with, and
editorial collaboration by



Acknowledgements

The American Iron and Steel Institute wishes to acknowledge, with appreciation, the contributions made by past and present members of the STI/SPFA Pipe Committee. Special thanks are given to Robert Card, Victaulic, Inc.; Dennis Dechant and Bruce VanderPloeg, Northwest Pipe Co.; Brent Keil, Continental Pipe Mfg.; George Ruchti, American Spiral Weld Pipe Co.; and George Tupac, Consultant, for assistance in providing this manual. The Committee is grateful for the expert assistance of Professor Emeritus Reynold K. Watkins, Utah State University, for his contribution to the new structural analysis section. Photographs used in this volume are courtesy of Victaulic, National Welding Corp. and STI/SPFA (Steel Tank Institute/Steel Plate Fabricators Association).

Inquiries regarding copies of this publication may be directed to the above companies, or to:

American Iron & Steel Institute
1140 Connecticut Avenue, NW
Suite 705
Washington, DC 20036
(202) 452-7100
www.steel.org

STI/SPFA
570 Oakwood Road
Lake Zurich, IL 60047
(847) 438-8265
www.steeltank.com
www.spfa.com

Welded Steel Pipe Design Manual

Merits, Design Standards, Technical Data
and References

A compilation of useful information for the design of water transmission lines
and distribution systems using welded steel pipe.

Publication Number D631-0807-e

Published by
AMERICAN IRON AND STEEL INSTITUTE

In cooperation with, and editorial collaboration by, STI/SPFA
(Steel Tank Institute/Steel Plate Fabricators Association).

The material presented in this publication is for general information only and should not be used without first securing competent advice with respect to its suitability for any given application. The publication of the material contained herein is not intended as a representation or warranty on the part of American Iron and Steel Institute — or of any other person named herein — that this information is suitable for any general or particular use or of freedom from infringement of any patents. Anyone making use of this information assumes all liability arising from such use.

Table of Contents

	Page
Welded Steel Pipe	1
Research and Development	2
History of Steel Pipe	3
Search for Strength and Durability	3
Long Service Records	5
Future of Welded Steel Pipe	5
Properties of Steel Pipe	6
1. Strength	6
2. Ease of Installation	6
3. High Flow Capacity	6
4. Leak Resistance	7
5. Long Service Life	7
6. Reliability and Versatility	7
7. Economy	8
8. Conclusions	9
Materials	11
Structural Analysis of Buried Pipe	12
Design and Analysis	12
Performance Limit	13
Notation and Nomenclature	14
General Analyses	15
1. Internal Pressure	15
2. Handling and Installing	16
3. Ring Stability	17
4. Maximum Height of Cover for Pipe Held Round	20
5. Minimum Height of Cover	20
6. Longitudinal Stress Analysis	21
7. Ring Deflection	21
8. Allowable Ring Deflection	22
9. Backfill and Embedment Specifications	23
Specific Analyses	23
Pertinent Variables	23
Performance Limits	25
Design for Internal Pressure	26
Handling	27
F-Load at Yield Stress	27
Ring Deflection at Yield Stress, due to F-Load	27
Soil Mechanics	28
Soil Stresses	28
Pipe Mechanics	32
External Pressures and Loads	33
1. Ring Compression Stress	33
2. Ring Deflection	34
Ring Stability	36
1. Without Soil Support	36

Table of Contents (continued)

	Page
2. With Soil Support and No Water Table or Vacuum	37
3. With Soil Support and Vacuum, Unsaturated Soil	39
4. With Soil Support, Water Table Above Pipe, Saturated Soil	40
Flotation	42
Minimum Soil Cover	42
Trench Conditions	44
Trench Shield	44
Trench Width	45
Parallel Trench	47
Embankment Over a Pipe	48
Parallel Pipes	48
Longitudinal Analysis	50
1. Thrust Restraint	50
2. Longitudinal Contraction	51
3. Beam Action	52
4. Buried Pipe on Piles	52
Backfilling	53
1. Water Compaction	53
2. Mechanical Compaction	54
3. CLSM	54
Compound Stress Analysis	54
1. Huber-Hencky-von Mises Equation	55
2. Stresses at Mitred Bends	55
Strength of Field Welded Joints	57
The Effect of Mortar Linings and/or Coatings on Ring Stiffness	58
Plastic Analysis	60
Measurement of Radius of Curvature	61
Crack Width Analysis	61
Flowable Fill	62
Requirements of the Embedment	64
Flowability	64
Vertical Compressibility	64
Bearing Capacity	64
Inspection	64
Test Results	64
Conclusions	65
Linings and Coatings	66
Introduction	66
Exterior and/or Interior Systems	66
AWWA C-203	66
AWWA C-205	67
AWWA C-210	67
AWWA C-222	67
Exterior Systems	68
AWWA C-209	68

Table of Contents (continued)

	Page
AWWA C-214	69
AWWA C-216	69
AWWA C-218	69
Interior Systems	69
AWWA C-602	69
Coating Application	70
Joints	71
Bell and spigot joints with rubber gaskets	71
Welded lap joints	71
Welded butt joints	72
Butt-strap joints	72
Mechanical couplings	73
Split-sleeve couplings	73
Flanged Joints	74
Appendix A	75
Useful Publications	79
Standards and Specifications	80
Appendix B	81



Welded Steel Pipe

During the 20th Century, advancements were made in steel pipe — in the economy of production and the quality of the product. Noteworthy are the machines and technology for cold-forming of flexible pipe from coils of sheet steel with automated spiral welds. Great strides were made in quality control, testing, joints and protective coatings. Welded steel pipe is available in wide ranges of sizes and properties of the steel. Included in this manual are the design criteria for steel pipe up to 240 inch (6,000 mm) in diameter under either internal or external pressure. The requirements of buried flexible pipe are: strength, ease of installation, high flow capacity, leak resistance, long service life, reliability and versatility, and economy. The properties of steel are well adapted to these seven requirements of buried pipelines. An explanation of each requirement is found in *Properties of Steel Pipe*, page 6.



Research and Development

STI/SPFA — comprised of two divisions, Steel Tank Institute and Steel Plate Fabricators Association — has served water, food, petroleum and chemical markets since 1916 as developers of standards and certification programs for quality, safety and reliability in the manufacture, installation and testing of steel tanks, piping and pressure vessels. Leading North American producers of steel pipe and pipe-protection materials collaborate with pre-eminent pipeline engineers as members of STI/SPFA. The association and its members sponsor research, and maintain facilities that perform research, on metallurgy, welding, joints, pipe linings and coatings. New product developments and improvements in manufacturing processes are frequently under study. In addition, representatives of STI/SPFA and their members serve on committees engaged in the preparation of national codes, standards and specifications for the design, installation and operation of steel tanks and pipelines.

The American Iron and Steel Institute (AISI) serves as the voice of the North American steel industry in the public policy arena and advances the case for steel in the marketplace as the material of choice. AISI also plays a lead role in the development and application of new steels and steel-making technology. AISI's Market Development mission is to grow the competitive use of steel through a market-driven strategy that promotes cost-effective, steel-based solutions. The program focuses on the automotive, construction and container markets. AISI's member companies represent approximately 75% of both U.S. and North American steel capacity.

History of Steel Pipe

Pipes for water supply began to be used around 2500 B.C. The Chinese transported water through bamboo. In Southern Europe and the Near East, tile pipes were crafted to supply water for the baths of kings and emperors. The age of iron began about 1000 B.C. Classical historians don't spend their time investigating pipes; however, bits of information on pipe development have been recorded by engineers. One such document is *History of Steel Water Pipe* by Walter H. Cates, who spent his professional lifetime designing steel pipes with Consolidated Western Steel, a Division of U.S. Steel Corp. Parts of the following are abstracted from Walter Cates' document.

Search for Strength and Durability

Before the 19th Century, iron was used mostly for weapons: spears, swords, muskets and cannons. In England in 1824, James Russell invented a machine for welding iron tubes. In 1825, Cornelius Whitehouse invented a method for making pipe by drawing long, flat strips of hot iron through a bell-shaped die. These inventions opened the way for iron pipe. Iron pipe had much more strength and durability than pipes of tile or bamboo.

After the Russell and Whitehouse inventions, interest in iron pipe soared. Major development occurred in four stages:

1. In 1830, the first furnace was built in the United States for making wrought iron pipe. Soon thereafter, more furnaces came into pro-



City of San Francisco, California – Bay crossing of the Hetch Hetchy Aqueduct. 66 inches diameter, 3/8-inch and 1/2-inch steel plate.



In 1858, steel sheets, shipped to San Francisco for building needs, were rolled into pipe 11 inches to 22 inches in diameter and installed in Calaveras County, Calif. The pipe has been in use practically continuously since that time.

duction. The demand was enormous because of the need for water distribution in fast-growing cities. Those wrought iron pipes were in small diameters and few sizes. Production was limited because iron was not available in large quantities.

2. The Age of Steel was born in 1855 in England, where Sir Henry Bessemer patented a process for production of steel. Development of the open hearth furnace in 1861 made inexpensive steel available in large quantities — thousands of tons. Before then, steel had been available only by the pound. Steel made it possible to cold form sheets into pipes of any diameter. Soon after the 1849 gold rush in California, English sheet steel was formed into tubes with longitudinal riveted seams. One end of each pipe “stick” was crimped so it could be stabbed into the next stick like stove pipes. Sections were joined by simply hammering them together. From 1860 to 1900, virtually all water pipe was cold formed from steel sheets and riveted. More than 2 million feet were installed during that period.

3. The third major development was Lock-Bar steel pipe in 30-foot lengths. It was first fabricated in 1905 in New York. Two semi-circular pipe halves were joined by inserting the edges of each into two longitudinal lock-bars with an H-shaped cross section. The edges of the pipe halves were planed and up-set to a slightly greater thickness to form a shoulder for engaging the lock-bar. The lock-bar was then closed under 350 tons per foot of length. The pipe edges were clamped in the lock-bar. The seam was 100% efficient. Some single riveted seams were only 45% efficient, and double riveted seams only 70% efficient. The interior of this new pipe was smoother than riveted pipe. Carrying capability was increased by 15% to 20%, according to the manufacturer. Lock-Bar made inroads into the steel pipe market. Data from 1915 to 1930 indicate 3.3 million feet of Lock-Bar was installed vs. 1.5 million feet of riveted pipe.

4. The fourth major development was automatic electric welding. Electric welding started as a novelty in 1920, but made great progress during the 1930s, when welding machines and fluxes were developed. From 1920 to 1940, approximately 7 million feet of welded steel pipe were installed. During World War II, virtually all steel production was diverted into military equipment, arms and armament. Navy ships were welded to shorten the time of construction. Welding technology improved. After the war, the latter half of the 1940s, production began of welded steel pipe by straight seam electrical resistance and fusion welding. Spiral fusion welding was just coming on line. The 1950s began an era of longer and larger pipelines.



1907. Elsie Janis was packing 'em into the Opera House when a Philadelphia city photographer snapped a pipelaying crew on Broad Street in 1907. The City was in the process of installing nearly 27 miles of steel pipe in 48-in. and 36-in. diameters. Some of the pipe was later removed to make way for the Broad Street Subway, but most of it is still in service — after more than 100 years on the job.

Following the four major developments in steel pipe production, improvements have been made in protective coatings and joints, and quality of steel. Many dielectric coatings are now available. Good quality mortar lining is spun into pipe under the centrifugal force of high-speed rotation of the pipe. Centrifugally spun lining provides corrosion resistance and a smooth surface that assures maximum water flow. Mortar lining stiffens the flexible steel ring for handling and installing pipe. Steel provides strength, but extra steel is not needed for ring stiffness, which is of greatest value during handling and installing. Improvements in the machines for fabrication of steel pipe are remarkable.

Long Service Records

From available records, steel pipelines installed more than 100 years ago are still in service. A significant percentage of that steel pipe is still serviceable. Many of those old pipelines were replaced only because larger pipelines were needed to meet the demand for piped-in water and other piped-in services. The demand for pipes was felt worldwide, but was especially acute in industrialized nations. Appendix A, is a partial tabulation of more than 230 steel water pipelines in service before 1916 in the United States and Canada.

Future of Welded Steel Pipe

During the 21st Century, demand for pipe will increase. A worldwide demand for more cost-effective transportation will become urgent. The cost of transportation of fluids per unit weight per unit distance decreases roughly by an order of magnitude for each transportation mode: from air to surface to ship to pipe. Moreover, durable pipe with longer life will be in demand because of the too-short design life of many buried pipes now in service. For pipelines of the 21st Century, design life should be increased significantly beyond the historical 50-year life.





Properties of Steel Pipe

Steel has salient properties that can be utilized to advantage in buried pipelines. The following are desirable requirements of buried, pressurized pipe. These requirements can be achieved by welded steel pipe.

- Strength
- Ease of installation
- High-flow capacity
- Leak resistance
- Long service life
- Reliability and versatility
- Economy

1. Strength – The high strength of steel results in lightweight pipe that can resist internal pressure, and can also resist external pressure when the pipe is not pressurized. Minimum yield strength of most pipe-grade steel is 42,000 psi (290 MPa). Higher strength steels are available. Longitudinal strength (beam strength) of steel pipe is of value wherever the pipe is subjected to variable loads or is supported on non-uniform bedding, or where the pipe is buried in soil that slips or settles. Because joints can be welded, steel pressure pipe usually does not require thrust blocks at special sections (valves, tees, elbows, reducers, etc.) However, thrust restraint is required in gasketed, pressure pipelines. Longitudinal tension in buried pipe is caused by any longitudinal beam action (bending), internal pressure and decrease in temperature. The high strength of steel and the low Poisson ratio and coefficient of thermal expansion/contraction, combine to make steel pipe relatively resistant to longitudinal stresses.

2. Ease of installation – During handling and installation of buried pipe, the pipe ring must be stiff enough to hold its shape to near circular. The modulus of elasticity of steel is 30,000,000 psi (207 GPa). Materials with lower moduli must have thicker walls to provide equivalent stiffness. Under external fluid pressure, ring stiffness is needed to prevent collapse. If it is necessary to increase ring stiffness, there are a multitude of options available to the designer. Because of its longitudinal strength and relatively smooth outer surface, steel pipe lends itself to installation by microtunneling. Where native soil is recycled as flowable fill, long sections can be held down during pouring of bedding and embedment.

3. High flow capacity – Frictional resistance to flow is comparatively low in steel pipe. Typical C values to use in the Hazen-Williams formula are in excess of 140 for cement mortar, epoxy or polyurethane lined pipe. For a more detailed discussion on this subject, see American Water Works Association (AWWA) M11 (latest revision), Chapter 3, “Hydraulics of Pipelines”. Typical design



San Diego, Calif. 96-inch I.D. Pipe

velocities of flow are less than 15 feet per second (4.6 mps). If outside diameter is a limiting factor, the thin walls of steel pipe allow for larger inside diameter and greater flow capacity.

- 4. Leak resistance** – Welded joints are leak-proof. Gasketed joints are designed to be leak-proof and bottle-tight within recommended limits of pressure and offset angle of the adjoining pipe sections. The dimensions of steel bells and spigots are held within close tolerances.
- 5. Long service life** – The service life of steel pipe depends upon rates of external corrosion and internal abrasion. The service life can be increased by the use of proper coatings and cathodic protection. Technology for control of corrosion is available and well documented. Abrasion can be caused by grit in the fluid flow. Protective linings reduce abrasion. Historical service life is shown in Appendix A. If increased flow is required at some future time beyond the designed service life of the pipe, the wide margin of safety in the design of steel pipe often makes it possible to increase pressure and still keep stresses within reasonable limits. With attention to coatings and cathodic protection, the service life of steel pipe can be extended indefinitely.
- 6. Reliability and versatility** – Reliability includes the possibility of unanticipated loads and displacements such as: emergency pressure surge, water hammer, vibrations (traffic, fluid flow and earth tremors), flood, and soil movement (wash-out, differential settlement, sidehill soil slip, earthquakes, etc.). Worst case would be a coincidental accumulation of more than one of these conditions. Risk analysis would be required. Because of its toughness, steel can tolerate considerably more deformation than less ductile materials. Toughness is measured by the area under the stress-strain diagram. See Figure 1. Steel is tough because of the wide ductile range and the high ultimate stress which is over 65,000 psi for typical pipe-grade steel. Brittle material that fails at yield stress has toughness only within the elastic range. This is the resilient range wherein the material rebounds when unloaded. From Figure 1, strain of steel at elastic limit, often referred to as the proportional limit, is 0.14%.

Strain at ductile limit (fracture) is roughly 25%. This ductility provides a significant margin of safety for designers. It also dispels some rationales for design by elastic theory with failure at yield stress. Ductile properties of steel should be evaluated and considered in the design of buried steel pipe. Steels with excellent notch toughness properties are commonly available.

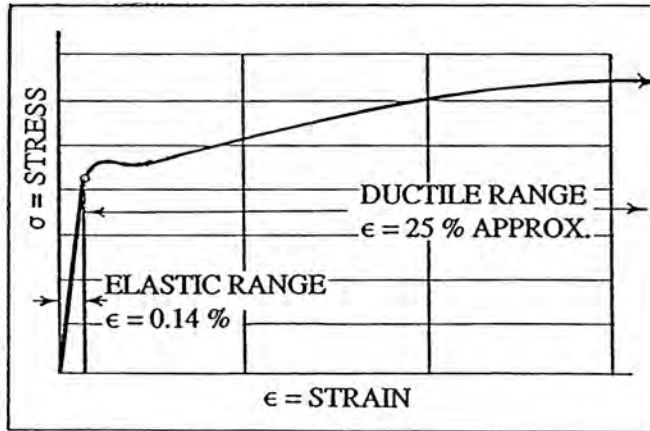

Figure 1. Stress-strain design for typical pipe-grade steel, showing the ductile range, $\epsilon = 25\%$, and the elastic range, $\epsilon = 0.14\%$.

Versatility includes the potential for modification and repair. When modification is required — such as tapping into the pipe or inserting a special section — steel pipe can be cut and welded. Repair by welding is one advantage of steel. After repair, if replacement of bedding and embedment is not the same as the initial installation, beam strength of steel pipe bridges across the excavated zone.

7. Economy – The final cost of buried pipe includes: pipe, embedment, transportation, installation, operation, maintenance, repair, modification and risk. Transporting steel pipe is cost effective, especially in large diameters, because of thin wall and light weight. (Requirements for blocks and stulls are minimal.) Installing steel pipe is expedited by light weight. Long pipe sections reduce the number of welds (or the number of bell and spigot joints that must be gasketed and stabbed). In the event of damage, steel pipe can often be repaired on site. In the event of a massive soil wash-out, welded steel pipe sections tend to hold together and minimize the disaster caused by a break in a pipeline.

Conclusions:

- Steel pipe has high strength and stiffness (modulus of elasticity).
- Steel pipe is reliable because of toughness (ductility).
- Transportation and installation of steel pipe are expedited because of light weight and toughness — tolerance for forces, deformations and impacts that fracture brittle materials.
- Steel pipe is versatile because of its ductility, and because of common procedures for cutting and welding. Special sections can be fabricated to meet virtually any requirement. Steel pipe can be provided in virtually any size and strength.
- Steel pipe is cost effective over the design life of the pipe.
- Buried pipes are the “guts” of our civil engineered infrastructure — the delivery system for many of our increasing demands for supply service. Steel pipes will figure significantly in the world’s growing infrastructures.
- All buried pipe must be designed — both the pipe and the soil embedment.

The following are considerations that should not be overlooked by designers of buried steel pipe:

- a) Quality assurance of welds.** Longitudinal stress in the pipe could possibly be limited by strength of welds. Protective coatings must be replaced over field welds.
- b) Soil conditions.** The buried steel pipe performs structurally as part of a pipe-soil interaction system. The importance of the soil must not be overlooked. Soil quality, placement and compaction are part of the design of all buried flexible pipe. Possibility of soil movement should be considered.

Buried pipes are the “guts” of our civil engineered infrastructure — the delivery system for many of our increasing demands for supply service.



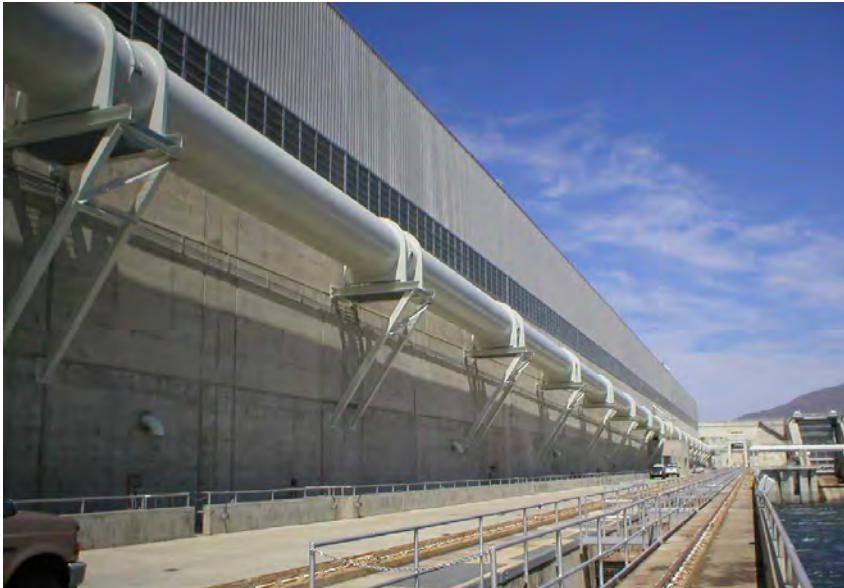

Steel pipe is versatile and can be provided in virtually any size and strength.

- c) Corrosion.** Under soil conditions that are aggressive, or under fluid flow conditions that are corrosive or abrasive, steel pipe can be protected. A more detailed discussion on this topic can be found in AWWA M11 (latest revision), Chapter 10, “Principles of Corrosion and Corrosion Control” and Chapter 11, “Protective Coatings and Linings”.
- d) Mortar lining and coating.** If the pipe is mortar-lined or mortar-lined-and-coated, mortar crack width should be limited – usually to not more than $\frac{1}{16}$ of an inch. Larger cracks are usually patched. Width of crack is a function of change in radius of curvature, which is not necessarily a function of ring deflection.
- e) Ring deflection.** For structural performance of buried steel pipe, it is conservative to limit vertical ring deflection to 5% during installation. This prevents disturbance of the soil embedment when the pipe is pressurized. Any limit less than 5% is determined by other factors than structural performance limits.

Materials

The table lists ASTM Plate and Sheet Steels for Pipe. The proper use of the grades can be made by considering all conditions for each use and comparing strength to cost ratios.

High strength steels are advantageous only when a high pressure governs the pipe wall thickness. On long lines, it is economical to use several type/grades of steel as the pressure increases along the line. For a steel pipeline, AWWA recommends a design stress at working pressure of 50% of the minimum specified yield strength of the steel.

ASTM PLATE AND SHEET STEELS FOR PIPE

ASTM Designation	Grade	Minimum Yield Strength ksi (MPa)	Minimum Tensile Strength ksi (MPa)
PLATE			
ASTM A36/36M		36 (250)	58 (400)
ASTM A283/283M	C	30 (205)	55 (380)
	D	33 (230)	60 (415)
ASTM A572/572M	42	42 (290)	60 (415)
	50	50 (345)	65 (450)
SHEET			
ASTM A139/139M	B	35 (240)	60 (415)
	C	42 (290)	60 (415)
	D	46 (315)	60 (415)
	E	52 (360)	66 (455)
ASTM A1011/1011M SS	30	30 (205)	49 (340)
	33	33 (230)	52 (360)
	36	36 (250)	53 (365)
	40	40 (275)	55 (380)
	45	45 (310)	60 (415)
	50	50 (340)	65 (450)
	55	55 (380)	70 (480)
HSLAS	45	45 (310)	60 (415)
	50	50 (340)	65 (450)
	55	55 (380)	70 (480)
HSLAS-F	50	50 (340)	60 (415)
ASTM A1018/1018M SS	30	30 (205)	49 (340)
	33	33 (230)	52 (360)
	36	36 (250)	53 (365)
	40	40 (275)	55 (380)
HSLAS	45	45 (310)	60 (415)
	50	50 (340)	65 (450)
	55	55 (380)	70 (480)
HSLAS-F	50	50 (340)	60 (415)

Note: When notch toughness properties are necessary on any steel, the purchaser shall specify the test method, e.g., Charpy Impact test, test temperature and test values.

Structural Analysis of Buried Steel Pipe

Structural analysis of buried, flexible steel pipe is the analysis of interaction of the pipe and the soil in which it is embedded. The interaction is complex. Deviations are large — in loads, in geometry and in the properties of materials. Therefore, basic principles of mechanics provide the most realistic analyses. Although approximate, these analyses are kept conservative by assuming worst-case conditions. Safety factors should be considered in any case.

Design and Analysis

Design of buried steel pipe is based on: principles of engineering mechanics, properties of materials (both pipe and soil) and performance limits. At performance limits (beyond elastic limit), steel pipe is ductile, granular soil is particulate and clay soil is plastic. Structural performance of buried flexible pipe is pipe-soil interaction. See Figure 2 for nomenclature. The pipe is a leak-proof liner and the form for a soil conduit. The soil holds the pipe in shape, and supports much of the vertical load by arching over the pipe — like a masonry arch. Vertical load compresses both sidefill soil and pipe — roughly the same amount. Vertical ring compression of the flexible pipe expands the ring horizontally, and develops horizontal support from the sidefill soil. This support is greater than would be predicted by elastic theory which is uniaxial (not biaxial) compression. Sidefill soil is compressed both vertically and horizontally (radially). This biaxial compression increases soil strength and decreases strain. Vertical compression (strain) of sidefill soil is less than the strain predicted by elastic analyses. Elastic theories over-predict ring deflection. The Iowa formula, which assumes elastic soils, was derived by Spangler* to predict ring deflection. It emphasizes the importance of horizontal soil support. It was not intended for design of the pipe.

*Spangler, M.G. (1941), Structural design of flexible pipe culverts, Bulletin 153, Iowa Engineering Experiment Station, Ames, Iowa

Performance Limit

To design buried pipe, performance limits (failures) must be identified. Structural performance limits are excessive deformations of the pipe; wall buckling, collapse and leaks. Most performance limits are beyond elastic limit and yield stress. Maximum allowable ring deflection is usually not determined by structural "failure," but by other conditions such as clearance for pipe-cleaning equipment, special sections, pipe appurtenances (attachments), and enough uplift of backfill to crack a paved surface when the pipe is pressurized. Spangler's conservative recommendation of 5% maximum allowable ring deflection is often specified for buried flexible pipe during installation. After installation, when pressurized, the pipe re-rounds. In service, after the pipe is pressurized, soil particles migrate in against the pipe and hold it in its re-rounded shape.

Steel pipe is often mortar-lined or mortar-lined-and-coated to increase ring stiffness and to prevent corrosion of the steel. In the following treatise, plain pipe is the steel cylinder with flexible, protective, dielectric coatings such as epoxy paints, polyurethanes and layers of tape that do not affect ring stiffness.

If steel is mortar-lined or mortar-lined-and-coated, a potential performance limit is excessive width of cracks in the mortar. The mortar increases ring stiffness for handling and installing the pipe. Small cracks are inevitable due to mortar shrinkage, temperature changes, handling and ring deflection. In a moist environment, small cracks in mortar lining close by autogenous healing (a build-up of calcium carbonate

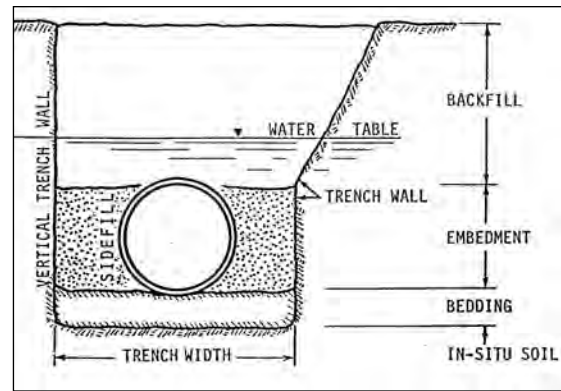

Trench cross section

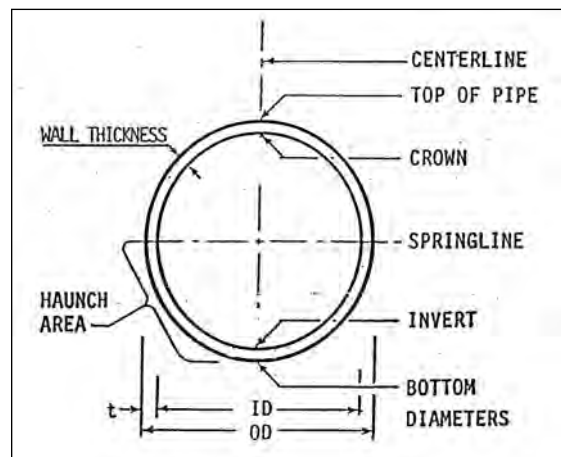

Pipe cross section

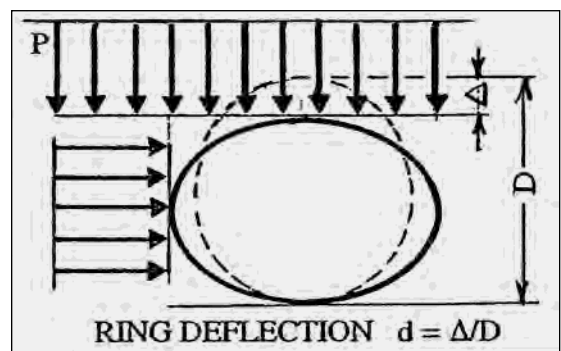

Ring deflection

Figure 2. Terminology for cross sections of buried pipe.

in the cracks). Bond is neglected in the analysis of ring stiffness. Nevertheless, bond exists, and adds to the margin of safety. A conservative limit of allowable crack width is $1/16$ inch (1.6mm).

General Analyses, page 145, are guides for preliminary design based on fundamental concepts of pipe-soil interaction. Specific Analyses, page 23, are useful in final design, special conditions and in writing specifications.

Table 1. Notation and Nomenclature

Abbreviations

kip	= 1,000 pounds
psi	= pounds per square inch [1 psi = 6.9 kPa]
ksi	= kilo pounds per square inch [1 ksi = 6.90 MPa]
ksf	= kilo pounds per square foot [1 ksf = 47.9 kPa]
pcf	= pounds per cubic foot [1 pcf = 157 N/m ³ (m = meter)]
kPa	= kilo-Pascals of pressure [Pa = N/meter ²]
N	= Newton of force [1 lb = 4.4482 N]
in	= inch [1 inch = 25.4 millimeters (mm)]

Geometry

D	= mean diameter (ID = inside diameter and OD = outside diameter)
t	= wall thickness for plain pipe (steel cylinder)
r	= mean radius of the pipe = D/2
r_i	= radius of curvature (Subscripts, j, x, y, A , indicate locations)
I	= $t^3/12$ = moment of inertia of the pipe wall cross section per unit of pipe
L	= length of pipe section or length of chord of the pipe cross section (ring)
H	= height of soil cover over the pipe
h	= height of ground water (or flood level)

Loads, Pressures, Stresses and Strains

F	= diametral line load on the pipe
P	= vertical external pressure on top of the pipe
p or P	= internal pressure or vacuum (or the equivalent external hydrostatic pressure)
γ	= unit weights of materials (Subscripts, s, c, w , refer to soil, concrete and water)
W	= wheel load on ground surface

σ	= normal stress (subscripts, x and y , refer to directions x and y . Subscript, r , refers to ratio, σ_x/σ_y . Subscripts, 1 and 3 , refer to maximum and minimum principal stresses.
σ_f	= normal stress in steel at elastic limit (near yield)
τ_f	= shearing stress in steel at elastic limit
ϵ	= vertical strain (compression) of soil

Properties of Materials

S	= allowable stress in steel pipes
E	= modulus of elasticity for steel = 30,000,000 psi (207 GPa)
E_m	= modulus of elasticity for mortar = 4,000,000 psi (28 GPa)
ν	= Poisson ratio = 0.3 for steel
α	= coefficient of thermal expansion 6.5(10 ⁶)/°F [11.7(10 ⁶)/°C] for steel
E'	= soil stiffness = modulus of the soil (slope of a secant on the stress-strain diagram)
ϕ	= soil friction angle
c	= cohesion of the soil
θ_f	= slope of shear planes at soil slip = $45^\circ \pm \phi/2$

Pertinent Parameters (Dimensionless)

D/t	= ring flexibility
$E'D^3/EI$	= stiffness ratio = ratio of vertical soil stiffness, E' , to ring stiffness, EI/D^3 or its equivalent, $E/12(D/t)^3$, for plain pipe
d/ϵ	= ring deflection term, where ϵ = vertical strain of sidefill soil
d	= ring deflection ratio = Δ/D , where Δ = decrease in vertical pipe diameter D
K	= $(1 + \sin\phi)/(1 - \sin\phi)$ = ratio of maximum to minimum principal stresses, σ_1/σ_3 , in granular soil at soil slip, where ϕ = soil friction angle



General Analyses

General analyses are used for feasibility studies and engineers' estimates. They are presented here in a typical order of procedure. See Figure 2 and Table 1 for nomenclature and notation that are common in the technology.

1. Internal Pressure, P

Internal pressure causes circumferential tension stress in the pipe wall,

$\sigma = PD/2t$, often referred to as the hoop stress formula. Based on allowable stress, S, the maximum allowable ring flexibility, is:

$$D/t = 2S/P \quad (1)$$

Where

D/t = ring flexibility of plain* pipe

D = diameter of the pipe (ID \approx OD)

t = wall thickness

P = pressure in the pipe (or on the pipe)

S = allowable stress in the pipe

(*Plain pipe is the steel cylinder without mortar lining or coating. Plain pipe may be protected with paint or tape that does not affect ring stiffness.)

Allowable stress, S, is 50% of yield stress when design is based on working pressure. When design is based on transient pressure, the allowable stress is increased to 75% of yield stress.

Example

What is the maximum allowable ring flexibility, D/t, for grade 42 steel, if the working pressure is 150 psi (1.0 MPa)? Yield stress for 42 grade steel is no less than 42 ksi. At 50% of yield stress, the allowable stress is, S = 21 ksi. Substituting working pressure, P = 150 psi, into Equation 1, the maximum allowable D/t is 280.

Figure 3 shows how allowable pressure, P, varies as a function of D/t.

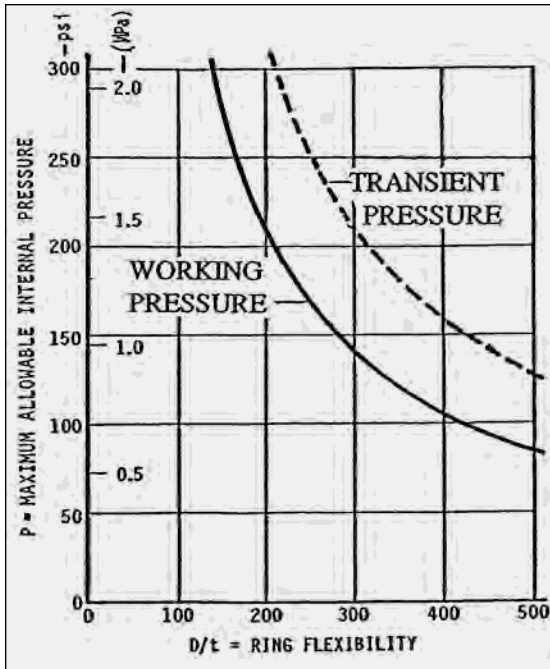

Figure 3. Maximum allowable pressure in steel pipe if yield stress in steel is 42 ksi (290 kPa). The lower plot is based on working pressure for which allowable hoop stress is 21 ksi (145 kPa) = 50% of yield stress. The upper plot (dotted) is based on transient pressure of 31.5 ksi (217 kPa) which is 75% of yield stress. Appendix B details working pressure data for pipe diameters ranging from 4.5 inches (114 mm) to 156 inches (3,960 mm).

2. Handling and Installing

The loads on pipe during handling and installing, are usually diametral line loads that could dent the pipe or crack mortar lining or coating. Handling may require the use of slings and straps. Pipe must not be stacked higher than the ring deflection limit of the bottom pipe. Embedment is an integral part of conduit. Therefore, specifications are as important for the soil as for the steel. For large diameter pipe, soil should be placed carefully, including under the haunches — not just “dozed-in” over the pipe. The embedment is part of the conduit, and should be installed as a structural component. Below the water table, embedment should be dense enough to prevent soil liquefaction — at least 85% Standard Density (ASTM D 698 or AASHTO T-99). Embedment controls ring deflection. Unfortunately, material properties are less precise for soil than for steel. Based on experience in handling and installing pipe, the following specifications for minimum wall thickness are in common use:



Embedment is an integral part of conduit. Therefore, specifications are as important for the soil as for the steel. For large diameter pipe, soil should be placed carefully, including under the haunches — not just “dozed-in” over the pipe. The embedment is part of the conduit, and should be installed as a structural component. Below the water table, embedment should be dense enough to prevent soil liquefaction — at least 85% Standard Density (ASTM D 698 or AASHTO T-99). Embedment controls ring deflection. Unfortunately, material properties are less precise for soil than for steel. Based on experience in handling and installing pipe, the following specifications for minimum wall thickness are in common use:

$$\begin{aligned}
 t &= (D + 20)/400 \text{ inches} \\
 &= (D + 500)/10,000 \text{ mm} \\
 &\text{U.S. Bureau of Reclamation} \qquad \qquad \qquad (2)
 \end{aligned}$$

$$\begin{aligned}
 t &= D/288 \\
 &\text{Pacific Gas and Electric} \qquad \qquad \qquad (3)
 \end{aligned}$$

Equation 2 is more liberal in diameters greater than 54 inches (1,350 mm), and Equation 3 is more liberal in diameters less than 54 inches. From the P.G. & E. formula, ring flexibility is $D/t = 288$, which is a typical upper limit of ring flexibility for buried pipe. However, where handling and installation are controlled, D/t can exceed 288.

3. Ring Stability

Stability is resistance to collapse by external pressure (and internal vacuum). Resistance to collapse depends upon ring flexibility, D/t and soil embedment. See example, Figure 4, for critical vacuum, p , in plain pipe if $D/t = 288$. Typical recommended upper limits of ring flexibility of pipe are:

Maximum Ring Flexibility for Plain Pipe
 $D/t = 158$ for full vacuum (atmospheric pressure and/or external hydrostatic pressure)

$D/t = 240$ for cement mortar lined pipe with flexible coating

$D/t = 288$ for pipe in select embedment, carefully placed and compacted

These are conservative recommendations assuming that ring deflection is less than 5%. If the pipe is mortared-lined or mortar-lined-and-coated, ring stability is based on ring stiffness, EI/D^3 , rather than D/t . After the pipe is embedded and pressurized, ring flexibility and ring stiffness are no longer pertinent properties for ring stability. The pipe-soil interaction is stable.

Unburied pipe

An unburied, circular, plain pipe with $D/t = 158$ or less, can withstand internal vacuum of atmospheric pressure, $p = 14.7$ psi (100 kPa). The critical vacuum (at collapse) includes external pressure such as the pressure on pipe immersed in water or grout.

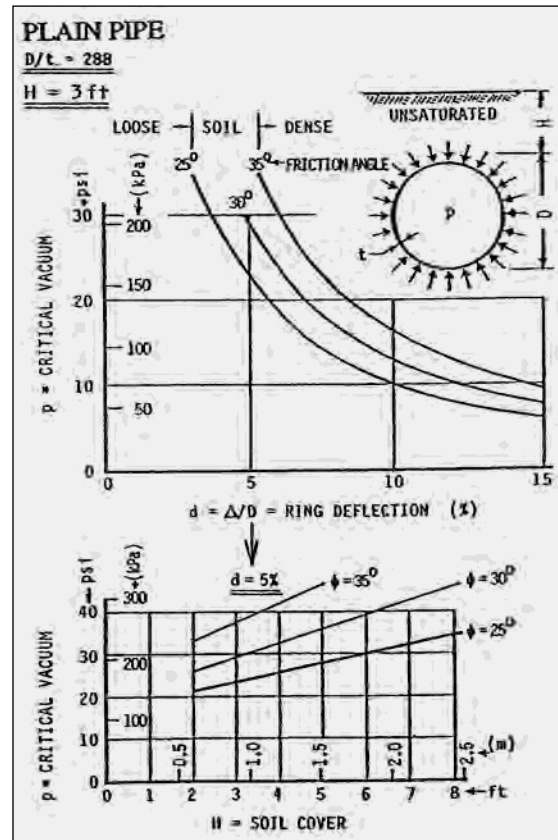

Figure 4. Example of internal critical vacuum (water level below the pipe) in a plain pipe in unsaturated soil for which:

$D = 72$ inches (1,800 mm)

$t = 1/4$ inch (6.35 mm)

$D/t = 288$

$p =$ internal vacuum

$H = 3$ feet (0.9 m) [top graphs]

$d = 5\%$ [bottom graphs]

Soil unit weight = 100 pcf (15.7 kN/m³)

Buried pipe

A buried circular pipe is supported by the embedment. Soil support increases critical vacuum depending on soil quality, density of the soil and ring deflection. However, a water table above the pipe decreases soil support. Therefore, two cases of soil support must be analyzed — unsaturated and saturated.

Example

Unsaturated Soil (water table below the pipe)

A 72-inch (1,800 mm) plain pipe is buried in unsaturated granular soil weighing 100 pcf (15.7 kN/m³). Wall thickness is $t = 0.25$ inch (6.35 mm). $D/t = 288$. Height of soil cover is 3 feet (0.9 m). What is the critical vacuum? Figure 4 shows critical vacuum. For derivation, See Specific Analyses, page 23. As long as ring deflection is less than 5%, the pipe can withstand a vacuum greater than atmospheric — even in less-than-select (loose) embedment. Mortar lining increases the safety factor.

If ring deflection is less than 5%, and if embedment is not compacted, but not saturated, and $D/t = 288$ or less, the ring is stable under full atmospheric vacuum.

From the diagram at the bottom of Figure 4, for which ring deflection is $d = 5\%$, critical vacuum, P , increases as height of soil cover, H , increases. Confinement of the ring is improved with increased depth to springline.

Example

Saturated Soil (water level above the pipe)

A 72-inch (1,800 mm) plain pipe is buried in saturated granular soil weighing 125 pcf (19.6 kN/m³). Wall thickness is $t = 0.375$ inch (9.5 mm). $D/t = 192$. Height of soil cover is $H = 3$ feet (0.9 m). See Figure 5. Because water level is above the pipe, this wall is designed to be thicker than the unsaturated example in Figure 4. What is the critical vacuum (including external hydrostatic pressure)? Figure 5 shows plots of critical vacuum as functions of ring deflection and soil friction angle. From Figure 5, it is noteworthy that:

If ring deflection is less than 5% and if $D/t = 192$ or less, the ring is stable under full atmospheric pressure.

If the plain pipe of Figure 5 were mortar-lined, what would be critical vacuum? Clearly, the ring stiffness is increased, so critical vacuum is increased.

Suppose this pipe is buried in well-compacted granular embedment for which $\phi = 35^\circ$. If ring deflection is $d = 5\%$, and if “critical vacuum” is caused by external hydrostatic pressure, what is the height of water surface, h , at collapse when the pipe is not pressurized? This could be a river crossing or a flood. From Figure 5, critical vacuum is, $p = 24$ psi (166 kPa). Converting units, water level above ground surface is,

$$h = (p)/0.433 \text{ psi/ft} - (H + D/2) = 49 \text{ feet (15 m)}.$$

The effect of soil cover, H, is shown at the bottom of Figure 5. It must be remembered that stability analyses apply only to unpressurized pipe. Once the pipe is pressurized, internal pressure usually prevails over external soil pressure, the ring re-rounds and resists external pressure — both soil and hydrostatic pressure. A typical internal pressure of 80 psi (550 kPa) prevails over a typical soil cover of 6 feet, which exerts a pressure of about 5 psi (36 kPa).

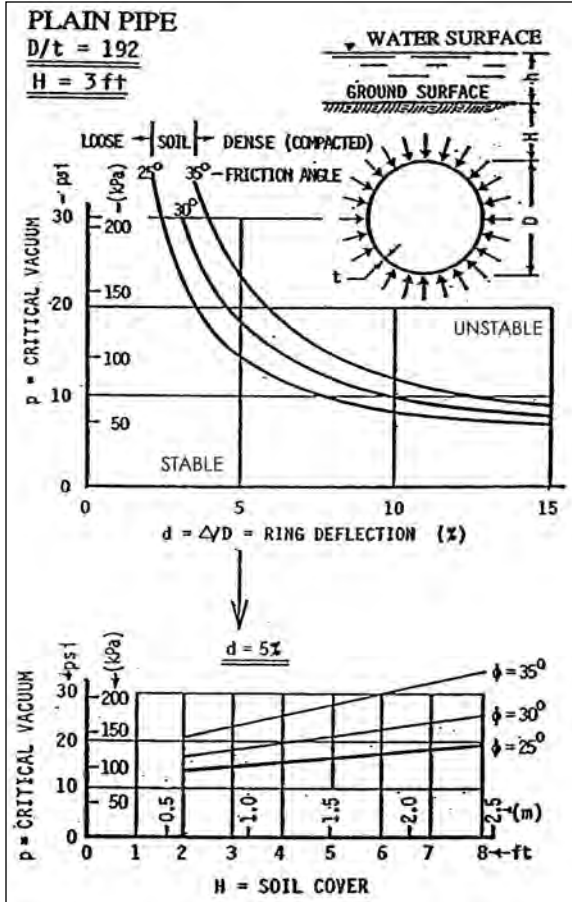

Figure 5. Example of internal vacuum (including external hydrostatic pressure) at collapse of a buried, plain pipe in saturated soil. Water surface is above the pipe.

$D = 72 \text{ inches (1,800 mm)}$

$t = 0.375 \text{ inch (9.5 mm)}$

$D/t = 192$

$H = 3 \text{ feet (0.9 m)}$ [top graphs]

$d = 5\%$ [bottom graphs]

$h = \text{height of water surface above ground}$

Saturated soil unit weight

$= 125 \text{ pcf (19.6 kN/m}^3\text{)}$

4. Maximum Height of Cover for Pipe Held Round

Maximum height of soil cover is found by equating ring compression stress to allowable strength of steel. The result is Figure 6 which shows maximum allowable soil cover, H , as a function of D/t . Because of the strength of steel, maximum height of cover is seldom an issue.

5. Minimum Height of Cover

Minimum height of soil cover over a buried pipe may be of concern because of frost, flotation of the pipe in saturated soil, and ring deformation due to surface wheel loads. Frost depth is usually not critical unless slow flow in the pipe allows water in the pipe to freeze, or unless the pipe is on a sidehill slope within the soil creep zone wherein soil slips (creeps) incrementally down the slope due to cycles of freezing and thawing.

Flotation is caused by liquefaction of saturated embedment. Flotation is prevented by soil cover of at least half a pipe diameter of soil above the pipe. The pipe is assumed to be empty (worst case). In order to avoid liquefaction, soil density should be greater than 85% standard (ASTM D698 or AASHTO T-99). Design engineers usually specify a minimum of 90% density.

Minimum soil cover required for surface live loads is based on the wheel load, W , and ring flexibility, D/t . Performance limit is localized inversion of the top of the pipe due to "punch-through" of a truncated pyramid of soil. Figure 7 shows minimum cover of compacted granular soil for an AASHTO HS-20 dual-wheel loading.

Example

What is the minimum soil cover over a pipe for which $D/t = 288$ if a wheel load of 16 kips (70 kN) must pass over? The soil is compacted to density greater than 85% (ASTM D698 or AASHTO T-99). From the plastic analysis of Figure 7, $H = 13$ inches (325 mm).

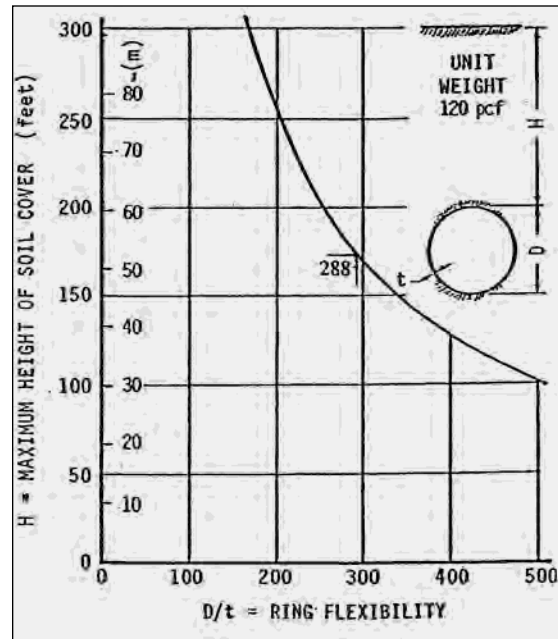

Figure 6. Maximum allowable height of soil cover over a plain pipe, based on ring compression stress of 21 ksi (145 kPa) and soil unit of weight of 120 pcf (18.8 kN/m³). Unit weight can be adjusted for unit weights other than 120 pcf (18.8 kN/m³) by inverse proportionality. For example, if unit weight is only 100 pcf (15.7 kN/m³), the maximum height of soil cover is increased by a factor of 120/100. It is assumed that ring deflection is less than $d = 5\%$. For development of Figure 6, see *Specific Analyses*, page 24.

In this example, the ground surface is unpaved. As a load approaches (shown left of pipe centerline), the bending moment in the ring is maximum on the right. The required D/t is based on that bending moment. The elastic analysis graphs show soil cover at yield stress. But elastic theory is not inversion. The plastic analysis graphs are on the verge of plastic hinging. For design, the elastic graphs are used because of a built-in safety factor. The contributions of longitudinal soil arching and pipe beam strength are disregarded. Typically engineers consider a soil cover of 3 feet (0.9 m) to be minimum. A 3 feet (0.9 m) minimum may also be desired for other reasons such as dynamic and repetitive loads, bedding settlement, etc.

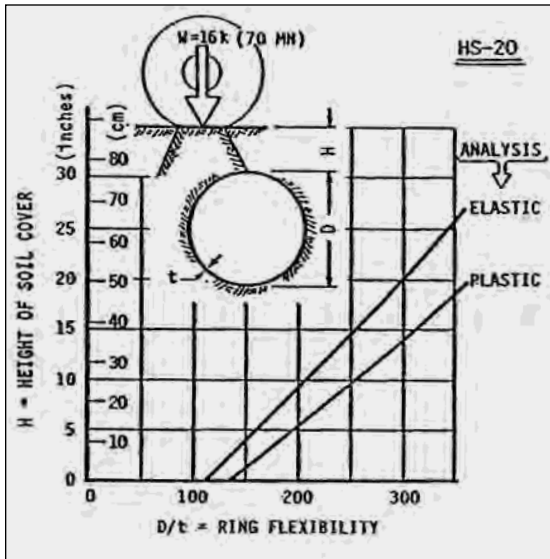

Figure 7. Minimum soil cover (with built-in safety factor) for pipes buried in compacted granular soil denser than 85% (ASTM D698 or AASHTO T-99) with wheel loads:
 $W = 16$ kips (70 MN) – HS-20 on unpaved surface

6. Longitudinal Stress Analysis

Longitudinal stresses in a buried pipe can be caused by: changes in temperature and pressure in the pipe, longitudinal beam action of the pipe, and pressure thrust. A pipe descending a steep slope feels thrust due to gravity. Thrust restraints must be provided. For welded joints, the pipe itself provides thrust restraint. For pipes with gasketed joints or slip couplings, external thrust restraints must be provided. Longitudinal restraint is also developed by soil pressure against the pipe and the coefficient of friction of soil-on-pipe.

One worst-case of longitudinal tensile stress is a straight, fixed-end pipe (external thrust restraints at the ends) subjected to decrease in temperature and internal pressure. In general, steel pipe is well suited to resisting longitudinal stress. However, slip couplings or temperature joints at proper spacing along the pipeline can relieve the pipe of longitudinal stresses which must then be resisted by external thrust restraints.

7. Ring Deflection

Steel pipes are generally flexible enough that the ring conforms with the soil. Therefore, ring deflection of unpressurized pipe is approximately equal to (no greater than) vertical compression of the sidefill soil embedment.



Vertical compression of the soil is sometimes predicted by a laboratory confined compression test. The laboratory test is conservative. The laboratory sample is confined horizontally in a cylinder and is compressed vertically. This is uniaxial compression. Sidefill soil is compressed vertically, compressed horizontally (radially) and confined longitudinally. This is biaxial compression for which the compression (vertical strain) is less than it is for uniaxial, confined compression tests.

8. Allowable Ring Deflection

Because ring deflection can affect all of the analyses described above, it is prudent to control ring deflection by specification — either directly by a performance specification, or indirectly by procedural specifications that assure compaction of sidefill soil. Ring performance is not affected significantly by ring deflection less than 5%. In the 1940s, Professor Spangler recommended maximum allowable ring deflection of 5% based on a safety factor of four and potential ring inversion at 20% ring deflection. Spangler's 5% is still considered to be maximum allowable for buried plain pipe, but for reasons other than ring inversion. Special sections and mortar coating may justify ring deflection less than 5%. If ring deflection is less than 5%, the embedment is not disturbed appreciably when the pipe is re-rounded during pressurization.

A limited allowable ring deflection of mortar-lined pipe is not warranted solely to prevent disbonding and cracking of mortar lining. The purposes of lining are: improved flow, protection against corrosion of the steel and increased ring stiffness for transporting and handling the pipe. Small cracks and minor disbonding typically occur in the lining. After installation, cracks may be visible at the crown and invert. As a conservative rule of thumb, cracks less than $\frac{1}{16}$ inch (1.6 mm) wide (thickness of a dime) are not critical. Moreover, in most moist environments, cracks tend to close by autogenous healing. Wider cracks can often be sealed or patched. Attempts to relate crack width to ring deflection are not responsive to the purposes of the lining. Crack widths are caused by material shrinkage, and by increased radius of curvature (flat spot) in the ring. Allowable ring deflection should not be limited just to avoid small cracks in the lining. Mortar coatings are thicker than linings; so crack widths are proportionately greater and usually open at the springline. Cracks in the mortar coating usually do not penetrate to the steel. It is possible to estimate the maximum width of a single mortar crack at springline by measuring the radius of curvature inside the pipe at springline. Mortar cracks due to ring deflection are not an issue once the pipe is pressurized. Accumulated cracks do not open in mortar linings when the pipe is pressurized. The mortar itself expands under the internal pressure.

9. Backfill and Embedment Specifications

Soil protects the pipe, supports the pipe, and maintains pipe alignment. The soil should not move excessively. It should be in full contact with the pipe and dense enough to assure ring stability. Sidefill should be dense enough that vertical compression (strain) does not exceed allowable ring deflection. Where necessary, embedment can be placed and compacted in lifts to achieve adequate density. Under some circumstances, flowable fill may be used for embedment. In the event that the soil does move, the ductility of steel makes the pipe better able to deform than less flexible pipes. In many locations, some soil movement is inevitable. Soil movement includes: subsidence caused by nearby surface loads (such as new construction) or



long term consolidation of native soil under fills, uplift of soil in areas of expansive clay, sideslip due to construction alongside the pipeline, etc.

Stulls are often placed in large pipe with low ring stiffness in order to prevent damage during handling, and to hold the pipe in circular shape during handling and installing.

Specific Analyses

The interaction of buried flexible pipe and its soil embedment is mutually complementary. The pipe forms a conduit. The soil holds the pipe in shape, and supports and stiffens it. The soil arch protects the pipe and supports much of the external load. Analysis is based on interaction of pipe and soil. Pipe ring analysis is useful but conservative because:

1. Ring stiffness, EI/D^3 , is neglected in most calculations involving flexible pipe.
2. Longitudinal beam restraint to localized ring deformation is neglected.
3. External pressure on the pipe ring is analyzed separately from internal pressure.
4. Shearing between soil and pipe is neglected.
5. Biaxially compressed sidefill offers greater support than the uniaxially compressed soil assumed in the analyses.

Pertinent Variables

There are many pertinent variables in the complex interaction of pipe and soil. See Figure 2 and Table 1 for notation and nomenclature. One widely recognized variable is ring flexibility, D/t , which is an inverse form of ring stiffness, EI/D^3 , and may be used for analyses involving ring stiffness of plain steel pipe (no mortar linings or coatings). Another common variable is ring deflection, $d = \Delta/D$, which is roughly

equal to vertical compression of the sidefill embedment. Ring deflection, d , is usually limited by specification to lessen its effect on structural performance. Ring stiffness is EI/D^3 , where I is the centroidal moment of inertia of the wall cross section per unit length of pipe. The procedure for evaluating I for pipes with mortar linings and coatings is discussed under, The Effect of Mortar Linings and/or Coatings on Ring Stiffness, page 58. The most pertinent soil variables are strength at soil slip (soil friction angle, ϕ) and vertical strain of sidefill embedment, ϵ . An approximation of strain is, $\epsilon = \sigma/E'$ where σ is vertical soil stress, and E' is vertical soil modulus. Soil modulus is not a modulus of elasticity. It is not a constant. It is often found, approximately, as the slope of a secant to the stress-strain diagram from laboratory compression tests.

Example

Table 2 shows values of ring stiffness, EI/D^3 , for an American Water Works Association (AWWA) mortar-lined-and-coated steel pipe. It is assumed, conservatively, that there is no bond between mortar and steel. In fact, there is bond. Ring stiffness is $\Sigma EI/D^3$ of the separate ring stiffnesses of steel, lining and coating. Modulus of elasticity of steel is 30,000,000 psi (207 GPa). Modulus of elasticity of mortar is taken as 4,000,000 psi (27.6 GPa). Subscripts, s,L , and c , represent respectively, steel, lining and coating. In Table 2, it is noteworthy that the contribution of the steel cylinder to the total ring stiffness, EI/D^3 , is only 7% while the cement mortar thicknesses (both lining and coating) contribute 93% to the total ring stiffness. Little is gained by increasing steel thickness. On the other hand, by increasing the mortar thickness by $1/4$ inch (6.35 mm), ring stiffness is increased by a factor of 2.4. Increasing mortar thickness is one method of increasing ring stiffness. Including mortar-steel bond, ring stiffness is actually up to five times greater than the values shown in Table 2. The AWWA recommendations for mortar thicknesses are listed in Table 3.

Table 2. Ring Stiffness, EI/D^3 for a Mortar-Lined and Coated Pipe

based on the $\Sigma EI/D^3$, for coating, steel and lining. Bond of mortar to steel is neglected.

- D = 42 inches (1,050 mm)
- t_s = 0.175 inch (4.445 mm)
- D/t = 240
- E = 30,000,000 psi (207 GPa)
- E_m = 4,000,000 psi (28 GPa)
- N = $7.5 = E_s/E_m$

INCREASED MORTAR THICKNESS BOOSTS RING STIFFNESS			
$t_L = 0.50$ inch (13 mm)		$t_L = 0.75$ inch (19 mm)	
$t_c = 0.75$ inch (19 mm)		$t_c = 1.00$ inch (25 mm)	
Values of EI/D^3		Values of EI/D^3	
coating	1.64 psi $D = 44.100$ inches	coating	3.69 psi $D = 44.850$ inches
steel	0.17 psi $D = 43.175$ inches	steel	0.16 psi $D = 43.675$ inches
lining	0.54 psi $D = 42.500$ inches	lining	1.80 psi $D = 42.750$ inches
$\Sigma EI/D^3 =$	2.35 psi	$\Sigma EI/D^3 =$	6.01 psi

Table 3. Recommended Thickness of Mortar Linings by AWWA C-205.

D = NOMINAL PIPE DIAMETER		t _L = LINING THICKNESS	
inches	(mm)	inches	(mm)
4 – 10	(100 – 250)	¼	(6)
11 – 23	(275 – 575)	⅝ ₁₆	(8)
24 – 36	(600 – 900)	¾	(10)
>36	(900)	½	(13)



Performance Limits

Performance limits are excessive deformation of the pipe and excessive soil movement. Deformation of the pipe includes out-of-roundness, fractures, localized buckling, etc. Movement of the soil includes soil settlement, washout of soil from around the pipe, soil liquefaction, and soil slip. Excessive pipe deformations occur beyond yield stress in the ductile range of steel where elastic yield stress analysis loses relevancy. Yield stress analysis is widespread because of general

familiarity with elastic theory. Performance limit of buried steel pipe is yield stress for internal pressure and ring compression. But the pipe must also be able to resist loads caused by handling and installing. The pipe-soil conduit must resist external pressure.

The allowable limits set by designers are often called “failures” even though the pipe may still perform adequately. Typical allowable limits for design are:

1. Strength of steel – one-half of yield stress if design is based on internal working pressure; three-fourths of yield stress if design is based on internal transient pressure; and one-half of yield for external ring compression and longitudinal stresses including bending (beam action). Strength of welds at joints may limit longitudinal strength.
2. Ring stiffness – lower limit of EI/D^3 (0.1 psi based on D/t of 288), for plain pipe, or $\Sigma EI/D^3$ for mortar-lined or mortar-lined-and-coated pipe to facilitate installation and to prevent collapse. For plain pipe, the same objectives are accomplished by an upper limit of D/t called ring flexibility.
3. Ring deflection – during installation. Spangler’s 5% ring deflection is a reasonable design standard. For mortar-coated pipe in saturated soil (electrolyte) with electrical ground current and no cathodic protection, 2% ring deflection is sometimes specified as an upper limit. For mortar-lined, dielectric coated pipe, 3% is often specified as an upper limit. Pressurized pipe re-rounds and cracks in mortar tend to close.

Equations of elasticity are sometimes used to specify maximum allowable ring deflection based on ring stiffness. This rationale does not apply to buried steel pipe for two reasons.

1. Ring stiffness of steel pipe is so small compared to soil stiffness, that its effect on ring deflection is negligible. Ring deflection is a function of soil compression.
2. Probable deviation of ring deflection is determined by probable deviations of the soil. Soil deviations are large. The deviation of the dependent variable is equal to the square root of the sum of the squares of the deviations of the independent variables.

Example

If soil variables and probable deviations, in \pm percent, are as listed below, what is the probable deviations of a specified ring deflection of 3%?

d = ring deflection

$\gamma = 100 \text{ pcf} \pm 10\%$ = unit weight of soil (1.6 kN/m^3)

$H = 10 \text{ feet} \pm 20\%$ = height of soil cover (3 m), and may include live load effect

$E' = 1,000 \text{ psi} \pm 25\%$ = modulus of the soil (6.9 MPa)

From the sum of the squares, the deviation is $\pm 33.5\%$. Therefore, $d = 3\% \pm 1\%$. Ring deflection is somewhere within a range of $d = 2\%$ to $d = 4\%$. This is not an accurate basis for specifying allowable ring deflection. Criteria other than ring stiffness should be used to specify allowable ring deflection.

Design for Internal Pressure

When designing pipe for internal pressure, it is conservative to neglect external soil restraint. Circumferential (hoop) stress in the pipe wall is found by the formula $\sigma = PD/2t$, from which minimum pipe wall thickness is, $t = PD/2S$.

Diameter, D , is inside diameter, but for thin-wall steel pipes, the differences in mean diameter, nominal diameter and inside diameter are negligible. Design strength, S , is specified to be one-half of yield strength — typically $S = 21 \text{ ksi}$

(145 MPa) based on design for working pressure. Based on transient pressure, $S = 31.5 \text{ ksi}$ (217 MPa). High strength steels are available.

Longitudinal stress due to internal pressure is less than half the circumferential stress. See Longitudinal Stress Analysis, Page 21.

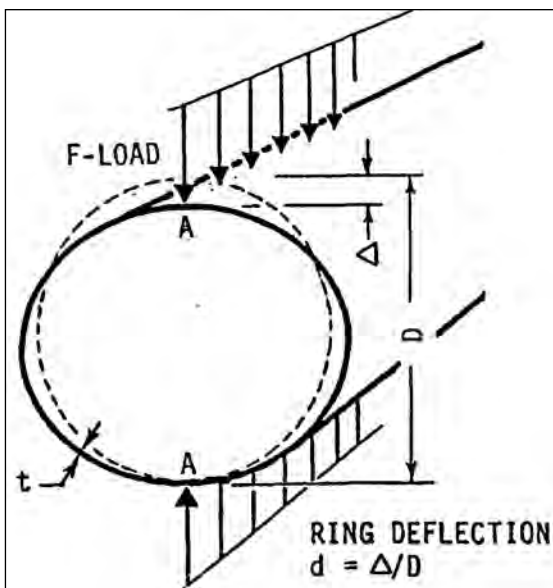

Figure 8. F-load on a pipe during handling and installing.



Handling

Handling forces on a pipe are generally diametral F-loads. See Figure 7. Point loads are analyzed conservatively as line loads. From Castigliano's equation for deflection, and the equations of equilibrium, the moment in the ring at A, is:

$$M_A = Fr/\pi \quad (4)$$

Castigliano's equation is found in texts on mechanics of solids. Maximum circumferential stress on the surface of plain pipe is $\sigma = 6M_A/t^2 = 6Fr/\pi t^2$ at point A. Strain (below yield) is $\epsilon = \sigma/E$.

$$\epsilon = 6Fr/\pi Et^2 \quad (5)$$

A conservative performance limit is yield stress. Beyond yield, surface strain in the steel pipe might initiate disbonding of mortar lining and coating. The strain at yield is, $\epsilon_y = 1.4(10^{-3})$ if yield stress is $S_y = 42,000$ psi (290 MPa) and $E = 30,000,000$ psi (207 GPa). Yield stress in plain pipe during handling is not performance limit. A safety factor is built in.

F-load at Yield Stress

See Figure 8. From Equation 4, the moment at A is $M_A = Fr/\pi$. Moment resistance at yield stress, S_y , from theory of elasticity, is $M_A = 2S_y I/t$. Equating and solving, $FD = 4\pi S_y I/t$. For plain pipe,

$$F = \pi S_y D/3(D/t)^2 \quad (6)$$

Example

What is the F-load on plain pipe at yield stress? $D = 72$ inches (1,800 mm), $t = 0.300$ inch (7.6 mm), $(D/t) = 240$, and $S_y = 42$ ksi (290 MPa). Yield stress on the surface of the steel is a very conservative performance limit because permanent deformation has not started, and, even if it had, yielding does not decrease strength or reduce service life. Substituting values into Equation 6, the F-load at yield stress is $F_e = 660$ lb/ft (9.6 kN/m). At plastic hinging, $F_p = 990$ lb/ft (14.4 kN/m). The plastic moment is 1.5 times the elastic moment at yield stress. The F-load is avoided by using chocks, cradles, stulls, etc., during handling and transporting.

Ring deflection, d, at Yield Stress Due to F-Load

One way to find out if yield stress is exceeded by an F-load is to measure the ring deflection between points A. See Figure 8. From mechanics of solids, $d = 0.0186FD^2/EI$. At points A, $FD = 4\pi S_y I/t$.

$$d = 0.234(S_y/E)(D/t) = 0.234\epsilon_y(D/t) \quad (7)$$

Example

A plain pipe is F-loaded. See Figure 8. What is the ring deflection when stresses at points A reach yield?

$D = 72$ inches (1,800 mm), $t = 0.300$ inch (7.62 mm),
($D/t = 240$, and $S_y = 42$ ksi (290 MPa) at $\epsilon_y = 1.4(10^{-3})$).

Substituting into Equation 7, $d = 7.9\%$. F-load analyses apply to handling. F-load analyses do not apply to pipe after it is buried.

Soil Mechanics

The soil in which a pipe is buried is an important component of the conduit. Soil applies pressure on the pipe, but it also supports the pipe and much of the load. The pertinent variables in soil analysis are stress, strength, unit weight and vertical soil compressibility (strain). Sidefill soil compressibility affects ring deflection.

Soil stresses: The basic soil stress is P acting vertically on top of the pipe. It includes weight of soil, external hydrostatic pressure and the effect of live surface loads. Soil support is based on soil strength which is affected by groundwater. Vertical compression of the sidefill soil causes ring deflection. Soil compression is caused by intergranular (effective) soil pressure, \bar{P} (which is total pressure, P minus hydrostatic pressure, u):

$$\bar{P} = P - u = P - h\gamma_w \quad (8)$$

Pressure on the pipe is:

$$P = P_d + P_1 \quad (9)$$

where

P = vertical pressure on the pipe

P_d = dead load pressure = pressure of the soil on the pipe (See Figure 9)

P_1 = live load pressure = the effect of surface loads on the pipe (See Figure 10)

γ = unit weight of the soil

γ_w = unit weight of water

H = height of the soil cover

h = height of the water table above the pipe

W = live load on the ground surface over the pipe (wheel load)

u = hydrostatic pressure = $h\gamma_w$

Live load pressure, P_1 , directly below surface load, W , is:

$$P_1 = 0.477W/H^2 \quad (10)$$

Graphs are available for evaluating P . Figure 11 is an example.

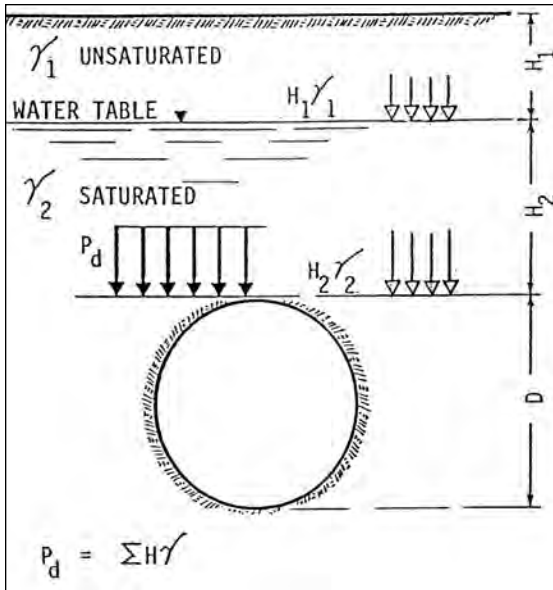

Figure 9. Dead load pressure, P_d , at the top of the pipe.

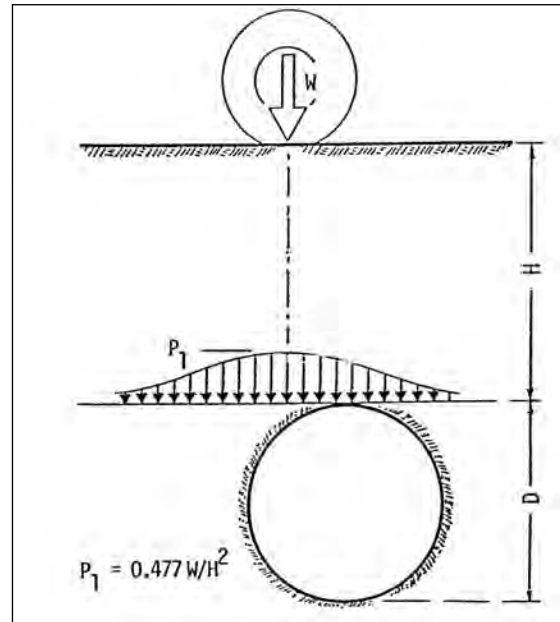

Figure 10. Live load pressure, P_1 , at the top of the pipe due to a concentrated surface load, W . (after Boussinesq See texts on geotechnical engineering.)

Example

Find the pressure on top of a pipe if an HS-20 dual wheel load passes over. Dual wheel load is $W = 16$ kips (71 kN). Height of cover is $H = 8$ ft (2.44 m). The water table is $h = 5$ ft (1.52 m) above the pipe. Unit weights are: 100 pcf (15.7 kN/m³) above the water table, and 125 pcf (19.6 kN/m³) below the water table.

Dead load pressure on the pipe is

$$P_d = (3 \text{ ft})(100 \text{ pcf}) + (5 \text{ ft})(125 \text{ pcf}) = 925 \text{ lb/ft}^2 (44.3 \text{ kPa}).$$

From Equation 10, live load pressure due to the 16 kip dual wheel load is

$$P_1 = 119 \text{ lb/ft}^2 (5.7 \text{ kPa}).$$

From Equation 9, the sum is

$$P = 1,044 \text{ lbs/ft}^2 (50 \text{ kPa}).$$

From Equation 8, effective pressure is

$$\bar{P} = P - P_u = 1,044 - (62.4)5 = 732 \text{ lbs/ft}^2 (35 \text{ kPa}).$$

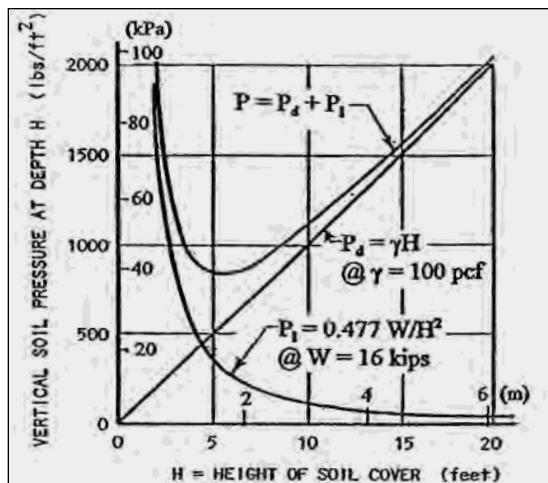

Figure 11. Vertical soil pressure under one dual wheel load of an HS-20 truck, acting on pipe buried at depth of cover H in soil for which unit weight is 100 lb/ft³ (15.7 kN/m³).

Soil Strength

Soil slip is a performance limit. Resistance to slip is soil strength that comprises soil cohesion and soil friction. Rarely is there cohesion in the embedment. Under some conditions flowable fill (soil cement slurry) with cohesion may be used to fill voids under pipe haunches. But most pipe is embedded in granular soil for which cohesion is negligible. Soil strength is the ratio of maximum to minimum principal stresses at soil slip. See Figure 12.

If vertical stress, σ_y , is minimum, the maximum horizontal stress at slip is $\sigma_x = K\sigma_y$, where $K = (1 + \sin \varphi)/(1 - \sin \varphi)$.

Friction angle, φ , is a function of soil compaction. For granular soil with some compaction, the friction angle is often assumed conservatively to be $\varphi = 30^\circ$ from which $K = 3$. The soil slips if the ratio, σ_x/σ_y , exceeds 3.

If $\varphi = 35^\circ$, $K = 3.69$.

If $\varphi = 25^\circ$, $K = 2.46$.

If $\varphi = 15^\circ$, $K = 1.70$.

The soil slips on planes at angles, $\theta_f = 45^\circ - \varphi/2$ from horizontal. See Figure 12.

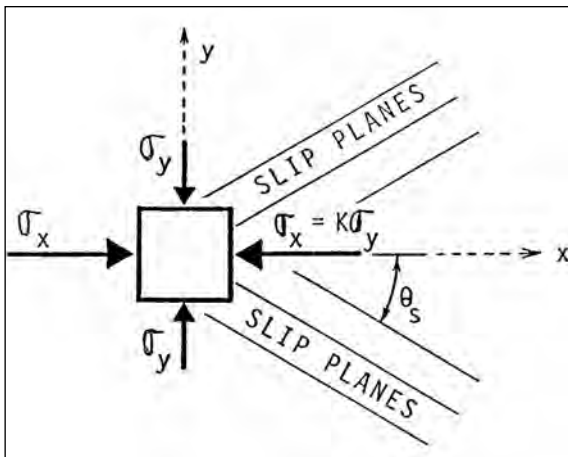

Figure 12. Infinitesimal soil cube showing the maximum stress σ_x (passive) and minimum stress σ_y (active) at soil slip. Slip planes form at angles, $\theta_s = 45^\circ - \varphi/2$.

Soil Friction Angle

Values of soil friction angle, φ , can be provided by soil testing laboratories. However, for granular sidefill soil, Figure 13 shows conservative values of φ as a function of soil density. The conservatism is justified because soil around a buried pipe is not uniform.

At soil slip, the horizontal stress (passive resistance) is $\sigma_x = K\sigma_y$ where $K = (1 + \sin \varphi)/(1 - \sin \varphi)$.

Passive soil resistance is performance limit at the springline when a heavy surface wheel load crosses a pipe where soil cover is near minimum. The wheel load on the pipe increases horizontal pressure of pipe against sidefill. Soil slips on planes $\theta_s = 45^\circ - \varphi/2$. Passive soil resistance is sometimes evaluated by laboratory triaxial tests wherein a soil sample at constant horizontal pressure (interchamber pressure), is compressed vertically. The test provides uniaxial strength at soil slip. Uniaxial strength is sometimes assumed to be passive resistance to ring deflection at springlines. In fact, passive resistance under-pre-

dicts embedment soil strength. At the springline, as σ_y increases with height of cover, so does σ_x . The soil is compressed in two directions, vertical and radial, and is confined in one direction, longitudinal. This is biaxial compression for which strength is greater than uniaxial passive resistance. Tests show that slip planes do not occur at springlines. Vertical compression (strain) of the embedment is less than is predicted by laboratory tests. Another analysis is a heavy surface wheel load over the sidefill (but not over the pipe) such that σ_y is greater than σ_x .

At soil slip, $\sigma_x = \sigma_y / K$ is active soil resistance where $K = (1 + \sin \varphi) / (1 - \sin \varphi)$.

Slip planes develop at angle $\theta_s = 45^\circ + \varphi/2$ from horizontal. Soil could slip if pipe pressure, P_x against the sidefill, is less than σ_x , in which case, the pipe would fail inward at the springline. These extreme cases of active or passive soil slip are rare.

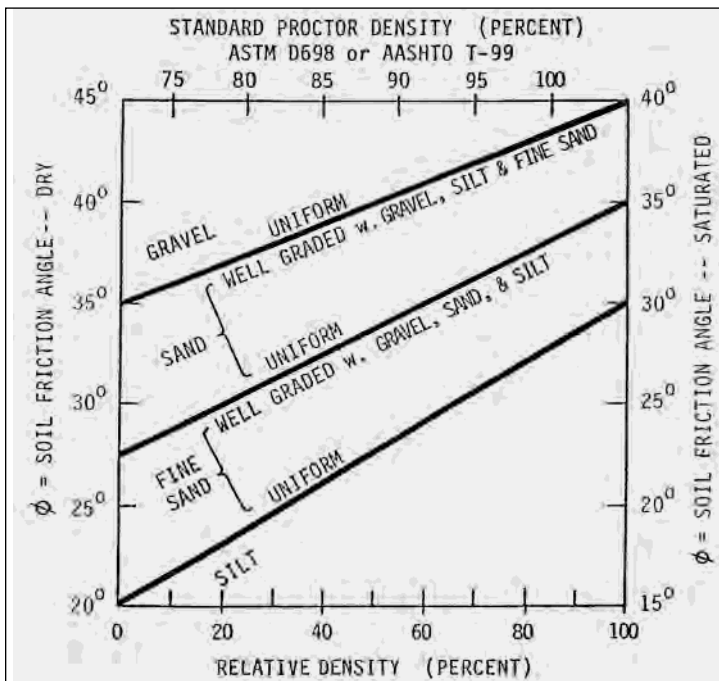

Figure 13. Conservative working values (lower limits) of soil friction angle, φ , for granular embedment (excluding crushed rock). The graphs are reduced from laboratory values to more typical field conditions that include non-uniform soils.

Soil Compression

Excessive soil compression is a performance limit. Vertical compression (strain) of sidefill soil causes ring deflection. Vertical sidefill strain is less than predicted by laboratory tests because biaxial stress at springlines causes less strain than does the uniaxial test stress. Nevertheless, laboratory tests are used conservatively for predicting ring deflection — which is roughly equal to (no greater than) vertical strain of sidefill.

Soil Density

Soil density is the dry unit weight of soil as a percent of the unit weight of the same soil compacted to 100% density, according to standard Proctor test ASTM D698 or AASHTO T-99. Density is achieved by compaction. Both soil strength and soil strain are functions of density.

Critical Density

Density is too low if saturated soil is so loose that it can liquefy when subjected to a sudden shock. Critical density is that density greater than which soil increases in volume when disturbed (shaken up). Soil strength is increased because volume is confined. At less than critical density, saturated soil decreases in volume (shaken down) when disturbed; and non-compressible water must support the load. The mass liquefies (turns to mud). As long as granular soil density is greater than about 85% Standard Proctor, it is above critical density and does not liquefy. Because critical density varies (soil types, permeability, degree of confinement and earth tremors), 90% Standard Proctor density (ASTM D698 or AASHTO T-99) is considered to be minimum critical density for soil below the water surface (water table).

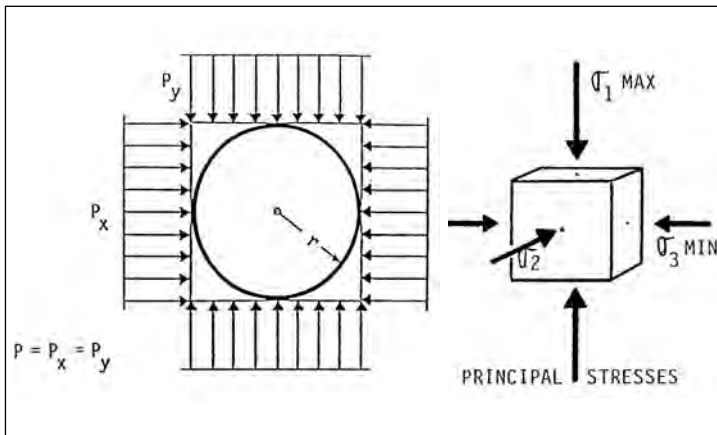

Figure 14. Flexible ring in equilibrium, subjected to external, radial pressure, P (left diagram), and principal stresses on an infinitesimal cube (right).

Pipe Mechanics

A flexible circular ring is in equilibrium when external pressure is uniform. Uniform pressure can be represented as shown in Figure 14. It is seldom necessary to combine or compound stresses. Shearing stresses are avoided by using principal stresses, σ_1 and σ_3 which are usually determinable. Intermediate stress, σ_2 , at right angles to σ_1 and σ_3 , is not critical. Stresses in the same direction are usually not combined. For example, σ_1 in the pipe wall is the sum of ring compression stress and ring flexure stress. But, performance limits are different for ring compression and ring flexure. Therefore, each is analyzed separately and compared to its own performance limit. For ring compression, performance limit is yield stress. For ring flexure, performance limit is excessive out-of-roundness. When buried, the basic out-of-round shape of the ring is an ellipse. See Figure 15. Other shapes may be superimposed on the ellipse. Loose soil under the haunches superimposes a triangle-shape on the ellipse. Heavy compaction on the sides tends to square the ellipse. But for most analyses, basic deformation is an ellipse, for which:

$$1. \quad r_y = r(1+d)^2/(1-d) \quad (11)$$

$$2. \quad r_x = r(1-d)^2/(1+d) \quad (12)$$

$$3. \quad \text{Ratio of radii is } r_r = r_y/r_x = (1+d)^3/(1-d)^3 \quad (13)$$

4. The cross sectional area of an ellipse is $A_e = \pi r^2(1-d^2)$. If ring deflection were $d = 5\%$, the reduction in cross sectional area of the pipe would be only a negligible 0.25%.
5. Soil pressures against the pipe are perpendicular to the pipe surface. It is conservative to neglect shearing stresses between soil and pipe. Shearing stresses break down due to vibrations caused by flow in the pipe, changes in temperature, rise and fall of the water table, earth tremors, etc. With no shear acting on it, a flexible ring is in equilibrium if Pr is constant all around the ring. Especially useful is the equation:

$$P_x r_x = P_y r_y \quad (14)$$

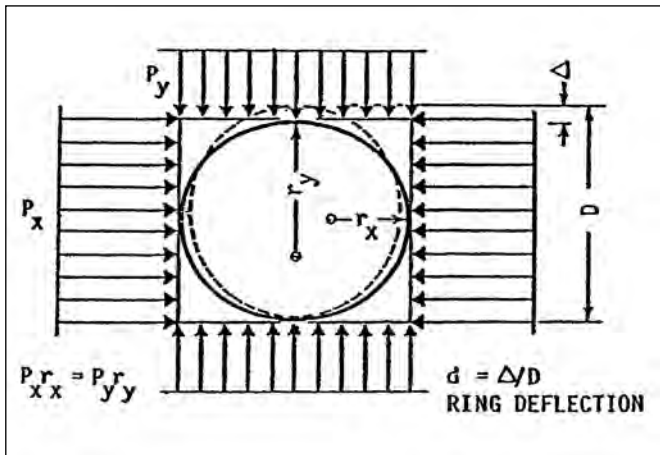

Figure 15. Pressure distribution diagrams show equivalent external radial pressures in equilibrium on a deflected flexible ring.

Example

A buried flexible pipe is deflected into an ellipse during backfilling. The measured ring deflection is 3%. The diameter is $D = 72$ inches (1,800 mm), and soil cover is $H = 4$ feet (1.2 m), unit weight of 120 pcf (19 kN/m³). What is the pressure of the pipe against sidefill at the springlines?

Pressure on top of the pipe is

$$P_y = (4\text{ft})(120 \text{ pcf}) = 480 \text{ psf (23.0 kPa)}.$$

From Equation 13, the ratio of radii is $r_y/r_x = 1.2$.

From Equation 14, $P_x = 576 \text{ psf (27.6 kPa)}$.

The sidefill soil only needs to resist 576 psf (27.6 kPa). If ring deflection were 10%, the sidefill would have to resist $P_x = 876 \text{ psf (41.9 kPa)}$ – easily resisted by granular sidefill. Because the required K is $876/480$, the minimum soil friction angle is $\varphi = 17^\circ$ at soil slip.

External Pressures and Loads

Pipe mechanics and soil mechanics are combined into pipe-soil interaction in the following.

1. Ring Compression Stress

Ring compression stress, $\sigma = Pr(1+d)/t$. P is pressure on top of the pipe. Performance limit is yield. If ring deflection, d , is not greater than 5%, it is negligible. For allowable stress, S , the minimum wall thickness is:

$$T = Pr/S \quad (15)$$

S includes a safety factor. When yield stress is exceeded, the ring is on the verge of wall buckling or crushing. The pipe does not collapse, but yield stress is considered to be a conservative performance limit. The soil must provide a margin of safety in the event of an unanticipated load. Internal pressure eliminates ring compression, but is neglected because there may be occasions when there is no internal pressure.

Example

A 72-inch (1,800 mm) plain pipe with 0.250 inch (6.35 mm) wall thickness is buried under $H = 4$ feet (1.2 m) of soil. A highway fill is to be placed over the pipe. Allowable stress in the pipe wall is $S = 21$ ksi (145 MPa). What is the maximum allowable height of fill over the pipe at soil unit weight $\gamma = 110$ pcf (17.3 kN/m³)? Substituting $P = \gamma H$ into Equation 15, and solving for maximum height of cover, $H = 191$ feet (58m). Clearly, maximum height of cover is not an issue for most buried steel pipe design. In fact, tunnel analysis may be more appropriate.

2. Ring Deflection

Because the ring is flexible, ring deflection of buried steel pipe is roughly equal to (no greater than) vertical compression (strain) of sidefill soil. The upper limit of ring deflection is:

$$d = \epsilon \quad (16)$$

where ϵ is the vertical soil strain predicted from laboratory compression tests. See Figure 16. For design of sidefill embedment, vertical strain ϵ should be no greater than allowable ring deflection, d .

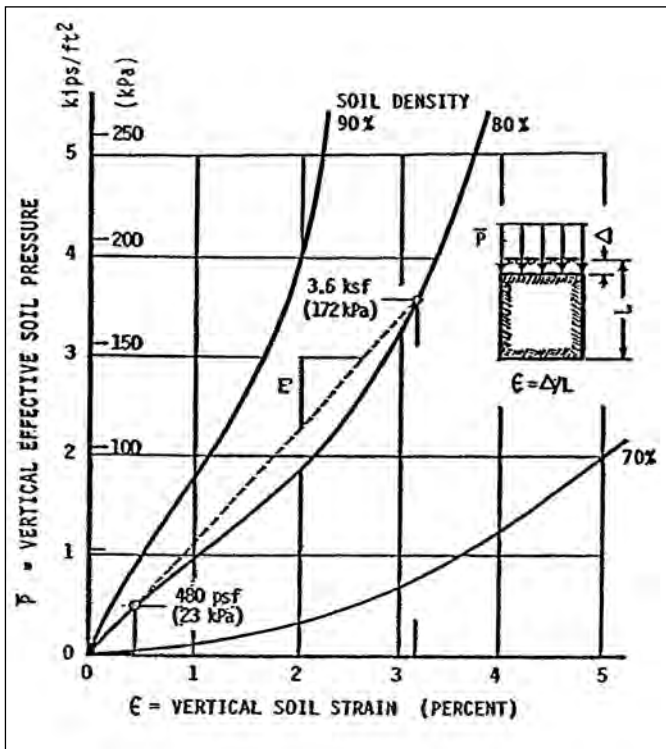

Figure 16. Examples of stress-strain data from confined compression tests on granular soil at three densities (ASTM D698 or AASHTO T-99), showing the soil modulus (slope of secant), in 80% dense soil, $E' = 788$ psi (5.43 MPa) for a soil pressure increase from 480 psf (23 kPa) to 3,600 psf (172 kPa). E' is vertical modulus that is useful for ring deflection analysis. In the Iowa formula E' is a horizontal modulus.

A stiff ring resists compression of the soil. Figure 17 shows the ring deflection term, d/ϵ , as a function of stiffness ratio, $E'/(EI/r^3)$ where E' is vertical soil stiffness, and ring stiffness is

$$(EI/r^3) = [(2E/3)/(D/t)^3] \text{ for plain pipe.}$$

The stiffer the ring, the smaller the ring deflection. Ring stiffness, when defined as EI/r^3 , applies to a deflected ring where r is the maximum radius of curvature. For a circular ring, $EI/r^3 = 8EI/D^3$, where EI/D^3 is a common expression for ring stiffness.

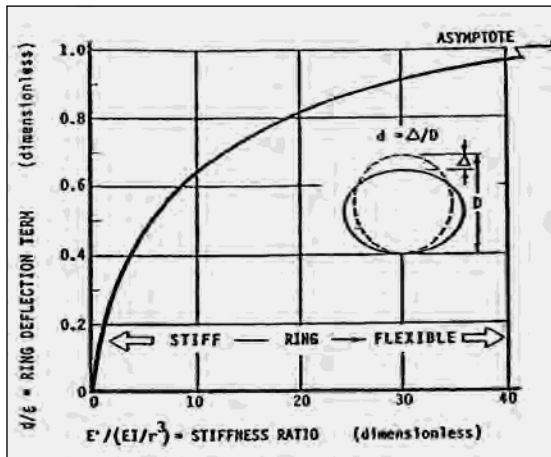

Figure 17. Graph of ring deflection term as a function of stiffness ratio from tests. Ninety percent of all data falls below the graph.

Example

A 72-inch (1,800 mm) steel pipe with 0.250 inch (6.35 mm) wall is embedded in granular soil at 80% density (ASTM D698 or AASHTO T-99), with soil cover $H = 4$ feet (1.22 m). Soil density less than 90% is not usually specified. During installation, ring deflection was controlled – essentially zero – so 80% density was not critical. But now it is proposed to increase soil cover to a height of $H = 30$ feet (9.14 m). Soil unit weight is 120 pcf (19 kN/m³). What is the predicted ring deflection of the pipe? Initially, $P = 480$ psf (23 kPa). The final $P = 3,600$ psf (172 kPa).

From Figure 16, soil strain from 480 psf to 3,600 psf on the 80% density graph is

$$\epsilon = (3.15\% - 0.4\%) = 2.75\%.$$

E' is the slope of the secant from 480 to 3,600. Therefore $E' = 788$ psi (5.43 MPa). Ring stiffness is $EI/r^3 = 0.79$ psi (5.4 kPa). Stiffness ratio is $E'/(EI/r^3) = 1,000$. The ring deflection term, d/ϵ is found by entering Figure 17 with stiffness ratio, 1,000, which falls off the chart. Therefore, $d/\epsilon = 1$, and ring deflection is no greater than $d = 2.75\%$, or say, 3%.

For a standard AWWA C-205 mortar-lined-and-coated pipe, ring stiffness = 1.68 psi, the stiffness ratio, $E'/(EI/r^3) = 470$, also falls off the chart.

Clearly, lined-and-coated pipe is flexible.

Suppose allowable ring deflection is 5%. What would happen if 5% were exceeded a bit? Nothing, because ring deflection, per se, is not structural

failure. But because ring deflection is understood and can be measured, and can be controlled by soil compaction, 5% is often specified as maximum allowable. For flexible pipe, stiffness ratio falls off the chart of Figure 17, so the maximum ring deflection is $d = \epsilon$. For the stiffness ratio of a 72-inch (1,800 mm) plain pipe to fall on the chart of Figure 17, for example, $E'/(EI/r^3) = 40$, the wall thickness would have to be 0.72 inch (18 mm), for which ring flexibility is $D/t = 100$. If D/t is less than 100, or if the embedment is poor (low soil stiffness), the stiffness ratio could be less than 40. Figure 17 can be used to predict ring deflection under such conditions. Unless conditions justify different values for ring deflection, allowable is usually specified as 5%. Constructors can meet specifications by compacting the sidefill soil or by using select embedment which, without compaction, compresses less than the allowable ring deflection. Soil cement slurry (flowable fill) is sometimes used to assure support under the haunches.

Ring Stability

Ring stability is resistance to collapse of the pipe when it is subjected to internal vacuum and/or external hydrostatic pressure. Clearly, the conditions for collapse occur only if the pipe is not pressurized. Therefore, the potential for collapse is remote, and the need for analysis of ring stability is remote. The following analyses are applicable only under loss of internal pressure that is replaced by internal vacuum and/or external water table above the pipe. Both cause negative pressure in the pipe.

1. Without Soil Support

The classical equation for collapse of a “ring” subjected to uniform external pressure, P , is $Pr^3(1-\nu^2)/EI = 3$. Poisson ratio for steel is $\nu = 0.3$. For a steel “ring”, $PD^3/EI = 26.37$ discounting longitudinal stress. In a “pipe” with longitudinal stress, it is common practice to use a conservatively lower value of collapse pressure, P , by ignoring the square of Poisson ratio,

$$PD^3/EI = 24 \quad (17)$$

For a circular plain pipe, $I = t^3/12$, and Equation 17 reduces to:

$$(P/E)(D/t)^3 = 2 \quad (18)$$

where P is external collapse pressure. Collapse occurs only when an empty pipe is immersed in water or grout, or when a vacuum occurs inside an unburied pipe, or when the pipe is buried in soil that liquefies. In fact, from tests, an embedment of mud provides enough soil strength that collapse pressure, P , is about twice as great as the predicted values from theoretical Equations 17 and 18.

Example

What is maximum D/t for unburied plain pipe subjected to atmospheric pressure (vacuum) of P = 14.7 psi (101 kPa)? E = 30,000,000 psi (207 GPa). From Equation 18, D/t = 160.

The contribution of mortar lining and coating to an increase in critical pressure is significant. Table 2, page 24, shows the increase in ring stiffness as a result of mortar linings and coatings.

2. With Soil Support and No Water Table or Internal Vacuum

A conservative performance limit is soil slip (passive resistance) at spring-line. Figure 18 shows an infinitesimal cube of soil, B. At soil slip, the pressure of the pipe against the soil is equal to passive soil resistance.

$$Pr_r = K\sigma_y \tag{19}$$

P is vertical soil pressure at the top of the pipe; and $r_r = r_y/r_x = (1+d)^3/(1-d)^3$ reflects elliptical ring deflection.

From Equation 19, ring deflection, d, can be found at soil slip. Analysis by passive resistance is conservative because the biaxial stress resistance at springline is greater than the uniaxial passive resistance from theory or from tests. Moreover, the ring deflection is never perfectly elliptical.

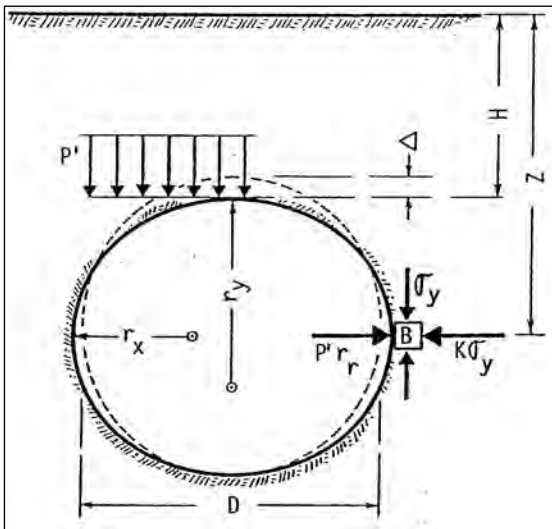

Figure 18. Buried flexible ring showing stresses on an infinitesimal cube B.

Example

Based on passive resistance analysis, find the ring deflection at sidefill soil slip if D = 72 inches (1,800 mm) and H = 4 feet (1.2 m). Embedment is granular, loose soil.

Unit weight is $\gamma = 100$ pcf (15.7 kN/m³).

The soil friction angle is $\phi = 15^\circ$ from which, $K = (1+\sin \phi) / (1-\sin \phi) = 1.7$.

$P = \gamma H = 400$ psf (19.15 kPa).

$\sigma_y = \gamma Z = (100 \text{ pcf})(4 \text{ ft} + 3 \text{ ft}) = 700$ psf (33.5 kPa).

For a first trial, let Z = 7 ft (2.13 m). Substituting these values into Equation 19, $Pr_r = (400 \text{ lb/ft}^2) (1+d)^3/(1-d)^3 = 1,189 \text{ lb/ft}^2 (56.93 \text{ kPa}) = K\sigma_y$.

Solving, $d = 18\%$. For a second trial, let $Z = 4 \text{ feet} + 2.5 \text{ feet} = 6.5 \text{ feet}$ (2.0 m) to account for the 18% reduction in vertical diameter of the deflected ring. This solution yields $d = 17\%$. From an old assumption, the ring is at incipient inversion when $d = 20\%$.

The above analysis is conservative because passive resistance is less than sidefill soil resistance, and ring stiffness is ignored. Ring stiffness is included in Figure 19, which shows pressure at soil slip as a function of ring deflection and sidefill soil friction angle. It is assumed that soil cover is high enough that H is essentially equal to Z . Two important conclusions follow. Compaction of the embedment has a significant effect on pressure, P , at soil slip. Soil does not slip if ring deflection is less than 10%. Therefore, maximum allowable ring deflection is usually limited by specification to 5%.

Example

If height of cover is $H = 12 \text{ ft}$ (3.7 m), what is the ring deflection at soil slip? $D = 72 \text{ inches}$ (1,800 mm) and $t = 0.250 \text{ in}$ (6.35 mm), $D/t = 288$. The embedment is loose soil for which $\gamma = 100 \text{ pcf}$ (16kN/M³).

The soil friction angle is assumed to be $\phi = 15^\circ$ because the soil is of poor quality, $EI/r^3 = 0.78 \text{ psi}$ (5.4 kPa). $P = 1200 \text{ psf} = 8.3$ (57 kPa).

The soil pressure term is $P/(EI/r^3) = 10.7$. From Figure 19, $d = 11\%$. No problem is anticipated if ring deflection is less than 5%. When ring deflection is significant, EI/r^3 replaces $8EI/D^3$ where r is the maximum radius of curvature.

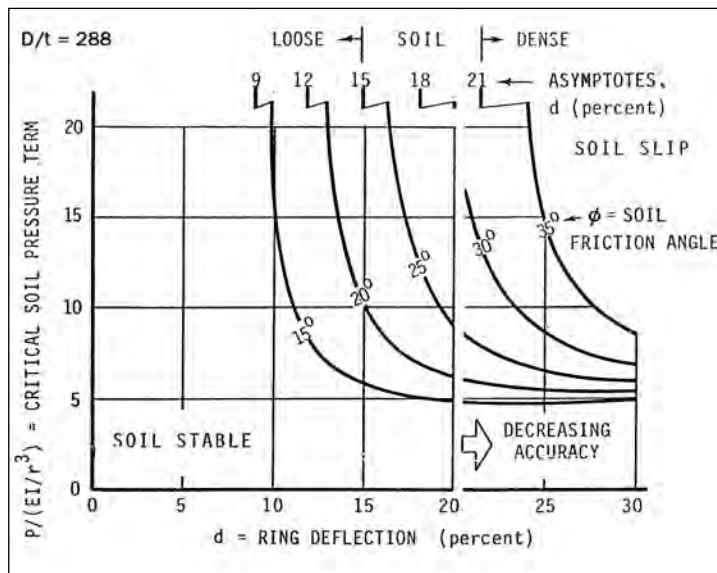

Figure 19. Soil pressure term at soil slip as a function of ring deflection, d , in sidefill soil compacted to soil friction angle ϕ — conservative because sidefill is compressed biaxially. Sidefill is granular. Water table is below the pipe.

3. With Soil Support and Internal Vacuum — Unsaturated Soil

The performance limit for internal vacuum is ring inversion (reversal of curvature). Critical vacuum, p , is a function of radius of curvature. Because the maximum radius of curvature, r_y , is greater than r , the ring stiffness, EI/r_y^3 , is less than EI/r^3 , and vacuum, p , at collapse is reduced. See the next page for notation. From Figure 18, critical vacuum, p , is found by equating horizontal stresses at B.

$$P(r_r - 1) = K\sigma_y - (P - Ed/m^3)r_r \quad (20)$$

Figure 20 shows graphical solutions of Equation 20 for ring deflection up to $d = 15\%$ in soil with friction angles from 15° to 45° , and values of $D/t = 192$ and 288 .

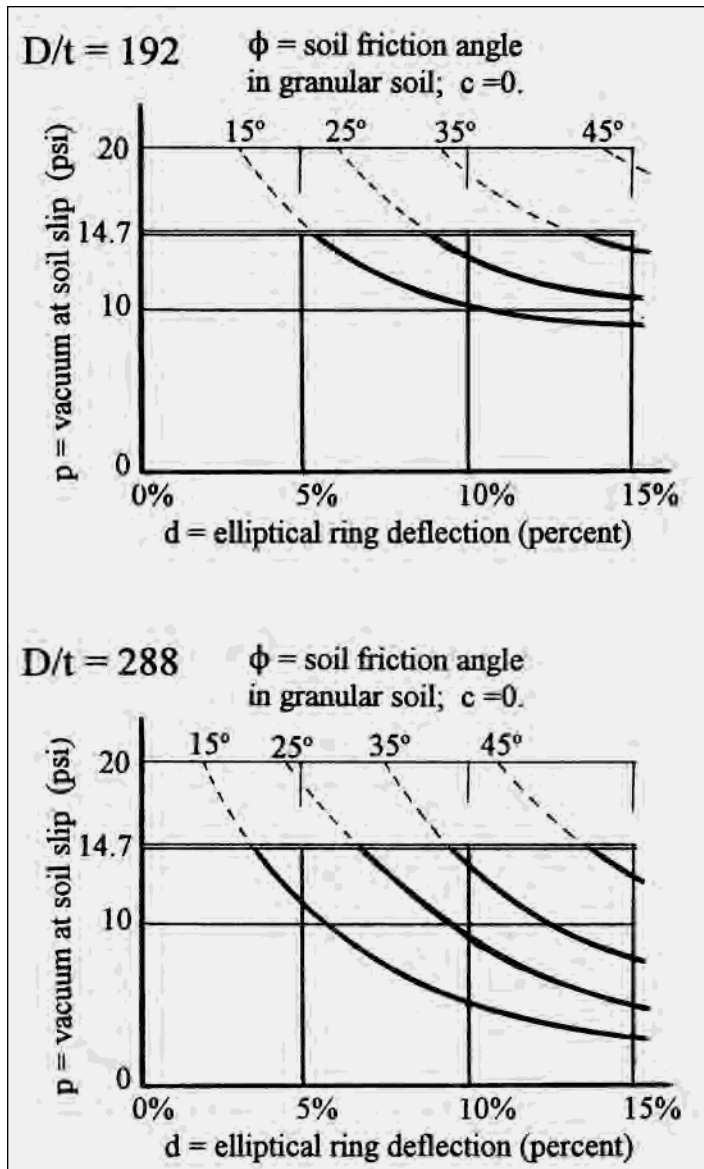

Figure 20. Internal vacuum, p , at collapse.

$D = 48$ inches (1200 mm)

$H = 36$ inches (900 mm)

$K = (1 + \sin\phi)/(1 - \sin\phi)$

$\gamma = 100$ pcf = soil unit weight

1 psi = 6.9 kPa

4. With Soil Support and With Water Table Above the Pipe — Saturated Soil

When the water table is above the pipe, the embedment soil will not liquefy if density is 90% Standard Proctor (ASTM D698 or AASHTO T-99). The external hydrostatic pressure, due to the height of the water table, must be added to the internal vacuum. Worst case is an empty pipe submerged under water – such as a river crossing or a flood. See Figure 21. Using the stability analysis of Figure 18, but including ring stiffness, vacuum and external hydrostatic pressure, the equation of stability in saturated soil is:

$$p(r_r - 1) = K\sigma_y + u_B - (P_A + \pi r \gamma_w / 2 - Ed/m^3)r_r \quad (21)$$

where

p	=	vacuum and/or external hydrostatic pressure at springline
σ_y	=	effective vertical soil stress at springline
P	=	total vertical pressure on top of the pipe
K	=	$(1 + \sin \varphi) / (1 - \sin \varphi)$
φ	=	soil friction angle
u_B	=	water pressure at springline = $(h + H + r)\gamma_w$
H	=	height of soil cover
h	=	height of water table above the ground surface
γ_w	=	unit of weight of water = 62.4 pcf (9.8 kN/m ³)
E	=	modulus of elasticity of steel = 30,000,000 psi (207 GPa)
d	=	ring deflection (ellipse assumed) = Δ/D
D	=	diameter of the pipe
m	=	r/t = ring flexibility = $1/2 (D/t)$
r	=	$D/2$ = radius of the circular pipe
t	=	wall thickness of plain pipe
r_r	=	r_y/r_x

The term, $(\pi r \gamma_w / 2)$, is uplift pressure equivalent to buoyancy of the empty pipe. If the pipe is full of water, this term is eliminated from Equation 21. Noteworthy observations are:

- The conditions for instability of steel pipe are remote.
- The most significant variables are ring deflection, d , and soil density (soil friction angle, φ).
- A water level above the pipe lowers soil support and critical vacuum.
- The effect of D/t on critical vacuum is minor, especially for values of D/t greater than 240.
- Increase in soil cover, H , raises the critical vacuum slightly.

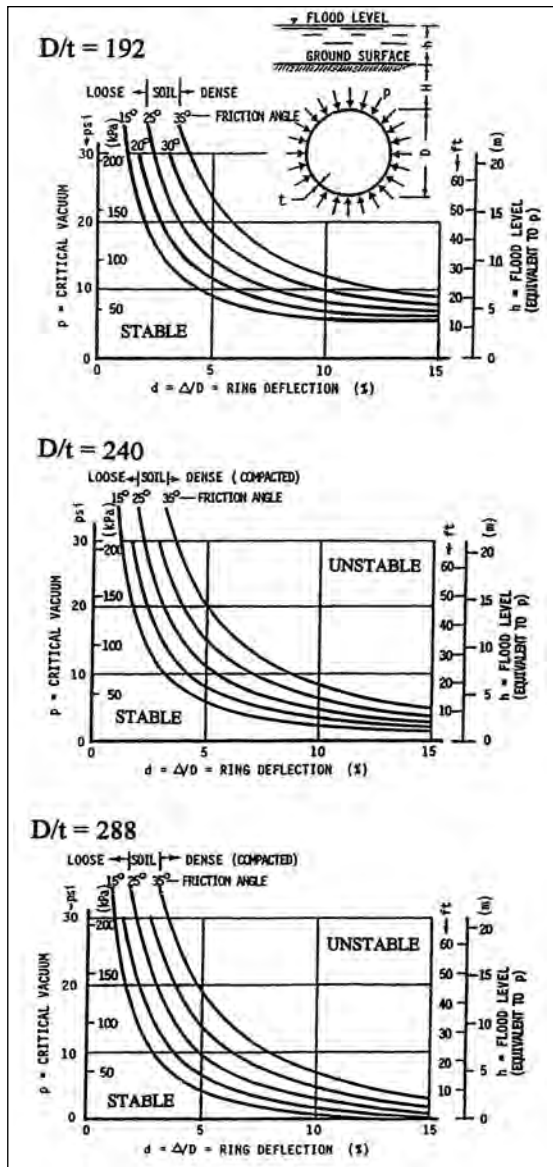

Figure 21. Examples of critical vacuum as a function of ring deflection and soil friction angle — in SATURATED SOIL at 125 pcf (19.6 kN/m³). D = 51 inches (1,275mm), H = 3 feet (0.9 m).

Example

What is critical vacuum, p, in an empty pipe buried in soil saturated to the ground surface if ring deflection is d = 5% elliptical?

H = 3 ft = soil cover
H+r = 5.125 ft to springline
D = 51 in, t = 0.177 in, D/t = 288
m = r/t = 144; d = 0.05; E = 30(10⁶) psi
Ed/m³ = 0.502 psi
r_r = 1.35 = (1+d)³/(1-d)³ = r_y/r_x for ellipse
γ = 125 pcf = saturated unit weight of soil
γ_b = (125-62.4) pcf = 62.6 pcf buoyant
φ = 15°; K = 1.698 = (1+sinφ)/(1-sinφ)
σ_y = 5.125(62.6) psf = 2.228 psi
Kσ_y = 3.783 psi
u_B = 5.125(62.4) psf = 2.221 psi water pressure at springline
πrγ_w/2 = 1.446 psi where r = 2.125 ft and γ_w = 62.4 pcf = unit weight of water

Substituting values into Equation 21, the critical vacuum (at ring collapse) is, p = 3.5 psi
From the less-precise graph of Figure 21, D/t = 288, d = 5%, and φ = 15°, p = 4 psi

If the embedment were compacted such that φ = 35°, from Figure 21, graph of D/t = 288, critical vacuum is p = 18 psi which is equivalent to a flood level of 42 ft above ground surface. But if the ring deflection happened to be d = 10%, from Figure 21, the critical vacuum is only 7 psi or an equivalent flood level of 16 ft above ground surface.

Flotation

An empty pipe will float if the water table is above the pipe and the soil cover is inadequate. Worst case is a water table, at, or above, ground surface. For a one foot thick slice of cross section, the buoyant uplift force in pounds is $\pi D^2 \gamma_w / 576$, which must be resisted by the buoyant weight of the soil wedges. See Figure 22. The wedge slip planes are at $\theta_s = 45^\circ + \phi/2$. Buoyant unit weight is $\gamma_b = \gamma_{sat} - \gamma_w$ (saturated unit weight of soil minus unit weight of water). The resistance to flotation is the area of the soil wedge above the pipe, times its buoyant unit weight. In general, the height of cover should be greater than $H = D/2$. The soil should be denser than critical density in order to prevent soil liquefaction as the pipe starts to move up. The minimum specified density is generally 90% (ASTM D698 or AASHTO T-99).

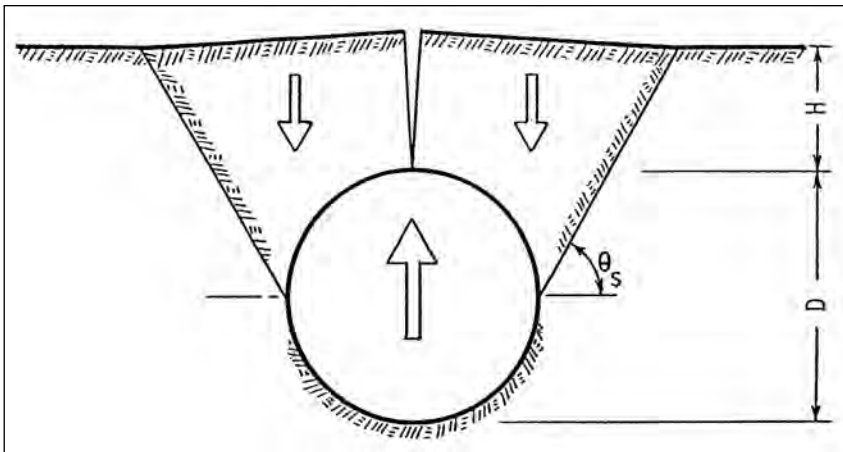

Figure 22. Flotation of a pipe, showing the reaction of soil wedges to the buoyant uplift force of an empty pipe buried below the water table under less than minimum cover.

Minimum Soil Cover

Minimum soil cover is of greatest concern during installation when live loads pass over the pipe before the pipe is pressurized.

H is the height of soil cover above the top of pipe to the bottom of the wheel load passing over. See Figure 23. Soil cover is minimal if soil slip planes reach the unpressurized pipe and invert it under a truncated soil pyramid punched through by wheel load, W. The loaded surface area is the tire print. For an HS-20 dual wheel, the tire print is roughly a rectangle 7 x 22 inches (178 x 559 mm) at 105 psi (724 kPa) tire pressure. In granular soil, the angle of the slip planes is approximately 1h:2v. For a dual wheel, pressure at the top of the pipe is $P = W / [(B+H)(L+H)]$ where B and L are dimensions of dual tire print. Dead load is neglected because it is small at minimum cover, and is balanced. Dead load left of centerline, is balanced by dead load right of centerline.



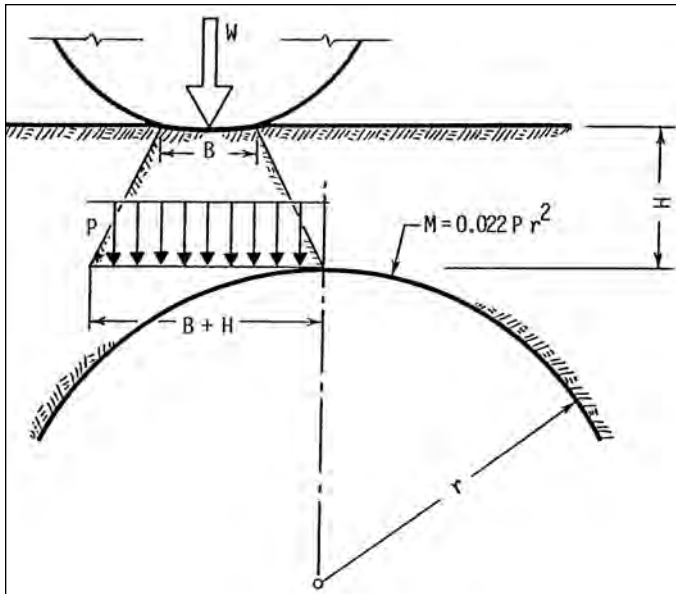

Figure 23. Conditions for inversion of the top of an unpressurized pipe due to a surface wheel load and a minimum cover, H, showing the truncated pyramid punched through to the pipe, and showing the maximum moment, M.

The critical location of pressure P for ring inversion is on one side of centerline as shown. Maximum moment occurs on the opposite side, and, from analysis by Castigliano's equation, is located about 12° from the centerline. The maximum moment, is:

$$M = 0.022Pr^2 \quad (22)$$

From theory of elasticity, at an allowable stress, S: $M = Sl/c$ where l/c is the wall section modulus. Substituting into Equation 22, the *minimum* required l/c is:

$$(l/c)_{\min} = Pr^2/45S \quad \text{ELASTIC THEORY} \quad (23)$$

For plain pipe, stress due to the bending moment is $\sigma = 6M/t^2$ from which the required pipe wall section modulus is $t^2/6 = M/S$. Solving for M and substituting into Equation 22, $t^2S = 0.132Pr^2$. From this the *maximum* allowable ring flexibility, D/t is:

$$(D/t)_{\max}^2 = 30S/P \quad \text{ELASTIC THEORY – Plain Pipe} \quad (24)$$

where

- P = $W/(B + H) (L + H)$ = punch-through live load pressure on the pipe
- S = allowable stress in the steel

At formation of a plastic hinge, the plastic moment is 1.5 times the elastic moment. Equations 23 and 24 become:

$$(l/c)_{\min} = Pr^2/68S \quad \text{PLASTIC THEORY} \quad (25)$$

$$(D/t)_{\max}^2 = 45S/P \quad \text{PLASTIC THEORY – Plain Pipe} \quad (26)$$

The plastic theory implies that as the wheel passes over the pipe, the top of the pipe could begin to buckle even though the pipe does not collapse. In fact, the pipe ring may not even be deformed because of its longitudinal beam strength.

Example

What is the minimum granular soil cover over a plain pipe if $D/t = 274$, $D = 51$ inches (1,275 mm), $t = 0.187$ inch (4.75 mm) and $S = 42$ ksi (290 MPa)?

The live load is $W = 16$ kips (71 kN) on a dual wheel with a rectangular tire print, $B = 7$ inches (178 mm) and $L = 22$ inches (559 mm). The soil is compacted; no ruts are left by the passing wheel.

Using plastic theory, Equation 26, critical $P = 25$ psi (174 kPa).

The actual P under the truncated pyramid is $P = 16,000 \text{ lb}/[(7+H)(22+H)]$.

Equating the two values of P and solving, $H = 11.8$ inches (300 mm). Safety factors are ample because every step in the analysis is conservative. If soil compaction is not assured, pipeline engineers usually call for a minimum cover of 3 feet (0.9 m). If the ground surface is paved, the effective loaded surface area, $L \times B$, may be increased depending upon type and thickness of pavement.

Trench Conditions

The predominant pipe-soil interaction is between pipe and embedment, not between pipe and trench walls. Properties of the native (in-situ) trench walls and dimensions of the trench are subdominant — with the following caveats:

1. Buried pipe can be affected by: differential subgrade settlement, landslides, sidehill soil, creep, soil liquefaction and slip on seismic faults. The native soil must maintain the shape and alignment of the pipe.
2. OSHA guidelines must be complied with in trench configurations.



Trench Shield

When trench walls are retained by sheet piling or a trench shield (trench box), voids could be left when the retainer is pulled. The pipe is not affected if the bottom edge of the retainer is above the spring line. Even if embedment soil slips into the voids, the slip planes are on a slope that does not intersect the pipe. In a narrow trench, if the bottom of the retainer is below springline, when it is pulled, the voids below springline could possibly be filled by jetting, injecting, grout, vibrating, etc. The pipe is not affected if the trench wall soil slips in against the embedment; but if the embedment slips out against the trench wall, ring deflection of the pipe could increase.

Trench Width

In general, the trench should be narrow — just wide enough for alignment of the pipe and for placement of soil embedment. Because $P_r = P_x r_x = P_y r_y$, as long as the ring is nearly circular, sidefill support only needs to be equal to the pressure P on top of the pipe. Theoretically, the soil can be liquid (no strength) if the ring is circular.

Practically, if the trench is excavated in poor soil, a good practice is to place good embedment to a width of half a pipe diameter on each side of the pipe. It is presumed that ring deflection will be less than 5%. Trench wall support of the embedment is active pressure only. Minimum trench width is sometimes specified to be two pipe diameters in poor native soil with low-bearing capacity (< 4 blow counts). Two special cases follow.

If the pipe is deflected into an ellipse, the required side support is, from Equation 19, $P_x = P_r = K\sigma_y$. For good sidefill, K equals 3 or more. At springline, σ_y is greater than P on top of the pipe, but it is assumed, conservatively, that $\sigma_y = P$. At soil slip, $r_r = 3$. Equating horizontal stresses, and solving, the elliptical ring deflection is 18%. Clearly, 18% is unacceptable for other reasons than trench width. Wide trenches are not necessary.

Example

In Figure 24, ring deflection is $d = 5\%$ for which $r_r = [(1 + d)/(1-d)]^3 = 1.35$. Pressure on top is P . Therefore, $P_x = P_r = 1.35P$. In this case, the sidefill cover is a narrow $X = D/5$. If the granular sidefill soil slips, shear planes slope at 1v:2h. From geometry of the sidefill wedge, the area of contact of wedge on trench wall is roughly 1.5 times the contact area of pipe on wedge. Consequently, pressure on the trench walls is $1.35(2P/3) = 0.9P$. High bearing capacity is not a prerequisite of the trench walls. This rationale is crude because pressure against the trench wall is not uniform, but a more accurate pressure distribution is offset partially by longitudinal soil arching action that is neglected.

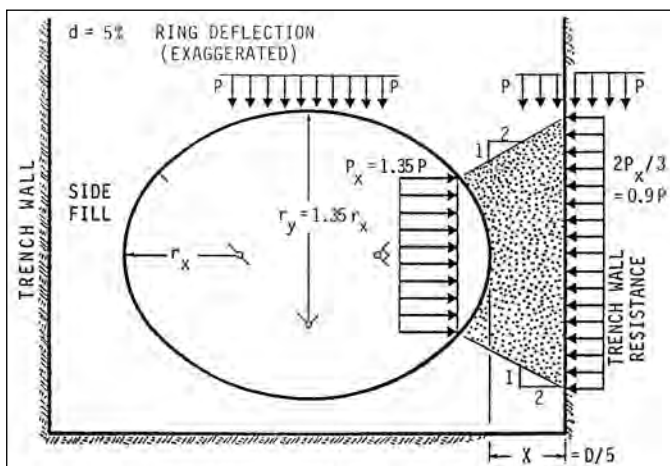

Figure 24. Trench wall support required for flexible stability, showing the sidefill wedge at soil slip. In this case, ring deflection is $d = 5\%$ and width of sidefill is $X = D/5$. In this worst-case example, and in general, the required trench wall resistance is less than pressure P on the pipe.

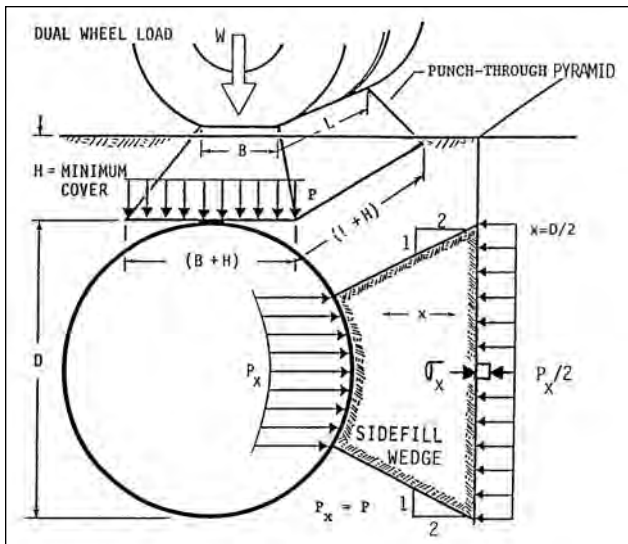

Figure 25. Trench wall support required for ring stability when a wheel load passes over a circular, flexible pipe with less-than-minimum soil cover. The small support provided by poor soils is adequate.

Of greater concern is surface live load. Figure 25 shows a dual wheel passing over an unpressurized pipe with minimum soil cover. A truncated pyramid is punched through.

The pipe feels pressure, $P = P_d + P_l$, where $P_l = W/(B + H)(L + H)$.

If the ring is nearly circular, $P_x = P$. In Figure 25 it is assumed that P_x is great enough to punch out a sidefill wedge against the trench wall. The sidefill wedge forms within 90° of pipe arch along slip plane slopes of 1 vertical to 2 horizontal. If width of sidefill is $X = D/2$, the contact area of wedge on trench wall is $\sigma_x = P_x/2 = P/2$, which must be resisted by the trench wall. If a pyramid punches through soil cover that is less than minimum, the design is unacceptable regardless of trench width. This analysis is conservative because longitudinal beam resistance of the pipe is neglected.

Example

In Figure 25, the pipe diameter is $D = 51$ inches (1,275 mm), $t = 0.187$ inch (4.75 mm) and ring deflection is negligible.

The soil unit weight is $\gamma = 100$ pcf (15.7 kN/m³). There is no water table.

Sidefill width is $X = D/2$. The soil cover is $H = 2$ feet (0.6 m). If an HS-20 dual wheel load of 16 kips (71 kN) passes over, what soil friction angle is required in the trench wall to prevent soil slip at the springline? Because H is greater than minimum soil cover, a pyramid does not punch-through. However, the pipe feels the live load pressure.

From Boussinesq,

$P_l = 0.477 W/H^2 = 1,908$ psf (91 kPa). $P_d = 200$ psf. $P = 2,108$ psf.

For a circular flexible ring, $P_x = P$. From Figure 25, $\sigma_x = P_x/2 = 1,054$ psf.

At springline $\sigma_y = 413$ psf. $K = \sigma_x/\sigma_y = 1,054/413 = 2.55$.

But $K = (1 + \sin\phi)/(1 - \sin\phi)$. Solving, $\phi = 26^\circ$ required in the trench walls. Additional safety factor is not needed.

If H is increased to 2.5 feet (0.75 m), $\phi = 13^\circ$. With soil cover of 2.5 feet, if the trench wall can support the HS-20 wheel load, surely its friction angle is high enough to prevent soil slip. If H is increased to 3 feet (0.9 m), $\phi = 3^\circ$.

The above analyses apply to soil cover greater than minimum. At minimum cover, $H = 11.8$ inches (300 mm), a truncated pyramid is punched through by the wheel load, and

$$P_l = 3,626 \text{ psf. } P_d = 98 \text{ psf.}$$

$$\sigma_x = 1,862 \text{ psf, } \sigma_y = 311 \text{ psf and } K = 5.987 = (1 + \sin\phi)/(1 - \sin\phi).$$

$$\text{Solving, } \phi = 45.5^\circ.$$

Dense, excellent soil is required in the trench wall. However, the analysis is moot because performance limit is now the minimum cover H — not the trench wall.

The above analyses are based on soil with no cohesion. Many trenches are excavated in soil with enough cohesion to stand in vertical cut. In such cases, the above analyses are conservative. Cohesion increases soil strength. After the pipe is pressurized, trench width analyses are moot.



For parallel pipes, stability is sensitive to soil density.

Parallel Trench

When a trench is excavated parallel to a buried flexible pipe with no internal pressure to hold it in shape, the question arises, how close can the trench come to the buried pipe? At less than minimum side cover, X, side support is lost and the prism of soil on top of the pipe must be supported by the pipe. If ring stiffness is inadequate, the pipe will collapse. See Figure 26. Critical conditions are a flexible ring and a parallel trench with vertical walls. Soil strength can be measured by excavating a test trench. The depth, Z, at which the trench walls start to slough in, is a measure of soil strength. Z can be found on site by a backhoe, or it can be calculated. See texts on geotechnical engineering.

From tests, $(X/D) = 1.4 (H/Z)$. With ample safety factor for design, minimum X is found from the expression:

$$(X/D) = 3(H/Z) \tag{27}$$

Embankment Over a Pipe

Under an embankment, soil cover of $D/2$ provides adequate protection. See Figure 27. These parallel trench analyses are conservative, and apply only before the pipe is pressurized.

Parallel Pipes

One performance limit for buried, flexible, parallel pipes is soil slip between the pipes. See Figure 28. Section A-A is critical before the pipes are pressurized. Section A-A is the cross section of a slice of the soil column that supports dead weight, Q_d , shown cross-hatched, plus the effect of live load, $Q_l = P_l X$, where P_l is the pressure at depth $H + r$ according to Boussinesq.



Total load on Section A-A is $Q = Q_d + Q_l$, of which steel pipe walls carry PD where P is dead load pressure at the top of the pipes. The remainder, $Q - PD$, is supported by the soil. Horizontal stress in the soil is the horizontal pressure of the pipes against the soil, $\sigma_x = P_x$.

The vertical stress is $\sigma_y = (Q - PD)/X$.

Knowing that $\sigma_y/\sigma_x = K = (1 + \sin\phi)/(1 - \sin\phi)$, the required soil friction angle, ϕ , can be calculated.

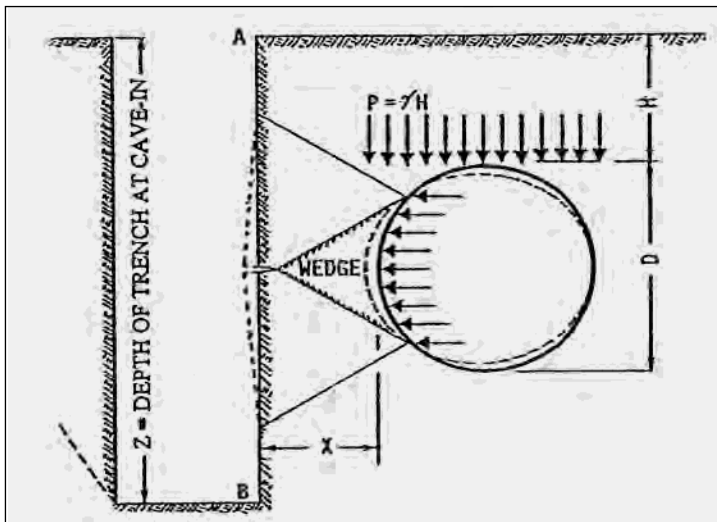

Figure 26. Vertical trench wall parallel to a buried flexible pipe, showing the soil wedge and shear planes that form as the pipe collapses.

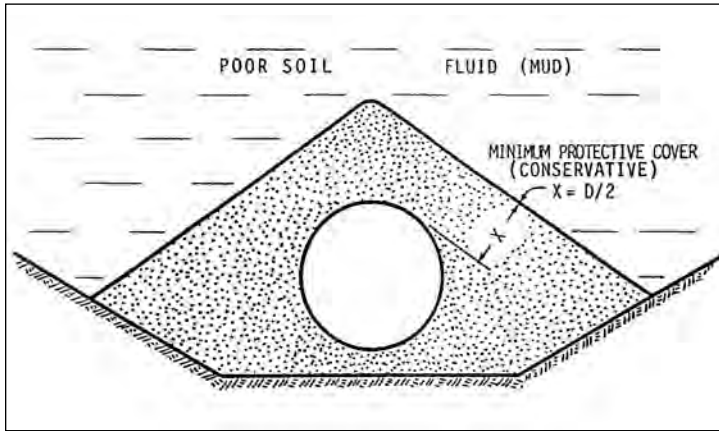

Figure 27. Minimum cover of embedment over a pipe in either an embankment or a trench with sloping walls.

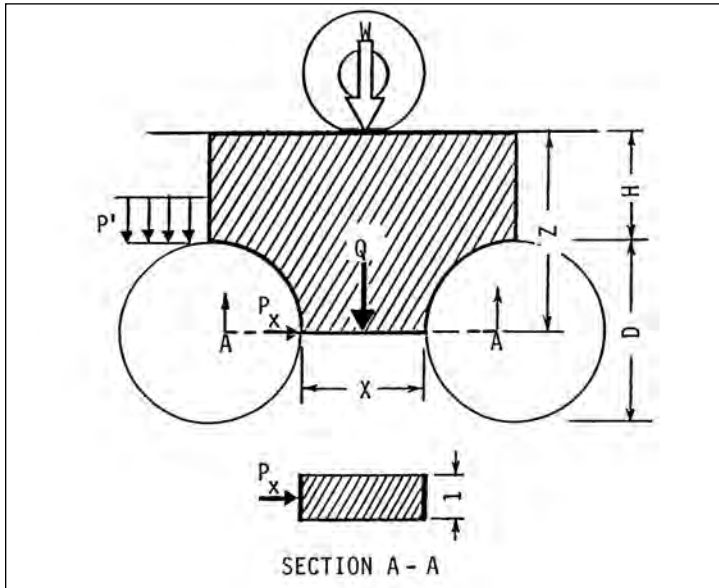

Figure 28. Load, Q , on a soil column Section A-A between parallel flexible pipes.

Example

Two parallel 51-inch (1,275 mm) pipes are separated by $X = 3$ feet (0.91 m) under soil cover of $H = 2.75$ feet (0.84 m). What is the maximum dual wheel load, W , that can pass over the pipes before they are pressurized? The soil is granular without cohesion, well compacted with unit weight of 120 pcf (18.8 kN/m³). Soil friction angle is $\phi = 37^\circ$. Depth of Section A-A is $Z = 4.875$ feet (1.486 m). See Figure 28. The load on Section A-A is dead load plus live load.

Dead load weight of soil (cross-hatched) is $Q_d = 3,390$ lb/ft (50 kN/m).

Live load pressure at depth Z is $P_1 = 0.477W/Z^2 = W/49.82$ ft².

Live load on column Section A-A is $Q_1 = X P_1 = W/16.6$ feet.

Total load on the column is $Q = Q_d + Q_1$.

Load carried by the pipe walls is PD feet = 1,400 lb/ft.

Vertical stress on the soil column is $\sigma_y = (Q-PD)/X$.

Horizontal stress is the pressure of the pipe against the soil column; i.e., $\sigma_x = P_x = P = 330$ lb/ft². At soil slip, $\sigma_y/\sigma_x = K = 4$.

Solving, $W = 33$ kips (146 kN).

With no live load, soil slips at the springline if X is less than

$$X = 0.43r^2/[H(K-1)-r] \quad (28)$$

For the pipe in this example, minimum separation is $X = 3.8$ inches. If ϕ is 15° then $X = 9.2$ inches. Clearly, stability is sensitive to soil density. The analysis is conservative because ring stiffness and longitudinal beam action are both neglected, and the piping is not pressurized.



Longitudinal Analysis

Following are four longitudinal stress analyses: thrust restraint, longitudinal contraction (expansion), beam action and pipe on piles.

1. Thrust Restraint

Longitudinal thrust is caused by internal pressure and change in direction of flow. Thrust also occurs at special

sections such as valves, elbows, wyes, tees, reducers, etc. A large thrust occurs at 90° elbows. With pressure in the pipe, a cap or closed valve causes thrust with longitudinal stress of $\sigma_z = Pr/2t$ in the pipe. This longitudinal stress is, at most, only half as great as the circumferential hoop stress. Thrust must either be resisted by the pipe itself (welded joints) or by external restraints such as thrust blocks, anchors and embedment soil through friction of soil on pipe. The direction of thrust to be resisted at an elbow is half of the offset angle of the elbow. Without external thrust restraints, welded joints at the special sections must be able to resist the full longitudinal thrust. Welded joints are usually able to resist full thrust. The thrust due to special sections is:

$$2Q = \pi D^2 (P + \gamma_w v^2/g) \sin (\theta/2) \quad (29)$$

Example

A 51-inch (1,275 mm) water pipe with internal pressure,

$P = 120$ psi (827 kPa), flows at about $v = 15$ ft per second (4.57 m/second).

What is the longitudinal thrust caused by a 90° elbow ($\theta = 90^\circ$)?

θ is the angle offset of the elbow.

Thrust, $Q = Q_p + Q_i$, where, due to pressure, $2Q_p = P\pi D^2 \sin (\theta/2)$.

Solving, $Q_p = 347$ kips. Due to change in direction of flow (impulse),

$2Q_i = (\pi D^2 v^2 \gamma_w/g) \sin (\theta/2)$, where g is gravity. $Q_i = 8.7$ kips.

Adding $Q_p + Q_i = 356$ kips (1.58 MN). The thrust due to impulse, Q_i , accounts for only 2.4% of the total thrust. Impulse thrust is usually negligible.

2. Longitudinal Contraction

Longitudinal stresses are caused by temperature change and internal pressure *if the ends of the pipe are fixed*; i.e., if the pipe cannot shorten in length. Longitudinal tension stresses are:

$E\alpha(\Delta T)$, caused by temperature decrease; and $\nu PD/2t$, caused by internal pressure increase (Poisson effect). Longitudinal tension stress, σ_z , in a straight, *fixed-ended* pipe, due to temperature decrease and internal pressure increase, is:

$$\sigma_z = E\alpha(\Delta T) + \nu PD/2t \quad (30)$$

where

E	=	modulus of elasticity of steel = 30,000,000 psi (207 GPa)
α	=	coefficient of thermal expansion of steel $6.5(10^{-6})/^{\circ}\text{F}$
ΔT	=	decrease in temperature in degrees Fahrenheit, $^{\circ}\text{F}$ [$^{\circ}\text{F} = 1.8(^{\circ}\text{C}) + 32$ where $^{\circ}\text{C}$ is in degrees Celsius.]
ν	=	Poisson ratio = 0.3 for steel
P	=	internal pressure in the pipe
D	=	diameter
t	=	wall thickness

Example

A straight plain steel pipe, $D = 51$ inches (1,275 mm) and $t = 0.187$ inch (4.75 mm) is fixed-ended and welded up at day-time temperature of 90°F (32°C). When in service with water in the line, temperature is 40°F (4°C) and internal pressure is 150 psi (1.03 Mpa). If $D/t = 274$, what is the longitudinal stress?

From Equation 30, $\sigma_z = 9.75$ ksi + 6.14 ksi. $\sigma_z = 15.9$ ksi (110 Mpa).

This is less than the allowable stress for most pipe grade steel.

Under some circumstances, slip couplings may be needed to eliminate longitudinal stress and to accommodate slight adjustments in direction of the pipeline. It may be prudent to use couplings to eliminate stress across seismic faults, at valve boxes, and at building foundations. These problems are considered under Couplings, page 73.



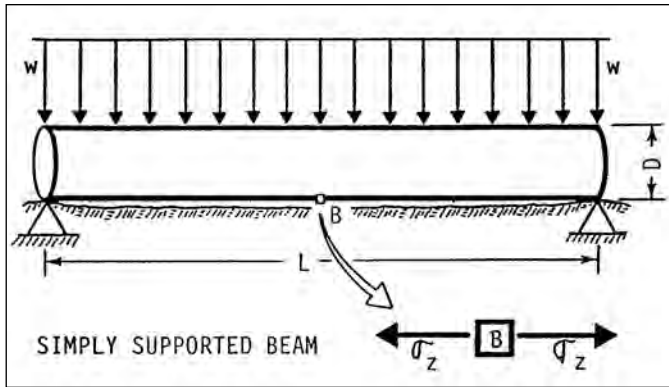

Figure 29. Beam loading for longitudinal stress analysis of a simply supported buried pipe section.

3. Beam Action

To vertically align a pipeline, sections are sometimes supported on mounds at the ends of each pipe. In the case of a gasketed pipe, a worst case is poor, or no, soil under the haunches. See Figure 29. Beam strength is required. For the simply supported span, the maximum longitudinal stress, σ_z occurs at B where, by classical analysis:

$$\sigma_z = (w/2\pi t)(L/D)^2 \quad (31)$$

where

- σ_z = longitudinal stress in the pipe wall
- w = weight of the pipe and contents per unit length
- t = pipe wall thickness
- L = length of the pipe section (stick)
- D = diameter
- P = vertical soil pressure at the top of the pipe

If joints are welded, the beam is fixed-ended. Maximum longitudinal bending stresses are at the ends of the supported sections — not at midspan — and are two-thirds as great as the simply supported beam of Equation 31, for example:

$$\sigma_z = (w/3\pi t)(L/D)^2 \quad (32)$$

The above stresses are analyzed with concentrated reactions. Some soil support is inevitable under the haunches. From tests, the maximum longitudinal stresses are roughly 40% of the stresses calculated for concentrated reactions. Therefore, the idealized Equations 31 and 32 include a safety factor of roughly 2.5.

4. Buried Pipe on Piles

Another case of beam action is a buried pipe on piles in a zone where soil settles. The purpose of the piles is to maintain vertical alignment. When the soil settles, the pipe lifts soil wedges as shown in Figure 22. The wedge soil load is greater than the prismatic PD load.

Example

A welded pipe is to be buried under 2.77 feet (0.84 m) of saturated soil in a tidal zone where soil heaves and settles. To maintain vertical alignment, the pipe is to be positioned on saddles supported by piles spaced at $L = 40$ feet (12.2 m). The unit weight of the saturated soil is 125 pcf (19.6 kN/m³).

Assume that the soil friction angle is 30°. $D = 51$ inches (1,275 mm), $t = 0.187$ inch (4.75 mm).

What is the maximum longitudinal stress, σ_z , when the soil settles and the water table is below the pipe at low tide?

$w_p = 102$ lb/ft = weight of the pipe
 $w_w = 885$ lb/ft = weight of the water in the pipe
 $w_s = 3,448$ lb/ft = weight of the soil wedges
 $w = 4,435$ lb/ft (64.7 kN/m)

From Equation 32, $\sigma_z = 18.6$ ksi (128 kPa). If the spacing of the piles was 60 feet instead of 40 feet, longitudinal stress would be $\sigma_z = 41.8$ ksi (288 kPa). Check concentrated stresses due to the pipe bearing on the pile saddles and limit combined stress to 50% of yield.

Backfilling

To prevent soil settlement and liquefaction, embedment should be placed at a density greater than critical void ratio density. With a margin of safety, 90% Standard Proctor density (ASTM D698 or AASHTO T-99) is usually the specified density. For many installations, gravel or dry coarse sand falls into place at adequate density without additional compaction.



1. Water Compaction

Various methods of settling the soil with water include flushing, ponding and jetting. The density achieved by water compaction is not as great as can be achieved by mechanical compaction; but is often adequate.

- a. Flushing** – Sand can be moved under the pipe by a high-pressure hose. The saturated sand flows into place under the pipe. Good drainage is essential.
- b. Ponding** – If granular soil is placed to the springlines, it can be partially settled by flooding the surface with water and leaving it to allow the soil to settle and shrink in volume. Good drainage is essential. Flotation can be a problem.
- c. Jetting** – With soil up to the springlines, water jets can be used to settle the soil. The jets are high-pressure stingers which can be thrust vertically

into the soil to a depth near the pipe bedding. High-pressure water flushes granular soil laterally under the haunches.

2. Mechanical Compaction

Soil placed in lifts of 8 to 12 inches (0.2 to 0.3 m) on the sides of the pipe can be mechanically compacted. Soil moisture content should be at or near optimum. The pipe should be monitored to prevent vertical elongation caused by heavy compaction at the sides of the pipe. Compactors should not hit the pipe. For efficient compaction techniques, geotechnical engineers can be consulted.

- a. Light compactor zone – Only hand-operated compactors should be permitted within three feet from the pipe and closer than 45° planes tangent to the haunches. Heavy compactors and heavy equipment can operate outside of the light compactor zone.
- b. With only one lift of backfill over the pipe, installers should avoid compacting soil directly above the pipe. With the second lift over the pipe, it is prudent to compact over the sidefill before compacting over the pipe — compacting from the trench walls in toward the center to form a soil arch over the pipe.

3. Controlled Low Strength Material (CLSM)

Controlled low strength material (flowable fill) or grout can be used to form a bedding and to fill voids under the haunches. High strength is not warranted because the bedding is confined. Compressive strength of 40 psi (280 kPa) is generally adequate. A slump of 10 inches is about right for flowability. See Flowable Fill, page 62.

Compound Stress Analysis

Performance limit is yield strength σ_f . The standard test is a tensile test of a circular rod. For steel, stress is critical on a 45° plane where shearing stress is maximum. Shearing strength is, $\tau_f = \sigma_f / 2$.

For compound stress analysis, the free-body-diagram is an infinitesimal cube subjected to three principal stresses. Shearing stresses are zero if the cube is oriented to the principal stresses. See Figure 30.

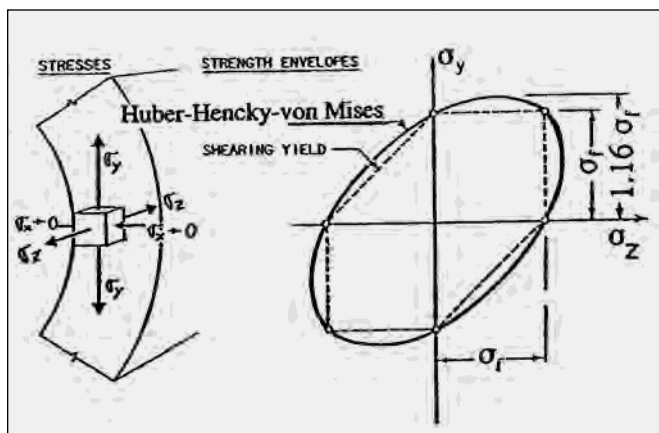

Figure 30. Strength envelopes at elastic limit, σ_f , by compound stress analyses when $\sigma_x = 0$.

In steel pressure pipe, the minimum principal stress, σ_x , is usually internal pressure which is of opposite sign from the maximum principal stress, hoop stress, σ_y . Internal pressure, σ_x , is usually small enough to be neglected. The strength envelopes of Figure 30 are based on $\sigma_x = 0$. If values for σ_y and σ_z are known, the corresponding strength can be found from Figure 30. Based on shearing strength theory, the strength envelope is shown dotted. Tests show that the strength envelope for steel is more nearly an ellipse as shown in solid line. Strain-energy analyses produce elliptical strength envelopes.

1. Huber-Hencky-von Mises Equation

One elastic strain-energy model for steel is the Huber-Hencky-von Mises Equation which subtracts out that part of strain energy that only results in volume change. Assuming that $\sigma_x = 0$, the equation for the strength envelope is:

$$\sigma_y^2 + \sigma_z^2 - \sigma_y\sigma_z = \sigma_f^2 \quad (33)$$

a plot of which is the ellipse shown in Figure 30. The stresses are all principal stresses. For most buried pipe, the Huber-Hencky-von Mises analysis is not justified. Equation 33 is based on elastic analysis. But elastic limit (yield stress) is not necessarily the performance limit for buried steel pipe. If a section of pipeline is capped such that $\sigma_z = \sigma_y/2$ (both σ_z and σ_y are in tension), from Equation 33, the hoop strength is $\sigma_y = 1.155\sigma_f$. The increase in hoop strength is only 15.5%. It is conservative to design by uniaxial stress analysis; i.e., critical stress is $\sigma_y = \sigma_f$. If, perchance, longitudinal stress, σ_z , is of opposite sign from the hoop stress, σ_y , Equation 33 should be applied. The strength envelope is shown in the upper left and lower right quadrants of Figure 30. The probability that σ_z and σ_y are of opposite signs is remote.

2. Stresses at Mitred Bends

Figure 31 shows a mitred bend (exaggerated). Due to pressure, P , inside the pipe, force, Q on the bend is $Q = 2P\pi r^2 \sin\theta$. The impulse force due to change in direction of flow is neglected because it is usually relatively small. With no external thrust restraints, Q must be resisted by the pipe wall for which shear, V , and thrust T , are:



$$V = P\pi r^2 \sin\theta \cos\theta \quad (34)$$

$$T = P\pi r^2 \sin^2\theta \quad (35)$$

If the maximum offset angle, 2θ , for a mitred bend is 22.5° , then $V = 0.6Pr^2$, and $T = 0.12 Pr^2$. Shear, V , is easily resisted by the pipe wall, and is reduced by soil support. Thrust, T , is small enough to be neglected. This is an analysis of the pressure effect. The dynamic effect (impulse) is negligible.

If pipe alignment is held (by soil embedment), and if cut BB' is moved up to the seam so that it passes through A' , stress distribution is a triangle rather than a trapezoid. The maximum longitudinal stress (at A') is twice the average longitudinal stress in the pipe. Because this is about the same as hoop stress in the pipe, yield stress is not exceeded. In fact, allowable stress is only half of yield stress, so a safety factor of two is still in effect.

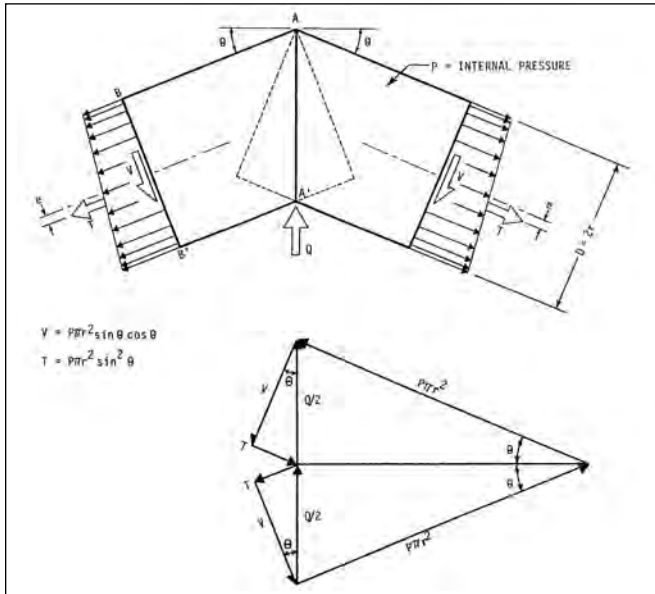

Figure 31. Free-body diagram of mitred bend in a pipe (top), and the free-vector diagram of forces acting on it (bottom) due to internal pressure, P . Impulse forces are neglected.

Hoop strength is lost at the mitred seam because of the skewed cuts. The hoop stress triangles to be resisted are shown in Figure 32. The seam must resist hoop stresses from both sides of the seam, so

$$2w = 2 Pr \sin \alpha \cos \theta.$$

Simplified,

$$w = Pr \sin \alpha \cos \theta \tag{36}$$

where

w = force on the welded seam per unit length of seam

P = internal pressure

r = radius of circular pipe

θ = offset angle (mitre angle)

α = the angle (shown in Figure 32) formed between the centerline of the mitred elbow and any specified location on the weld where the force w is applied.

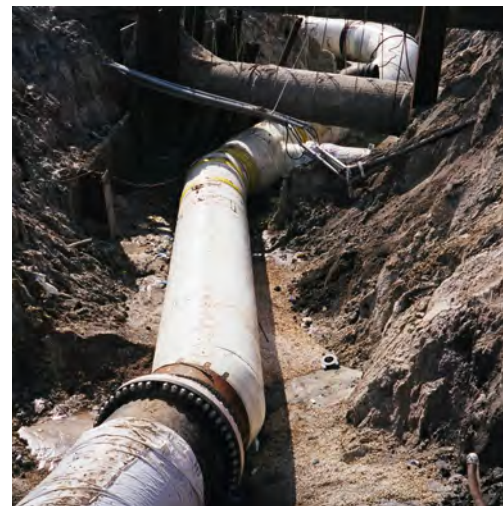

In general, there is no need to increase the wall thickness of the mitred bends. Mitres are usually shop-fabricated from pipe of the same wall thickness as the pipeline. Typically, θ is a maximum of 22.5° and a minimum radius of the bend is equal to 2.5 times the pipe diameter.

Figure 32. Force, w , on the mitre seam per unit length of circumference, due to internal pressure, P , where hoops are cut.

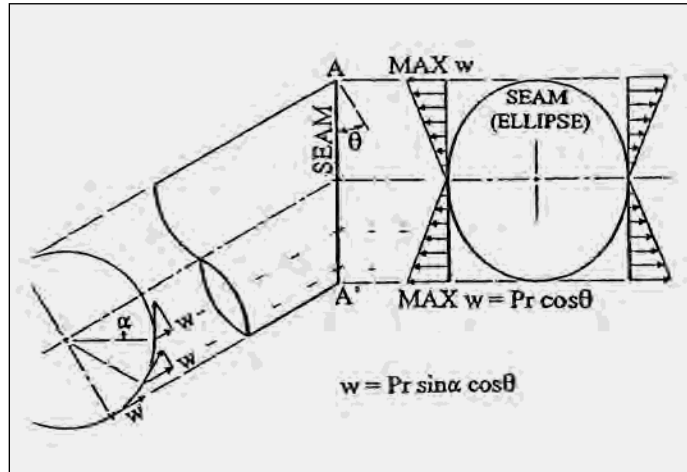

Strength of Field-Welded Joints

If the weld is a full-penetration butt (groove) weld, Figure 33 (top), the weld's longitudinal strength is no less than the longitudinal strength of the pipe. The wall yields before the weld yields. For design, the longitudinal strength of a butt weld is assumed to be equal to pipe strength — weld efficiency is 100%. With few exceptions, longitudinal stress is less than half the hoop stress.

Because the longitudinal stress is less than half the hoop stress, single lap welds are adequate, and are typically used. If the longitudinal stress exceeds 70% of the allowable stress, use double lap welds (both inside and outside) to increase the strength of the joint to that of the pipe wall.

Figure 33. Butt welds (top) and lap welds, showing force, T , per unit length of circumference. Weld efficiency is the ratio of longitudinal weld strength to yield strength of the pipe wall.

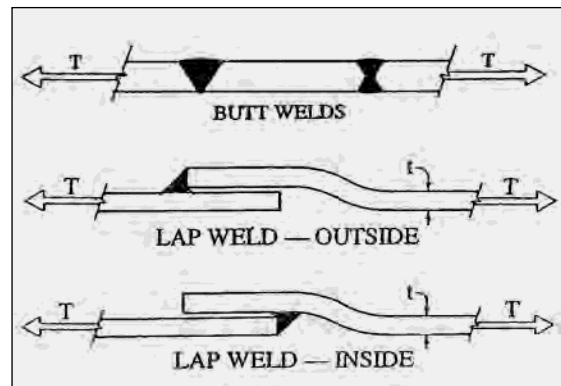
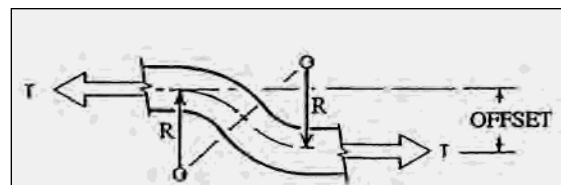

Figure 34. Transition offset in the pipe wall from pipe to bell at critical radius, R .



A question is sometimes raised concerning bending moment in the weld caused by the offset shown in Figure 34. The bending moment is small because the force on a lap weld is basically a shearing force, T , as the spigot pipe tends to slip out of the bell sleeve. The curvature of the cylinders resists bending moment. If tests for weld strength are required, full pipe sections — not just coupons — are recommended. Width of the annular space between bell and spigot should be controlled to a maximum of $\frac{1}{8}$ " (3.2 mm).



Figure 34 shows the transition of pipe wall from pipe to bell. If fracture occurs, it may be in the transition. The radius of transition, R , should be great enough that the pipe wall is not cracked when it is expanded into a bell. In general, cracks do not form if strain is less than 25%. From fundamentals of mechanics, $1/R = 2\epsilon/t$. Critical radius is:

$$R = t/2\epsilon \quad (37)$$

where

R = longitudinal transition radius of the neutral surface of the pipe wall

t = wall thickness

ϵ = strain in the wall surface

If allowable strain is, conservatively, 20%, $R = 2.5t$. With a safety factor of two, the radius of transition should be at least $R = 5t$. AWWA standards require a conservative $R = 15t$ minimum.

The Effect of Mortar Linings and Coatings on Ring Stiffness



Disregarding bond between mortar and steel, the effective ring stiffness of the lined and/or coated wall section is the sum of the separate ring stiffnesses, of steel, lining and coating. Ring stiffness is $\Sigma EI/D^3$. The contribution of mortar is significant as shown in the following example.

Example

What is the ring stiffness for a pipe with cement mortar lining and coating if the inside diameter of the lining is 36 inches (900 mm)? See Figure 35.

Data are as follows:

t = wall thickness of each layer

D = diameter to neutral surface of each layer

I = $t^3/12$ for a unit slice of each layer

E = 30,000,000 psi (207 GPa) for steel

E_m = 4,000,000 psi (27.6 GPa) for mortar

$$EI/D^3 = E/12(D/t)^3$$

Coating	$t = 0.75$	$D = 38.100$	$EI/D^3 = 2.543 \text{ psi} = 69.5\%$
Steel	$t = 0.175$	$D = 37.175$	$EI/D^3 = 0.261 \text{ psi} = 7.1\%$
Lining	$t = 0.50$	$D = 36.500$	$EI/D^3 = 0.857 \text{ psi} = 23.4\%$
			$\Sigma EI/D^3 = 3.661 \text{ psi} = 100\%$

Discounting bond, ring stiffness is $\Sigma EI/D^3 = 3.66 \text{ psi}$. It is noteworthy that mortar provides most of the ring stiffness. This is conservative because if the bond is included, the stiffness would be approximately five times greater.

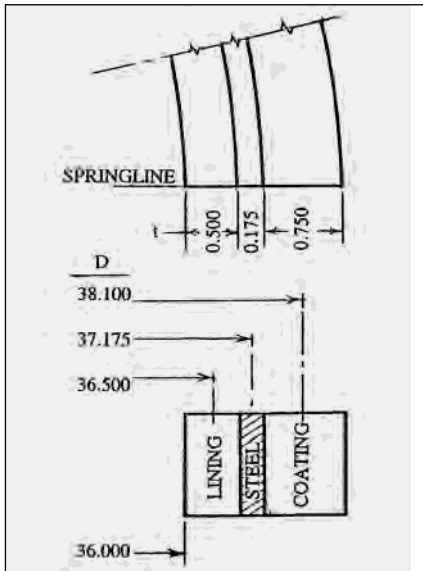

Figure 35. Example of unit slice of mortar lined and coated pipe, showing dimensions.

Example

If decrease in the inside vertical diameter is found to be $\Delta = 1.00$ inch, what are the maximum stresses in the example above? Bond is disregarded. Ring deflection is $d = \Delta/D$ for each layer considered separately. Ring deflection is assumed to be elliptical.

σ = stress at springline due to ring deflection, $d = \Delta/D$

E_s = 30(10⁶) psi (207 GPa) for steel

E_m = 4(10⁶) psi (27.6 GPa) for mortar

I = moment of inertia of cross section (I cancels out)

M = bending moment at springline

r_x = minimum radius as measured for an ellipse

$r = D/2 =$ radius of circular ring

$M/EI = 1/r_x - 1/r$, where $M = 2\sigma l/t$, and $r_x/r = (1-d)^2/(1+d)$ for ellipse
 $(\sigma/E)(D/t) = 3d(1-2d) = 3d/(1-d)$, or approximately $3d$

Layer	D (in)	t (in)	D/t	d (%)	Stress, $\sigma = 3Ed/(D/t)$
coating	38.100	0.75	50.80	2.62	6.2 ksi (43 MPa)
steel	37.175	0.175	212.43	2.69	11.4 ksi (79 MPa)
lining	36.500	0.500	73.00	2.74	4.5 ksi (31 MPa)

Stress in the steel is higher than stress in the mortar because the stiffness of steel, E , is higher. But stress in the steel is well below yield. The mortar is stressed beyond tensile strength. Small cracks are to be anticipated.

In this example, it is assumed that there is no bond between mortar and steel. Each layer supplies its own ring stiffness.

The no-bond ring stiffness is $\Sigma EI/D^3 = 3.66$ psi (25.3 kPa).

In fact, there is bond. If bond could be assured, the cross section would be analyzed as a composite. The wall cross section would be transformed into an equivalent cross section in mortar (or steel).

The “bond” stiffness would be $EI/D^3 = 19.6$ psi with a safety factor of 5 compared to the “no-bond” ring stiffness of 3.7. Of course, when the mortar cracks, it partially loses tensile strength and stiffness. Design by “no-bond” analysis is recommended.

Plastic Analysis

Figure 36 is a section of plain pipe wall subjected to a bending moment caused by ring deflection, showing the elastic stress distribution on the right and the plastic stress distribution on the left. Because yield stress, σ_y , is the same for both analyses, the moment can be calculated for each stress distribution. It is easily demonstrated that $M_p = 3M_e/2$.

Plastic analysis is the more reasonable performance limit for plain pipe because it represents the bending moment at plastic hinging – the maximum bending moment that the wall can resist. In fact, the “ductile hinge” of steel resists even more bending moment than the plastic hinge. Elastic analysis would add an additional safety factor of 3/2.

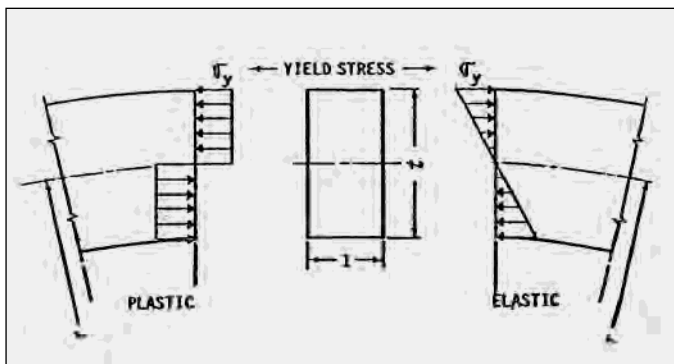

Figure 36. Unit slice of plain pipe wall. If bending causes yield stress, σ_y , at the wall surface, stress distributions are elastic stress shown on the right and plastic stress shown on the left. $M_p = \sigma_y t^2/4$ and $M_e = \sigma_y t^2/6$.

Measurement of Radius of Curvature

The assumption of elliptical ring deflection is not precise. Critical deformation is the large radius of curvature at flattened areas in pipe. Small dings and dents are not an issue because longitudinal beam action bridges over them. An approximate analysis of flattened areas that extend more than one diameter along the pipe is the elliptical ring deflection analysis, except that measured values of maximum and minimum radii are substituted for the elliptical r_y and r_x . Radius of curvature can be measured by laying a short straight edge of known length tangent to the pipe on the outside or a chord inside. See Figure 37. Offset, e , is measured from pipe to the middle of the straight edge.



If L is the length of the straight edge, radius of curvature is $r = L^2/8e + e/2$ plus or minus a $t/2$ correction to the neutral surface. Accuracy is adequate for measured radius:

$$r = L^2/8e \quad (38)$$

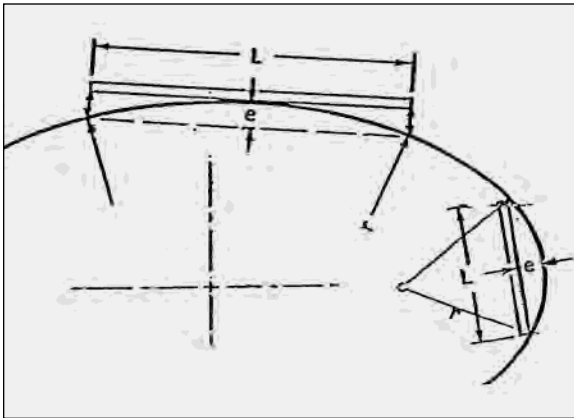

Figure 37. Technique for finding the radius of curvature, r , of a pipe ring by measuring the offset, e , from a cord of known length, L , to the pipe surface.

Crack Width Analysis

Small cracks in mortar linings and coatings are inevitable, but are not critical. If cracks are too wide, it may be possible for enough water and air to reach the steel to cause corrosion. Under some circumstances, cracks wider than $1/16$ inch (1.6 mm) are filled or patched. For longitudinal cracks, this may not be necessary if the pipe re-rounds when pressurized. The question is often asked: should crack width be controlled by limiting allowable ring deflection? The widest cracks in the lining due to ring deflection are at the invert or crown. In general, the ring has to reverse curvature to open a crack wider than $1/16$ inch in the lining. The widest cracks in mortar coating are at springlines, and can be estimated from inside the pipe by measuring the minimum radius of curvature, r_x . Figure 38 shows the maximum possible width, w , of a single crack in the coating thickness, t , from the equation:

$$w/2t = 1/r_x - 1/r \quad (39)$$

If ring deflection is less than 5%, crack widths caused by elliptical ring deflection are less than $1/16$ inch. When the pipe is pressurized and re-rounded, deflection cracks in the mortar close. However, small cracks remain due to expansion of the steel pipe when it is subjected to internal pressure. These are longitudinal hair cracks distributed fairly uniformly around the circumference. But for worst-case analysis it is assumed that cracks open only where initiated by ring deflection during installation at crown and invert in the lining, and at springline in the coating.

The width of these cracks is $w = (\pi/2)D(S/E)$.

For steel, if $S = 21$ ksi, and $E = 30,000$ ksi, then $w = D/910$.

$w = 0.05$ inch (1.34 mm) in a 48-inch diameter pipe

$w = 0.10$ inch (2.7 mm) in a 96-inch diameter pipe

Pressure cracks occur in high-pressure pipes, over 140 psi (970 kPa) internal pressure, for which wall thickness is based on hoop stress. For lower pressure pipes, wall thickness is based on the requirements of fabrication rather than hoop stress. Pressure cracks are usually not an issue.

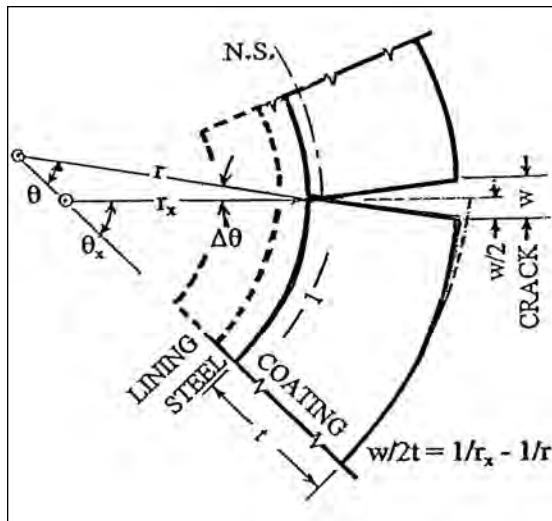

Figure 38. Transverse section of a mortar-lined-and-coated steel pipe wall, showing the maximum possible crack width, w , in the coating at springline caused by a change in radius from circular, r , to measured r_x . Measured r_x can be calculated from the middle ordinate from a short chord of known length to the inside surface of the pipe. Two parallel cracks would each be half as wide as the single crack shown.

Example

A 48-inch (1,200 mm) buried pipe is mortar-lined-and-coated. Thickness of the coating is 0.75 inch (19 mm). Before the buried pipe is pressurized (re-rounded), a reduced radius of curvature inside the pipe at springline was noticed and found to be 16 inches (400 mm). What is the maximum possible crack width in the coating? From Equation 39, $w = 0.03$ inch (0.8 mm).

Flowable Fill

It is a fairly common practice to specify imported soil for bedding and embedment. An alternative might be recycled native soil placed as flowable fill.

Flowable fill is granular soil, usually native, with enough fines that it can be mixed into a slurry. Flowable fill reduces or eliminates problems such as uneven

bedding, ring deflection, non-uniform embedment support, and voids under the haunches.

Figure 39 is an “impermissible” Class D bedding. The maximum bending moment is at the invert, B, and is $0.15 PD^2$. Ring deflection is $d = 0.015 PD^3/EI$. Figure 40 shows an alternative bedding, “flowable fill” — a full-contact bedding. The bending moment at B is $0.06 PD^2$, which is only 40% of the maximum bending moment in Class D bedding. The ring deflection is $d = 0.002 PD^3/EI$, which is only one-seventh of the ring deflection in Class D bedding. Flowable fill can be used as embedment at the sides, and even over the top of the pipe.

Buried pipe technology lives with a chronic urge to use native soil as embedment. Some native soils can be recycled as a slurry of soil, water, Portland cement and enough fine particles to make it “flowable.” The objectives of flowable fill are to recycle native soil, and to place bedding and embedment in fewer steps — possibly by means of multi-functional trenchers.

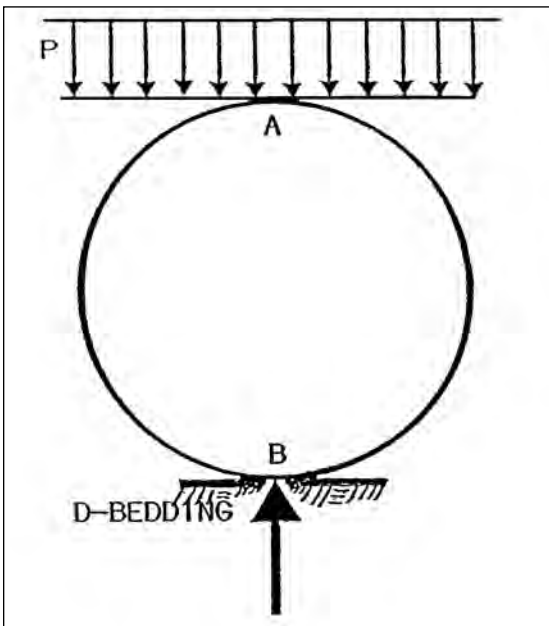

Figure 39. D-Bedding (impermissible bedding). Maximum bending moment, $MB = 0.15PD^2$. Ring deflection is $d = 0.015 PD^3/EI$.

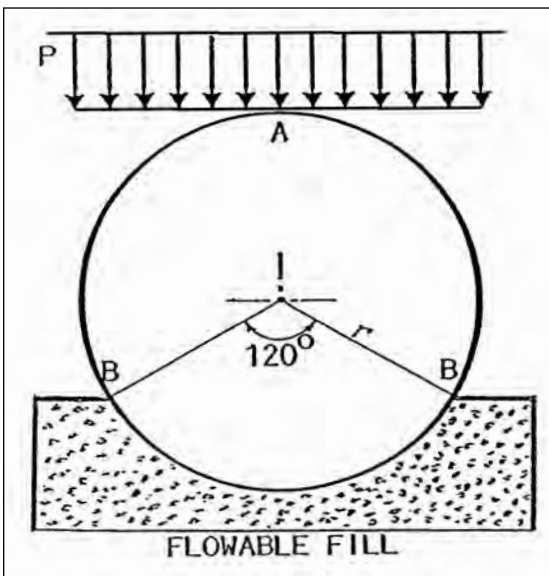

Figure 40. Flowable fill bedding. Critical moment at B is, $Mb = 0.06 PD^2$. Ring deflection is $d = 0.002 PD^3/EI$. Values may vary somewhat in field installations.



Requirements of the Embedment

Flowability

The slurry must be fluid enough to flow under the pipe in full contact with the pipe. To be flowable, fines are required. The fines may include Portland cement or fly ash, but may also include silt and even some clay. A typical slump test of the slurry is 10 inches of slump.

Vertical Compressibility

Ring deflection is roughly equal to vertical compression (vertical strain) of the sidefill soil. If the flowable fill is placed as sidefill, vertical strain must be within limits of ring deflection.

Bearing Capacity

Flowable fill must have enough bearing capacity to support backfill. It must also hold the pipe in shape. High strength is not a primary requirement. Theoretically, because embedment is in compression, it needs no cement. However, some cement is recommended for flowability. Unconfined compression strength should be kept low — no more than 100 psi (689.5 kPa), or it might be argued, compression strength should be no greater than internal pressure in the pipe. Some designers suggest a minimum of 40 psi (275.8 kPa). High strength creates two problems:

1. Embedment cannot be excavated easily in case the pipe must be uncovered.
2. If the embedment cracks due to soil movement (differential subsidence, sidehill slip, etc.) stresses are concentrated on the pipe, and the potential for pipe fracture increases.

Inspection

Large rocks must be screened out of flowable fill. The flowable fill must be fluid enough to flow under the pipe. If used as sidefill, it must not shrink excessively or compress vertically more than allowable ring deflection. It must support the pipe and backfill. A good test is the penetrometer. Bearing capacity and the time of set can be found onsite without delay of installation. Penetrometers are available commercially at a reasonable cost.

Test Results

Field tests show that flowable fill embedments can be of good quality with as little as one sack of cement per cubic yard of native soil with more than 50% silt. This is a much greater percent of fines than the maximum of 10% typically allowed for select embedment.

Conclusions

Designers and constructors should be aware of the alternative of flowable fill beddings and embedments. Some pipeline constructors are experienced and equipped to recycle native soil as flowable fill. Techniques are being “fine-tuned” in all aspects of flowable fill. For example, time of set of the flowable fill can be reduced by additives that induce “quick” set.



Linings and Coatings

Introduction

It is the purpose of this section to assist in the proper selection of protective linings and coatings. The selection of proper protective linings and coatings is critical to ensure long-term protection. The linings and coatings referred to herein are believed to be the most reliable as proven in practice. Some of the following standards apply to both linings and coatings, and some to either:

Exterior and/or Interior Systems

AWWA C-203: Coal-Tar Protective Coatings and Linings for Steel Water Pipelines — Enamel and Tape-Hot Applied

This standard describes the material and application requirements for shop-applied coal-tar protective coatings and linings for steel water pipelines intended for use under normal conditions when the temperature of the water in the pipe will not exceed 90°F (32°C). The standard covers coal-tar enamel applied to the interior and exterior of pipe, special sections, connections and fittings, and hot-applied coal-tar tape applied to the exterior of special sections, connections and fittings.

Coal-tar enamel is applied over a coal-tar or synthetic primer. External coal-tar enamel coatings use bonded felt and fibrous glass mat to reinforce and shield the coal-tar enamel. The applied external coating is usually finished with either a coat of whitewash or a single wrap of Kraft paper.

Internally, the coal-tar enamel is used without reinforcement or shielding. The hot enamel is spun into the pipe, and provides a smooth internal lining, which has low hydraulic frictional resistance.

The standard provides a rigid, yet reasonable, manufacturer's guide for the production of the coating, and calls for tests of material and its behavior – which assure the purchaser that the product has the desired qualities. The document also furnishes directions for effective application of the coating.

AWWA C-205: Cement-Mortar Protective Lining and Coating for Steel Water Pipe — 4-Inch and Larger Shop-Applied

C-205 describes the material and application requirements to provide protective linings and coatings for steel water pipe by shop application of cement mortar.

Cement mortar is composed of Portland cement, sand and water well mixed and of the proper consistency to obtain a dense, homogenous lining or coating. Internally, the cement mortar is centrifugally compacted to remove excess water and produce a smooth uniform surface. Cement mortar linings are limited to services with flow velocity of 15 feet/second (4.57 meters/second) or less. Externally, the coating is a reinforced cement mortar pneumatically or mechanically applied to the pipe surface. Reinforcement consists of spiral wire, wire fabric or ribbon mesh. The standard provides a complete guide for application and curing of the mortar lining and mortar coating.

AWWA C-210: Standard for Liquid Epoxy Coating Systems for the Interior and Exterior of Steel Water Pipelines

AWWA C-210 describes a liquid epoxy coating system, suitable for water service, which will provide corrosion protection to the interior and exterior of steel water pipe, fittings and special sections installed underground or underwater. Unless specified otherwise by the purchaser, the coating and lining systems may consist of any of the following three types:

1. A two-part, chemically cured epoxy primer and one or more coats of different two-part, chemically cured epoxy topcoat
2. Two or more coats of the same two-part chemically cured epoxy coating, in which case, the first coat shall be considered as the prime coat, or
3. A single coat of a two-part chemically cured epoxy coating

These coatings are suitable when used for corrosion prevention in water service systems at temperatures up to 140°F (60°C). The products are applied by spray application, preferably airless.

The liquid epoxy system described in the standard differs from the customary product commercially available in that it has a very high flexibility, elongation and impact resistance. Any liquid offered for water utility purposes must meet the requirements of AWWA C-210.

AWWA C-222: Polyurethane Coatings for the Interior and Exterior of Steel Water Pipe and Fittings

These coatings are used for steel water pipe, special sections, welded joints, connections or fittings for steel water pipelines installed underground or underwater operating under normal conditions.

Unless otherwise specified by the purchaser, the lining and coating systems shall consist of an ASTM D16 Type V thermoset, aromatic polyurethane plastic polymer that is the reaction product of diphenylmethane diisocyanate (MDI) resin



Applying a heat-shrinkable coating.

and polyol resin, or polyamine resin or a mixture of polyol and polyamine resins. Typically, these systems are solvent-free or almost solvent-free (less than 10% solvent by volume). They are fast setting (cure to handle is less than 30 minutes) and are applied in one coat directly to the steel using heated, plural-component, airless spray equipment. However, there is a wide variety of polyurethane technologies available on the market that contain solvents or are slower setting that also meet the requirements of this standard. The minimum dry film thicknesses are 20 mils for pipe interior and 25 mils for pipe exterior. The system offers good abrasion resistance, one coat unlimited thickness build, low levels of volatile organic compounds (VOCs) and high corrosion and chemical resistance.

Exterior Systems

AWWA C-209: Cold-Applied Tape Coatings for Special Sections, Connections and Fittings for Steel Water Pipelines

AWWA C-209 has been issued to incorporate the use of cold primer and cold-applied tape on the exterior of special sections, connections and fittings for steel water pipelines installed underground in any soil under normal or average conditions. Tapes with both polyvinyl chloride and polyethylene backing are listed in AWWA C209. The thickness of the tapes varies; however, all tapes may be sufficiently overlapped to meet changing performance requirements. Cold-applied tapes provide ease of application without the use of special equipment, and can

be applied over a broad range of application temperatures. If severe construction or soil conditions exist where mechanical damage may occur, a suitable over-wrap of an extra thickness may be required.

AWWA C-214: Tape Coating Systems for the Exterior of Steel Water Pipelines

This standard covers the materials, systems and application requirements for prefabricated cold-applied tapes for the exterior of all diameters of steel water pipe placed by mechanical means. For normal construction conditions, prefabricated cold-applied tapes are a three-layer system consisting of:

- a. A primer
- b. Corrosion preventive tape (inner layer) and
- c. Mechanical protective tape (outer layer). This standard covers application at coating plants.

AWWA C-216: Heat-Shrinkable Cross-Linked Polyolefin Coatings for the Exterior of Special Sections, Connections and Fittings for Steel Water Pipelines

This standard describes the material, application and the field-procedure requirements for heat-shrinkable cross-linked polyolefin coatings. The application of protective exterior coatings to special sections, connections and fittings to be used in underground and underwater steel water pipelines is also included.

Heat-shrinkable coatings may be field- or shop-applied as provided in this standard. This standard describes only heat-shrinkable coatings that consist of polyolefin backing that has been cross-linked by either electron beam or chemical means and coated with an adhesive. There are three types of products: tubular sleeves, wrap-around type and tape type. The coatings are applied to a clean surface and then heated to cause shrinkage. This will allow the coating to conform and adhere to the surface of the pipe or fittings.

AWWA C-218: Coating the Exterior of Aboveground Steel / Water Pipelines and Fittings

This standard covers nine, thin-film coating systems designed to protect the exterior surfaces of steel pipelines and the associated fittings used by the water supply industry in aboveground locations. The coating systems described may not perform or cost the same, but they are presented so that the appropriate coating system can be selected for the site-specific project requirements.

Interior Systems

AWWA C-602: Cement-Mortar Lining of Water Pipelines — 4-Inch and Larger — in Place

This standard describes the materials and application processes for the cement-mortar lining of pipelines in place, including both newly installed pipes and older pipelines. Detailed procedures are included for surface preparation and application, surface finishing and curing of the cement mortar. Cement mortar linings are

limited to services with flow velocity of 15 feet/second (4.57 meters/second) or less.

Coating Application

This manual does not furnish details on methods of coating and paint applications, but the importance of obtaining proper application cannot be overemphasized. Effective results cannot be secured with any coating material unless adequate care is taken in preparing the surfaces for coating, in applying the coating and in handling the pipe after coating. AWWA standards provide the requirements for obtaining good coating work. The coating manufacturer, the applicator and the engineer should all cooperate to see that the work is of the prescribed quality. Many excellent sources of information have been published dealing with the protection of steel pipe, the pitfalls of coating work and the means of avoiding these problems.



Effective results in coating depend upon careful surface preparation, application and handling of the pipe.



Joints

Steel pipe lengths can be joined together in the field by many different configurations to effect rigid or flexible connections. Discussion of the most commonly utilized joints includes:

Bell and spigot joints with rubber gaskets

are used for pipe diameters up to 72 inches (1.82 meters) and wall thickness through $\frac{3}{8}$ -inch (9.52 mm) for working pressures up to 250 psi (1,723.7 kPa). This type of joint allows for some angular deflection (flexibility) at the joint and is the least costly to install. When using this type of joint, supplemental restraint or anchoring must be considered at all points of longitudinal thrust. The AWWA C200 Standard covers requirements for this type of joint. Common types are shown in Figure 43.

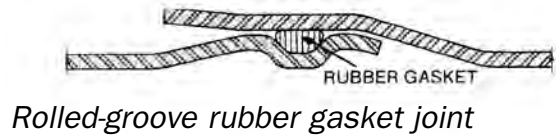

Rolled-groove rubber gasket joint

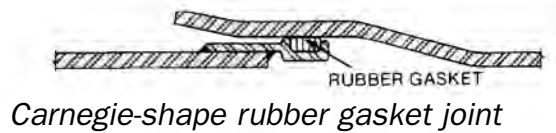

Carnegie-shape rubber gasket joint

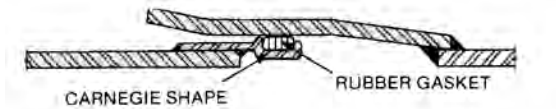

Carnegie-shape rubber gasket joint with weld-on bell ring

Figure 43.

Welded lap joints

are used for all pipe diameters for working pressures up to 400

psi (2,757.9 kPa), and sometimes higher. This type of joint allows for some angular deflection at the joint during construction and the joint can be assembled very quickly in the field, resulting in a considerable savings over butt-welded joints. The lap-welded joint may be welded on the outside only, or for sizes that can be entered safely, on the inside only. In certain special conditions, it may be desirable to weld on both the inside and outside, and to perform an air

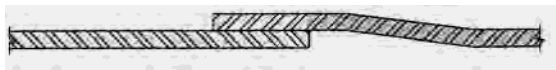

Welded Lap Joint

Figure 44.

test on the joint. AWWA C200 covers requirements for this type of joint and AWWA C206 covers welding of this type of joint in the field. Figure 44 shows a cross section.



Welded butt joints are suggested for working pressures over 400 psi (2,757.9 kPa). This type of joint does not allow angular deflection at the joint except by miter cut of the pipe ends. Deflections of up to 5 degrees can be taken by mitering one end of a pipe and deflections of up to 10 degrees can be taken by equal miter cuts of both pipe ends. Fit-up of this type of joint is more difficult and is usually accomplished by the use of line-up clamps or a back-up bar welded to one end of the pipe. A full-penetration groove weld is required for this joint. The AWWA C200 Standard addresses requirements for this type of joint and AWWA C206 covers necessities for field welding. Below are shown several details for this joint from ANSI/AWS D1.1.

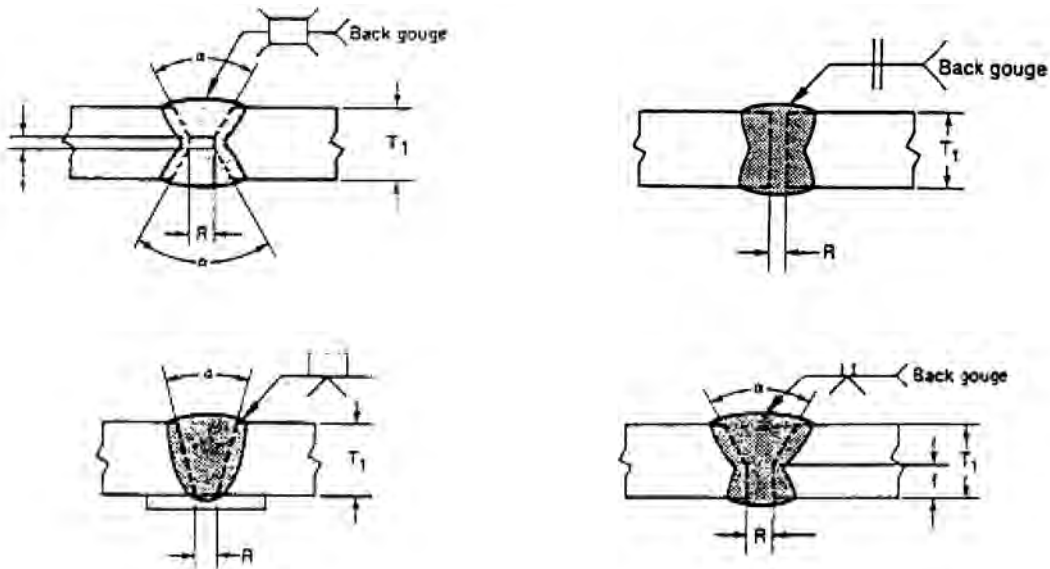

Figure 45. Prequalified complete joint penetration groove welded joints

Butt-strap joints are used for closures or temperature stress-control joints on butt-welded lines. The butt strap may be shipped loose in one or two sections requiring a longitudinal field weld or it may be shop-welded to the end of one pipe. In certain conditions, it should be welded inside and outside, in which case, tapped holes for an air test shown in AWWA C206 Standard can be provided.

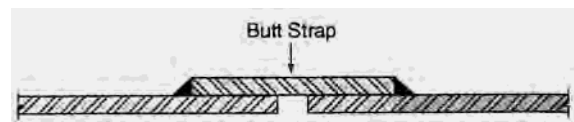

Figure 46. Butt strap joint

Mechanical couplings are used on pipelines of all diameters and pressures. Very complete technical data have been published with the AWWA C219 Standard covering requirements for sleeve-type couplings. Mechanical couplings provide tightness and strength with flexibility. They relieve expansion

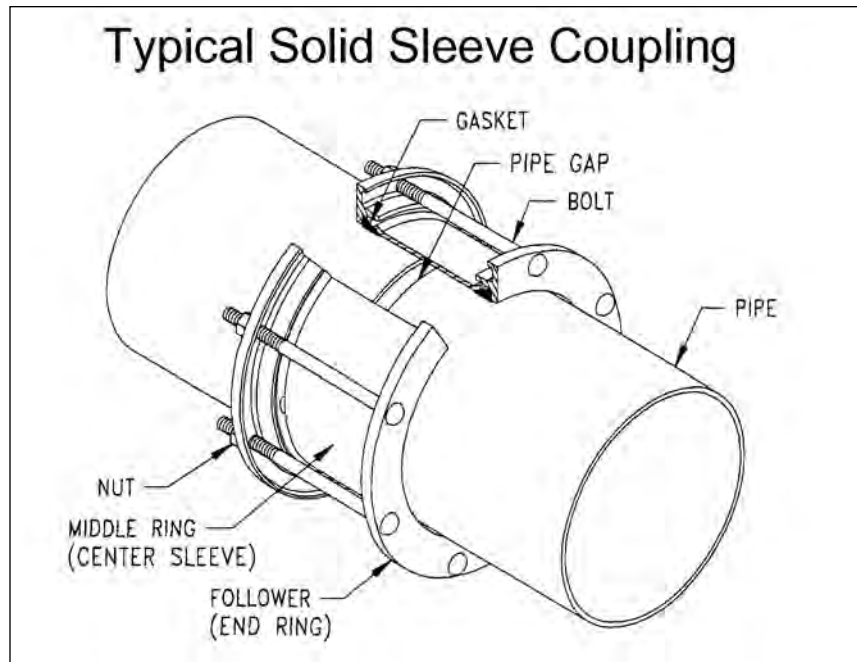

Figure 47. Mechanical joint

and contraction forces in a pipeline and provide sufficient flexibility so that pipe may be laid on long radius curves and grades without the use of specials. Rubber gaskets are firmly held between the coupling parts and the pipe, and they join the lengths securely against any internal pressure conditions, including vacuum. The completely enclosed rubber gaskets are protected from damage and decay. These joints have been used successfully since 1891.

Acceptable axial movement in flexible, solid-sleeve couplings is $\frac{3}{8}$ -inch (9.52 mm), which is derived from the shear displacement of the rubber gaskets rather than from sliding of the gaskets on the mating surface of the pipe. If greater displacement is needed, true expansion joints should be provided rather than mechanical couplings. Unrestrained mechanical couplings transmit only minor tension or shear stresses across pipe joints, and they will not permit differential settlement at the joints when used alone. However, flexibility is possible when used in conjunction with another adjacent flexible joint.

Split-sleeve couplings are often utilized as an alternative to solid-sleeve couplings. Split-sleeve couplings can be designed to allow for greater pipe out-of-roundness (barrel deflection), complete joint restraint, expansion and contraction greater than $\frac{3}{8}$ -inch (9.52 mm) and many other common (or uncommon) field conditions. A typical split-sleeve coupling is shown in Figure 48. The materials

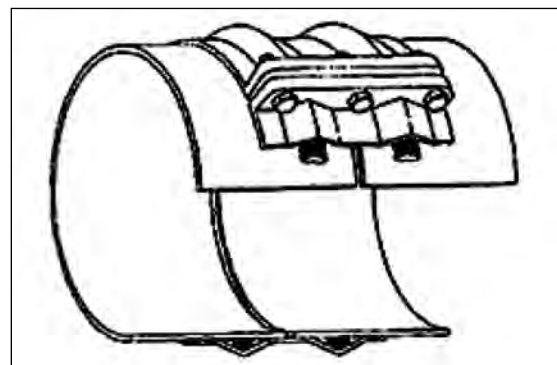

Figure 48. Typical Split Sleeve Coupling

quality and performance of split-sleeve type couplings must conform to the requirements of AWWA C227.



Flanged joints are commonly used for connecting to valves or other appurtenances. Flanged joints are not generally used for field joints on large diameter pipe because of their high cost and lack of flexibility. There are advantages, however, for special connections, such as bridge crossings, long spans or for other rigid joint needs. Standard flanges with pressure ratings

for cold water service are governed by the requirements detailed in AWWA C207 and are shown below.

Class B, 86 psi (592.9 kPa)

Class D, 175 psi (1206.6 kPa) for 4-inch to 12-inch and
150 psi (1,034.2 kPa) for over 12-inch

Class E, 275 psi (1,896.1 kPa)

Class F, 300 psi (2,068.4 kPa)

Appendix A

Partial Tabulation of Steel Water Pipe Installations Prior to 1916

YEAR INSTALLED	LOCATION	DIAMETER INCHES	FOOTAGE	THICKNESS
1858	Railroad Flat, Cal.	22"-11"	—	16 Ga.
1860	New York, N. Y.	90"	1,000'	1/2"
1863	San Francisco, Cal.	37"-30"	27,280'	1/4"
1870	San Francisco, Cal.	30"	42,240'	12 Ga.
1870	Magalia, Cal.	30"	—	10 Ga.
1870	Pioche, Nev.	5"	8,000'	14 Ga.
1871	San Francisco, Cal.	22"	2,105'	9 Ga.
1873	Santa Rosa, Cal.	11"-9"	10,000'	16 Ga.
1873	Virginia City, Nev.	12"	37,000'	5/16"-1/16"
1874	Carson City, Nev.	12"-7"	10,000'	16 Ga.
1874	Pittsburgh, Pa.	50"	2,900'	—
1875	San Francisco, Cal.	22"	2,226'	9 Ga.
1878	Texas Creek, Cal.	17"	4,000'	9-14 Ga.
1880	Los Angeles, Cal.	44"	—	—
1880	San Fernando, Cal.	8"	—	—
1881	Lawrence, Mass.	77"	—	3/8"
1882	San Francisco, Cal.	22"	6,800'	1/8"-3/16"
1882	San Francisco, Cal.	30"	3,480'	1/4"
1882	Longmont, Colo.	6"	23,000'	—
1883	Fort Collins, Colo.	10"	18,000'	3/16"
1884	San Francisco, Cal.	33"	2,409'	1/4"
1885	San Francisco, Cal.	30"	13,409'	1/4"
1885	San Francisco, Cal.	44"	90,000'	6 & 7 Ga.
1887	Riverside, Cal.	24"	45,000'	—
1887	Pasadena, Cal.	6"	—	—
1888	San Francisco, Cal.	22"	12,000'	—
1888	Pasadena, Cal.	22"	18,000'	14 Ga.
1888	Sierra Madre, Cal.	4" & 6"	15,000'	16 Ga.
1888	Altadena, Cal.	8"	1,200'	16 Ga.
1888	Redlands, Cal.	24"	2,200'	11 Ga.
1889	Nephi, Utah	3,,	1,500'	16 Ga.
1889	Alhambra, Cal.	7,,	900'	16 Ga.
1889	San Francisco, Cal.	44"	4,878'	3 Ga.
1889	Pasadena, Cal.	13"	6,000'	14 Ga.
1890	San Jose, Cal.	18"	31,000'	12 Ga.
1890	Santa Cruz, Cal.	14"	—	9 Ga.
1890	Detroit, Mich.	72"	—	—
1890	Redlands, Cal.	8"	6,000'	—
1890	Walla Walla, Wash.	20" - 6"	500,000'	7-14 Ga.
1891	Newark, N. J.	48"	111,800'	1/4"-3/8"
1891	Newark, N. J.	36"	23,980'	1/4"
1891	Pittsburgh, Pa.	50"	3,600'	5/8"
1891	The Dalles, Ore.	10"	8,000'	10 Ga.
1891	Pocatello, Ida.	12"	6,000'	16 Ga.
1892	Pasadena, Cal.	8" & 4"	3,000'	—
1892	Butte, Mont.	20"	3,114'	—
1893	Syracuse, N. Y.	54"	6,500'	3/8"
1893	Rochester, N. Y.	36"-38"	136,000'	—
1894	Portland, Ore.	42"-33"	132,000'	5/16"-6 Ga.
1894	Passaic Valley, N. J.	30"	12,300'	5/16"
1895	Pittsburgh, Pa.	60"	49,000'	1/2"
1895	Altadena, Cal.	12"	5,000'	14 Ga.
1895	Pasadena, Cal.	8"	1,200'	14 Ga.
1895	Vancouver, B. C.	22" & 16"	52,000'	12 Ga.
1895	San Francisco, Cal.	30"	4,090'	1/4"
1895	Kearney, N. J.	42"	8,800'	—
1896	Minneapolis, Minn.	48"	31,680'	—
1896	Newark, N. J.	48" & 42"	111,600'	1/4"
1896	Passaic Valley, N. J.	42"	8,700'	1/4"-3/8"
1896	New Bedford, Mass.	48"	42,000'	5/16"
1896	Bayonne, N. J.	30"	44,000'	—
1896	New Westminster, B. C.	14"	70,000'	—
1896	New York, N. Y.	72"	—	—
1897	Minneapolis, Minn.	50"	16,605'	7/16"
1897	Ogden, Utah	72"	4,600'	—
1897	Patterson, N. J.	42"	18,600'	5/16"
1897	Jersey City, N. J.	48"	—	1/2"

YEAR INSTALLED	LOCATION	DIAMETER INCHES	FOOTAGE	THICKNESS
1898	Red Bluff, Cal.	7"	9,000'	14 Ga.
1898	Duluth, Minn.	42"	30,500'	1/4"-1/2"
1898	Allegheny, Pa.	50"	—	—
1898	Albany, N. Y.	48"	8,000'	—
1899	Lawrence, Mass.	108"	154'	3/8"
1899	Passaic Valley, N. J.	51"	44,600'	1/4"-7/16"
1899	Seattle, Wash.	42"	32,000'	1/4" 12 Ga.-1/2"
1899	Kern, Cal.	60"-48"	5,000'	1/4"
1899	Newark, N. J.	51"-48"	17,000'	—
1899	Pittsburgh, Pa.	48"	4,400'	14 Ga.
1900	Redlands, Cal.	4"	3,000'	7 Ga.
1900	San Francisco, Cal.	36"	420'	3/16"
1900	Victor, Colo.	29"	2,500'	—
1900	Marquette, Mich.	42"	600'	—
1900	Butte, Mont.	26"	33,910'	5/16"
1900	Passaic Valley, N. J.	42"	18,600'	3/8"
1901	Pittsburgh, Pa.	42" & 50"	17,000'	1/4"
1901	Atlantic Citv. N. J.	30"	27,000'	—
1901	Seattle, Wash.	42"	61,000'	12 Ga.
1902	Glendora, Cal.	8"	1,120'	14 Ga.
1902	Altadena, Cal.	8"	3,600'	12 Ga.
1902	Montebello, Cal.	20"	—	5/16"
1902	Jersey City, N. J.	72"	93,000'	1/2"
1903	Pittsburgh, Pa.	48"	4,000'	1/4"
1903	Sacramento, Cal.	24"	9,000'	5/16"
1903	Newark, N. J.	60"-48"	40,000'	—
1903	Kansas City, MO.	36"	35,000'	3/8"
1903	Troy, N. Y.	33"	29,000'	14 & 16 Ga.
1903	Chino, Cal.	12"-4"	—	—
1903	Schenectady, N. Y.	36"	23,716'	1/4"-3/8"
1904	Bayonne, N. J.	30"	4,000'	—
1904	Astoria, L. I., N. Y.	60"	15,000'	—
1904	Erie, Pa.	60"	7,920'	—
1904	Toronto, Ont., Canada	72"	6,000'	12 Ga.
1904	Pasadena, Cal.	8"	1,688'	10 Ga.
1904	Red Bluff, Cal.	12"	1,600'	10 Ga.
1904	San Bernardino, Cal.	20"	16,800'	1/2"-3/ 16"
1905	Los Angeles, Cal.	98"-16"	1,108,000'	3/16"
1905	Tillamook, Ore.	10"	24,000'	1/2"
1905	St. Louis, MO.	84"	18,960'	1/4"
1905	Passaic Valley, N. J.	48"-42"	10,000'	3/8"-1/4"
1905	Pittsburgh, Pa.	50" & 30"	28,500'	12 Ga.
1905	Pasadena, Cal.	12"	1,500'	16 Ga.
1905	Altadena, Cal.	8" & 4"	5,000'	—
1905	Lynchburg, Va.	30"	11,500'	—
1905	Wilmington, Del.	48"-43"	20,000'	—
1905	Paterson, N: J.	48"-42"	11,500'	1/4"
1905	Cincinnati, Ohio	84"	1,521'	—
1905	Springfield, Mass.	42"-54"	63,500'	—
1906	Brooklyn, N. Y.	72"	42,300'	—
1906	Philadelphia, Pa.	48"-36"	86,980'	—
1906	Pittsburgh, Pa.	72"-30"	47,000'	3/8"-1/4"
1906	New York, N. Y.	72"	125,000'	7/16"
1906	Honolulu, T. H.	30"	8,000'	—
1907	Corona Heights, Cal.	9"	1,400'	14 Ga.
1907	Pasadena, Cal.	4"	1,235'	16 Ga.
1907	Trinidad, Colo.	15"	184,800'	1/4"
1907	Wilmington, Del.	43"-48"	20,340'	7/16"
1907	Trenton, N. J.	48"	7,000'	5/16"
1907	Lockport, N. Y.	30"	68,640'	1/4"
1907	Pittsburgh, Pa.	36"	3,700'	3/8"
1907	Vancouver, B. C.	30"-22"	65,000'	1/4"-5/16"
1907	St. Louis, MO.	84"	—	—
1907	Montreal, Canada	36"	11,000'	—
1907	Gary, Indiana	36"	4,000'	1/4"
1907	Philadelphia, Pa.	48"-36"	54,000'	—
1908	Canyon, Cal.	36"	1,500'	12 Ga.
1908	Springfield, Mass.	42"	75,000'	1/4"
1908	Missoula, Mont.	6"	20,000'	3/16"
1908	Passaic Valley, N. J.	30"	15,400'	1/4"
1908	Seattle, Wash.	52"-42"	15,000'	—
1908	Michigan City, Ind.	30"	4,000'	—

YEAR INSTALLED	LOCATION	DIAMETER INCHES	FOOTAGE	THICKNESS
1908	Montreal, Canada	36"	25,000'	—
1908	Philadelphia, Pa.	132"	1,590'	—
1909	Beaumont, Cal.	4"	16,000'	16 Ga.
1909	Springfield, Mass.	42"	24,200'	3/8"
1909	Seattle, Wash.	51"	7,660'	3/8"
1909	Portland, Ore.	48"-24"	17,600'	1/4"
1909	Boulder, Colo.	60"	2,640'	1/2"
1909	Erie, Pa.	56"	5,280'	—
1909	Vancouver, B. C.	24"	73,000'	1/4"-3/16"
1909	Brooklyn, N. Y.	72"	83,000'	—
1910	Ensley, Ala.	50"	8,840'	3/8"-5/16"
1910	Pasadena, Cal.	10"-6"	6,000'	14 Ga.
1910	Longmont, Colo.	16"	22,000'	1/4"
1910	New York, N. Y.	48"	16,000'	7/16"
1910	Pittsburgh, Pa.	24"	5,000'	—
1910	Portland, Ore.	52"-44"	128,000'	1/4"
1910	Seattle, Wash.	42"-24"	23,600'	1/4"
1910	New York, N. Y.	36"	11,000'	3/16"
1910	New York, N. Y.	135" & 117"	33,000'	7/16"-3/4"
1910	Montrose, Cal.	36" & 26"	5,200'	—
1910	Pittsburgh, Pa.	24"	5,000'	—
1910	Brooklyn, N. Y.	48"	16,200'	—
1910	Butte, Mont.	42"	1,200'	—
1910	Washington, D. C.	30"	1,220'	—
1910	Paterson, N. J.	42"	2,000'	5/16"
1911	Philadelphia, Pa.	20"	7,700'	—
1911	Glendora, Cal.	9"	5,000'	14 Ga.
1911	Los Angeles, Cal.	120"-90"	49,575'	1/4"-1-1/8"
1911	Pasadena, Cal.	30"	10,297'	10 Ga.
1911	Denver, Colo.	60"	1,111'	3/8"
1911	Portland, Ore.	52" & 44"	130,000'	1/4" & 5/16"
1911	Seattle, Wash.	42"-24"	16,000'	1/4"
1911	Tacoma, Wash.	46"-39"	7,300'	1/4"-1/2"
1911	Montreal, Canada	48"-30"	7,300'	—
1911	Lakeland, Fla.	20"	4,000'	—
1911	Massena, N. Y.	24"	1,323'	—
1911	Marquette, Mich.	66"	8,000'	—
1911	New York, N. Y.	66"	8,510'	—
1912	Chino, Cal.	12"	10,500'	14 Ga.
1912	Los Angeles, Cal.	68"-64"	28,940'	5/16"-3/8"
1912	Pittsburgh, Pa.	30"	5,300'	1/2"
1912	Seattle, Wash.	42"	13,243'	—
1912	Omaha, Neb.	48"	10,550'	—
1912	Ottawa, Canada	42"	2,400'	—
1912	Pittsburgh, Pa.	60"-72"	5,280'	3/8"-1/2"
1912	Union Bav. B. C.	50"	1,326'	—
1912	Rochester, N. Y.	66"	9,200'	—
1912	Winnipeg, Canada	36"	42,500'	—
1912	Akron, Ohio	36"	56,000'	—
1912	Altman, N. Y.	138"-96"	2,000'	—
1912	Belleville, Ohio	168"	2,920'	—
1912	Montclair, N. J.	24"	7,343'	—
1913	Los Angeles, Cal.	72"	—	—
1913	Baltimore, Md.	120"	2,465'	7/16"
1913	Minneapolis, Minn.	48"-54"	27,000'	5/16"-7/16"
1913	Montclair, N. J.	24"	7,325'	1/4"
1913	Utica, N. Y.	36"	1,000'	1/4"
1913	Murray City, Utah	26"-22"	3,882'	7 Ga.
1913	Vancouver, B. C.	36"-26"	46,250'	3/8"-1/4"
1913	Winnipeg, Canada	36"	42,000'	1/4"
1913	Schenectadv. N. Y.	24"	2,420'	1/4"
1913	Kansas City, MO.	48"	1,220'	—
1913	Massena, N. Y.	24"	1,200'	—
1913	Wilkes-Barre, Pa.	36"	1,335'	—
1913	Cleveland, Ohio	48"	2,265'	1/4"
1913	Falls Village, Conn.	108"	826'	5/16"-3/8"
1913	Lock Raven. Md.	120"	2,464'	7/16"
1913	Ocoee, Tenn	96"	1,320'	5/8"
1913	Crogham N. Y.	114"	2,555'	—
1913	Altman, N. Y.	138"	1,194'	5/8"
1914	Pittsburgh, Pa.	42"-48"	3,060'	—

YEAR INSTALLED	LOCATION	DIAMETER INCHES	FOOTAGE	THICKNESS
1914	Gardena, Cal.	12"-4"	—	16 Ga.
1914	Glendora, Cal.	8"	1,984'	14 Ga.
1914	Glendora, Cal.	12"	3,300'	12 Ga.
1914	Minneapolis, Minn.	48"	11,970'	1/4"-1/2"
1914	Butte, Mont.	24"	12,950'	—
1914	New York, N. Y.	66"	12,500'	7/16"-1/2"
1914	Schenectady, N. Y.	36"	10,500'	3/8"
1914	Tacoma, Wash.	30"	550'	1/4"
1914	Winnipeg, Canada	36"	21,569'	1/4"
1914	Springfield, Mass.	42"	—	—
1914	Essex Junction, Vt.	108" & 36"	2,440'	—
1914	Rutland, Vt.	54"	2,750'	—
1914	Rochester, N. Y.	66" & 48"	1,120'	—
1914	Cleveland, Ohio	48"	,320'	—
1914	Massena, N. Y.	24"	22,000'	1/4"-3/8"
1914	Miami, Ariz.	152"	1,670'	—
1914	Riverside, Cal.	30"	35,000'	—
1915	Cleveland, Ohio	66"-72"	—	3,960'
1915	Oakdale, Cal.	12"	50,000'	14 Ga.
1915	Baltimore, Md.	84"	4,000'	7/16"
1915	Lewiston, Mont.	16"	30,000'	1/4"-3/16"
1915	Pittsburgh, Pa.	48"	3,900'	1/2"
1915	Greeley, Colo.	20"	5,280'	—
1915	Massena, N. Y.	24"	5,000'	5/16"3/8"
1915	Ogden, Utah	24"	7,250'	—
1915	Ottawa, Canada	51"	15,000'	—
1915	San Bernardino, Cal.	20"	3,500'	3/16"

Useful Publications

AWWA Manual M11 Steel Pipe —A Guide for Design and Installation.

Steel Plate Engineering Data Volume 1 — Steel Tanks for Liquid Storage.

Steel Plate Engineering Data Volume 2 — Useful Information on the Design of Plate Structures. Note Vol. 1 and 2 are in one document published by AISI/SPFA.

Steel Plate Engineering Data Volume 4 — Buried Steel Penstocks, Published by AISI/SPFA.

Steel Design Manual, Brockenbrough & Johnston, Published by U.S. Steel Corp.

Publications by SPFA:

Welded Pipe Fracture Toughness & Structural Performance, John Barsom, U.S. Steel
Demystifying Cathodic Protection, Donald Waters, PSG Corrosion Engineering, Inc./CORRPRO.

Proven Economic Performance of Cathodic Protection and Anticorrosion
Systems in the Water Pipeline Industry, James Noonan, Decision Point Engineering.

Critical Vacuum in Buried Thin-Wall Steel Pipes, Buried Structures Laboratory, Utah State
University, AISI, Dec. 1989.

Vacuum Design of Welded Steel Pipe Buried in Poor Soil, Reynold K. Watkins and George J.
Tupac, Hydraulics of Pipelines, Proceedings of the International Conference, June 12-15, 1994,
Phoenix, AZ.

The Effects of High-Strength Steel in the Design of Steel Water Pipe, Robert Card and Dennis
Dechant, Advances in Underground Pipeline Engineering, ASCE Second International Conference,
Bellevue, WA, June 25-28, 1995.

Specify the Right Steel for Your Steel Water Pipe, George Tupac, Advances in Underground
Pipeline Engineering, ASCE Second International Conference, Bellevue, WA, June 25-28, 1995.

Trench Widths for Buried Pipes, Reynold K. Watkins, Advances in Underground Pipeline
Engineering, ASCE Second International Conference, Bellevue, WA, June 25-28, 1995.

An Investigation into the History and Use of Welded Lap Joints for Steel Water Pipe, Reynold J.
Watkins, P.E., Robert J. Card, P.E. and Nash Williams, ASCE Pipelines 2006, Chicago, Ill.

Fundamentals of Weld Discontinuities and their Significance, C.D. Lundin, Welding Research
Council Bulletin No. 295, June 1984

Standards and Specifications

AWWA Standard	Title
C200-97	Steel Water Pipe
C203-02	Coal-Tar Coating and Lining
C205-00	Cement-Mortar Lining and Coating
C206-03	Field Welding
C207-01	Flanges
C208-01	Dimensions of Fabricated Fittings
C209-00	Cold-Applied Tape-Fittings
C210-03	Liquid-Epoxy Coating and Lining
C213-01	Fusion Bonded Coatings
C214-00	Cold-Applied Tape-Pipe
C215-04	Extruded Polyolefin Coatings
C216-00	Heat-Shrinkable Sleeves
C217-04	Petrolatum/Petroleum Coatings
C218-02	Coatings for Aboveground
C219-01	Bolted, Sleeve-Type Couplings
C220-97	Stainless Steel Pipe
C221-01	Fabricated Slip-Type Expansion Joints
C222-99	Polyurethane Coating and Lining
C223-02	Tapping Sleeves
C224-01	Polyamide Coatings
C225-03	Fused Polyethylene Coatings
C226 (C2CC)	Dimensions of Stainless Steel Fittings
C227-07	Bolted, Split Sleeve Couplings
C2BB	Stainless Steel Flanges
C2DD	Split Sleeve Couplings
C2EE	Fusion-Bonded Polyethylene Coatings
C602-06	Cement-Mortar Lining, In-place
C604 (C6ZZ)	Installation
M11-5th Edition	Steel Pipe Manual

Appendix B

PIPE O.D. (IN.)	WALL THICKNESS (IN.)	PIPE WEIGHT (LBS/LF)	WORKING PRESSURE BASED ON 50% OF FOLLOWING YIELD STRENGTHS				PIPE STIFFNESS EI/D^3 (PSI)	MOMENT OF INERTIA ABOUT PIPE AXIS .049 $(D^2-D_1^2)$ (IN ⁴)	SECTION MODULUS $S=I/C$ (IN ³)	WEIGHT OF WATER IN PIPE (LBS/LF)	SPAN (FT)* SIMPLE BEAM CAL- CULATION, PIPE FULL OF WATER, USING BENDING FIBER STRESS OF: 10,000 PSI
			36,000 (PSI)	42,000 (PSI)	46,000 (PSI)	52,000 (PSI)					
4.5	0.0747	3.5	598	697	764	863	11.44	2.5	1.1	6.4	27
	0.1046	4.9	837	976	1069	1209	31.40	3.5	1.5	6.3	30
	0.1345	6.3	1076	1255	1375	1554	66.75	4.4	2.0	6.1	32
	0.1875	8.6	1500	1750	1917	2167	180.84	5.9	2.6	5.8	35
6.625	0.0747	5.2	406	474	519	586	3.58	8.2	2.5	14.3	29
	0.1046	7.3	568	663	726	821	9.84	11.4	3.4	14.0	33
	0.1345	9.3	731	853	934	1056	20.92	14.4	4.4	13.7	35
	0.1875	12.9	1019	1189	1302	1472	56.67	19.6	5.9	13.3	39
	0.2500	17.0	1358	1585	1736	1962	134.34	25.4	7.7	12.8	41
8.625	0.1046	9.5	437	509	558	631	4.46	25.4	5.9	24.1	34
	0.1345	12.2	561	655	717	811	9.48	32.3	7.5	23.8	37
	0.1875	16.9	783	913	1000	1130	25.68	44.2	10.2	23.2	41
	0.2500	22.4	1043	1217	1333	1507	60.88	57.6	13.4	22.5	45
10.75	0.1046	11.9	350	409	448	506	2.30	49.5	9.2	37.8	35
	0.1345	15.3	450	525	576	651	4.90	63.1	11.7	37.4	39
	0.1875	21.2	628	733	802	907	13.27	86.6	16.1	36.6	43
	0.2500	28.1	837	977	1070	1209	31.44	113.5	21.1	35.8	47
12.75	0.1046	14.1	295	345	377	427	1.38	82.9	13.0	53.5	36
	0.1345	18.1	380	443	485	549	2.93	105.9	16.6	53.0	39
	0.1875	25.2	529	618	676	765	7.95	145.8	22.9	52.1	44
	0.2500	33.4	706	824	902	1020	18.85	191.5	30.0	51.1	49
14	0.1046	15.5	269	314	344	389	1.04	110.0	15.7	64.7	36
	0.1345	19.9	346	404	442	500	2.22	140.6	20.1	64.2	40
	0.1875	27.7	482	563	616	696	6.01	193.7	27.7	63.2	45
	0.2500	36.7	643	750	821	929	14.24	254.8	36.4	62.0	50
16	0.1046	17.8	235	275	301	340	0.70	164.7	20.6	84.9	37
	0.1345	22.8	303	353	387	437	1.49	210.6	26.3	84.2	40
	0.1875	31.7	422	492	539	609	4.02	290.6	36.3	83.1	46
	0.2500	42.1	563	656	719	813	9.54	383.0	47.9	81.8	51
	0.3125	52.4	703	820	898	1016	18.63	473.1	59.1	80.5	54
	0.375	62.6	844	984	1078	1219	32.19	561.1	70.1	79.2	57
18	0.1046	20.0	209	244	267	302	0.49	235.0	26.1	107.7	37
	0.1345	25.7	269	314	344	389	1.04	300.7	33.4	107.0	41
	0.1875	35.7	375	438	479	542	2.83	415.4	46.2	105.7	47
	0.2500	47.4	500	583	639	722	6.70	548.2	60.9	104.2	52
	0.3125	59.1	625	729	799	903	13.08	678.1	75.3	102.7	56
	0.375	70.7	750	875	958	1083	22.61	805.2	89.5	101.3	59
20	0.1046	22.2	188	220	241	272	0.36	322.9	32.3	133.3	37
	0.1345	28.6	242	282	309	350	0.76	413.4	41.3	132.5	41
	0.1875	39.7	338	394	431	488	2.06	571.7	57.2	131.1	47
	0.2500	52.8	450	525	575	650	4.88	755.1	75.5	129.4	53
	0.3125	65.8	563	656	719	813	9.54	935.0	93.5	127.8	57
	0.3750	78.7	675	788	863	975	16.48	1111.5	111.1	126.1	60
22	0.1046	24.5	171	200	219	247	0.27	430.4	39.1	161.6	37
	0.1345	31.4	220	257	281	318	0.57	551.2	50.1	160.7	42
	0.1875	43.7	307	358	392	443	1.55	762.8	69.3	159.2	48
	0.2500	58.1	409	477	523	591	3.67	1008.5	91.7	157.3	53
	0.3125	72.4	511	597	653	739	7.17	1249.8	113.6	155.5	58
	0.3750	86.7	614	716	784	886	12.38	1487.0	135.2	153.7	61
	0.4375	100.8	716	835	915	1034	19.66	1720.0	156.4	151.9	64

PIPE O.D. (IN.)	WALL THICKNESS (IN.)	PIPE WEIGHT (LBS/LF)	WORKING PRESSURE BASED ON 50% OF FOLLOWING YIELD STRENGTHS				PIPE STIFFNESS EI/D ³ (PSI)	MOMENT OF INERTIA ABOUT PIPE AXIS .049 (D ⁴ -D ₁ ⁴) (IN ⁴)	SECTION MODULUS S=I/C (IN ³)	WEIGHT OF WATER IN PIPE (LBS/LF)	SPAN (FT)* SIMPLE BEAM CAL- CULATION, PIPE FULL OF WATER, USING BENDING FIBER STRESS OF: 10,000 PSI
			36,000 (PSI)	42,000 (PSI)	46,000 (PSI)	52,000 (PSI)					
			24	0.1345 0.1875 0.2500 0.3125 0.3750 0.4375 0.5000	34.3 47.7 63.5 79.1 94.7 110.2 125.6	202 281 375 469 563 656 750					
26	0.1345 0.1875 0.2500 0.3125 0.3750 0.4375 0.5000	37.2 51.7 68.8 85.8 102.7 119.6 136.3	186 260 346 433 519 606 692	217 303 404 505 606 707 808	238 332 442 553 663 774 885	269 375 500 625 750 875 1000	0.35 0.94 2.22 4.34 7.50 11.91 17.78	912.4 1264.2 1673.4 2076.7 2474.0 2865.5 3251.2	70.2 97.2 128.7 159.7 190.3 220.4 250.1	225.3 223.5 221.3 219.1 217.0 214.8 212.7	42 49 54 59 63 66 69
28	0.1345 0.1875 0.2500 0.3125 0.3750 0.4375 0.5000	40.1 55.7 74.2 92.5 110.7 128.9 147.0	173 241 321 402 482 563 643	202 281 375 469 563 656 750	221 308 411 513 616 719 821	250 348 464 580 696 813 929	0.28 0.75 1.78 3.48 6.01 9.54 14.24	1140.8 1581.3 2094.4 2600.4 3099.6 3591.9 4077.5	81.5 113.0 149.6 185.7 221.4 256.6 291.3	261.7 259.7 257.4 255.0 252.7 250.4 248.1	42 49 55 60 64 67 70
30	0.1345 0.1875 0.2500 0.3125 0.3750 0.4375 0.5000 0.6250	42.9 59.8 79.5 99.2 118.8 138.3 157.7 196.3	161 225 300 375 450 525 600 750	188 263 350 438 525 613 700 875	206 288 383 479 575 671 767 958	233 325 433 542 650 758 867 1083	0.23 0.61 1.45 2.83 4.88 7.75 11.57 22.61	1404.5 1947.6 2580.6 3205.6 3822.6 4431.8 5033.2 6212.9	93.6 129.8 172.0 213.7 254.8 295.5 335.5 414.2	300.8 298.7 296.2 293.7 291.2 288.7 286.2 281.3	43 49 55 60 64 68 71 76
32	0.1345 0.1875 0.2500 0.3125 0.3750 0.4375 0.5000 0.6250	45.8 63.8 84.9 105.9 126.8 147.6 168.4 209.6	151 211 281 352 422 492 563 703	177 246 328 410 492 574 656 820	193 270 359 449 539 629 719 898	219 305 406 508 609 711 813 1016	0.19 0.50 1.19 2.33 4.02 6.39 9.54 18.63	1706.0 2366.4 3136.8 3898.0 4650.2 5393.4 6127.7 7569.9	106.6 147.9 196.0 243.6 290.6 337.1 383.0 473.1	342.7 340.4 337.7 335.0 332.4 329.7 327.1 321.8	43 49 56 61 65 69 72 77
34	0.1345 0.1875 0.2500 0.3125 0.3750 0.4375 0.5000 0.6250	48.7 67.8 90.2 112.5 134.8 157.0 179.1 223.0	142 199 265 331 397 463 529 662	166 232 309 386 463 540 618 772	182 254 338 423 507 592 676 846	206 287 382 478 574 669 765 956	0.15 0.42 0.99 1.94 3.35 5.33 7.95 15.53	2047.8 2841.4 3767.7 4683.6 5589.3 6484.9 7370.3 9111.3	120.5 167.1 221.6 275.5 328.8 381.5 433.5 536.0	387.2 384.8 381.9 379.1 376.3 373.4 370.6 365.0	43 50 56 61 65 69 73 78
36	0.1345 0.1875 0.2500 0.3125 0.3750 0.4375 0.5000 0.6250	51.6 71.8 95.5 119.2 142.8 166.3 189.7 236.3	135 188 250 313 375 438 500 625	157 219 292 365 438 510 583 729	172 240 319 399 479 559 639 799	194 271 361 451 542 632 722 903	0.13 0.35 0.84 1.64 2.83 4.49 6.70 13.08	2432.5 3376.0 4477.9 5568.2 6647.1 7714.5 8770.6 10849.0	135.1 187.6 248.8 309.3 369.3 428.6 487.3 602.7	434.5 431.9 428.9 425.9 422.9 419.9 416.9 411.0	43 50 56 62 66 70 73 79

PIPE O.D. (IN.)	WALL THICKNESS (IN.)	PIPE WEIGHT (LBS/LF)	WORKING PRESSURE BASED ON 50% OF FOLLOWING YIELD STRENGTHS				PIPE STIFFNESS EI/D^3 (PSI)	MOMENT OF INERTIA ABOUT PIPE AXIS .049 $(D^4-D_1^4)$ (IN ⁴)	SECTION MODULUS $S=I/C$ (IN ³)	WEIGHT OF WATER IN PIPE (LBS/LF)	SPAN (FT)* SIMPLE BEAM CAL- CULATION, PIPE FULL OF WATER, USING BENDING FIBER STRESS OF: 10,000 PSI
			36,000 (PSI)	42,000 (PSI)	46,000 (PSI)	52,000 (PSI)					
			38	0.1345 0.1875 0.2500 0.3125 0.3750 0.4375 0.5000 0.6250	54.4 75.8 100.9 125.9 150.8 175.7 200.4 249.7	127 178 237 296 355 414 474 592					
40	0.1345 0.1875 0.2500 0.3125 0.3750 0.4375 0.5000 0.6250	57.3 79.8 106.2 132.6 158.8 185.0 211.1 263.1	121 169 225 281 338 394 450 563	141 197 263 328 394 459 525 656	155 216 288 359 431 503 575 719	175 244 325 406 488 569 650 813	0.10 0.26 0.61 1.19 2.06 3.27 4.88 9.54	3340.4 4638.3 6155.4 7658.2 9146.7 10621.1 12081.4 14960.2	167.0 231.9 307.8 382.9 457.3 531.1 604.1 748.0	537.2 534.4 531.0 527.7 524.3 521.0 517.7 511.0	43 50 57 62 67 71 74 80
42	0.1345 0.1875 0.2500 0.3125 0.3750 0.4375 0.5000 0.6250	60.2 83.8 111.6 139.3 166.9 194.4 221.8 276.4	115 161 214 268 321 375 429 536	135 188 250 313 375 438 500 625	147 205 274 342 411 479 548 685	167 232 310 387 464 542 619 774	0.08 0.22 0.53 1.03 1.78 2.83 4.22 8.24	3868.8 5373.0 7132.0 8875.2 10602.7 12314.5 14010.8 17357.2	184.2 255.9 339.6 422.6 504.9 586.4 667.2 826.5	592.7 589.7 586.1 582.6 579.1 575.6 572.1 565.2	43 50 57 62 67 71 75 81
48	0.1345 0.1875 0.2500 0.3125 0.3750 0.4375 0.5000 0.6250 0.7500	68.8 95.8 127.6 159.3 190.9 222.4 253.9 316.5 378.8	101 141 188 234 281 328 375 469 563	118 164 219 273 328 383 438 547 656	129 180 240 299 359 419 479 599 719	146 203 271 339 406 474 542 677 813	0.06 0.15 0.35 0.69 1.19 1.89 2.83 5.52 9.54	5782.0 8033.8 10669.8 13285.2 15880.0 18454.2 21008.0 26054.9 31021.5	240.9 334.7 444.6 553.6 661.7 768.9 875.3 1085.6 1292.6	775.4 771.9 767.9 763.9 759.8 755.8 751.8 743.8 735.9	44 51 58 63 68 72 76 83 88
54	0.2500 0.3125 0.3750 0.4375 0.5000 0.6250 0.7500	143.6 179.3 215.0 250.5 286.0 356.6 426.9	167 208 250 292 333 417 500	194 243 292 340 389 486 583	213 266 319 373 426 532 639	241 301 361 421 481 602 722	0.25 0.48 0.84 1.33 1.98 3.88 6.70	15218.5 18957.0 22669.4 26355.8 30016.2 37259.7 44401.0	563.6 702.1 839.6 976.1 1111.7 1380.0 1644.5	974.1 969.6 965.1 960.5 956.0 947.0 938.1	58 64 69 73 77 84 90
60	0.2500 0.3125 0.3750 0.4375 0.5000 0.6250 0.7500	159.7 199.4 239.0 278.6 318.0 396.7 475.0	150 188 225 263 300 375 450	175 219 263 306 350 438 525	192 240 288 335 383 479 575	217 271 325 379 433 542 650	0.18 0.35 0.61 0.97 1.45 2.83 4.88	20904.9 26049.4 31161.6 36241.5 41289.3 51289.1 61162.0	696.8 868.3 1038.7 1208.1 1376.3 1709.6 2038.7	1204.9 1199.8 1194.8 1189.7 1184.7 1174.7 1164.7	58 64 69 74 78 85 91
66	0.2500 0.3125 0.3750 0.4375 0.5000 0.6250 0.7500 0.8750	175.7 219.4 263.1 306.6 350.1 436.8 523.1 609.2	136 170 205 239 273 341 409 477	159 199 239 278 318 398 477 557	174 218 261 305 348 436 523 610	197 246 295 345 394 492 591 689	0.14 0.27 0.46 0.73 1.09 2.12 3.67 5.83	27856.1 34721.2 41547.0 48333.7 55081.4 68460.6 81685.7 94758.0	844.1 1052.2 1259.0 1464.7 1669.1 2074.6 2475.3 2871.5	1460.1 1454.6 1449.0 1443.5 1437.9 1426.9 1415.9 1404.9	59 65 70 75 79 86 92 97

PIPE O.D. (IN.)	WALL THICKNESS (IN.)	PIPE WEIGHT (LBS/LF)	WORKING PRESSURE BASED ON 50% OF FOLLOWING YIELD STRENGTHS				PIPE STIFFNESS EI/D ³ (PSI)	MOMENT OF INERTIA ABOUT PIPE AXIS .049 (D ⁴ -D ₁ ⁴) (IN ⁴)	SECTION MODULUS S=I/C (IN ³)	WEIGHT OF WATER IN PIPE (LBS/LF)	SPAN (FT)* SIMPLE BEAM CAL- CULATION, PIPE FULL OF WATER, USING BENDING FIBER STRESS OF: 10,000 PSI
			36,000 (PSI)	42,000 (PSI)	46,000 (PSI)	52,000 (PSI)					
			72	0.2500 0.3125 0.3750 0.4375 0.5000 0.6250 0.7500 0.8750	191.8 239.5 287.1 334.7 382.2 476.9 571.2 665.3	125 156 188 219 250 313 375 438					
78	0.2500 0.3125 0.3750 0.4375 0.5000 0.6250 0.7500 0.8750	207.8 259.5 311.2 362.8 414.2 517.0 619.4 721.4	115 144 173 202 231 288 346 404	135 168 202 236 269 337 404 471	147 184 221 258 295 369 442 516	167 208 250 292 333 417 500 583	0.08 0.16 0.28 0.44 0.66 1.29 2.22 3.53	46060.8 57437.6 68759.4 80026.4 91238.7 113500.1 135545.1 157374.9	1181.0 1472.8 1763.1 2052.0 2339.5 2910.3 3475.5 4035.3	2044.2 2037.6 2031.0 2024.4 2017.9 2004.8 1991.8 1978.8	59 65 71 76 80 88 94 100
84	0.2500 0.3125 0.3750 0.4375 0.5000 0.6250 0.7500 0.8750	223.8 279.6 335.2 390.8 446.3 557.0 667.5 777.5	107 134 161 188 214 268 321 375	125 156 188 219 250 313 375 438	137 171 205 240 274 342 411 479	155 193 232 271 310 387 464 542	0.07 0.13 0.22 0.35 0.53 1.03 1.78 2.83	57568.4 71799.9 85967.5 100071.5 114111.9 142003.2 169642.7 197032.2	1370.7 1709.5 2046.8 2382.7 2717.0 3381.0 4039.1 4691.2	2372.9 2365.8 2358.7 2351.7 2344.6 2330.5 2316.4 2302.4	59 66 71 76 81 88 95 101
90	0.3125 0.3750 0.4375 0.5000 0.6250 0.7500 0.8750 1.0000	299.6 359.3 418.9 478.4 597.1 715.6 833.7 951.4	125 150 175 200 250 300 350 400	146 175 204 233 292 350 408 467	160 192 224 256 319 383 447 511	181 217 253 289 361 433 506 578	0.10 0.18 0.29 0.43 0.84 1.45 2.30 3.43	88376.6 105830.9 123212.0 140520.2 174918.4 209027.1 242848.0 276382.7	1963.9 2351.8 2738.0 3122.7 3887.1 4645.0 5396.6 6141.8	2718.6 2711.0 2703.4 2695.8 2680.7 2665.6 2650.6 2635.6	66 71 76 81 89 96 102 107
96	0.3125 0.3750 0.4375 0.5000 0.6250 0.7500 0.8750 1.0000	319.7 383.3 446.9 510.4 637.2 763.7 889.8 1015.6	117 141 164 188 234 281 328 375	137 164 191 219 273 328 383 438	150 180 210 240 299 359 419 479	169 203 237 271 339 406 474 542	0.09 0.15 0.24 0.35 0.69 1.19 1.89 2.83	107326.3 128540.0 149670.3 170717.5 212563.4 254079.3 295267.0 336128.2	2236.0 2677.9 3118.1 3556.6 4428.4 5293.3 6151.4 7002.7	3095.9 3087.7 3079.6 3071.6 3055.4 3039.3 3023.3 3007.2	66 72 77 81 89 96 102 108
102	0.3125 0.3750 0.4375 0.5000 0.6250 0.7500 0.8750 1.0000	339.7 407.4 475.0 542.5 677.3 811.8 945.9 1079.7	110 132 154 176 221 265 309 353	129 154 180 206 257 309 360 412	141 169 197 225 282 338 395 451	159 191 223 255 319 382 446 510	0.07 0.12 0.20 0.29 0.58 0.99 1.58 2.36	128808.0 154285.4 179668.7 204957.9 255255.5 305180.1 354733.5 403917.6	2525.6 3025.2 3522.9 4018.8 5005.0 5983.9 6955.6 7920.0	3497.6 3489.0 3480.4 3471.8 3454.6 3437.5 3420.4 3403.4	66 72 77 82 90 97 103 109
108	0.3750 0.4375 0.5000 0.6250 0.7500 0.8750 1.0000	431.4 503.1 574.6 717.4 859.9 1002.0 1143.8	125 146 167 208 250 292 333	146 170 194 243 292 340 389	160 186 213 266 319 373 426	181 211 241 301 361 421 481	0.10 0.17 0.25 0.48 0.84 1.33 1.98	183257.6 213429.3 243495.5 303312.5 362710.8 421692.2 480258.8	3393.7 3952.4 4509.2 5616.9 6716.9 7809.1 8893.7	3914.8 3905.7 3896.5 3878.4 3860.2 3842.1 3824.1	72 77 82 90 97 104 109

PIPE O.D. (IN.)	WALL THICKNESS (IN.)	PIPE WEIGHT (LBS/LF)	WORKING PRESSURE BASED ON 50% OF FOLLOWING YIELD STRENGTHS				PIPE STIFFNESS EI/D ³ (PSI)	MOMENT OF INERTIA ABOUT PIPE AXIS .049 (D ⁴ -D ₁ ⁴) (IN ⁴)	SECTION MODULUS S=I/C (IN ³)	WEIGHT OF WATER IN PIPE (LBS/LF)	SPAN (FT)* SIMPLE BEAM CAL- CULATION, PIPE FULL OF WATER, USING BENDING FIBER STRESS OF: 10,000 PSI
			36,000 (PSI)	42,000 (PSI)	46,000 (PSI)	52,000 (PSI)					
114	0.3750	455.5	118	138	151	171	0.09	215647.2	3783.3	4365.0	72
	0.4375	531.1	138	161	177	200	0.14	251174.4	4406.6	4355.4	78
	0.5000	606.7	158	184	202	228	0.21	286584.1	5027.8	4345.8	82
	0.6250	757.5	197	230	252	285	0.41	357051.8	6264.1	4326.6	91
	0.7500	908.0	237	276	303	342	0.71	427052.2	7492.1	4307.4	98
	0.8750	1058.1	276	322	353	399	1.13	496587.6	8712.1	4288.3	104
	1.0000	1208.0	316	368	404	456	1.69	565659.9	9923.9	4269.2	110
120	0.3750	479.5	113	131	144	163	0.08	251644.5	4194.1	4839.8	73
	0.4375	559.2	131	153	168	190	0.12	293126.4	4885.4	4829.7	78
	0.5000	638.7	150	175	192	217	0.18	334477.9	5574.6	4819.5	83
	0.6250	797.6	188	219	240	271	0.35	416790.8	6946.5	4799.3	91
	0.7500	956.1	225	263	288	325	0.61	498585.5	8309.8	4779.1	98
	0.8750	1114.3	263	306	335	379	0.97	579864.2	9664.4	4759.0	105
126	0.4375	587.2	125	146	160	181	0.10	339507.4	5389.0	5328.4	78
	0.5000	670.8	143	167	183	206	0.16	387430.8	6149.7	5317.8	83
	0.6250	837.7	179	208	228	258	0.31	482847.2	7664.2	5296.6	91
	0.7500	1004.2	214	250	274	310	0.53	577691.7	9169.7	5275.3	99
	0.8750	1170.4	250	292	319	361	0.84	671966.5	10666.1	5254.2	105
	1.0000	1336.3	286	333	365	413	1.25	765674.0	12153.6	5233.1	111
132	0.4375	615.3	119	139	152	172	0.09	390539.8	5917.3	5851.7	78
	0.5000	702.9	136	159	174	197	0.14	445696.9	6753.0	5840.6	83
	0.6250	877.7	170	199	218	246	0.27	555538.4	8417.2	5818.3	92
	0.7500	1052.3	205	239	261	295	0.46	664751.7	10072.0	5796.1	99
	0.8750	1226.5	239	278	305	345	0.73	773339.1	11717.3	5773.9	106
	1.0000	1400.4	273	318	348	394	1.09	881303.0	13353.1	5751.7	112
138	0.4375	643.4	114	133	146	165	0.08	446445.8	6470.2	6399.5	78
	0.5000	734.9	130	152	167	188	0.12	509530.2	7384.5	6387.8	83
	0.6250	917.8	163	190	208	236	0.23	635182.0	9205.5	6364.5	92
	0.7500	1100.4	196	228	250	283	0.40	760146.6	11016.6	6341.3	99
	0.8750	1282.6	228	266	292	330	0.64	884426.5	12817.8	6318.1	106
	1.0000	1464.5	261	304	333	377	0.95	1008024.1	14609.0	6294.9	112
144	0.4375	671.4	109	128	140	158	0.07	507447.6	7047.9	6971.8	78
	0.5000	767.0	125	146	160	181	0.10	579184.7	8044.2	6959.6	83
	0.6250	957.9	156	182	200	226	0.20	722095.5	10029.1	6935.3	92
	0.7500	1148.5	188	219	240	271	0.35	864257.4	12003.6	6911.0	100
	0.8750	1338.8	219	255	280	316	0.56	1005673.1	13967.7	6886.8	106
	1.0000	1528.7	250	292	319	361	0.84	1146345.2	15921.5	6862.6	112
150	0.4375	699.5	105	123	134	152	0.06	573767.6	7650.2	7568.6	79
	0.5000	799.1	120	140	153	173	0.09	654914.4	8732.2	7555.9	83
	0.6250	998.0	150	175	192	217	0.18	816596.4	10888.0	7530.5	92
	0.7500	1196.6	180	210	230	260	0.31	977465.2	13032.9	7505.2	100
	0.8750	1394.9	210	245	268	303	0.50	1137523.7	15167.0	7480.0	107
	1.0000	1592.8	240	280	307	347	0.74	1296774.4	17290.3	7454.8	113
156	0.4375	727.5	101	118	129	146	0.06	645627.9	8277.3	8189.8	79
	0.5000	831.1	115	135	147	167	0.08	736973.3	9448.4	8176.6	84
	0.6250	1038.1	144	168	184	208	0.16	919002.2	11782.1	8150.3	92
	0.7500	1244.7	173	202	221	250	0.28	1100151.0	14104.5	8124.0	100
	0.8750	1451.0	202	236	258	292	0.44	1280422.6	16415.7	8097.7	107
	1.0000	1657.0	231	269	295	333	0.66	1459819.8	18715.6	8071.5	113

* Stresses at supports must also be considered.



**American
Iron and Steel
Institute**

1140 Connecticut Avenue NW
Suite 705
Washington DC 20036
202.452.7100
www.steel.org



**Steel Tank Institute/
Steel Plate Fabricators Association**
570 Oakwood Road
Lake Zurich, IL 60047
847.438.8265
www.steeltank.com
www.spfa.com

