



LINCOLN
ELECTRIC

LINCOLN
ELECTRIC

CUTTING

WELDING & CUTTING SOLUTIONS

The Lincoln Electric Company

Founded in 1895 by John C. Lincoln, The Lincoln Electric Company is the world leader in the design, development and manufacture of arc welding products, robotic arc welding systems, and plasma and oxyfuel cutting equipment, and has a leading global position in the brazing and soldering alloys market. Headquartered in Cleveland, Ohio, Lincoln Electric maintains a global network of manufacturing, distribution, sales and technical support covering more than 160 countries.

INNOVATION

With a long history of innovation in arc welding and cutting equipment, Lincoln Electric has been providing state-of-the-art products and comprehensive process solutions to our customers for more than a century. In the past decade, we have combined the resources and expertise of several leading companies – Torchmate, Vernon Tool, Burny Kaliburn, PythonX and others – to create a single cutting group to address every possible customer need. What's more, we've developed a worldwide network of R&D centers to oversee the most comprehensive research and product development program in the global welding and cutting industries.

CUSTOMER COMMITMENT AND SUPPORT

Lincoln Electric owes its position as an industry leader to an enduring combination of high-quality products, technical expertise and unwavering customer support. Whether you're welding, cutting, integrating an automated system into your existing operation or taking your existing automated system to a new level, we'll help you find a way to do it better and more cost-efficiently. If there's a way to improve your product and your bottom line, we'll show you how it can be done.



We are driven by customer satisfaction and known as the supplier of choice in the many industries we serve. We continuously strive to exceed customer expectations and are not simply known as a provider of equipment and consumables, but as a provider of complete welding and cutting solutions.

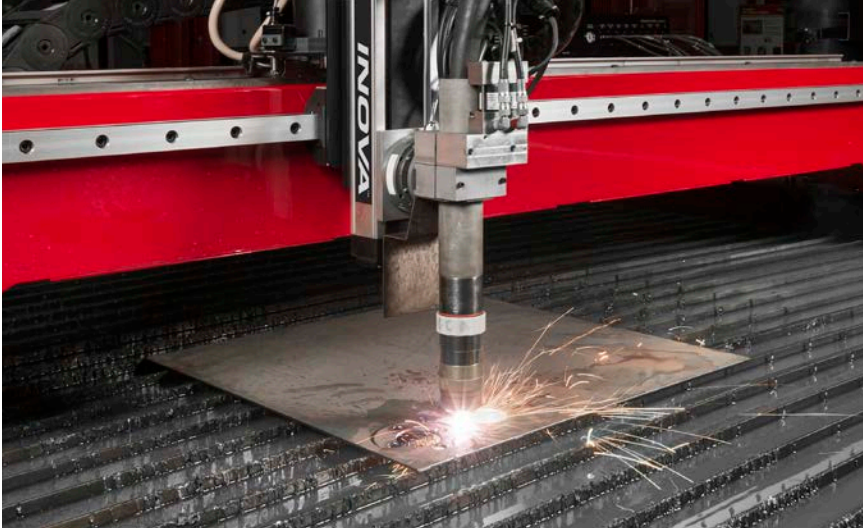

THE CUTTING INDUSTRY

Cutting Solutions to Meet the Most Demanding Requirements – Yours.

Lincoln Electric is no stranger to manufacturing. It's the arena in which we've maintained a leadership position for more than a century. Along the way, we've learned that leadership in manufacturing isn't just about welding technology. It's also about cutting technology, which is an integral process in virtually every industry: aerospace, automotive, machinery, mining, farming, construction, structural steel, oil, gas and more. No matter the application, no matter the material, no matter the shape, we have the systems and solutions that will enable you to make the cut.

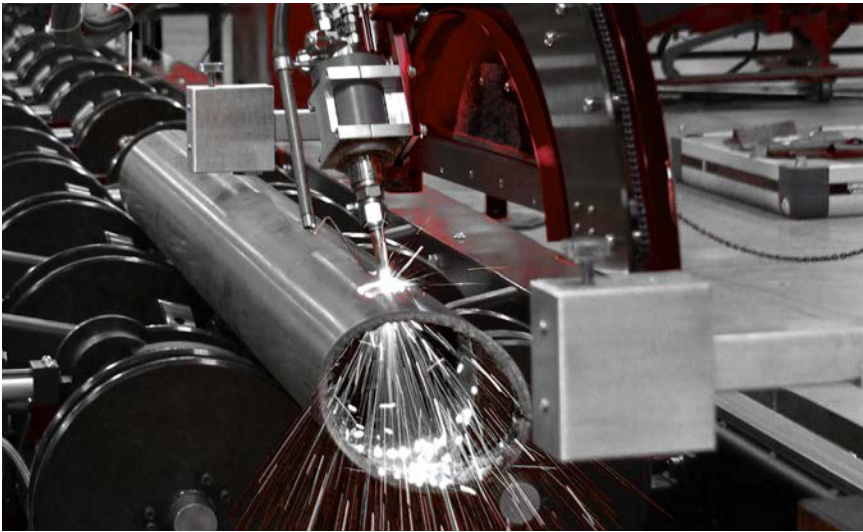

OUR MANY DIMENSIONS, YOUR SINGLE SOURCE

At every step in our evolution, we've focused on building a portfolio of expertise that encompasses every cutting application within the fabrication and industrial manufacturing universe: plasma cutting and motion control, plate cutting, tube and pipe cutting, structural steel cutting and more. Every segment of Lincoln Electric's overall business is directly aimed at providing solutions to the challenges you face every day. After all, cutting is about much more than just material separation. It's about material handling, robotics and automation, regulatory compliance, part quality and a host of other concerns. We're the one source and the one partner you'll ever need to address it all.

MEETING EVERY CHALLENGE

What started with welding many decades ago has evolved into a range of applications and solutions that apply to virtually every segment of the manufacturing process, including cutting. That's why Lincoln Electric invests in the largest application engineering, automation and R&D support centers in the industry. Highly trained and experienced technologists, engineers and applications personnel are available to not only troubleshoot customer problems in the field – anywhere in the world – but also develop new solutions based on whatever customer challenges we encounter. In the end, this industry-leading technical support team has one focus: providing you with the best cutting solutions for your specific needs.





Best-Fit Solutions

Plasma Cutting Equipment

- » Spirit II 150
- » Spirit II 275
- » Spirit II 400

Shape Cutting Controllers

- » Burny Phantom® II
- » Burny Phantom ST II
- » Burny 10LCD Plus™
- » ACCUMOVE® 2
- » ACCUMOVE 3

Shape Cutting Software

- » Burny 8 Shape Cutting CNC Software

Torch and Plasma Consumables

- » Quick-Disconnect Torch
- » Endura® Copper Electrode
- » EnduraX® Silver Electrode

PLASMA CUTTING AND MOTION CONTROL

A CUT ABOVE THE COMPETITION

When it comes to automated plasma cutting, maximizing output and productivity is essential to the operation that wants to remain competitive. Whether the material at hand is pipe, structural beam or flat plate, the plasma cutting system plays a critical role in achieving the best cut possible. If you're planning to stay in the game – and more importantly, stay ahead of the game – you need to do your plasma cutting at a high volume and you need to do it right the first time. You need cutting solutions from Lincoln Electric.

BURNY SHAPE CUTTING CONTROLLERS

The best CNC for an automated cutting system is the one built on a solid foundation. All Burny® shape cutting controllers now come with Burny 8 software. Burny 8, based on the Windows® 8 operating system, represents a leap forward in shape-cutting CNC software that streamlines and optimizes the operator's control of the plasma

cutting process. Burny 8 also puts UltraSharp® hole technology software at your fingertips, and gives you access to industry-leading technology to make bolt-ready holes. Through it all, the software maximizes security by enabling you to connect the Burny CNC to your company network, while maintaining compatibility with the latest versions of Microsoft's operating systems.

SPIRIT II PLASMA SYSTEMS

The Spirit® II system with FineLine™ High-Definition Plasma Cutting Technology delivers the best cut quality in the industry. Our combination of patented processes, along with torch and consumable designs, ensures a precise gas flow that creates a consistently shaped plasma arc. In addition, Spirit II incorporates longer-lasting consumables that are also designed to reduce plasma gas consumption by as much as 78%. It all adds up to reduced operating costs, improved production times, and easier operations.

PLATE CUTTING

SHAPE CUTTING LEADERS

Lincoln Electric delivers precise shape-cutting solutions for materials of various sizes up to 10 x 40 feet. Our ongoing commitment to the development and application of new cutting technologies spans more than three decades, and has resulted in improved precision and productivity in customer operations.

EVERYTHING ON THE TABLE

Our Torchmate family of cutting systems has been bringing affordable CNC plasma cutting tables and other automation solutions to manufacturers worldwide for more than thirty years. Our unmatched range of options and accessories enables us to tailor each machine to meet any customer's production requirements. Regardless of your process – plasma cutting, routing, engraving, oxyfuel cutting or whatever else is on your table – you can count on your Torchmate CNC system to deliver the highest level of precision and repeatability on the market.

TOTAL SOLUTIONS

Speed, accuracy and consistent repeatability of processes are critical to the success of an industrial manufacturing facility. Lincoln Electric leverages its experience across multiple platforms to develop plate-cutting systems that deliver best-in-class performance and efficiency. Whether the answer is a standard system or custom application, Lincoln Electric provides solutions for a broad range of partners: industrial manufacturers, structural steel contractors, maintenance facilities, fabricators, education, small business and you.



Lincoln Electric Cut Quality

- » 78% Less Plasma Gas Consumption
- » <2° of Cut Edge Bevel
- » 3 in. (75 mm) Mild Steel Cutting Capacity
- » UltraSharp Hole Technology
- » Virtually Dross-Free Cuts
- » Unparalleled Consumable Life





TUBE AND PIPE CUTTING

SAFE AND EFFICIENT PIPE HANDLING

Since the 1960s, Lincoln Electric's tube and pipe cutting business has been integrating powered pipe conveyors into turning roll machine beds. In that time, customers have reduced machine setup and material handling times by as much as 80%. Today, our pipe handling process is more efficient than ever: pipe is power-moved into the cutting area, then hydraulically lowered onto the powered turning rolls that control the cutting movement. Both the finished piece and the remnant are fully supported, rotated and moved without the need for additional labor or lifting devices. In the end, the operator can focus more attention on the business of cutting rather than handling and moving.



SAVE TIME, SAVE MONEY

Lincoln Electric can build efficiencies into any pipe-cutting operation that will save time and money. We develop systems and solutions that automatically produce ASME-specific weld prep angles while cutting any profile. In addition, we can assist in various aspects of field erection and rework, including offshore jackets, bridges and architectural space frames. We can help you create the clean cuts and tight fit-ups that are critical to offshore and structural support applications. In addition, we develop conveyor systems to arrange multiple pipe components for cutting in the exact order required. This enables the components to move, as in a production line, from raw storage to spool fabrication to the job site, employing quality-control measures at each step.



Pipe Profiles

- » Straight
- » Miter
- » Double-Miter
- » Saddle
- » Multi-Saddle
- » Multi-Saddle-Miter
- » Tee
- » Circular
- » Saw
- » Rectangle
- » Overlap
- » Gusset Slot
- » Pipe-to-Cone
- » Elbow Support

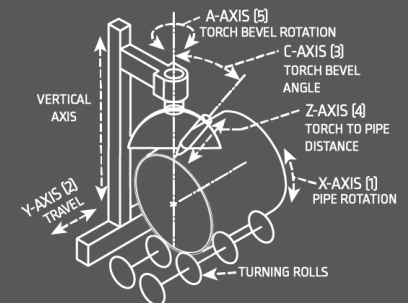

MPM5 AXIS DESIGNATION



STRUCTURAL STEEL

PYTHONX STRUCTURAL STEEL FABRICATION

Lincoln Electric's PythonX is a computer-controlled plasma cutting system that has revolutionized the process of structural steel fabrication. Traditional fabrication involves reading drawings, measurement and layout of the cuts, using drills, punches, saws, hand torches and hand stamps to fabricate a structural steel beam. It's a process that takes too much time and too much space, and it's prone to error. But PythonX has established a new standard in the way you think about running a fabrication shop. More than just a machine, it's the ideal marriage of advanced CNC robotics to high-definition plasma cutting, equipped with software so sophisticated it can program cuts by itself and eliminate the costs associated with the various intermediary steps. Load the beam on the infeed conveyor, open a part file and press the START button. All complex cuts along the entire length of the beam are finished in minutes rather than hours, with a minimum of material handling. For many fabrication shops, PythonX has become the system of choice. Make it your choice for structural steel fabrication.



PythonX replaces:

Traditional Machines

- » Drill Lines
- » Band Saws
- » Coping Machines
- » Angle Punches
- » Plate Machines
- » Marking Machines

PythonX fabricates:

- » Beams
- » Channels
- » HSS
- » Angle
- » Strip Plate

PythonX produces:

Best in Class Bolt Hole Quality

- » AISC approved bolt holes
- » Copes
- » Slots
- » Cutouts
- » Cut to length
- » Miter cuts
- » Produce T-Beams
- » Scribe part | Layout marks

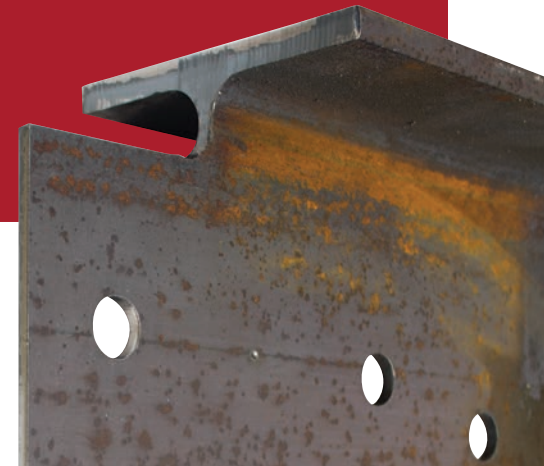

LINCOLN ELECTRIC
CUTTING LOCATIONS

CLEVELAND AUTOMATION

22221 Saint Clair Avenue
Cleveland, OH · 44117 · U.S.A.

RENO

1170 Trademark Drive, Suite 101
Reno, NV · 89521 · U.S.A.

LADSON

4130 Carolina Commerce Parkway
Ladson, SC · 29456 · U.S.A.

CANADA AUTOMATION

939 Gana Court
Mississauga, ONT · L5S 1N9 · Canada

BURLINGTON, CANADA

63 Innovation Drive
Hamilton, ONT · L9H 7L8 · Canada

MEXICO AUTOMATION

Carretera Agua Fria No. 1000
Parque Industrial Hasna II
CP 66600 · Apodaca, NL

GERMANY

ZNL der Lincoln Smitweld B.V.,
Nijmegen, Werkstrasse 5, 64732
Bad Koenig, Germany

CHINA

No 195, Lane 5008 Hu Tai Road
Baoshan Shanghai
PR CHINA

BRAZIL

Estrada General Motors, 852
Condominio Caldeira · Indaiatuba, SP
Brazil CEP · 1334-500



The Lincoln Electric Company
22801 St. Clair Avenue
Cleveland, OH 44117-1199 U.S.A.
www.lincolnelectriccutting.com

CUSTOMER ASSISTANCE POLICY

The business of The Lincoln Electric Company® is manufacturing and selling high quality welding equipment, consumables, and cutting equipment. Our challenge is to meet the needs of our customers and to exceed their expectations. On occasion, purchasers may ask Lincoln Electric for information or advice about their use of our products. Our employees respond to inquiries to the best of their ability based on information provided to them by the customers and the knowledge they may have concerning the application. Our employees, however, are not in a position to verify the information provided or to evaluate the engineering requirements for the particular weldment. Accordingly, Lincoln Electric does not warrant or guarantee or assume any liability with respect to such information or advice. Moreover, the provision of such information or advice does not create, expand, or alter any warranty on our products. Any express or implied warranty that might arise from the information or advice, including any implied warranty of merchantability or any warranty of fitness for any customers' particular purpose is specifically disclaimed.

Lincoln Electric is a responsive manufacturer, but the selection and use of specific products sold by Lincoln Electric is solely within the control of, and remains the sole responsibility of the customer. Many variables beyond the control of Lincoln Electric affect the results obtained in applying these types of fabrication methods and service requirements.

Subject to Change – This information is accurate to the best of our knowledge at the time of printing. Please refer to www.lincolnelectric.com for any updated information.