



Table of Content

- About Us** 4

- Drilling Systems** 7
 - Conventional Equipment 8
 - Casing Heads 10
 - Casing Spools 17
 - Casing Hangers 24
 - Secondary Seals 31
 - Tubing Heads 39
 - Test Plugs and Bowl Protectors 46
 - Lockdown Screws 49
 - Seal Technology 53

- Completion Systems** 61
 - HPT Gate Valves 62
 - VRC FRAC Heads 63
 - Modular FRAC Manifolds 64
 - Engineered FRAC Manifolds 65
 - FRAC Relief Valve Units 66
 - FRAC Accumulator Units 67
 - Test & Torque Units 68
 - FRAC Grease Units 69

Table of Content

- Production Systems** 70
 - Tubing Hangers 71
 - Tubing Head Adapters 82
 - Production Trees 95
 - Production Gate Valves 98
 - Crosses, Tees and Tree Caps 102
 - Production Configurations 107
 - Engineered Wellhead Systems 113

- Services** 117
 - Field Services 118
 - Base Services 123
 - Field Service Training 127

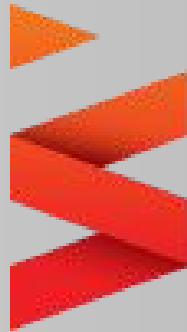

About Us

Our Vision

Sentry Wellhead Systems Vision Statement:

Delivering dependable products and services to our customers, through experienced people, reliable products and industry focused technologies.

Corporate Mission Statement:

Provide the continuous improvement needed through experienced and focused performance capabilities that set the Oil and Gas industry standard for service, quality and overall customer satisfaction.

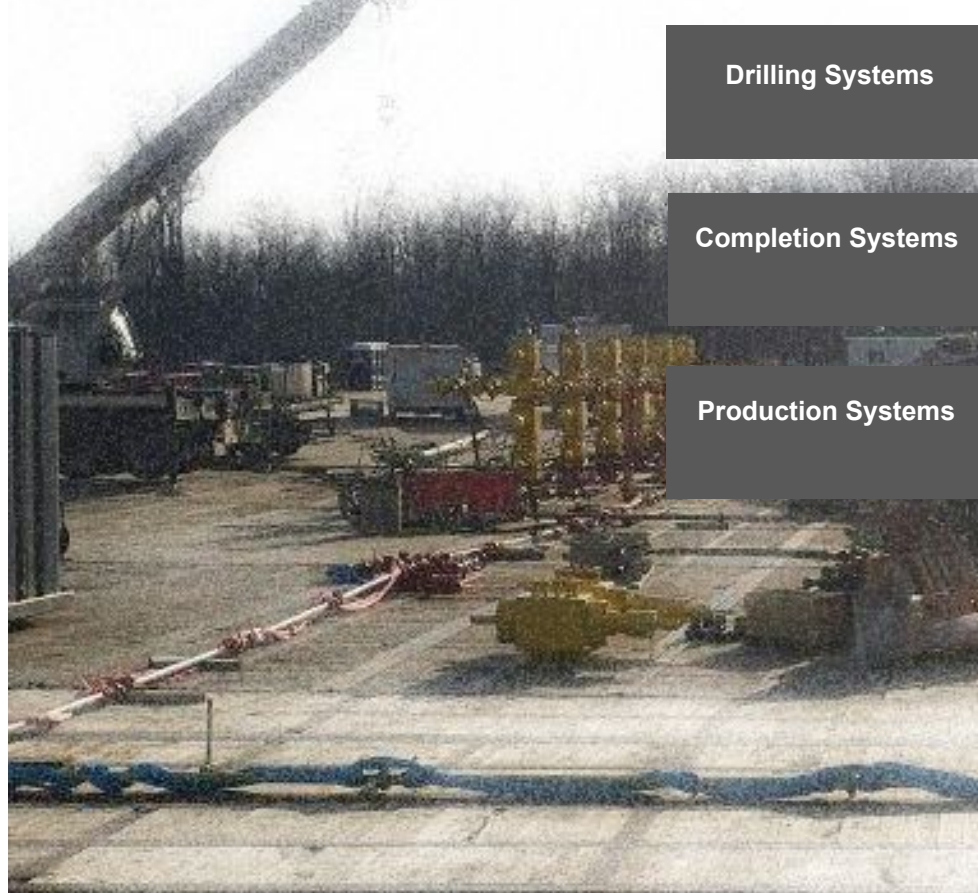

Discover the power of Performance Driven by Experience and Focus

Our company is proud to be recognized for its history of technological innovation and its reputation for customer service. But that's only a small window into the portal of Sentry Wellhead Systems.

You require products and services that are cost effective and reliable. You want the latest time saving applications, the best technology, and you want a company that has a great service and safety record. For these reasons, we've shaped our offerings to reflect your needs. We're advancing cutting edge time saving wellhead products and solutions.

If your requirements are for one of Sentry's engineered designs, we have systems constructed to lower your total installation costs and maximize your production.

However, you can use us for your conventional wellhead needs as well. Sentry maintains a strategically distributed inventory of standardized supported products to meet the needs of our customers.

Simplify the way you get things done and use the Guardians of Pressure Control for all of your Wellhead and FRAC equipment needs. We are committed to the continuous improvements needed to shape this industry and improve your experience with Sentry Wellhead Systems.



Our People

“Seek opportunities to show that you care. The smallest gestures often make the biggest difference.”

– John Wooden

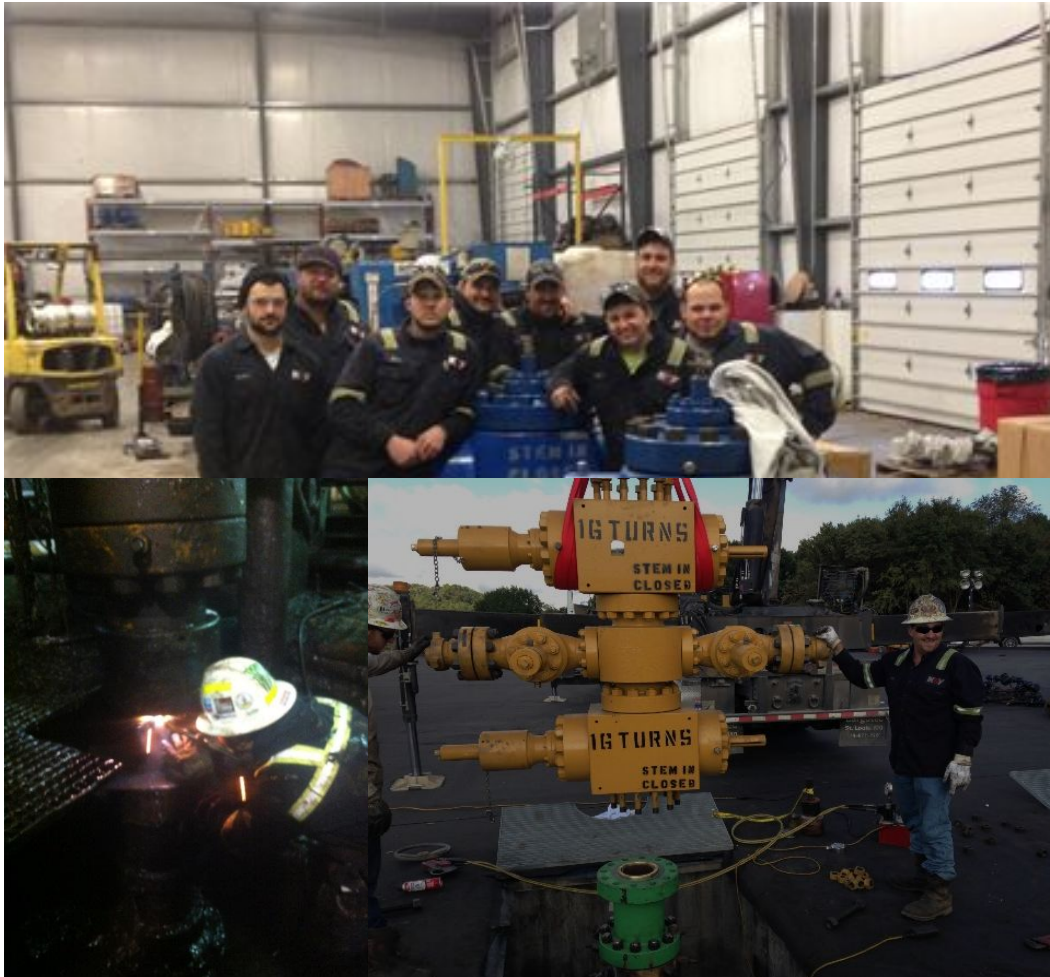

The Guardians of Pressure Control - Service. 24 Hours a day, 7 Days a week, 365 Days a year.

You require people that are dependable, well trained, team oriented and safe. Sentry makes a commitment to hire U.S. Veterans and provide them with the training and equipment to excel at this profession. Our service technicians undergo hands on technical training as well as scenario based training that fosters situational awareness. All apprentices attending Service Technician School, (STS) are provided a minimum of 120 days of classroom and field training prior to graduation.

Safety and technical training however do not completely cover the scope of all needs. Candidates for the position of Field Service Technician are selected on their ability to actively collaborate with others and work in a team based environment. They also receive training that allows them to understand and properly respond to customer relationships and needs.

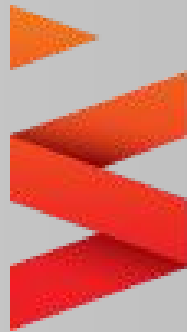

Drilling Systems



Conventional Equipment

Conventional Wellhead Systems

Conventional Systems

Sentry's conventional wellhead product line is available and strategically placed in the U.S. to meet the needs of our customers. Listed on the pages that follow are the casing heads and spools, casing hangers, secondary seals, tubing heads, tubing hangers, tubing head adapters and many other equipment categories. Details of or API 6A compliant conventional equipment are available for use at your convenience.

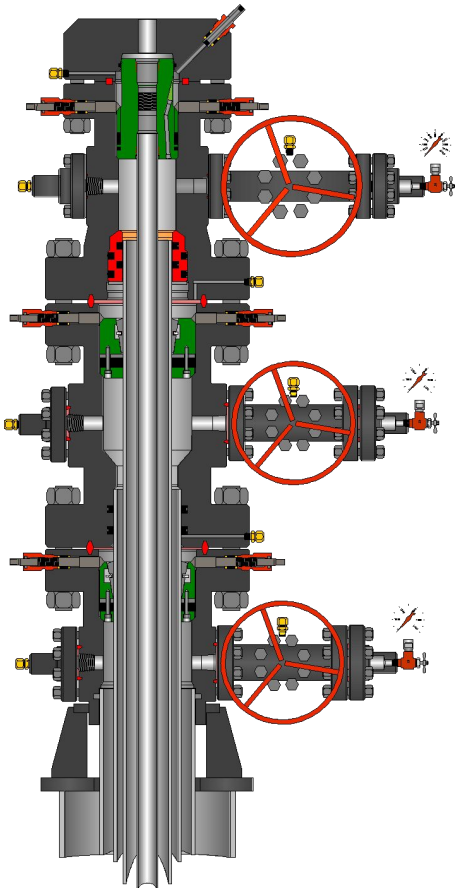

- Sentry conventional systems are traditionally cost effective
- Can easily be utilized for vertical or horizontal wells
- Employed with Short Radius, Sidetrack and Multi-lateral completions
- Can be used on water source wells
- Good for use on FRAC completions
- Available for use on thru-tubing completions
- Can be mixed and matched with other conventional equipment as need to meet customer requirements



Casing Heads

Casing Heads

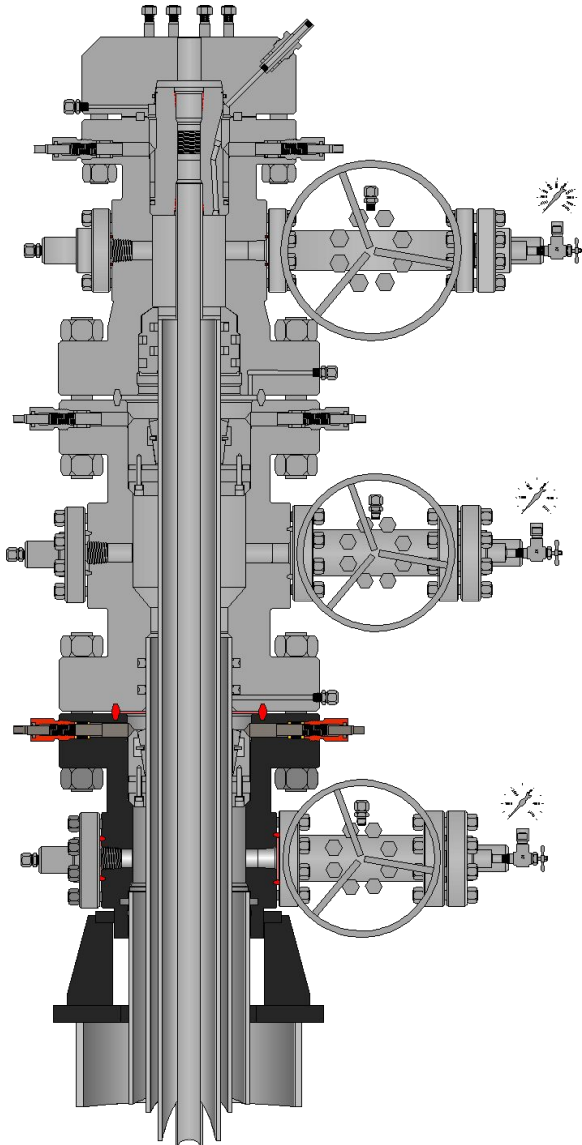

The casing head in a conventional wellhead system is the lowest part of the wellhead assembly and is almost always connected to the surface casing string. It supports the remaining parts of the wellhead and completion equipment. The casing head performs the following functions:

- Provides a means for attachment to the surface casing string
- Allows for suspending the next casing string, usually the first intermediate string in the well
- Supports the blowout preventers (BOP) while drilling
- Provides outlets for fluid returns
- Provides a means to test the blowout preventers (BOP) while drilling
- May provide a test port for testing welded or other non-threaded bottom casing head connections
- May also be referred to by the following names, “A-Section”, “Braden Head” or “Starting Head”

Casing Heads

Casing Head Components

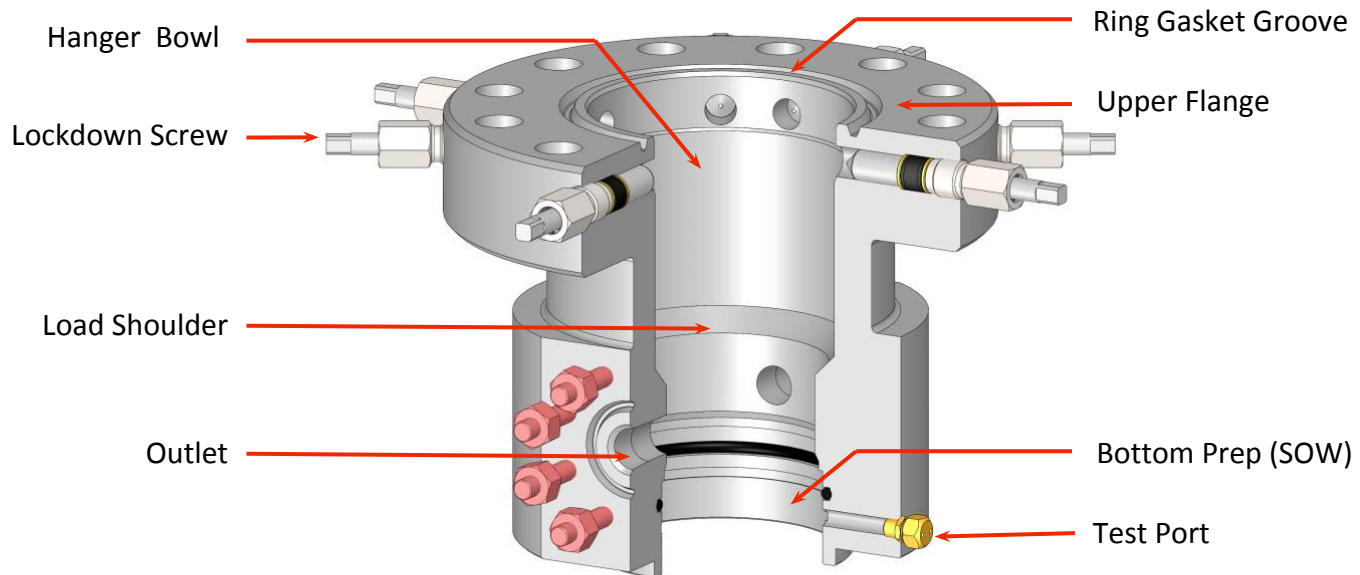

Casing Heads

Sentry C-22 Casing Heads

Sentry casing heads incorporate the industry workhorse C-22 geometry that will accept a standard C-21 or C-22 casing hanger. Additionally, the Sentry C-22 casing head product line has been engineered with the option to integrate full sets of lock-down screws (LDS) in the upper flange in order to provide mechanical casing hanger retention and/or pack-off actuation.

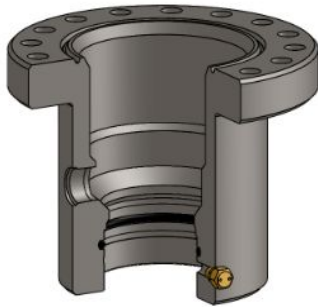

- The C-22 casing head is designed for light to intermediate casing string weights
- It incorporates a straight bowl design
- Is available with Lock Down Screws (LDS) in the upper flange for mechanical casing hanger retention
- Can utilize Bowl Protector lockdown screws
- It may be equipped with or without a baseplate
- Available in multiple bottom connection configurations including Slip-Lock

Bowl	Top Flange	WP	Bottom Connection (Threaded or SOW)	Outlet Size	PSL Levels	Material Classes
C-22	7"	3K, 5K	4-1/2" thru 7"	2" LPO or Studded	PSL 1 thru 3	AA, EE, FF
C-22	9"	3K, 5K	4-1/2" thru 8-5/8"	2" LPO or Studded	PSL 1 thru 3	AA, EE, FF
C-22	11"	3K, 5K	8-5/8" thru 10-3/4"	2" LPO or Studded	PSL 1 thru 3	AA, EE, FF
C-22	13-5/8"	3K, 5K	11-3/4" thru 13-3/8"	2" LPO or Studded	PSL 1 thru 3	AA, EE, FF
C-22	16-3/4"	3K, 5K	16"	2" LPO or Studded	PSL 1 thru 3	AA, EE, FF
C-22	18-5/8"	5K	18-5/8"	2" LPO or Studded	PSL 1 thru 3	AA, EE, FF
C-22	20-3/4"	3K	20"	2" LPO or Studded	PSL 1 thru 3	AA, EE, FF
C-22	21-1/4"	3K, 5K	20"	2" LPO or Studded	PSL 1 thru 3	AA, EE, FF



Casing Heads

Sentry C-29 Casing Heads

The Sentry C-29 casing head has all of the same features and benefits as the C-22, but is designed for intermediate to extreme casing weights. This head design can also handle the standard C-21 and C-22 casing hangers.

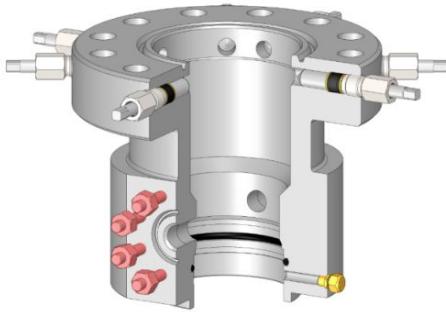

- The C-29 casing head is designed for intermediate to extreme casing loads
- It has a deeper upper bowl to accommodate the taller C-29 casing hanger
- The C-29 casing head can also utilize the C-21 and C-22 casing hangers
- Is available with Lock Down Screws (LDS) in the upper flange for mechanical casing hanger retention
- It may be equipped with or without a baseplate
- Available in multiple bottom connection configurations including Slip-Lock

Bowl	Top Flange	WP	Bottom Connection (Threaded or SOW)	Outlet Size	PSL Levels	Material Classes
C-29	7"	3K, 5K	4-1/2" thru 7"	2" LPO or Studded	PSL 1 thru 3	AA, EE, FF
C-29	9"	3K, 5K	4-1/2" thru 8-5/8"	2" LPO or Studded	PSL 1 thru 3	AA, EE, FF
C-29	11"	3K, 5K	8-5/8" thru 10-3/4"	2" LPO or Studded	PSL 1 thru 3	AA, EE, FF
C-29	13-5/8"	3K, 5K	11-3/4" thru 13-3/8"	2" LPO or Studded	PSL 1 thru 3	AA, EE, FF
C-29	16-3/4"	3K, 5K	16"	2" LPO or Studded	PSL 1 thru 3	AA, EE, FF
C-29	18-5/8"	5K	18-5/8"	2" LPO or Studded	PSL 1 thru 3	AA, EE, FF
C-29	20-3/4"	3K	20"	2" LPO or Studded	PSL 1 thru 3	AA, EE, FF
C-29	21-1/4"	3K, 5K	20"	2" LPO or Studded	PSL 1 thru 3	AA, EE, FF



Casing Heads

C-22 Casing Head Configurations

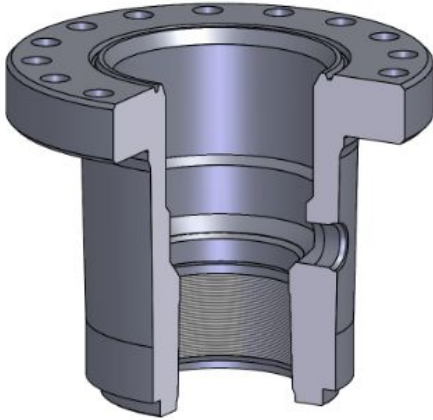

C-22 W/Threaded Bottom & Outlets

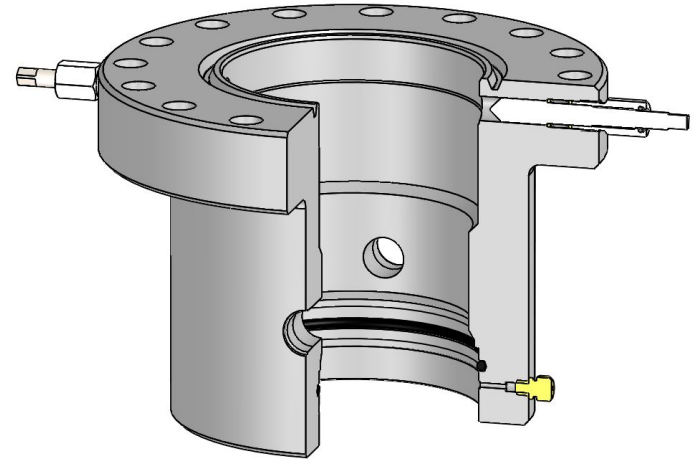

C-22-BP-ET W/SOW Bottom & Threaded Outlets

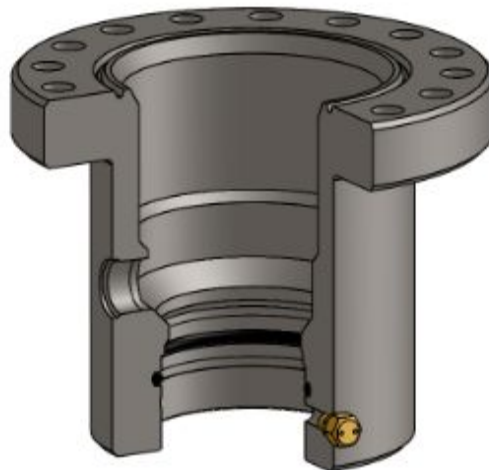

C-22 W/SOW Bottom & Threaded Outlets

Casing Heads

C-29 Casing Head Configurations

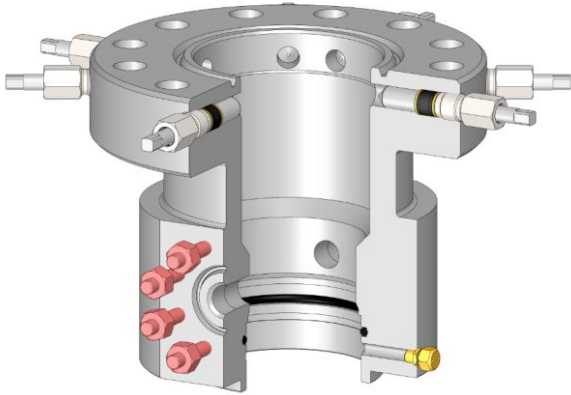

C-29-ET W/SOW Bottom & Studded Outlets

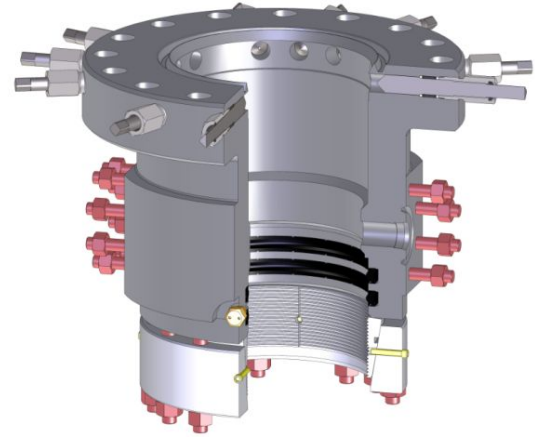

C-29-ET W/Studded Outlets & Slip-Loc Bottom

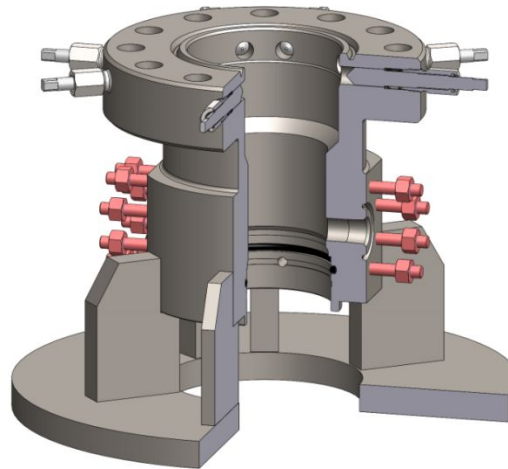

C-29-ET W/SOW Bottom, Studded Outlets & Baseplate



Casing Spools

Casing Spools

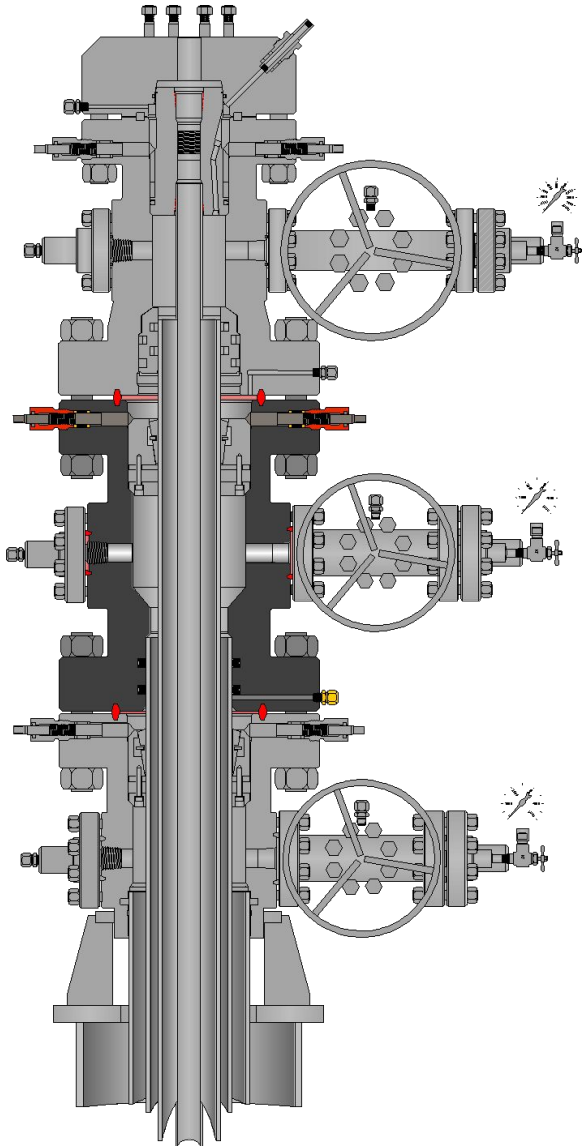

The casing spool in a conventional wellhead system is the component that allows for an additional string of casing to be set in the well. Depending on the casing program for the well, there can be one or more casing spools and they perform the following functions:

- Allows for suspending the next casing string in the well
- Supports the blowout preventers (BOP's) while drilling
- Provides outlets for fluid returns
- Provides a means to test the blowout preventers while drilling
- Has flanges on both the top and bottom of the assembly
- Has a seal area in the bottom flange for a secondary seal between the casing annulus and the flanged connection
- Utilize a test port in the bottom flange that allows for the secondary seal and the flanged connection to be pressure tested

Casing Spools

Casing Spool Components

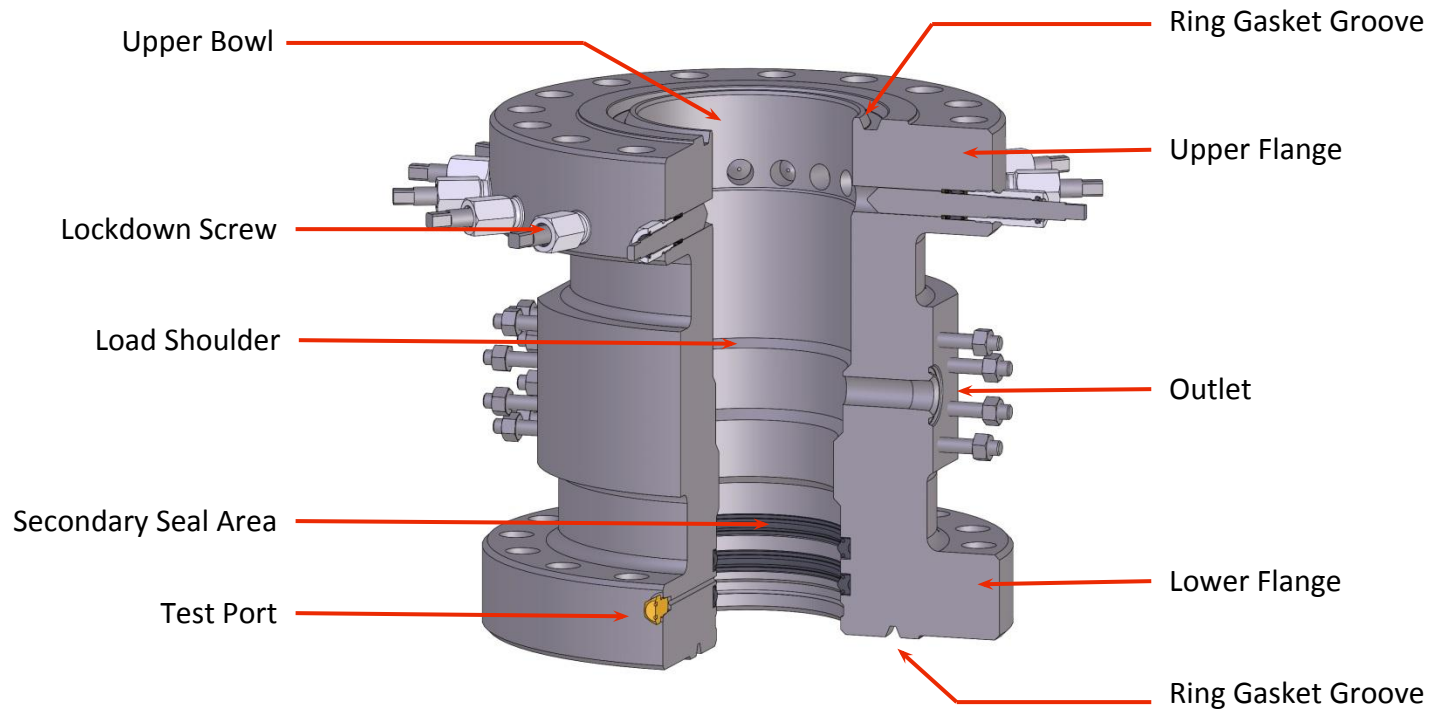

Casing Spools

Sentry C-22 Casing Spools

Sentry C-22 casing spools incorporate the industry workhorse C-22 geometry that will accept a standard C-21 or C-22 casing hanger. Additionally, the Sentry C-22 casing spool product line has been designed with the option to integrate full sets of lock-down screws (LDS) in the upper flange in order to provide mechanical casing hanger retention.

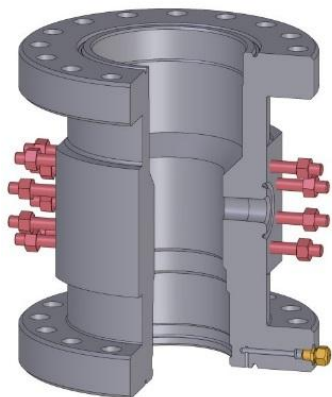

- The C-22 casing spool is designed for light to intermediate casing string weights
- It incorporates a straight bowl design
- Is available with Lock Down Screws (LDS) in the upper flange for mechanical casing hanger retention
- Has flanges on both the top and bottom of the assembly
- Has a seal area in the bottom flange for a secondary seal between the casing annulus and the flanged connection
- Incorporates a test port in the lower flange to accommodate secondary seal testing.

Bowl	Top Flange	WP	Bottom Flange	WP	Outlet Size	PSL Levels	Material Classes
C-22	11"	3K, 5K, 10K, 15K	11"	3K, 5K, 10K, 15K	2" LPO or Studded	PSL 1 thru 3	AA, EE, FF
C-22	11"	3K, 5K, 10K, 15K	13-5/8"	3K, 5K, 10K, 15K	2" LPO or Studded	PSL 1 thru 3	AA, EE, FF
C-22	13-5/8"	3K, 5K, 10K	16-3/4"	3K, 5K, 10K	2" LPO or Studded	PSL 1 thru 3	AA, EE, FF
C-22	16-3/4"	5K,10K	18-5/8"	5K,10K	2" LPO or Studded	PSL 1 thru 3	AA, EE, FF
C-22	13-5/8"	3K	20-3/4"	3K	2" LPO or Studded	PSL 1 thru 3	AA, EE, FF
C-22	13-5/8"	3K, 5K	21-1/4"	3K, 5K	2" LPO or Studded	PSL 1 thru 3	AA, EE, FF



Casing Spools

Sentry C-29 Casing Spools

The Sentry C-29 casing spool has all of the same features and benefits as the C-22, but is designed for intermediate to extreme casing weights. This head design can also handle the standard C-21 and C-22 casing hangers.

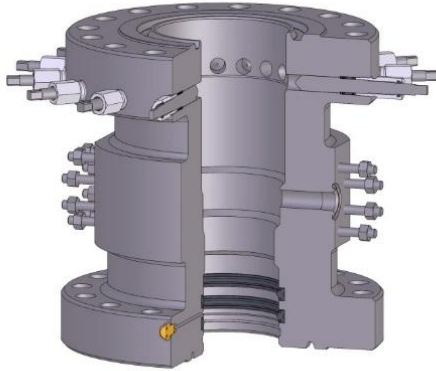

- The C-29 casing spool is designed for intermediate to extreme casing string weights
- It incorporates a straight bowl design
- Is available with Lock Down Screws (LDS) in the upper flange for mechanical casing hanger retention
- Has flanges on both the top and bottom of the assembly
- Has a seal area in the bottom flange for a secondary seal between the casing annulus and the flanged connection
- Incorporates a test port in the lower flange to accommodate secondary seal testing

Bowl	Top Flange	WP	Bottom Flange	WP	Outlet Size	PSL Levels	Material Classes
C-29	11"	3K, 5K, 10K, 15K	11"	3K, 5K, 10K, 15K	2" LPO or Studded	PSL 1 thru 3	AA, EE, FF
C-29	11"	3K, 5K, 10K, 15K	13-5/8"	3K, 5K, 10K, 15K	2" LPO or Studded	PSL 1 thru 3	AA, EE, FF
C-29	13-5/8"	3K, 5K, 10K	16-3/4"	3K, 5K, 10K	2" LPO or Studded	PSL 1 thru 3	AA, EE, FF
C-29	16-3/4"	5K,10K	18-5/8"	5K,10K	2" LPO or Studded	PSL 1 thru 3	AA, EE, FF
C-29	13-5/8"	3K	20-3/4"	3K	2" LPO or Studded	PSL 1 thru 3	AA, EE, FF
C-29	13-5/8"	3K, 5K	21-1/4"	3K, 5K	2" LPO or Studded	PSL 1 thru 3	AA, EE, FF

Casing Spools

C-22 Casing Spool Configurations

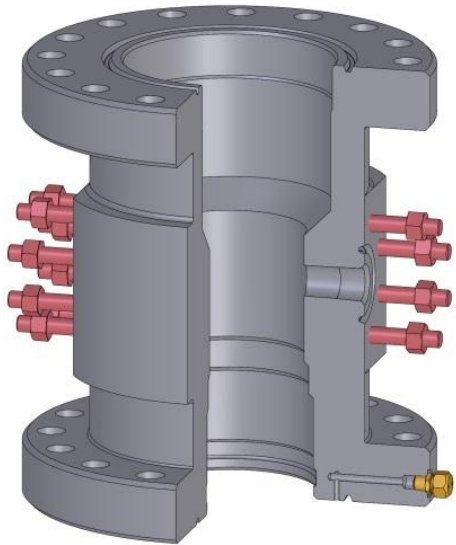

C-22 Flanged Top & Bottom W/Studded Outlets and Blank Lower Secondary Seal Area

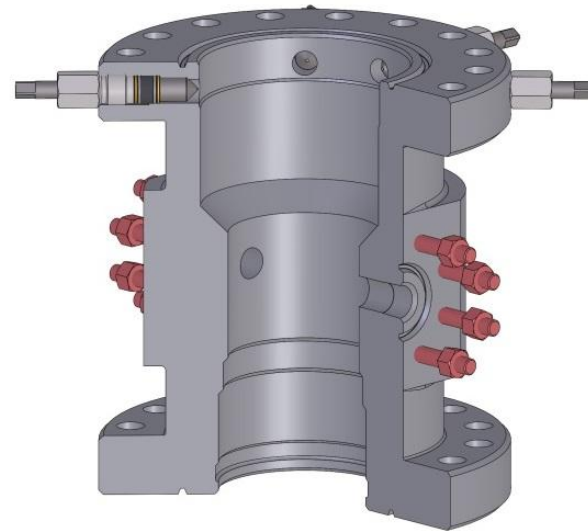

C-22-ET Flanged Top & Bottom W/Studded Outlets and Blank Lower Secondary Seal Area

Casing Spools

C-29 Casing Spool Configurations

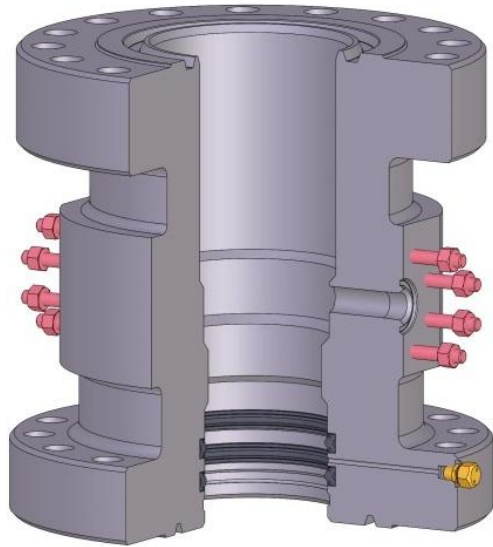

C-29 Flanged Top & Bottom W/Studded Outlets and Double CS Secondary Seal Area

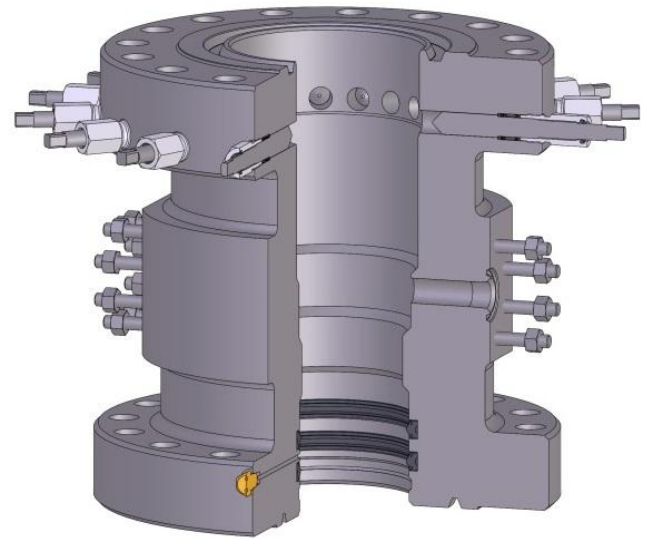

C-29-ET Flanged Top & Bottom W/Studded Outlets and Double CS Secondary Seal Area



Casing Hangers

Casing Hangers

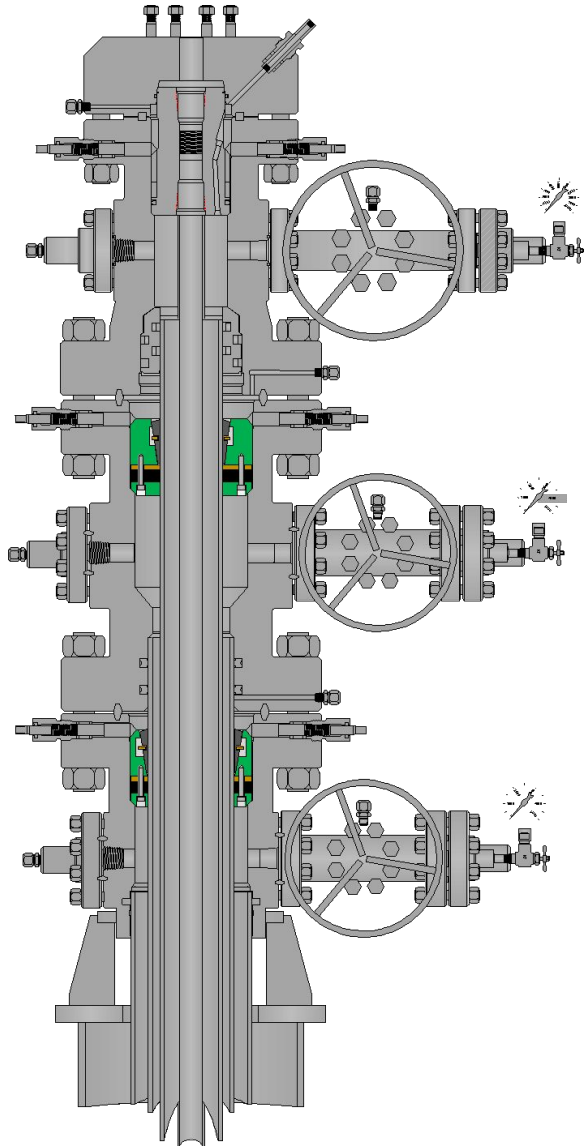

Casing hangers are devices that allow casing to be set in the well bore during the drilling phase of an oil or gas well. There are two basic designs of casing hanger, slip-type or mandrel. The slip-type is the conventional and most commonly used. The mandrel-type is normally used when special needs arise during the building of the well. Both allow for the Tens of Thousands of pounds in weight of the casing string weight to be transferred from the derrick of the drilling rig to the load shoulder in a casing head or spool. A Casing Hanger performs the following functions:

- Suspends the casing load
- Transfers casing weight
- Centers casing
- Provides a primary seal in the casing annulus
- Creates an annular space
- Allows for testing of connections

Casing Hangers

Slip Casing Hanger Components

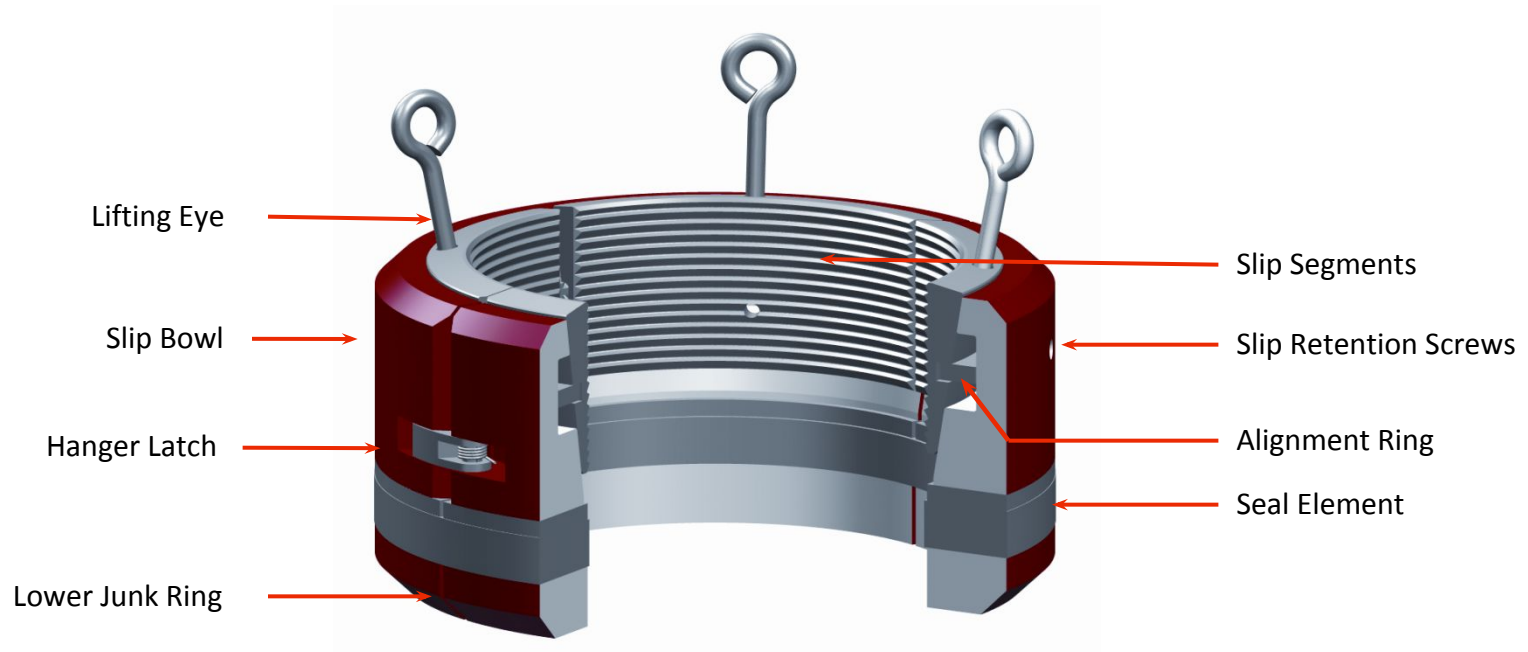

Casing Hangers

Sentry C-21 Casing Hangers

Sentry C-21 casing hangers are the non-automatic solution for hanging casing. The split bowl utilizes the same upper slip segments as the C-22 and C-29 hangers and incorporates a separate seal assembly. This has two benefits. It prevents any well or test pressure from adding to the radial compression of the slip segments. And it is a primary casing seal that can be replaced during workover operations without picking up the pipe.

- Non Automatic casing hangers are typically used when the casing string weight is not sufficient enough to energize the seal mechanism in automatic casing hangers
- The Type-H seal ring utilizes S (OD) and CS (ID) seals to provide the primary seal on the string of casing being suspended in the casing hanger
- The C-21 casing hanger seal mechanism cannot be used if LDS are present in the upper flange of the casing head



Type	Top Flange	Casing Size	WP	PSL Levels	Material Classes
C-21	7"	2 3/8" thru 4-1/2"	3K, 5K, 10K	PSL 1 thru 3	AA, EE, FF
C-21	9"	4-1/2" thru 7"	3K, 5K, 10K	PSL 1 thru 3	AA, EE, FF
C-21	11"	4-1/2" thru 7-5/8"	3K, 5K, 10K	PSL 1 thru 3	AA, EE, FF
C-21	13-5/8"	4-1/2" thru 11-3/4"	3K, 5K	PSL 1 thru 3	AA, EE, FF
C-21	16-3/4"	5-1/2" thru 13-3/8"	3K, 5K	PSL 1 thru 3	AA, EE, FF
C-21	18-5/8"	7" thru 13-3/8"	5K	PSL 1 thru 3	AA, EE, FF
C-21	20-3/4"	9-5/8" thru 16-3/4"	3K	PSL 1 thru 3	AA, EE, FF
C-21	21-1/4"	9-5/8" thru 16-3/4"	3K, 5K	PSL 1 thru 3	AA, EE, FF

Casing Hangers

Sentry C-22 Casing Hangers

Sentry C-22 automatic casing hangers are designed for use with the venerable C-22 casing heads and are an industry standard around the world.

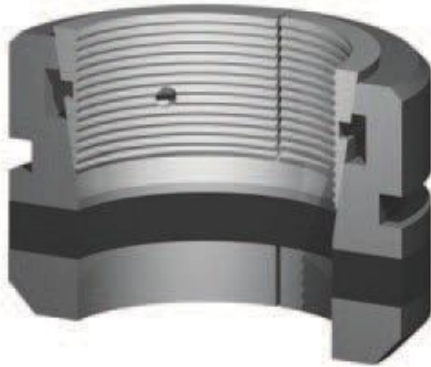

- The C-22 automatic casing hanger has an integral, compression-type seal mechanism that automatically actuates with the weight of the casing string
- The sealing element made into the casing hanger provides the Primary seal on the string of casing being suspended
- The C-22 casing hanger is hinged on one side and latches on the other
- The C-22 casing hanger is designed to be used with the C-22 casing head and is utilized for most intermediate casing string weights
- C-22 Casing Hangers can be utilized in a C-29 casing head or spool

Type	Top Flange	Casing Size	WP	PSL Levels	Material Classes
C-22	7"	2 3/8" thru 4-1/2"	3K, 5K, 10K	PSL 1 thru 3	AA, EE, FF
C-22	9"	4-1/2" thru 7"	3K, 5K, 10K	PSL 1 thru 3	AA, EE, FF
C-22	11"	4-1/2" thru 7-5/8"	3K, 5K, 10K	PSL 1 thru 3	AA, EE, FF
C-22	13-5/8"	4-1/2" thru 11-3/4"	3K, 5K	PSL 1 thru 3	AA, EE, FF
C-22	16-3/4"	5-1/2" thru 13-3/8"	3K, 5K	PSL 1 thru 3	AA, EE, FF
C-22	18-5/8"	7" thru 13-3/8"	5K	PSL 1 thru 3	AA, EE, FF
C-22	20-3/4"	9-5/8" thru 16-3/4"	3K	PSL 1 thru 3	AA, EE, FF
C-22	21-1/4"	9-5/8" thru 16-3/4"	3K, 5K	PSL 1 thru 3	AA, EE, FF



Casing Hangers

Sentry C-29 Casing Hangers

Sentry C-29 casing hangers incorporate a set of 8 independent slip segments. Of these 4 are located above the packing element and 4 below the packing element. These hangers are best suited for extreme casing string weights.

- The C-29 casing hanger is designed to be used with the C-29 Casing head or spool
- The C-29 automatic casing hanger has an integral, compression-type seal mechanism that automatically actuates with the weight of the casing string
- The sealing element made into the casing hanger provides the Primary seal on the string of casing being suspended
- The C-29 casing hanger incorporates many of the same features as the C-22 casing hanger, but is designed for much higher casing string weights

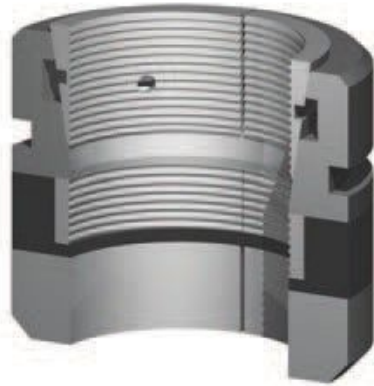

Type	Top Flange	Casing Size	WP	PSL Levels	Material Classes
C-29	9"	4-1/2" thru 7"	3K, 5K, 10K	PSL 1 thru 3	AA, EE, FF
C-29	11"	4-1/2" thru 8-5/8"	3K, 5K, 10K	PSL 1 thru 3	AA, EE, FF
C-29	13-5/8"	5-1/2" thru 11-3/4"	3K, 5K, 10K	PSL 1 thru 3	AA, EE, FF
C-29	16-3/4"	5-1/2" thru 13-3/8"	3K, 5K, 10K	PSL 1 thru 3	AA, EE, FF
C-29	18-5/8"	7" thru 13-3/8"	5K, 10K	PSL 1 thru 3	AA, EE, FF
C-29	20-3/4"	9-5/8" thru 16-3/4"	3K	PSL 1 thru 3	AA, EE, FF
C-29	21-1/4"	9-5/8" thru 16-3/4"	3K, 5K	PSL 1 thru 3	AA, EE, FF



Casing Hangers

Sentry Mandrel Casing Hangers

Sentry Mandrel-type casing hangers are used when special needs arise during the building of the well. They can be customized to meet the needs of your well design in almost any design or configuration. Consult your Sentry Sales Representative to discover how we can help design one to fit your unique requirements.



Fluted Mandrel Hanger



Drilled-Thru Mandrel Hanger

- Mandrel casing hangers can be utilized in conjunction with a pack-off to minimize the time spent setting casing by allowing for the pipe to be set and the annulus sealed without removing the BOP's
- A mandrel casing hanger can be used to secure the well for the safe installation of FRAC equipment by incorporating a back pressure valve profile in the ID
- The mandrel hanger can be utilized to simply prevent any hot work normally performed for the setting of slip-type casing hangers
- A mandrel casing hanger may be designed to meet all three needs mentioned above, in one casing hanger



Secondary Seals

Secondary Seals

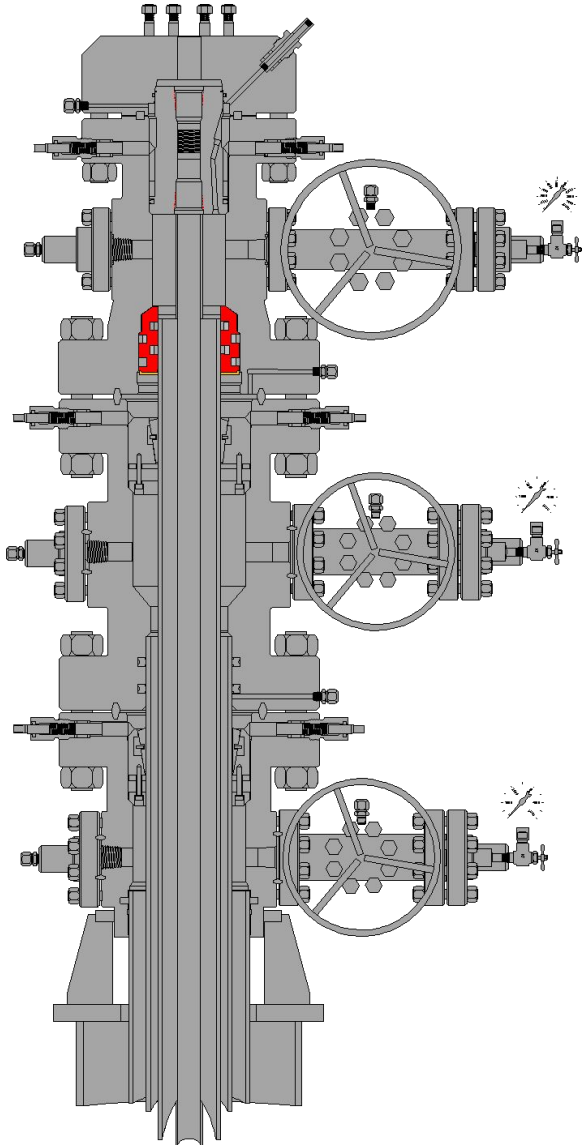

Secondary Seal Assemblies come in many forms and are installed in the lower seal area of the casing spool or tubing head. They are utilized to offer redundant well security between the casing annulus and the flanged connection of a casing head, casing spool or tubing head. In certain instances these seals can offer a special sealing capability for FRAC equipment. Secondary seal assemblies include several advanced elastomeric and metal to metal seal designs.

- Packoffs or Secondary seals come in many different configurations and pressure ratings
- Secondary seals assemblies seal on rough casing
- Some provide an elastomeric seal
- Some provide a metal to metal seal
- Secondary seals, or packoffs, come in many different I.D. sizes allowing for a broad range of casing sizes to be utilized in a standard bottom prep in the casing spool or tubing head

Secondary Seals

Reducer Bushing Components

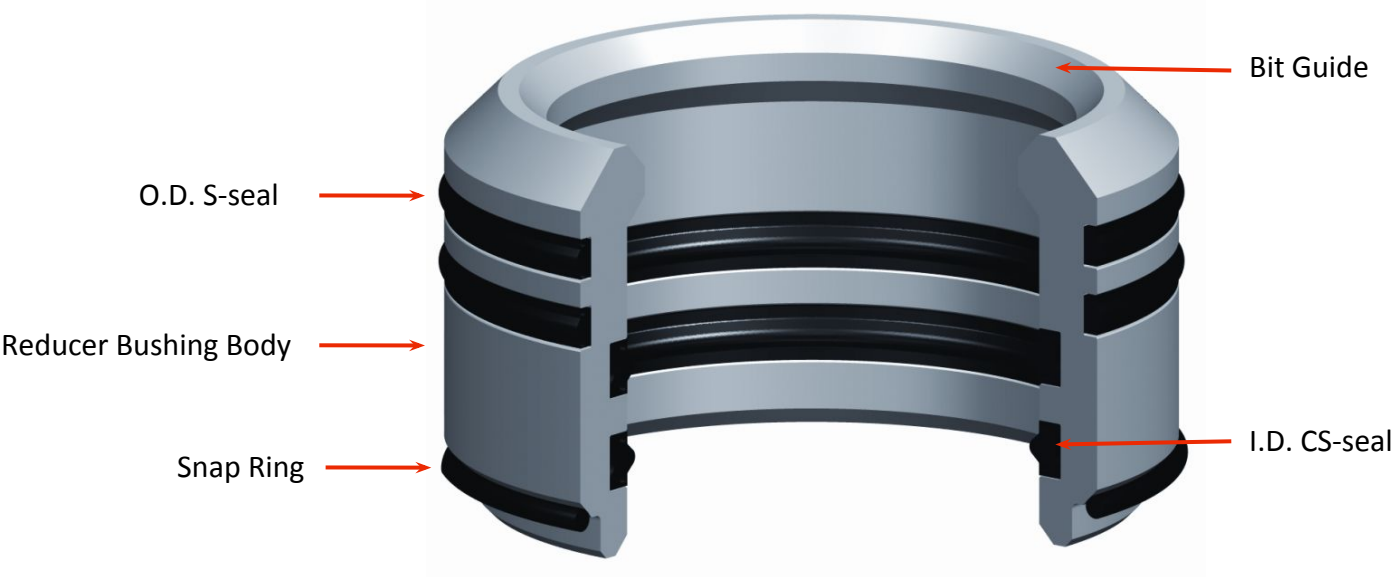

Secondary Seals

Sentry 2-CS Reducer Bushings

The Sentry 2-CS Reducer bushing is the simplest of the secondary seal assemblies. It consists of reducer bushing body, (2) CS Seals in the I.D. of the bushing and a snap ring for retaining the bushing in the secondary seal area of a casing spool or tubing head.



- This design consists of two “CS” seals located in grooves in the I.D. of the reducer bushing body
- A seal is achieved by interference of the seal with the outside diameter of the casing and the I.D. of the seal groove
- A spring molded in each ID corner of the seal provides the anti-extrusion mechanism when sealing against the casing OD
- The shape of the seal allows it flexibility to maintain interference with normal manufactured tolerances of the casing O.D.
- Is utilized in the bottom of a casing spool or tubing head that already has (2) “CS” seals in the secondary seal area

Type	Size	Casing Size	WP	PSL Levels	Material Classes
2-CS	7"	3-1/2" thru 5-1/2"	3K, 5K, 10K	PSL 1 thru 3	AA, EE, FF
2-CS	9"	4-1/2" thru 7-5/8"	3K, 5K, 10K	PSL 1 thru 3	AA, EE, FF
2-CS	9-3/4"	4-1/2" thru 7"	3K, 5K, 10K	PSL 1 thru 3	AA, EE, FF
2-CS	12-1/2"	9-5/8"	3K, 5K, 10K	PSL 1 thru 3	AA, EE, FF



Secondary Seals

Sentry 4S-FS Reducer Bushings

The Sentry 4S-CS Seal Assembly is a secondary seal assembly that features both O.D. and I.D. seals. It consists of reducer bushing body, (2) CS Seals in the I.D. of the bushing accompanied by (2) S-Seals on the O.D. A single snap ring also retains the bushing in the secondary seal area of a casing spool or tubing head.

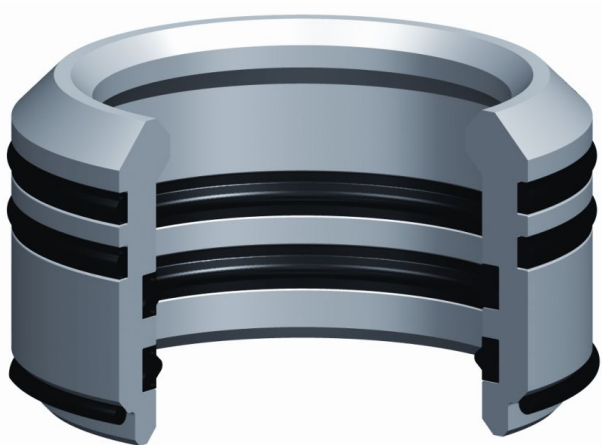

- This design consists of two “CS” seals located in the I.D. of the reducer bushing body and (2) “S” seals located on the O.D.
- A seal is achieved by interference of the seals on both the I.D. and O.D. of the seal assembly
- A spring molded in each ID corner of the seal provides the anti-extrusion mechanism when sealing against the casing OD or the secondary seal area in the casing spool or tubing head
- The shape of the seal allows it flexibility to maintain interference with normal manufactured tolerances of the casing O.D.
- Is utilized in the bottom of a casing spool or tubing head that already has no seals in the secondary seal area

Type	Size	Casing Size	WP	PSL Levels	Material Classes
4S-CS	7"	4-1/2" thru 5-1/2"	3K, 5K, 10K	PSL 1 thru 3	AA, EE, FF
4S-CS	9"	4-1/2" thru 7-5/8"	3K, 5K, 10K	PSL 1 thru 3	AA, EE, FF
4S-CS	9-3/4"	4-1/2" thru 7"	3K, 5K, 10K	PSL 1 thru 3	AA, EE, FF
4S-CS	12-1/2"	9-5/8"	3K, 5K, 10K	PSL 1 thru 3	AA, EE, FF

Secondary Seals

BG-PE Seal Components

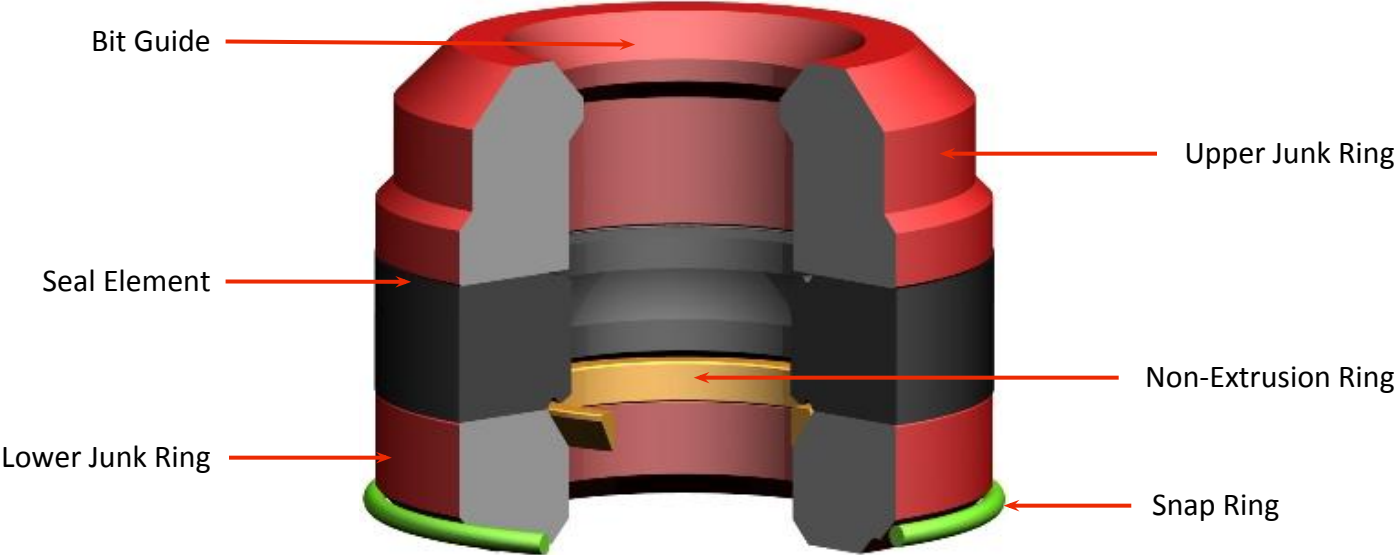

Secondary Seals

Sentry BG-PE Seal Assembly

The BG-PE Seal is a secondary seal of different design. It is a five piece assembly consisting of an upper and lower junk ring, a seal element, a non-extrusion ring and a snap ring to retain the assembly in the secondary seal area of a casing spool or tubing head.

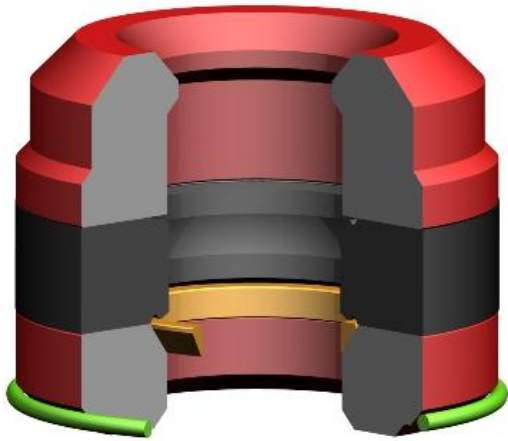

- The upper junk ring serves as a bit guide, (BG)
- In this design the seal element is pressure energized, (PE)
- Utilizes a single molded seal element to affect an annular seal
- Is extremely robust and will still offer a solid, positive seal even if the sealing areas of the element have been damaged and/or sections of the seal element are missing
- Is used in application up to 10,000 PSI

Type	Size	Casing Size	WP	PSL Levels	Material Classes
BG-PE	9"	4-1/2" thru 7-5/8"	3K, 5K, 10K	PSL 1 thru 3	AA, EE, FF
BG-PE	9-3/4"	4-1/2" thru 7-5/8"	3K, 5K, 10K	PSL 1 thru 3	AA, EE, FF
BG-PE	10-3/4"	4-1/2" thru 9-5/8"	3K, 5K, 10K	PSL 1 thru 3	AA, EE, FF
BG-PE	12-1/2"	7" thru 10-3/4"	3K, 5K, 10K	PSL 1 thru 3	AA, EE, FF

Secondary Seals

Sentry Mandrel Hanger Pack-offs



S-CS Seal Pack-off /Support Bushing

This style of secondary seal is designed to be used in conjunction with a mandrel-type casing hanger. They can be installed through the BOP stack over the neck of the mandrel hanger thus sealing off the casing annulus.

Like the mandrel hanger itself, these pack-offs are engineered to meet the unique requirements of your well design.



Tubing Heads

Tubing Heads

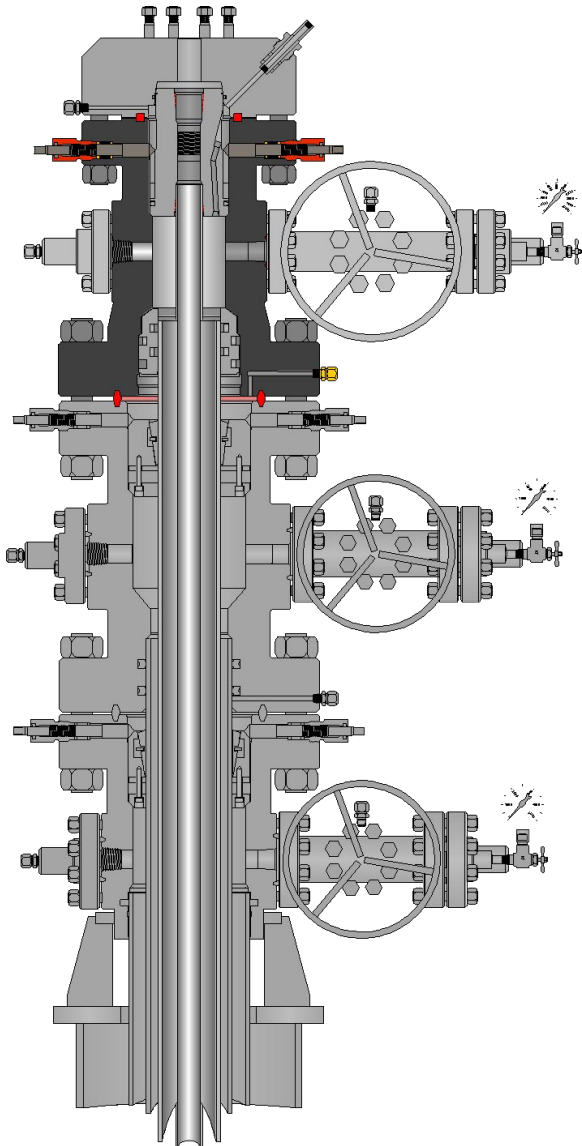

The Tubing Head is the top spool on a surface wellhead. It is typically installed over the last string of pipe suspended in the well, the production casing. These heads come in a wider range of types and sizes than any other head in a conventional wellhead system. The Tubing Head will provide for well fracturing and allow for the well to be completed using an almost innumerable variety of tubing hangers and tubing head adapters.

- Allows for suspending the production tubing in the wellbore.
- Provides a seal bore for the Tubing Hanger
- Incorporates Lock Down Screws to retain the Tubing Hanger and energize its seals in the seal bore
- Supports the blowout preventers (i.e. “BOP’s”) while drilling
- Provides outlets for fluid returns
- Provides a means to test the blowout preventers while drilling
- Has flanges on both the top and bottom of the assembly
- Has a seal area in the bottom flange for a secondary seal between the casing annulus and the flanged connection
- Utilize a test port in the bottom flange that allows for the secondary seal and the flanged connection to be pressure tested

Tubing Heads

Tubing Head Components

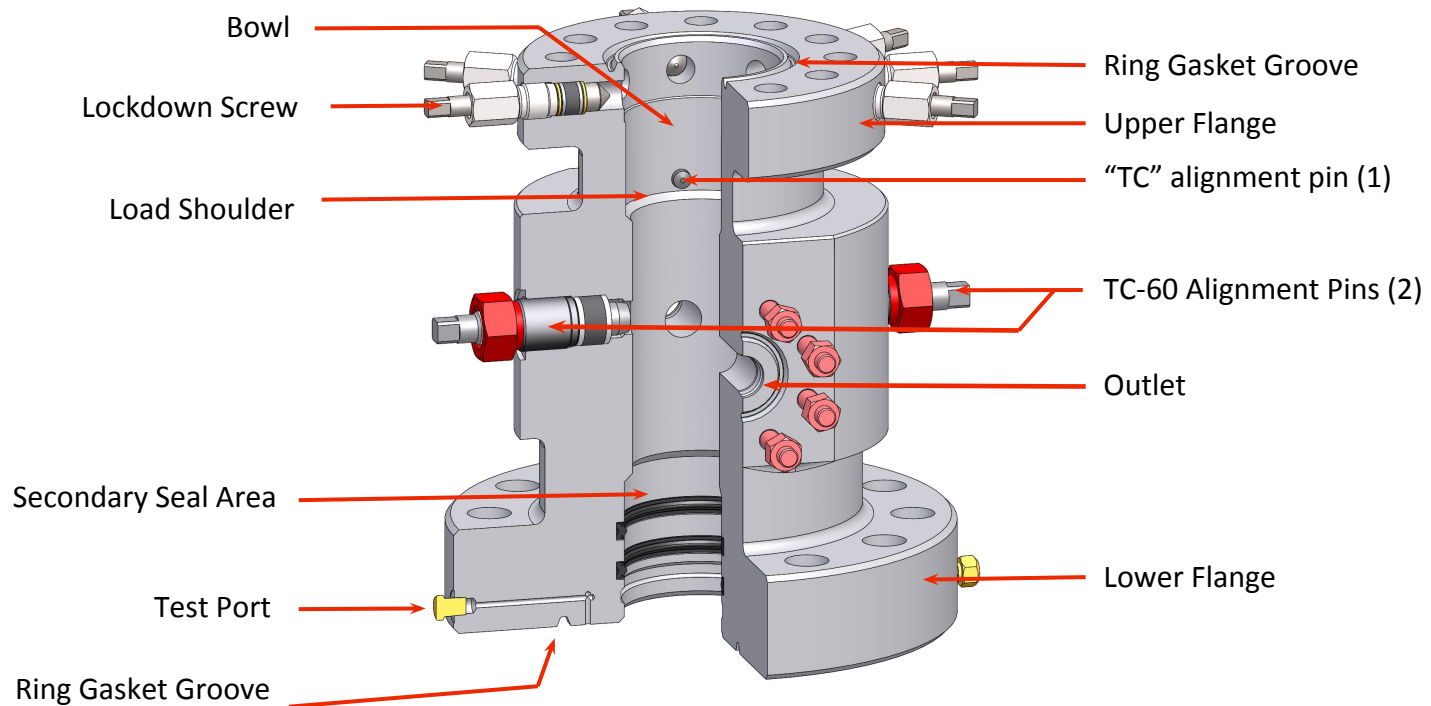

Tubing Heads

Sentry TCM-ET Tubing Heads

The TCM-ET tubing head is one of the most widely used tubing head designs in the wellhead industry. It incorporates a straight bowl design and can accommodate almost any TC tubing hanger that does not require an alignment pin. This includes the TC-1W Wrap-around pack-off used on BO-2 and BO-10 coupling type completions.

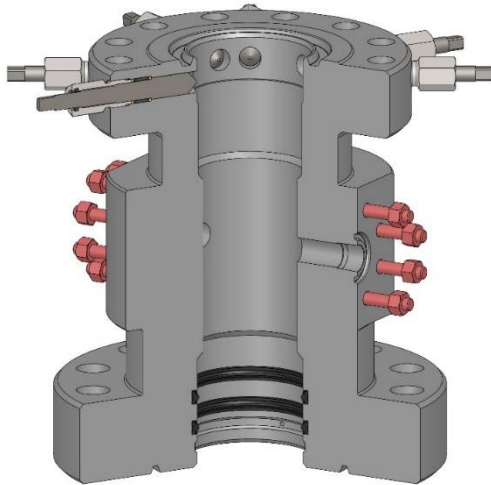

- The TCM-ET tubing head utilizes “ET” style Lock Down Screws (LDS) in the upper flange to retain a tubing hanger or tubing wraparound pack-off
- It does not utilize any alignment pins
- It is available with either threaded or studded outlets
- The TCM-ET tubing head has a secondary seal area in the lower flange
- It has a test port in the lower flange to test the secondary seals and the flanged connection

Bowl	Top Flange	WP	Bottom Flange	WP	Outlet Size	PSL Levels	Material Classes
TCM	7"	3K, 5K, 10K, 15K	11"	3K, 5K, 10K, 15K	2" LPO or Studded	PSL 1 thru 3	AA, EE, FF
TCM	11"	3K, 5K, 10K, 15K	13-5/8"	3K, 5K, 10K, 15K	2" LPO or Studded	PSL 1 thru 3	AA, EE, FF
TCM	13-5/8"	3K, 5K, 10K, 15K	13-5/8"	3K, 5K, 10K, 15K	2" LPO or Studded	PSL 1 thru 3	AA, EE, FF



Tubing Heads

Sentry TC-ET Tubing Heads

The Sentry TC-ET Tubing Head has the same features as the TCM but adds a single alignment pin to the bowl area. This pin provides an orientation point in the head for tubing hangers that have alignment requirements.

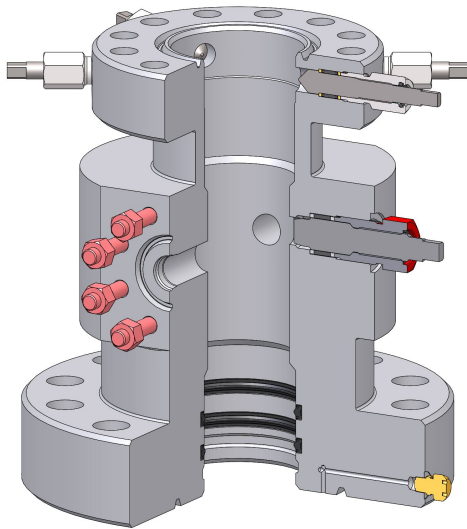

- The TC-ET tubing head incorporates a straight bowl design
- It utilizes Lock Down Screws (LDS) in the upper flange to retain a tubing hanger
- It is flanged top and bottom
- Has outlets for access to the annulus
- The TC-ET Tubing Head has a secondary seal area in the lower flange
- It has a test port in the lower flange to test the secondary seals and the flanged connection

Bowl	Top Flange	WP	Bottom Flange	WP	Outlet Size	PSL Levels	Material Classes
TC-ET	7"	3K, 5K, 10K, 15K	11"	3K, 5K, 10K, 15K	2" LPO or Studded	PSL 1 thru 3	AA, EE, FF
TC-ET	11"	3K, 5K, 10K, 15K	13-5/8"	3K, 5K, 10K, 15K	2" LPO or Studded	PSL 1 thru 3	AA, EE, FF
TC-ET	13-5/8"	3K, 5K, 10K, 15K	13-5/8"	3K, 5K, 10K, 15K	2" LPO or Studded	PSL 1 thru 3	AA, EE, FF



Tubing Heads

Sentry TC-60-ET Tubing Heads

The Sentry TC-60-ET Tubing Head has the same features as the TC but adds two additional alignment pins to the head. These larger alignment pins are located below the bowl area and allow for dual tubing hangers that are split into separate halves, to be run separately, aligned and landed in the bowl of the TC-60-ET tubing head.

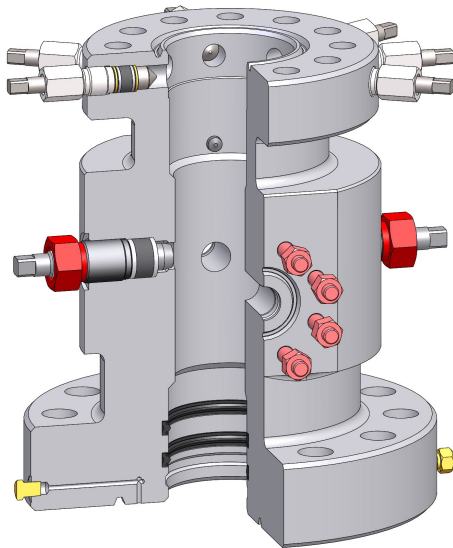

- The TC-60-ET tubing head design can accommodate any TC style tubing hanger
- It utilizes Lock Down Screws (LDS) in the upper flange to retain a tubing hanger
- The TC-60-ET Tubing Head has a secondary seal area in the lower flange
- It has a test port in the lower flange to test the secondary seals and the flanged connection

Bowl	Top Flange	WP	Bottom Flange	WP	Outlet Size	PSL Levels	Material Classes
TC-60-ET	7"	3K, 5K, 10K, 15K	11"	3K, 5K, 10K, 15K	2" LPO or Studded	PSL 1 thru 3	AA, EE, FF
TC-60-ET	11"	3K, 5K, 10K, 15K	13-5/8"	3K, 5K, 10K, 15K	2" LPO or Studded	PSL 1 thru 3	AA, EE, FF
TC-60-ET	13-5/8"	3K, 5K, 10K, 15K	13-5/8"	3K, 5K, 10K, 15K	2" LPO or Studded	PSL 1 thru 3	AA, EE, FF



Tubing Heads

Tubing Head Configurations

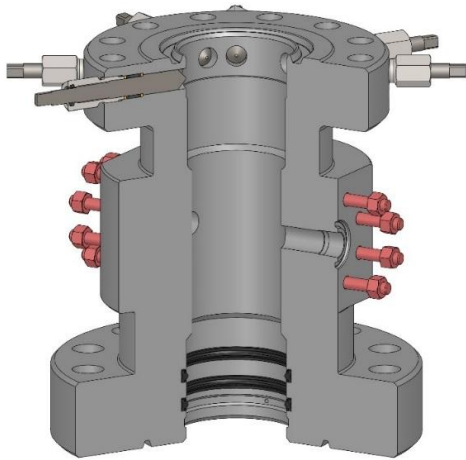

TCM-ET Flanged Top & Bottom
W/Studded Outlets and
Double "CS" Seal Bottom

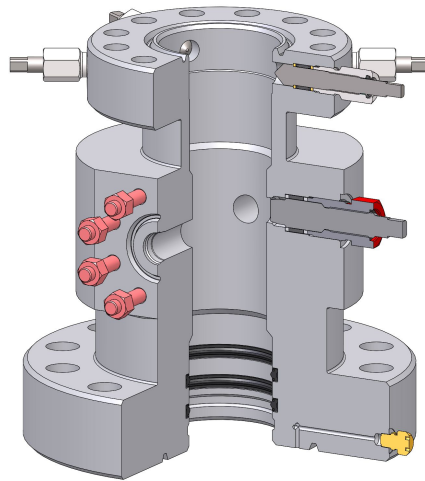

TC-ET Flanged Top & Bottom
W/Studded Outlets and
Double "CS" Seal Bottom

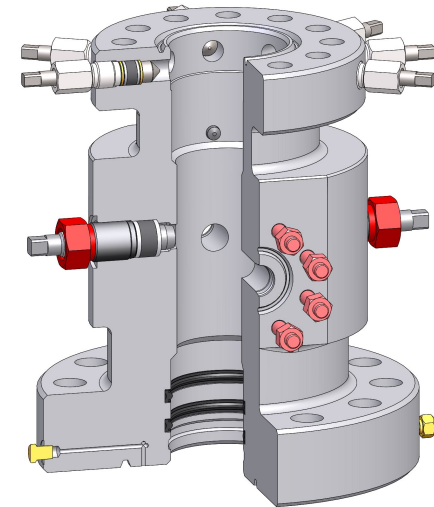

TC-60-ET Flanged Top & Bottom
W/Studded Outlets and
Double "CS" Seal Bottom



Test Plugs & Bowl Protectors

Test Plugs and Bowl Protectors

Bowl Protectors

Bowl Protectors perform the very basic function of protecting the upper bowl sealing areas and load shoulder of a head from the drill bit, drill pipe and downhole tools during drilling or workover operations.

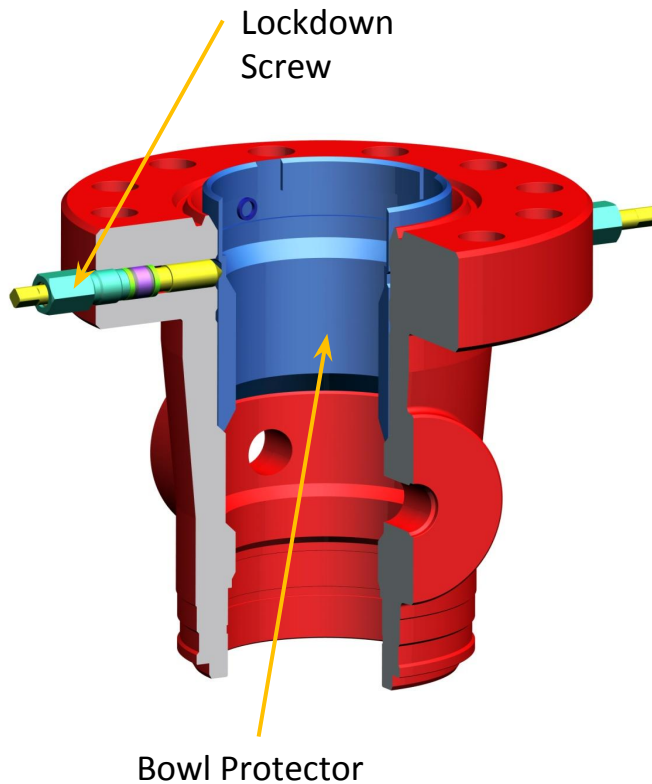

- They are installed in the head by running through the BOP stack using a running tool
- They land on the same load shoulder used by the casing hangers
- The I.D. of the bowl protector needs to allow the drill bit to pass through
- They are normally retained in the head by the Lock Down Screws (LDS) in the upper flange
- Should be pulled regularly to remove any built up mud or sand
- Are inexpensive insurance for protecting the wellhead investment

Test Plugs and Bowl Protectors

Test Plugs

After a casing head or spool and Blow Out Preventers, (BOP), have been installed on a well a pressure integrity test for these items must be conducted. In order for the test to take place, a test plug should be set in the casing head or spool

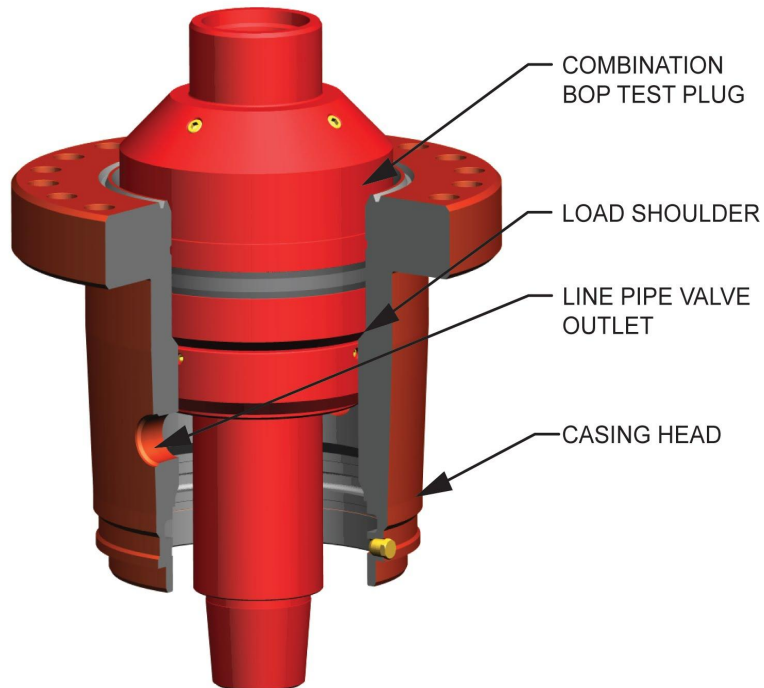

- A BOP test plug can be installed by running it down through the BOP stack and landing it on the load shoulder in the head
- The test plug is usually run on a joint of drill pipe
- Once in place the hydraulic rams of the BOP can be closed on the pipe and a hydrostatic test performed
- This will insure the integrity of the well control equipment prior to the restart of drilling operations



Lockdown Screws

Lockdown Screws

Sentry Lockdown Screws

Sentry lockdown screws, (LDS) utilize an external thread (ET) design that moves the threads outside the pressurized or wetted surface of the wellhead equipment. They utilize a robust Unified National Coarse (UNC) thread for the lockdown screw itself and the packing gland nut to minimize any galling. Additionally a one piece HBNR compression packing element with molded metal end caps to provide a dependable seal in multiple pressure ranges and service environments.

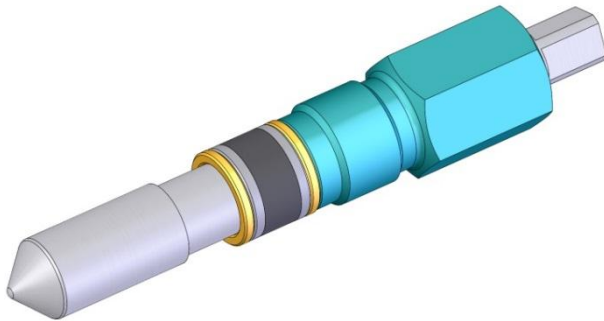

- They mechanically retain items installed in the bowl of a head that are under pressure
- They can be utilized to energize a compression seal or seals installed in the bowl of a head
- They can be used to prevent an item installed in the head from rotating during the drilling phase of a well
- They retain pressure in the flange of a wellhead assembly
- The lockdown screw itself and the packing gland nut are designed with a robust bolt type thread to prevent galling
- They utilize HBNR compression packing with molded metal end caps to provide a dependable seal in multiple pressure ranges and service environments

Lockdown Screws

Lockdown Screw Components

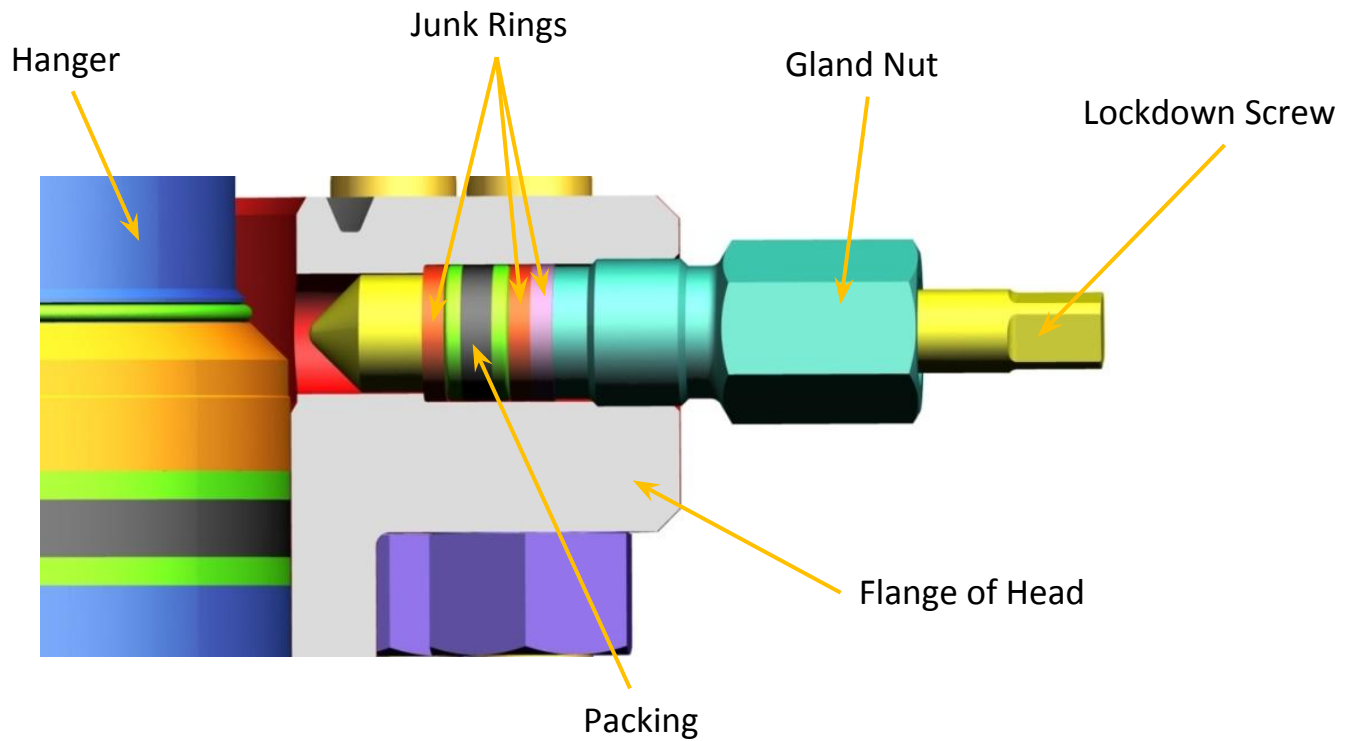

Lockdown Screws

Lockdown Screw Positions

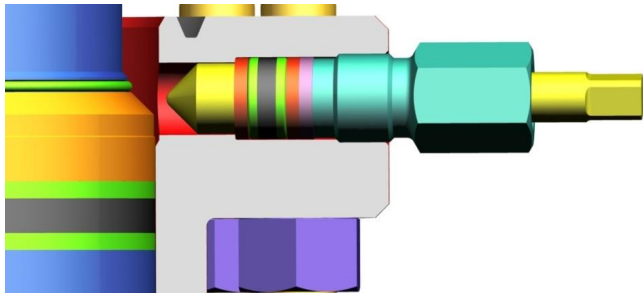

Disengaged

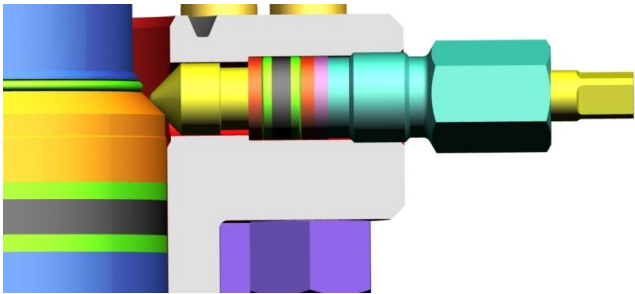

Engaged

Lock Down Screws have the following procedural requirements:

- Are either fully engaged or fully disengaged.
- The lockdown screw gland nut cannot be rotated under pressure
- Must only be operated by fully trained and authorized SWS Field Service Technicians



Seal Technology

Seal Technology

Sentry Wellhead Systems manufactures, and supplies elastomer and metal seals to our customers. Designs are for drilling applications, completion applications and wellhead equipment replacement parts. All seals meet the new stringent design acceptance criteria per API for tolerances.

Oilfield elastomers must be reliable for low-pressure, general service or critical-service wells. We utilize special compounds and designs for situations that require increased service life and efficiencies. Sentry Wellhead Systems has the product to meet your technology needs with the latest solutions for time saving applications.

Elastomer Seals

All Sentry seals meet API Spec. 6A, Appendix F, Performance Requirement Level Two (PR-2) for pressure and temperature cycle testing. Sentry proprietary elastomeric compounds are utilized, rated for all API material classes, including HH which may be used in H2S, or CO2 service; amine resistant. Elements within the seals including anti-extrusion components are continuous. Anti-extrusion devices are integrally molded into the seal element, making them easier to install and more durable. Proper squeeze, volume fill and stretch under all API/Sentry tolerance conditions, (i.e., the largest diametric gap possible and the worst-case misalignment of sealing surface).

Metal Seals

Sentry Wellhead Systems' patented "bump" seal design has addressed many issues traditionally associated with metal seals today, a technological breakthrough for wellhead equipment. Sentry Wellhead Systems' metal seals are rugged enough for oilfield operation, have simple installation procedures, easily tested after installed and are reusable in most cases. In most applications Sentry's metal seals are "self-energizing" and do not rely on a wedging action, suspended weight or flange make-up force to affect a seal.

Sentry metal seals meet API Spec. 6A, Appendix F, Performance Requirement Level Two (PR-2) for pressure and temperature cycle testing and are rated for all API material classes, including HH which may be used in H2S, or CO2 service; amine resistant. Sentry metal to metal seals can be made from almost any high-strength steel or corrosion-resistant alloy and utilized for applications where long life is a requirement (15,000 psi +).



Seal Technology

Sentry S-Seals

This style of seal is the most commonly used in the industry. They utilize continuous coil springs that are scaled to the specific sealing requirement and then integrally bonded to the elastomer during the molding process. This eliminates extrusion gaps and weak points around the circumference of the seal and solves problems associated with explosive decompression damage and chemical swell of the seal during use. "S" seals are designed to be used on all wellhead equipment with machined surfaces up to 15,000 PSI.



I.D. S-seal

- Sentry proprietary elastomeric compounds are utilized on S-seals
- They can be used in H₂S, or CO₂ service and are amine resistant
- Are rated for all API material classes including HH
- Are rated for temperature class L-U (-50° F to 250° F)
- Have been performance qualified for API 6A, PR-2, Appendix F

Seal Technology

Sentry S-Seals

Typical "S" Seal applications are shown below:

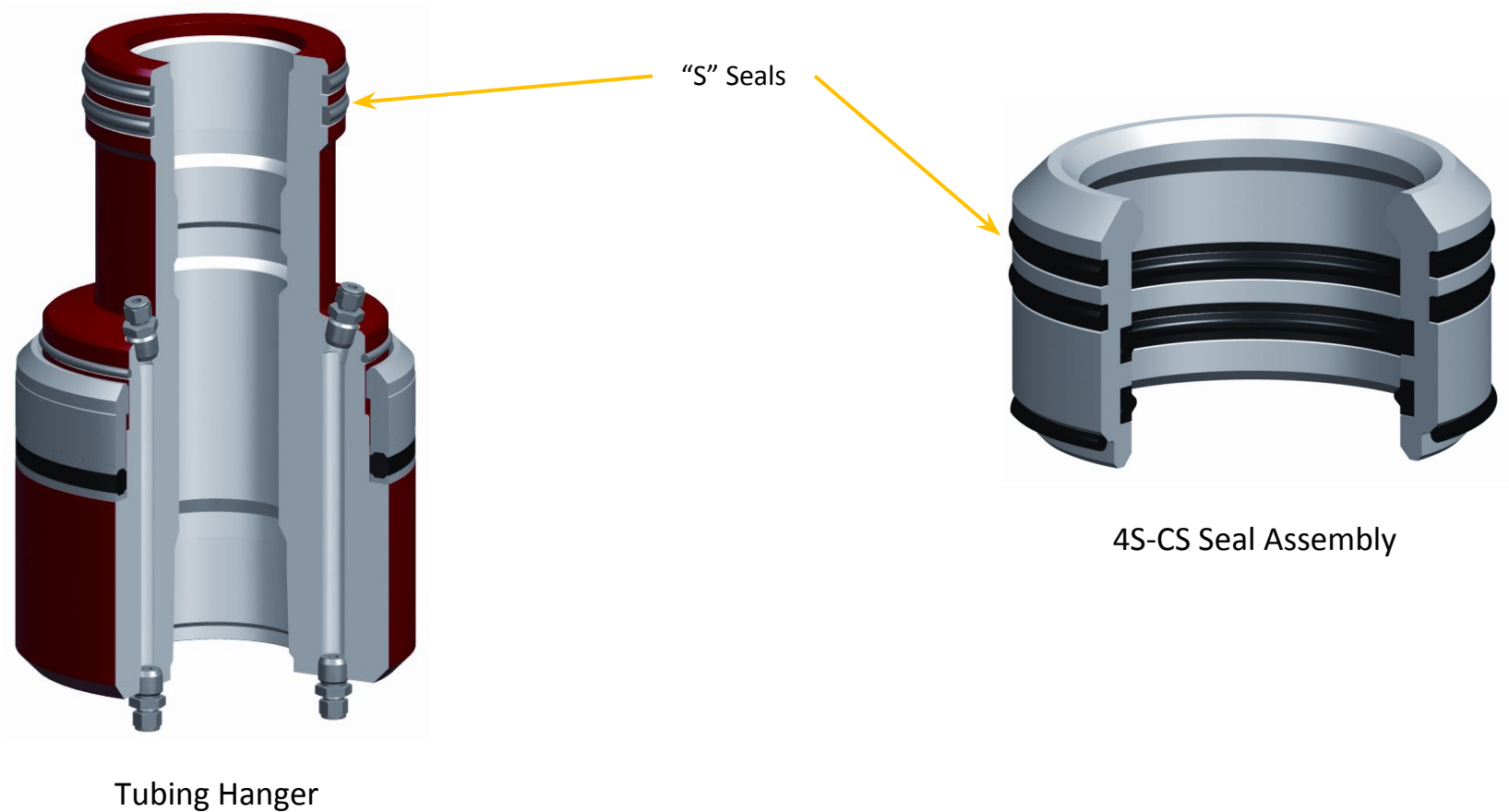

Seal Technology

Sentry CS-Seals

The CS seal is designed to be used on non-machined, rough surfaces such as that found on the O.D. of oilfield casing. They utilize continuously coiled springs that are scaled to the specific sealing requirement and then integrally bonded to the elastomer during the molding process. These seals are capable of providing a seal across a larger range of tolerances and extrusion gaps than the S seal. CS seals are available for all API 5CT casing sizes.

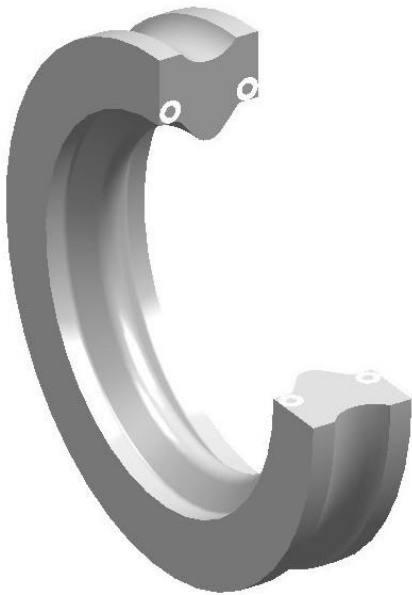

I.D. CS-seal

- Sentry proprietary elastomeric compounds are utilized on CS-seals
- They can be used in H₂S, or CO₂ service and are amine resistant
- Are rated for all API material classes including HH
- Are rated for temperature class L-U (-50° F to 250° F)
- Have been performance qualified for API 6A, PR-2, Appendix F

Seal Technology

Sentry FS-Seals

A typical CS Seal application is shown below:

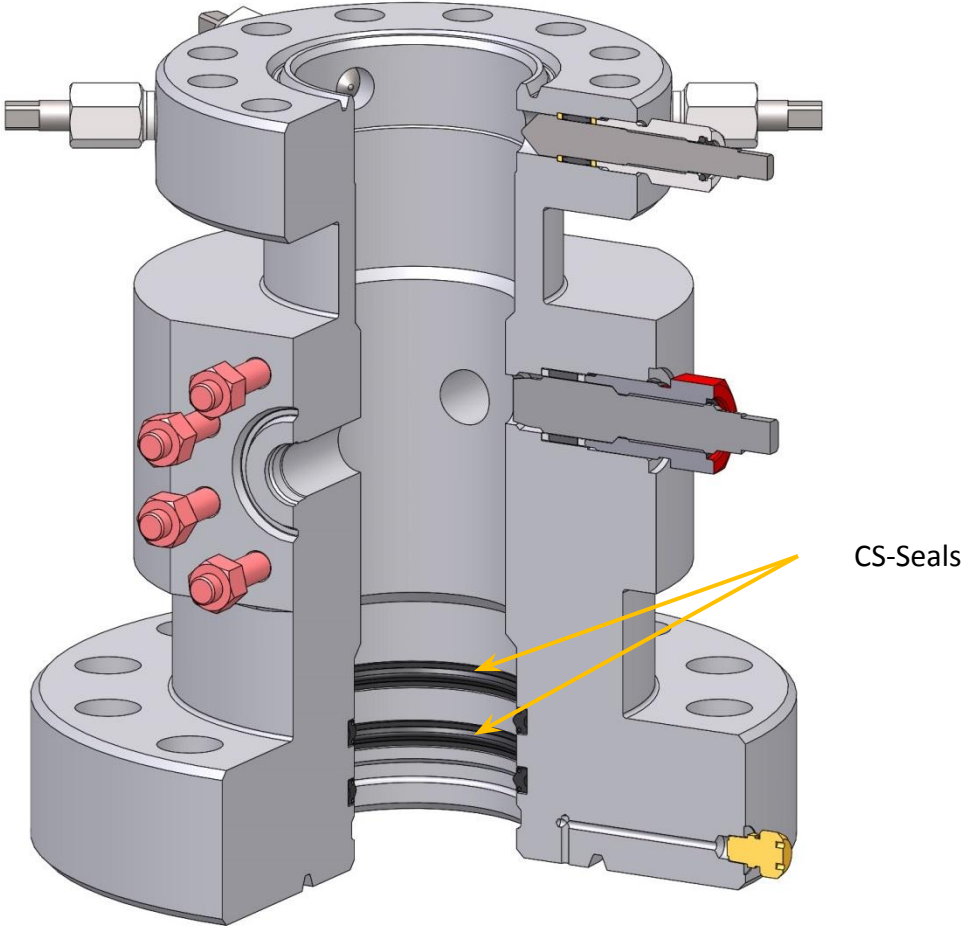

Seal Technology

Sentry Metal Seals

The Sentry Tapered Bore Metal Seal (TBMS) incorporates a rounded “bump” profile to create line contact between the seal and the tapered seal bore. As the flange is tightened the seal is radially compressed to create a gas tight metal to metal seal between the tubing hanger neck the seal itself and the seal bore of the adapter. The radial compression force is constant and allows for the seal to be kept even with large changes in temperature cycling. All of this is accomplished without causing the seal material to reach it’s yield point.



Tapered Bore Metal Seal

- Sentry Tapered Bore Metal Seals are utilized on tubing hangers.
- They can be used in H₂S, or CO₂ service and are amine resistant
- Are rated for all API material classes including HH
- Are rated for temperature class L-U (-50° F to 250° F)
- Have been performance qualified for API 6A, PR-2, Appendix F

Seal Technology

Sentry Tapered Bore Metal Seal

A typical TBMS application is shown below:

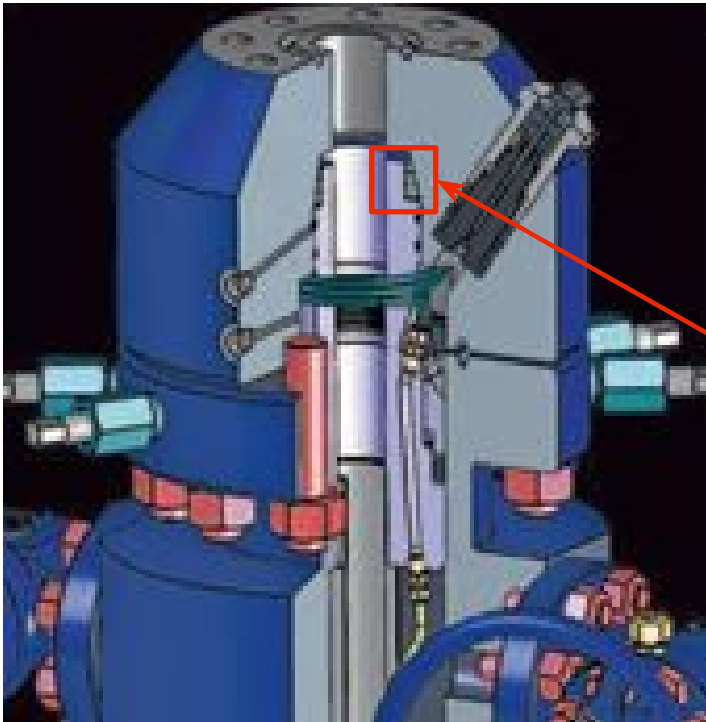

TBMS Seal Interface



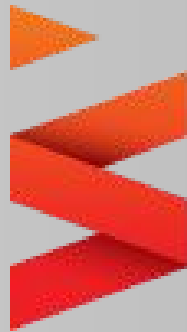

Completion Systems

Completion Systems

HPT Gate Valves

We support some of the best gate valves in the industry for FRAC applications. Available as a manually operated gate valve with the TRMO (Torque Reduction Manual Operator) or as a DAHA (Double Acting Hydraulic Actuator) model operator. The HPT™ Gate Valve product line is available in sizes 2", 3", 4", 5" and 7" and in 5,000, 10,000 and 15,000 PSI working pressures.



- Available with manually operated torque reducers or hydraulic fail-in-position actuators
- Full metal-to metal seal uses no elastomers or O-rings
- Metal-to-metal bonnet seal
- Compatible with most well bore fluids
- Non-rising stem
- High-pressure grease injection fitting located above stem back seat area
- Standard 9/16" autoclave fittings for all 10,000 psi and higher valves
- Forged steel body and bonnet
- Heavy-duty ball bearings
- Bi-directional valve seals on downstream side of gate, regardless of flow direction

Type	Sizes	Connection Type	WP	PSL Levels	Material Classes
HPT	2-1/16" thru 7-1/16"	Studded and Flanged	5K, 10K, 15K	PSL 1 thru 4	AA, DD, EE, FF, HH



Completion Systems

VRC FRAC Heads

Sentry VRC FRAC heads are among some of the most innovative designs in the industry. They are the result of ongoing continuous improvements in FRAC equipment design and are the culmination of experience from thousands of stages pumped moving innumerable barrels of proppant.

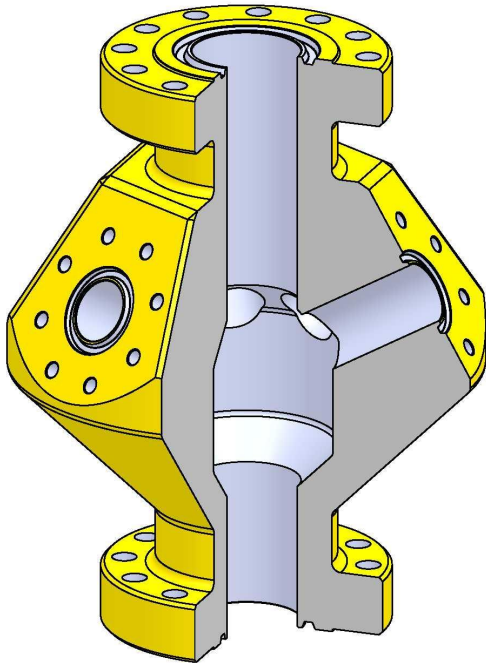

- Sentry FRAC heads utilize VRC (Velocity Reduction Cavity) technology to balance proppant acceleration
- Are available in pressure ranges from 5,000 to 15,000 PSI
- Standardize using API 6A flanges on the run and 4-1/16" API 6A studded inlet connections
- Are available in 2, 4 and 6 inlet configurations
- VRC FRAC heads are available in 30 or 90 degree inlet alignments
- Available with blanking plugs for inactive inlets

Type	Sizes	Run Connection	Outlet Connection	WP	PSL Level	Material Classes
VRC	4-1/16" thru 7-1/16"	Flanged	4-1/16" Studded, 30 or 90 Degree	5K, 10K, 15K	PSL 3	AA, DD, EE, FF



Completion Systems

Modular FRAC Manifolds

Sentry Modular FRAC System designs allow for singular well alignments and multiple additions. They are the solution for value oriented FRAC manifolds and are equipped with the 7-1/16"-10K HPT™ Gate Valve.

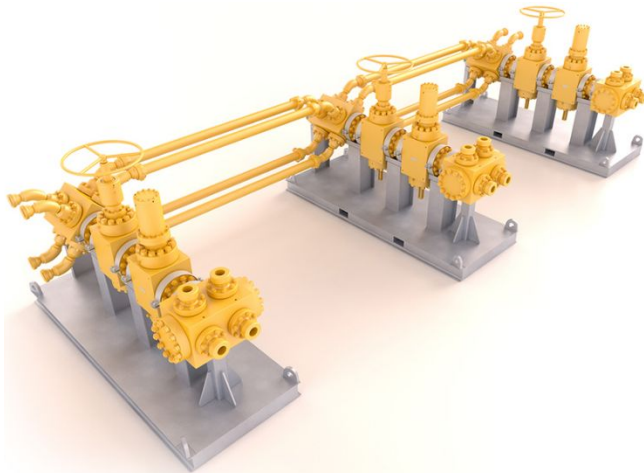

- Are available for 10,000 PSI applications
- Are available in 4, 6 and 8 inlet block configurations
- Utilize the HPT™ 7-1/16"-10K gate valve
- Available with blanking plugs for inactive inlets

Manifold Type	Size	Run Connection	Outlet Connection	WP	PSL Levels	Material Classes
Modular	7-1/16"	Flanged	4-1/16" Studded, 30 or 90 Degree	10K	PSL 1 thru 4	AA, DD, EE, FF



Completion Systems

Engineered FRAC Manifolds

Sentry Engineered FRAC Manifold are designed to meet the specific needs of the customer. They allow for flow rate optimization across the entire scope of the job and have employed unitized block valve/inlet configurations. They can incorporate time saving features for equipment mobilization and de-mobilization. They can be designed for Arctic applications or for use in balancing proppant delivery into multiple well bores. Sentry Engineered FRAC Manifolds were the first in the industry to successfully use elastomeric composite hoses for proppant delivery from the manifold to the FRAC tree. This design was also responsible for stopping the harmonic vibration present in all FRAC jobs, greatly reducing the audible noise associated with this completion technique.



- They allow for flow rate optimization across the entire scope of the job
- Have employed unitized block valve/inlet configurations
- Incorporate time saving features for equipment mobilization and de-mobilization
- Have successfully been designed for Arctic applications
- Used in balancing proppant delivery into multiple well bores
- Sentry Engineered FRAC Manifolds were the first in the industry to successfully use elastomeric composite hoses for proppant delivery incurring no material erosion
- This innovation also ended the harmonic vibration present in all FRAC jobs between the manifold and tree, greatly reducing the audible noise

Manifold Type	Sizes	Inlet and Outlet Connections	WP	PSL Levels	Material Classes
Engineered	4-1/16" thru 7-1/16"	Flanged or Studded Angled or Straight	10K	PSL 1 thru 3	AA, DD, EE, FF



Completion Systems

FRAC Relief Valve Units

Sentry's Fracturing Relief Valve (FRV) is the safest pressure relief system on the market today. Its accuracy, reaction speed, and flow capacity are unparalleled. It increases operational efficiency by providing two valves with every unit, automatic reclose, remote operation from the data van, and the ability to reseal after a relief event on sand. By recording data from all events, engineering can design better products and processes.



- Relief Capacity for a Fluid System at 100 BPM and 12,000 PSI
- Relief Valve Orifice sized according to API 520
- Two Pressure Transducers (0.25% accuracy)
- Digital Pressure Settings up to 20K PSI (non-mechanical)
- Gate Valve (Fail Open) Designed to API 6A with the Sentry Hydraulic Actuator
- Gates & Seats – Tungsten Carbide Hard Faced
- Straight Line Flow (no 90° turns)
- Changing settings and operating the valve takes only seconds, increasing operation efficiency
- All features and trip settings (Open, Reclose, Automatic) can be adjusted to fit the job or well in the field
- Functionality testing requires just a few minutes, and the test data is recorded

Unit Type	Size	Inlet and Outlet Connections	WP	PSL Levels	Material Classes
FRV	1-13/16"	Flanged	10K, 15K	PSL 1 thru 3	AA, DD, EE



Completion Systems

FRAC Accumulator Units

Sentry supports Meyer Services closing units for the operation of our hydraulic FRAC valves. We have worked with Meyer Services for years to develop closing units that meet both our and our customer's needs. These are some of the best closing units in the business. We offer Two and Four station Accumulator Hydraulic Control Units. All Control Units use a five bottle nitrogen cascade system with an air motor back-up. These closing units are designed with service and reliability in mind. Bottles and bladders are easily accessible and serviceable. The modular design allows for future expansion and addition of bottles. If your specifications change we can help you adapt.



Standard Features

- Push button electric drillers panel
- Pneumatic 4-way drillers panel
- Push button pneumatic drillers panel
- PLC Touch Screen

Optional Features

- Electric motor power: explosion proof or industrial
- Diesel powered pumps: both auto start and manual start available
- Air motor powered pump: single and multiple pump configurations
- Remote panel: air, electric push button, PLC touch screen

Unit Type	Sizes	Hose Outlet Connections	WP
FAU	2 and 4 Station	1" NPT	3K

Completion Systems

Test & Torque Units

Sentry's Test and Torque Units for field service are Sentry's design built by Reliable Pumps. These Units feature the Reliable RD 3015 DHT Series triplex pump for operation of the hydro test unit and a DYNEX PF-1002 hydraulic pump powering the hydraulic torque wrenches. Both pumps are serviced by the Perkins 80 HP Diesel power plant. While these test and torque units are normally trailer mounted, they can be constructed on a skid as well. All test and torque units (TTU's) are good for 15,000 PSI pressure testing and 10,000 PSI hydraulic torque wrench operation.

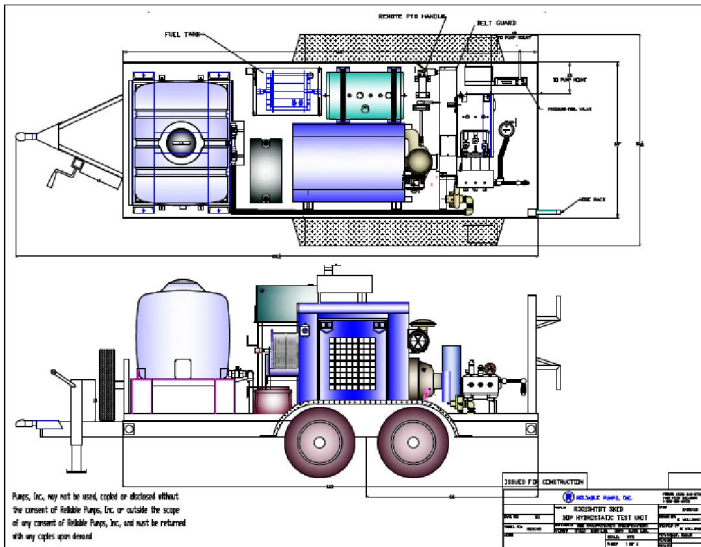

- Perkins 80 HP Diesel power plant
- Model RD30 Series Triplex plunger pump with all stainless steel fluid end assembly producing 7.6 GPM @ 15,000 PSI
- Is equipped with a 200 gallon test fluid tank
- Utilizes a 16,500 PSI relief valve assembly
- Has OSHA approved belt guards
- DYNEX Model PF1002H-10 Hydraulic pump, producing 1.2gpm @ 10,000 PSI
- IS equipped with Spill Containment
- Utilizes the Pressure-Trol Valve hydrostatic test dump valve, lever actuated with pressure gauge, needle valve
- IS equipped with a close proximity PTO lever
- Tandem Axle Trailer 14,000 GVW rated with ICC electric brakes

Unit Type	Pump Type	Maximum Rate	WP	Hose Outlet Connections	Power
TTU	Triplex Plunger	7.6 GPM	15K	1-1/8" Autoclave	Diesel



Completion Systems

FRAC Grease Units

Sentry FRAC Grease units are designed to meet the specific needs of the customer. We utilize the Reliable Model 3575 and incorporate Lincoln Power Master 6" Model 84806 grease pumps service by Kohler 16.8 HP Diesel powered Dual Head Compressors. These compressors provide 35 CFM of free flow@ 175 PSI and are housed in 4-point lift cages with heavy spill containment decks and forklift slots.



- Are equipped with Severe Cold Weather Start Kit
- Dual 120lb drums tray bolted to trailer deck
- 100 ft. Manual Spring Retract 15K Grease Hose reel
- 75ft. Manual Spring Retract Air Hose Reel
- Dual Drum Warmers, Model 4GY13, 115volts, 1000 watts, 8.7 amps, control range 50-400 degrees Fahrenheit, stem rotation 310 degrees, built in electrically grounded screen. Included 6 feet cord with 3 prong molded plug
- Protected by a 4-Point Lift Skid made of 5" channel base with forklift slots and spill containment base. Expanded metal lid on top
- Load Tested and Certified Lift points

Unit Type	Pump Type	Pump Ratio	WP	Hose Outlet Connections	Power
FGU	Air Motor Piston	24:1	15K	9/16" MP Autoclave	Diesel





Production Systems



Tubing Hangers

Tubing Hangers

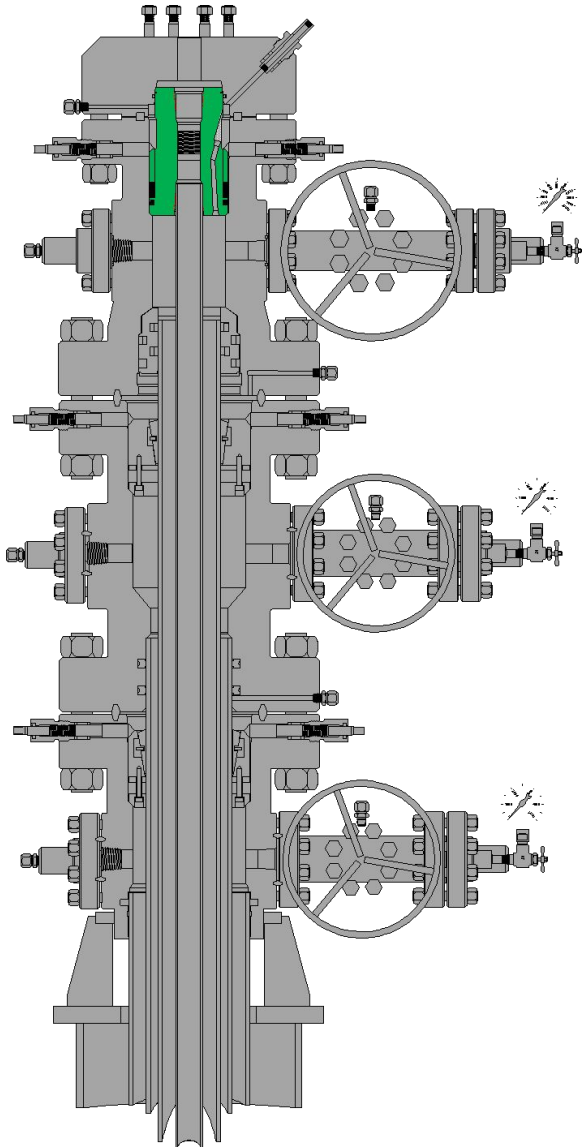

Tubing Hangers are manufactured in a wider variety of types and sizes than any other single component in the wellhead system. They must be configured to meet the needs of a basic completion or the increasingly complex well completion requirements of 21st Century oil and gas wells.

- The Tubing Hanger provides control of the well bore prior to BOP removal
- Suspends the production tubing in the well bore
- Provides the primary annulus seal on the string of tubing being suspended
- Can be manufactured for single or multiple string tubing completions
- Are manufactured with a internal back pressure valve (BPV) profile to seal the ID of the tubing string(s) and provide additional well security prior to BOP removal
- Can be manufactured in configurations including but not limited to, DHCV ports, Chemical Injection ports, Fiber Optic Instrument ports and multiple ESP Penetrator profiles

Tubing Hangers

Tubing Hanger Components

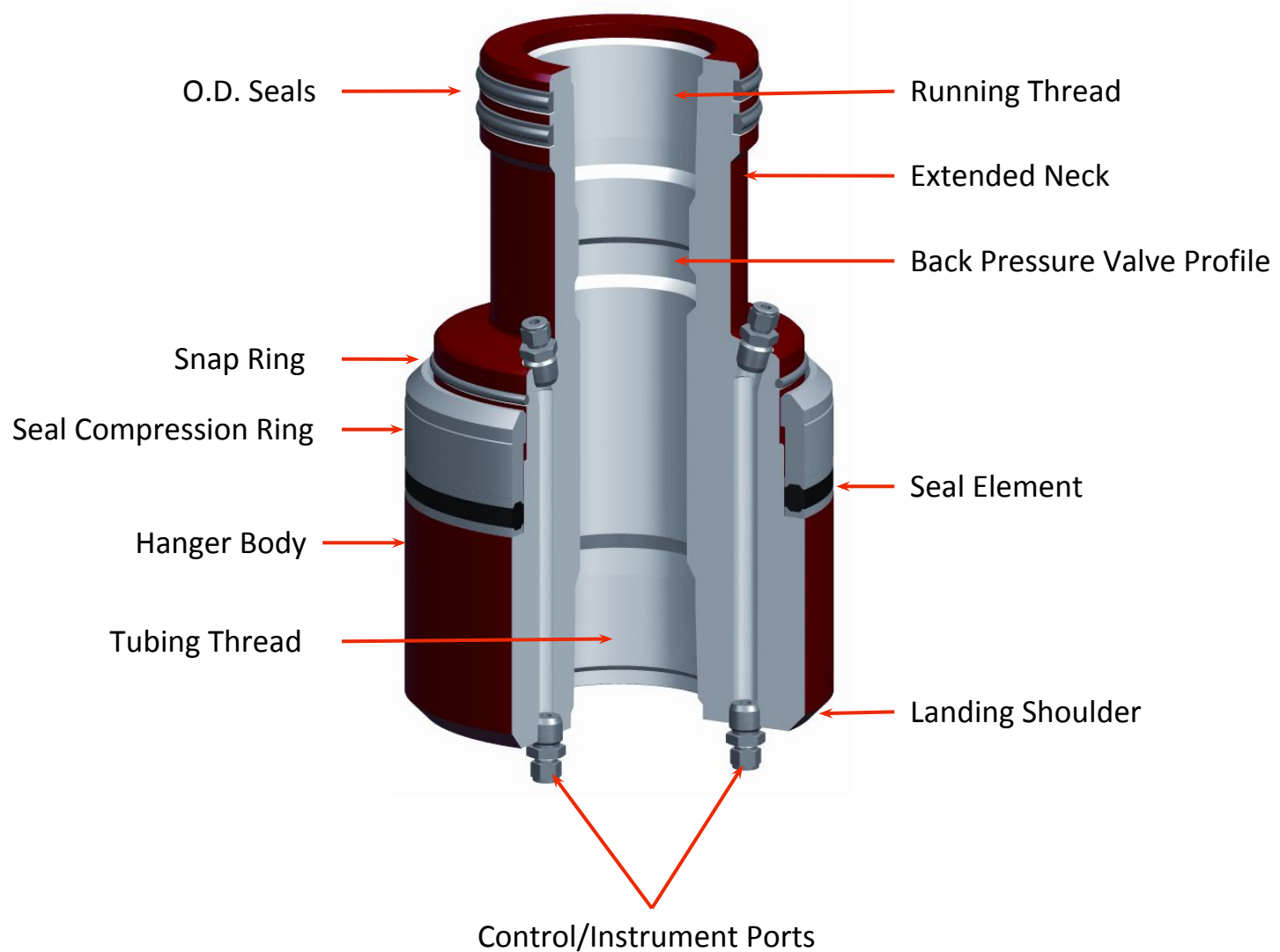

Tubing Hangers

Sentry TC-1A-ENS (Extended Neck Seal) Tubing Hangers

The Sentry TC-1A-ENS tubing hanger is a threaded mandrel type tubing hanger with an extended neck. This hanger utilizes "S" type seals on its neck that are used to seal in the tubing head adapter. This hanger can be configured with interference type "S" seal or compression packing on the body to affect an annular seal. Lock down screws are used to both energize this pack-ing as well as lock the hanger into the tubing head bowl.



- This is a solid mandrel type tubing hanger that can be installed in the top bowl of any TC style tubing head
- Has OD seals on the extended neck
- Does not require alignment in the tubing head
- Can have a compression type or interference type annular seal
- Can contain premium tubing or special landing threads
- Can contain non-continuous porting for control or instrument lines

Type	Bowl Size	Tubing Size	WP	PSL Levels	Material Classes
TC-1A-ENS	7"	2-3/8" thru 3-1/2"	3K, 5K, 10K, 15K	PSL 1 thru 3	AA, DD, EE, FF
TC-1A-ENS	11"	3-1/2" thru 7"	3K, 5K, 10K, 15K	PSL 1 thru 3	AA, DD, EE, FF



Tubing Hangers

Sentry TC-1A-TMS (Tapered Metal Seal) Tubing Hangers

Sentry's TC-1A-TMS tubing hanger is also a threaded mandrel type tubing hanger that is used for more demanding completion applications. The extended neck of the tubing hanger assembly is sealed at the top by the a tapered metal seal (TMS). The TC-1A-TMS also incorporates metal to metal continuous control line fittings that prevent unwanted leak paths in the SCSSSV line. The annular seal can be an externally energized metal seal (XEMS) using lockdown screws to complete the full metal seal capability of the hanger.



- This is a solid mandrel type tubing hanger that can be installed in the top bowl of any TC style tubing head
- Has OD seals on the extended neck for testing
- Does not require alignment in the tubing head
- Can have a compression type or interference type annular seal
- Can have metal to metal XEMS and/or TMS Seals
- Can contain premium tubing or special landing threads
- Can contain special porting for control or instrument lines

Type	Bowl Size	Tubing Size	WP	PSL Levels	Material Classes
TC-1A-TMS	7"	2-3/8" thru 3-1/2"	3K, 5K, 10K, 15K	PSL 1 thru 3	AA, DD, EE, FF
TC-1A-TMS	11"	3-1/2" thru 7"	3K, 5K, 10K, 15K	PSL 1 thru 3	AA, DD, EE, FF

Tubing Hangers

Sentry BO-2 Coupling Tubing Hangers

The Sentry BO-2 coupling type tubing hanger uses a one piece coupling that is externally threaded with a ACME thread. The internal landing and suspension threads match the customer tubing specifications. Additionally the BO-2 coupling incorporates a back pressure valve, (BPV) profile in the I.D. The BO-2 coupling is used with the TC-1W pack-off and is system of choice whenever the tubing string needs to be manipulated to set run in conjunction with a TC-1W wrap around type pack-off.



- This is a coupling type tubing hanger that threads into and suspends the tubing from the bottom of the tubing head adapter
- This tubing hanger is used in conjunction with the TC-1W wraparound pack-off whenever the tubing string needs to be moved up, down or rotated to operate the packer in the bottom of the well and still maintain well security
- Can be supplied with BPV locking groove or thread
- Has Acme load bearing threads
- Incorporates secondary seals in the bottom of BO-2 adapter

Type	Tubing Size	WP	PSL Levels	Material Classes
BO-2	2-3/8" thru 3-1/2"	3K, 5K, 10K	PSL 1 thru 3	AA, DD, EE, FF



Tubing Hangers

Sentry BO-10 Coupling Tubing Hangers

The Sentry BO-10 coupling type tubing hanger shares all of the same design features as the BO-2 AND is generally utilized on completions demanding higher completion shut in pressures. This hanger is a coupling by design but also incorporates a separate rotating, ACME threaded locking nut and is used in conjunction with the TC-1W pack-off.



- The BO-10 coupling is best suited for landing larger trees and any time dissimilar metals may be used for hangers and adapters
- This is a coupling type tubing hanger that suspends the tubing from the bottom of the tubing head adapter
- This tubing hanger is used in conjunction with the TC-1W wraparound pack-off whenever the tubing string needs to be moved up, down or rotated to operate the packer in the bottom of the well and still maintain well security
- Can be supplied with BPV locking groove or thread
- Has Acme load bearing threads

Type	Tubing Size	WP	PSL Levels	Material Classes
BO-10	2-3/8" thru 3-1/2"	3K, 5K, 10K, 15K	PSL 1 thru 3	AA, DD, EE, FF



Tubing Hangers

Sentry TC-1W Wraparound Pack-offs

The TC-1W is a split, wraparound pack-off that allows tubing-string manipulation to displace fluid while maintaining complete control of annular pressure. Like all TC Series pack-offs, tubing string weight must be suspended from a tubing suspension adapter or coupling adapter. The TC-1W has a compression-type seal which is actuated by lockdown screws.



- Considered a primary annulus seal
- The compression seal is actuated utilizing lockdown screws
- Lockdown screws also retain the pack-off in position
- Seats in the TCM, TC and TC-60 tubing head bowl
- Is used in conjunction with a tubing thread suspension adapter, BO-2 or BO-10 coupling type hanger

Type	Bowl Size	Tubing Size	WP	PSL Levels	Material Classes
TC-1W	7"	2-3/8" thru 4-1/2"	3K, 5K, 10K, 15K	PSL 1 thru 3	AA, DD, EE, FF
TC-1W	11"	3-1/2" thru 7"	3K, 5K, 10K, 15K	PSL 1 thru 3	AA, DD, EE, FF



Tubing Hangers

Sentry TC-DC Tubing Hangers

The TC-DC is a dual coupling tubing hanger with a separate master bushing and compression type pack-off. It is utilized for dual completions with lighter tubing loads. The pack-off seal is actuated by lockdown screws. Once the master bushing is set in position, the tubing strings can be run and pulled independently. Each coupling accepts a back pressure valve profile. Due to the utilization of a separate master bushing, the TC-DC is not capable of utilizing down hole control valves or gas lift mandrels.



- The TC-DC is a coupling type dual completion tubing hanger used for light to intermediate weight tubing strings
- It utilizes a master bushing that incorporates compression packing
- It uses couplings that can be landed or pulled together or independently
- Lockdown screws retain the master bushing in position after landing
- It can be used in the TCM tubing head with a rotating flange adapter or the TC Tubing head utilizing a single alignment pin
- It CANNOT accommodate downhole control valves or gas-lift mandrels in the tubing strings

Type	Bowl Size	Tubing Size	WP	PSL Levels	Material Classes
TC-DC	7"	2-3/8" thru 2-7/8"	3K, 5K	PSL 1 thru 3	AA, DD, EE, FF



Tubing Hangers

Sentry TC-60 Tubing Hangers

The TC-60 is a split or segmented tubing hanger with an integral compression type pack-off that is utilized for dual completions with heavier tubing loads. The pack-off seal is actuated by lockdown screws. No plastic injection is required. With the TC-60 tubing strings can be run and pulled independently, allowing maximum clearance for gas lift mandrels or subsurface safety valves. Each segment accepts a back pressure valve and is available with control line preparations for surface controlled subsurface safety valves.



- The TC-60 is a dual split tubing hanger used for intermediate to extreme weight tubing strings
- It utilizes an integral compression type pack-off that is actuated using the tubing head lockdown screws prior to BOP removal
- The split hanger halves can be run and pulled independently
- It can only be used in the TC-60 tubing head utilizing the lower dual alignment pins
- It can accommodate downhole control valves or gas-lift mandrels in the tubing strings and is designed with multiple control line ports for SCSSV's

Type	Bowl Size	Tubing Size	WP	PSL Levels	Material Classes
TC-60	7"	2-3/8" thru 2-7/8"	3K, 5K, 10K, 15K	PSL 1 thru 3	AA, DD, EE, FF
TC-60	11"	2-3/8" thru 3-1/2"	3K, 5K, 10K, 15K	PSL 1 thru 3	AA, DD, EE, FF



Tubing Hangers

Sentry TC-EC Tubing Hangers

The TC-EC tubing hanger is used in conjunction with electrically driven submersible pumps, (ESP's) The hanger is ported, with one port designed to accept a single production tubing string. The second port is designed to accommodate the electrical supply cable that powers the pump. Designs have been completed that also allow for heat trace cabling as well as downhole control valves and/or fiber optic instrumentation lines.

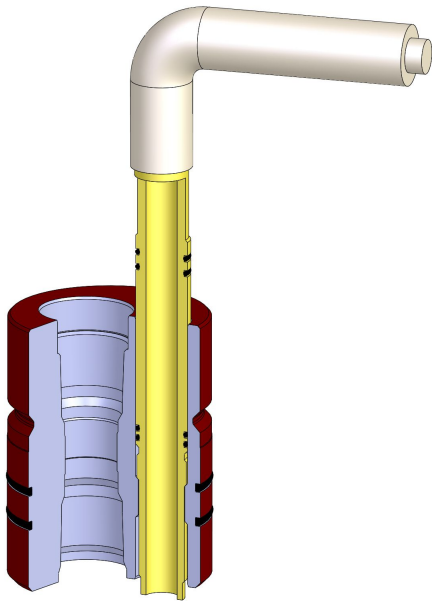

- The TC-EC tubing hanger is designed to be used with electrical submersible pumps
- All components of the TC-EC completion system can be tested to the full rated working pressure of the tubing head and adapter
- The TC-EC electrical designs include Class 1, Div. 1 as well as Class 1A, 1C and 1D
- Have been designed with multiple ports for ESP and Heat Trace Penetrators as well as DHCV and instrumentation lines
- Available in multiple penetrator and pigtail configurations
- The TC-EC tubing hanger can be used in the TCM, TC or TC-60 tubing head
- It can be used with a rotating flange TC-EC adapter

Type	Bowl Size	Tubing Size	WP	PSL Levels	Material Classes
TC-EC	7"	2-3/8" thru 2-7/8"	2K, 3K, 5K	PSL 1 thru 3	AA, DD, EE
TC-EC	11"	2-3/8" thru 4-1/2"	2K, 3K, 5K	PSL 1 thru 3	AA, DD, EE





Tubing Head Adapters

Tubing Head Adapters

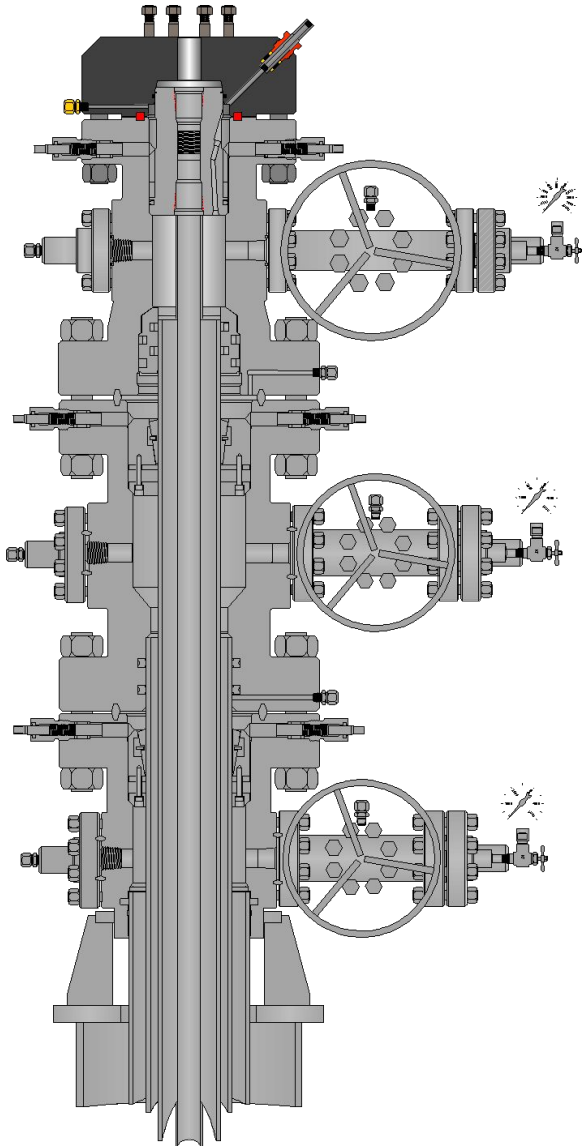

The Tubing Head Adapter is the component that allows for the Christmas tree or other completion equipment to be connected to the tubing head. The designs and types of tubing head adapters are continually evolving in order to meet the new technological needs of the customer's completion requirements. Tubing head adapters:

- Can provide both the primary production tubing seal and the secondary annulus seal on the completion tubing string
- Can be used to actually suspend the weight of the tubing string
- Can be manufactured for single or multiple string tubing completions
- Can be manufactured in configurations including but not limited to, DHCV ports, Chemical Injection ports, Fiber Optic Instrument ports and multiple ESP Penetrator profiles

Tubing Head Adapters

Tubing Head Adapter Components

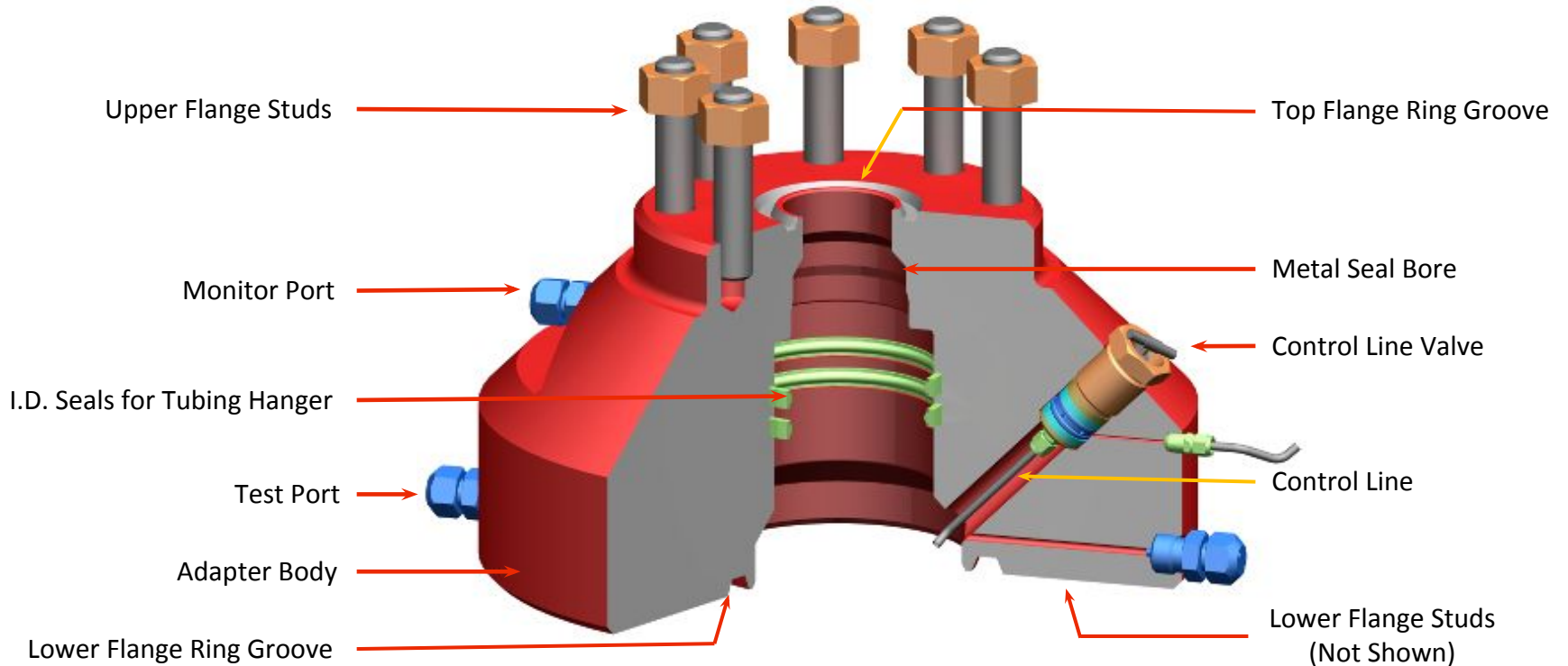

Tubing Head Adapters

Sentry Basic Adapters

Sentry's basic adapters allow for flanges of different sizes and/or pressure ranges to be connected together. They can be manufactured in almost any combination of known API flange sizes and/or API pressure ranges. And can be flanged, studded, clamp hub or a combination of these designs.

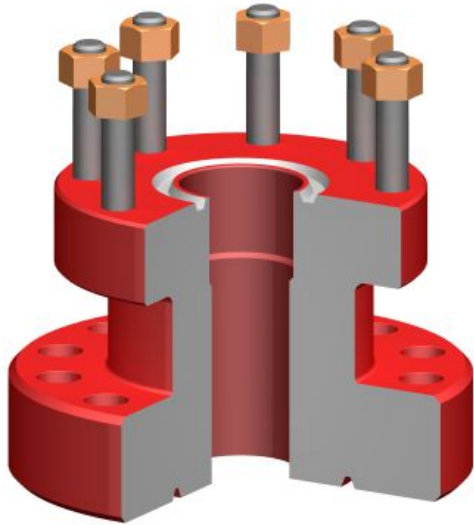

- Are available in innumerable types, and pressure ranges
- Do not have a controlled seal bore
- Do not utilize ports for hydraulic, power supply or instrumentation
- They do not allow for a pipe string to be suspended
- Do not accommodate multiple tubing strings

Type	Upper Connection Size	Lower Connection Size	WP	PSL Levels	Material Classes
All	All API Sizes	All API Sizes	2K, 3K, 5K, 10K, 15K, 20K	PSL 1 thru 3	All



Tubing Head Adapters

Sentry B-1 Tubing Head Adapters

Sentry's B-1 adapters can hang tubing utilizing tubing threads machined into the bottom ID of the flange. These are employed when an operator wants to reciprocate tubing as part of the completion process. Additionally they can be used as a non-suspension adapter when employed with the TC-1A or TC-1A-BP tubing hangers. They are used with threaded valves in low pressure applications.

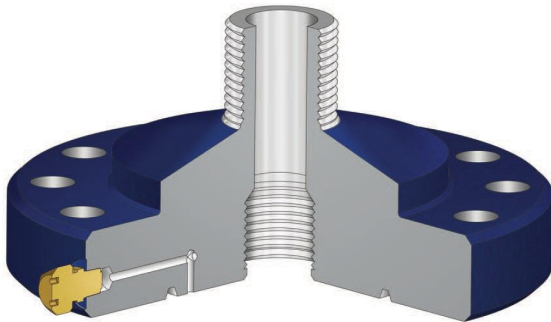

- Are normally used in conjunction with the TC-1W wrap-around or TC stripper pack-off
- Are for use with threaded valves
- Can be utilized with the TC-1A, or TC-1A-BP tubing hanger and seal sleeve
- Are equipped with a test port for testing the flanged connection utilizing the TC-1A or TC-1A-BP tubing hanger and seal sleeve
- They cannot be used for multiple tubing string completions
- Cannot accommodate ports for hydraulic, power supply or instrumentation

Type	Flange Size	Tubing Size	WP	PSL Levels	Material Classes
B-1	7"	2-3/8" thru 3-1/2"	2K, 3K, 5K	PSL 1 thru 3	AA, DD, EE



Tubing Head Adapters

Sentry B-2-P Tubing Head Adapters

Sentry's B-2-P adapters can also suspend tubing utilizing threads machined into the bottom ID of the flange. They are employed when an operator wants to reciprocate tubing as part of the completion process, or can be utilized as a non-suspension adapter when used with the TC-1A or TC-1A-BP tubing hanger. They are used with flanged gate valves in low to medium shut-in pressure applications.

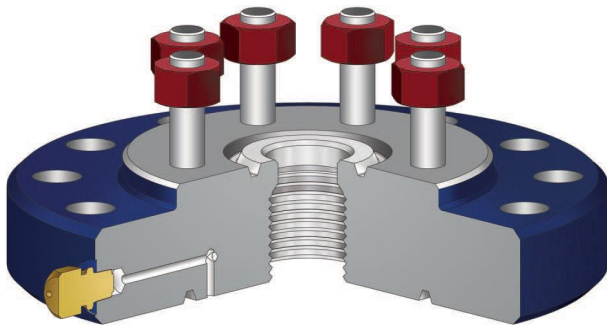

- Are normally used in conjunction with the TC-1W wrap-around or TC stripper pack-off
- Are for use with flanged valves
- Can be utilized with the TC-1A, or TC-1A-BP tubing hanger and seal sleeve
- Are equipped with a test port for testing the flanged connection utilizing the TC-1A or TC-1A-BP tubing hanger and seal sleeve
- They cannot be used for multiple tubing string completions
- Cannot accommodate ports for hydraulic, power supply or instrumentation

Type	Bottom Flange Size	Tubing Size	Top Flange Size	WP	PSL Levels	Material Classes
B-2-P	7"	2-3/8" thru 3-1/2" EUE	2-1/16" thru 3-1/8"	2K, 3K, 5K	PSL 1 thru 3	AA, DD, EE



Tubing Head Adapters

Sentry BO-2 Adapters

Sentry's BO-2 adapter is another example of a suspension adapter. It is designed with an internal ACME thread that allows for the Sentry BO-2 coupling to be threaded in the bottom of the adapter and sealed with an internal O-ring. These adapters also employ the TC-1W wrap-around pack-off. They are employed when an operator wants to reciprocate tubing as part of the completion process.

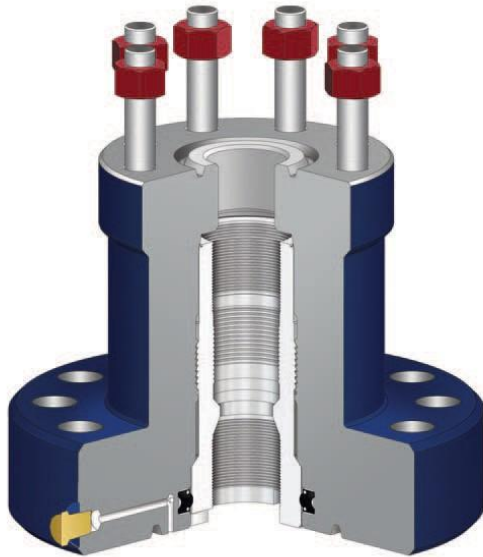

- Is utilized for medium to high shut pressure applications
- Is designed with an internal O-ring seal
- Is supplied with test ports for testing
- They do not allow for multiple tubing string completions
- Are not used for severe service completions

Type	Bottom Flange Size	Tubing Size	Top Flange Size	WP	PSL Levels	Material Classes
BO-2	7"	2-3/8" thru 3-1/2" EUE	2-1/16" thru 3-1/8"	2K, 3K, 5K, 10K	PSL 1 thru 3	AA, DD, EE
BO-2	11"	4-1/2" EUE	4-1/16"	5K, 10K	PSL 1 thru 3	AA, DD, EE



Tubing Head Adapters

Sentry BO-10 Adapters

Sentry's BO-10 adapter is the solution for extreme tubing string weight applications for a coupling type adapter. This adapter is designed with an ACME load nut for larger trees. This allows for the tree to be made up without rotating the tree and prevents any thread galling that may occur between dissimilar NACE coupling and adapter materials. Additionally, it incorporates internal "S" seals on the upper extended neck. Like the BO-2 these adapters also employ the TC-1W wrap-around pack-off. This system is employed when an operator wants to reciprocate tubing as part of the completion process.

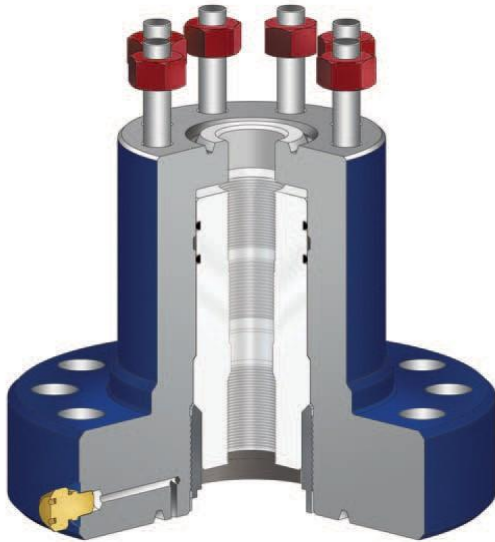

- Is utilized for critical high shut pressure applications
- Is designed with the internal S-seal good to 15K
- Is supplied with test ports for testing
- They do not allow for multiple tubing string completions

Type	Bottom Flange Size	Tubing Size	Top Flange Size	WP	PSL Levels	Material Classes
BO-10	7"	2-3/8" thru 3-1/2" EUE	2-1/16" thru 3-1/8"	10K and 15K	PSL 1 thru 3	AA, DD, EE, FF



Tubing Head Adapters

Sentry A-5-P Adapters

Sentry's A-5-P adapter is an economical choice for a seal bore adapter. This assembly has a flanged bottom allowing it to connect directly to a tubing head with a studded top connection. This adapter is best suited for medium to high pressure shut in well pressure applications and is available in larger flange sizes.



- This adapter has a flanged bottom and studded top
- Is available with non-continuous DHCV or Chemical Injection line ports
- Is available in larger flange sizes
- Is an economical choice for medium (5K) to high pressure (10K) completions

Type	Bottom Flange Size	Top Flange Size	WP	PSL Levels	Material Classes
A-5-P	7-1/16"	2-1/16" thru 4-1/16"	2K, 3K, 5K, 10K	PSL 1 thru 3	AA, DD, EE
A-5-P	11"	3-1/16" thru 5-1/16"	5K, 10K	PSL 1 thru 3	AA, DD, EE
A-5-P	13-5/8"	4-1/16" thru 7-1/16"	5K, 10K	PSL 1 thru 3	AA, DD, EE



Tubing Head Adapters

Sentry A-4 Adapters

Sentry's A-4 adapter is one of the more versatile designs for a seal bore tubing head adapter. It can contain more features than any other design. It allows for elastomeric, metal to metal or a combination of the two seal types to be employed. It can have non-continuous or continuous control lines, in multiple quantities if needed. And these control line, injection or other type ports can be the lockdown screw type, flanged or customized to meet your needs.

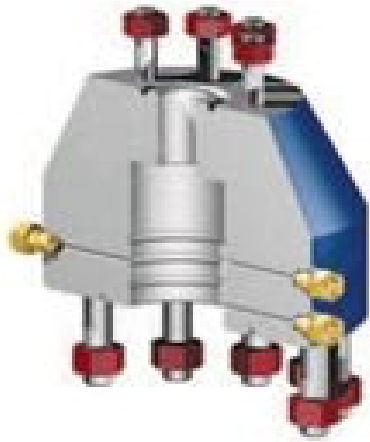

- These adapters are studded top and bottom
- Can have non-continuous or continuous control line ports
- Can have multiple control line ports
- Can include high pressure completions (15K)
- Is available in several NACE corrosive resistant materials

Type	Bottom Flange Size	Top Flange Size	WP	PSL Levels	Material Classes
A-4	7-1/16"	2-1/16" thru 4-1/16"	2K, 3K, 5K, 10K	PSL 1 thru 3	AA, DD, EE, FF
A-4	11"	3-1/16" thru 5-1/16"	5K, 10K	PSL 1 thru 3	AA, DD, EE, FF
A-4	13-5/8"	4-1/16" thru 7-1/16"	5K, 10K	PSL 1 thru 3	AA, DD, EE, FF



Tubing Head Adapters

Sentry A-4-TMS Adapters

Sentry's top of the line A-4-TMS adapter offers our Tapered Metal Seal, (TMS) and Continuous Control Lines, (CCL) for critical severe service applications. It can utilize multiple CCL ports for downhole control valves (DHCV), instrumentation, chemical injection and fiber optic needs. This adapter is available in all API 6A PSL levels, trim classes and temperature ratings.



- Has studded connections top & bottom
- Fully utilizes metal to metal sealing technology for the production bore and all porting
- Is available in all API 6A PSL levels, trim classes and temperature ratings
- Meets all PR2 testing requirements
- Is well adapted for all high pressure, severe service applications

Type	Bottom Flange Size	Top Flange Size	WP	PSL Levels	Material Classes
A-4	7-1/16"	2-1/16" thru 4-1/16"	5K, 10K, 15K	PSL 1 thru 4	AA, DD, EE, FF, HH
A-4	11"	3-1/16" thru 5-1/16"	5K, 10K, 15K	PSL 1 thru 4	AA, DD, EE, FF, HH
A-4	13-5/8"	4-1/16" thru 7-1/16"	5K, 10K	PSL 1 thru 4	AA, DD, EE, FF, HH



Tubing Head Adapters

Sentry A3-EC Adapters

The Sentry A3-EC tubing head adapter is for use with the TC-EC tubing hanger. When utilized together they create an effective tool for enhanced oil recovery (EOR) projects and are available in multiple electrical penetrator configurations. These adapters are fully testable to the rated working pressure of the wellhead equipment.

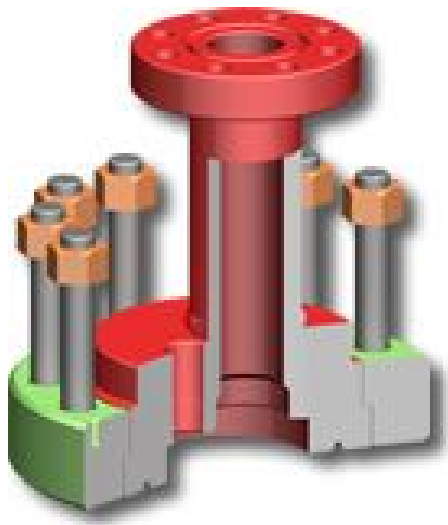

- Can be utilized with an alignment pin tubing head if desired to properly align the production wing and penetrator bore with the wellsite
- When utilized with a tubing head that does not have an alignment pin these adapters can have rotating flanges on both the top and bottom connections to align the production wing
- Can also have multiple DHCV, instrumentation, injection or fiber optic ports

Type	Bottom Flange Size	Top Flange Size	WP	PSL Levels	Material Classes
A-4	7-1/16"	2-1/16" thru 3-1/8"	3K, 5K	PSL 1 thru 3	AA, DD, EE
A-4	11"	3-1/8" and 4-1/8"	3K, 5K	PSL 1 thru 3	AA, DD, EE



Tubing Head Adapters

Sentry A-4-D Adapters

The A-4-D is suited for medium to high shut in pressure dual completion strings. This adapter is studded top and bottom and is utilized in conjunction with the TC-60 dual split tubing hanger and the TC-60-ET tubing head. This system is normally employed for high pressure and/or critical service applications and is available in multiple completion configurations

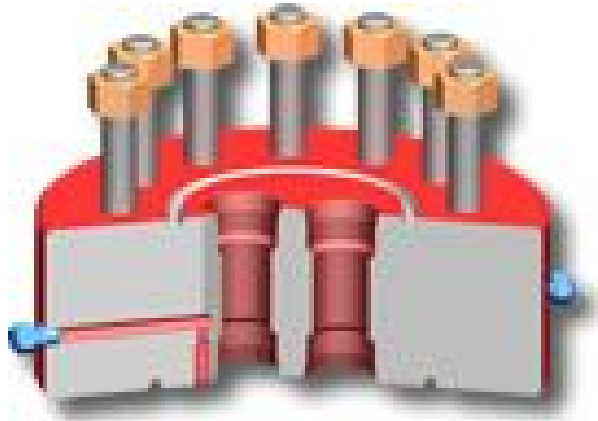

- The A-4-D is utilized for higher pressure and/or critical service applications
- Can have multiple control, instrumentation, injection or fiber optic ports
- All ports are available in either non-continuous or as continuous control lines (CCL)
- Is available with the tapered metal seal (TMS) on the production bore seal sleeves

Type	Bottom Flange Size	Top Flange Size	WP	PSL Levels	Material Classes
A-4	7-1/16"	2-1/16" thru 2-9/16"	5K, 10K, 15K	PSL 1 thru 3	AA, DD, EE, FF, ,HH
A-4	11"	3-1/8" thru 4-1/16"	5K, 10K, 15K	PSL 1 thru 3	AA, DD, EE, FF, HH





Production Trees

Production Trees

Production Tree Components

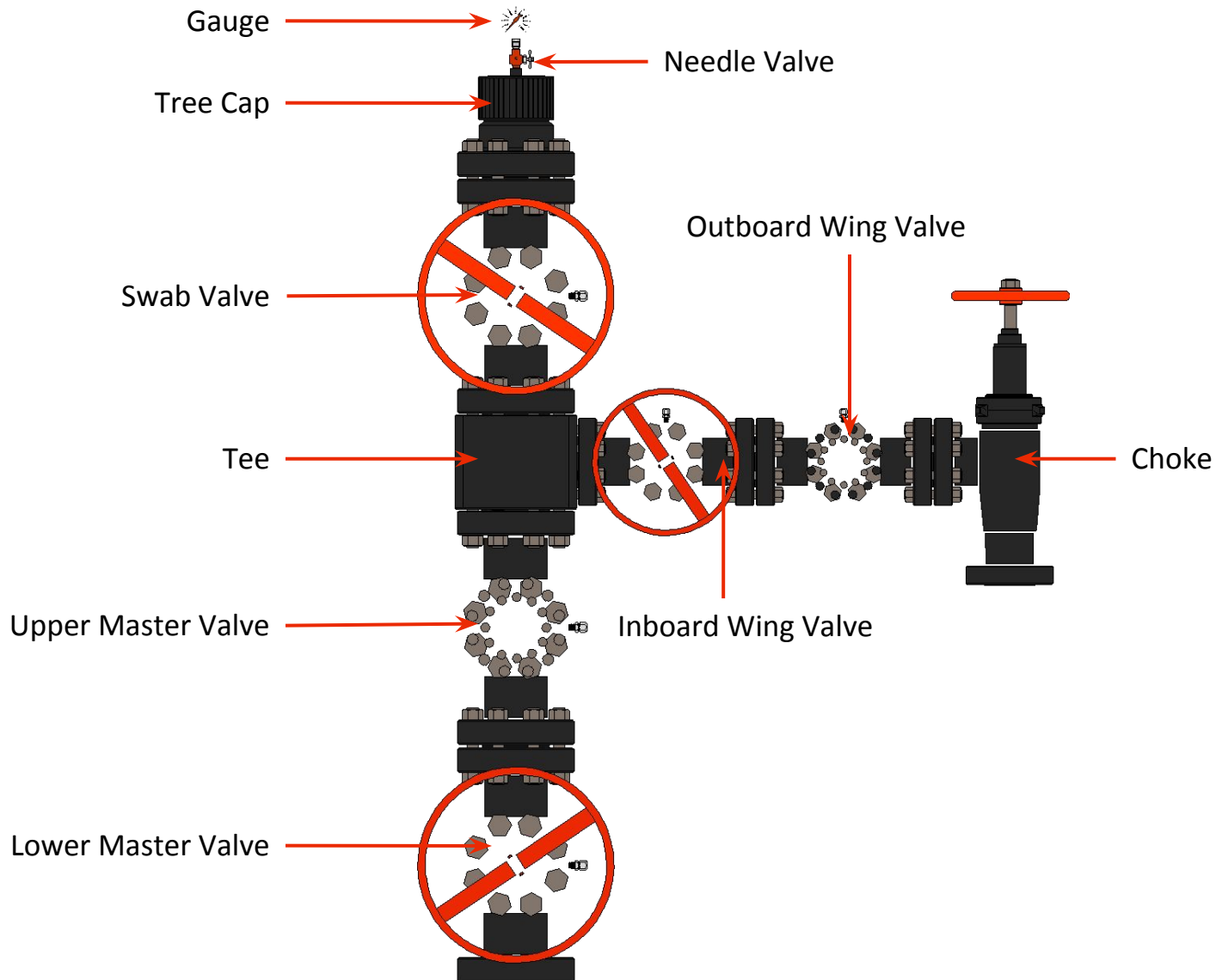



Production Gate Valves

Production Gate Valves

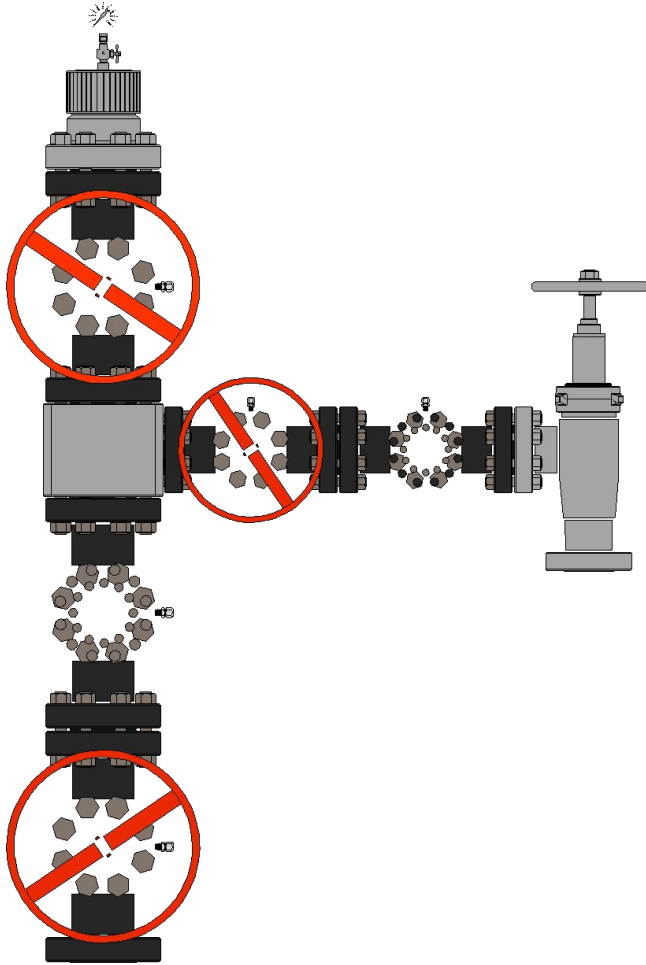

Gate valves are on/off control devices used during drilling, completion and production of oil and gas wells. They are designed to be operated in either the fully open or fully closed position. Gate valves are not chokes and should never be used for throttling.

- Gate valves are positioned primarily in two places on conventional wellhead assemblies; in the wing position of casing heads, casing spools, or tubing spools; or in a Christmas tree assembly
- Generally speaking, gate valves that are installed in the wing position of the lower sections of well-head assemblies, are called annulus valves
- The valves that are installed on the upper sections of wellhead assemblies, are called Christmas tree or production gate valves.
- These valves can be either manually operated or mechanically actuated

Production Gate Valves

Guardian G5 Gate Valves

The Guardian G5 gate valve meets API 6A PR-2 performance tests for PSL (1 & 2) and for temperature classes P-U (-20°F to 250°F) and is available forged or cast. The cast body is the standard offering. The G5 gate valve is an economical choice and is ideally suited for low to medium pressure requirements, is commonly used in production Christmas trees and is designed to be durable and easy to operate.

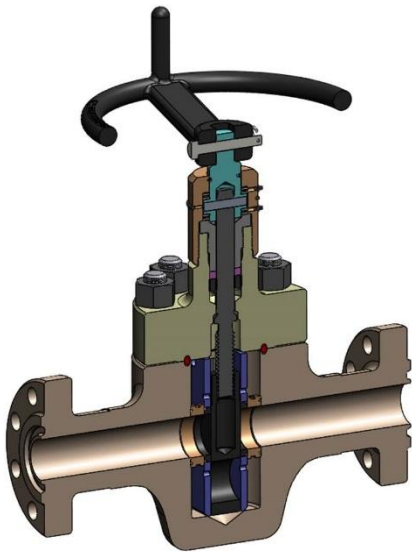

- The Guardian G5 has a floating gate and seat for bi-directional sealing
- Meets API 6A PR2 performance tests for PSL 1 & 2 and temperature classes P-U
- Is available with either a forged or cast body
- Utilizes high performance non-elastomeric stem packing
- Has a metal to metal bonnet seal
- Incorporates a back seat stem design with shear pin protection
- Utilizes a Belleville spring and Teflon insert on the seat for low pressure sealing
- Is available in manual or actuated air/hydraulic configurations
- Is available with flanged or threaded end connections

Type	Sizes	WP	PSL Levels	Material Classes
G5	2-1/16" thru 4-1/16"	3K, 5K	PSL 1 and 2	AA, DD, EE



Production Gate Valves

Guardian G10 Gate Valves

The Guardian G10 gate valve also meets API 6A PR-2 performance tests for PSL (1 & 2) and for temperature classes P-U (-20°F to 250°F) and is available forged or cast. Again, the cast body is the standard offering. The G10 gate valve has all of the features incorporated in the G5 with the addition of a carbide hard-faced metal to metal seat to gate seal.

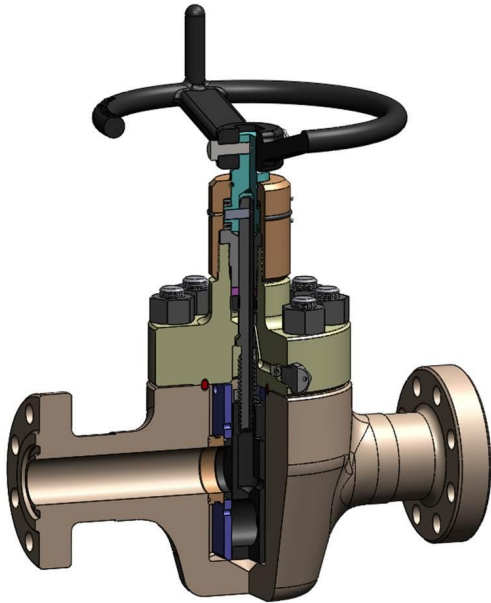

- The Guardian G10 has a floating gate and seat for bi-directional sealing
- Meets API 6A PR2 performance tests for PSL 1 & 2 and temperature classes P-U
- Is available with either a forged or cast body
- Utilizes high performance non-elastomeric stem packing
- Has a metal to metal bonnet seal
- Incorporates a back seat stem design with shear pin protection
- Utilizes a Belleville spring and a carbide hard-faced metal to metal gate to seat seal
- Is available in manual or actuated air/hydraulic configurations

Type	Sizes	WP	PSL Levels	Material Classes
G10	1-13/16" thru 4-1/16"	10K	PSL 1 and 2	AA, DD, EE





Crosses, Tees & Tree Caps

Crosses, Tees & Tree Caps

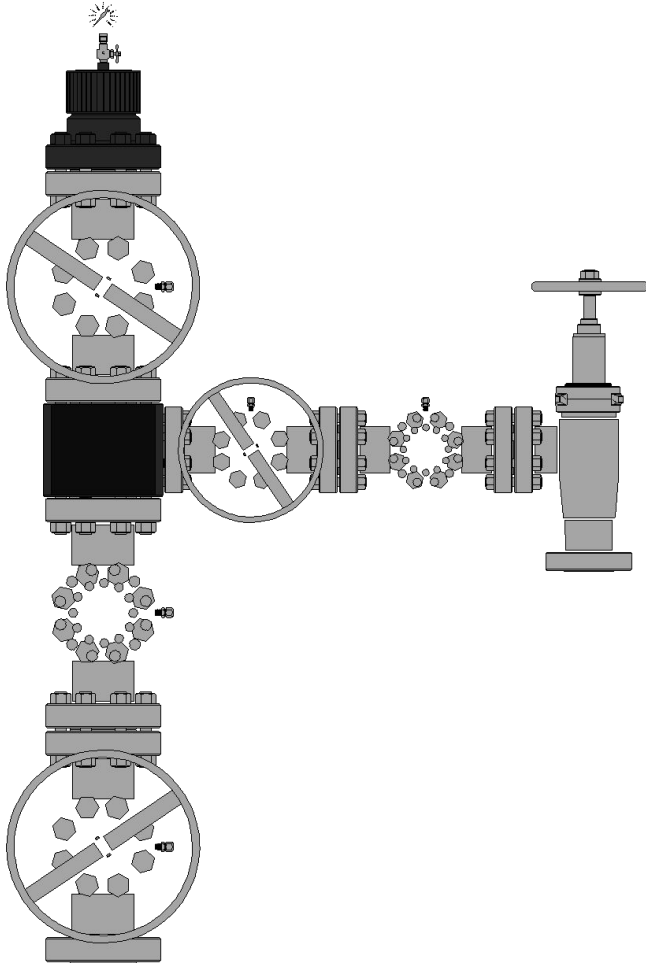

Crosses and tees are considered a very basic commodity in the wellhead industry. They are wellhead fittings that can be used to arrange a set of valves, adapters, flanges and other components into any needed configuration.

- In most instances, crosses and tees will be utilized to connect the vertical run of valves in a production or “Christmas” tree, with the horizontal run or “wing” section
- However, depending on the production needs of the well, they can also be arranged on the annulus valves of a head

Crosses, Tees & Tree Caps

Sentry Crosses

Sentry manufactures crosses in accordance with API Spec 6A. All nominal API sizes and pressure ranges are available in either studded or flanged configurations. Any special needs for tees will be created utilizing the design criteria provided in API Spec 6A.

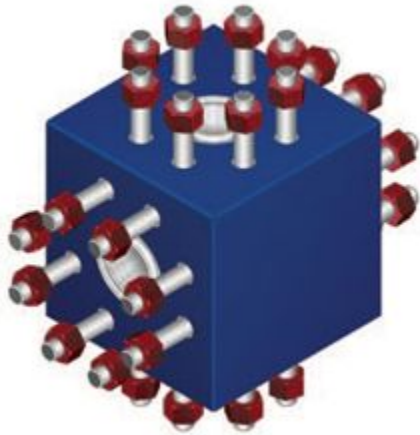

- Four separate connections, (2) vertical and (2) horizontal
- The connections can be studded, flanged or threaded
- Can be manufactured in an almost endless combination of connection types, sizes and pressure ranges
- Available in API 6A flange sizes and pressure ranges
- Special designs available on request

Type	Sizes	WP	PSL Levels	Material Classes
C-600	2-1/16" thru 7-1/16"	2K, 3K, 5K, 10K, 15K	PSL 1 thru 3	AA, DD, EE, FF



Crosses, Tees & Tree Caps

Sentry Tees

Sentry manufactures tees in accordance with API Spec 6A. All nominal API sizes and pressure ranges are available in either studded or flanged configurations. Any special needs for crosses will be created utilizing the design criteria provided in API Spec 6A.

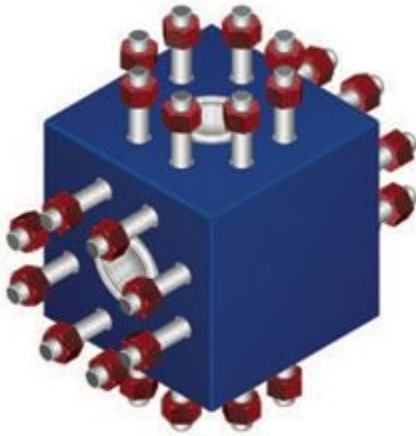

- Three separate connections, (2) vertical and (1) horizontal
- The connections can be studded, flanged or threaded
- Can be manufactured in an almost endless combination of connection types, sizes and pressure ranges
- Available in API 6A flange sizes and pressure ranges
- Special designs available on request

Type	Sizes	WP	PSL Levels	Material Classes
T-608	2-1/16" thru 7-1/16"	2K, 3K, 5K, 10K, 15K	PSL 1 thru 3	AA, DD, EE, FF



Crosses, Tees & Tree Caps

Sentry Tree Caps

Sentry manufactures tree caps utilizing design criteria in accordance with the 19th Edition API Spec 6A, Annex K. These connections offer operators a convenient way to attach well service equipment to the production tree. These tree caps are available in standard configurations and a variety of proprietary types.

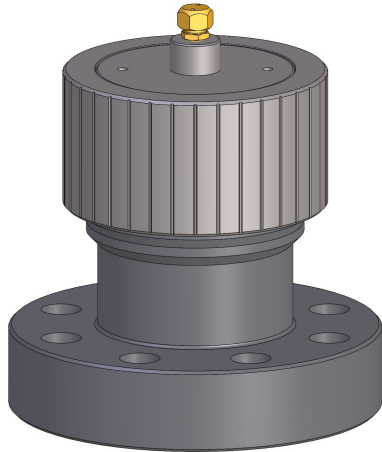

- Can provide an efficient way to gain access to the wellbore for well service equipment at the top of the tree
- Can be manufactured in an almost endless combination of connection types, sizes and pressure ranges
- Available with proprietary upper connections (Bowen, Otis, etc.)

Type	Sizes	WP	PSL Levels	Material Classes
B-15-A	2-1/16" thru 7-1/16"	2K, 3K, 5K	PSL 1 thru 3	AA, DD, EE, FF
B-11-AO	2-1/16" thru 7-1/16"	10K, 15K	PSL 1 thru 3	AA, DD, EE, FF





Production Configurations

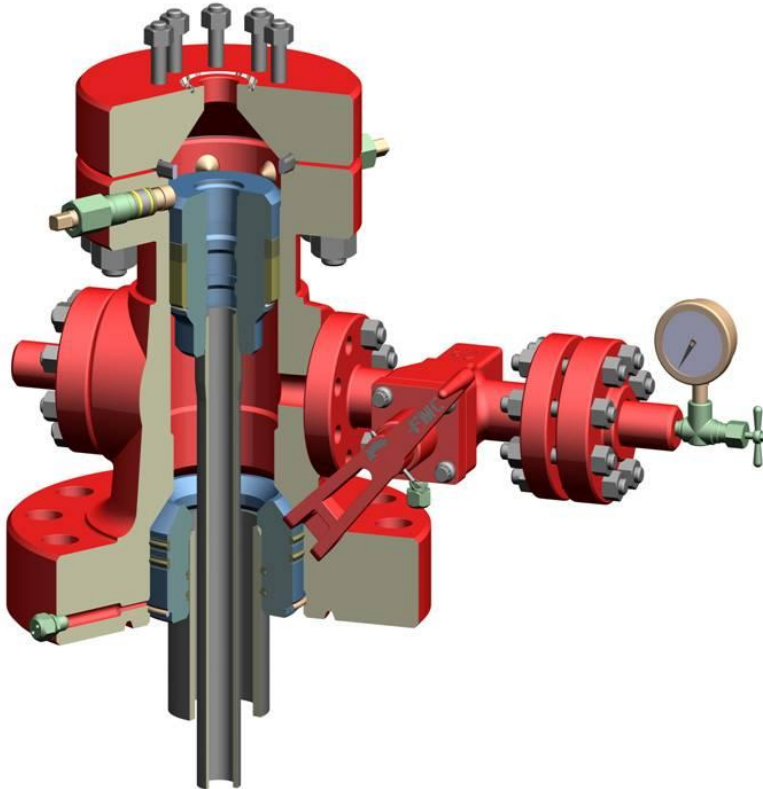

Basic Adapters

- Connects the tree to the tubing head
- No secondary seals
- TC-1A tubing hanger suspends the tubing and provides a primary weight activated compression seal that is retained by the tubing head lockdown screws

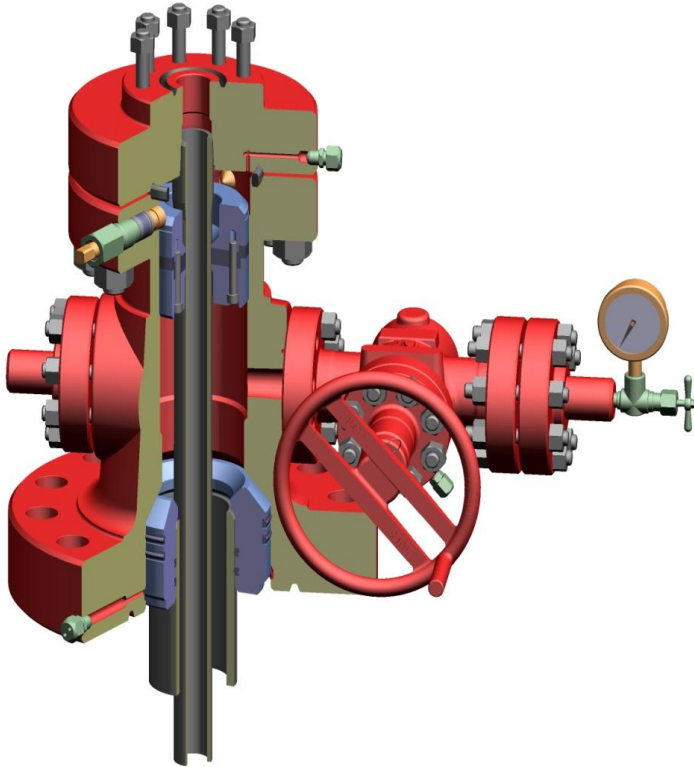

Suspension Adapters

- No secondary seals
- Suspends tubing and provides a primary seal utilizing the tubing threads machined in the bottom of the adapter
- Is normally used in conjunction with a wrap-around or stripper packoff

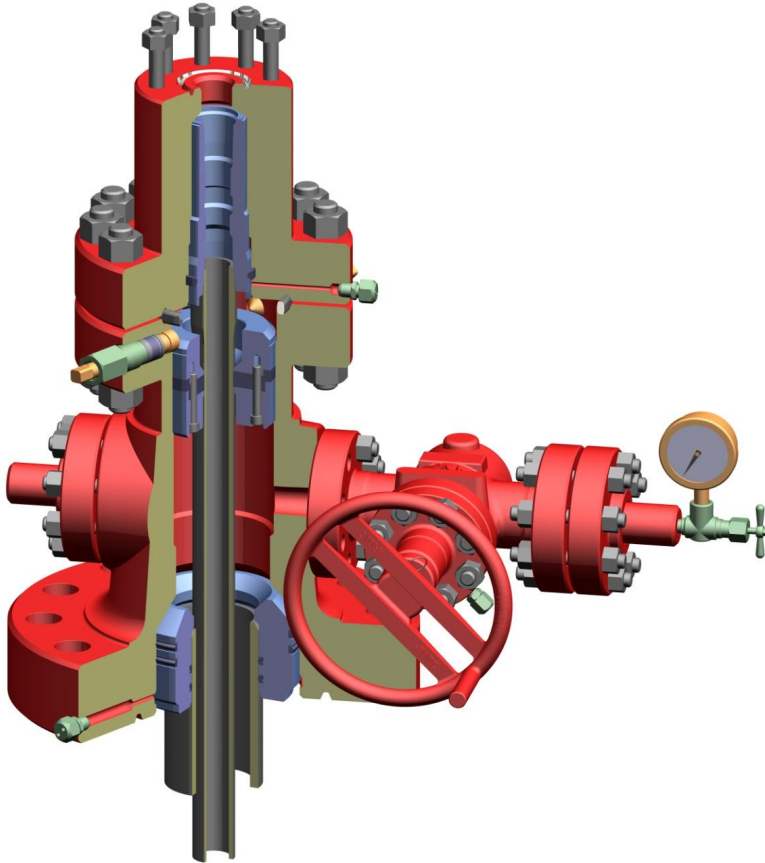

Coupling Adapters

- Has an interior acme thread to make up to the BO-2 Hanger
- Designed in various sizes
- Designed to suspend the tubing
- Has a sealing element to seal against the bottom portion of the BO-2 Coupling
- The adapter is design to convert the top tubing head adapter flange to the proper size on the bottom gate valve

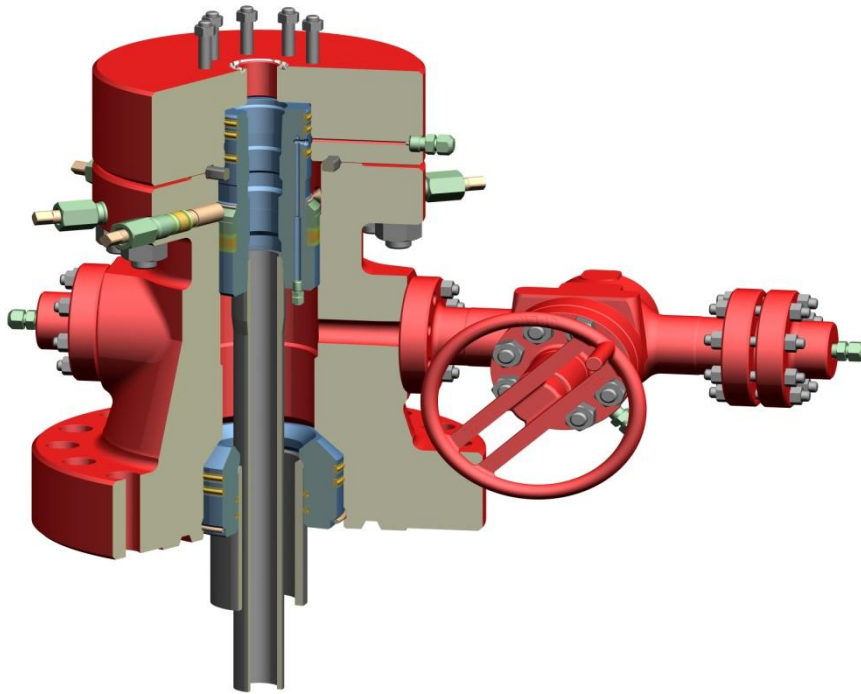

Seal Bore Adapters

- Designed in various sizes
- Does not suspend the tubing
- Depending on the sealing element of the tubing hanger, the seal can be present on the adapter rather than on the hanger
- The adapter is design to convert the top tubing head adapter flange to the proper size on the bottom gate valve

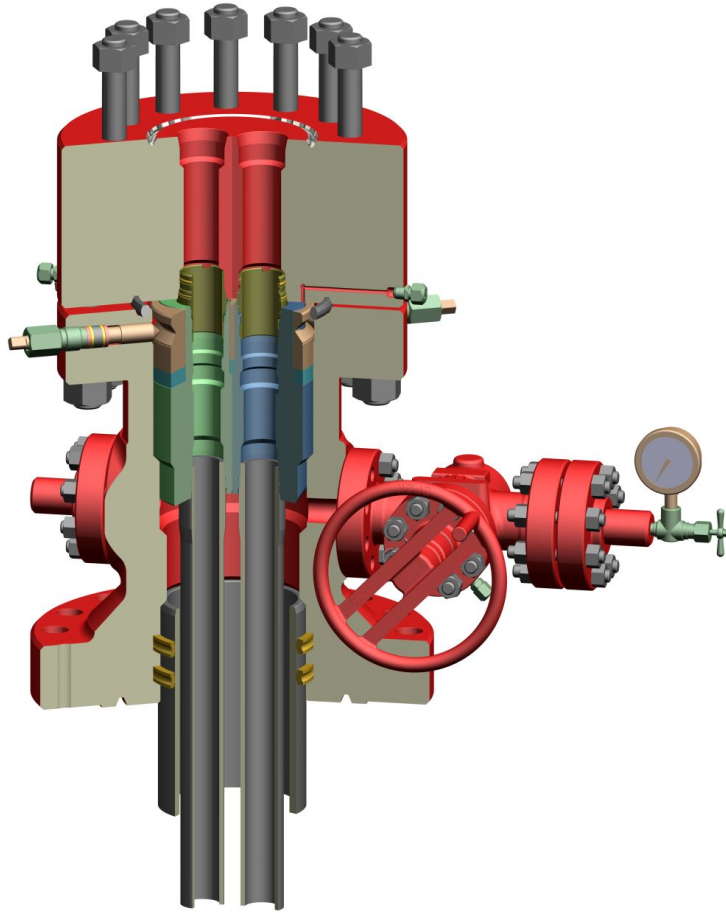

Dual Adapters

- Split Type Hanger with integral seals
- Maximum completion clearance for down hole equipment
- SSSV compatible
- LDS energized
- Tubing strings may be run and pulled independently
- BPV capability
- Seal sleeves provide secondary seals



Engineered Wellhead Systems

Engineered Wellhead Systems

Sentry TDS-1

Sentry's TDS-1 system has applications for batch drilling during field development that assists with fast BOP nipple up and can utilize offline testing. TDS-1 Thru Diverter System Cementing operations can start immediately because the T3 TDS casing head is run through the diverter on the surface casing. Operations can continue with removal of diverter and installation of the BOP adapter for drill-out of production casing.

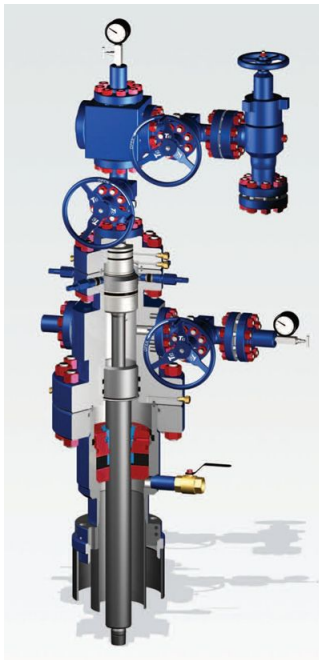

- Weldless system with pre-installed casing
- BOP adapter remains connected to the BOP allowing offline pressure testing of BOPs and fast BOP installation
- FRAC Isolation Sleeve System compatible
- Make-up of Landing Ring and TDS Casing Head running tool - together, (moves with the rig)
- Install TDS BOP adapter to the BOP stack. Adapter stays on the stack and moves with the rig
- Run using standard combination BOP test plug and wear bushing running and retrieval tool
- No third-party rental tools required

Type	Casing Size	Top Flange Size	System WP	PSL Levels	Material Classes
TDS-1	8-5/8" and 9-5/8"	11"	2K, 3K, 5K	PSL 1 thru 3	AA, DD, EE



Engineered Wellhead Systems

Sentry TDS-2

Sentry's TDS-2 system also has applications for batch drilling during field development that assists with fat BOP nipple up and can utilize offline testing. TDS-2 Thru Diverter System Casing head and diverter are one assembly, with emergency equipment design, similar to the UTB (Unitized Thru-Bore) wellhead system.

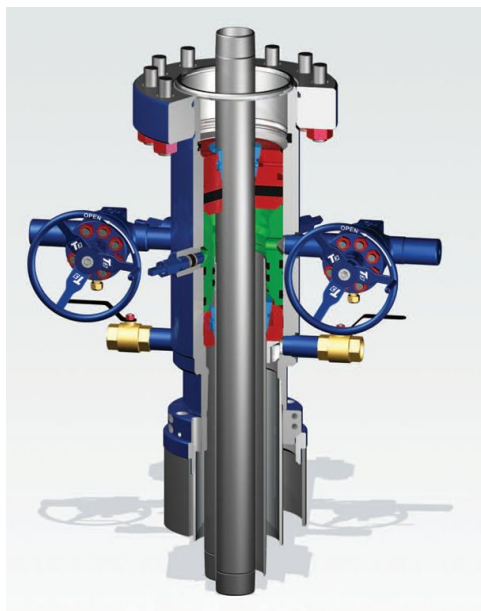

- Many of the same features as the TDS-1 weldless system with pre-installed casing
- BOP adapter remains connected to the BOP allowing offline pressure testing of BOPs and fast BOP installation
- DDV porting. Adaptable to Single and Multi-string Completions
- Incorporates casing mandrel hangers and pack-offs to further cut unproductive rig time
- Utilizes standard C-22 or C-29 emergency equipment along with the pack-off/support bushing
- No third-party rental tools required

Type	Casing Size	Top Flange Size	System WP	PSL Levels	Material Classes
TDS-2	8-5/8" and 9-5/8"	11"	2K, 3K, 5K	PSL 1 thru 3	AA, DD, EE



Engineered Wellhead Systems

Sentry UTB

Sentry's UTB system (Unitized Thru-Bore) is designed for ongoing field development at higher pressures. The Sentry UTB system utilizes mandrel hangers and pack-offs and can be run independently or together in a single trip, if needed. These hangers and pack-offs can be quickly tested after landing. Additionally, the UTB system incorporates standard off the shelf contingency casing hangers in the event that casing becomes stuck prior to reaching TD.

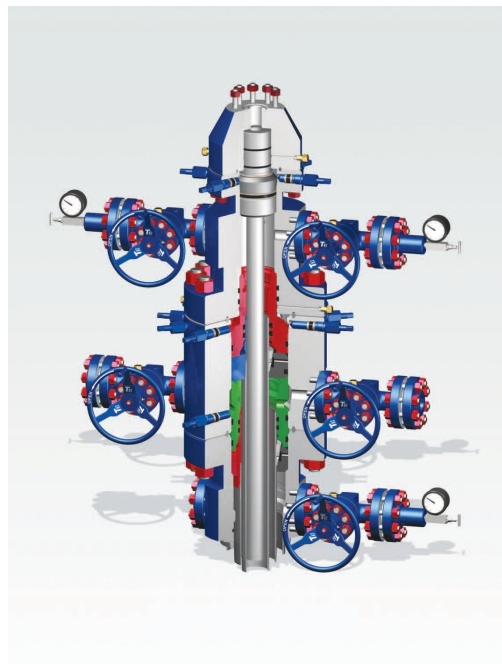

- The UTB is a through bore system, which allows the drilling rig to drill continuously, without removing the BOP until the drilling portion of the well is completed
- Mandrel hangers reduce the time required for landing casing and cementing
- Mandrel hanger pack-offs isolate the annuluses and allow for quick hydraulic testing of the annular seals after installation
- Integrates the use of standard tubing heads, tubing hangers and tubing head adapters
- Uses standardized running tools, bowl protectors and test plugs

Type	Casing Size	Flange Size	System WP	PSL Levels	Material Classes
UTB	8-5/8" thru 13-3/8"	11" and 13-5/8	3K, 5K, 10K	PSL 1 thru 3	AA, DD, EE



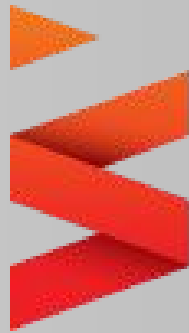

Services



Field Services

Wellhead Installation Support

Sentry's skilled technicians provide total aftermarket support in the field or the shop 24 hours a day, 365 days a year. This includes the utilization of written procedures for wellhead equipment installation, testing, field repairs and the performing of scheduled routine maintenance. They are also available for a variety of special jobs including de-completions, re-completions, trim changes and the installation of safety equipment. These services are backed by the technical support of Sentry's experts in quality control and product engineering.



- Equipment Installation and Testing
- Mechanical Integrity Testing, (MIT) for annulus and casing
- Pressure Balanced Manually Operated, (PBMO) Back Pressure Valve, (BPV) Lubricator operation and rental
- Hydraulic Back Pressure Valve, (BPV) Lubricator operation and rental
- Nitrogen gas testing for SOW casing heads
- Valve Removal , (VR) plug lubricator operation and rental
- Production valve greasing
- On-site production valve repair
- Wellsite wellhead equipment identification
- Hydraulic Bolt Torqueing services
- Mechanical casing cutting services

Field Services

FRAC Operations Support

Sentry provides the full scope of FRAC operations support services with maximum reliability, safety and effectiveness. Again we provide written procedures with Sentry's expertise and professionalism allow technicians to perform the spectrum of installation, testing and maintenance. With Sentry's extensive product experience and focus on HSE performance, technicians are ideally positioned to maximize the efficiency and safety of customer FRAC operations.



- FRAC tree and FRAC manifold rental
- FRAC tree and FRAC manifold installation
- Crane Truck rental, 30,000 Lbs. lifting capacity
- Hydrostatic testing of FRAC trees and manifolds to 15,000 PSI
- Hydraulic Bolt Torqueing services
- FRAC Valve greasing services to 15,000 PSI
- Mechanical Integrity Testing, (MIT) of the wellhead and production casing
- FRAC equipment overhaul and repair

Field Services

Wellhead Inspection Support

Sentry provides an assessment of the “Fitness-for-Service” of the wellhead equipment through a series of visual inspection and general conditioning services. Utilizing the written checklists, a “Certification of No Leaks” can be issued after a basic inspection and general conditioning of the equipment has been completed and recorded by qualified Sentry field service technicians.



- Visual inspection for the general condition of the wellhead system
- Manufacturer of the wellhead equipment
- Identification of the requested wellhead components
- Photographic record and schematic of the wellhead system
- Establish age and service life of the equipment
- Recording of current casing annulus and production wellbore pressures
- Greasing of annulus valves
- A Well Inspection Data Sheet, (WIDS) is placed in the well file



Field Services

Wellhead Integrity Support

Sentry provides a “Certification of Wellhead Integrity” after experienced Sentry Field Service Technicians complete a full suite of assessments. This includes all written procedures for the placement of required mechanical barriers so that they can perform the necessary functioning and testing procedures for all of the wellhead equipment on the customers site. Secondly this service includes full equipment identification and the recording of any readable part numbers that can assist in planning for any well work-over needs in the future. Finally a field area, as well as a location map is created, if so requested.



- Inspection of the wellhead system for corrosion/coating damage
- Inspection of the wellhead system for mechanical damage
- Photographic record and schematic of the wellhead system
- Establish the age and service life of the equipment
- Pressure checks and placement of required mechanical safety barriers
- Inspection of the flange bolting for any needed replacement
- Pressure integrity tests on all flanges, primary and secondary seals
- Re-energizing all wellhead seals as needed
- Re-applying lock-down screw and gland nut torque as needed
- Replacement of any needed fittings, packing, hand wheels, shear pins or bearings
- Full greasing of all valve bodies and stem bearings on the annulus outlets and production tree
- Provides a map for both the field area and the well location, (If requested)





Base Services

Base Services

Equipment Redress

Sentry's operational bases offer an equipment redress service. They restore equipment to standard service levels specified by the customer. Sentry redress services can include disassembly, cleaning, inspection, soft seal replacement, assembly, testing and painting. All of these processes have written procedures to insure that all repairs are carried out according to customer specification.



- Cleaning and inspection of equipment
- Customer approval required for parts replacement
- Photographic record of the equipment is kept
- Correction of any leaks
- Full pressure testing of the equipment is completed
- All redress processes are documented and stored
- Valve flushing and greasing is completed
- Painting or coating to customer specification is completed

Base Services

Equipment Repair

Additionally Sentry's operational bases offer a full range of equipment repair services. Primarily, Sentry's repair services can include disassembly, cleaning, inspection, soft seal and major component replacement. Secondly, repairs can also include welding, heat treating and machining. Finally the equipment is assembled tested and painted. All of these processes have written procedures to insure that all work is completed consistently and according to API Specification 6AR RL-2.



- Repairs are above the level of redress
- Photographic record of the equipment is kept
- Complete dis-assembly, cleaning and inspection of all components is completed
- All parts that do not pass inspection are replaced
- Equipment can be weld repaired, heat treated and re-machined as required
- All repair processes are in accordance to API 6A RL-2
- Pressure testing of the equipment
- Valve greasing
- Painting or coating to customer specification is completed

Base Services

Storage & Warehousing

Sentry's has operational bases that are strategically located to service the needs of our customers. In order to meet all demands, we warehouse API 6A Wellhead and FRAC equipment assemblies along with a full complement of spare parts. In order to properly manage our customer's equipment backlog, we utilize SYTELINE™ 9.0 MRP Software. In addition to the core application we also utilize the SYTELINE™ Service module to facilitate the storage of Service records and Service and Asset tracking.

In order to help our customers reduce the total cost of ownership we offer basic storage services for customers' equipment. This can include physical tracking services and inventory reporting. The "C/P" is kept in secured holding areas with Sentry sharing financial accountability for lost or missing equipment.



- Warehouses API 6A Wellhead and FRAC equipment
- Maintains a full complement of spare parts
- Has on site hydrostatic and gas testing capability to 15K
- Utilizes full sized OSHA approve paint cells
- Provides inspection for N.O.R.M.
- Provides for hazardous waste disposal
- Uses chlorate free paints and solvents
- Warehouse facilities have 10-Ton cranes and multiple forklifts
- Uses SYTELINE™ 9.0 MRP Software
- Stores customers' property, (C/P) on-site



Field Service Training

Field Service Training

Service Technician School (STS)

Sentry provides the knowledge and skills that field service technicians need to safely and effectively do their job. This ongoing process takes experience, commitment and focused planning. At Service Training School, (STS) we provide in-depth training and learning opportunities for all field service personnel and encourage each technician to access as much training as possible. It is our belief that service technicians build competency and confidence through extensive training. Each individual will receive a minimum of 120 days of classroom and mentored field training before being released to perform field work.



Job Planning

Sentry technicians focus on health, safety and environment (HSE) as an integral part of job planning. Whether it is the organization of their toolbox or the completion of a job hazard analysis (JHA), Sentry field service technicians are required to follow step-by-step check lists and/or operating procedures, before each project to insure the technician is situationally aware, safe and ready for precise execution of the job at hand.

Expert Training

It is incumbent on management to insure our field service technicians are technically competent before they are tactically deployed to the field. In addition Sentry's safety training courses prepare technicians to meet Sentry and OSHA HSE standards to comply with customers' safety policies and operating procedures. Sentry's state of the art training support materials include animated running procedures, 3D interactive presentations, on-site field demonstrations and online training.

Field Service Training

HSE Training Courses

It is our intent to provide the oil & gas industry with a reputation of exceptional service and continuing improvement through education. To that end we offer the following HSE training courses.



- Sentry and OSHA HSE Standards
- Fire Prevention
- Personal Protective Equipment
- Defensive Driving
- Off-road Navigation and Recovery
- USDOT Drug Screening
- Job safety Environment Analysis (JSEA)
- Step Back 5X5 hazardous communications
- Ergonomic Awareness
- CPR/First Aid
- Energy Isolation – Lock-out/Tag-out
- Petroleum Education Council (PEC) Safe Land
- Confined Space Entry
- Forklift Operations
- Lifting & Rigging
- H2S/CO2 Respiratory awareness and training
- Online CBT's (Computer Based Training)

